

# BARGE TRAIN FOR CARGO TRANSPORTATION IN NW-1: A NEW CONCEPT IN INDIAN INLAND SHIPPING

Gautham Krishnan C.G,

BTech- NAVAL ARCHITECTURE & SHIPBUILDING

Dept. of Ship Technology, Cochin University of Science & Technology

GAUTHI.SHIPTECH36@GMAIL.COM

**Abstract**— With an ever-increasing pace in urbanization & trade dynamics, cities & towns are prone to traffic-crunches & shooting pollution levels. It is a good time to switch to the inland waterways as India possesses an enriching source of water resources being surrounded by seas in three sides with inlets to various rivers, lakes & inland waters. This paper brings out the development of barge trains, that can transport cargo to industries & floating markets, and are designed to ensure economic, efficient, reliable, less emissive & hassle-free transportation

**Keywords**— Inland Waterways, Naval Architecture, Stability, Metacentric Height, Resistance, Froude's number

## INTRODUCTION

Water transport has forever been a reliable and economical mode of transporting goods and people for civilizations across the world. Inland Water Transport includes natural modes as navigable rivers, lakes and artificial modes such as man-made canals. India has an extensive network of inland waterways ranging from rivers to creeks. Freight transportation by waterways is highly under-utilised in India compared to other large countries and geographic areas like the Americas, [China](#) and the [European Union](#). Just to quote figures of comparison: -

\*In Europe, more than 37 000 kms of waterways connect hundreds of cities and industrial regions. Inland waterway transport is the perfect mode for all kind of goods. Success stories from all over Europe prove the advantages of transporting goods on Europe's integrated network of rivers and canals

\*The percentage of freight moved by India is merely 0.1% as against 21% for USA

These figures quote the under-utilisation of Inland Water transport in India and the problem is not in terms of the navigable length which comes to almost 14500 km of which over 9500 km in the form of rivers and canals are navigable. Water-borne tourism is popular in many parts of India already; it is only cargo transportation that has to pick up steadily.

The Indian Inland waterways constitute of 5 National Waterways: -

1. **National Waterway-1:** - The Ganga – Bhagirathi – Hooghly river system between Haldia & Allahabad (1620 kms) was declared as National Waterway 1(NW-1) during October 1986
2. **National Waterway-2:** - The river Brahmaputra having a length of 891 km between Bangladesh border to Sadiya in Assam was declared as National Waterway 2 (NW-2) on 1st September, 1988

3. **National Waterway 3:** - This Waterway based in Kerala constitute the West Coast canal from Kollam to Kottapuram, the Udyogamandal and Champakkara canals
4. **National Waterway-4:** - This waterway declared as NW-4 runs from Kakinada to Pondicherry.
5. **National Waterway-5:** - It is slated to run from Paradip to Haldia
6. The Barak River in Assam is touted to be National Waterway-6

In addition to this are state developed riverine systems, canals & backwaters.

## II. BARGES

A barge is a flat-bottomed [vessel](#), built mainly for [river](#) and [canal](#) transport of cargo. Some barges are not self-propelled and need to be towed or pushed by [towboats](#). Barges are used today for low-value bulk items, as the cost of hauling goods by barge is very low. These were the predominant and most effective means of Inland Cargo Transport in under-developed regions of the World before the advent of the highways and the railways that came with industrial development.. On the Mississippi riverine system today, including that of other sheltered waterways, industrial barge trafficking in bulk raw materials such as coal, coke, timber, iron ore and other minerals is extremely common. In the developed world use of huge **cargo barges** that connect in groups and trains-of-barges in ways that allow cargo volumes and weights which if used effectively can revolutionise the transportation sector.

## III. ADVANTAGE INLAND

### Cheaper capital cost

The extensive length of Indian waterways is a gift of nature, much like nature having already done the initial engineering work for 5,700 km of waterways. Therefore, there is potential for cheaper capital costs. the government estimates that capital cost of developing inland waterways is about 5-10% of the cost of developing an equivalent 4-lane expressway or railway.

### Cheaper maintenance cost

Waterways are generally cheaper to maintain except for those subject to heavy siltation which requires large scale maintenance dredging. Again based on government figures, maintenance costs are potentially of the order of 20% of that of road.

### Greater fuel efficiency

The same studies show that inland waterways transport (IWT) also has the potential to be very fuel-efficient. it is estimated that one litre of fuel can move 24 ton-km of freight by road, 85 ton-km by rail and 105 ton-km by inland water transport. IWT has the potential to be a very cost-efficient transport mode. It is estimated that every shift of one billion ton-km to inland waterways will reduce transport fuel costs by \$5 million and overall transport costs by \$9 million. It can be best used to transport heavy loads and oversized cargo.

### Carrying capacity

Inland vessels offer an enormous carrying capacity per transport unit. one motorized cargo vessel with a load of 2,000 tons carries as much cargo as 50 railway cars at 40 tons each or 80 trucks at 25 tons each. combined with comparably low transport costs, inland vessels show an excellent cost-benefit-ratio

### Safety

Inland navigation has an exemplary safety record. there is a very low probability of accidents, and should an accident happen, the costs of that accident are low in economic and human terms. barges will lead the way for safe transport, especially for dangerous cargoes, as they come with extremely high standards of inspection, training and licensing. the presence of a regulator such as a classification society gives an extra niche to safety.

#### **IV. BARGE-TRAIN CONCEPT**

The barge train concept consists of a group or fleet of barges interconnected together by couplings and towed by a couple of tugs in the popular push-pull method so that the system looks similar to a freight train and can manoeuvre well even in twisted and rough waterways, enabling extensive cargo transfer. Individual barges have self-sustaining buoyancy.

The concept of Marine trains is rare but not unheard of. Similar trains are operational in the Rhine and in parts of US. Current R&D work in this area focuses on designing very-large marine trains called sea snakes for trans-ocean cargo transportation.

##### **4.1 NEED OF BARGE-TRAINS IN INDIA**

In the context of Inland Water Transport, barge trains are an ideal choice or could be labelled as the next-gen cargo carriers, for their efficiency, versatility, reliability, ability to carry & handle cargo of different types at the same time & low risk of loss of cargo as they are stored in watertight barge-bogies so that they can withstand sinking. They also result in fewer emissions, are eco-friendly, can escape traffic and more fuel savings, i.e. reduced fuel bills. The barges could be unloaded safely at the location by use of derricks or cranes and the cargo will be sealed by a watertight hatch. Also with increasing congestion in Roadways and increased railway freight rates, Inland Waterways can be utilised really well, and particularly in areas where large amount of cargo can be transferred feasibly, subject to the route and economic constraints, Barge Trains can create wonders in the transportation sector.

#### **V. NAVAL ARCHITECTURAL PART**

Since this is a concept design, or the first of this kind and there are no parent ships in Indian Inland Waters of this kind the detailed design is not dealt with. The initial design features are decided based on operating conditions, owner's requirements, and economics.

##### **5.1 CONCEPT DESIGN**

The barge train consists of a series of barges three-to-five in number, their hulls designed to offer as low a resistance as possible, & such that they can handle different types of cargo at one time say coal, grain, fruits at the same time within the constraints posed by freeboard, stability etc.

##### **ROUTE SELECTION & SUMMARY:**

The Ganga – Bhagirathi – Hooghly river system between Haldia & Allahabad is chosen. IWAI (Inland water Authority of India) is carrying out various developmental works on the waterway for improvement of its navigability as laid down in the IWAI Act, 1985 (82 of 1985). NW-1 comprises the following stretches:

**Stretch I:** - Haldia to Farakka- 560 km

**Stretch II:** - Farakka to Patna- 460 km

**Stretch III:** - Patna to Allahabad- 600 km

**Total length of waterway:** 1620 km

The waterway is being used by tourism vessels, Over Dimensional Cargo (ODC) Carriers, IWAI vessels etc. Approximately 10 Thermal/Super Thermal Power Stations including that of NTPC's are located in the region. The power plant of NTPC requires Coal for Operation and the required amount is estimated to be as much as 3 million tons per year. The power plant situated in the vicinity of Farakka relies mainly on coal imports from Australia and many other ways, which are recessive. This implies the Haldia-Farakka stretch of NW-1 as the region of operation, where the Least Available Depth (LAD) [which is a major factor in the design of the vessel] is 2.5-3.0 m.



**FIG-1: LOCK GATE ON THE FARAKKA**

**Route:** Haldia-Farakka (NW-I)

**Radius of Action:** 560 km

**Service Speed:** 9 Knots

### **5.2 PUSH-PULL MECHANISM**

The barges are to be towed by tugs in the push-pull method i.e. one tug is set to pull the barge-train, the other will act behind & push the barge-train the dual-action can improve efficiency of the system and impart desired speed. This also reduces effort in steering; fuel consumption too could be reduced to the order of 15-20% or more. The system is to be streamlined as much as possible to reduce drag or resistance.

### **5.3 BARGE DIMENSION FIXING**

<b>ROUTE CONSTRAINTS</b>	
Maximum Draft: -	4.00 m
Least Available depth: -	2.50-3.00 m
Air Draft (Max): -	9.00 m
Lock Gates: -	Yes at Farakka
Breadth Span: -	16.00 m

The presence of a lock gate restricts the convenient manoeuvrable length to 90 m, but the presence of the push pull mechanism and the flexibility of the Barge train will allow a total length of approximately 150 m, because it's easily manoeuvrable.

**Maximum Barge Dimensions:-**

Length: 22 m

Breadth: 12 m

Depth: - 4 m

Draught: 2.5 m

The Barges in the middle are practically rectangular in nature, The Barges at the either ends will be designed with swim-ends, for hydrodynamic purposes, and will be coupled to the towboats. Block Coefficient: 0.9, considering all the barges together as a single entity.

Max No: of Barges: 4 (With a check on restrictions in manoeuvrability)

Total Volume displaced: 1585 t (approximately)

*Using Bari & Chowdury's Equation for Computing Steel Mass: -*

Steel Weight =  $0.0011 * (LOA)^{a1} * (B)^{a2}$  The Steel Mass Per Barge is 45.71 Ton, based on the Steel mass calculation formulae, the total steel weight comes to 183T, for the 4 barges plus this the total outfit weight and crew cum stores comes to 50 T, thus the steel weight may come to close to 233 T.

Payload/ (Cargo Capacity): - 1350 T

Note: The payload of only the barges are considered here as the tugs are to direct the barge train.

Joining Mechanism: - Use of a coupler and seal arrangement which is hydraulic, this will be rigid and can be used to detach manually on unloading.

**MAXIMUM TUG DIMENSIONS**

Length:	18 m
Breadth:	4.0 m (max)
Depth:	4.0 m (max)
Maximum Speed:	9 knots

Propulsor: - Thruster Propeller, as this will aid in manoeuvring but no ducts are used, as the presence of fishing grounds pose a risk of the nets getting entangled in it.

The Breadth to draught ratio of 6.4 ensures good intact stability. The Barges will be fitted with a bulwark as a practise for most Inland Vessels, and to counter the highest waves in the region.

**Preliminary Stability Calculations: -**

The indicator of stability is the Initial Metacentric height (GM), which if positive indicates good intact stability. It is calculated from the Simpson's Formula (SNAME-1957)

$$B = \sqrt{\left(KM - T \frac{5C_{WP} - 2C_B}{6C_{WP}}\right) \frac{T}{m}}$$

$$\Rightarrow KM = B^2 \frac{m}{T} + T \frac{5C_{WP} - 2C_B}{6C_{WP}}$$

Where B and T are the breadth & draughts of the vessel,  $C_B$  is the block coefficient and  $C_{WP}$  is the waterplane area coefficient. ( $m=0.0948$ ), from which we get,  $KM= 11.025$  m and  $GM= KM-KG$ , where KG is the height of the Centre of Gravity from the Baseline (which is the keel), since the barges are rectangular their weights and that of the loaded cargo will mostly act at 0.5D from the baseline, though it will be a little higher for the end barges and the tugs due to the shape of the hull. Even if we were to safely assume that the Vertical centre of Gravity for the train as a whole is at 0.6 times the depth, considering the bulwark and coupling etc. i.e.

$KG= 2.4$  m,  **$GM= 8.625$  m**, which indicates the vessel is extremely stable

**Rough Resistance Calculations:**

Resistance is the force offered by water which opposes the forward motion of the ship. The main components of the resistance are the frictional component and the wave-making component. The Barge Train as a single unit represents as a unit similar to an ultra-slender ship, with extremely high L/B Ratios, (here approximately 10.33). The high L/B Ratio and the lower Froude's number (on account of high Length) indicates that wave making resistance is negligible which is an advantage offered by the design.

Coefficient of Frictional Resistance  $C_f = 0.075 / (\log(\text{Reynolds's number}) - 2)^2$

= 0.0016787, in addition to this there will be a component of resistance (added) due to the separation/ at the junction of the barges which is taken as 20% of the frictional Resistance, for safety thus  $C_f = 0.0020144$ , after accounting for appendage and air resistances which is taken as 5% of the above,  **$C_t = 0.002115$**

Wetted Surface Area(S): We compute the Wetted Surface Areas of the tugs through Mumford's formulae: -

$S = (1.7 LT + LBC_B) * 2 = 239.40$  square. metres

The Wetted Surface of the Barges was computed as: - (Since they will be practically rectangular and a Shape allowance of 0.98 is given considering the swum ends)

$S = 2LT + LB. = 1521$  square. metres

Total Wetted Surface Area = **1760 square. metres**

Velocity (V) =9.00 knots

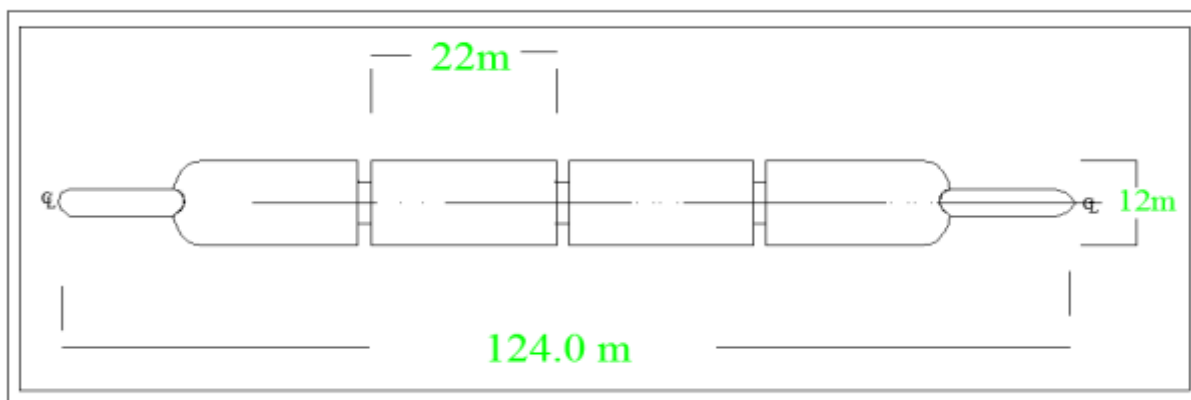

**FIG 2: TOP VIEW/ PLAN OF THE BARGE TRAIN, (SWIM ENDS FOR THE END BOGIES**

Using the relation: -  $R_{total} = C_t * 0.5 * S * V * V = 39.90 \text{ kN approx.}$

**Power required** =  $R_{total} * V = 184.72 \text{ kW}$  (These are the power requirements for normal operations against resistance, however during Manoeuvring; the power requirement will be more).

After manoeuvring requirements, Power required is **240 kW** (1.3 times the power for countering resistance). Quoting a Q.P.C of 0.5 and a shaft transmission efficiency of 0.97, (as the propellers are thrusters) The Brake Horsepower  $P_D$  comes to 495 kW. Considering this plus the electrical power required the total Installed Capacity or the Indicated power of the engine will come to 600kW. (max.) , this will be shared by the engines on the towboats. Also, Ample Ballast is to be provided when some bogies are partially loaded and others full

#### ACKNOWLEDGMENT

I thank Prof. Dileep Krishnan and Prof Dr. K Sivaprasad, who taught me the fascinating subject of Naval Architecture and encouraging innovations in this arena as I commence my career as a Naval Architectural Engineer.

#### CONCLUSION

The design parameters of the barge-train accounting the route-considerations, dimensions and the approximate power required are computed and presented based on calculations and by including design margins for assumptions where there is no apt availability for data. However, the detailed design involving structural analysis and fabrication is not presented as it's still under the research scanner for production & route studies are going on. However, owing to the advantages it vests and the returns and savings both on economic & environmental front, that includes lesser emissions, lesser operating cost, less vibration & noise (much lower than that caused by individual propelled barges), lesser number of trips. and the degree of safety offered, this concept will no doubt revolutionise the Indian transportation sector, through proper implementation.

#### REFERENCES:

- [1] "The SES Sea-Train", Bob-Scher, SNAME SD-5 Panel / International Hydrofoil Society Alion Science & Technology, 24-Febrary-2011.
- [2] "Principles of Naval Architecture- PNA", Lewis E.U, Third Edition, Volume-II, Resistance and Propulsion, SNAME, 1988
- [3] "Study On Development of Inland Water Transportation: India", Department of Ship Technology, Class-NK Report, 18- November 2012.
- [4] "Bari and Chowdury- Steel Weight Estimation", International Journal for Shipbuilding Progress
- [5] "Development of Barge Trains for Less Emissive Hassle free transportation in Indian Inland Waters", C.G Gautham Krishnan, Manu Shankar, September 2013
- [6] "The Water-Snake Concept", Student presentation at Institution of Naval Architects (INA)-Kochi Chapter Conference on Student Innovations in Naval Architecture, January 18,2015 by C.G Gautham Krishnan, Manu Shankar