

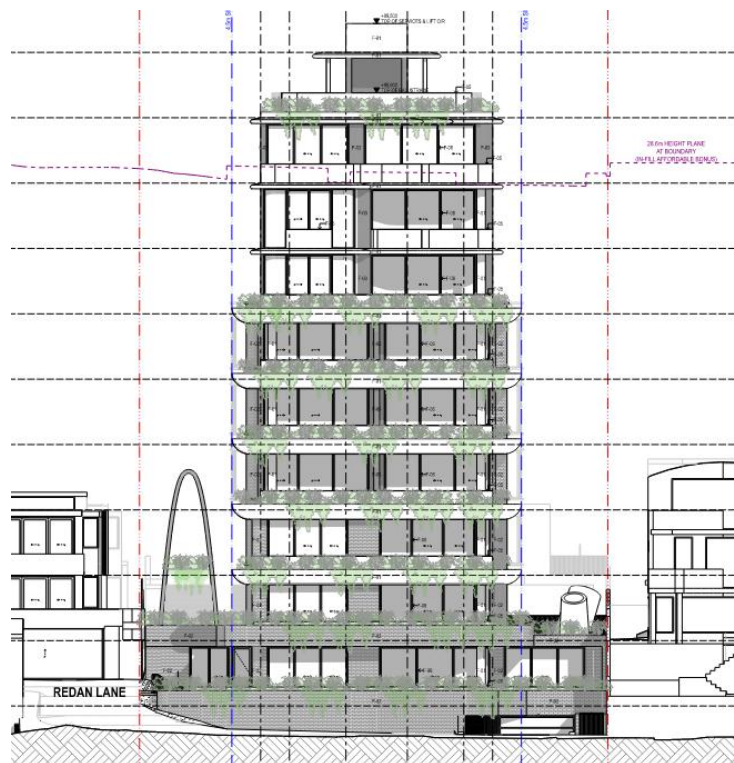

**BUILDING
INNOVATIONS
AUSTRALIA**

BCA & ACCESS 2022 A2 INDICATIVE COMPLIANCE REPORT FOR SSSA LODGEMENT

**65 Muston Street,
Mosman NSW 2088**



Prepared for: Prosker Property Pty Ltd
Project No.: PRO-10055-J3B7
Date: 20/02/2026
Status: Report Issue v1.2



Table of Contents

DOCUMENT HISTORY	3
1.0. INTRODUCTION	4
1.1. LOCATION AND DESCRIPTION	4
1.2. REPORT PURPOSE	4
1.3. BASIS OF REPORT	5
1.4. REFERENCED DOCUMENTS	5
1.5. LIMITATIONS AND EXCLUSIONS	5
1.6. LEGISLATIVE FRAMEWORK	6
1.7. TERMINOLOGY	9
2.0. BUILDING DESCRIPTION – PROPOSED DEVELOPMENT	10
2.1. BUILDING CODE OF AUSTRALIA DESCRIPTION	10
2.2. RISE IN STOREYS (RIS) (CLAUSE C2D3)	10
2.3. BUILDING CLASSIFICATIONS (PART A6).....	11
2.4. EFFECTIVE HEIGHT (SCHEDULE 1).....	11
2.5. TYPE OF CONSTRUCTION (TABLE C2D2)	12
2.6. FLOOR AREA AND VOLUME LIMITATIONS (TABLE C3D3).....	12
2.7. FIRE PROTECTION AND STRUCTURAL CAPACITY (SECTION 14, FORMALLY CL. 143)	12
2.8. FIRE BRIGADE REFERRAL (SECTIONS 25-29, FORMALLY CL. 144).....	12
3.0. BCA REQUIREMENTS	13
3.1. BCA 2022 A2 CLAUSE BY CLAUSE ASSESSMENT	14
<i>Part B1 – Structural Provisions</i>	<i>14</i>
<i>Part C2 – Fire Resistance and Stability</i>	<i>15</i>
<i>Part C3 – Compartmentation and Separation</i>	<i>18</i>
<i>Part C4 – Protection of Openings.....</i>	<i>22</i>
<i>Specification 5–Fire-Resisting Construction.....</i>	<i>26</i>
<i>Part D2 – Provision for Escape.....</i>	<i>29</i>
<i>Part D3 – Construction of Exits.....</i>	<i>36</i>
<i>Part D4 – Access for People with Disabilities.....</i>	<i>49</i>
<i>Part E1 – Fire Fighting Equipment</i>	<i>64</i>
<i>Part E2 – Smoke Hazard Management.....</i>	<i>74</i>
<i>Part E3 – Lift Installations.....</i>	<i>80</i>
<i>Part E4 – Visibility in an Emergency, Exit Signs and Warning Systems.....</i>	<i>83</i>
<i>Part F1 – Surface water management, rising damp and external waterproofing.....</i>	<i>85</i>
<i>Part F2 – Wet areas and overflow protection.....</i>	<i>86</i>
<i>Part F3 – Roof and wall cladding</i>	<i>87</i>
<i>Part F4 – Sanitary and Other Facilities</i>	<i>88</i>
<i>Part F5 – Room heights.....</i>	<i>95</i>
<i>Part F6 – Light and Ventilation</i>	<i>97</i>
<i>Part F7 – Sound Transmission and Insulation</i>	<i>99</i>
<i>Part F8 – Condensation management.....</i>	<i>102</i>
<i>Part G1 – Minor Structures and Components.....</i>	<i>104</i>
<i>Part G2 – Boilers, pressure vessels, heating appliances, fireplaces, chimneys and flues.....</i>	<i>104</i>
<i>Part G3 – Atrium construction</i>	<i>104</i>
<i>Part G4 – Construction in alpine areas</i>	<i>104</i>
<i>Part G5 – Construction in bushfire prone areas.....</i>	<i>104</i>



Part G6 – Occupiable outdoor areas..... 105
 Part G7 – Livable housing design..... 106
 Part I1 – Class 9b Buildings..... 107
4.0. CONCLUSION 109
APPENDIX A – FIRE RESISTANCE LEVELS (TYPE A CONSTRUCTION) 110
 TABLE S5C11A: TYPE A CONSTRUCTION: FRL OF LOADBEARING PARTS OF EXTERNAL WALLS 110
 TABLE S5C11B: TYPE A CONSTRUCTION: FRL OF NON-LOADBEARING PARTS OF EXTERNAL WALLS 110
 TABLE S5C11C: TYPE A CONSTRUCTION: FRL OF EXTERNAL COLUMNS NOT INCORPORATED IN AN EXTERNAL WALL..... 110
 TABLE S5C11D: TYPE A CONSTRUCTION: FRL OF COMMON WALLS AND FIRE WALLS..... 110
 TABLE S5C11E: TYPE A CONSTRUCTION: FRL OF LOADBEARING INTERNAL WALLS 111
 TABLE S5C11F: TYPE A CONSTRUCTION: FRL OF NON-LOADBEARING INTERNAL WALLS..... 111
 TABLE S5C11G: TYPE A CONSTRUCTION: FRL OF OTHER BUILDING ELEMENTS NOT COVERED BY TABLES S5C11A TO S5C11F..... 111
APPENDIX B – SCHEDULE 2: REFERENCED DOCUMENTS..... 113
 TABLE 1 SCHEDULE OF REFERENCED DOCUMENTS 113
 NSW TABLE 1 SCHEDULE OF REFERENCED DOCUMENTS 120
APPENDIX C – REFERENCED DOCUMENTATION..... 121

Document History

Date	Issue	Status	Prepared by	Assessed by	Reviewed by
11.12.2025	Draft Report v0.1	Initial document created	Jennifer Lee	Mardiros Tatian	Mardiros Tatian
13.02.2026	Draft Report v0.2	Report updated to reflect latest plans	Jennifer Lee	Mardiros Tatian	Mardiros Tatian
13.02.2026	Report Issue v1.0	Report issued to client	Jennifer Lee	Mardiros Tatian	Mardiros Tatian
19.02.2026	Report Issue v1.1	Report updated to reflect stakeholder comments	Jennifer Lee	Mardiros Tatian	Mardiros Tatian
20.02.2026	Report Issue v1.2	Report updated to reflect stakeholder comments	Jennifer Lee	Mardiros Tatian	Mardiros Tatian

Liability limited by a scheme approved under Professional Standards Legislation.

1.0. INTRODUCTION

1.1. Location and Description

This report is prepared in preparation of a State Significant Development Application (SSDA) lodgement and is for assessment purposes, it comprises a National Building Code of Australia 2022 Amendment 2 (NBCA) assessment of the proposed residential flat building as required under Section 19 of the Environmental Planning and Assessment Regulations.

The development incorporates the demolition of existing structures and construction of a new twelve (12) storey building comprising of thirteen (13) residential apartments, a gym in Lower Ground 02, swimming pool in Lower Ground 01, and associated storage and car parking spaces located in the two (2) Basement and two (2) Lower Ground levels.

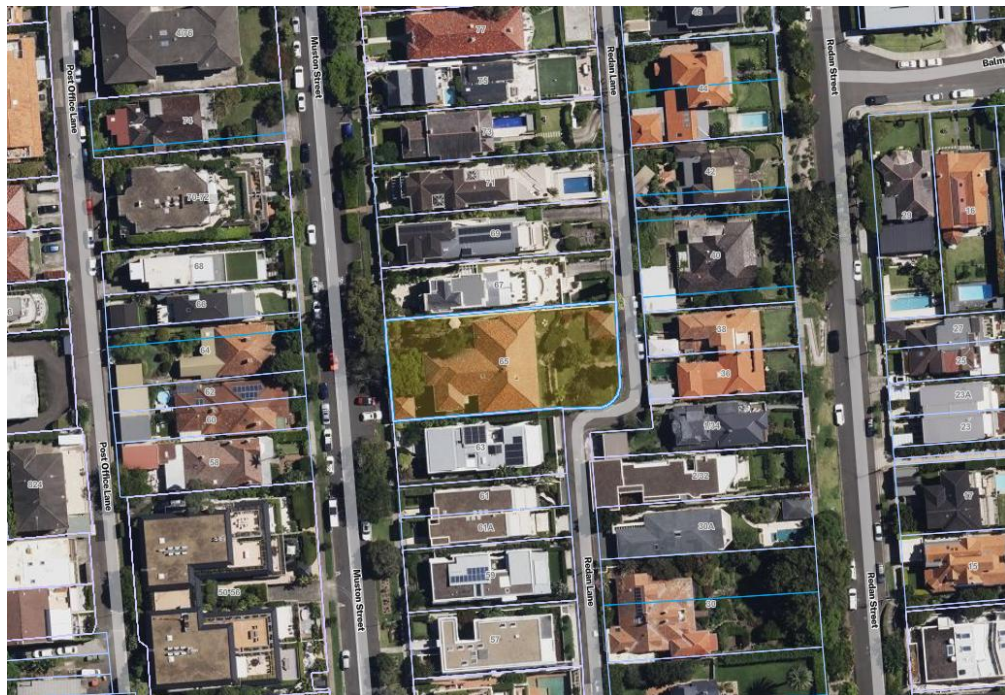

Figure 1 Site location and topography

1.2. Report Purpose

The purpose of this report is to provide an indicative compliance assessment of the SSDA design documentation for the proposal, against the current requirements of the BCA.

Demonstrating compliance with the BCA is not a prescribed head of consideration under Section 4.15 (formally Section 79C) of the Environmental Planning & Assessment Act 1979. It is noted however that the Department of Planning, Housing and Infrastructure (DPHI) has an obligation to consider whether the SSDA proposal, as lodged, is indicatively capable of complying with the BCA - without significant modification to those plans for which approval is sought.

This report will demonstrate that there will be no additional requirements, resulting from prescribed application of the BCA, for any significant design changes that would necessitate the submission of an application under Section 4.55 (formally Section 96) of the Environmental Planning and Assessment Act 1979.

As such, and to pre-empt the Certifying Authority's role under Section 19 of the Environmental Planning & Assessment (Development Certification and Fire Safety) Regulation 2021, we have undertaken a preliminary assessment of the development against the provisions of the BCA applicable to the lodged State Significant Development Application (SSDA).

1.3. Basis of Report

This report is based upon and limited to:

- An assessment of design documentation referenced in Appendix C of this report.
- The Deemed-to-Satisfy provisions of the National Building Code of Australia 2022 Amendment 2 including the NSW variations where applicable.

1.4. Referenced Documents

The following documentation was relied upon when preparing this report:

- Assessment of design documentation referenced in Appendix C of this report.
- The performance and deemed-to-satisfy provisions of the National Building Code of Australia 2022 Amendment 2 incorporating the NSW Appendices where applicable.
- Guide to the National Building Code of Australia.
- Disability (Access to Premises — Buildings) Standards 2010.
- Environmental Planning & Assessment Act 1979.
- Environmental Planning & Assessment (Development Certification and Fire Safety) Regulation 2021.

1.5. Limitations and Exclusions

The limitations and exclusions of this report are as follows:

- The plans are assessed indicatively to the extent necessary to proceed to construction certificate stage whereby assessment will be undertaken pursuant to Part 4A of the Environmental Planning and Assessment Act 1979. This means that the design has been assessed to be able to comply with the BCA (i.e. the submitted plans are consistent with the BCA but certain design details may not be specified at this stage due to the plans and specifications being at pre DA stage).
- This Report does not address issues in relation to the following:
 - a) The structural adequacy of the building including the Fire Resistance Levels (FRL's) of any building elements (unless specifically referred to).
 - b) The design, maintenance or operation electrical, mechanical, hydraulic or fire protection services.
 - c) Environmental Planning and Assessment Act and Regulations (unless specifically referred to).
 - d) Local Government Act and Regulations.
 - e) Occupational Health and Safety Act and Regulations.
 - f) WorkCover Authority requirements.
 - g) Requirements of other Regulatory Authorities including, but not limited to, Telstra, Sydney Water, Electricity Supply Authority, RTA, the Department of Planning, Housing and Infrastructure (DPHI), Council and the like.
 - h) Disability Discrimination Act (DDA) other than minimum requirements under the Disability (Access to Premises — Buildings) Standards 2010. DDA is a Case by Case Assessment, this building will comply with the set items under the Premises Standards.
 - i) Construction Safety Act.
 - j) Conditions of Development Consent issued by the DPHI and relevant consent authority.



- This assessment does not incorporate the detailed requirements of the Australian Standards.
- Building Innovations Australia Pty Ltd cannot guarantee acceptance of this report by the Local Council, NSW Fire Brigades, the Department of Planning, Housing and Infrastructure (DPHI) or other approval authorities.
- Without written permission from Building Innovations Australia Pty Ltd, no part of this document may be reproduced in any form or by any means. This report is based solely on client instructions, and therefore should not be used by any third party without prior knowledge of such instructions.

1.6. Legislative Framework

Section 4.15 (formally Section 79C) of the Environmental Planning and Assessment Act provides the matters of consideration that the consent authority must take into account in the determination of a development application.

Once development consent is granted, and pursuant to Section 19 of the Environmental Planning & Assessment (Development Certification and Fire Safety) Regulation 2021, a certifying authority must not issue a construction certificate for building work unless:

- (a) *the relevant building work plans and specifications include the matters required by a relevant BASIX certificate, if any, and*
- (b) *the design and construction of the building, as described in the relevant building work plans and specifications and in other information given to the certifier under section 12, is consistent with the development consent, and*
- (c) *the building will comply with the relevant requirements of the Building Code of Australia as in force at the time the application for the construction certificate was made.*

Compliance with the National Building Code of Australia

The BCA is a performance based document whereby compliance can be achieved by satisfying the deemed to satisfy requirements or by formulating an alternative solution to address the relevant performance requirements.

As indicated above, the requirements of the Environmental Planning and Assessment Regulations requires all new building works to comply with the relevant requirements of the BCA (as in force at the time the application for the construction certificate was made).

This means that the plans and documentation submitted with the *construction certificate* (CC) application must demonstrate full compliance with the relevant provisions of the Building Code of Australia.



Section 14 Fire protection and structural capacity

If your development incorporates a Change of Use, Category 1 fire safety measures must be considered and implemented into the design as applicable:

- E1P3: A fire hydrant system*
- E1P4: An automatic fire suppression system*
- E1P6: Suitable facilities must be provided to the degree necessary in a building to co-ordinate fire brigade intervention*
- E2P1: Sleeping Accommodation, occupants must be provided with automatic warning*
- E2P2: Conditions in any evacuation route must be maintained for the period of time occupants take to evacuate*
- E3P2: One or more passenger lifts fitted as emergency lifts to serve each floor served by the lifts in a building must be installed to facilitate the activities of the fire brigade and other emergency services personnel*

Details of the above will need to be identified on the Building Fire Safety Schedule/Statement as present, if not present; these measures will need to be installed in to the building if applicable.

Referral of certain plans and specifications to New South Wales Fire Brigades

Under the Environmental Planning & Assessment (Development Certification and Fire Safety) Regulation 2021, Section 18 and Sections 25-29 have specific requirements for any Fire Engineering which identifies Category 2 fire safety provisions which form part of a building being more than 6,000m² and/or within a Fire Compartment more than 2,000m².

Category 2 means the following provisions of the Building Code of Australia, namely, C1P9, E1P3, E1P4, E1P6, E2P2 and E3P2 in Volume One of that Code

If this building has a floor area of more than 6,000m² or a performance solution is proposed within a fire compartment more than 2,000m², any Performance Solution which identifies one or more of the above performance provisions, Fire Brigade approval is required in the form of a Section 25-29 (formally Cl. 144) Approval along with a required Engineering Statement under Section 18 (formally Cl. 144A) and following the completion of the building a Section 50 (formally Cl. 152) Report from the Fire Commissioner is required, a final fire safety report for a building means a written report specifying whether or not the Fire Commissioner is satisfied that:

- (a) the building work complies with a performance solution for a Category 2 fire safety provision that was the subject of the construction certificate, and
- (b) the fire hydrants in the fire hydrant system will be accessible for use by Fire and Rescue NSW, and
- (c) the couplings in the fire hydrant system will be compatible with the fire appliances and equipment used by Fire and Rescue NSW.



Fulfilment of BASIX Commitments (Residential only)

Section 43 of the Environmental Planning & Assessment (Development Certification and Fire Safety) Regulation 2021 requires a certifying authority to monitor fulfilment of any commitments listed on the BASIX certificate, where the BASIX requires the certifying authority to monitor those commitments.

A certifying authority must not issue an occupation certificate (whether interim or final) for any building resulting from, or any building that becomes a BASIX affected building because of, BASIX affected development or BASIX optional development to which this clause applies, or for any part of such a building, unless each of the commitments whose fulfilment it is required to monitor in relation to the building or part has been fulfilled.

For the purpose of satisfying itself as to the fulfilment of any such commitment, a certifying authority may rely on the advice of any properly qualified person (i.e. Energy Efficiency Consultant).

Special Requirements for Residential Flat Developments

Section 15 (formally Cl. 143A) of the Environmental Planning & Assessment (Development Certification and Fire Safety) Regulation 2021 requires a qualified designer to provide a statement that verifies that the plans and specifications that form part of construction certificate application achieve or improve the design quality of the development having regard to the design quality principles set out in Part 2 of the State Environmental Planning Policy No. 65 – Design Quality of Residential Flat Development prior to the issue of a Construction Certificate.

Section 43 (formally Cl. 154A) of the Environmental Planning & Assessment (Development Certification and Fire Safety) Regulation 2021 requires a qualified designer to provide a statement that verifies that the residential flat development achieves the design quality of the development as shown in the plans and specifications having regard to the design quality principles set out in Part 2 of the State Environmental Planning Policy No. 65 – Design Quality of Residential Flat Development prior to the issue of an Occupation Certificate.

Disability (Access to Premises — Buildings) Standards 2010

Disability (Access to Premises — Buildings) Standards 2010 has been introduced and is applicable to this building. It is noted that unless Part D4, Clauses E3D7, E3D8, F4D5, F4D6 & F4D7 are included in the below assessment, an access consultant may need to be engaged to provide specific comments as to compliance with this standard. Note that except for slight variations, particularly for Class 1b buildings, available verification methods and adult change facilities, as this is a new building to BCA 2022 A2, compliance with the Disability (Access to Premises — Buildings) Standards 2010 would inherently comply.



1.7. Terminology

- *Building Code of Australia* - Document published on behalf of the Australian Building Codes Board. The BCA is a uniform set of technical provisions for the design and construction of buildings and other structures throughout Australia and is adopted in NSW under the provisions of the Environmental Planning & Assessment Act & Regulation.
- *Fire Resistance Level (FRL)* - means the grading periods in minutes tested in accordance with AS 1530.4-2014 for the following criteria -
 - (a) structural adequacy; and
 - (b) integrity; and
 - (c) insulation,and expressed in that order.
- *Fire Source Feature (FSF)* - the far boundary of a road adjoining the allotment; or a side or rear boundary of the allotment; or an external wall of another building on the allotment which is not a Class 10 building.
- *Open space* - means a space on the allotment, or a roof or other part of the building suitably protected from fire, open to the sky and connected directly with a public road.
- *Performance Requirements of the BCA* - A Building Solution will comply with the BCA if it satisfies the Performance Requirements. A Performance requirement states the level of performance that a Building Solution must achieve.

Compliance with the Performance Requirements can only be achieved by-

 - (a) complying with the Deemed-to-Satisfy Provisions; or
 - (b) formulating a Performance Solution which-
 - (i) complies with the Performance Requirements; or
 - (ii) is shown to be at least equivalent to the Deemed-to-Satisfy Provisions; or
 - (c) a combination of (a) and (b).
- *Sole occupancy unit* - means a room or other part of a building for occupation by one or joint owner, lessee, tenant, or other occupier to the exclusion of any other owner, lessee, tenant, or other occupier.

2.0. BUILDING DESCRIPTION – PROPOSED DEVELOPMENT

2.1. Building Code of Australia Description

For the purposes of the Building Code of Australia 2022 A2 (BCA) the proposed development may be described as follows.

2.2. Rise in Storeys (RIS) (Clause C2D3)

The overall building has a rise in storeys of ten (10)** as illustrated below;

The number of storeys contained is twelve (12)*.

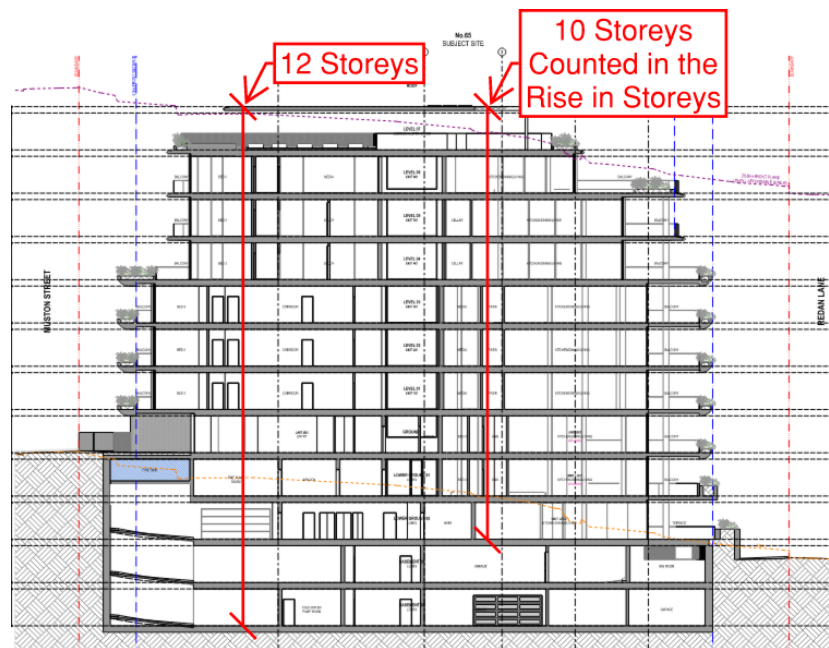

* A *storey*, as defined by the BCA, is the space within a building situated between one floor level and the next level, or if there is no floor above, the ceiling or roof above, and doesn't exclude levels under the ground floor.

**The *rise in storeys*, as determined by the BCA, is the sum of the storeys counted in the rise in storeys, as defined in Clause C4D3.

2.3. Building Classifications (Part A6)

The proposed building has been classified as follows.

BUILDING LEVELS	PLAN LEVELS	CLASSIFICATION	USE	RIS
Basement 2	Basement 02	Class 7a	Carpark	-
Basement 1	Basement 01	Class 7a	Carpark	-
Lower Ground 2	Lower Ground 02	Class 2, 7a, 9b	Residential, Carpark, Wellness Centre	1
Lower Ground 1	Lower Ground 01	Class 2, 7a, 10b	Residential, Carpark, Swimming Pool	2
Ground Floor	Ground Level	Class 2	Residential	3
First to Sixth Floor	Level 1-6	Class 2	Residential	4-10
Seventh Floor	Level 7	-	-	-
Roof	Roof	-	-	-

2.4. Effective Height (Schedule 1)

The building has an effective height (EH) of approximately **30.600m** when measured from the floor of the topmost storey which is greater than 25m but less than 50m.

*Lowest Point taken @ RL 64.000 (Approx.)

*Highest Point taken @ RL 94.600



2.5. Type of Construction (Table C2D2)

The building is required to be of **Type 'A'** Construction.

2.6. Floor Area and Volume Limitations (Table C3D3).

The building is subject to maximum floor area and volume limits under Type 'A' Construction of:

Class of Building Part	Floor Area & Volume		Outcome
	Max Permitted (Table C2.2)	Max. Proposed	
▪ Class 7a	5,000 m ²	< 5,000 m ²	Complies
	30,000 m ³	< 30,000 m ³	
▪ Class 9b	8,000 m ²	< 8,000 m ²	Complies
	48,000 m ³	< 48,000 m ³	

**Class 7a is exempt from Table C3D3 Floor Area restrictions if Carpark is proposed to be Sprinkler Protected pursuant to Clause E1D4.*

The Class 2 portions of the building are not subject to any floor area and volume limitations of C3D3 of the BCA. Table S5C11a–g of Specification 5 and C4D12 of the BCA regulate compartmentalisation and separation provisions applicable to Class 2 buildings or building portions.

2.7. Fire protection and structural capacity (Section 14, formally Cl. 143)

If your development incorporates a Change of Use, Category 1 fire safety measures must be considered and implemented in to the design as applicable.

E1P3: A fire hydrant system (required)

E1P4: An automatic fire suppression system

E1P6: Suitable facilities must be provided to the degree necessary in a building to co-ordinate fire brigade intervention

E2P1: Sleeping Accommodation, occupants must be provided with automatic warning

E2P2: Conditions in any evacuation route must be maintained for the period of time occupants take to evacuate

E3P2: One or more passenger lifts fitted as emergency lifts to serve each floor served by the lifts in a building must be installed to facilitate the activities of the fire brigade and other emergency services personnel

2.8. Fire Brigade referral (Sections 25-29, formally Cl. 144)

If this building requires Fire Engineering referral would need to be forwarded to the NSW Fire Brigades under a Section 25-29 fire brigade referral.

3.0. BCA REQUIREMENTS

Noting that the level of documentation at this stage is for a State Significant Development Application (SSDA) assessment purposes, an indicative compliance assessment of the referenced documents identified in Appendix C of this report has been undertaken against the Deemed-to-Satisfy Provisions of the National Building Code of Australia 2022 Amendment 2 (BCA).

Outlined below is a summary of the Deemed-to-Satisfy Provisions of the BCA. All Deemed-to-Satisfy clauses that are applicable to the subject building have been referred to below, including a comment adjacent to each clause of the proposal's ability to satisfy each respective clause.

The abbreviations outlined below have been used in the following tables:

N / A	The Deemed-to-Satisfy clause does not apply to the subject Building.
Complies	The relevant provisions of the Deemed-to-Satisfy clause have been demonstrated by the proposed design and existing building features, notwithstanding it is at consent stage.
CRA	'Compliance Readily Achievable'. It is considered that the level of detail included in the consent-level documentation will not determine strict compliance with the individual BCA clause requirements. However, subject to noting the requirements of each clause, it is considered BCA compliance can be readily demonstrated without significant implication to the approved design. This will occur through progression of documentation to the Construction Certificate stage of the development.
FI	Further information is necessary to determine the compliance potential of the building design.
PS	Performance Solution with respect to this Deemed-to-Satisfy Provision is possible to satisfy the relevant BCA Performance Requirements.
DNC	Does Not Comply.
DTS	Deemed-To-Satisfy provisions as defined by the National Building Code of Australia 2022 A2.

3.1. BCA 2022 A2 Clause by Clause Assessment

SECTION B – STRUCTURE

Part B1 – Structural Provisions			
Clause	Description	Status	Comments
B1D1	Deemed-to-Satisfy Provisions	-	-
B1D2	Resistance to actions	CRA	The resistance of a building or structure must be greater than the most critical action effect resulting from different combinations of actions. Structural details and a design certificate will be obtained from a qualified structural engineer prior to the issue of a Construction Certificate.
B1D3	Determination of individual actions	CRA	The magnitude of individual actions must be determined in accordance with Clause B1D3 of the BCA. Structural details and a design certificate will be obtained from a qualified structural engineer prior to the issue of a Construction Certificate.
B1D4	Determination of structural resistance of materials and forms of construction	CRA	The structural resistance of materials and forms of construction must be determined in accordance with the relevant Australian Standards in accordance with Clause B1D4 of the BCA. Structural details and a design certificate will be required by a qualified structural engineer prior to the issue of a Construction Certificate.
B1D5	Structural Software	Noted	
B1D6	Construction of buildings in flood hazard areas	Noted	

SECTION C – FIRE RESISTANCE

Part C2 – Fire Resistance and Stability			
Clause	Description	Status	Comments
C2D1	Deemed-to-Satisfy Provisions	-	-
C2D2	Type of construction required	Noted	The building is to be erected in Type 'A' fire resisting construction in accordance with Specification 5 of the BCA. Refer to 'Appendix' A for the relevant fire resisting requirements. Plans to reflect required FRLs prior to the issue of a Construction Certificate.
C2D3	Calculation of rise in storeys	Noted	The building has an overall rise in storeys of ten (10). The building contains twelve (12) storeys.
C2D4	Buildings of multiple classification	Noted	The building is required to be constructed of Type 'A' fire resisting construction as the classification of the top storey is a Class 2.
C2D5	Mixed types of Construction	Noted	If a fire wall divides the building in accordance with Clause C3D8, the building portions are able to be constructed in differing levels of fire-resistance determined in accordance with Clause C2D2 and C2D4.
C2D6	Two storey Class 2, 3 or 9c buildings	N / A	
C2D7	Class 4 parts of buildings	N / A	
C2D8	Open spectator stands and indoor sports stadiums	N / A	
C2D9	Lightweight construction	CRA or PS	Lightweight construction used in a wall system must comply with Specification 6. Lightweight construction used as a fire-resisting covering of a steel column or the like, and where the covering is not in continuous contact with the column must have the voids filled to a height of not less than 1.2m above the floor and where the column is liable to be damaged must be protected by steel or other suitable material. If lightweight construction is used in the proposed development, then details demonstrating required FRL and compliance with this clause must be provided prior to the issue of a Construction Certificate.

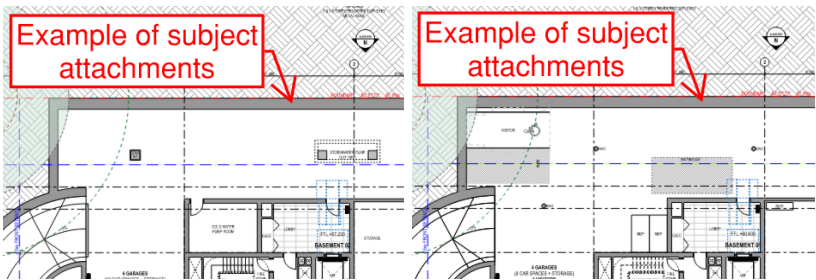
Part C2 – Fire Resistance and Stability																
Clause	Description	Status	Comments													
C2D10	Non-combustible building elements	CRA or PS	In a building required to be of Type A construction, the following building elements and their components must be non-combustible, concrete, masonry or fire protected timber:													
			<table border="1"> <thead> <tr> <th>Building Element</th> <th>Type A Construction</th> </tr> </thead> <tbody> <tr> <td>External wall</td> <td>Non-combustible</td> </tr> <tr> <td>Common wall</td> <td>Non-combustible</td> </tr> <tr> <td>Floor and floor framing of lift pit</td> <td>Non-combustible</td> </tr> <tr> <td>All loadbearing internal walls (including shaft walls)</td> <td>Concrete, masonry or fire-protected timber</td> </tr> <tr> <td>Loadbearing fire walls</td> <td>Concrete, masonry or fire-protected timber</td> </tr> <tr> <td>Non-loadbearing internal walls required to be fire-resistant</td> <td>Non-combustible</td> </tr> <tr> <td>Non-loadbearing lift, ventilating, pipe, garbage and like shafts which do not discharge hot products of combustion</td> <td>Non-combustible</td> </tr> </tbody> </table>	Building Element	Type A Construction	External wall	Non-combustible	Common wall	Non-combustible	Floor and floor framing of lift pit	Non-combustible	All loadbearing internal walls (including shaft walls)	Concrete, masonry or fire-protected timber	Loadbearing fire walls	Concrete, masonry or fire-protected timber	Non-loadbearing internal walls required to be fire-resistant
Building Element	Type A Construction															
External wall	Non-combustible															
Common wall	Non-combustible															
Floor and floor framing of lift pit	Non-combustible															
All loadbearing internal walls (including shaft walls)	Concrete, masonry or fire-protected timber															
Loadbearing fire walls	Concrete, masonry or fire-protected timber															
Non-loadbearing internal walls required to be fire-resistant	Non-combustible															
Non-loadbearing lift, ventilating, pipe, garbage and like shafts which do not discharge hot products of combustion	Non-combustible															
<p>Attachments</p> <p>Proposed attachments are to comply with the requirements of C2D10 and C2D14 of the BCA as applicable:</p>  <p>Should materials that do not form part of a tested system be utilised such as Dintel, AFS Rediwall or the like, design certification verifying compliance to be provided or alternatively a fire engineering performance solution can be undertaken prior to the issue of the Construction Certificate.</p>																
C2D11	Fire hazard properties	CRA	<p>The fire hazard properties of all floor materials, floor coverings, wall and ceiling lining materials must comply with Specification 7. The fire hazard properties of all other materials must comply with Specification 7.</p> <p>Design certification will be required verifying compliance prior to the issue of a Construction Certificate.</p>													
C2D12	Performance of external walls in fire	N / A	Concrete external walls that could collapse as complete panels (e.g. tilt-up and pre-cast concrete), in a building having a rise in storeys of not more than 2, must comply with Specification 8.													



Part C2 – Fire Resistance and Stability			
Clause	Description	Status	Comments
C2D13	Fire-protected timber: Concession	N / A	
C2D14	Ancillary elements	CRA	<p>An ancillary element must not be fixed, installed, attached to or supported by the internal parts or external face of an external wall that is required to be non-combustible unless it is determined to meet certain fire properties and limitations on the extent of coverage.</p> <p>Design certification will be required verifying compliance prior to the issue of a Construction Certificate.</p>
C2D15	Fixing of bonded laminated cladding panels	CRA	<p>In a building required to be of Type A or B construction, externally located bonded laminated cladding panels must have all layers of cladding mechanically supported or restrained to the supporting frame.</p> <p>Design certification will be required verifying compliance prior to the issue of a Construction Certificate.</p>

Part C3 – Compartmentation and Separation			
Clause	Description	Status	Comments
C3D1	Deemed-to-Satisfy Provisions	-	-
C3D2	Application of Part	Noted	Clauses C3D3, C3D4 and C3D5 do not apply to a sprinkler protected carpark, open deck carpark or open spectator stand.
C3D3	General floor area and volume limitations	CRA	All parts of the building comply and are within compartment limitations.
C3D4	Large isolated buildings	N / A	
C3D5	Requirements for open spaces and vehicular access	N / A	
C3D6	Class 9 buildings	N / A	
C3D7	Vertical separation of Openings in external walls	CRA	<p>In a building of Type 'A' construction that is not sprinkler protected, a spandrel must be provided. The spandrel must be not less than 900mm in height, extended not less than 600mm above the upper surface of the intervening floor and be of non-combustible material having an FRL of not less than 60/60/60.</p> <p>Alternatively, a slab or other horizontal construction that projects outwards not less than 1100mm beyond the external face of the wall and extends 450mm beyond the opening and be of non-combustible material having an FRL of not less than 60/60/60.</p> <p>The building is expected to be protected with a sprinkler system compliant with Clause E1D4 and Specification 17 of the BCA.</p> <p>Please note: if the building is to obtain a fire engineering performance solution to delete the sprinkler system, all spandrels throughout the building are to comply with the requirements of this Clause.</p> <p>Designer verification to be provided prior to the issue of the Construction Certificate.</p>
C3D8	Separation by fire walls	CRA	<p>If fire walls are used to separate the Lower Ground 2 residential SOU from the Class 7a carpark and 9b wellness centre, and the Lower Ground 1 residential SOU from the Class 7a carpark, the fire walls are to achieve the FRLs required under Tables S5C11a–g and S5C19 (if the car park is sprinkler protected) of Specification 5 of the BCA.</p> <p>Any openings within the fire wall must not reduce the FRL of the fire wall required by Specification 5, except when permitted by the DTS provisions of Part C4.</p> <p>All doors in the fire walls must comply with Clause C4D6 of the BCA.</p> <p>Refer to 'Appendix' A for the relevant fire resisting requirements. Plans to reflect required FRLs prior to the issue of a Construction Certificate.</p>



Part C3 – Compartmentation and Separation

Clause	Description	Status	Comments
--------	-------------	--------	----------

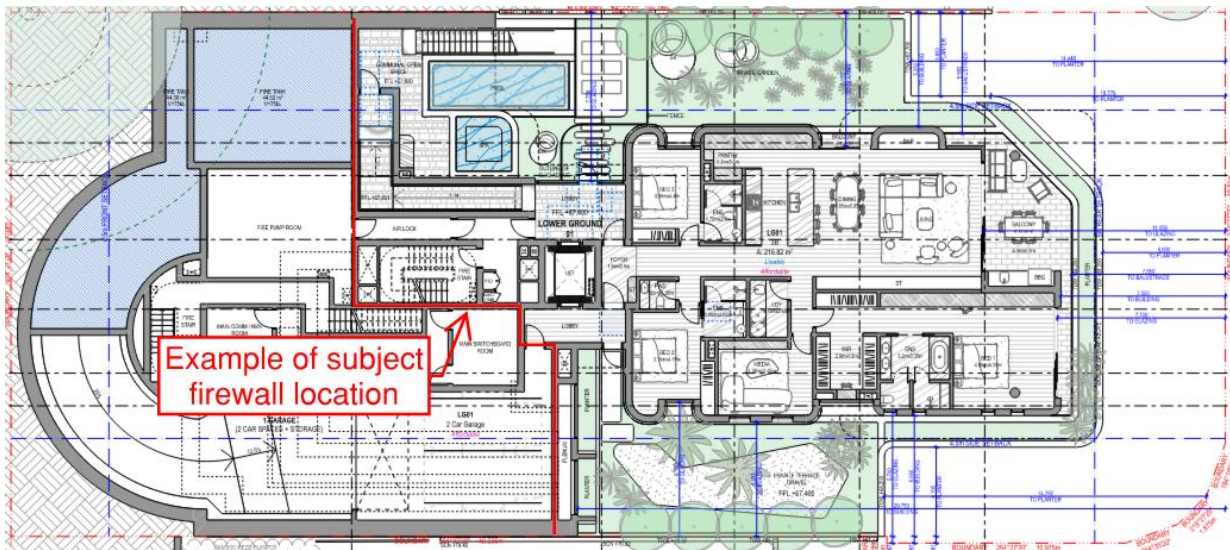
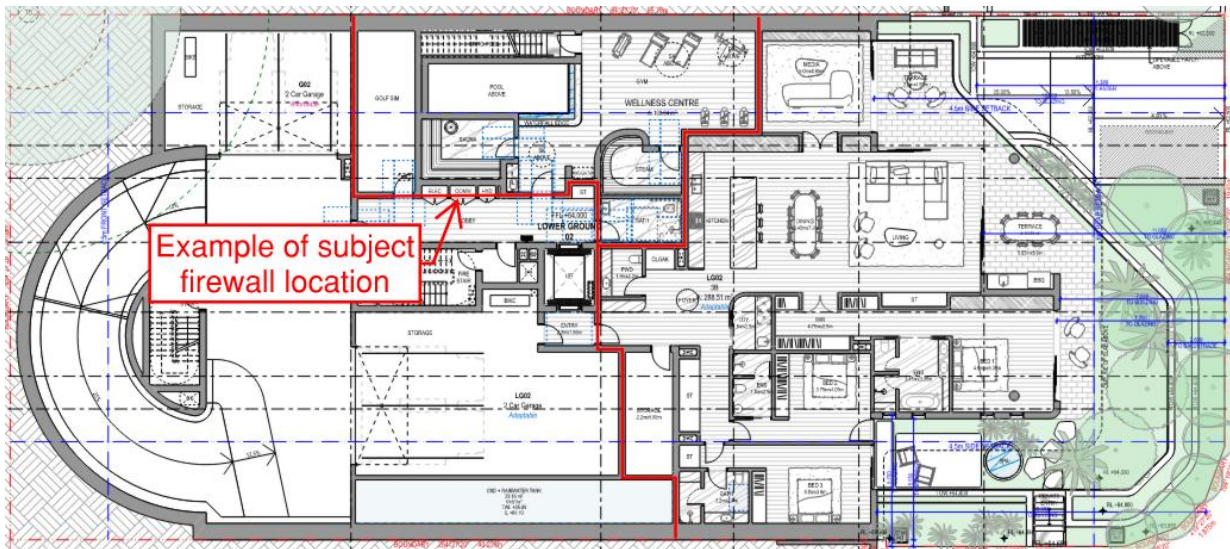

C3D9	Separation of classifications in the same storey	CRA	<p>The residential SOUs may be separated from the Class 7a and 9b areas using either of the following methods which include:</p> <ul style="list-style-type: none"> • All building elements of the Lower Ground 2 floor level are to be constructed using the higher FRL prescribed in Specification 5 of the BCA for the Class 7a carpark or 9b gym; • All building elements of the Lower Ground 1 floor level are to be constructed using the higher FRL prescribed in Specification 5 of the BCA for the Class 7a carpark; or • The relevant parts must be separated in that storey by a fire wall having the higher FRL prescribed in Table S5C11d of Specification 5. <p>Refer to 'Appendix' A for the relevant fire resisting requirements. Plans to reflect required FRLs prior to the issue of a Construction Certificate.</p>
------	--	-----	---

Part C3 – Compartmentation and Separation			
Clause	Description	Status	Comments
C3D10	Separation of classifications in different storeys	CRA	<p>The floor slab separating the different storeys require an FRL of:</p> <ul style="list-style-type: none"> Basement 2/basement 1 FRL 120/120/120; Basement 1/lower ground 2 floor FRL 120/120/120; Lower ground 2/lower ground 1 floor FRL to be determined by designer prior to the issue of the Construction Certificate; Lower ground 1/ground floor FRL to be determined by designer prior to the issue of the Construction Certificate; Ground/first floor FRL 90/90/90; First/second floor FRL 90/90/90; Second/third floor FRL 90/90/90; Third/fourth floor FRL 90/90/90; Fourth/fifth floor FRL 90/90/90; and Fifth/ sixth Floor 90/90/90. <p>Note: Floors within the same Class 2 SOU are not required to achieve an FRL as specified in Specification 5 of the BCA.</p> <p>Refer to 'Appendix' A for the relevant fire resisting requirements. Plans to reflect required FRLs prior to the issue of a Construction Certificate.</p>

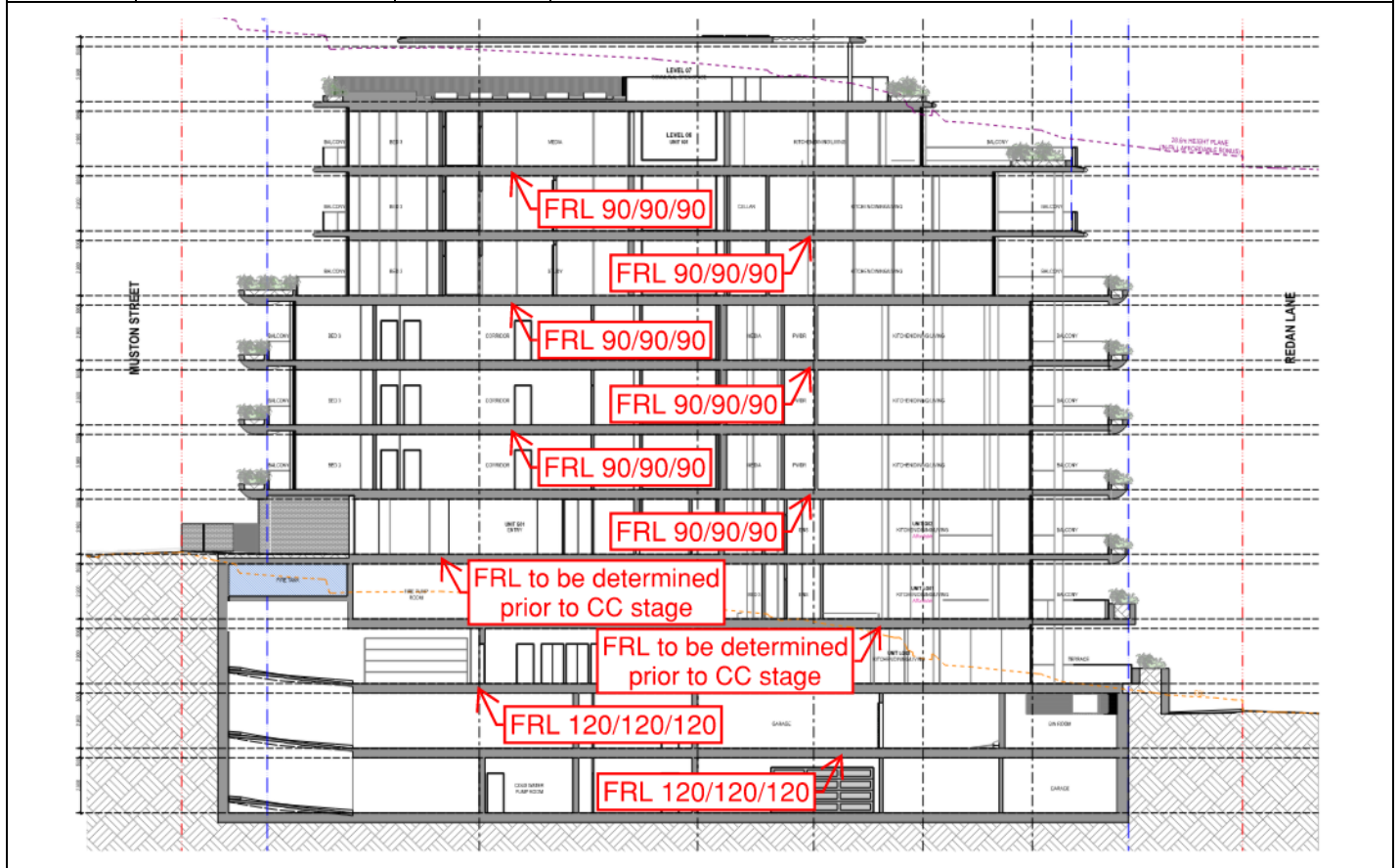

Part C3 – Compartmentation and Separation			
Clause	Description	Status	Comments
C3D11	Separation of lift shafts	CRA	<p>Any lift connecting more than 2 storeys building must be separated from the remainder of the building with material that achieves a FRL appropriate to that storey as required by Specification 5 and if required to be an emergency lift of not less than 120/120/120.</p> <p>Any opening in the fire-isolated lift shaft must be protected in accordance with Clause C4D11 of the BCA.</p> <p>Design verification to be provided prior to the issue of the Construction Certificate.</p>
C3D12	Stairways and lifts in one shaft	CRA	<p>A stairway and lift must not be in the same shaft if either the stairway or the lift is required to be in a fire-resisting shaft.</p> <p>Both the stairways & lifts appear to be in separate shafts.</p>
C3D13	Separation of equipment	CRA	<p>Equipment that comprises lift motors, lift control panels, central smoke control plant, boilers or batteries must be separated from the remainder of the building by construction with an FRL as required under Specification 5 but not less than 120/120/120 and any doorways in that construction protected with a self-closing –/120/30 fire door.</p> <p>Design certification will be required verifying compliance prior to the issue of a Construction Certificate.</p>
<p>Note: Clause 6.11.2 of AS 2419.1-2021 requires that an internal pumproom located within the building shall have the following:</p> <ul style="list-style-type: none"> • A door opening to a road or open space, or a door opening to fire-isolated passage or stair which leads to a road or open space; and • Except where the building is sprinkler protected in accordance with AS 2118.1, AS 2118.4, AS 2118.6 or FPAA101H, enclosing walls with an FRL not less than that prescribed by the BCA for a firewall for the particular building classifications served by the fire hydrant system. 			
C3D14	Electricity supply system	CRA	<p>The following electricity supply equipment:</p> <ul style="list-style-type: none"> • electrical substation (TBA) • main switchboard which sustains emergency equipment operating in emergency mode (TBA) • electricity conductors which supply substation or main switchboard (TBA) <p>Must be separated from the remainder of the building by construction with an FRL of not less than 120/120/120 and any doorways in that construction protected with a self-closing –/120/30 fire door.</p> <p>Final details verifying compliance can be provided on plans prior to the issue of a Construction Certificate.</p>
C3D15	Public corridors in Class 2 and 3 buildings	CRA	<p>In a Class 2 or 3 building, a public corridor, if more than 40 m in length, must be divided at intervals of not more than 40 m with smoke-proof walls complying with S11C2.</p> <p>Design certification will be required verifying compliance prior to the issue of a Construction Certificate.</p>

Part C4 – Protection of Openings			
Clause	Description	Status	Comments
C4D1	Deemed-to-satisfy Provisions	-	-
C4D2	Application of Part	Noted	Concessions and definition of certain openings.
C4D3	Protection of openings in external walls	PS	<p>Openings within 3m of an allotment boundary shall be protected by sprinklers, fire doors, fire windows etc, in accordance with Clause C4D5 of the BCA.</p> <p>Compliance can be achieved via a fire engineering performance solution undertaken prior to the issue of the Construction Certificate.</p>

The following external wall openings are located within 3m from fire source feature:

Lower Ground 2

- The eastern facing external wall opening of the Media Room within Unit LG02; and
- The eastern facing external wall opening of Bed 3 within Unit LG02.

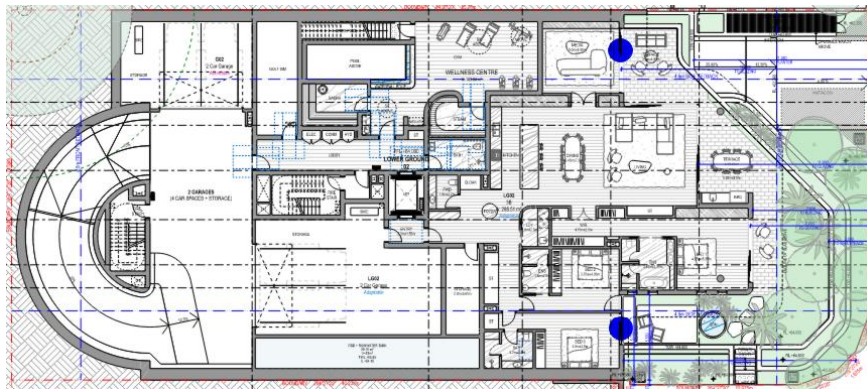

Lower Ground 2

- The eastern facing external wall opening of the residential corridor; and
- The western facing external wall opening of the residential corridor.

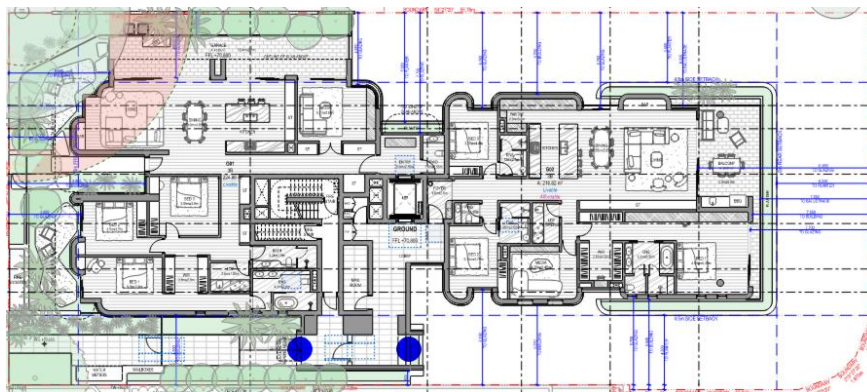

Compliance can be achieved via compliance with Clause C4D5 and Specification 12 of the BCA or alternatively a fire engineering performance solution can be undertaken prior to the issue of the Construction Certificate.

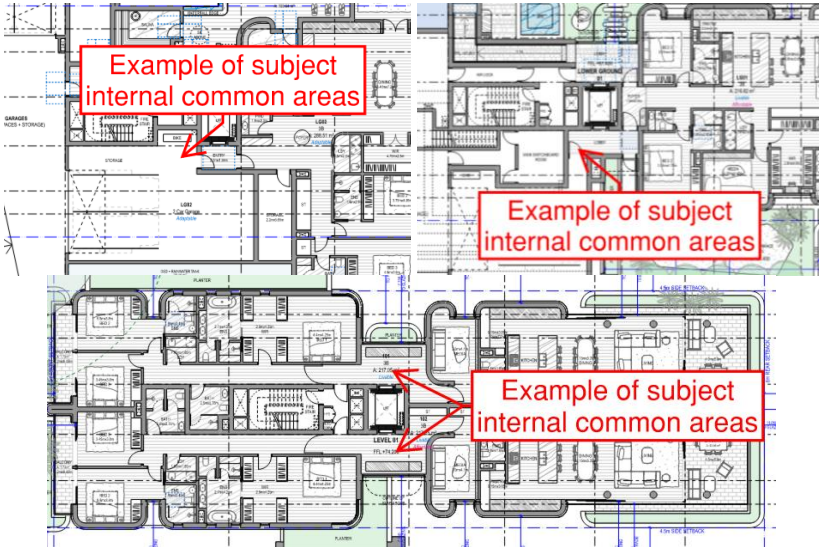

Part C4 – Protection of Openings			
Clause	Description	Status	Comments
C4D4	Separation of external walls and associated openings in different fire compartments	CRA	If fire walls are provided, refer to 'Appendix' A for the relevant fire resisting requirements of the fire wall. Plans to reflect required FRLs and location of fire walls (if any are proposed) prior to the issue of a Construction Certificate.
C4D5	Acceptable methods of protection	PS	<p>Window openings that are required to be protected are to be protected by wall wetting sprinklers with windows that are automatic closing or permanently fixed in the closed position, --/60/-- fire windows or --/60/60 automatic fire shutters.</p> <p>Other openings that required to be protected are to be protected by internal or external wall-wetting sprinklers or have construction with an FRL not less than --/60/--.</p> <p>Alternatively a fire engineering performance solution can be undertaken to achieve compliance with the performance requirements of the BCA.</p> <p>Plans to reflect required FRLs and location of openings protected in accordance with Clause C4D5 of the BCA prior to the issue of a Construction Certificate.</p>
C4D6	Doorways in fire walls	CRA	<p>If the ground floor wellness area is to be separated using fire walls, all doors in the fire walls are to be protected in accordance with Clause C4D6 of the BCA.</p> <p>Design certification will be required verifying compliance prior to the issue of a Construction Certificate.</p>
C4D7	Sliding fire doors	N / A	
C4D8	Protection of doorways in horizontal exits	Noted	
C4D9	Openings in fire isolated exits	CRA	<p>--/60/30 self-closing fire doors are required to doorways providing access to fire isolated passageways.</p> <p>Details verifying compliance must be provided on plans prior to the issue of a Construction Certificate.</p>
C4D10	Service penetrations in fire isolated exits	CRA	<p>Where provided, fire-isolated exits must not be penetrated by any services other than electrical wiring for essential fire service installations, pressurisation ducts with an FRL of --/120/60, or water pipes for fire services are not permissible.</p> <p><i>Note: Due care to be taken by services consultants to ensure compliance.</i></p> <p>Details verifying compliance must be provided on plans prior to the issue of a Construction Certificate.</p>

Part C4 – Protection of Openings			
Clause	Description	Status	Comments
C4D11	Openings in fire isolated lift shafts	CRA	<p>Openings in lift shafts are to be protected by –/60/– fire doors complying with AS1735.11.</p> <p>Lift indicator panels are to be backed by construction having an FRL of not less than –/60/60 if it exceeds 35,000mm² (175mm X 200 mm).</p> <p>Details verifying compliance must be provided on plans prior to the issue of a Construction Certificate.</p>
C4D12	Bounding construction: Class 2 and 3 buildings and Class 4 parts	PS	<p>As this building is Type ‘A ‘construction, doorways of the Class 2 residential sole occupancy units which open into the enclosed common corridors or the like are to be fitted with self-closing FRL –/60/30 fire doors.</p> <p>Additionally, in a Class 2 building where a path of travel to an exit does not provide a person seeking egress with a choice of travel in different directions to alternative exits and is along an open balcony, landing or the like and passes an external wall of another sole-occupancy unit or a room not within a sole-occupancy unit, then that external wall must have any windows or other openings located at least 1.5 m above the floor of the balcony, landing or the like or protected internally in accordance with C4D5.</p> <p>Residential Common Areas</p> <p>The internal common areas within the enclosed residential corridors of the residential floors may not be adequately fire separated with a fire rated wall and doorway as required by this Clause.</p>  <p>Compliance can be achieved via undertaking a fire engineering performance solution prior to the issue of the Construction Certificate.</p>

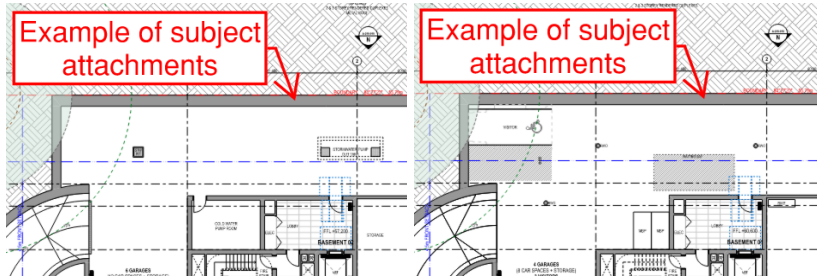
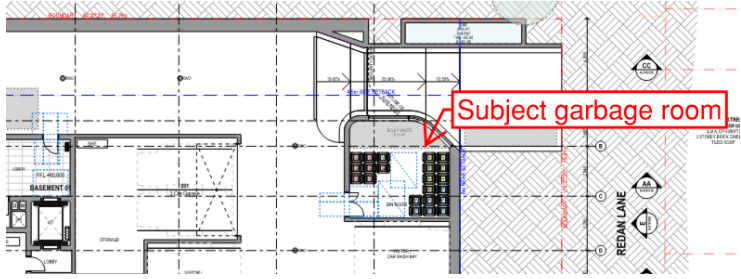
Part C4 – Protection of Openings			
Clause	Description	Status	Comments
			<p>Please also note 2 points:</p> <p>1: Walls within Class 2 and 3 buildings require Sound Ratings under F7. SOU doors are to incorporate an assembly which as an Rw not less than 30 from common areas.</p> <p>2: The SOU doors however still need to transmit at least 85 or 100 dB(A) depending on the alarms system selected under S2OC6, as part of the Building Occupant Warning System. Occupants within the unit need to hear the buildings alarm system.</p>
C4D13	Openings in floors and ceilings for services	CRA	<p>Services passing through floors are to be placed within fire resisting shafts or in accordance with Clause C4D15.</p> <p>Details verifying compliance must be provided on plans prior to the issue of a Construction Certificate.</p>
C4D14	Openings in shafts	CRA	<p>In a building of Type A construction, an opening in a wall providing access to a ventilating, pipe, garbage, or other service shaft must be protected by:</p> <ul style="list-style-type: none"> • If it is a sanitary compartment - a door or panel which together with its frame, is non-combustible or has an FRL of not less than –/30/30, or • A self-closing –/60/30 fire door or hopper, or • An access panel with an FRL of not less than –/60/30, or • If the shaft is a garbage shaft - a door or hopper of non-combustible construction. <p>Details verifying compliance must be provided on plans prior to the issue of a Construction Certificate.</p>
C4D15	Openings for service installation	CRA	<p>Where services (e.g. hydraulic, mechanical, plumbing, electrical) penetrate a building element that is required to achieve an FRL with respect to integrity or insulation or a resistance to the incipient spread of fire then that installation must be protected / sealed (e.g. fire collars, fire dampers etc) by material that is identical to tested prototypes and in accordance with AS4072.1 and AS1530.4, and having achieved the required FRL or resistance to the incipient spread of fire or other specified method.</p> <p>Details verifying compliance must be provided on plans prior to the issue of a Construction Certificate.</p>
C4D16	Construction Joints	CRA	<p>Construction joints are to be installed in accordance with a tested prototype in accordance with AS1530.4.</p> <p>Details verifying compliance must be provided on plans prior to the issue of a Construction Certificate.</p>
C4D17	Columns protected with lightweight construction	CRA	<p>Columns must be protected in accordance with the identical tested prototype.</p> <p>Details verifying compliance must be provided on plans prior to the issue of a Construction Certificate.</p>

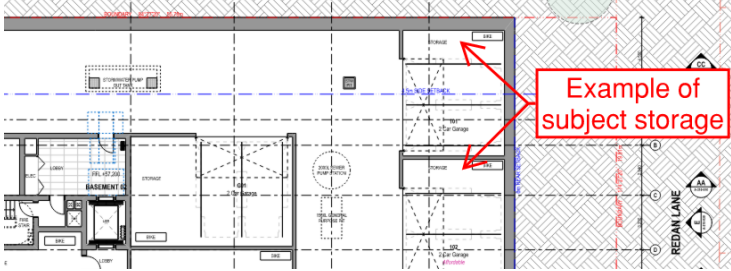
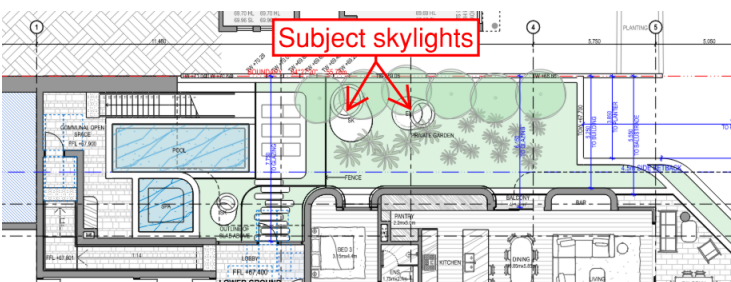
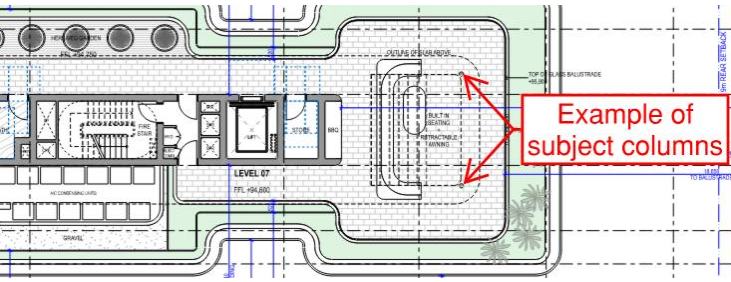
Specification 5–Fire-Resisting Construction			
Clause	Description	Status	Comments
Spec 5	Requirements for Type A construction	PS	<p>Clause C2D2 requires the building to be constructed as Type A construction in accordance with Part S5C2–S5C20, Part S5C11–S5C20 and Tables S5C11a–g of Specification 5 of the BCA.</p> <p>External Walls</p> <p>All load-bearing and non-load-bearing bounding walls are required to achieve an FRL tested from both sides as stipulated by Tables S5C11a–g of Specification 5.</p> <p>Attachments</p> <p>All attachments are to comply with the requirements in Specification 5 & Clause C2D11 and meet the intent of Clause S5D5 of Spec 5.</p>  <p>Should material that does not form part of a tested system be utilised such as Dincel, AFS Rediwall or the like, compliance can be achieved via a fire engineering performance solution undertaken prior to the issue of the Construction Certificate.</p> <p>Garbage Room</p> <p>The Basement garbage room is to be enclosed with FRL 120/120/120 construction and fitted with FRL –/120/30 fire doors in accordance with Specification 5 of the BCA.</p>  <p>Storage Room(s)</p> <p>Storage within the basement and lower ground floor carpark appears to be greater than 10% of the total floor area.</p>

Specification 5–Fire-Resisting Construction			
Clause	Description	Status	Comments
			 <p>Example of subject storage</p> <p>Skylights</p> <p>All skylights are to comply with the requirements of Clause S5C16 in Specification 5, and must be located not less than 3m from the side boundary, 3m from skylights in adjoining sole-occupancy units and 3m from windows from sole-occupancy units above.</p>  <p>Subject skylights</p> <p>Fire Rated Supporting Columns</p> <p>Any external columns supporting the roof structure or any awnings are required to achieve an FRL in accordance with Tables S5C11a–S5C11g of Specification 5.</p>  <p>Example of subject columns</p> <p>Vertical and Horizontal Cavity Barriers</p> <p>Required vertical and horizontal cavity barriers to be provided between different fire compartments and between storeys. Designer to confirm if a tested system is available.</p>

Specification 5–Fire-Resisting Construction			
Clause	Description	Status	Comments
			 <p>Example of subject cavity barriers</p> <p>Fire Rated Shelf Angles Any shelf angles provided to the building are to achieve the same FRL as the slab in which it is attached to.</p>  <p>Example of subject shelf angles</p> <p>Fire Rated Lintels All lintels within walls throughout the building are required to be fire rated.</p> <p>Open State Cavity Barriers Open state cavity barriers are required to achieve an FRL in accordance with Tables S5C11a–S5C11g of Specification 5.</p> <p>Non-Combustible Walls All loadbearing external and internal walls are required to be of non-combustible construction in accordance with Clauses C2D10, C2D11, C2D14 and Specification 5. AFS Rediwall or Dincel products are not considered to be non-combustible as required.</p> <p>Details verifying compliance must be provided on plans or alternatively a fire engineering performance solution can be undertaken prior to the issue of the Construction Certificate.</p>

SECTION D – ACCESS AND EGRESS

Part D2 – Provision for Escape			
Clause	Description	Status	Comments
D2D1	Deemed-to-Satisfy Provisions	-	-
D2D2	Application of Part	Noted	Does not apply to the internal parts of a sole occupancy unit in a Class 2, 3 or 4 building.
D2D3	Number of exits required	PS	<p>Building has effective height of more than 25m.</p> <p>The basement floors, lower ground floors, ground floor and residential parts of the building are required to be provided with not less than two (2) exits.</p> <p>Lower ground 2, residential levels and seventh floor of the building are provided with a single exit stairway in lieu of two (2) exits.</p> <p>The lower ground floor 1 carpark does not appear to be provided with an exit. An exit door with an airlock is proposed to be provided with a performance solution.</p> <p>Compliance to be achieved by a fire engineering performance solution to be conducted prior to the issuance of the Construction Certificate.</p>
D2D4	When fire-isolated stairways and ramps are required	CRA	<p>In a Class 2 building, a required non-fire-isolated stairway is permitted if it connects, passes through or passes by not more than 3 consecutive storeys and one extra storey if it is only for the accommodation of motor vehicles or for other ancillary purposes, or the building has a sprinkler system (other than a FPAA101D system) complying with Specification 17 installed throughout.</p> <p>In a Class 5, 6, 7, 8 or 9 building, every stairway or ramp serving as a required exit must be fire-isolated unless it connects, passes through or passes by not more than 2 consecutive storeys and one extra storey of any classification may be included if—</p> <ul style="list-style-type: none"> • the building has a sprinkler system (other than a FPAA101D system) complying with Specification E1.5 installed throughout; or • the required exit does not provide access to or egress for, and is separated from, the extra storey by construction having— <ul style="list-style-type: none"> ○ an FRL of –/60/60, if non-loadbearing; and ○ an FRL of 90/90/90 for Type A construction or 60/60/60 for Type B construction, if loadbearing; and ○ no opening that could permit the passage of fire or smoke. <p>The stairway(s) appear to comply with the requirements of this Clause. Please refer to Clause D2D12 and Clause D2D14 for further details.</p>

Part D2 – Provision for Escape			
Clause	Description	Status	Comments
D2D5	Exit travel distances	PS	<p>The entrance doorway of any sole-occupancy unit must be not more than 6 m (increased to 12 m if the building is provided with a required automatic fire sprinkler system in accordance with Specification 18) from an exit or from a point from which travel in different directions to 2 exits is available or 20 m from a single exit serving the storey at the level of egress to a road or open space.</p> <p>No point on the floor of a room which is not in a sole-occupancy unit must be more than 20 m from an exit or from a point at which travel in different directions to 2 exits is available.</p> <p>No point on a floor of a Class 9 building must be more than 20 m from an exit, or a point from which travel in different directions to 2 exits is available, in which case the maximum distance to one of those exits must not exceed 40 m.</p> <p>In a Class 9b building other than a school or early childhood centre, the distance to one of the exits may be 60 m if:</p> <ul style="list-style-type: none"> the path of travel from the room concerned to that exit is through another area which is a corridor, hallway, lobby, ramp or other circulation space; and the room is smoke-separated from the circulation space by construction having an FRL of not less than 60/60/60 with every doorway in that construction protected by a tight fitting, self-closing, solid-core door not less than 35 mm thick; and the maximum distance of travel does not exceed 40 m within the room and 20 m from the doorway to the room through the circulation space to the exit. <p>Compliance can be achieved by a fire engineering performance solution undertaken prior to the issue of the Construction Certificate.</p>

Basement 2 & 1 Carpark

The following travel distances from the basement carpark exceed 20m to a point of choice.

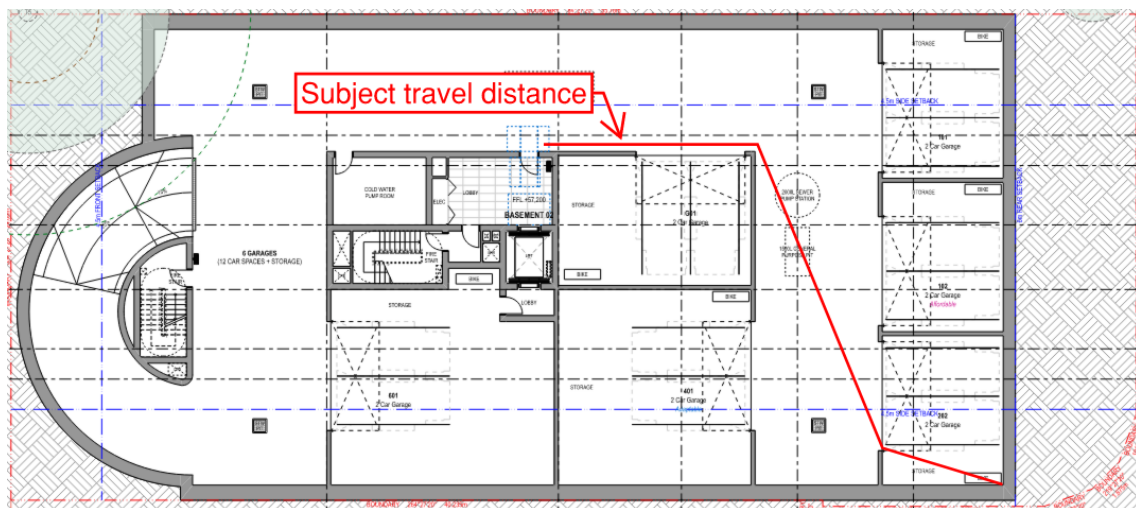

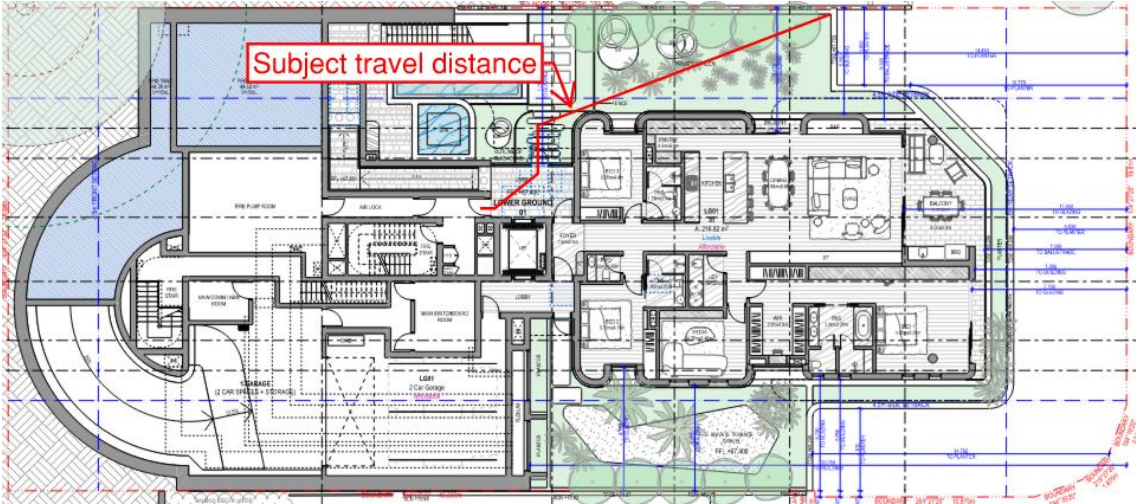
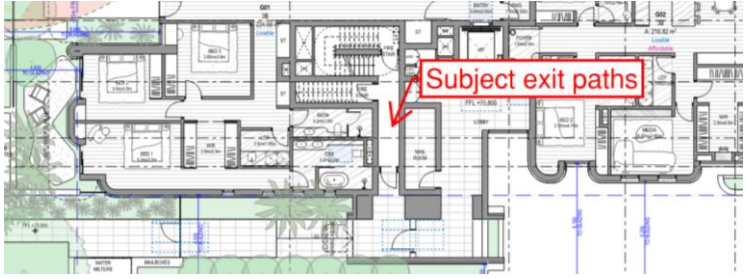
Part D2 – Provision for Escape			
Clause	Description	Status	Comments
Lower Ground 1			
The following travel distances from the Lower Ground 1 exceeds 20m to a point of choice.			
			
D2D6	Distances between alternative exits	PS	<p>Storeys requiring two or more exits have exits distributed within 45m for the Class 2 and 60m for the Class 7a & 9b parts from one another and are also further than 9m apart. The paths of travel leading to alternative exits must not converge within 6m.</p> <p>Ground Floor Level</p> <p>The subject exits on the Ground Floor are not provided as far as practically possible. In addition, the alternative exit paths in the converge within 6m of each other.</p>  <p>Compliance can be achieved by a fire engineering performance solution undertaken prior to the issue of the Construction Certificate.</p>
D2D7	Height of exits, paths of travel to exits and doorways	CRA	<p>In a required exit or path of travel, the unobstructed height throughout must be not less than 2m, except the unobstructed height of any doorway must be reduced to not less than 1980mm.</p> <p>Height of exits, paths of travel and doorways in the building appear to comply with the requirements of this clause.</p> <p>Design verification to be provided by the designer prior to the issue of the Construction Certificate.</p>

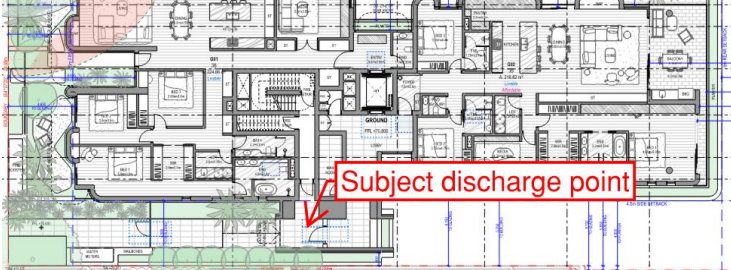
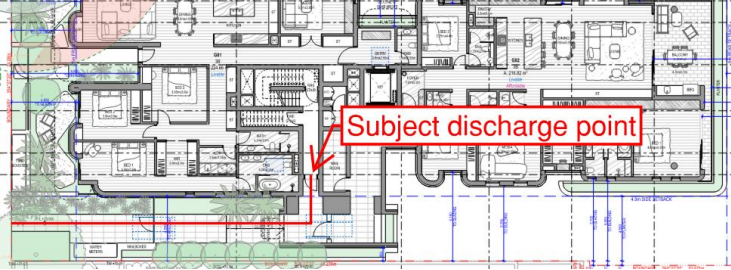

Part D2 – Provision for Escape			
Clause	Description	Status	Comments
D2D8	Width of exits and paths of travel to exits	CRA	<p>The unobstructed width of each exit or path of travel to an exit, except for ladders and doorways, must not be less than 1m.</p> <p>Note: all service and common areas such as the residential bin storage room are required to be provided with a clear exit width of 1m.</p> <p>Non-Fire Isolated Stairways and Ramps</p> <p>All non- fire isolated stairways and ramps serving the building must include double handrails and tactile indicators in accordance with AS 1428.1-2021.</p> <p>Please note: Internal non-fire isolated stairs must incorporate double handrail as required under D4, stairs are to be >1.2m wide to cater for this requirement.</p> <p>The fire isolated exit stairways must incorporate a single handrail as required by the BCA, the stairs are to be >1.1m wide to cater for the requirement.</p> <p>Width of exits and paths of travel in the building appear to comply with the requirements of this clause.</p> <p>Design verification to be provided by the designer prior to the issue of the Construction Certificate.</p>
D2D9	Width of doorways in exits or paths of travel to exits	CRA	<p>The unobstructed width of a doorway in a required exit or path of travel to exit must not be less than 750mm.</p> <p>Width of doorways in paths of travel in the building appear to comply with the requirements of this clause.</p> <p>Design verification to be provided by the designer prior to the issue of the Construction Certificate.</p>
D2D10	Exit width not to diminish in direction of travel	CRA	<p>The unobstructed width of a required exit must not diminish in the direction of travel to a road or open space.</p> <p>Design verification to be provided by the designer prior to the issue of the Construction Certificate.</p>
D2D11	Determination and measurement of exits and paths of travel to exits	CRA	<p>The unobstructed width of a stairway or ramp in a required exit or path of travel to an exit must be measured clear of all obstructions such as handrails, projecting parts of balustrades or other barriers and the like.</p> <p>The unobstructed height of a stairway or ramp in a required exit or path of travel to an exit must extend without interruption, except for ceiling cornices, to a height not less than 2m vertically above a line along the nosing of the treads or the floor surface of the ramp or landing.</p> <p>Design verification to be provided by the designer prior to the issue of the Construction Certificate.</p>

Part D2 – Provision for Escape			
Clause	Description	Status	Comments
D2D12	Travel via fire-isolated exits	PS	<p>Each fire-isolated stairway or fire-isolated ramp must provide independent egress from each storey served and discharge directly, or by way of its own fire-isolated passageway, either:</p> <ul style="list-style-type: none"> • Direct: to a road or open space; or • Open Area: to a point in a storey or space, within the confines of the building, that is used only for pedestrian movement, car parking or the like and is open for at least 2/3 of its perimeter; and from which an unimpeded path of travel, not further than 20 m, is available to a road or open space; or • Covered Area: into a covered area that adjoins a road or open space, is open for at least 1/3 of its perimeter, has an unobstructed clear height throughout of not less than 3 m (inc. perimeter openings), and provides an unimpeded path of travel from the point of discharge to the road or open space of not more than 6 m. <p>Open Area Discharge Points</p> <p>The current design of numerous stairways serving the residential units discharges in an open area within the confines of the building not 2/3 of the perimeter open and/or is further than 20m to a road or open space.</p>  <p>External Wall Openings in Path of Travel</p> <p>The path of travel discharging from the stairways passes within 6m of external wall openings which are not protected in accordance with Clause C4D5 of the BCA.</p> 

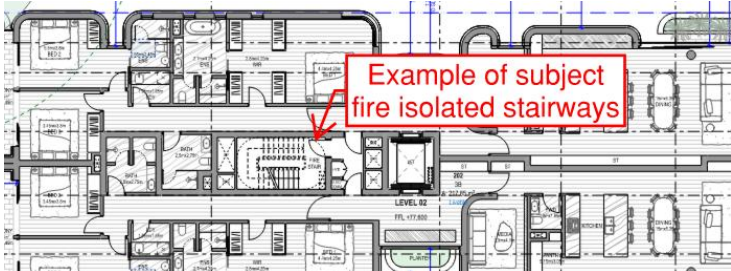
Part D2 – Provision for Escape			
Clause	Description	Status	Comments
			<p>Residential Stairways</p> <p>The residential SOUs throughout the building open directly into the fire-isolated stairways and contain either more than one (1) SOU or common area and SOU.</p>  <p>Compliance can be achieved via undertaking a fire engineering performance solution prior to the issue of the Construction Certificate.</p>
D2D13	External stairways or ramps in lieu of fire-isolated exits	CRA	<p>An external stairway or ramp may serve as a required exit in lieu of a fire-isolated exit serving a storey below an effective height of 25 m, if the stairway or ramp is:</p> <ul style="list-style-type: none"> • Non-combustible throughout; and • Protected in accordance with D1.8(c) if it is within 6 m of, and exposed to any part of the external wall of the building it serves. <p>Details verifying compliance must be provided on plans prior to the issue of a Construction Certificate.</p>
D2D14	Travel by Non-fire-isolated Stairways or ramps	CRA	<p>A required non-fire-isolated stairway or ramp must provide a continuous means of travel by its own flights and landings from every storey served to the level at which egress to a road or open space is provided.</p> <p>In a Class 2 building, the distance between the doorway of a sole-occupancy unit and a road or open space via a required non-fire-isolated stairway or ramp must not exceed 60m.</p> <p>A required non-fire-isolated stairway or ramp servicing the residential parts of the building must discharge at a point not more than 15 m from a road or open space or from a fire-isolated passageway leading to a road or open space.</p> <p>A required non-fire-isolated stairway or ramp servicing the carpark must discharge at a point not more than 20 m from a road or open space or from a fire-isolated passageway leading to a road or open space.</p> <p>Details verifying compliance must be provided on plans prior to the issue of a Construction Certificate.</p>
D2D15	Discharge from exits	CRA	<p>Suitable barriers such as bollards are to be provided to prevent the blockage of exits by vehicles, etc.</p> <p>All external ramps that are used as a path from an exit to a road must have a gradient not steeper than 1:8 at any part.</p>

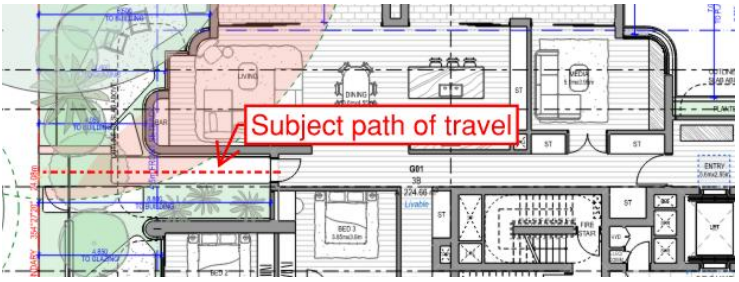
Part D2 – Provision for Escape			
Clause	Description	Status	Comments
			<p>Path of Travel to Street</p> <p>The subject path of travel to the street on the ground floor does not appear to be provided with a solid path of travel as required.</p>  <p>Compliance can be achieved via slight redesign prior to the issue of the Construction Certificate.</p>
D2D16	Horizontal exits	N / A	The current design does not consist of required horizontal exits.
D2D17	Non-required stairways, ramps or escalators	Noted	
D2D18	Number of persons accommodated	Noted	
D2D19	Measurement of distances	Noted	
D2D20	Method of measurement	Noted	
D2D21	Plant rooms, lift machine rooms and electricity network substations: Concession	N / A	
D2D22	Access to lift pits	CRA	Final details as to the lift shafts and pits are required.
<p>DANGER LIFTWELL – ENTRY OF UNAUTHORIZED PERSONS PROHIBITED – KEEP CLEAR AT ALL TIMES</p>			<p>(a) where the pit depth is not more than 3 m, be through the lowest landing doors; or</p> <p>(b) where the pit depth is more than 3 m, be provided through an access doorway complying with the following:</p> <ul style="list-style-type: none"> (i) In lieu of D2D7 to D2D11, the doorway must be level with the pit floor and not be less than 600 mm wide by 1980 mm high clear opening, which may be reduced to 1500 mm where it is necessary to comply with (ii). (ii) No part of the lift car or platform must encroach on the pit doorway entrance when the car is on a fully compressed buffer. (iii) Access to the doorway must be by a stairway complying with AS 1657.

Part D2 – Provision for Escape			
Clause	Description	Status	Comments
			<p>(iv) In lieu of D3D26, doors fitted to the doorway must be—</p> <p>(A) of the horizontal sliding or outwards opening hinged type; and</p> <p>(B) self-closing and self-locking from the outside; and</p> <p>(C) marked on the landing side with the letters not less than 35 mm high:</p> <p>“DANGER LIFTWELL – ENTRY OF UNAUTHORIZED PERSONS PROHIBITED – KEEP CLEAR AT ALL TIMES”</p>
D2D23	Egress from primary schools	N / A	The subject building does not contain any Class 9b primary school parts.

Part D3 – Construction of Exits			
Clause	Description	Status	Comments
D3D1	Deemed-to-Satisfy Provisions	-	-
D3D2	Application of Part	Noted	
D3D3	Fire-isolated stairways and ramps	CRA	<p>Stairway or ramps within the fire isolated shaft must be constructed on non-combustible materials and if there is a structural failure within the building, it would not cause structural damage to, or impair the fire resistance of the shaft.</p> <p>Engineering details are to be submitted with the Construction Certificate Documentation.</p>
D3D4	Non-fire-isolated stairways and ramps	CRA	<p>Required stairs that are not required to be within a fire-resting shaft are to be constructed of concrete, steel (6mm), or timber (44mm) of specified minimum dimensions.</p> <p>Engineering details are to be submitted with the Construction Certificate Documentation.</p>
D3D5	Separation of rising and descending stair flights	Noted	If a stairway serving as an exit is required to be fire-isolated, there must be no direct connection between a flight rising from a storey below the lowest level of access to a road or open space and a flight descending from a storey above that level. Furthermore, any construction that separates or is common to the rising and descending flights must be non-combustible; and smoke proof in accordance with Clause S11C2 of Specification 11.
D3D6	Open access ramps and balconies	N / A	
D3D7	Smoke lobbies	N / A	

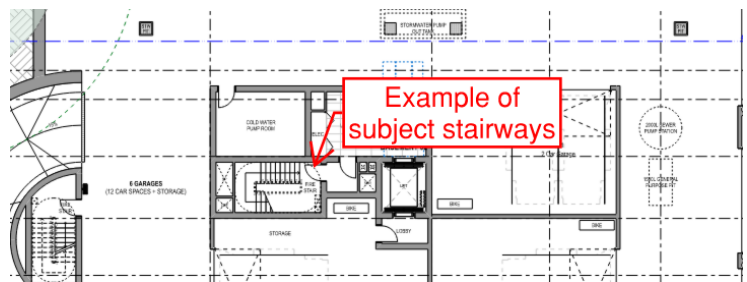
Part D3 – Construction of Exits			
Clause	Description	Status	Comments
D3D8	Installations in exits and paths of travel	PS	<p>Electrical boards and the like are to be located within and enclosed by non-combustible construction or have a fire-protective covering with the doorway suitably sealed against smoke spreading from the enclosure.</p> <p>Fire-Isolated Stairways</p> <p>No services or piping, other than the equipment and pipework required for the essential fire safety services, are to be provided within any of the fire isolated exits within the building (including rooms and storage throughout). Architect to cross-check all designer/engineering drawings to confirm.</p>  <p>Compliance can be achieved via undertaking a fire engineering performance solution prior to the issue of the Construction Certificate.</p>
D3D9	Enclosure of space under stairs and ramps	CRA	<p>The space below required fire-isolated stairs must not be enclosed to form a cupboard or similar enclosed space. The space below required non-fire-isolated stairs must not be enclosed unless the enclosing walls have an FRL of not less than 60/60/60 and any doorway to the enclosed space is fitted with a self-closing –/60/30 fire door.</p> <p>There is to be no form of cupboard or similar enclosed space within any of the required stairways.</p> <p>Design verification is to be provided prior to the issue of the Construction Certificate.</p>
D3D10	Width of required stairways and ramps	CRA	<p>Stairway width is to be measured clear of obstructions such as handrails, projecting parts of balustrades or other barriers and the like and extend to a height of not less than 2m.</p>
D3D11	Pedestrian ramps	CRA	<p>Ramps serving as a required exit must not have a gradient steeper than 1:8. If the ramp is required for disabled access under Part D4 it must comply with AS1428.1. The surface of the ramp must have a non-slip finish.</p> <p>Note: The floor surface of a ramp must have a slip-resistance classification not less than that listed in Table D3D15 of the BCA when tested in accordance with AS 4586-2013.</p>

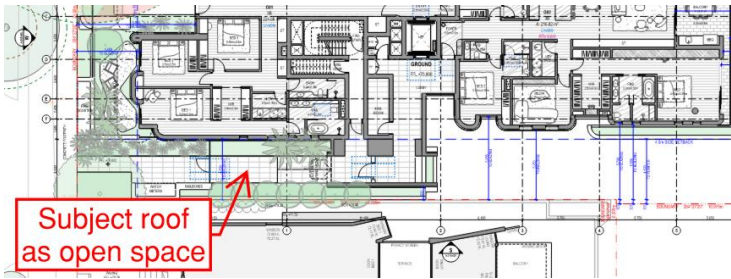

Part D3 – Construction of Exits			
Clause	Description	Status	Comments
D3D12	Fire-isolated passageways	CRA	<p>(1) The enclosing construction of a fire-isolated passageway must have an FRL when tested for a fire outside the passageway in another part of the building of—</p> <ul style="list-style-type: none"> (a) if the passageway discharges from a fire-isolated stairway or ramp — not less than that required for the stairway or ramp shaft; or (b) in any other case — not less than 60/60/60. <p>(2) Notwithstanding (1)(b), the top construction of a fire-isolated passageway need not have an FRL if the walls of the fire-isolated passageway extend to the underside of—</p> <ul style="list-style-type: none"> (a) a non-combustible roof covering; or (b) a ceiling having a resistance to the incipient spread of fire of not less than 60 minutes separating the roof space or ceiling space in all areas surrounding the passageway within the fire compartment. <p>Final details are to be submitted with the Construction Certificate Documentation.</p>
D3D13	Roof as open space	PS	<p>If an exit discharges to a roof of a building, the roof must have an FRL of not less than 120/120/120 and not have any rooflights or other openings within 3 m of the path of travel of persons using the exit to reach a road or open space.</p> <p>Ground Floor Open Space</p> <p>The subject Ground Floor rooftop area appears to be required to act as an open space as required by this clause.</p>  <p>Compliance can be achieved via undertaking a fire engineering performance solution prior to issue of the Construction Certificate.</p>

Part D3 – Construction of Exits																		
Clause	Description	Status	Comments															
D3D14	Goings and risers	CRA	<p>Stairs are to have risers measuring between 115-190mm and goings between 250-355.</p> <p>Goings and Risers are to satisfy the equation of $2R+G=700(\text{max}) \text{ and } 550(\text{min}).$</p> <p>Goings and risers are to be consistent throughout in one flight. Any gap between risers must not permit a 125mm sphere to pass through it.</p> <p>Ensure all stairways throughout the building do not contain less than 2 or more than 18 risers</p> <p>All treads and surfaces with a slip resistant classification are to be fitted with non-slip finish or non-skid strips compliant with the requirements of Table D3D15 when tested in accordance with AS4586-2013 and 30% colour contrasting nosings.</p> <p>Final details are to be submitted with the Construction Certificate Documentation.</p>															
D3D15	Landings	CRA	<p>Landings must comply with the requirements of Clause D3D15 of the BCA. Landings must be not less than 750mm long and have a non-slip finish throughout or an adequate non-skid strip near the edge of the landing where it leads to a flight below and 30% colour contrasting nosings.</p> <p>Strips at the edge of the landing with slip-resistance classification not less than that listed in Table D3D15 when tested in accordance with AS 4586-2013, where the edge leads to a flight below.</p> <p>Table D3D15 Slip-resistance classification</p> <table border="1"> <thead> <tr> <th>Application</th> <th>Dry surface conditions</th> <th>Wet surface conditions</th> </tr> </thead> <tbody> <tr> <td>Ramp steeper than 1:14</td> <td>P4 or R11</td> <td>P5 or R12</td> </tr> <tr> <td>Ramp steeper than 1:20 but not steeper than 1:14</td> <td>P3 or R10</td> <td>P4 or R11</td> </tr> <tr> <td>Tread or <u>landing</u> surface</td> <td>P3 or R10</td> <td>P4 or R11</td> </tr> <tr> <td>Nosing or <u>landing</u> edge strip</td> <td>P3</td> <td>P4</td> </tr> </tbody> </table> <p>Final details are to be submitted with the Construction Certificate Documentation.</p>	Application	Dry surface conditions	Wet surface conditions	Ramp steeper than 1:14	P4 or R11	P5 or R12	Ramp steeper than 1:20 but not steeper than 1:14	P3 or R10	P4 or R11	Tread or <u>landing</u> surface	P3 or R10	P4 or R11	Nosing or <u>landing</u> edge strip	P3	P4
Application	Dry surface conditions	Wet surface conditions																
Ramp steeper than 1:14	P4 or R11	P5 or R12																
Ramp steeper than 1:20 but not steeper than 1:14	P3 or R10	P4 or R11																
Tread or <u>landing</u> surface	P3 or R10	P4 or R11																
Nosing or <u>landing</u> edge strip	P3	P4																
D3D16	Thresholds	CRA	<p>A threshold of a doorway must not incorporate a step or ramp at any point closer to the doorway than the width of the door leaf unless the door opens to a road or open space, external stair landing or external balcony and the doorsill is not more than 190mm above the finished surface of the ground balcony or the like to which the door opens.</p> <p>Final details are to be submitted with the Construction Certificate Documentation.</p>															

Note: If the door is in a path of travel required to be accessible under D4, a step is not allowed.

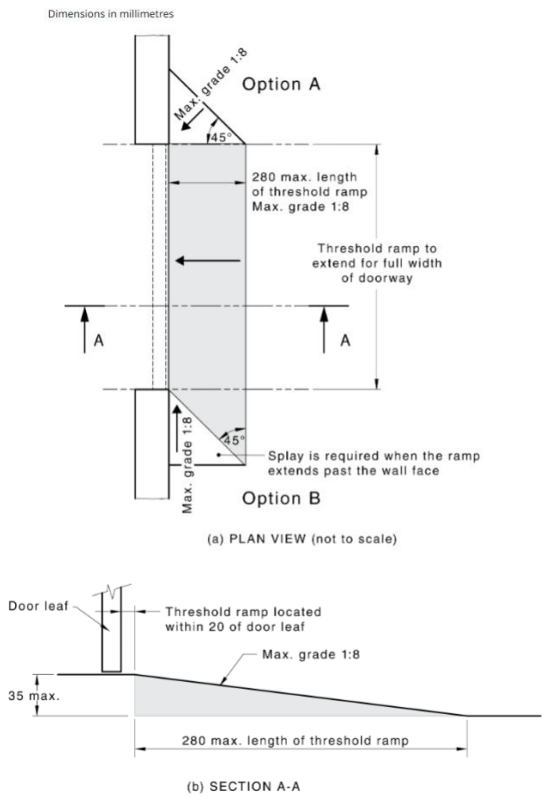
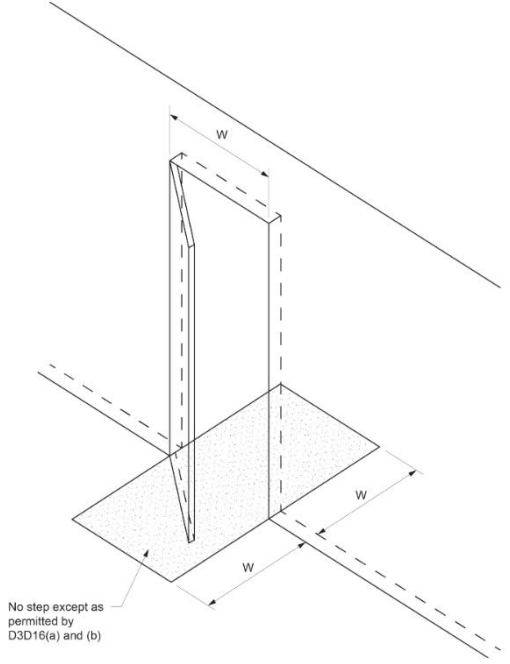
Note: This applies to all Fire Isolated Exit Doors also including the last exit door to open space.

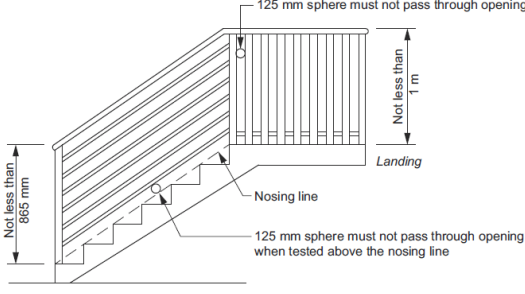
Part D3 – Construction of Exits			
Clause	Description	Status	Comments
	 <p>Dimensions in millimetres</p> <p>Option A</p> <p>Max. grade 1:8</p> <p>45°</p> <p>280 max. length of threshold ramp Max. grade 1:8</p> <p>Threshold ramp to extend for full width of doorway</p> <p>A</p> <p>Option B</p> <p>Max. grade 1:8</p> <p>45°</p> <p>Splay is required when the ramp extends past the wall face</p> <p>(a) PLAN VIEW (not to scale)</p> <p>Door leaf</p> <p>Threshold ramp located within 20 of door leaf</p> <p>Max. grade 1:8</p> <p>35 max.</p> <p>280 max. length of threshold ramp</p> <p>(b) SECTION A-A</p>		 <p>No step except as permitted by D3D16(a) and (b)</p>
D3D17	Barriers to prevent falls	Noted	<p>Balustrades complying with Deemed-to-Satisfy provisions of the BCA are to be provided to where the level of the surface below is 1m or more. Balustrades must also be provided where the level of the surface beneath is more than 4m where it is possible for a person to fall through an openable window.</p> <p>Final details are to be submitted with the Construction Certificate Documentation.</p>
D3D18	Height of barriers	CRA	<p>Where required by D3D17, the height of a barrier must be not less than:</p> <ul style="list-style-type: none"> • For stairways or ramps with a gradient of 1:20 or steeper: 865mm • For landings where the barrier is provided along the inside edge of the landing and does not exceed 500mm in length: 865mm • In front of fixed seating on a mezzanine or balcony in an auditorium in a Class 9b building: 700mm • For all other locations: 1m <p>Final details are to be submitted with the Construction Certificate Documentation.</p>
D3D19	Openings in barriers	CRA	<p>Openings in barriers are required to comply with Clause D3D19.</p>

Part D3 – Construction of Exits			
Clause	Description	Status	Comments
			<p>Any opening in the balustrade must not permit a 125mm sphere to pass through the balusters.</p> <p>Fire isolated stairways, ramps or other areas used primarily for emergency purposes must not permit a 300mm sphere to pass through. Where rails are used, a 150mm sphere must not be able to pass through the opening, and the opening between rails must not be more than 460mm.</p> <p>Details demonstrating compliance with this clause must be incorporated into the architectural drawings prior to the issue of a Construction Certificate.</p>
D3D20	Barrier climbability	CRA	<p>Balustrades must be constructed to comply with Clause D3D20.</p> <p>Where the level of the surface below is 4m or more, a balustrade or other barrier must not facilitate climbing of horizontal elements between 150mm and 760mm above the floor.</p> <p>Potentially climbable elements close to balustrades must be relocated or appropriately protected.</p>  <p>Details demonstrating compliance with this clause must be incorporated into the architectural drawings prior to the issue of a Construction Certificate.</p>
D3D21	Wire barriers	CRA	<p>Wire balustrades must be constructed to comply with Clause D3D17–D3D21 and Tables D3D21a, D3D21b and D3D21c.</p> <p>Details demonstrating compliance with this clause must be incorporated into the architectural drawings prior to the issue of a Construction Certificate.</p>
D3D22	Handrails	CRA	<p>Handrails are to be provided to at least one side of stair flights within fire isolated stairs and both side in any other case (See D3) and located not less than 865mm above the nosings of stair treads and the floor surfaces of landings.</p> <p>All internal stairways within the residential SOU's are to include single handrails as required by this Clause.</p> <p>Design verification is to be provided prior to the issue of the Construction Certificate.</p>



Part D3 – Construction of Exits

Clause	Description	Status	Comments
--------	-------------	--------	----------

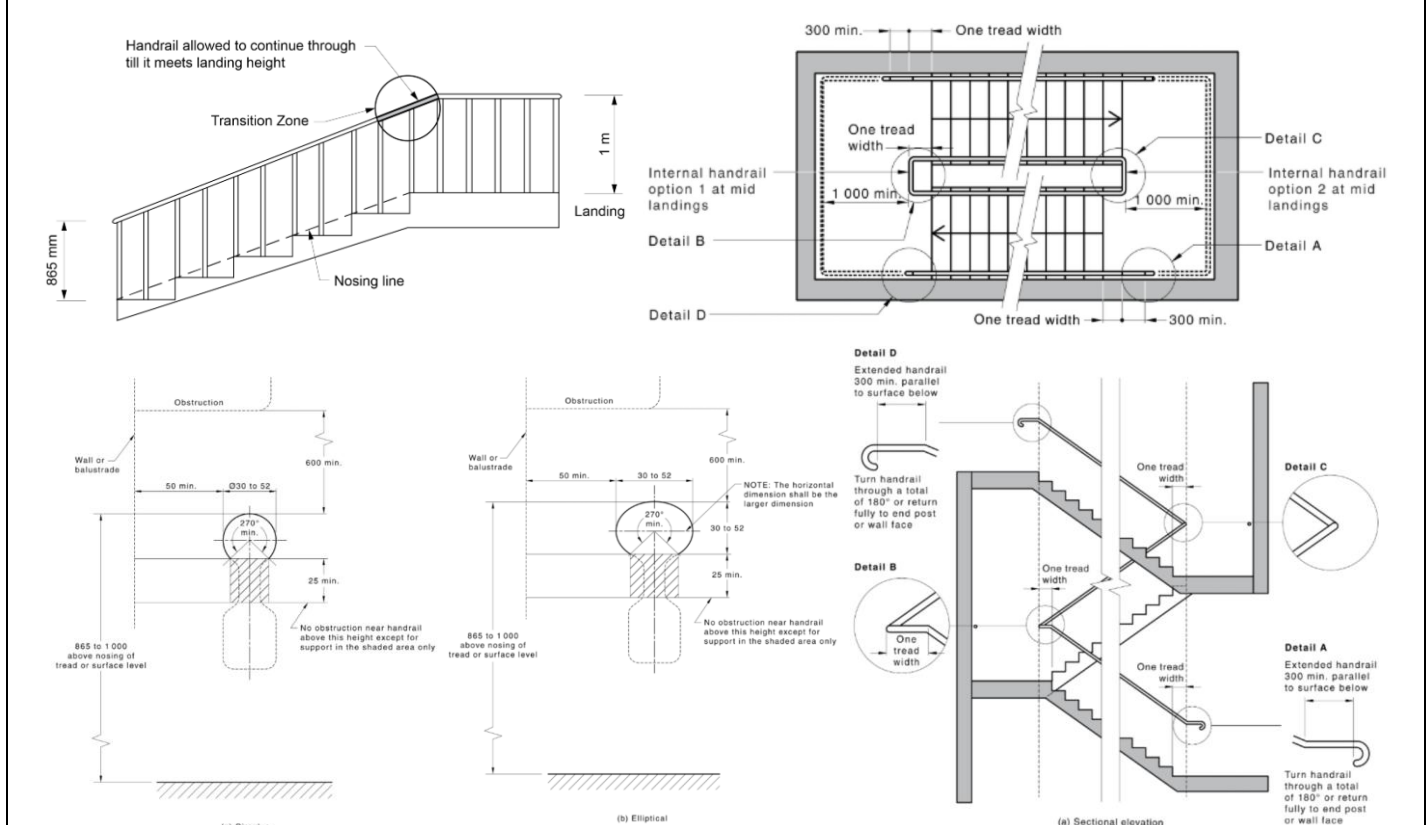

Note: Fire-isolated stairways to not require 300mm handrail extensions pictured above but require a one tread width extension at the base on the stairway to ensure the handrail travels through all landings as required. One tread width space at landings are required for exit paths from storeys required to be accessible, like entry level and those served by lift or ramp.

D3D23	Fixed platforms walkways, stairways and ladders	CRA	Fixed platforms, walkways, stairways, ladders, landings, handrails, balustrades and any tread or riser in a plant room, lift motor room or the like is to comply with AS1657.
D3D24	Doorways and doors	PS	<p>A doorway serving as a required exit or forming part of a required exit:</p> <ul style="list-style-type: none"> • must not be fitted with a revolving door; and • must not be fitted with a roller shutter or tilt-up door unless— <ul style="list-style-type: none"> ○ it serves a Class 6, 7 or 8 building or part with a floor area not more than 200 m²; and ○ the doorway is the only required exit from the building or part; and • it is held in the open position while the building or part is lawfully occupied; and • must not be fitted with a sliding door unless— <ul style="list-style-type: none"> ○ it leads directly to a road or open space; and ○ the door is able to be opened manually under a force of not more than 110 N; and • if fitted with a door which is power-operated—

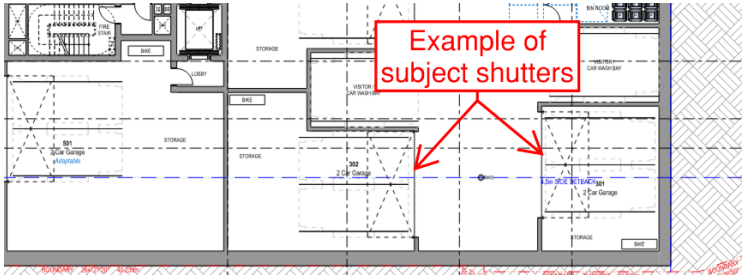
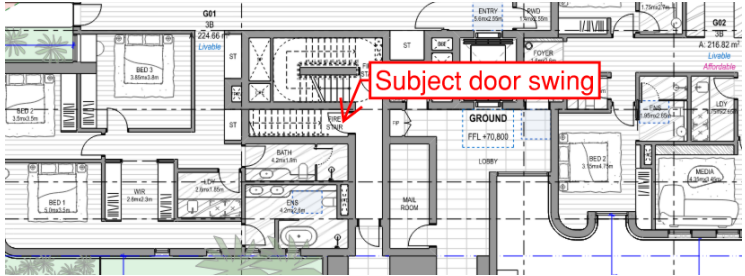
Part D3 – Construction of Exits			
Clause	Description	Status	Comments
			<ul style="list-style-type: none"> it must be able to be opened manually under a force of not more than 110 N if there is a malfunction or failure of the power source; and if it leads directly to a road or open space it must open automatically if there is a power failure to the door or on the activation of a fire or smoke alarm anywhere in the fire compartment served by the door. <p>Basement & Lower Ground Floor</p> <p>The subject shutters throughout the carpark must comply with Clauses D3D24 and D3D26 of the BCA.</p>  <p>Compliance can be achieved via undertaking a fire engineering performance solution prior to issue of the Construction Certificate.</p>
D3D25	Swinging doors	CRA	<p>A swinging door in a required exit or forming part of a required exit must not encroach more than 500 mm on the required width of a required stairway, ramp or passageway if it is likely to impede the path of travel of the people already using the exit.</p> <p>Furthermore, such a swinging door must swing in the direction of egress, unless it serves a sanitary compartment, airlock or is the only required exit serving a building part with floor area not more than 200m² and is fitting with hold open device.</p> <p>Door Swings</p> <p>The door swings pertaining to the required exits appear to comply with the requirements of this clause, with the exception of the subject door of the Ground Floor isolated stairway.</p>  <p>Compliance can be achieved via slight redesign prior to the issue of the Construction Certificate.</p>

Part D3 – Construction of Exits			
Clause	Description	Status	Comments
D3D26	Operation of latch	CRA	<p>The latch of a door in a required exit, forming part of a required exit or in the path of travel is to be readily openable without a key from the side of that faces a person seeking egress. It is to have a single downward action or pushing action and to be located between 900mm and 1100mm from the floor.</p> <p>Where the latch operation referred to above is not located on the door leaf itself, manual controls to power-operated doors must be at least 25mm wide, proud of the surrounding surface located not less than 500mm from an internal corner, and:</p> <ul style="list-style-type: none"> • for a hinged door located between 1m and 2m from the door leaf in any position; or • for a sliding door located within 2m of the doorway and clear of a surface mounted door in the open position. <p>Design verification to be provided prior to the issue of the Construction Certificate.</p>

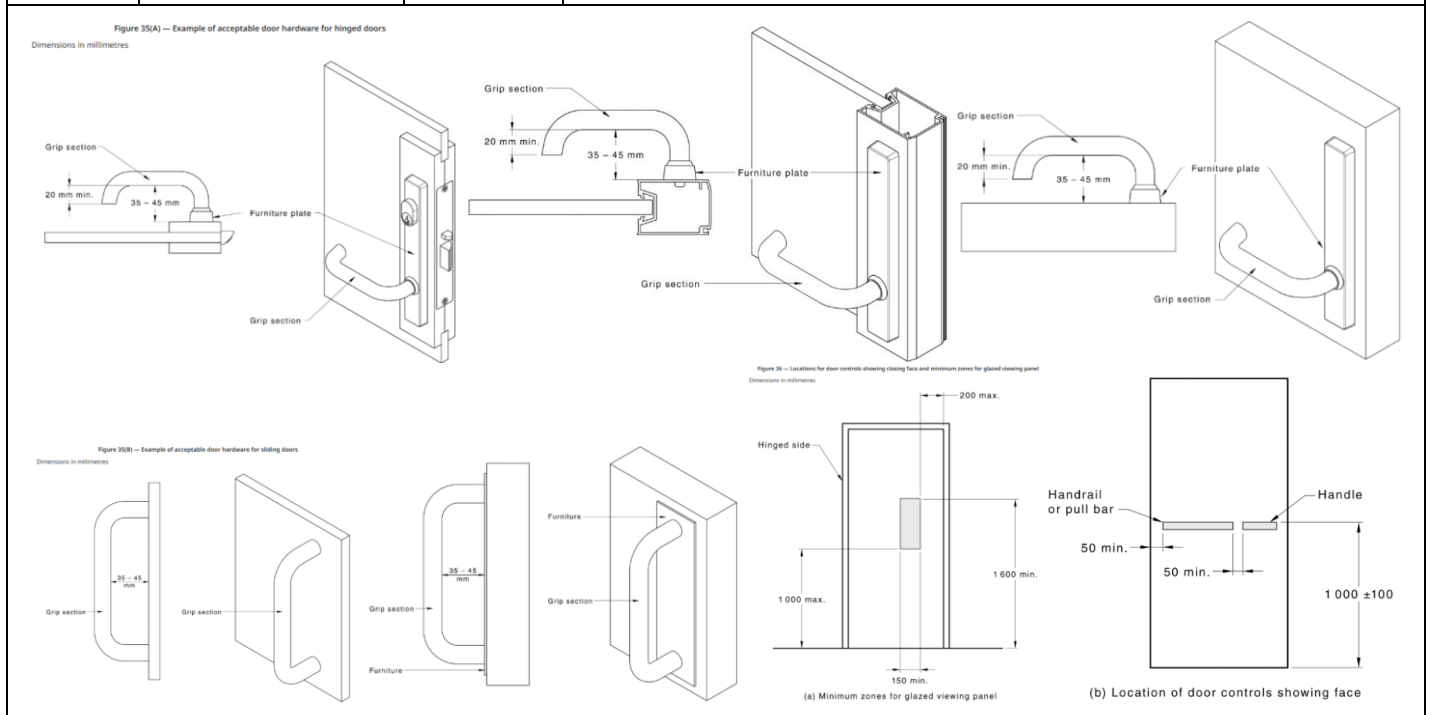

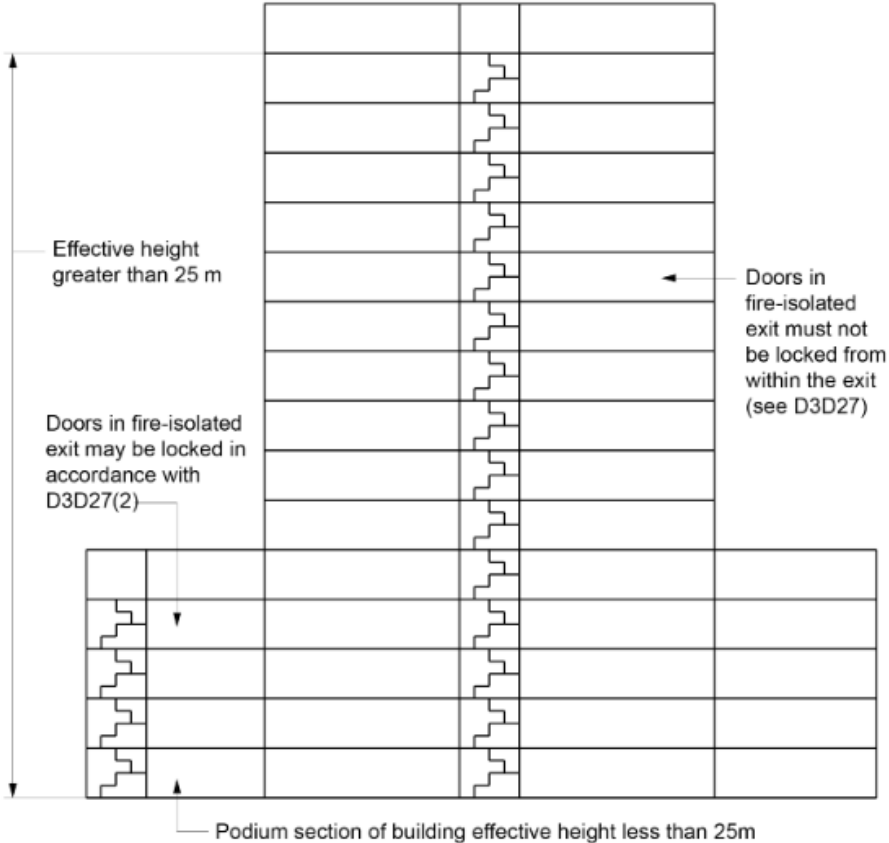
Part D3 – Construction of Exits			
Clause	Description	Status	Comments
D3D27	Re-entry from fire-isolated exits	CRA	<p>As this building exceeds an effective height of more than 25m, the doors of the fire isolated stairways must not be locked from the inside if serving any storey above an effective height of 25m.</p> <p>The above requirement does not apply to a door fitted with a fail-safe device that automatically unlocks the door upon the activation of a fire alarm and:</p> <ul style="list-style-type: none"> (i) On at least every fourth storey, the doors are not above to be locked and a sign is fixed on such doors stating that re-entry is available; or (ii) An intercommunication system, or an audible or visual alarm system, operated from within the enclosure is provided near the doors and a sign is fixed to adjacent to such doors explaining its purpose and method of operation. <p>Details demonstrating compliance with this clause must be incorporated into the architectural drawings prior to the issue of a Construction Certificate.</p>
			
D3D28	Signs on doors	Noted	<p>Fire Door and Smoke Door signage is required to be provided to all doors giving access to and egress from the fire isolated stairways.</p> <p>NOTE: Braille Exit Level Signs are to be Installed at Each Exit Also. D4D7</p>

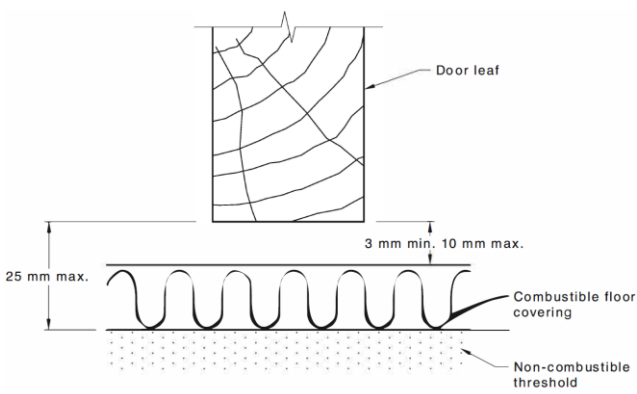
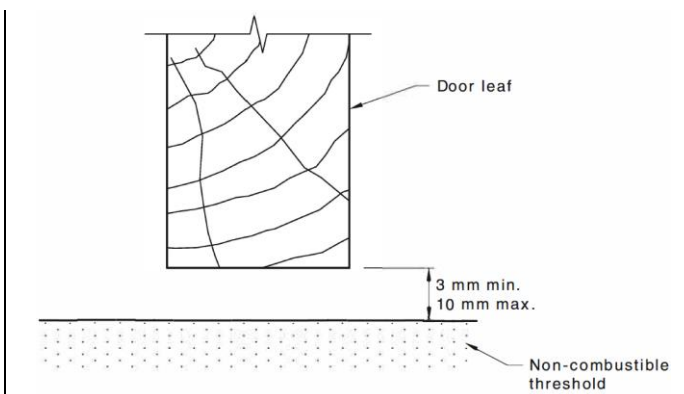
Part D3 – Construction of Exits			
Clause	Description	Status	Comments
	<p>FIRE SAFETY DOOR — DO NOT OBSTRUCT</p> <div style="border: 1px solid black; padding: 5px; margin: 5px;"> <p>FIRE SAFETY DOOR</p> </div> <div style="border: 1px solid black; padding: 5px; margin: 5px;"> <p>DO NOT OBSTRUCT</p> </div> <div style="border: 1px solid black; padding: 5px; margin: 5px;"> <p>DO NOT KEEP OPEN</p> </div> <p>FIRE SAFETY DOOR — DO NOT OBSTRUCT</p>		<p>Any Fire Door require the standard signage, “Fire Safety Door, Do not Obstruct, Do Not Keep Open etc ” along with the EP& A Notice;</p> <ul style="list-style-type: none"> – A Fire Door on an auto-closing or fire trip is to incorporate the following wording: “FIRE SAFETY DOOR—DO NOT OBSTRUCT” – A Self-Closing Fire Doors are to incorporate the following wording: “FIRE SAFETY DOOR —DO NOT OBSTRUCT —DO NOT KEEP OPEN” – For the last door discharging from a fire isolated exit, (Door opening on to open space/outside) – “FIRE SAFETY DOOR—DO NOT OBSTRUCT”. <p>Along with the required BCA signage, the EPA & A Regulations require a warning notice to be displayed in a conspicuous position adjacent to a doorway providing access to, but not within, that stairway, passageway or ramp:</p> <ul style="list-style-type: none"> – OFFENCE RELATING TO FIRE EXITS <p>It is an offence under the Environmental Planning and Assessment Act 1979:</p> <p>(a) to place anything in or near this fire exit that may obstruct persons moving to and from the exit, or</p> <p>(b) to interfere with or obstruct the operation of any fire doors, or</p> <p>(c) to remove, damage or otherwise interfere with this notice.</p>
	<p>OFFENCE RELATING TO FIRE EXITS</p> <p>It is an offence under the <i>Environmental Planning and Assessment Act 1979</i> to:</p> <ul style="list-style-type: none"> • place anything in or near this fire exit that may obstruct persons moving to and from the exit • interfere with, obstruct or impede the operation of any fire doors • remove, damage or otherwise interfere with this notice 		
	<p>All fire doors and frames are to be tagged in accordance with AS 1905.1-2015 and a complete door schedule is to be provided at the Occupation Certificate Stage.</p>		<div style="border: 1px solid black; padding: 10px;"> <p>FIRE DOORFRAME (DOOR LEAF)—TO AS 1905.1:XXXX FRL -/60/30 MANUFACTURED BY (BUSINESS NAME) DOORSET CERTIFIER—(BUSINESS/INDIVIDUAL NAME) DOOR NUMBER YEAR OF MANUFACTURE</p> </div>
	<p>Clearances under and the side of fire doors are to be in accordance with AS 1905.1-2015</p>		
	<div style="display: flex; justify-content: space-around;"> <div style="text-align: center;">  <p>(a) With a combustible floor covering</p> </div> <div style="text-align: center;">  <p>(b) Without a combustible floor covering</p> </div> </div>		



Part D3 – Construction of Exits

Clause	Description	Status	Comments
--------	-------------	--------	----------

(Company Name)
FIRE DOOR CERTIFICATE
Certificate Number 12345

Project Name:

Building Owner/
Representative:

Building Address:

The member company nominated certifies the following:

- The fire doorsets installed in this building comply with AS 1905.1:XXXX.
- The fire doorsets are labelled as required by the appropriate regulatory authorities in accordance with Australian Standard AS 1905.1:XXXX.
- A manual dealing with the fire-resistant doorsets installed in this building has been completed in accordance with AS 1905.1:XXXX.
- A paper-based copy of the manual has been provided to the building owner/representative.

Certified by: Member Company

Name of Certifier:

Signature:

Date:

Fire Resistant Doorset—Schedule of Evidence						
Project name:				Date of installation:		
Building address:						
Building owner/ representative:				Date of certification:		
Door identification number						
Door location						
Door leaf type and manufacturer						
Door facing and edging material						
Door dimensions		Width	Height	Thickness		
Frame type and manufacturer						
Frame fixing and backfill material						
Wall type and FRL						
Doorset FRL						
Doorset hardware						
Lock	Make	Model	Type	Materials on leaf	Materials on frame	FRL
Furniture	Make	Model	Type	Materials on leaf	Materials on frame	FRL
Fixtures	Make	Model	Type	Materials on leaf	Materials on frame	FRL
Fittings	Make	Model	Type	Materials on leaf	Materials on frame	FRL
Vision panel	Make	Model	Type	Materials on leaf	Materials on frame	FRL
XXXX	Make	Model	Type	Materials on leaf	Materials on frame	FRL
Test report references						
Assessment report references						
Date of final inspection		Certificate No.		Inspecting officer		Thickness
Date of Certification		Doorset Certifier's Name and (if applicable) Licence No.		Doorset Certifier's Business Name		
Operating and maintenance information						
Doorframe						
Doorset						
Lock						
Furniture						
Fixtures						
Fittings						
Vision panel						



Part D3 – Construction of Exits			
Clause	Description	Status	Comments
D3D29	Protection of openable windows	CRA	<p>All window openings throughout the development must be provided with protection, if the floor below the window is 2m or more above the surface beneath in a Class 2 building.</p> <p>Where the lowest level of the window opening is less than 1.7m above the floor, the operable portion of the window must be protected with a device capable of restricting the window opening or a screen with secure fittings.</p> <p>A device or screen must:</p> <ul style="list-style-type: none">• Not permit a 125mm sphere to pass through the window opening or screen;• Resist an outward horizontal action of 250N against the window restraining device or screen protecting the opening; and• Have a child restraint release mechanism if the screen or device is able to be removed, unlocked or overridden. <p>A barrier with a height not less than 865mm above the floor is required to an openable window in addition to window protection, when a child resistant release mechanism is required and where the floor below the window is 4m or more above the surface beneath if the window is not provided with protection. The barrier must not permit a 125mm sphere to pass through it and must not contain any horizontal or near horizontal elements between 150mm and 760mm above the floor that facilitate climbing.</p> <p>Details demonstrating compliance with this clause must be incorporated into the architectural drawings prior to the issue of a Construction Certificate.</p>
D3D30	Timber stairways: Concession	N / A	
NSW D3D31	Doors of travel in an entertainment venue	N / A	



Part D4 – Access for People with Disabilities			
Clause	Description	Status	Comments
D4D1	Deemed-to-Satisfy Provisions	Note	<p>Disability (Access to Premises — Buildings) Standards 2010 is to be read in conjunction with the BCA.</p> <p>Compliance with the Access Codes appears to be achieved.</p>
D4D2	General Building Access Requirements	CRA	<p>Buildings and parts of buildings must be accessible as required by D4D2, unless exempted by D4D5.</p> <p>Compliance with Part D4 of the BCA is applicable to this building.</p> <p>All common areas are also to facilitate access in accordance with AS1428.1.</p> <p>A continuous accessible path of travel (CAPT) is required from a pedestrian entrance to at least 1 floor containing sole-occupancy units and to the entrance doorway of each sole-occupancy unit located on that level and to and within not less than 1 of each type of room or space for use in common by the residents, including a cooking facility, sauna, gymnasium, swimming pool, common laundry, games room, individual shop, eating area, or the like.</p> <p>Where a ramp complying with AS 1428.1 or a passenger lift is installed, a CAPT is required to the entrance doorway of each sole-occupancy unit, as well as to and within one of each type of room or space for use in common by the residents, located on the levels served by the lift or ramp.</p> <p>All common areas throughout the building are to be accessible in accordance with AS1428.1.</p> <p>Access into the ground and first floors is required to be 100% wheelchair accessible, with the exception of areas exempt by Clause D4D5 of the BCA.</p> <p>Areas required to be accessible</p> <p>Access to the building's Basement 1 bin room, Lower Ground 2 wellness centre and the like, Lower Ground pool and common areas, and Seventh Floor common areas are required to be accessible and access appears to be provided.</p> <p>Abutments of surfaces are to comply with Section 4 of AS1428.1-2021.</p> <p>Final design details of wheelchair access to this part are to be provided at the final Construction Certificate stage.</p>

Architects/Designers Note: AS1428.1-2021 is very detailed, please ensure that your design has been checked and rechecked as to full compliance .i.e.:

- All doors are to be a minimum of a clear opening width of not less than 850 mm and the required circulation spaces around doors to be accessible in accordance with AS 1428.1.
- Door hardware is to a 'D' style handle to provide adequate grip for people with hand impairments.
- Unless the door is a fire door or smoke door, maximum 20N force permitted to open, hold open and close a door.
- Walkways, corridors also must be compliant for dead areas, turning spaces, passing spaces and splayed corners.
- Doors and doorways need to have 30% luminance contrasting to distinguish door locations,

Part D4 – Access for People with Disabilities

Clause	Description	Status	Comments
	<p>- All full-height glazing along continuous accessible paths of travel need a 30% luminance contrasting strip, The contrasting line shall be not less than 75 mm wide and shall extend across the full width of the glazing panel. The lower edge of the contrasting line shall be located between 900 mm and 1000 mm above the plane of the finished floor level. Any contrasting line on the glazing shall provide a minimum of 30% luminance contrast when viewed against the floor surface or surfaces within 2 m of the glazing on the opposite side.</p> <p>- All stairs excluding the fire isolated stair are to incorporate the required double handrail, downturns, solid treads, colour contrast nosing strips and TGSIs.</p> <p>Floor surfaces and junction points are all smooth and comply with slip resistant levels.</p>		

Door Circulation Spaces

All circulation spaces to SOU doors and doorways through common areas are confirmed and doorways leading to areas required to be accessible appear to meet the set dimensions under AS1428.1-2021.

Design verification to be provided prior to the issue of the Construction Certificate.

Figure 31 – Circulation spaces at doorways with swinging doors

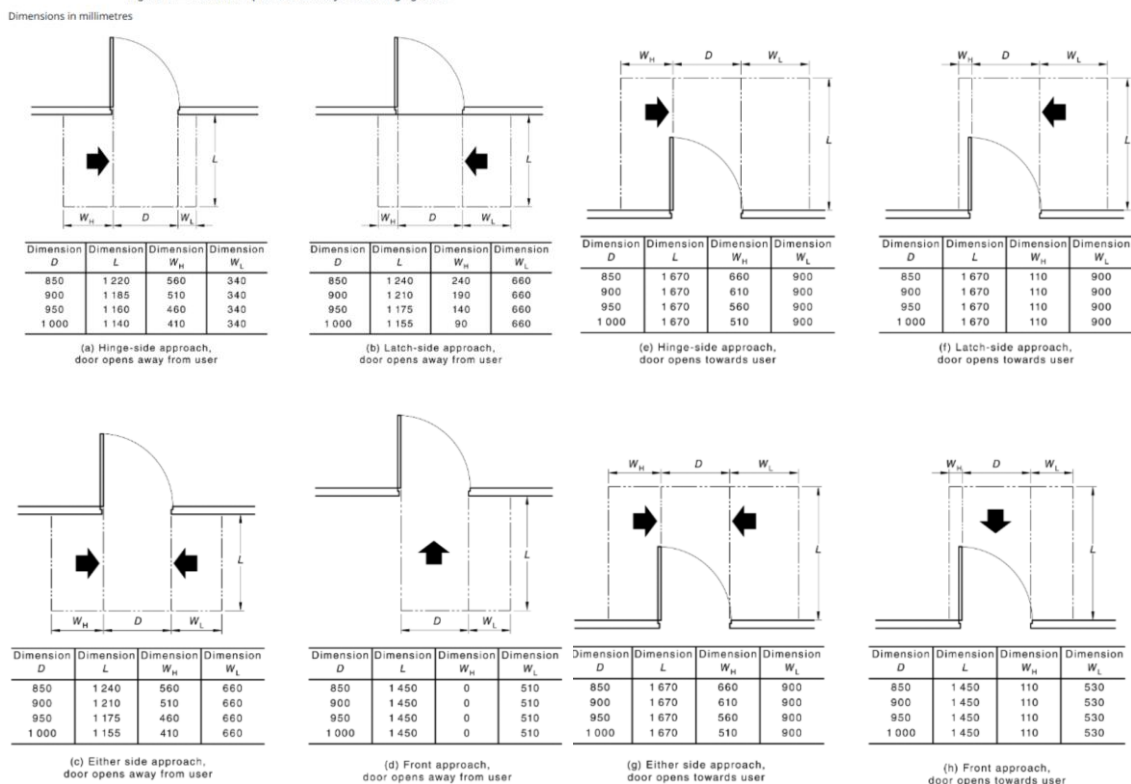
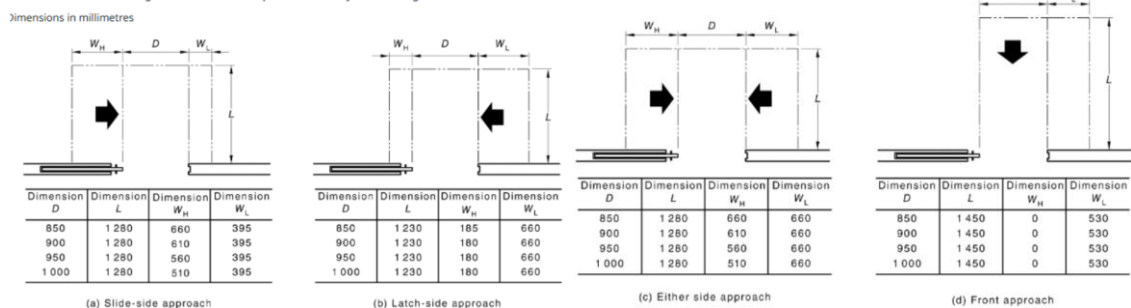

Figure 32 – Circulation spaces at doorways with sliding doors



Part D4 – Access for People with Disabilities			
Clause	Description	Status	Comments
D4D3	Access to Buildings	CRA	<p>An accessway/s has been provided from Principal Pedestrian Entry (PPE) areas.</p> <p>The use of a platform lift in accordance with AS 1735.14 Low-rise platform lift is allowed for this building and is limited to 1m.</p> <p>The residential parts of the building are deemed to have only one entry, the fire isolated exits are for egress purposes only.</p> <p>All doors are to be a minimum of a clear opening width of not less than 850 mm and the required circulation spaces around doors to be accessible in accordance with AS 1428.1 including SOU doors to storey serviced via a lift.</p> <p>All stairs excluding fire isolated stair are to incorporate the required double handrail, downturns, colour contrast nosing strips and TGSI's.</p> <p>Nosing to stairs within the fire isolated passage are to have a colour contrasting strip.</p> <p>Final design details of wheelchair access to this part are to be provided at the final Construction Certificate stage.</p>
D4D4	Parts of Buildings to be accessible	CRA	<p>Final details to be provided detailing floor services and materials are to be provided at the Construction Certificate stage or noted on the plans.</p>

Passing Spaces

Passing spaces are required to be accessible in accordance with AS 1428.1-2021.

Passing Spaces for Wheelchairs are to be provided in corridors longer than 20m.

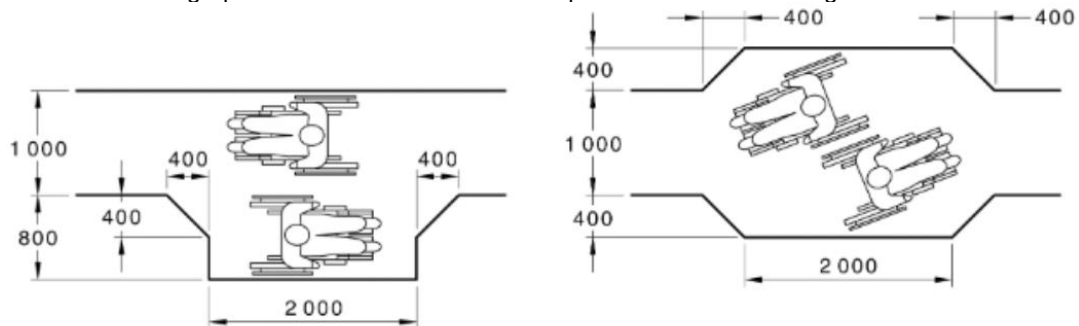

All dimensions are minimum

Turning Spaces, Landings & Dead End Zones

Turning spaces and dead end zones throughout the building appear to be provided within accessways required to be accessible in accordance with AS 1428.1-2021.

The intermediate landing of the ramp serving the pool area on Lower Ground 1 requires review.

Compliance can be achieved via slight redesign prior to the issue of the Construction Certificate.

Part D4 – Access for People with Disabilities

Clause	Description	Status	Comments
--------	-------------	--------	----------

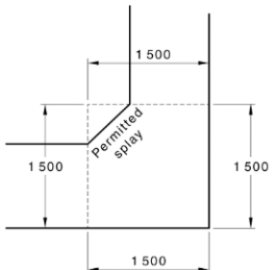
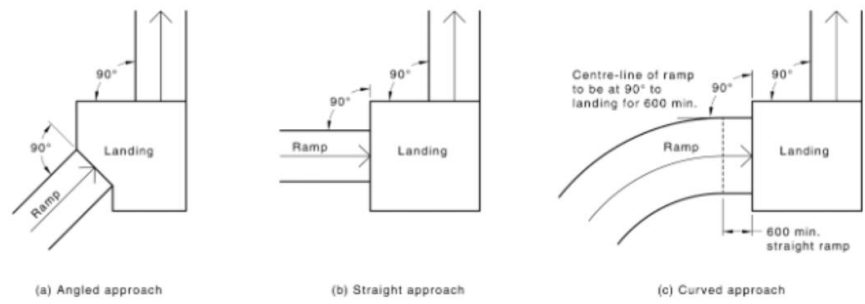

Turn 90° in path of travel
Corridor less than 1 500 mm wide
requires widening at turn

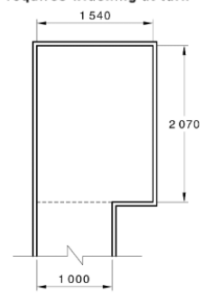

(a) Space required in corridor

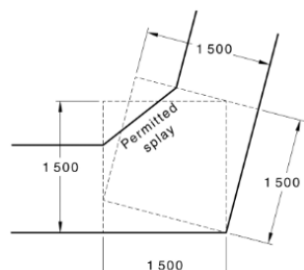

Turn 75° in path of travel
Corridor less than 1 500 mm wide
requires widening at turn

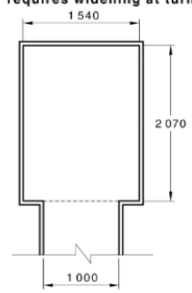

(b) Space required in corridor

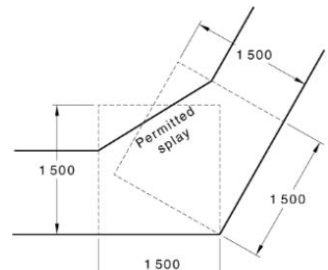

Turn 60° in path of travel
Corridor less than 1 500 mm wide
requires widening at turn

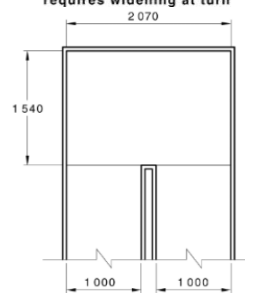

(c) Space required at ramp landing

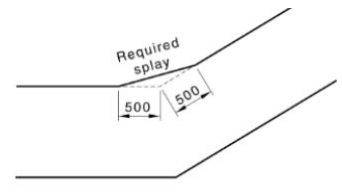

Turn 30° to < 60° in path of travel
less than 1 200 mm wide

All dimensions are minimum

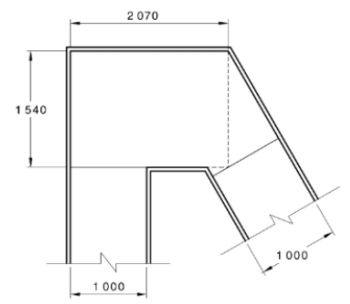

(d) Space required at ramp landing

Figure 25(A) — Ramps and landings — With no change in direction

Figure 25(B) — Ramps and landings — 90° landing — Internal

Dimensions in millimetres

Dimensions in millimetres

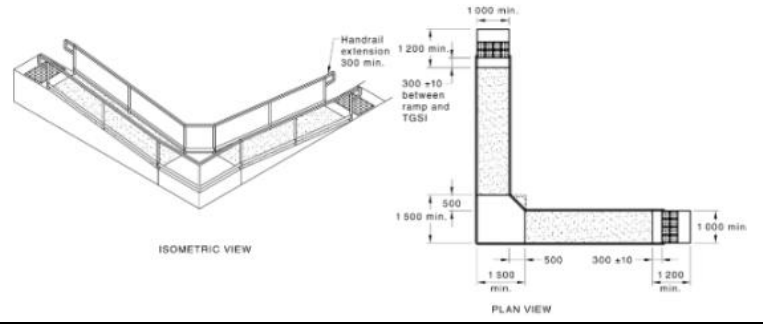
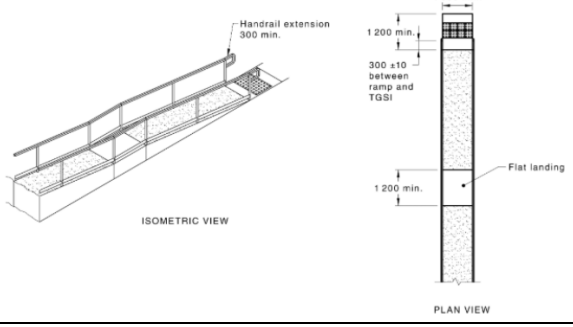



Part D4 – Access for People with Disabilities

Clause	Description	Status	Comments
--------	-------------	--------	----------

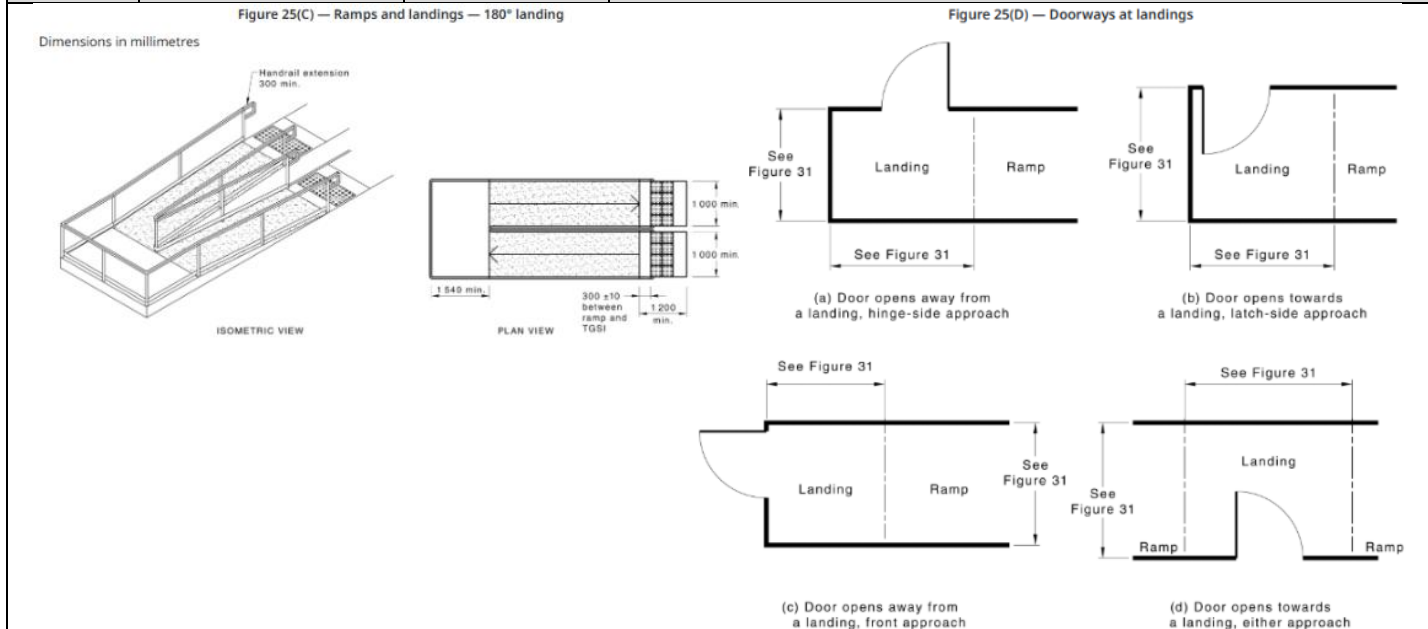

All finished floor surfaces are to be trip free, the following details demonstrate the tolerance level for floor finishes.

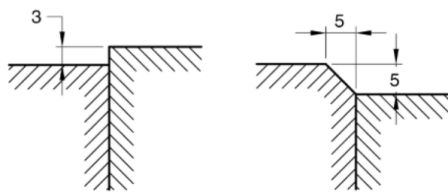

(a) Change in level

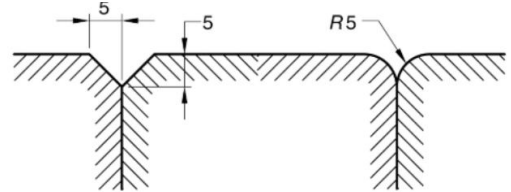

(b) Continuous paving units — flush-jointed with level surfaces

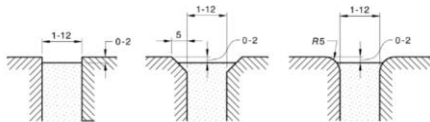

(a) Continuous paving units — Level surface

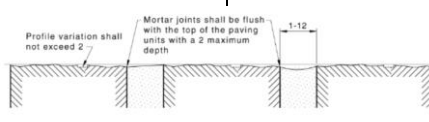

(b) Continuous paving units — Irregular surfaces

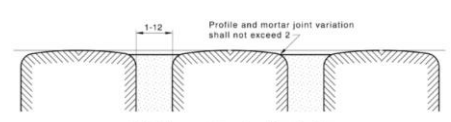

(c) Continuous paving units — Domed surfaces



(a) Gap spacing for continuous timber and composite decking
* Gaps may be increased to 10 mm in high rainfall areas for exposed installations and boards exceeding 150 mm width

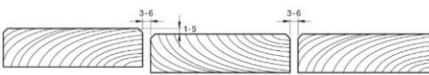

(b) Single incidence of change in level on timber and composite decking

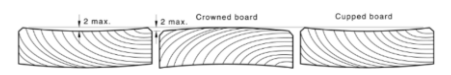

(c) Uneven surface tolerances for continuous timber and composite decking

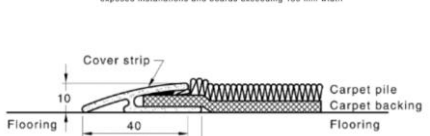

(a) Optional section A

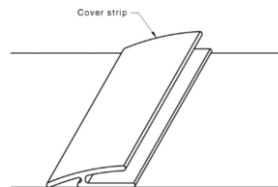

(b) View of optional section A

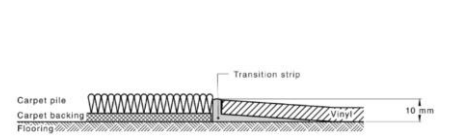

(c) Optional section B

Handrail Extensions

Any non-fire isolated stairways or ramps are required to include double handrails which extend 300mm from the top of the stairway or ramp and 600mm from the base in accordance with AS 1428.1-2021.

Design verification to be provided prior to the issue of the Construction Certificate.



Part D4 – Access for People with Disabilities

Clause	Description	Status	Comments
--------	-------------	--------	----------

Figure 15(A) — Ramp handrails — Examples of handrail terminations

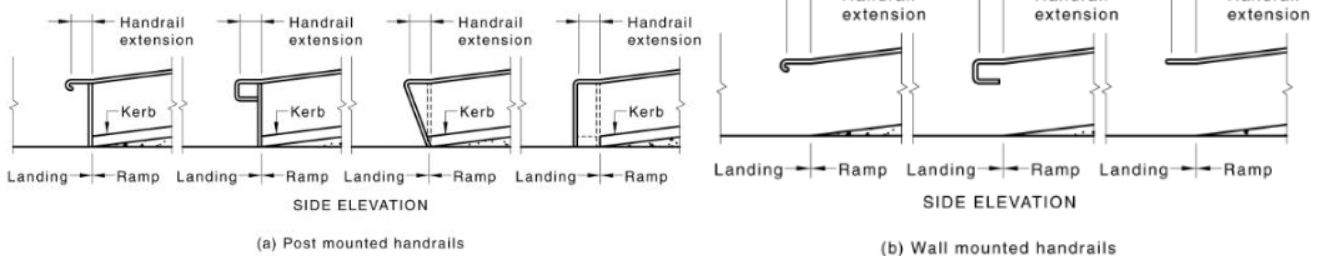

Figure 26(C) — Stair handrails — Examples of handrail terminations

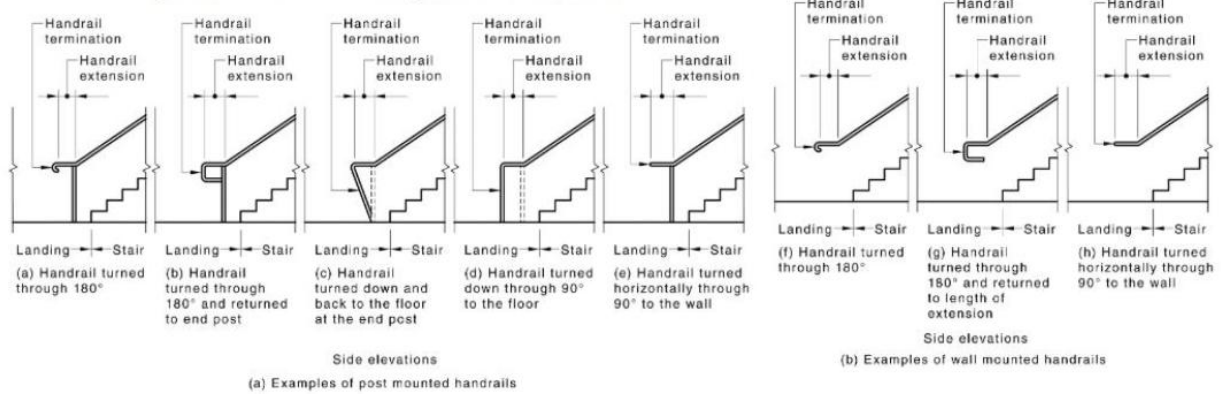

Figure 15(B) — Ramp handrails — Detail for handrails terminated by turning horizontally through 90° to the wall
Dimensions in millimetres

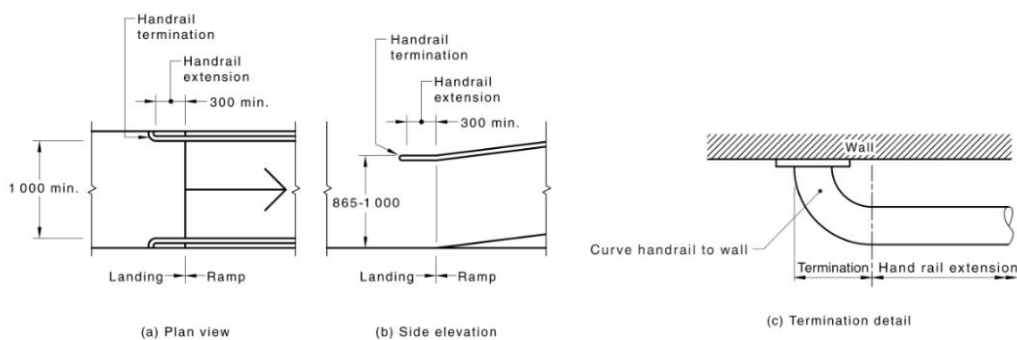

Figure 26(D) — Example of detail for handrails terminated by turning horizontally through 90° to the wall
Dimensions in millimetres

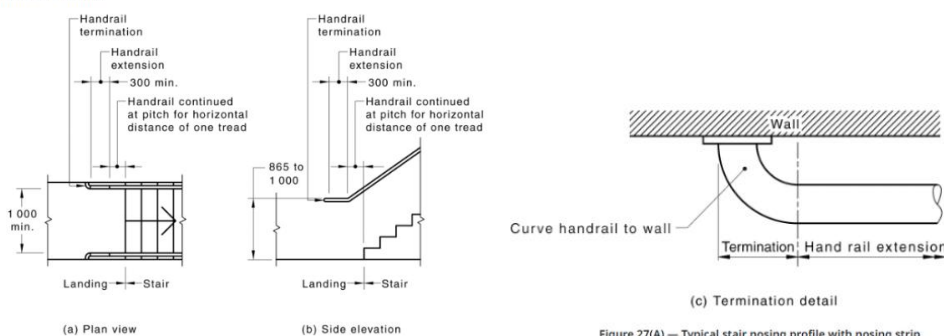

Figure 27(A) — Typical stair nosing profile with nosing strip

Part D4 – Access for People with Disabilities

Clause	Description	Status	Comments
--------	-------------	--------	----------

Tactile or TGSIs are to be installed correctly to all stairs and ramps. These TGSIs are to be re-installed to the correct distance from the nosing and the height from the FFL.

The floor surface is to be cut to allow the TGS mat to be fixed to the slab and provide the correct height.

Stairways and Ramps

Any non-fire isolated stairways or ramps are required to include double handrails and tactiles in accordance with AS 1428.1-2021.

Design verification to be provided prior to the issue of the Construction Certificate.

Figure 16 — Location of ramp at a boundary to prevent protrusion of handrails and tactile ground surface indicators (TGSIs) into a transverse path of travel

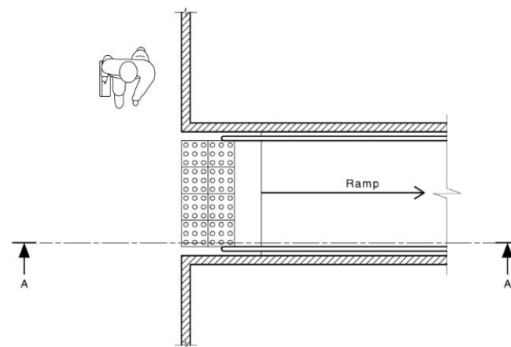
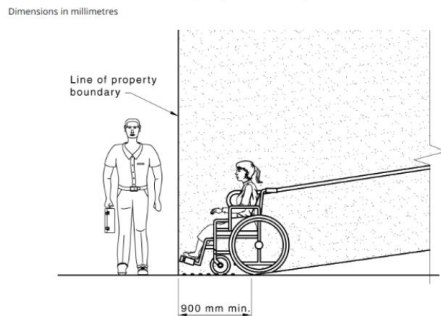

Figure 17 — Location of ramp to prevent protrusion of handrails into a transverse path of travel other than at boundaries

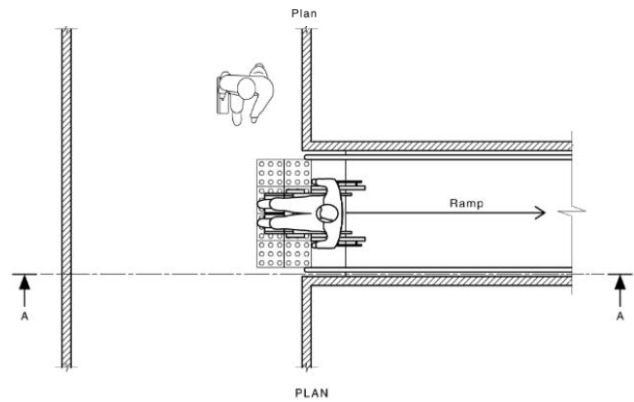
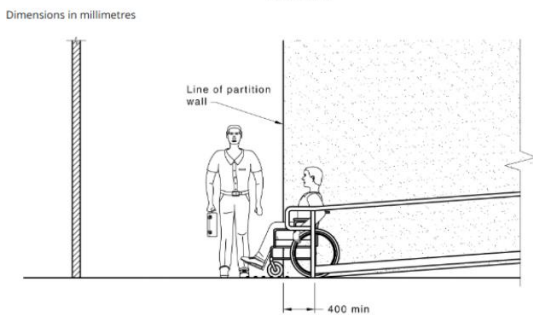
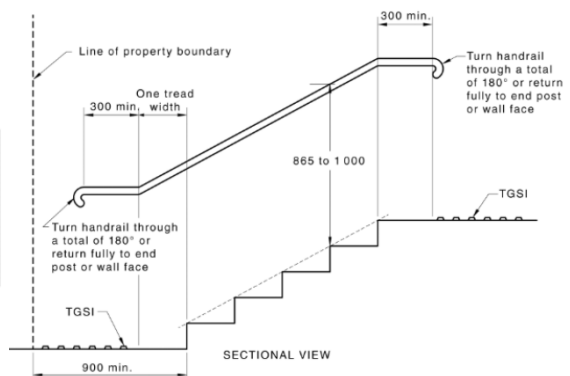
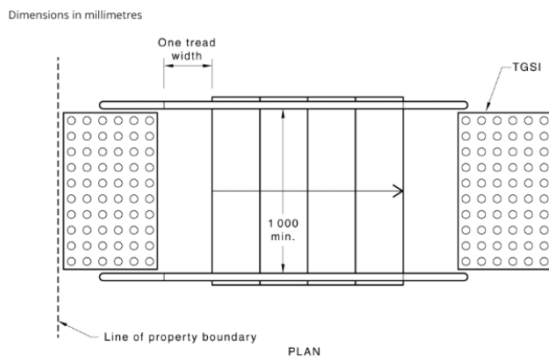

Figure 26(A) — Stairway location and handrail extensions at boundary





Part D4 – Access for People with Disabilities

Clause	Description	Status	Comments
--------	-------------	--------	----------

Figure 26(B) — Stairway location and handrail extensions at end of stairway other than at line of boundary

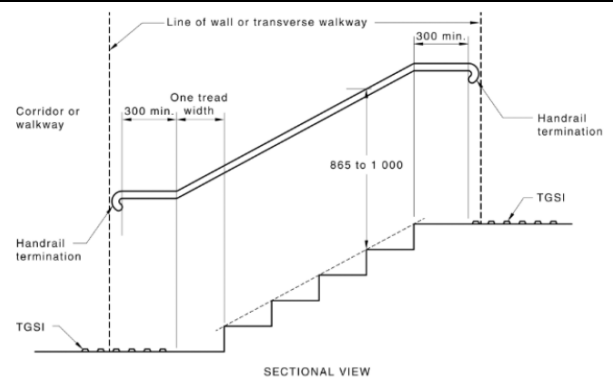
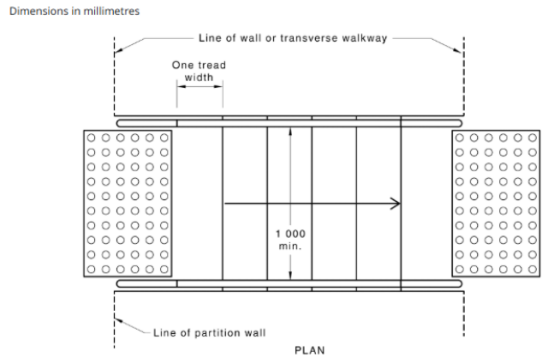

Figure 27(A) — Typical stair nosing profile with nosing strip

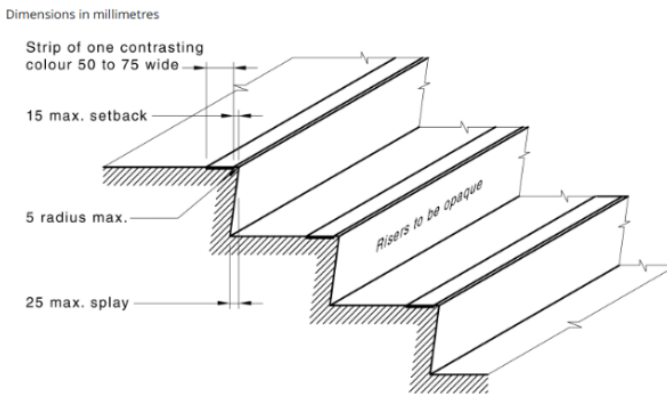
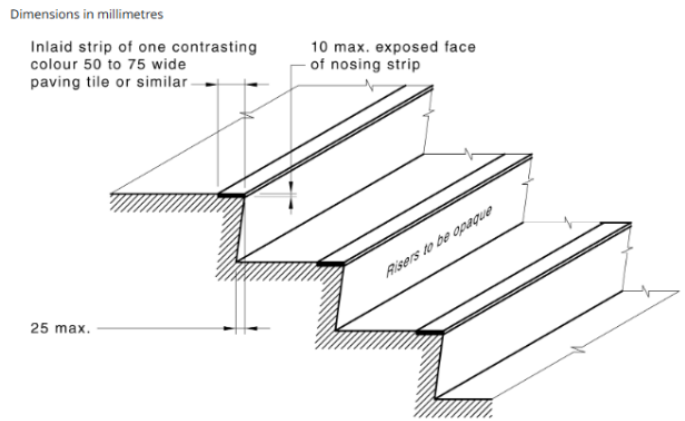
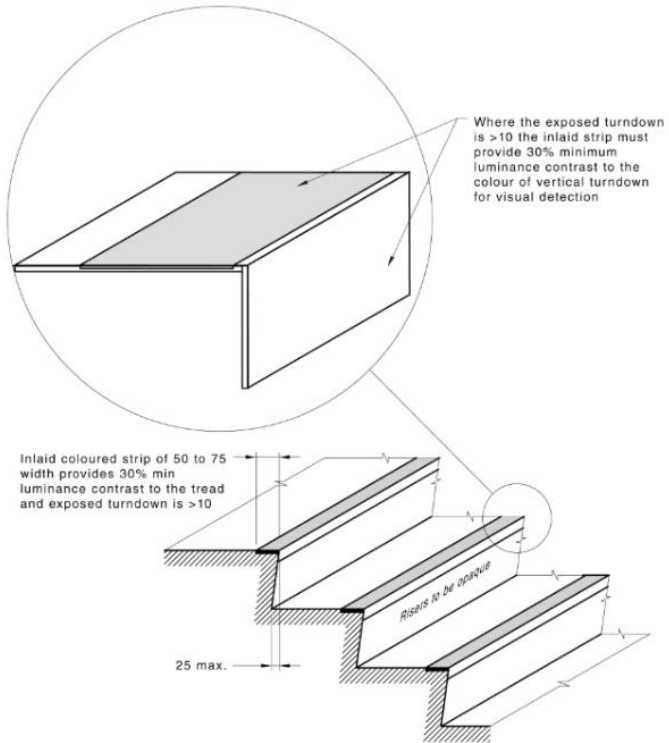

Figure 27(B) — Typical stair nosing profile with exposed nosing strip



NOTE A chamfered nosing 5 x 5 mm may be used.

Figure 27(C) — Typical stair nosing profile

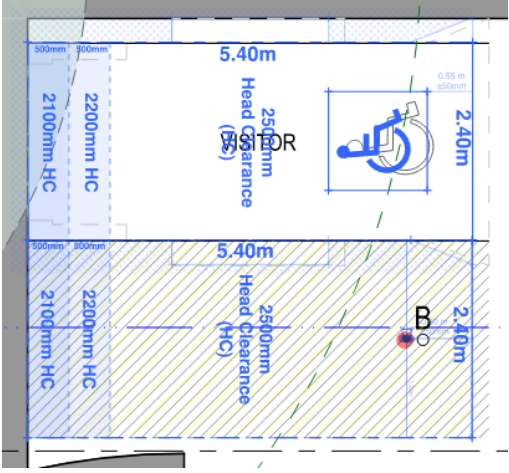

Part D4 – Access for People with Disabilities			
Clause	Description	Status	Comments
D4D6	Accessible Carparking	CRA	<p>Car-parking spaces have been provided to the building which are ancillary to the use.</p> <p>No accessible carparking spaces are required to be provided to the Class 2 residential SOUs under D4D6. However Council DCP for adaptable Units may require additional spaces.</p> <p>The car space still must comply with the space requirements of AS2890.6 form person with a disability.</p> <p>Design verification to be provided prior to the issue of the Construction Certificate.</p>
			<p>As this building is to incorporate adaptable units, usually each unit is to be allocated a car space being in accordance with AS2890.6 or as per AS4299-1995.</p> <p>Bollards</p> <p>Shared zones are to be provided with a bollard 800mm ±50mm from the front of the space and equidistant from either side of the space.</p> <p>Compliance can be achieved via slight redesign prior to the issue of the Construction Certificate.</p> <p>Shared Zone</p> <p>The shared zone must be designated (shaded) as required by D4D6 and AS 2890.6-2009.</p> <p>CAR PARKING</p> <p>General Private car parking spaces shall be large enough to enable a person with a wheelchair to get in and out of both the car and the parking space. A car parking space width of 3.8 m minimum is necessary to enable a driver to alight, open the passenger side door, and assist a person with a disability into a wheelchair, or for a side-loading ramp. A 3.8 m, minimum width is also required for a driver with a disability to unload a wheelchair and to alight. A roof to the car parking space is desirable.</p> <p>NOTE: If it is required to unload the wheelchair within the garage, an internal vertical clearance of 2.5 m is necessary to operate a car roof wheelchair unit.</p> <p>Garages and carports Garages and carports shall have minimum internal dimensions of 6.0 m × 3.8 m. A 2.5 m internal vertical clearance is desirable. A garage may be reduced if a hard surfaced level outside space of minimum dimensions 5.4 m × 3.8 m is provided as a sheltered carpark, or can be provided in the future. Provision for a power operated roller door is desirable.</p> <p>NOTE: A level surface includes surfaces with a gradient of up to 1:40.</p>

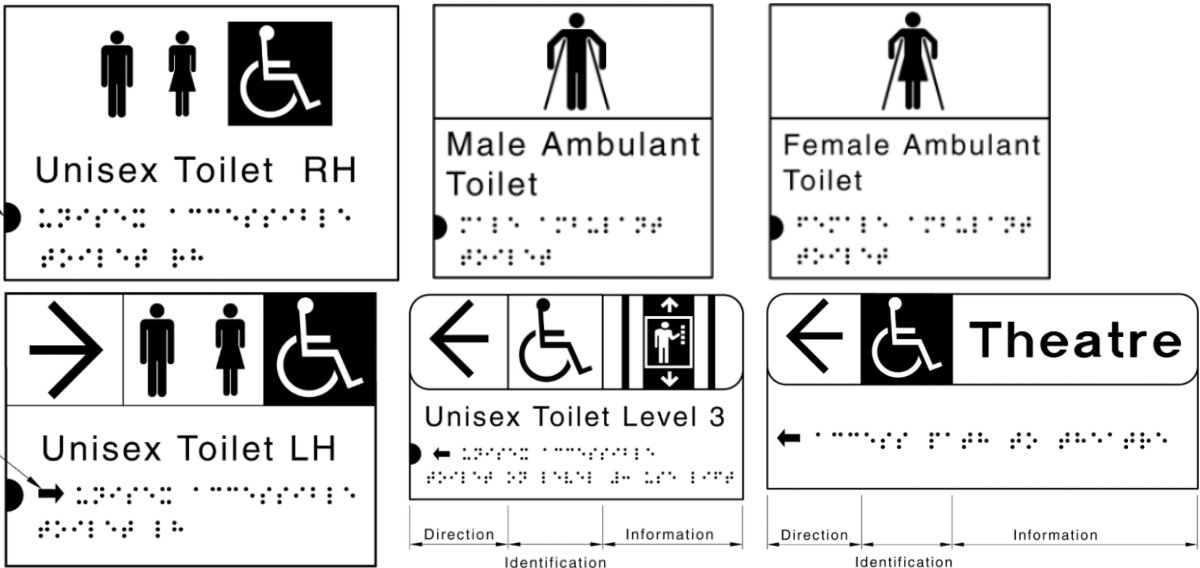
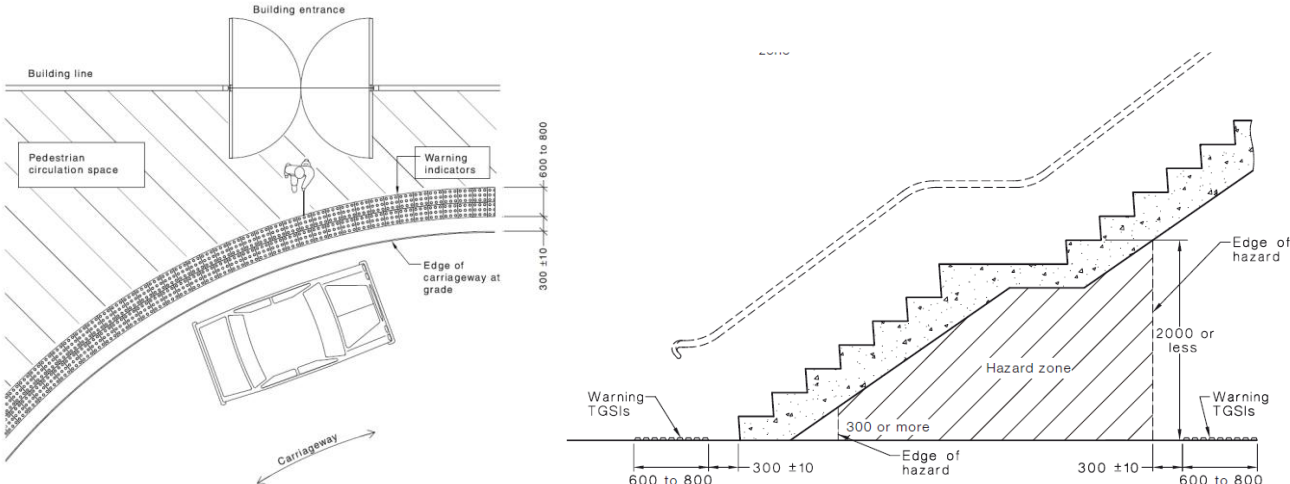

Part D4 – Access for People with Disabilities			
Clause	Description	Status	Comments
	<p>Each dedicated space shall be identified by means of a white symbol of access in accordance with AS 1428.1 between 800 mm and 1000 mm high placed on a blue rectangle with no side more than 1200 mm, placed as a pavement marking in the centre of the space between 500 mm and 600 mm from its entry point as illustrated.</p>		
D4D7	Signage	Noted	<p>In a building required to be accessible –</p> <p>Braille and tactile signage complying with Specification 15 and incorporating the international symbol of access or deafness, as appropriate, in accordance with AS1428.1 must identify each –</p> <ul style="list-style-type: none"> – Sanitary facility, – Ambulant toilet facility, – Any required accessible carparking space, – Where needed, directional signage to any Carparking space, sanitary facility, or accessible adult change facility. – At Each 'Exit' and which 'Level' an occupant is at also needs to be in Braille. <p>Where a bank of sanitary facilities is not provided with an accessible unisex sanitary facility, directional signage incorporating the international symbol of access in accordance with AS 1428.1 must be placed at the location of the sanitary facilities that are not</p>

Part D4 – Access for People with Disabilities			
Clause	Description	Status	Comments
			<p>accessible, to direct a person to the location of the nearest accessible unisex sanitary facility.</p> <p>Design verification to be provided prior to the issue of the Construction Certificate.</p>
	 <p>Braille indicator</p> <p>Wayfinding arrow</p>		
	 <p>Building line</p> <p>Building entrance</p> <p>Pedestrian circulation space</p> <p>Warning indicators</p> <p>Edge of carriageway at grade</p> <p>Carriageway</p> <p>Warning TGSIs</p> <p>Edge of hazard</p> <p>Hazard zone</p> <p>Edge of hazard</p>		

Part D4 – Access for People with Disabilities

Clause	Description	Status	Comments
D4D8	Hearing Augmentation	N / A	
D4D9	Tactile Indicators	CRA	<p>For a building required to be accessible, tactile ground surface indicators must be provided to warn people who are blind or have a vision impairment in accordance with this clause. I.e.:</p> <ul style="list-style-type: none"> - A stairway, other than a fire-isolated stairway, - An escalator, - A passenger conveyor or moving walk, - A ramp other than a fire-isolated ramp, step ramp, kerb ramp or swimming pool ramp, - In the absence of a suitable barrier an overhead obstruction less than 2m above floor level, other than a doorway. <p>Tactile ground surface indicators required by (a) must comply with sections 1 and 2 of AS/NZS 1428.4.1</p> <p>Design verification to be provided prior to the issue of the Construction Certificate.</p>

There are three (3) distinct types of TGSIs, these each need to be assessed as to the most appropriate based on the surface it is to be applied and lighting conditions. AS1428.4.1 – 2009 clearly provides installation requirements.



30% contrast to surface



45% Contrast to Surface



60% Contrast to Surface

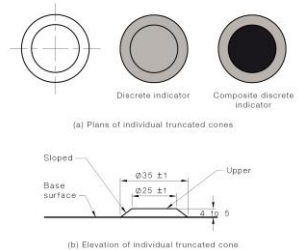



Part D4 – Access for People with Disabilities			
Clause	Description	Status	Comments
<p>As Occupants may pass under stairs, they must be obstructed or have TGSI's installed to warn of overhead obstructions.</p> <div style="display: flex; justify-content: space-between;"> <div style="width: 45%;"> <p style="text-align: center;">SECTIONAL VIEW</p> <p style="text-align: center;">DIMENSIONS IN MILLIMETRES</p> <p style="text-align: center;">FIGURE 26(A) STAIRWAY LOCATION AND HANDRAIL EXTENSIONS AT BOUNDARY</p> </div> <div style="width: 45%;"> </div> </div>			
D4D10	Wheelchair Seating Spaces in Class 9b Assembly Buildings	N / A	
D4D11	Swimming Pools	CRA	<p>Not less than 1 means of accessible water entry/exit in accordance with Specification 16 must be provided for each swimming pool required by D4D2 to be accessible.</p> <p>An accessible entry/exit must be by means of—</p> <ul style="list-style-type: none"> ○ a fixed or movable ramp and an aquatic wheelchair; or ○ a zero-depth entry at a maximum gradient of 1:14 and an aquatic wheelchair; or ○ a platform swimming pool lift and an aquatic wheelchair; or ○ a sling-style swimming pool lift. <p>Where a swimming pool has a perimeter of more than 70 m in length, at least one accessible water entry/exit must be provided by a means other than a sling-style swimming pool lift.</p> <p>Latching devices on gates and doors forming part of a swimming pool safety barrier need not comply with AS 1428.1.</p> <p>Design verification to be provided prior to the issue of the Construction Certificate.</p>
D4D12	Ramps	CRA	<p>On an accessway –</p> <p>(a) A series of connected ramps must not have a combined vertical rise of more than 3.6m; and</p> <p>(b) A landing for a step ramp must not overlap a landing for another step ramp or ramp.</p>



Part D4 – Access for People with Disabilities			
Clause	Description	Status	Comments
D4D13	Glazing on an Accessway	CRA	<p>On an accessway, where there is no chair rail, handrail or transom, all frameless or fully glazed doors, sidelights, and any glazing capable of being mistaken for a doorway or opening, must be clearly marked in accordance with AS 1428.1.</p> <p>Design verification to be provided prior to the issue of the Construction Certificate.</p>

SECTION E – SERVICES AND EQUIPMENT
Part E1 – Fire Fighting Equipment

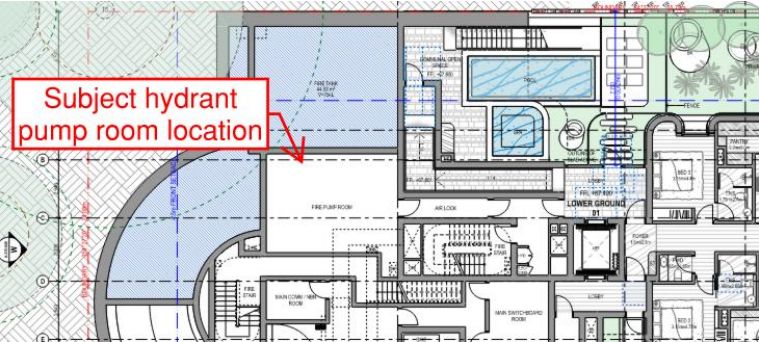
Clause	Description	Status	Comments
E1D1	Deemed-to-Satisfy Provisions	-	-
E1D2	Fire Hydrants	CRA	<p>Fire Hydrant Coverage is required throughout the whole building in accordance with AS 2419.1.</p> <p>Location of fire hydrant booster system appears to be within 10m of the building surrounded by a fire rated construction extending less than 2m either side of the booster outlets as required by AS2419.1.</p> <p>The subject hydrant pump room in Lower Ground 1 does not depict the dimensions of the hydrant outlet and so accurate measurements for width cannot be provided.</p> <p>PVC pipes, which are not essential services, may be located within the hydrant pump room due to the units located in the floor above.</p> <div style="text-align: center;">  </div> <p>Compliance can be achieved via slight redesign prior to the issue of the Construction Certificate.</p> <p>Final plans and a design certificate from a qualified hydraulic engineer prior to the issue of a Construction Certificate.</p> <p><i>Please note: If variations from AS2419.1 are required, a Clause 188 approval may be required to be submitted to the NSW Fire Brigade for approval, please allocate time for this process if required.</i></p>

AS2419.1:2021

3.5.3 Location

3.5.3.1 General

External fire hydrants shall be installed as follows:

(a) Each external fire hydrant shall be located in a position that provides pedestrian access to the building.

(b) Each external fire hydrant shall be located in a position —

- i. not less than 10 m from the building or fire compartment it is protecting, unless the fire hydrant is protected in accordance with Clause 3,5.5;
- ii. not less than 10 m from any high voltage 1main electrical distribution equipment such as transformers and distribution boards;



Part E1 – Fire Fighting Equipment			
Clause	Description	Status	Comments
	<ul style="list-style-type: none">iii. not less than 10m from any Electric Vehicle Charging Station regardless of voltage unless protected by a wall or other construction having an FRL as defined in Clause 3.5.5.2;iv. not less than 10 m from a stored quantity of dangerous goods (e.g. LPG, petroleum, propane);v. not less than 10 m from external combustible storage (e.g. palletized combustible storage items); andvi. not less than 3 m from the vent terminal of any gas assembly or gas measurement system. <p>NOTE For gas assembly and gas measurement systems, refer to AS/NZS 5601.1.</p>		
(c)	An external fire hydrant shall have an area extending 500mm each side of the fire hydrant hand wheel and 1m in front of the fire hydrant that is free from obstruction.		
(d)	Where a fire hydrant is installed in a car park, or in an area where vehicles manoeuvre or park and the vehicles are able to come not more than 1m from the fire hydrant, bollards shall be provided to protect the fire hydrant and allow for the connection and laying of fire hose.		
3.5.5 Protection of fire hydrants			
3.5.5.1 Sprinkler-protected buildings			
The requirements of Clause 3.5.5.2 do not apply to external fire hydrants located not more than 10m from the building, provided the building is sprinkler-protected by a sprinkler system or a combination of sprinkler systems confirming to AS 2118.1, AS 2118.4, AS 2188.6, FPAA101D or FPAA101H.			
3.5.5.1 Sprinkler-protected buildings			
Where external fire hydrants are located not more than 10m from a non-sprinkler-protected building, that shall be protected —			
(a)	if located within or affixed to the external wall of a building by walls, floors and/or ceilings, as applicable, that —		
	<ul style="list-style-type: none">(i). have an FRL not less than 90/90/90;(ii). extend for a distance of not less than 2m each side of the centre-line of the fire hydrant riser; and(iii). extend to a height not less than 3m above ground level.		
(b)	if located not more than 3.5m from the external wall and remote from the building, by either —		
	<ul style="list-style-type: none">(i). the external wall of the building that confirms to Item (a); or(ii). a freestanding wall or similar construction that –<ul style="list-style-type: none">(A) has an FRL not less than 90/90/90;(B) extends not less than 2m each side of the centre-line of the fire hydrant riser;(C) extends to a height not less than 3m above ground level; and(D) is located immediately behind the fire hydrant and between the building and the fire hydrant.		
(c)	if located not less than 3.5m but not more than 10m from the external wall of the building, by a freestanding wall or similar construction that —		
	<ul style="list-style-type: none">(i). has an FRL not less than 90/90/90;(ii). extends for a distance of not less than 1m each side of the centre-line of the fire hydrant valve outlet;(iii). extends for a height of not less than 2m above ground level; and(iv). is located immediately behind the fire hydrant and between the building and the fire hydrant.		
6.11 Pump room of enclosure			

Part E1 – Fire Fighting Equipment			
Clause	Description	Status	Comments
6.11.1 General			
Pumpsets and associated equipment shall be installed within a waterproof room or enclosure that —			
(i) only contains firefighting pumpsets and associated equipment;			
(ii) is secured to prevent the entry of unauthorized persons;			
(iii) is ventilated with fresh air to maintain the aspiration and cooling of pump drivers for the required duration of pump operation;			
(iv) is heated and insulated, where necessary, to prevent freezing and condensation from forming;			
(v) is identified by —			
(i). a fade-and weather-resistant sign, permanently affixed to the pumproom door, stating in capital letters not less than 50mm high, in a colour contrasting with the background, FIRE PUMP ROOM; and			
(ii). a red strobe light, activated by the operation of the fixed on-site pumps, located outside the building, adjacent to the door providing access to the pump room;			
(vi) is construction with an internal clearance of not less than 2.1m; and			
(vii) is sized to allow for pump maintenance and replacement to occur.			
6.11.2 Internal pump rooms			
Where the pump room is located within the protected building, the following shall apply:			
(a) Where a building is protected throughout by a sprinkler system conforming to AS 2118.1, AS 2118.4, AS 2118.6 or FPAA101H, the requirements of Item (b) need not apply.			
(b) A pump room shall have the following:			
(i). A fire resisting construction including walls and , where applicable, floor and roof that have an FRL not less than that required for a firewall for the building classification and type of construction applied to the building.			
(ii). Doorways protected with self-closing doors that have an FRL not less than that required for a fire wall required in Item (i), except that the door shall have an insulation level of not less than 30 min.			
(iii). Construction joints, service penetrations and other openings protected in a manner that maintains the FRL for the wall, roof or floor as required by Item (i).			
NOTE 1 Refer to the NCC for requirements related to the FRL of a fire wall, roof, or floor for different building classifications.			
NOTE 2 Refer to the NCC for requirements relating to construction joints, service penetrations and other openings in a fire wall, roof, or floor.			
(c) The pumproom shall have a door leading directly to —			
(i). road or open space;			
(ii). an airlock or smoke lobby that leads to —			
(A) a fire-isolated passageway or stair, leading to road or open space; and			
(B) a fire-isolated passageway or stair, pressurized in accordance with AS/NZS 1668.1, leading to road or open space.			
NOTE 3 Refer to the NCC for more information on the construction of an airlock or smoke lobby.			
(d) Where a compression ignition engine pumpset is installed —			
(i). the exhaust system for the pumpset shall discharge outside the building or to a mechanical exhaust system capable of safely discharging the pump exhaust gases;			
(ii). the discharge outlet from the exhaust system shall be not less than 2.7m above a path of travel or road.			

Part E1 – Fire Fighting Equipment			
Clause	Description	Status	Comments
	<p>NOTE 4 The exhaust gases from the exhaust system discharge outlet should discharge clear of any ventilation, door or window openings within the building for the health and safety of persons within the building and at a height and orientation so as not to affect any person in the vicinity of the discharge outlet.</p>		
	<p>6.11.2 External pump rooms or enclosures</p> <p>Where a pump room or enclosure is located externally to the protected building the following apply:</p> <p>(a) Where a building is protected throughout by a sprinkler system conforming to AS 2118.1, AS 2118.4, AS 2118.6 or FPAA101H, or the pumphoom is located more than 6m from the protected building, the requirements of Item (b) do not have to be applied.</p> <p>(b) Any parts of the pump room or enclosure located not more than 6m from the protected building shall have the following:</p> <ul style="list-style-type: none"> (i). A fire resisting construction including walls and, where applicable, floor and roof that has an FRL not less than that required for a firewall for the building classification and Type of Construction applied to the building. (ii). Doorways protected with self-closing doors having an FRL not less than that required for a fire wall as required in Item (i), except that the door shall have an insulation level of at least 30 min. (iii). Construction joints, service penetrations, service penetrations for ventilation that face the protected building and other openings, protected in a manner that maintains the FRL for the wall, roof or floor as required by Item (i). <p>NOTE 1 Refer to the NCC for requirements relating to the FRL of a fire wall, roof, or floor for different building classifications.</p> <p>NOTE 2 Refer to the NCC for requirements relating to construction joints, service penetrations and other openings in a fire wall, roof, or floor.</p> <p>(c) The pumphoom shall be located not more than 20m from a hardstand.</p> <p>(d) The pumphoom shall be located not less than 10 m from —</p> <ul style="list-style-type: none"> (i). any high voltage electrical distribution equipment, such as transformers and distribution boards; (ii). any stored dangerous goods (e.g. LPG, petroleum, propane); and (iii). any external combustible storage (e.g. palleted combustible storage items). <p>(e) Where a compression ignition engine pumpset is installed –</p> <ul style="list-style-type: none"> (i). the exhaust system from the pumpset shall discharge outside the building or to a mechanical exhaust system that is capable of safely discharging the pump exhaust gases; and (ii). the discharge outlet from the exhaust shall be located not less than 2.7 m above a path of travel or road. <p>NOTE 3 The exhaust gases from the exhaust system discharge outlet should discharge clear of any ventilation, door or window openings within the building for the health and safety of persons within the building and at a height and orientation so as not to affect any person in the vicinity of the discharge outlet.</p>		

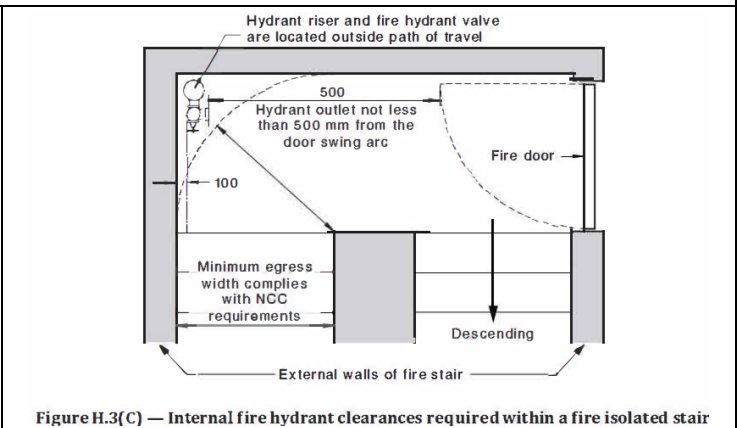
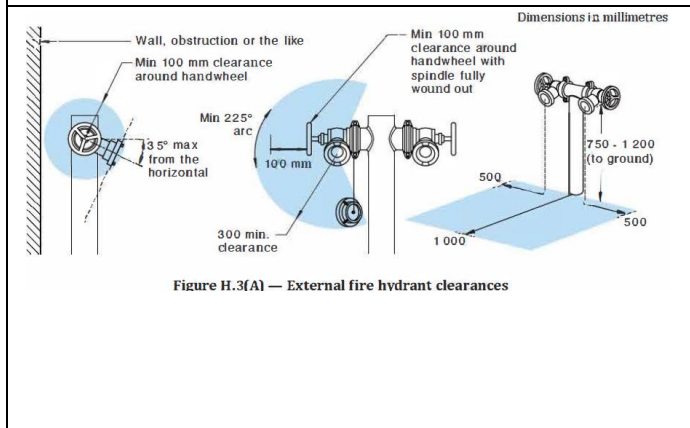

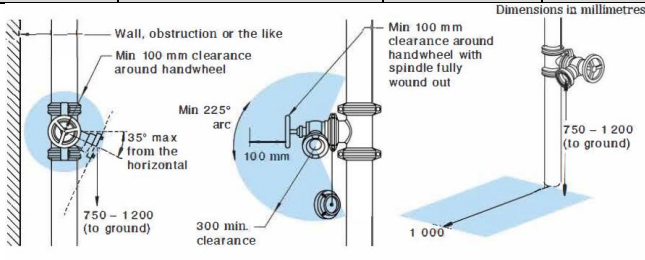
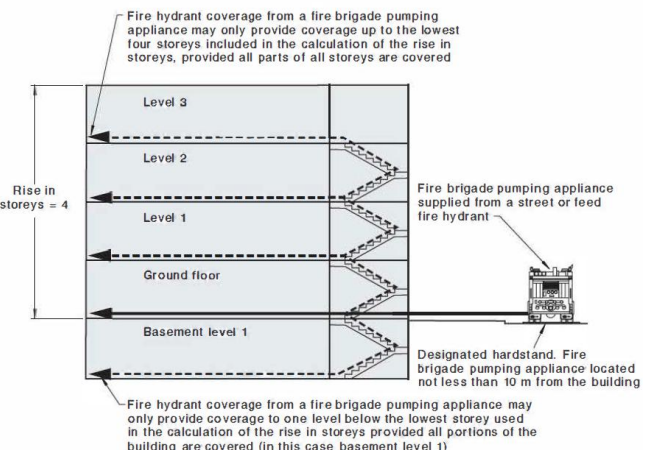
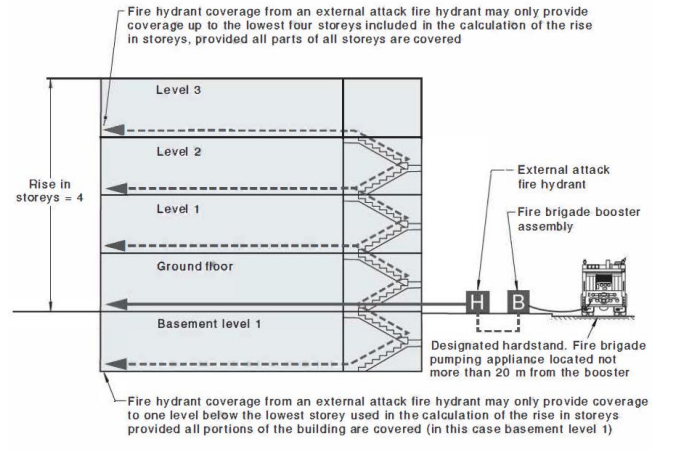
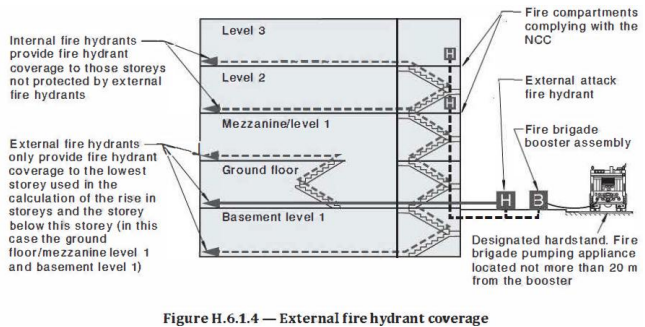
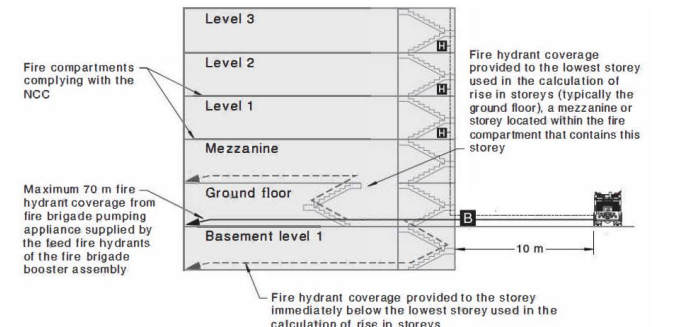
Part E1 – Fire Fighting Equipment			
Clause	Description	Status	Comments
	 <p>Figure H.3(B) — Internal fire hydrant clearances</p>		
	 <p>Figure H.6.1.2(A) — Coverage from a fire brigade pumping appliance</p>		 <p>Figure H.6.1.3 — External attack fire hydrant coverage</p>
	 <p>Figure H.6.1.4 — External fire hydrant coverage</p>		 <p>Figure H.6.4 — Feed fire hydrant coverage from a fire brigade booster assembly</p>
E1D3	Fire hose reels	CRA	<p>Fire hose reels coverage is required within the carpark portions of the building if a hydrant is located within the building.</p> <p>Where fire hose reels are located within the building, they are to be within 4m of an exit, additional hose reels may be provided for coverage purposes however are to be located in a path of travel to an exit.</p> <p>Fire hose reels are to be installed accordance with AS2441.</p> <p>Final plans and a design certificate from a qualified hydraulic engineer prior to the issue of a Construction Certificate.</p>

Part E1 – Fire Fighting Equipment			
Clause	Description	Status	Comments
E1D6	Where sprinklers are required: Class 2 and 3 buildings other than residential care buildings	CRA	A Class 2 or 3 building (excluding a building used as a residential care building) and any other class of building (excluding a building used as a residential care building) containing a Class 2 or 3 part requires sprinkler protection throughout the whole building if any part of the building has a rise in storeys of 4 or more and an effective height of more than 25m. The building is required to be sprinkler protected throughout. Refer to Clause E1D4 & E1D5 for further details.
E1D7	Where sprinklers are required: Class 3 building used as a residential care building	N / A	
E1D8	Where sprinklers are required: Class 6 building	N / A	
E1D9	Where sprinklers are required: Class 7a building, other than an open-deck carpark	CRA	In a Class 7a building, other than an open-deck carpark, sprinklers are required in fire compartments where more than 40 vehicles are accommodated. Final plans and a design certificate from a qualified hydraulic engineer prior to the issue of a Construction Certificate.
E1D10	Where sprinklers are required: Class 9a health-care building used as a residential care building and Class 9c buildings	N / A	
E1D11	Where sprinklers are required: Class 9b buildings	CRA	(1) In a Class 9b building, other than an early childhood centre, see Part I1. (2) In a building containing a Class 9b early childhood centre, sprinklers are required throughout the whole building, including any part of another class.
E1D12	Where sprinklers are required: additional requirements	N / A	
E1D13	Where sprinklers are required: occupancies of excessive hazard	N / A	

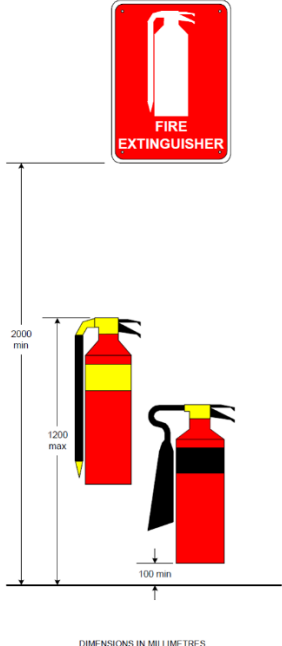
Part E1 – Fire Fighting Equipment			
Clause	Description	Status	Comments
E1D14	Portable fire extinguishers	CRA	<p>Portable fire extinguishers are required to be provided in accordance with Clause E1D14 of the BCA and AS 2444.</p> <p>For Class 2, 3 or 5 buildings or Class 4 parts of a building portable fire extinguishers must be provided to serve the whole storey where one or more internal fire hydrants are installed and when fire hydrants are not installed to serve any fire compartment which a floor area greater than 500m² (for the purposes of this Clause a Class 2, 3 or 4 parts of a building are considered to be a fire compartment).</p> <p>Portable fire extinguishers provided in a Class 2 or 3 building or Class 4 part of a building must be:</p> <ul style="list-style-type: none"> • An ABE type fire extinguisher; and • A minimum size of 2.5kg; and • Distributed outside a sole-occupancy unit to serve the storey at which they are located and ensure that the travel distance from the entrance doorway of any sole-occupancy unit to the nearest fire extinguisher is not more than 10m. <p>Details demonstrating compliance with this clause must be incorporated into the architectural drawings prior to the issue of a Construction Certificate.</p>
AS 2444—2001	 <p>DIMENSIONS IN MILLIMETRES</p> <p>FIGURE 3.2 MOUNTING HEIGHTS FOR PORTABLE FIRE EXTINGUISHERS AND LOCATION SIGNS</p>	10	<p>Signs are to be installed clearly over or directly adjacent to Portable fire extinguishers.</p> <ul style="list-style-type: none"> – Each extinguisher shall be located in a conspicuous and readily accessible position. Extinguishers shall not be located in positions where access could present a hazard to the potential user. Where practicable, extinguishers shall be located along normal paths of travel and near exits. (Max 15m from each other etc) – Extinguishers Signs must be shown and shall be mounted not less than 2.0 m above floor level, or at a height that makes them most apparent to a person of average height and visual acuity approaching the extinguisher location. <p>In addition to the location sign referred to in Clause 3.3 of AS2444, the cabinet or enclosure shall be marked with the words 'FIRE EXTINGUISHER' in letters at least 32 mm high in a colour contrasting with the background unless the door has not less than 50% of its surface area fabricated from transparent material that permits visual identification of the cabinet's contents. Signs are to be installed clearly over or directly adjacent to Portable fire extinguishers.</p> <ul style="list-style-type: none"> – Each extinguisher shall be located in a conspicuous and readily accessible position. Extinguishers shall not be located in positions where access could present a hazard to the potential user. Where practicable, extinguishers shall be located along normal paths of travel and near exits. (Max 15m from each other etc) – Extinguishers Signs must be shown and shall be mounted not less than 2.0 m above floor level, or at a height that makes them most apparent to a person of average height and visual acuity approaching the extinguisher location.

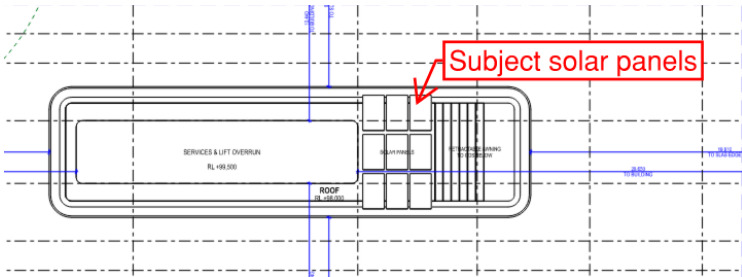
Part E1 – Fire Fighting Equipment			
Clause	Description	Status	Comments
E1D15	Fire control centres	PS	<p>The building retains an effective height of more than 25m and therefore must be provided with a fire control centre as required by Clause E1D15 of the BCA.</p> <p>A Class 6, 7, 8 or 9 building with a total floor area of more than 18,000m² is required to be provided with a fire control centre facility in accordance with Specification 19.</p> <p>A fire control centre is required on the ground floor, not more than 300m level difference from the street level and must comply with all relevant parts of Specification 19 of the BCA.</p> <p>The subject fire control centre does not appear to be in sight from the main building entry.</p>  <p>Compliance can be achieved via undertaking a fire engineering performance solution prior to issue of the Construction Certificate.</p>
E1D16	Fire precautions during construction	CRA	<p>During construction, not less than one fire extinguisher to suit Class A, B and C fires is required for each storey, and is required to be located adjacent to each exit.</p>
E1D17	Provisions for special hazards	PS	<p>Suitable additional provision must be made if special problems of fighting fire could arise because of-</p> <ul style="list-style-type: none"> (a) The nature or quantity of materials stored, displayed or used in a building or on the allotment; or (b) The location of the building in relation to a water supply for fire-fighting purposes. <p>Solar Panels</p> <p>Solar photovoltaic (PV) (solar panels) are recommended to be provided with a performance solution due to the excessive hazard.</p> 

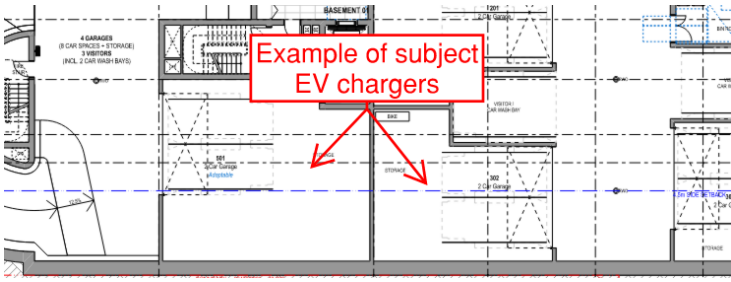
Part E1 – Fire Fighting Equipment			
Clause	Description	Status	Comments
			<p>Electric Vehicle Chargers</p> <p>Electric vehicle (EV) chargers are recommended to be provided with a performance solution due to the excessive hazard.</p>  <p>Compliance can be achieved by undertaking a fire engineering performance solution prior to the issue of the Construction Certificate. Refer to Appendix C for further information.</p>

General Fire Service Signage	
<p>FIRE HOSE REEL</p> <p>FIRE HYDRANT BOOSTER</p> <p>FIRE EXTINGUISHER</p> <p>SPRINKLER STOP VALVE INSIDE</p> <p>FIRE PANEL</p>	<p>FIRE HYDRANT PUMP – DO NOT SWITCH OFF</p> <p>SPRINKLER BOOSTER CONNECTION</p> <p>FIRE CONTROL ROOM</p>

Part E2 – Smoke Hazard Management			
Clause	Description	Status	Comments
E2D1	Deemed-to-Satisfy Provisions	-	
E2D2	Application of Part	Noted	Part is not applicable to open-deck car parks, open spectator stands or Class 8 electricity network substations with a floor area not more than 200m ² , located within a multi-classified building.
E2D3	General requirements	CRA	<p>The building must be provided with an automatic smoke detection and alarm system, and smoke detectors complying with Specification 20 and a Building Occupant Warning System (BOWS).</p> <p>Details and a design certificate will be required by a qualified electrical engineer prior to the issue of a Construction Certificate.</p>
E2D4	Fire-isolated exits	CRA	<p>Stair Pressurisation System</p> <p>The proposed fire isolated stairways serving the basement and lower ground floor levels and residential levels are to be provided with a stair pressurisation system installed in accordance with AS 1668.1-2015.</p> <p>Final detailing of the stair pressurisation system is to be provided to the PCA and submitted with the Construction Certificate Documentation.</p> <p>Clause S20C6 of Specification 20</p> <p>Smoke detectors required to activate air pressurisation systems for fire-isolated exits and zone pressurisation systems must—</p> <ul style="list-style-type: none"> • be installed in accordance with AS 1670.1-2018; and • have additional smoke detectors installed adjacent to each bank of lift landing doors set back horizontally from the door openings by a distance of not more than 3 m. <p>Smoke detectors provided to activate a zone control system must:</p> <ul style="list-style-type: none"> • Either form part of a building fire or smoke detection system complying with AS 1670.1-2018 or be a separate system dedicated system incorporating control and indicating equipment complying with AS 1670.1-2018; and • Activate building occupant warning system complying with Clause S20C7 except that smoke detectors provided solely to initiate shutdown of air handling systems in accordance with (2)(a) need not activate a building occupant warning system. <p>Details and a design certificate will be required by a qualified electrical engineer prior to the issue of a Construction Certificate.</p>
E2D5	Buildings more than 25 m in effective height: Class 2 and 3 buildings and Class 4 part of a building	CRA	<p>Class 2 Parts of the Building</p> <p>Each Class 2 SOU is to incorporate an AS3786 smoke alarm system which is connected to the consumer mains source and interconnected throughout the SOU.</p> <p>The common areas of the building are to incorporate a smoke detection and alarm system installed in accordance with AS1670.1-2018 and</p>



Part E2 – Smoke Hazard Management			
Clause	Description	Status	Comments
			<p>activate a Building Occupant Warning System (BOWS) being sound pressure <i>within</i> each SOU door is to achieve no less than 85 dB(A).</p> <p>Details and a design certificate will be required by a qualified electrical engineer prior to the issue of a Construction Certificate.</p> <p>Clause S20C7 of Specification 20</p> <p>Subject to E4D9, a building occupant warning system provided as part of a smoke hazard management system must comply with Clause 3.22 of AS 1670.1-2018 to sound throughout all occupied areas except:</p> <ul style="list-style-type: none"> In a Class 2 or 3 building or Class 4 part of a building provided with a smoke alarm system in accordance with Clause 3 or Specification 20 where the sound pressure within each SOU door is to achieve no less than 85 dB(A). <p>Details and a design certificate will be required by a qualified electrical engineer prior to the issue of a Construction Certificate.</p>
E2D6	Buildings more than 25 m in effective height: Class 5, 6, 7b, 8 and 9b buildings	CRA	<p>The Class 5, 6, 7b, 8 or 9b building or part of a building must be provided with a zone pressurisation system between vertically separated fire compartments in accordance with AS 1668.1 where there is more than fire compartment containing these classifications.</p> <p>The assembly parts of the building are to be provided with a fire detection and alarm system installed in accordance with AS 1670.1-2015.</p> <p>Details and a design certificate will be required by a qualified electrical engineer prior to the issue of a Complying Development Certificate.</p>
E2D7	Buildings more than 25 m in effective height: Class 9a buildings	N / A	
E2D8	Buildings not more than 25 m in effective height: Class 2 and 3 buildings and Class 4 part of a building	N / A	
E2D9	Buildings not more than 25 m in effective height: Class 5, 6, 7b, 8 and 9b buildings	N / A	
E2D10	Buildings not more than 25 m in effective height: large isolated buildings subject to C3D4	N / A	



Part E2 – Smoke Hazard Management			
Clause	Description	Status	Comments
E2D11	Buildings not more than 25 m in effective height: Class 9a and 9c buildings	N / A	
E2D12	Class 7a buildings	CRA	<p>The carpark levels are to be provided with a mechanical ventilation system in accordance AS 1668.2 and must comply with Clause 5.5 of AS 1668.1 except that:</p> <ul style="list-style-type: none"> The carpark is to be provided with fans with metal blades suitable for operation at normal temperature and electrical power and control cabling need not be fire rated. Upon activation of the BOWS, the fans are to run at full speed. <p>Details and a design certificate will be required by a qualified mechanical engineer prior to the issue of a Construction Certificate.</p>
E2D13	Basements (other than Class 7a buildings)	CRA	<p>A basement not counted in the RIS with a total floor area of more than 2000 m², if not more than 2 below ground storey, must be provided with:</p> <ul style="list-style-type: none"> A zone pressurisation system between vertically separated fire compartments in accordance with AS 1668.11 or An automatic smoke detection and alarm system complying with Specification 20; or A sprinkler system (other than FPAA101D or FPAA101H system) complying with Specification 17. <p>If more than 20 below ground storeys, a sprinkler system (other than a FPAA101D or FPAA101H system) complying with Specification 17 must be provided.</p> <p>Details and a design certificate will be required by a qualified mechanical engineer prior to the issue of a Construction Certificate.</p>
E2D14	Class 6 buildings – in fire compartments more than 2000m ² : Class 6 building (not containing an enclosed common walkway or mall serving more than one Class 6 sole-occupancy unit)	N / A	
E2D15	Class 6 buildings – in fire compartments more than 2000m ² : Class 6 building (containing an enclosed common walkway or mall serving more than one Class 6 sole-occupancy unit)	N / A	



Part E2 – Smoke Hazard Management			
Clause	Description	Status	Comments
NSW E2D16	Class 9b – assembly buildings: all	CRA	<p>A building or part of a building used as an assembly building must be provided with automatic shutdown of any air-handling system (other than non-ducted individual room units with a capacity of not more than 1000 L/s and miscellaneous exhaust air systems installed in accordance with Sections 6 and 6 of AS166831) which does not form part of the smoke hazard management system, on the activation of –</p> <ul style="list-style-type: none"> • Smoke detectors installed complying with S20C6; and • Any other installed fire detection and alarm system, including a sprinkler system (other than a FPAA101D or FPAA101H system) complying with Specification 17. <p>A basement not counted in the RIS in accordance with C2D3, less than 2000 m² used as an assembly building or part of an assembly building containing an auditorium or other public area, must be equipped with-</p> <ul style="list-style-type: none"> • An automatic smoke detection system in accordance with Specification 20; or • An automatic zone pressurisation system in accordance with AS1668.1 if the basement has more than one fire compartment; or if the basemen forms part of a multi fire compartmented building served by the zone pressurisation system or • A sprinkler system (other than a FPAA101D or FPAA101H system) complying with Specification 17. <p>Stages and backstages:</p> <ul style="list-style-type: none"> • For the purpose of this clause, where a stage is separated from the auditorium by a proscenium wall incorporating a proscenium opening, a backstage room or area that is not separated from the stage by construction having an FRL of not less than 60/60/60, is taken to form part of the stage. • A building or part of a building used as an assembly building which has a stage with a floor area of more than 50 m² and not more than 150 m², over the stage, be provided with- <ul style="list-style-type: none"> - An automatic smoke exhaust system complying with Specification 21; or - Roof mounted automatic smoke-and-head vents complying with NSW I4D59, in a single storey building or the top storey of a multi storey building. • A building or part of a building used as an assembly building which has a stage with a floor area of more than 150 m² must, over the stage, be provided with an automatic smoke exhaust system complying with Specification 21 <p>A building or part of a building used as an assembly building which has a stage equipped with means of flying scenery must, over the stage, be provided with an automatic smoke exhaust system complying with Specification 21.</p>

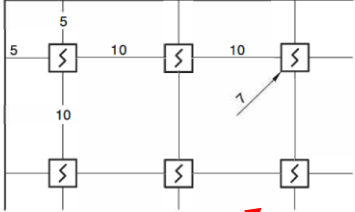
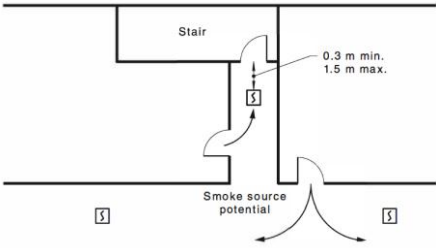
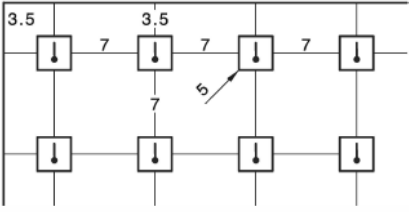
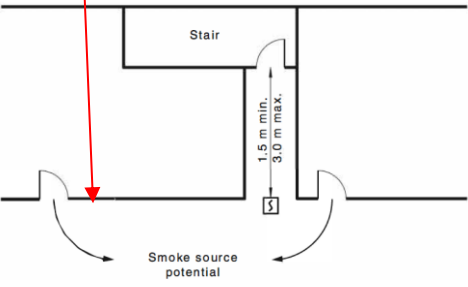

Part E2 – Smoke Hazard Management			
Clause	Description	Status	Comments
NSW E2D17	Class 9b – assembly buildings: night clubs, discotheques and the like	CRA	
NSW E2D18	Class 9b – assembly buildings: exhibition halls, museums and art galleries	CRA	
NSW E2D19	Class 9b – assembly buildings: other assembly buildings (not listed in NSW E2D16 to E2D18)	CRA	<p>Each fire compartment having a floor area of more than 2000 m² must be provided with:</p> <ul style="list-style-type: none"> • An automatic smoke exhaust system complying with Specification 21; or • If the building is single storey or the top storey of a multi storey building, roof mounted automatic smoke-and-heat vents complying with Specification 22; or • If the floor area of the fire compartment is not more than 5000 m² and the building has a RIS of not more than 2: <ul style="list-style-type: none"> - An automatic smoke detection and alarm system complying with Specification 20; or - A sprinkler system (other than a FPAA101D or FPAA101H system) complying with Specification 17 <p>Sporting complexes other than indoor sports stadiums (with total spectator seating for more than 1000 persons), churches and places of religious worship, and school classrooms are exemption from the above provisions.</p> <p>A building containing a Class 9b early childhood centre must be provided with an automatic smoke detection and alarm system complying with Specification 20 throughout the whole building, including any part of another class.</p> <p>Details and a design certificate will be required by a qualified electrical engineer prior to the issue of a Construction Certificate.</p>
NSW E2D20	Class 9b assembly buildings: other assembly buildings (not listed in NSW E2D16 to E2D19)	N / A	

Part E2 – Smoke Hazard Management			
Clause	Description	Status	Comments
	 <p>DIMENSIONS IN MILLIMETRES</p> <p>FIGURE 5.1.1(A) MAXIMUM SMOKE DETECTOR OR SMOKE ALARM SPACING LEVEL SURFACES</p> 		 <p>I.e.: Heat Detectors – AS1670.1</p> <p>I.e.: Smoke Detectors – AS1670.1</p>  <p>I.e.: Smoke Detectors – AS1668.1 (M/V Shutdown etc.)</p>
E2D21	Provision for special hazards	CRA	Additional smoke hazard measurements may be necessary due to the special characteristics, function/use of the building, materials stored in the building or mix of classifications within a building or fire compartment which are not addressed in E2D4 to E2D20.

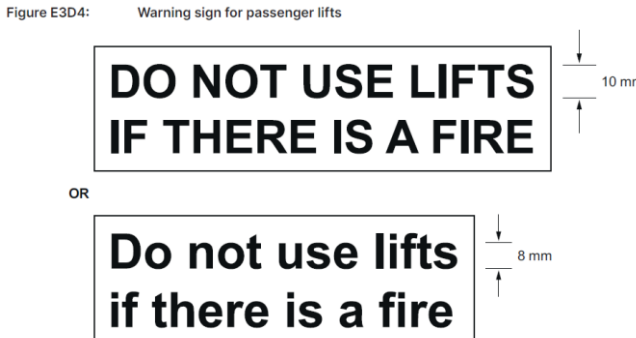
Part E3 – Lift Installations			
Clause	Description	Status	Comments
E3D1	Deemed-to-Satisfy Provisions	-	-
E3D2	Lift Installations	Noted	An electric passenger lift installation and an electrohydraulic passenger lift installation must comply with Specification 24. Final design to be confirmed at the Construction Certificate stage.
E3D3	Stretcher facility in lifts	CRA	A stretcher lift is required as the passenger lifts serve a storey above an effective height of more than 12 metres. (600mm wide * 2000mm long and 1400mm high). Please also note the minimum cart size under the Access to Premises Standard and AS1428.1:2021 requiring 1400mm x 1600mm along with the appropriate cart controls and display and hearing requirements. Note: The building also requires a stretcher lift because the building must be provided with emergency lifts in accordance with Clause E3D5 of the BCA. Final design to be confirmed at the Construction Certificate stage.
E3D4	Warning against use of lifts in fire	Noted	A warning sign is to be displayed where it can be readily seen near every call button of the passenger lift. The warning sign is to comply with the details and dimensions set out in Figure E3D4 of the BCA. Figure E3D4: Warning sign for passenger lifts 
E3D5	Emergency lifts	CRA	Emergency lifts (a) At least one emergency lift complying with (d) must be installed in— <ul style="list-style-type: none"> (i) a building which has an effective height of more than 25 m; and (ii) a Class 9a building in which patient care areas are located at a level that does not have direct egress to a road or open space. (b) An emergency lift may be combined with a passenger lift and must serve those storeys served by the passenger lift so that all storeys of the building served by passenger lifts are served by at least one emergency lift. (c) Where two or more passenger lifts are installed and serve the same storeys, excluding a lift that is within an atrium and not contained wholly within a shaft— <ul style="list-style-type: none"> (i) at least two emergency lifts must be provided to serve those storeys; and

Part E3 – Lift Installations			
Clause	Description	Status	Comments
			<p>(ii) if located within different shafts, at least one emergency lift must be provided in each shaft.</p> <p>(d) An emergency lift must—</p> <p>(i) be contained within a fire-resisting shaft in accordance with C3D11.</p> <p>Final design to be confirmed at the Construction Certificate stage.</p>
E3D6	Landings	CRA	<p>Access and egress to and from the lift well landings are to comply with Parts D2, D3 and D4 of the BCA.</p> <p>Ensure all lift landings achieve an unobstructed width of 1540mm x 2070mm as required by AS 1428.1-2021.</p> <p><u>Refer to Clause D4D4 of this report for further detail.</u></p> <p>To be confirmed with details provided at Construction Certificate stage or design statement.</p>
E3D7	Passenger lift types and their limitations	Noted	<p>In an accessible building, every passenger lift must be one of the following lift types, subject to the limitations (if any) of each lift type as outlined in Clause E3D7:</p> <ul style="list-style-type: none"> • Electric passenger lifts, electrohydraulic passenger lifts or inclined lifts; • Stairway platform lifts; • A low-rise platform lift; • A low-rise, low-speed constant pressure lift; • A small-sized, low-speed automatic lift.
E3D8	Accessible features required for passenger lifts	CRA	<p>A passenger lift within the building other than a stairway platform lift is to comply with several features from AS1735.12, including:</p> <ul style="list-style-type: none"> – Passenger protection system for a lift with power-operated doors; – 900mm minimum clearance through lift doors; – Lift landing doors at upper landings; – Lift car and landing control buttons; – Handrail to be provided within the cart; – Braille and location of Control buttons; – Lighting for an enclosed lift car; – Audio and Visual indicators for a lift serving more than 2 levels; and – Emergency hands-free communication. <p>Lift cart floor dimensions of not less than 2000mm x 1400mm (1.6m x 1.4m with 2m x 0.6m stretcher facility) to be provided as the lift is deemed to both travel greater than 12m and serve a storey with an effective height greater than 12m.</p> <p>Details verifying compliance must be included on the architectural plans prior to the issue of the Construction Certificate.</p>

Part E3 – Lift Installations			
Clause	Description	Status	Comments
E3D9	Fire service controls	CRA	<p>Passenger lift cars serving any storey above an effective height of 12m are to be provided with fire service controls in accordance with AS1735.2.</p> <p>Required in this instance as lift car is serving storey's above an effective height of 12m.</p>
E3D10	Residential care buildings	N / A	
E3D11	Fire service recall control switch	CRA	<p>Each group of lifts must be provided with one fire service recall control switch required by E3D9 that activates the fire service recall operation.</p> <p>Design verification to be provided prior to the issue of the Construction Certificate.</p>
E3D12	Lift car fire service drive control switch	CRA	<p>The lift car fire service drive control switch required by E3D9 must be activated from within the lift car.</p> <p>Design verification to be provided prior to the issue of the Construction Certificate.</p>

Part E4 – Visibility in an Emergency, Exit Signs and Warning Systems			
Clause	Description	Status	Comments
E4D1	Deemed-to-Satisfy Provisions	-	-
E4D2	Emergency lighting requirements	CRA	Emergency lighting is to be provided throughout the building in accordance with Clause E4D2 of the BCA. Drawings a design certificate will be required by a suitably qualified electrical engineer prior to the issue of a Construction Certificate.
E4D3	Measurement of distance	Noted	
E4D4	Design and operation of emergency lighting	CRA	Emergency lighting shall be provided throughout the building in accordance with the requirements of Clause E4D4 of the BCA and AS 2293.1. Details and a design certificate will be required by a suitably qualified electrical engineer prior to the issue of a Construction Certificate.
E4D5	Exit signs	CRA	Exit signs are to be provided in accordance with Clause E4D5 of the BCA.
	 <p>(a) Straight on from here (Refer to paragraph D3.3)</p> <p>(b) Left from here</p> <p>(c) Right from here</p>		<p>Exit signs must be clearly visible to person approaching the exit and must be installed on, above or adjacent to;</p> <ol style="list-style-type: none"> 1. A door providing direct egress from a storey to a stairway, passageway or ramp serving as a required exit. 2. A door from an enclosed stairway, passageway or ramp at every level of discharge to a road or open space. 3. A door serving as or forming part of a required exit in a storey required to be provided with emergency lighting. <p>A test switch is to be installed for each storey.</p> <p>Where and if requirements are altered under this proposal, details and a design certificate will be required by a suitably qualified electrical engineer prior to the issue of a Construction Certificate.</p>
E4D6	Direction signs	CRA	Where an exit is not readily apparent then exit signs with directional arrows must be installed in appropriate positions in corridors, hallways, lobbies and the like indicating the direction to a required exit in accordance with Clause E4D6 of the BCA. Where and if requirements are altered under this proposal, details and a design certificate will be required by a suitably qualified electrical engineer prior to the issue of a Construction Certificate.
E4D7	Class 2 and 3 buildings and Class 4 parts: exemptions	CRA	



Part E4 – Visibility in an Emergency, Exit Signs and Warning Systems			
Clause	Description	Status	Comments
E4D8	Design and operation of exit signs	CRA	<p>Exit signs are to operate in accordance with AS 2293.1 or for a photo luminescent exit sign, Specification E4D8 and be clearly visible at all times while the building is occupied.</p> <p>Where and if requirements are altered under this proposal, details and a design certificate will be required by a suitably qualified electrical engineer prior to the issue of a Construction Certificate.</p>
E4D9	Emergency warning and intercom systems	CRA	<p>A sound system and intercom system for emergency purposes complying with AS 1670.4 must be installed within the building as it exceeds 25m in effective height.</p> <p>Details and a design certificate will be required by a qualified electrical engineer prior to the issue of a Construction Certificate.</p>

SECTION F – HEALTH AND AMENITY

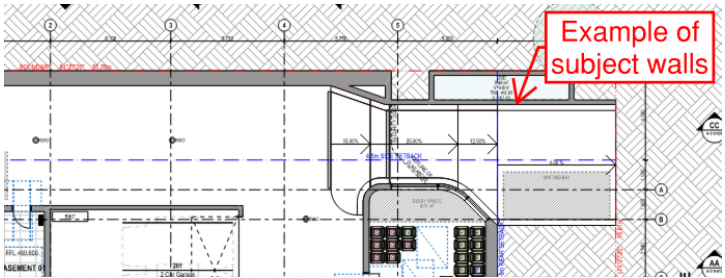
Part F1 – Surface water management, rising damp and external waterproofing			
Clause	Description	Status	Comments
F1D1	Deemed-to-Satisfy Provisions	Noted	Where a Deemed-to-Satisfy Solution is proposed, Performance Requirements F1P1 to F1P4 are satisfied by complying with F1D2 to F1D8.
F1D2	Application of Part	Noted	<p>(1) F1D4 and F1D5 do not apply to a roof with a covering complying with F3D2(a) to (d).</p> <p>(2) F1D3 to F1D5 do not apply to a balcony, podium or similar horizontal surface part of a building-</p> <p>(a) where the flooring is of timber decking or other perforated flooring; or</p> <p>(b) which is located directly above ground.</p>
F1D3	Stormwater drainage	CRA	<p>Stormwater drainage design shall be in accordance with AS/NZS 3500.3.</p> <p>Carpark wet walls</p> <p>Designer to confirm if the subject carpark is tanked or provided with a wet wall.</p>  <p>Details and a design certificate will be required by a suitably qualified hydraulic engineer prior to the issue of a Construction Certificate.</p>
F1D4	Exposed joints	CRA	<p>Exposed joints in the drainage surface on a roof balcony, podium or similar horizontal surface part a building must be protected in accordance with Section 2.9 of AS 46542 and not be located beneath or run through a planter box, water feature or similar part of the building.</p> <p>Details and a design certificate to be provided prior to the issue of a Construction Certificate.</p>
F1D5	External waterproofing membranes	CRA	<p>A roof, balcony, podium or similar horizontal surface part of a building must be provided with a waterproofing membrane consisting of materials complying with AS4654.1 and designed and installed in accordance with AS4654.2.</p> <p>Wind speed and N rating are required to calculate the waterproofing termination height and hob sizes.</p>

Part F1 – Surface water management, rising damp and external waterproofing			
Clause	Description	Status	Comments
			Details and a design certificate to be provided prior to the issue of a Construction Certificate.
F1D6	Damp-proofing	N / A	
F1D7	Damp-proofing of floors on the ground	CRA	A vapour barrier in accordance with AS2870 is to be provided beneath the basement floor slab. Details and design certification to be provided prior to the issue of a Construction Certificate.
F1D8	Subfloor ventilation	N / A	



Part F2 – Wet areas and overflow protection			
Clause	Description	Status	Comments
F2D1	Deemed-to-Satisfy Provisions	Noted	Where a Deemed-to-Satisfy Solution is proposed, Performance Requirements F2P1 and F2P2 are satisfied by complying with F2D2 to F2D4.
F2D2	Wet area construction	CRA	Shower enclosure surfaces, floor surfaces in bathrooms, shower rooms, slop hoppers, sink compartments, laundry and sanitary compartments is required to be waterproofed in accordance with AS 3740. Details and design certification to be provided prior to the issue of a Construction Certificate.
F2D3	Rooms containing urinals	CRA	Rooms containing urinals are to comply with Clause F2D3 of the BCA. Details and design certification to be provided prior to the issue of a Construction Certificate.
F2D4	Floor wastes	CRA	In a Class 2 or 3 building or Class 4 part of a building, a bathroom or laundry located at any level above a SOU or public must have a floor waste. The floor of each bathroom / laundry is to be graded to permit drainage to a floor waste. Architectural plans to confirm locations of proposed floor wastes throughout the development including, but not limited to: laundries; bathrooms; showers; balconies; open spaces and the like. The plans forming part of the Construction Certificate Application must detail compliance with the above.

Part F3 – Roof and wall cladding			
Clause	Description	Status	Comments
F3D1	Deemed-to-Satisfy Provisions	Noted	Where a Deemed-to-Satisfy Solution is proposed, Performance Requirement F3P1 is satisfied by complying with F3D2 to F3D5.
F3D2	Roof coverings	CRA	Roof coverings are to comply with the relevant Australian Standards as per Clause F3D2. Details and design certification to be provided prior to the issue of a Construction Certificate.
F3D3	Sarking	CRA	Sarking type materials used for weatherproofing of roofs and walls must comply with AS/NZS 4200 Parts 1 and 2. Details and design certification to be provided prior to the issue of a Construction Certificate.
F3D4	Glazed assemblies	CRA	Windows, sliding doors with a frame, adjustable louvres, shopfronts and window walls with one piece framing in an external wall must comply with AS 2047 requirements for resistance to water penetration. Details and design certification to be provided prior to the issue of a Construction Certificate.
F3D5	Wall Cladding	CRA	External wall cladding must comply with one of a combination of the following: <ul style="list-style-type: none"> • Masonry, including masonry veneer, unreinforced and reinforced masonry: AS 3700. • Autoclaved aerated concrete: AS 5146.3. • Metal wall cladding: AS 1562.1. Details and design certification to be provided prior to the issue of a Construction Certificate.

Part F4 – Sanitary and Other Facilities			
Clause	Description	Status	Comments
F4D1	Deemed-to-Satisfy Provisions	Noted	-
F4D2	Facilities in residential buildings	CRA	<p>Sanitary and other facilities for Class 2 and 3 buildings must be provided in accordance with Clause F4D2.</p> <p>Note: Sanitary facilities are not required to be provided within the common areas of a Class 2 building. If for any reason sanitary facilities are provided within the common areas of the building, not less than one (1) unisex accessible sanitary compartment is to be provided to serve the common areas of the building as per Clause F4D5(a) and F4D6(b) of the BCA.</p> <p>Laundry and Washtubs</p> <p>All Class 2 residential SOU's are to be provided with laundry and washtub facilities as required by this Clause.</p> <p>Details and design certification to be provided prior to the issue of a Construction Certificate.</p>
F4D3	Calculation of number of occupants and fixtures	CRA	<p>Floor area of each room is to be provided for the purpose of calculating occupant numbers within the building.</p> <p>Note: a unisex facility comprises one closet pan, one washbasin and means for the disposal of sanitary towels</p> <p>Details and design certification to be provided prior to the issue of a Construction Certificate.</p>
F4D4	Facilities in Class 3 to 9 buildings	CRA	<p>Except where permitted by the exemptions detailed within F4D4(3), (4), (7), and F4D5 (a), and F4D5(b), separate sanitary facilities for males and females must be provided for Class 3, 5, 6, 7, 8 or 9 buildings in accordance with Tables F4D4a-l.</p> <p>Details and design certification to be provided prior to the issue of a Construction Certificate.</p>
F4D5	Accessible sanitary facilities	CRA	<p>Accessible unisex sanitary compartments must be provided in accessible parts of the building in accordance with F4D6, and accessible unisex showers must be provided in accordance with F4D7.</p> <p>At each bank of toilets where there is one or more toilets in addition to an accessible unisex sanitary compartment at that bank of toilets, not less than one sanitary compartment suitable for a person with an ambulant disability for use by males and one sanitary compartment suitable for a person with an ambulant disability for use by females must be provided.</p> <p>WC detail sheet with all compliance requirements as per AS1428.1-2021 to be provided prior to issue of the Construction Certificate.</p> <p>Full compliance with AS1428.1-2021 is to be indicated on the Construction Certificate Plans.</p>

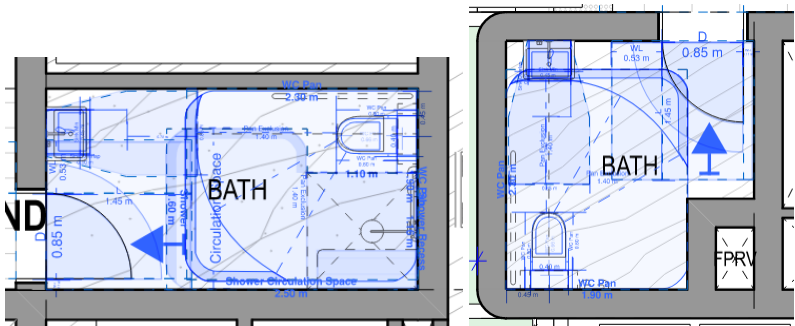
Part F4 – Sanitary and Other Facilities

Clause	Description	Status	Comments
F4D6	Accessible unisex sanitary compartments	CRA	<p>As determined in Clause F4D2, a sanitary facility in the common areas of the building is not required for this development.</p> <p>Where sanitary compartments are provided in common areas of a Class 2 building, not less than one (1) accessible toilet is required to be provided to serve the residential parts of the building.</p>  <p>Full compliance with AS1428.1:2021 is to be indicated on the Construction Certificate Plans.</p>

 	<p>Where existing accessible toilets are provided, the use of existing AS1428.1:2001 compliant toilet facility is deemed as acceptable only if the toilet actually complies with AS1248.1-2001.</p> <p>Full compliance with AS1428.1:2021 is to be indicated on the Construction Certificate plans or via Design Certificate.</p> <p>Where two or more of each type of accessible unisex sanitary facility are provided, the number of left and right handed mirror image facilities must be provided as evenly as possible. For example:</p> <ul style="list-style-type: none"> - Ground floor <i>RH Transfer</i> - First Floor <i>LH Transfer etc.</i>
---	--

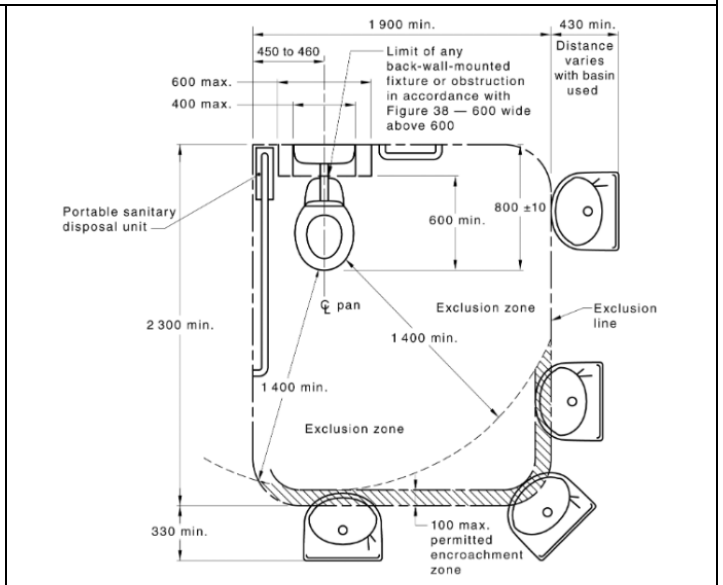
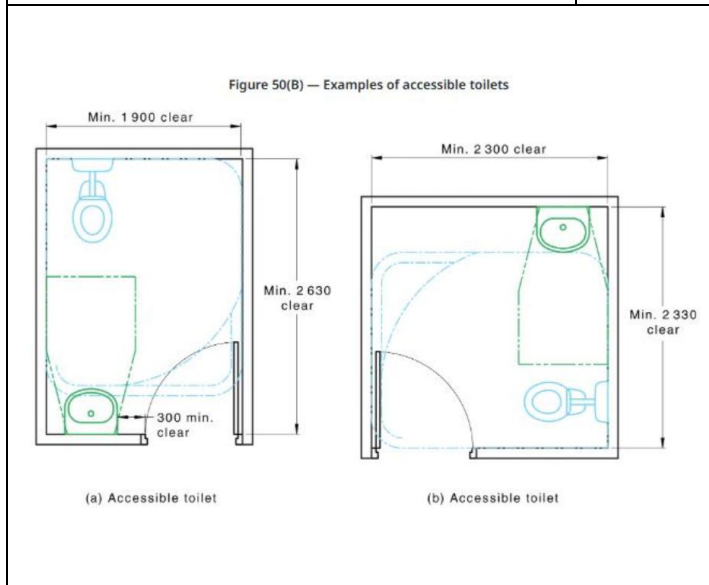



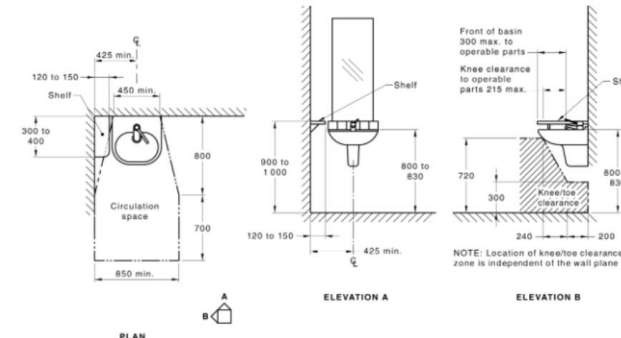
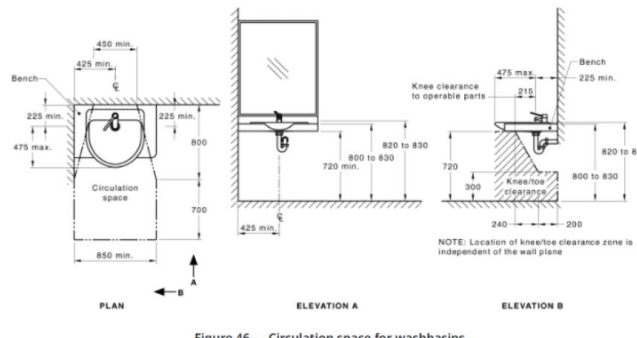
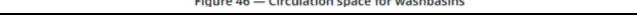

Part F4 – Sanitary and Other Facilities

Clause	Description	Status	Comments
<p>Figure 50(A) — Examples of accessible bathrooms</p> <p>Dimensions in millimetres</p> <p>(a) Backflow prevention device and restrictor device required</p> <p>(b) Backflow prevention device and restrictor device may be required based on hose location</p>	<p>(c) Backflow prevention device and restrictor device not required</p> <p>(d) Backflow prevention device and restrictor device not required</p> <p>NOTE A backflow prevention device may be required if the hose is longer than 1 500 mm.</p>		
<p>(a) Side approach</p> <p>(b) Side approach</p> <p>(c) Front approach</p>	<p>(a) Side approach</p> <p>(b) Side approach</p> <p>(c) Front approach</p>		
<p>(a) Side view</p> <p>(b) Front view</p>	<p>(a) Side view</p> <p>(a) Front view</p>		
<p>(i) Option A</p> <p>(ii) Option B</p>	<p>(b) Grabrail at back of pan with surface-mounted cistern and sectional view of grabrail at side of pan</p> <p>(c) Grabrail at back of pan with concealed or remote cistern and sectional view of grabrail at side of pan</p>		<p>Typical washbasin</p>

Part F4 – Sanitary and Other Facilities			
Clause	Description	Status	Comments
	<p>Figure 44(B) — Wall-mounted washbasin installation — other than for sole-occupancy unit</p> <p>Dimensions in millimetres</p>  <p>Figure 45 — Washbasin for accessible sole-occupancy unit</p> <p>Dimensions in millimetres</p> 		
			<p>Figure 46 — Circulation space for washbasins</p> 
	<p>Accessible Toilet(s)</p> <p>The designated accessible toilet(s) provided are required to include all items (washbasin, WC pan, shower, seat, etc), exculsion zones and circulation spaces required Sections 12 & 14 of AS 1428.1-2021:</p> <p>Full compliance with AS 1428.1-2021 is to be indicated on the Construction Certificate Plans.</p>		
	<p>Details for an Accessible Toilet: (Checklist)</p> <ul style="list-style-type: none"> – The toilet is to be signed according to AS1428.1, with Left or Right hand transfer. – Door clearances shall be in accordance with the relevant doors size and approach form both sides. – Doors are to have a staged closer, if it opens outwards, must also incorporate a closer which hold the door closed without pulling the door closed via a handle. – Doors shall be provided with an in-use indicator and a bolt or catch. Where a snib catch is used, the snib handle shall have a minimum length of 45 mm from the centre of the spindle. In an emergency, the latch mechanism shall be openable from the outside. – Toilet pan and wash basin are located in accordance with the diagrams with the required clearances, – All hand rails are installed and are structural (110N), – Flushing control are automatic or push action in the required zone, – An emergency light is also to be installed within the toilet. – A mirror is to be installed not less than 350mm wide by 900mm tall. <ul style="list-style-type: none"> ○ Located above the sink, ○ Flat against the wall. – A shelf is to be installed next to the basin @ 900-1000mm from the floor with a minimum width of 120-150mm by 300-400mm. – Where provided, soap dispensers, towel dispensers, hand dryers and similar fittings shall be operable by one hand, and shall be installed with the height of their operative component or outlet not less than 900 mm and not more than 1100 mm above the plane of the finished floor, and no closer than 500 mm from an internal corner. – A clothes-hanging device shall be installed 1200 mm to 1350 mm above the plane of the finished floor and not less than 500 mm out from any internal corner. 		

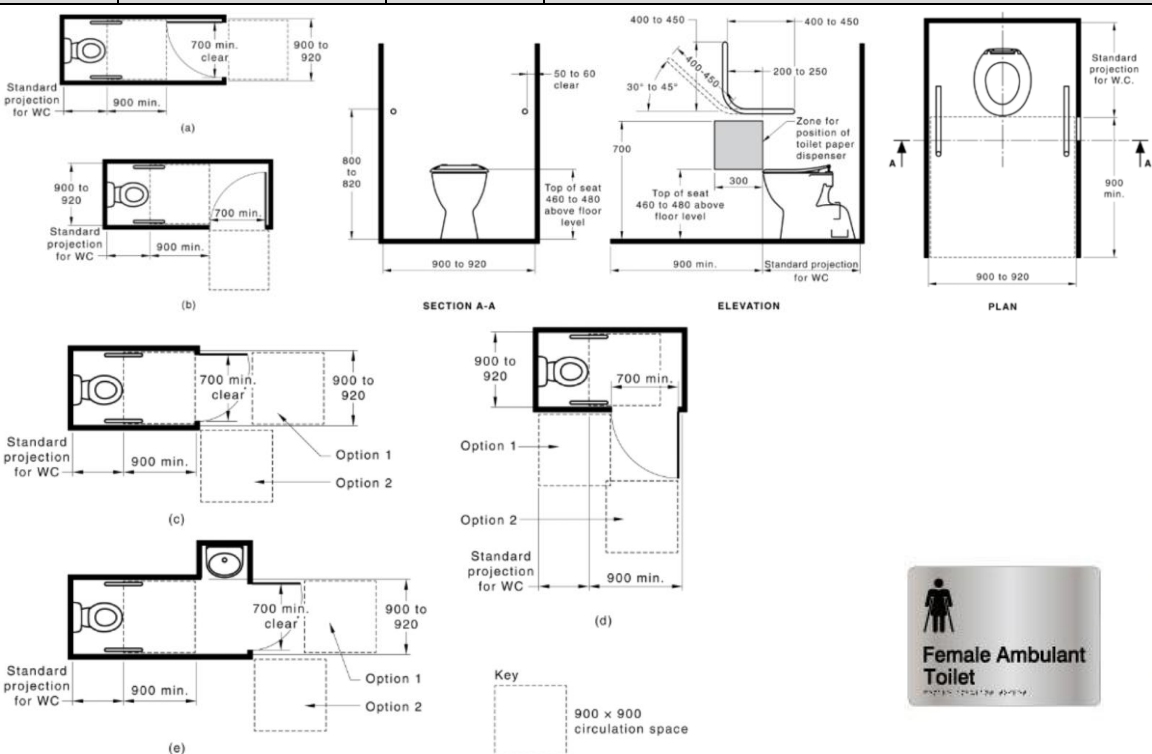
Part F4 – Sanitary and Other Facilities

Clause	Description	Status	Comments
			

Ambulant Cubicle

Any toilet block is also to accommodate at least one ambulant cubicle in **both** the *Male* and *Female* banks. The designated ambulant cubicles are to comply with Sections 13 and 14 of AS1428.1-2021.

Details for an Ambulant Cubicle: (Checklist)

- The toilet is to be signed according to AS1428.1, on the cubicle door,
- Door clearances shall be in accordance with the relevant doors size and approach form both sides. (900*900 pads)
- Cubicle is 900mm wide, Doors are 700mm and must also incorporate a closer or handle.
- Doors shall be provided with an in-use indicator and a bolt or catch. Where a snib catch is used, the snib handle shall have a minimum length of 45 mm from the centre of the spindle. In an emergency, the latch mechanism shall be openable from the outside.
- Toilet pan and wash basin are located in accordance with the diagrams with the required clearances,
- All hand rails are installed and are structural (110N),
- A clothes-hanging device shall be installed 1350 mm to 1500mm above the plane of the finished floor and not less than 500 mm out from any internal corner.

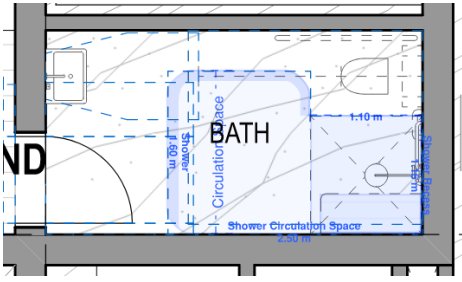
Part F4 – Sanitary and Other Facilities			
Clause	Description	Status	Comments
F4D7	Accessible unisex showers	CRA	<p>In a Class 2 building, where showers are provided in common areas, not less than 1 accessible shower is required to be provided.</p> <p>If accessible showers are provided in common areas, full compliance with AS1428.1:2021 to be indicated on the Construction Certificate Plans.</p>  <p>Full compliance with AS1428.1-2021 is to be indicated on the Construction Certificate Plans.</p>

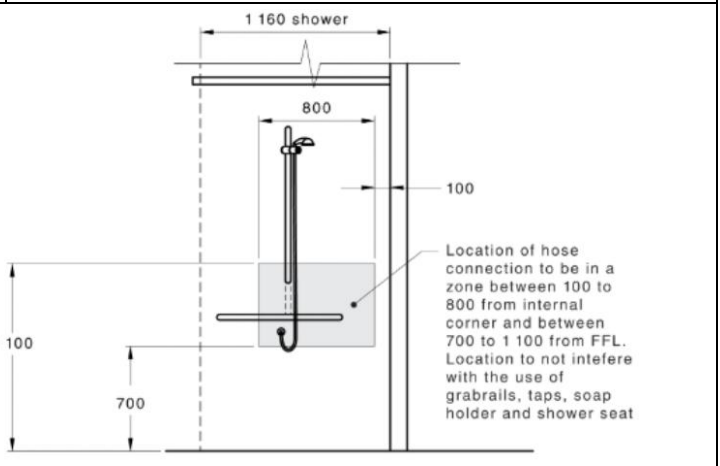
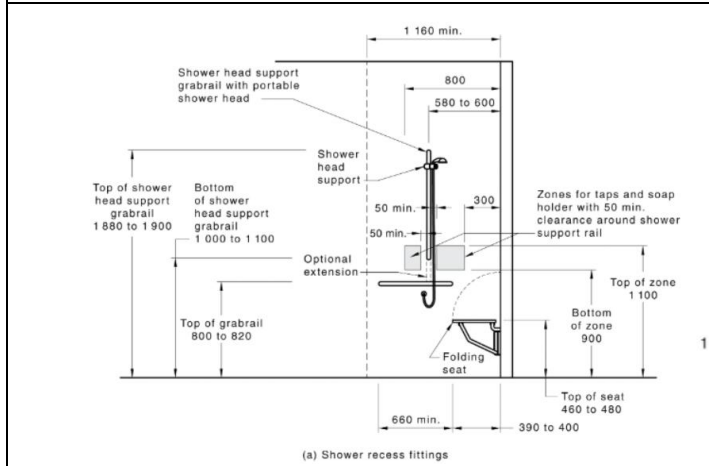
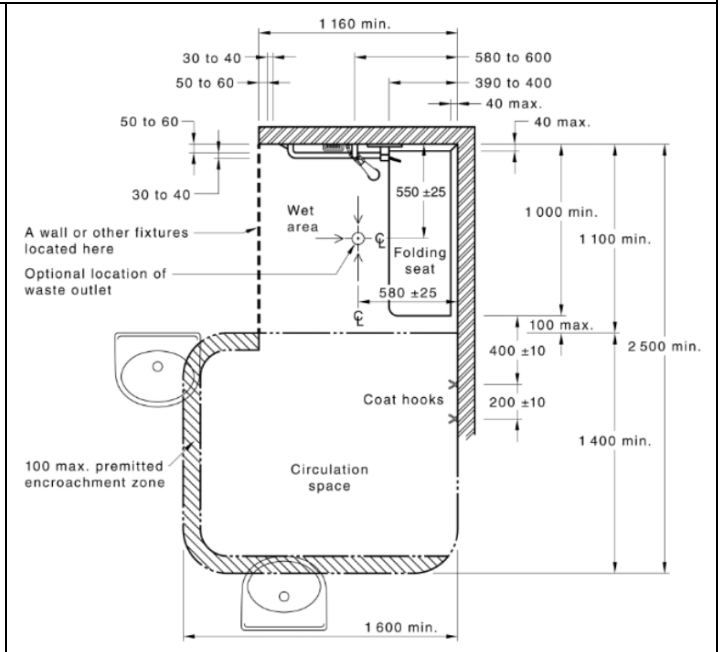
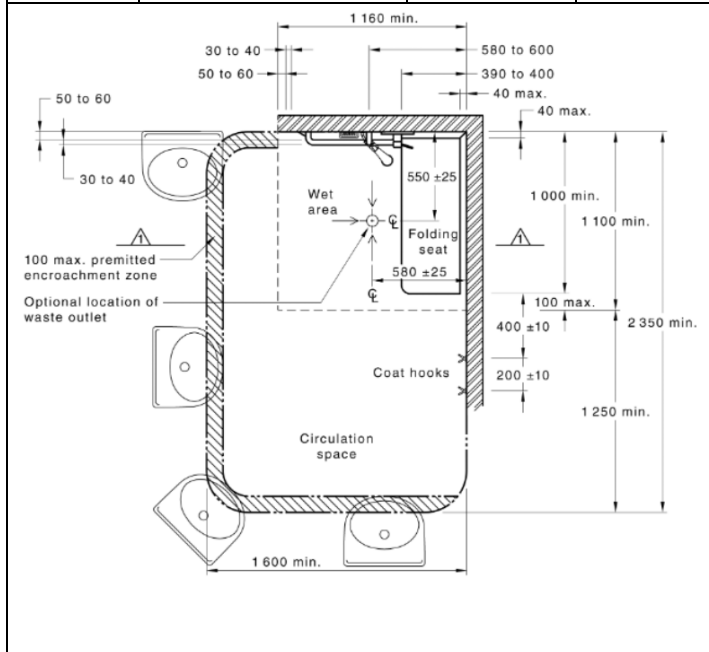

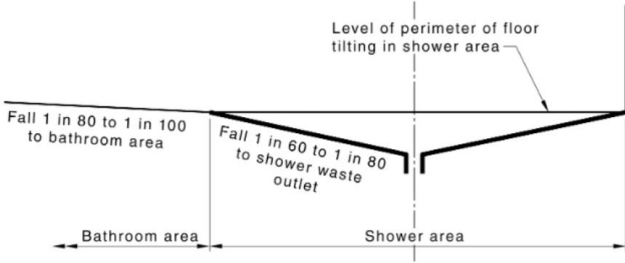
Part F4 – Sanitary and Other Facilities			
Clause	Description	Status	Comments
			
Details for an Accessible Shower: (Checklist) <ul style="list-style-type: none"> – Shower recess and circulation spaces to be provided in accordance with the diagrams with the required clearances. – Grabrails, shower hose fittings, taps, soap holder, shelf (if provided) and the folding seat are the only fixtures permitted in the spaces. – Not less than two clothes-hanging devices to be provided within reach of the shower seat. Clothes-hanging device shall be installed 1200 mm to 1350 mm above the plane of the finished floor and not less than 500 mm out from any internal corner. – The floor of the shower recess and associated circulation spaces are to be self-draining. The bathroom area is to be provided with a gradient between 1 in 80 to 1 in 100, and the shower area is to be provided with a gradient between 1 in 60 to 1 in 80. – The shower entry recess is to be provided without a step-down, raised step kerb or hob. – Waste outlet for the shower to be provided in accordance with the diagram. – Curtain or door to be provided which maintains the required circulation spaces. – Shower head grabrails are installed and are structural (110N), – Adjustable hand-held shower head to be provided with a flexible hose of min 1500mm length, to be located at heights between 1000mm and 1800mm above the finished floor. – Tap be installed in the required zone. – Folding seat are installed and are structural (1100N), 			
F4D8	Construction of sanitary compartments	CRA	Doors to the fully enclosed toilets are to open outwards, slide or be readily removable from the outside of the sanitary compartment unless there is a clear space of at least 1.2m between the closet pan within the sanitary compartment and the nearest part of the doorway. Plans submitted with the Construction Certificate Application must detail compliance with the above.
F4D9	Interpretation: Urinals and washbasins	Noted	
F4D10	Microbial (legionella) control	N / A	Not Applicable in NSW
F4D11	Waste management	N / A	
F4D12	Accessible adult change facilities	N / A	

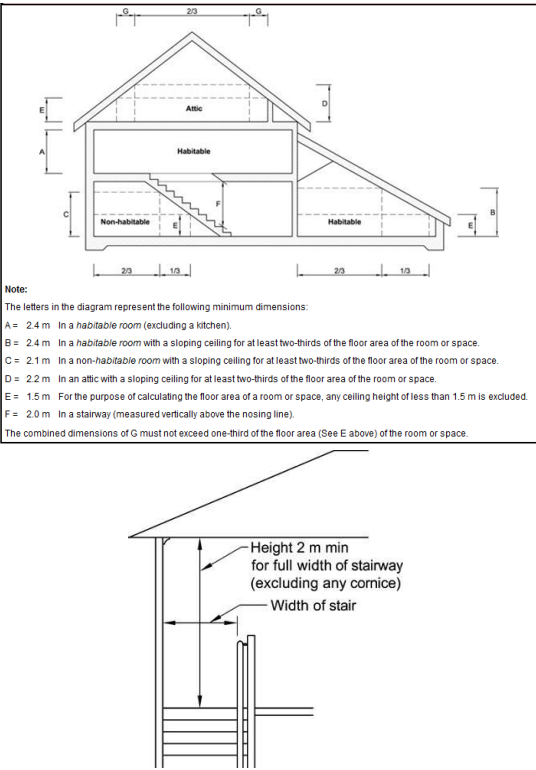
Part F5 – Room heights			
Clause	Description	Status	Comments
F5D1	Deemed-to-Satisfy Provisions	Noted	
F5D2	Height of rooms and other spaces	CRA	Ceiling heights must be not less than—
 <p>Note: The letters in the diagram represent the following minimum dimensions: A = 2.4 m In a habitable room (excluding a kitchen). B = 2.4 m In a habitable room with a sloping ceiling for at least two-thirds of the floor area of the room or space. C = 2.1 m In a non-habitable room with a sloping ceiling for at least two-thirds of the floor area of the room or space. D = 2.2 m In an attic with a sloping ceiling for at least two-thirds of the floor area of the room or space. E = 1.5 m For the purpose of calculating the floor area of a room or space, any ceiling height of less than 1.5 m is excluded. F = 2.0 m In a stairway (measured vertically) above the nosing line. The combined dimensions of G must not exceed one-third of the floor area (See E above) of the room or space.</p>		<p>(1) The height of rooms and other spaces in a Class 2 or 3 building or class 4 part of a building must be not less than —</p> <ul style="list-style-type: none"> (a) for a kitchen, laundry, or the like — 2.1 m; and (b) for a corridor, passageway, or the like — 2.1 m; and (c) for a habitable room excluding a kitchen — 2.4 m; and (d) in habitable room, or space within a habitable room, with a sloping ceiling or projections below the ceiling line— <ul style="list-style-type: none"> (i) in an attic — a height of not less than 2.2 m for at least two-thirds of the floor area of the room or space; and (ii) in other rooms — a height of not less than 2.4 m over two-thirds of the floor area of the room or space; and (e) a habitable room, or space within a habitable room, with a sloping ceiling or projections below the ceiling line — a height of not less than 2.1 m for not less than two-thirds of the floor area of the room or space. <p>(2) For the purposes of (1), when calculating the floor area of a room or space, any part that has a ceiling height of less than 1.5 m is not included; and</p> <p>(3) The height of rooms and other spaces in a Class 5, 6, 7 or 8 building must be not less than—</p> <ul style="list-style-type: none"> (a) except as allowed in (b) and (8) — 2.4 m; and (b) a corridor, passageway, or the like — 2.1 m; and <p>(5) The height of rooms and other spaces in a Class 9b building must be not less than—</p> <ul style="list-style-type: none"> (a) a school classroom or other assembly building or part that accommodates not more than 100 people—2.4m; and (b) a theatre, public hall or other assembly building or part that accommodates more than 100 persons – 2.7m; and (c) a corridor — <ul style="list-style-type: none"> (i) that serves an assembly building or part that accommodates not more than 100 people — 2.4m; (ii) that serves an assembly building or part that accommodates more than 100 persons—2.7m; and <p>(8) in any building—</p>	

Part F5 – Room heights			
Clause	Description	Status	Comments
			<p>(a) a bathroom, shower room, sanitary compartment, airlock, tea preparation room, pantry, store room, garage, car parking area, or the like — 2.1 m; and</p> <p>(b) a commercial kitchen — 2.4 m; and</p> <p>(c) above a stairway, ramp, landing or the like — 2 m measured vertically above the nosing line of stairway treads or the floor surface of the ramp, landing or the like.</p> <p>Designer to verify compliance prior to the issue of the Construction Certificate.</p>

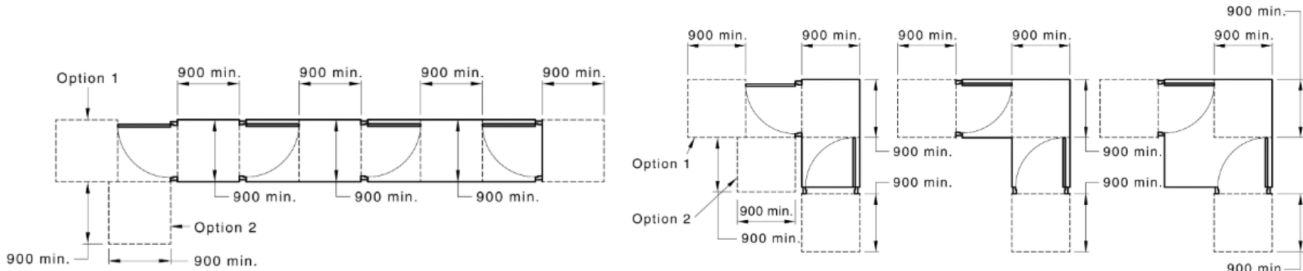

Part F6 – Light and Ventilation			
Clause	Description	Status	Comments
F6D1	Deemed-to-Satisfy Provisions	Noted	
F6D2	Provision of natural light	CRA	Natural light must be provided to all habitable rooms located within the Class 2 portion of the development.
F6D3	Methods and extent of natural light	CRA	<p>Required natural light must be provided by either:</p> <ul style="list-style-type: none"> • Windows, excluding roof lights, that have an aggregate light transmitting area measured exclusive of framing members, glazing bars or other obstructions of not less than 10% of the floor area of the room and are open to the sky or face a court or other space open to the sky or an open verandah, carport or the like; or • Roof lights, that have an aggregate light transmitting area measured exclusive of framing members, glazing bars or other obstructions of not less than 3% of the floor area of the room and are open to the sky; or • Proportional combination of windows and roof lights. <p>Design verification to be provided prior to the issue of the Construction Certificate.</p>
F6D4	Natural light borrowed from adjoining room	CRA	<p>Natural lighting to a room in a Class 2 building or Class 4 part of a building or in a sole-occupancy unit of a Class 3 building, may come through a glazed panel or opening from an adjoining room (including an enclosed verandah).</p> <p>Designer to assess the design of light to all subject bedrooms prior to the issue of the Construction Certificate.</p> <p>Details and design certification for natural light borrowed are to be provided by the architect prior to the issue of a Construction Certificate.</p>
F6D5	Artificial lighting	CRA	<p>Artificial lighting must be provided in required stairways, passageways, ramps, sanitary compartments, bathrooms, laundries and other spaces used in common by occupants of the building complying with AS1680.0 in accordance with the requirements of Clause F6D5 of the BCA.</p> <p>Details and design certification to be provided by electrical engineer prior to the issue of a Construction Certificate.</p>
F6D6	Ventilation of rooms	CRA	<p>Ventilation shall be provided throughout the building by means of natural ventilation complying with Clause F6D7 or mechanical ventilation complying with the requirements of AS1668.2 and AS3666.1 as required by Clause F6D6 of the BCA.</p> <p>Details and design certification to be provided by mechanical engineer prior to the issue of a Construction Certificate.</p> <p><i>Note: Any air handling system which recycles air from one fire compartment to another or operates in a manner that may unduly contribute to the spread of smoke from one compartment to another must be designed to operate a smoke control system in accordance with AS1668.1 or incorporate smoke dampers where the air-handling ducts pass any separating element to another fire compartment and</i></p>

Part F6 – Light and Ventilation			
Clause	Description	Status	Comments
			<i>shutdown and the smoke dampeners are activated to close automatically via smoke detectors complying with clause 4.10 of AS1668.1</i>
F6D7	Natural ventilation	CRA	See Clause F6D6
F6D8	Ventilation borrowed from adjoining room	CRA	See Clause F6D6
F6D9	Restriction on location of sanitary compartments	Complies	
F6D10	Airlocks	Noted	Note: Airlocks must comply with the set distances under AS1428.1 :2021
			
F6D11	Carparks	CRA	The carpark is to be provided with ventilation complying with AS1668.2 or have an adequate system of permanent natural ventilation. Details and design certification to be provided by mechanical engineer prior to the issue of a Construction Certificate.
F6D12	Kitchen local exhaust ventilation	N / A	

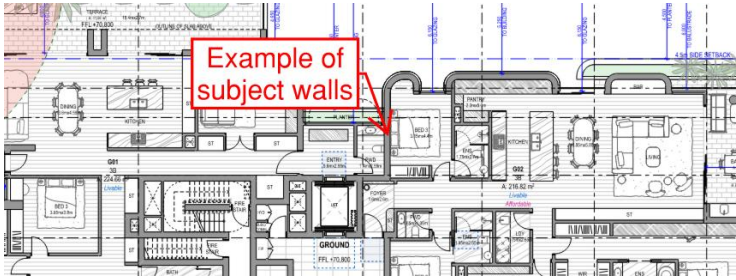
Part F7 – Sound Transmission and Insulation			
Clause	Description	Status	Comments
F7D1	Deemed-to-Satisfy Provisions	Noted	-
F7D2	Application of part	Applies	Applicable to Class 2 buildings
F7D3	Determination of airborne sound insulation ratings	Noted	Construction required to have an airborne sound insulation rating must have the value for weighted sound reduction index (R _w) or weighted sound reduction index with spectrum adaptation term (R _w + C _{tr}) determined in accordance with AS/NZS1276.1, or ISO717.1 using result from laboratory measurements, or comply with Specification 28 of the BCA.
F7D4	Determination of impact sound insulation ratings	CRA	<p>A floor required to have an impact sound insulation rating must have the required value for weighted normalised impact sound pressure level with spectrum adaptation term (L_{n,w+Ci}) determined in accordance with AS/ISO 717.2 using results from laboratory measurements or comply with Specification 28 of the BCA.</p> <p>A wall that is required to have an impact sound insulation rating must be of discontinuous construction. For the purposes of this Part, discontinuous construction means a wall having a minimum 20 mm cavity between 2 separate leaves, and for masonry, where wall ties are required to connect leaves, the ties are of the resilient type. For other than masonry, there is no mechanical linkage between leaves except at the periphery.</p> <p>SOU Walls Bounding SOU Bathrooms</p> <p>Discontinuous construction is required between the habitable rooms of an SOU and the bathroom of an adjoining SOU.</p>  <p>SOU Walls Bounding Mechanical Risers</p> <p>Discontinuous construction is recommended between the internal parts of an SOU and mechanical riser(s).</p>

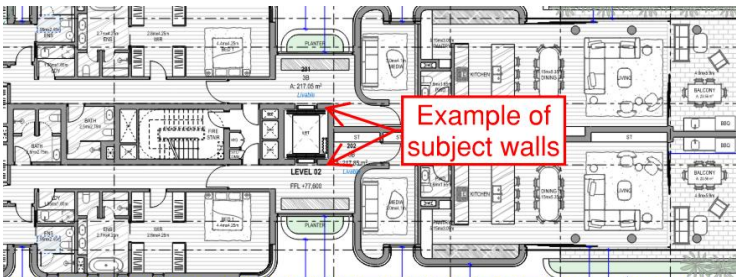
Part F7 – Sound Transmission and Insulation			
Clause	Description	Status	Comments
			 <p>SOU Walls Bounding Lift Shaft</p> <p>Discontinuous construction is required between the lift and the internal parts of the SOU.</p>  <p>Design verification to be provided prior to the issue of the Construction Certificate.</p>
F7D5	Sound insulation rating of floors	CRA	<p>Floors separating sole occupancy units or separating sole occupancy units from a plant room, lift shaft, public lobby or the like or parts of different classifications must have an $R_w + C_{tr}$ of not less than 50 and an $L_{n,w} + C_i$ of not more than 62.</p> <p>A design certificate and details of form of construction required to achieve such will be required from a qualified acoustic engineer prior to the issue of a Construction Certificate.</p>
F7D6	Sound insulation rating of walls	CRA	<p>A wall separating sole occupancy units must have an $R_w + C_{tr}$ not less than 50. A wall separating a sole occupancy from a lift shaft, public lobby or the like, or parts of different classifications must have an $R_w + C_{tr}$ not less than 50.</p> <p>Compliance with F7D4(2) is required if the wall separates a bathroom, sanitary compartment, laundry or kitchen in one sole occupancy unit from a habitable room (excluding a kitchen) in another adjoining unit or a sole occupancy unit from a plant room or lift shaft.</p> <p>A door may be incorporated in a wall that separates a sole occupancy unit from a stairway, public corridor, public lobby or the like, provided the door assembly has an R_w not less than 30.</p> <p>Where a wall required to have sound insulation has a floor above, the wall must continue to the underside of the floor above or a ceiling that provides the sound insulation required for the wall.</p>

Part F7 – Sound Transmission and Insulation			
Clause	Description	Status	Comments
			<p>Where a wall required to have sound insulation has a roof above, the wall must continue to the underside of the roof above or a ceiling that provides the sound insulation required for the wall.</p> <p>A design certificate and details of form of construction required to achieve such will be required from a qualified acoustic engineer prior to the issue of a Construction Certificate.</p>
F7D7	Sound insulation rating of internal services	CRA	<p>If a duct, soil, waste or water supply pipe, including a duct or pipe that is located in a wall or floor cavity, serves or passes through more than one sole-occupancy unit, the duct or pipe must be separated from the rooms of any sole-occupancy unit by construction with an $R_w + C_{tr}$ (airborne) not less than—</p> <ul style="list-style-type: none"> (a) 40 if the adjacent room is a habitable room (other than a kitchen); or (b) 25 if the adjacent room is a kitchen or non-habitable room. <p>If a storm water pipe passes through a sole-occupancy unit it must be separated in accordance with (a) and (b) above.</p> <p>A design certificate and details will be required by a qualified acoustic engineer prior to the issue of a Construction Certificate.</p>
F7D8	Sound isolation of pumps	CRA	<p>A flexible coupling must be used at the point of connection between the service pipes in a building and any circulating or other pump.</p>



Part F8 – Condensation management			
Clause	Description	Status	Comments
F8D1	Deemed-to-Satisfy Provisions	Noted	-
F8D2	Application of Part	Applies	Applicable to a sole-occupancy unit of a Class 2 building or a Class 4 part of a building.
F8D3	External wall construction	CRA	<p>(1) Where a pliable building membrane is installed in an external wall, it must—</p> <ul style="list-style-type: none"> (a) comply with AS/NZS 4200.1; and (b) be installed in accordance with AS 4200.2; and (c) be located on the exterior side of the primary insulation layer of wall assemblies that form the external envelope of a building. <p>(2) Where a pliable building membrane, sarking-type material or insulation layer is installed on the exterior side of the primary insulation layer of an external wall it must have a vapour permeance of not less than—</p> <ul style="list-style-type: none"> (a) in climate zones 4 and 5, 143 µg/N.s; and (b) in climate zones 6,7 and 8, 1.14 µg/N.s. <p>(3) Except for single skin masonry and single skin concrete, where a pliable building membrane is not installed in an external wall, the primary water control layer must be separated from water sensitive materials by a drained cavity.</p> <p>Details and a design certificate to be provided prior to the issue of a Construction Certificate.</p>
F8D4	Exhaust systems	CRA	<p>(1) An exhaust system installed in a kitchen, bathroom, sanitary compartment or laundry must have a minimum flow rate of—</p> <ul style="list-style-type: none"> (a) 25 L/s for a bathroom or sanitary compartment; and (b) 40 L/s for a kitchen or laundry. <p>(2) Exhaust from a kitchen, kitchen range hood, bathroom, sanitary compartment or laundry must be discharged directly or via a shaft or duct to outdoor air.</p> <p>(3) Where space for a clothes drying appliance is provided in accordance with F4D2(1)(B), space must also be provided for ducting from the clothes drying appliance to outdoor air.</p> <p>(4) (3) does not apply if a condensing-type clothes drying appliance is installed.</p> <p>(5) An exhaust system that is not run continuously and is serving a bathroom or sanitary compartment that is not ventilated in accordance with F6D7 must-</p> <ul style="list-style-type: none"> (a) be interlocked with the room's light switch; and (b) include a run-on timer so that the exhaust system continues to operate for 10 minutes after the light switch is turned off. <p>(6) Except for rooms that are ventilated in accordance with F6D7, a room with space for ducting a clothes drying appliance to outdoor air in</p>



Part F8 – Condensation management			
Clause	Description	Status	Comments
			accordance with (3) must be provided with make-up air in accordance with AS 1668.2. Details and design certification to be provided by mechanical engineer prior to the issue of a Construction Certificate.
F8D5	Ventilation of roof spaces	CRA	(1) In climate zones 6, 7 and 8, a roof must have a roof space that— (a) is located— (i) immediately above the primary insulation layer, or (ii) immediately above sarking with a vapour permeance of not less than 1.14 µg/N.s, which is immediately above the primary insulation layer, or (iii) immediately above ceiling insulation which meets the requirements of J3D7(3) and J3D7(4); and (b) has a height of not less than 20 mm; and (c) is either— (i) ventilated to outdoor air through evenly distributed openings in accordance with Table F8D5; or (ii) located immediately underneath roof tiles of an unsarked tiled roof. (2) The requirements of (1) do not apply to— (a) concrete roof; or (b) roof that is made of structural insulated panels; or (c) roof that is subject to Bushfire Attack Level FZ requirements in accordance with AS 3959. Details and design certification to be provided by mechanical engineer prior to the issue of a Construction Certificate.

SECTION G – ANCILLARY PROVISIONS

Part G1 – Minor Structures and Components			
Clause	Description	Status	Comments
G1D1	Deemed-to-Satisfy Provisions	Noted	
G1D2 & NSW G1D2	Swimming pools	CRA	This development includes a swimming pool. Note: Requirements for the Class 10b pool fall outside the scope of this BCA review. Please ensure NSW pool regulations are assessed by a suitably qualified consultant
G1D3	Refrigerated chambers, strong-rooms and vaults	N / A	
G1D4	Outdoor play spaces	N / A	
NSW G1D5	Provision for cleaning windows	CRA	A safe manner of cleaning windows is to be provided as windows are located 3 or more storeys above ground level. The windows must either be able to be cleaned wholly from within the building, or a method complying with the Construction Safety Act 1912 and Regulations is required. Details verifying compliance must be provided prior to the issue of a Construction Certificate

Part G2 – Boilers, pressure vessels, heating appliances, fireplaces, chimneys and flues

N / A

Part G3 – Atrium construction

N / A

Part G4 – Construction in alpine areas

N / A

Part G5 – Construction in bushfire prone areas

N / A

Part G6 – Occupiable outdoor areas			
Clause	Description	Status	Comments
G6D1	Application of Part	Noted	<p>(1) The Deemed-to-Satisfy Provisions of this Part apply to buildings containing an occupiable outdoor area in addition to the other Deemed-to-Satisfy Provisions of NCC Volume One..</p> <p>(2) The Deemed-to-Satisfy Provisions of this Part take precedence where there is a difference to the Deemed-to-Satisfy Provision of Sections C, D, E, F and G.</p> <p>(3) Except for G6D2, the Deemed-to-Satisfy Provisions of this Part do not apply to-</p> <ul style="list-style-type: none"> (a) An occupiable outdoor area of a sole-occupancy unit in a Class 2 or 3 Building, Class 9c building or Class 4 part of a building; or (b) An occupiable outdoor area with an area less than 10m².
G6D2	Fire hazard properties	CRA	<p>(1) Subject to (2), a lining, material or assembly in an occupiable outdoor area must comply with C2D11 as for an internal element</p> <p>(2) The following fire hazard properties of a lining, material or assembly in an occupiable outdoor area are not required to comply with C2D11:</p> <ul style="list-style-type: none"> (a) Average specific extinction area. (b) Smoke-Developed Index. (c) Smoke development rate. (d) Smoke growth rate index (SMOGRA RC) <p>Design certification will be required verifying compliance prior to the issue of a Construction Certificate.</p>
G6D3	Fire separation	CRA	<p>For the purposes of the Deemed-to-Satisfy Provisions of C3D8, C3D9, and C3D10, a reference to a storey includes an occupiable outdoor area, however a fire wall cannot be used to separate an occupiable outdoor area into different fire compartments.</p> <p>Design certification will be required verifying compliance prior to the issue of a Construction Certificate.</p>
G6D4	Provision for escape	CRA	<p>For the purposes of the Deemed-to-Satisfy Provisions of Part D2, a reference to a storey or room includes an occupiable outdoor area.</p> <p>Design certification will be required verifying compliance prior to the issue of a Construction Certificate.</p>
G6D5	Construction of exits	CRA	<p>For the purposes of the Deemed-to-Satisfy Provisions of Part D3, a reference to a storey or room includes an occupiable outdoor area.</p> <p>Design certification will be required verifying compliance prior to the issue of a Construction Certificate.</p>
G6D6	Fire fighting equipment	CRA	<p>Except for S17C7(2)(a), for the purposes of the Deemed-to-Satisfy Provisions of Part E1, a reference to a storey includes an occupiable outdoor area.</p> <p>Design certification will be required verifying compliance prior to the issue of a Construction Certificate.</p>

Part G6 – Occupiable outdoor areas			
Clause	Description	Status	Comments
G6D7	Lift Installations	CRA	For the purposes of the Deemed-to-Satisfy Provisions of Part E3, a reference to a storey includes an occupiable outdoor area. Design certification will be required verifying compliance prior to the issue of a Construction Certificate.
G6D8	Visibility in an emergency, exit signs and warning systems	CRA	For the purposes of the Deemed-to-Satisfy Provisions of Part E4, a reference to a storey includes an occupiable outdoor area. Design certification will be required verifying compliance prior to the issue of a Construction Certificate.
G6D9	Light and ventilation	CRA	For the purposes of the Deemed-to-Satisfy Provisions of F6D5, F6D9 and F6D10, a reference to a room includes an occupiable outdoor area. Design certification will be required verifying compliance prior to the issue of a Construction Certificate.
G6D10	Fire orders	CRA	For the purposes of the Deemed-to-Satisfy Provisions of G4D8, a reference to a storey includes an occupiable outdoor area. Design certification will be required verifying compliance prior to the issue of a Construction Certificate.

Part G7 – Livable housing design
This Part is not applicable to NSW.



SECTION I – SPECIAL USE BUILDINGS

Part I1 – Class 9b Buildings			
Clause	Description	Status	Comments
I1D1	Application of Part	Noted	<p>(1) The Deemed-to-Satisfy Provisions of this Part apply to every enclosed Class 9b building or part of a building which-</p> <ul style="list-style-type: none"> (a) is a school assembly, church or community hall with a stage and any backstage area with at total floor area of more than 300m² ; or (b) Otherwise, has a stage and any backstage area with a total floor area of more than 200m²; or (c) Has a stage with an associated rigging loft. <p>(2) Notwithstanding (1)-</p> <ul style="list-style-type: none"> (a) I1D4 applies to every open or enclosed Class 9b building; and (b) I1D7 applies to every enclosed Class 9b building.
I1D2	Separation	CRA	<p>A theatre, public hall or the link must-</p> <ul style="list-style-type: none"> (a) Have a sprinkler system (other than a FPAA101D or FPAA101H system) complying with Specification 17; or (b) Have the sage, backstage area and accessible under stage area separated from the audience by a proscenium wall in accordance with I1D3. <p>Details and design certification to be provided prior to the issue of a Construction Certificate.</p>
I1D3	Proscenium wall construction	N / A	<p>A proscenium wall must comply with Specification 32.</p> <p>Details and design certification to be provided prior to the issue of a Construction Certificate.</p>
I1D4	Seating area	CRA	<p>In a seating area-</p> <ul style="list-style-type: none"> (a) The gradient of the floor surface must not be steeper than 1 in 8, or the floor must be stepped so that- <ul style="list-style-type: none"> (i) A line joining the nosing of consecutive steps does not exceed an angle of 30° to the horizontal; and (ii) The height of each step in the steeped floor is not more than 600mm; and (iii) The height of any opening in such a step is not more than 125mm; and (b) If an aisle divides the stepped floor and the difference in level between any 2 consecutive steps- <ul style="list-style-type: none"> (i) Exceeds 230mm but not 400mm – an intermediate step must be provided in the aisle; and (ii) Exceeds 400mm – 2 equally spaced intermediate steps must be provided in the aisle; and



Part I1 – Class 9b Buildings			
Clause	Description	Status	Comments
			<p>(iii) The going of intermediate steps must be not less than 270mm and such as to provide as nearly as practicable equal treads throughout the length of the aisle; and</p> <p>(c) The clearance between rows of fixed seats used for viewing performing arts, sport or recreational activities must be not less than-</p> <p>(i) 300mm if the distance to an aisle is not more than 3.5m; or</p> <p>(ii) 500mm if the distance to an aisle is more than 3.5m.</p> <p>Details and design certification to be provided prior to the issue of a Construction Certificate.</p>
I1D5	Exits from stages	CRA	<p>(1) The path of travel to an exit from a stage or performing area must not pass through the proscenium wall if the stage area is separated from the audience area with a proscenium wall</p> <p>(2) Required exits from backstage and under-stage areas must be independent of those provided for the audience area</p> <p>Details and design certification to be provided prior to the issue of a Construction Certificate.</p>
I1D6	Access to platforms and lofts	CRA	<p>A stairway that provides access to a service platform, rigging loft, or the like, must comply with AS 1657.</p> <p>Details and design certification to be provided prior to the issue of a Construction Certificate.</p>
I1D7	Aisle lights	CRA	<p>In every enclosed Class 9b building, where in any part of the auditorium, the general lighting is dimmed or extinguished during public occupation and the floor is stepped or is inclined at a slope steeper than 1 in 12, aisle light must be provided to illuminate the full length of the aisle and tread of each step.</p> <p>Details and design certification to be provided prior to the issue of a Construction Certificate.</p>

SECTION J – ENERGY EFFICIENCY

A detailed assessment of Section J of the BCA is beyond the scope of this report.



4.0. CONCLUSION

Although demonstrating compliance with the BCA at SSDA assessment stage is not a prescribed head of consideration under Section 4.15 (formally Section 79C) of the Environmental Planning & Assessment Act 1979, the consent authority has an obligation to consider whether the proposal, as lodged, is indicatively capable of complying with the BCA - without significant modification to those plans for which approval is sought.

In this instance we are confident that any modifications and advancement in level of details required to the proposal in order to satisfy the requirements of the BCA (in force at the time the Construction Certificate application is lodged) will not necessitate the need for any significant design changes that in turn would necessitate the submission of an application under Section 4.55 (formally Section 96) of the Environmental Planning and Assessment Act 1979.

In the same regard, we draw the Department of Planning, Housing and Infrastructure's (DPHI) attention to the requirements of Section 19 of the Environmental Planning & Assessment (Development Certification and Fire Safety) Regulation 2021, and suggest that detailed & specific BCA compliance matters shall be addressed to the satisfaction of the appointed Certifying Authority prior to the issue of the Construction Certificate.

Further, it is considered that this BCA review and the additional preparation of the required Construction Certificate documentation will be sufficient to ensure that the proposed design will achieve the necessary compliance with the BCA.

PREPARED BY:

Jennifer Lee
Access Consultant
Building Innovations Australia Pty Ltd
Dip.Access (Diploma of Access Consulting)

ASSESSED BY:

Mardiros Tatian
Director
Building Innovations Australia Pty Ltd
M.Fire.Eng (Master of Fire Engineering)
Grad.Dip.Bld.Survey (Graduate Diploma of Building Surveying)
B.Med.Sci (Bachelor of Medical Science)
Building Professionals Board, NSW- A1 Accredited Certifier BPB 2572



APPENDIX A – FIRE RESISTANCE LEVELS (TYPE A CONSTRUCTION)

Table S5C11a: TYPE A CONSTRUCTION: FRL OF LOADBEARING PARTS OF EXTERNAL WALLS

Distance from a <i>fire-source feature</i>	FRL (in minutes): <i>Structural adequacy / Integrity / Insulation</i>			
	Class 2, 3 or 4 part	Class 5, 7a or 9	Class 6	Class 7b or 8
Less than 1.5 m	90/90/90	120/120/120	180/180/180	240/240/240
1.5 to less than 3 m	90/60/60	120/90/90	180/180/120	240/240/180
3 m or more	90/60/30	120/60/30	180/120/90	240/180/90

Table S5C11b: TYPE A CONSTRUCTION: FRL OF NON-LOADBEARING PARTS OF EXTERNAL WALLS

Distance from a <i>fire-source feature</i>	FRL (in minutes): <i>Structural adequacy / Integrity / Insulation</i>			
	Class 2, 3 or 4 part	Class 5, 7a or 9	Class 6	Class 7b or 8
Less than 1.5 m	-/90/90	-/120/120	-/180/180	-/240/240
1.5 to less than 3 m	-/60/60	-/90/90	-/180/120	-/240/180
3 m or more	-/-/-	-/-/-	-/-/-	-/-/-

Table S5C11c: TYPE A CONSTRUCTION: FRL OF EXTERNAL COLUMNS NOT INCORPORATED IN AN EXTERNAL WALL

Column type	FRL (in minutes): <i>Structural adequacy / Integrity / Insulation</i>			
	Class 2, 3 or 4 part	Class 5, 7a or 9	Class 6	Class 7b or 8
<i>Loadbearing</i>	90/-/-	120/-/-	180/-/-	240/-/-
<i>Non-loadbearing</i>	-/-/-	-/-/-	-/-/-	-/-/-

Table S5C11d: TYPE A CONSTRUCTION: FRL OF COMMON WALLS AND FIRE WALLS

Wall type	FRL (in minutes): <i>Structural adequacy / Integrity / Insulation</i>			
	Class 2, 3 or 4 part	Class 5, 7a or 9	Class 6	Class 7b or 8
<i>Loadbearing or non-loadbearing</i>	90/90/90	120/120/120	180/180/180	240/240/240



Table S5C11e: TYPE A CONSTRUCTION: FRL OF LOADBEARING INTERNAL WALLS

Location	FRL (in minutes): <i>Structural adequacy / Integrity / Insulation</i>			
	Class 2, 3 or 4 part	Class 5, 7a or 9	Class 6	Class 7b or 8
<i>Fire-resisting lift and stair shafts</i>	90/90/90	120/120/120	180/120/120	240/120/120
Bounding <i>public corridors</i> , public lobbies and the like	90/90/90	120/-/-	180/-/-	240/-/-
Between or bounding <i>sole-occupancy units</i>	90/90/90	120/-/-	180/-/-	240/-/-
Ventilating, pipe, garbage, and like <i>shafts</i> not used for the discharge of hot products of combustion	90/90/90	120/90/90	180/120/120	240/120/120

Table S5C11f: TYPE A CONSTRUCTION: FRL OF NON-LOADBEARING INTERNAL WALLS

Location	FRL (in minutes): <i>Structural adequacy / Integrity / Insulation</i>			
	Class 2, 3 or 4 part	Class 5, 7a or 9	Class 6	Class 7b or 8
<i>Fire-resisting lift and stair shafts</i>	-/90/90	-/120/120	-/120/120	-/120/120
Bounding <i>public corridors</i> , public lobbies and the like	-/60/60	-/-/-	-/-/-	-/-/-
Between or bounding <i>sole-occupancy units</i>	-/60/60	-/-/-	-/-/-	-/-/-
Ventilating, pipe, garbage, and like <i>shafts</i> not used for the discharge of hot products of combustion	-/90/90	-/90/90	-/120/120	-/120/120

Table S5C11g: TYPE A CONSTRUCTION: FRL OF OTHER BUILDING ELEMENTS NOT COVERED BY TABLES S5C11a to S5C11f

Building element	FRL (in minutes): <i>Structural adequacy / Integrity / Insulation</i>			
	Class 2, 3 or 4 part	Class 5, 7a or 9	Class 6	Class 7b or 8
Other <i>loadbearing</i> internal walls, internal beams, trusses and columns	90/-/-	120/-/-	180/-/-	240/-/-
Floors	90/90/90	120/120/120	180/180/180	240/240/240
Roofs	90/60/30	120/60/30	180/60/30	240/90/60

Note: Under Specification 5, there are many individual additional requirements and concessions which need to be assessed and read in conjunction with this Specification. Your engineer is to confirm compliance with all required Fire Rated Elements.

General Requirements:

- Exposure to Fire-source features
- Fire Protection for a supporting of another part
- Lintels
- Attachments not to impair fire-resistance
- General concessions



Fire-resistance of building elements:

In a building required to be of Type A construction

- (a) each building element listed in Tables S5C11a-S5C11g and any beam or column incorporated in it, must have an FRL not less than that listed in the Tables for the particular Class of building concerned; and*
- (b) external walls, common walls and the flooring and floor framing of lift pits must be non-combustible; and*
- (c) any internal wall required to have an FRL with respect to integrity and insulation must extend to;
 - (i) the underside of the floor next above; or*
 - (ii) the underside of a roof complying with Tables S5C11a-S5C11g; or*
 - (iii) if under Clause 3.5 the roof is not required to comply with Tables S5C11a-S5C11g, the underside of the non-combustible roof covering and, except for roof battens with dimensions of 75 mm x 50 mm or less or sarking-type material, must not be crossed by timber or other combustible building elements; or*
 - (iv) a ceiling that is immediately below the roof and has a resistance to the incipient spread of fire to the roof space between the ceiling and the roof of not less than 60 minutes; and**
- (d) a loadbearing internal wall and a loadbearing fire wall (including those that are part of a loadbearing shaft) must be of concrete or masonry; and*
- (e) a non-loadbearing
 - (i) internal wall required to be fire-resisting; and*
 - (ii) lift, ventilating, pipe, garbage, or similar shaft that is not for the discharge of hot products of combustion, must be of non-combustible construction; and**
- (f) the FRLs specified in Tables S5C11a-S5C11g for an external column apply also to those parts of an internal column that face and are within 1.5 m of a window and are exposed through that window to a fire-source feature.*

APPENDIX B – SCHEDULE 2: REFERENCED DOCUMENTS

Table 1 SCHEDULE OF REFERENCED DOCUMENTS

No.	Date	Title	Volume One	Volume Two	Housing Provisions	Volume Three
AS/NZS ISO 717 Part 1	2004	Acoustics — Rating of sound insulation in buildings and of building elements — Airborne sound insulation. (See Note 1)	F7V1, F7V2, F7V3, F7V4, F7D3	H4V4	10.7.2	N/A
AS ISO 717 Part 2	2004	Acoustics — Rating of sound insulation in buildings and of building elements — Impact sound insulation	F7V1, F7V3, F7D4	N/A	N/A	N/A
AS 1056 Part 1	1991	Storage water heaters — General requirements (incorporating amendments 1, 2, 3, 4 and 5)	N/A	N/A	N/A	B2D2
AS/NZS 1170 Part 0	2002	Structural design actions — General principles (incorporating amendments 1, 3 and 4)	B1V1, B1D2, Spec 4	H1V1, H1D7	2.2.2	N/A
AS/NZS 1170 Part 1	2002	Structural design actions — Permanent, imposed and other actions (incorporating amendments 1 and 2)	B1D3	N/A	2.2.3, 2.2.4, 8.3.1, 11.2.2, 11.2.3, 11.3.4	N/A
AS/NZS 1170 Part 2	2021	Structural design actions — Wind actions	B1D3, B1D4, Spec 4, F3V1, Schedule 1	H1D7, H2V1, Schedule 1	2.2.3, Schedule 1	Schedule 1
AS/NZS 1170 Part 3	2003	Structural design actions — Snow and ice actions (incorporating amendments 1 and 2)	B1D3	N/A	2.2.3	
AS 1170 Part 4	2007	Structural design actions — Earthquake actions in Australia (incorporating amendments 1 and 2)	B1D3	H1D4, H1D5, H1D6, H1D9	2.2.3	N/A
AS 1191	2002	Acoustics — Method for laboratory measurement of airborne sound transmission insulation of building elements	Spec 29	N/A	N/A	N/A
AS 1273	1991	Unplasticized PVC (UPVC) downpipe and fittings for rainwater	N/A	N/A	7.4.2	N/A
AS 1288	2021	Glass in buildings — Selection and installation	B1D4, Spec 11, Spec 12	H1D8	8.3.1	N/A
AS 1289.6.3.3	1997	Methods of testing soils for engineering purposes — Method 6.3.3: Soil strength and consolidation tests — Determination of the penetration resistance of a soil — Perth sand penetrometer test (incorporating amendment 1)	N/A	N/A	4.2.4	N/A
No.	Date	Title	Volume One	Volume Two	Housing Provisions	Volume Three
AS 1397	2021	Continuous hot-dip metallic coated steel sheet and strip — Coatings of zinc and zinc alloyed with aluminium and magnesium (See Note 10)	N/A	N/A	7.2.2	N/A
AS 1428 Part 1	2009	Design for access and mobility — General requirements for access — New building work (incorporating amendments 1 and 2)	D3D11, D3D16, D3D22, D4D2, D4D3, D4D4, D4D7, D4D10, D4D11, D4D13, Spec 16, E3D10, F4D5, G4D5, Schedule 1	Schedule 1	Schedule 1	Schedule 1, E1D2
AS 1428 Part 1	2001	Design for access and mobility — General requirements for access — New building work	I2D7, I2D8, I2D10, I2D15	N/A	N/A	E1D2
AS 1428 Part 1 (Supplement 1)	1993	Design for access and mobility — General requirements for access — Buildings — Commentary	I2D2	N/A	N/A	N/A
AS 1428 Part 2	1992	Design for access and mobility — Enhanced and additional requirements — Buildings and facilities	I2D2, I2D3, I2D4, I2D5, I2D7, I2D10, I2D11, I2D12, I2D13, I2D14	N/A	N/A	E1D2
AS 1428 Part 4	1992	Design for access and mobility — Tactile ground surface indicators for the orientation of people with vision impairment	I2D11	N/A	N/A	N/A
AS/NZS 1428 Part 4.1	2009	Design for access and mobility — Means to assist the orientation of people with vision impairment — Tactile ground surface indicators (incorporating amendments 1 and 2)	D4D9	N/A	N/A	N/A
AS 1530 Part 1	1994	Methods for fire tests on building materials, components and structures — Combustibility test for materials	Schedule 1	Schedule 1	Schedule 1	Schedule 1
AS 1530 Part 2	1993	Methods for fire tests on building materials, components and structures — Test for flammability of materials (incorporating amendment 1)	Schedule 1	Schedule 1	Schedule 1	Schedule 1



No.	Date	Title	Volume One	Volume Two	Housing Provisions	Volume Three
AS/NZS 1530 Part 3	1999	Methods for fire tests on building materials, components and structures — Simultaneous determination of ignitability, flame propagation, heat release and smoke release	Schedule 1, Spec 3	Schedule 1, Spec 3	Schedule 1	Schedule 1, Spec 3
AS 1530 Part 4	2014	Methods for fire tests on building materials, components and structures — Fire resistance tests for elements of construction	C4D15, C4D16, Spec 9, Spec 10, Spec 13, Spec 14, Schedule 1, Spec 3	9.3.2, Schedule 1, Spec 3	Schedule 1	Schedule 1, Spec 3
AS 1530 Part 8.1	2018	Methods for fire tests on building materials, components and structures — Tests on elements of construction for buildings exposed to simulated bushfire attack — Radiant heat and small flaming sources	Spec 43	N/A	N/A	N/A
AS/NZS 1546 Part 1	2008	On-site domestic wastewater treatment units - Septic tanks	N/A	N/A	N/A	C3D2
AS/NZS 1546 Part 2	2008	On-site domestic wastewater treatment units - Waterless composting toilets	N/A	N/A	N/A	C3D3
AS 1546 Part 3	2017	On-site domestic wastewater treatment units - Secondary treatment systems (incorporating amendment 1)	N/A	N/A	N/A	C3D4
AS 1546 Part 4	2016	On-site domestic wastewater treatment units - Domestic greywater treatment systems	N/A	N/A	N/A	C3D5
AS/NZS 1547	2012	On-site domestic wastewater management	N/A	N/A	N/A	C3D6
AS 1562 Part 1	2018	Design and installation of sheet roof and wall cladding — Metal (See Note 2)	B1D4, F3D2, F3D5	H1D7	N/A	N/A
AS1562 Part 3	2006	Design and installation of sheet roof and wall cladding — Plastic	B1D4, F3D2	H1D7	N/A	N/A
AS 1657	2018	Fixed platforms, walkways, stairways and ladders — Design, construction and installation	D2D21, D2D22, D3D23, I1D6, I3D5	N/A	N/A	N/A
AS/NZS 1664 Part 1	1997	Aluminium structures — Limit state design (incorporating amendment 1)	B1D4	N/A	2.2.4	N/A
AS/NZS 1664 Part 2	1997	Aluminium structures — Allowable stress design (incorporating amendment 1)	B1D4	N/A	2.2.4	N/A
No.	Date	Title	Volume One	Volume Two	Housing Provisions	Volume Three
AS 1668 Part 1	2015	The use of ventilation and air conditioning in buildings — Fire and smoke control in buildings (incorporating amendment 1)	C3D13, C4D15, Spec 11, D2D12, Spec 19, E2D3, E2D4, E2D6, E2D7, E2D8, E2D9, E2D11, E2D12, E2D13, E2D16, E2D17, E2D19, F6D12, Spec 21, Spec 31	N/A	N/A	N/A
AS 1668 Part 2	2012	The use of ventilation and air conditioning in buildings — Mechanical ventilation in buildings (incorporating amendments 1 and 2)	E2D12, F6V1, F6D6, F6D11, F6D12, F8D4, J6D4	H4V3, H4D7	10.8.2	N/A
AS 1668 Part 4	2012	The use of ventilation and air conditioning in buildings — Natural ventilation of buildings	F6D11	N/A	N/A	N/A
AS 1670 Part 1	2018	Fire detection, warning, control and intercom systems — System design, installation and commissioning — Fire (incorporating amendment 1) (See Note 3)	C4D6, C4D7, C4D8, C4D9, C4D12, D3D26, E2D3, E2D10, G4D7, Spec 12, Spec 20, Spec 23, Spec 31	N/A	9.5.1	N/A
AS 1670 Part 3	2018	Fire detection, warning, control and intercom systems — System design, installation and commissioning — Fire alarm monitoring (incorporating amendment 1) (See Note 3)	Spec 20, Spec 23	N/A	N/A	N/A
AS 1670 Part 4	2018	Fire detection, warning, control and intercom systems — System design, installation and commissioning — Emergency warning and intercom systems (incorporating amendment 1) (See Note 3)	E3V2, E4D9, Spec 31	N/A	N/A	N/A
AS/NZS 1680 Part 0	2009	Interior lighting — Safe movement	F6D5	N/A	10.5.2	N/A
AS 1684 Part 2	2021	Residential timber-framed construction — Non-cyclonic areas	B1D4, B1D5, F1D8	H1D6	2.2.5, 4.2.13, 5.6.6, 6.2.1, 6.3.6, 7.5.2, 7.5.3, 7.5.4, 10.2.19, 10.2.20	N/A



No.	Date	Title	Volume One	Volume Two	Housing Provisions	Volume Three
AS 1684 Part 3	2021	Residential timber-framed construction — Cyclonic areas	B1D4, B1D5, F1D8	H1D6	2.2.5, 4.2.13, 5.6.6, 6.2.1, 6.3.6, 7.5.2, 7.5.3, 7.5.4, 10.2.19, 10.2.20	N/A
AS 1684 Part 4	2010	Residential timber-framed construction — Simplified — Non-cyclonic areas (incorporating amendment 1)	B1D4, B1D5, F1D8	H1D6	2.2.5, 4.2.13, 5.6.6, 6.2.1, 7.5.2, 7.5.3, 7.5.4, 10.2.19, 10.2.20	N/A
AS 1720 Part 1	2010	Timber structures — Design methods (incorporating amendments 1, 2 and 3)	B1V1, B1D4	H1V1, H1D6	4.2.13, 5.3.3	N/A
AS/NZS 1720 Part 4	2019	Timber structures — Fire resistance of timber elements	Spec 1	Spec 1	N/A	Spec 1
AS 1720 Part 5	2015	Timber structures — Nailplated timber roof trusses (incorporating amendment 1)	B1D4	H1D6	N/A	N/A
AS 1735 Part 11	1986	Lifts, escalators and moving walks — Fire rated landing doors	C4D11	N/A	N/A	N/A
AS 1735 Part 12	1999	Lifts, escalators and moving walks — Facilities for persons with disabilities (incorporating amendment 1)	E3D8, I2D6	N/A	N/A	N/A
AS/NZS 1859 Part 4	2018	Reconstituted wood based panels — Specifications — Wet process fibreboard	N/A	N/A	7.5.3, 7.5.4	N/A
AS 1860 Part 2	2006	Particleboard flooring — Installation (incorporating amendment 1)	B1D4	H1D6	N/A	N/A
AS 1905 Part 1	2015	Components for the protection of openings in fire-resistant walls — Fire-resistant doorsets (incorporating amendment 1)	C4D7, Spec 12	N/A	N/A	N/A
AS 1905 Part 2	2005	Components for the protection of openings in fire-resistant walls — Fire-resistant roller shutters	Spec 12	N/A	N/A	N/A
AS 1926 Part 1	2012	Swimming pool safety — Safety barriers for swimming pools	G1D2, G1D4	H7D2	N/A	N/A
AS 1926 Part 2	2007	Swimming pool safety — Location of safety barriers for swimming pools (incorporating amendments 1 and 2)	G1D2	H7D2	N/A	N/A
AS 1926 Part 3	2010	Swimming pool safety — Water recirculation systems (incorporating amendment 1)	G1D2	H7D2	N/A	N/A
No.	Date	Title	Volume One	Volume Two	Housing Provisions	Volume Three
AS 2047	2014	Windows and external glazed doors in buildings (incorporating amendments 1 and 2) (See Note 4)	B1D4, F3V1, F3D4, J5D5	H1D8, H2V1	13.4.4	N/A
AS 2049	2002	Roof tiles (incorporating amendment 1)	F3D2	H1D7	N/A	N/A
AS 2050	2018	Installation of roof tiles	B1D4, F3D2	H1D7	7.3.2	N/A
AS 2118 Part 1	2017	Automatic fire sprinkler systems — General systems (incorporating amendments 1 and 2)	C1V3, Spec 17, Spec 18	N/A	N/A	N/A
AS 2118 Part 4	2012	Automatic fire sprinkler systems — Sprinkler protection for accommodation buildings not exceeding four storeys in height	Spec 17, Spec 18	N/A	N/A	B4D3
AS 2118 Part 5	2008 (R 2020)	Automatic fire sprinkler systems - Home fire sprinkler systems	N/A	N/A	N/A	B4D3
AS 2118 Part 6	2012	Automatic fire sprinkler systems — Combined sprinkler and hydrant systems in multistorey buildings	Spec 17	N/A	N/A	B4D3
AS 2159	2009	Piling — Design and installation (incorporating amendment 1)	B1D4	H1D12	N/A	N/A
AS/NZS 2179 Part 1	2014	Specifications for rainwater goods, accessories and fasteners — Metal shape or sheet rainwater goods, and metal accessories and fasteners	N/A	N/A	7.4.2	N/A
AS/NZS 2269 Part 0	2012	Plywood — Structural — Specifications (incorporating amendment 1)	N/A	N/A	7.5.4	N/A
AS/NZS 2293 Part 1	2018	Emergency lighting and exit signs for buildings — System design, installation and operation (incorporating amendment 1)	E4D4, E4D8, Spec 25, I3D15	N/A	N/A	N/A
AS 2312 Part 1	2014	Guide to the protection of structural steel against atmospheric corrosion by the use of protective coatings — Paint coatings	N/A	N/A	6.3.9	N/A
AS/NZS 2312 Part 2	2014	Guide to the protection of structural steel against atmospheric corrosion by the use of protective coatings — Hot dip galvanizing	N/A	N/A	6.3.9	N/A
AS/NZS 2327	2017	Composite structures — Composite steel-concrete construction in buildings (incorporating amendment 1)	B1D4, Spec 1	Spec 1	2.2.4	Spec 1



No.	Date	Title	Volume One	Volume Two	Housing Provisions	Volume Three
AS 2419 Part 1	2021	Fire hydrant installations — System design, installation and commissioning	C3D13, E1D2, Spec 18, I3D9	N/A	N/A	B4D4
AS 2441	2005	Installation of fire hose reels (incorporating amendment 1)	E1D3	N/A	N/A	B4D5
AS 2444	2001	Portable fire extinguishers and fire blankets — Selection and location	E1D14, I3D11	N/A	N/A	N/A
AS 2665	2001	Smoke/heat venting systems — Design, installation and commissioning	Spec 22, Spec 31	N/A	N/A	N/A
AS 2699 Part 1	2020	Built-in components for masonry construction — Wall ties (See Note 9)	C2D10	N/A	5.6.5	N/A
AS 2699 Part 3	2020	Built-in components for masonry construction — Lintels and shelf angles (durability requirements) (See Note 9)	C2D10	N/A	5.6.7	N/A
AS 2870	2011	Residential slabs and footings	F1D7	H1D4, H1D5	3.4.2, 4.2.2, 4.2.6, 4.2.8, 4.2.11, 4.2.14, 4.2.15, 10.2.9	N/A
AS/NZS 2890 Part 6	2009	Parking facilities — Offstreet parking for people with disabilities	D4D6	N/A	N/A	N/A
AS/NZS 2904	1995	Damp-proof courses and flashings (incorporating amendments 1 and 2)	F1D6	N/A	5.7.3, 7.5.6, 12.3.3	N/A
AS/NZS 2908 Part 1	2000	Cellulose-cement products — Corrugated sheets	B1D4	N/A	N/A	N/A
AS/NZS 2908 Part 2	2000	Cellulose-cement products — Flat sheets	Schedule 1	Schedule 1	7.5.3, 7.5.4, 7.5.5, 10.2.9, 10.2.10, Schedule 1	Schedule 1
AS/NZS 2918	2018	Domestic solid fuel burning appliances — Installation (See Note 8)	G2D2	H7D5	12.4.4, 12.4.5	N/A
AS/NZS 3013	2005	Electrical installations — Classification of the fire and mechanical performance of wiring system elements	C3D14	N/A	N/A	N/A
AS/NZS 3500 Part 0	2021	Plumbing and drainage — Glossary of terms	A1G4	A1G4	N/A	A1G4
AS/NZS 3500 Part 1	2018	Plumbing and drainage — Water services	N/A	N/A	N/A	B5D6
No.	Date	Title	Volume One	Volume Two	Housing Provisions	Volume Three
AS/NZS 3500 Part 1	2021	Plumbing and drainage — Water services	N/A	N/A	N/A	B1D3, B1D5, B1D6, B3D3, B5V1, B5D2, B5D3, B5D4, Spec 41, B6D2, B6D3, B6D5, B7D3,
AS/NZS 3500 Part 2	2021	Plumbing and drainage — Sanitary plumbing and drainage (incorporating amendment 1)	N/A	N/A	N/A	C1D3, C1V1, C1V2, C1V3, C1V4, C1V5, C2V2, C2D3, C2D4, C3D7
AS/NZS 3500 Part 3	2021	Plumbing and drainage — Stormwater drainage (See Note 11)	F1D3	H2D2, H2D6	7.4.3	N/A
AS/NZS 3500 Part 4	2021	Plumbing and drainage — Heated water services (incorporating amendment 1)	N/A	N/A	N/A	B2D2, B2D6, B2D7, B2D8, B2D9, B2D11
AS 3600	2018	Concrete structures (incorporating amendments 1 and 2)	B1V1, B1D4, Spec 1	H1V1, H1D4, Spec 1	3.4.2, 4.2.6, 4.2.10, 4.2.13, 5.3.3, 10.2.9	Spec 1
AS 3660 Part 1	2014	Termite management — New building work (incorporating amendment 1)	B1D4, F1D6	N/A	3.4.1, 3.4.2	N/A
AS 3660 Part 3	2014	Termite management — Assessment criteria for termite management systems	N/A	N/A	3.4.2	N/A
AS/NZS 3666 Part 1	2011	Air-handling and water systems of buildings — Microbial control — Design, installation and commissioning	F4D10, F6D6	N/A	N/A	N/A
AS 3700	2018	Masonry structures	B1D4, F3D5, Spec 1, Spec 2	H1D5, H2D4, Spec 1, Spec 2	5.3.3, 5.4.2, 5.6.3, 6.3.6, 10.2.9, 10.2.19, 10.2.20, 12.4.3	Spec 1, Spec 2
AS 3740	2021	Waterproofing of domestic wet areas	F2D2	H4D2, H4D3	10.2.20	N/A
AS 3786	2014	Smoke alarms using scattered light, transmitted light or ionization (incorporating amendment 1 and 2) (See Note 5)	Spec 20	N/A	9.5.1	N/A
AS/NZS 3823 Part 1.2	2012	Performance of electrical appliances — Air conditioners and heat pumps — Ducted air conditioners and air-to-air heat pumps — Testing and rating for performance	Spec 33, J6D12	N/A	N/A	N/A



No.	Date	Title	Volume One	Volume Two	Housing Provisions	Volume Three
AS 3959	2018	Construction of buildings in bushfire-prone areas (incorporating amendments 1 and 2)	C2D14, F8D5, G5D2, G5D3, Spec 43	H7D4	10.8.3	B1D4, B2D10, B3D4, C1D4, C2D5
AS/NZS 4020	2018	Testing of products for use in contact with drinking water (See Note 6)	A5G4	A5G4	N/A	A5G4
AS 4055	2021	Wind loads for housing	Schedule 1	H1D6, H1D8, Schedule 1	2.2.3, Schedule 1	Schedule 1
AS 4072 Part 1	2005	Components for the protection of openings in fire-resistant separating elements — Service penetrations and control joints (incorporating amendment 1)	C4D15, C4D16	N/A	9.3.2	N/A
AS 4100	2020	Steel structures	B1D4, Spec 1	H1D6, Spec 1	4.2.13, 5.6.7	Spec 1
AS 4200 Part 1	2017	Pliable building membranes and underlays — Materials (incorporating amendment 1)	F3D3, F8D3, Spec 36, Schedule 1	Schedule 1	7.3.4, 7.5.2, 7.5.8, 10.8.1, Schedule 1	Schedule 1
AS 4200 Part 2	2017	Pliable building membranes and underlays — Installation requirements (incorporating amendments 1 and 2)	F3D3, F8D3	N/A	10.8.1	N/A
AS/NZS 4234	2021	Heated water systems — Calculation of energy consumption	Spec 45	N/A	N/A	B2D2
AS 4254 Part 1	2021	Ductwork for air-handling systems in buildings — Flexible duct	Spec 7, J6D7	H3D2	13.7.4	N/A
AS 4254 Part 2	2012	Ductwork for air-handling systems in buildings — Rigid duct	Spec 7, J6D5, J6D7	N/A	13.7.4	N/A
AS/NZS 4284	2008	Testing of building facades	F3V1	H2V1	N/A	N/A
AS/NZS 4505	2012	Garage doors and other large access doors (incorporating amendment 1)	B1D4	N/A	2.2.4	N/A
AS 4552	2005	Gas fired water heaters for hot water supply and/or central heating	N/A	N/A	N/A	B2D2
AS 4586	2013	Slip resistance classification of new pedestrian surface materials (incorporating amendment 1) (See Note 7)	D3D11, D3D14, D3D15. Spec 27	N/A	11.2.4	N/A
AS 4597	1999	Installation of roof slates and shingles (Non-interlocking type)	B1D4, F3D2	H1D7	N/A	N/A
AS/NZS 4600	2018	Cold-formed steel structures	B1D4, Spec 1	H1D6, Spec 1	5.3.3, 6.3.6	Spec 1
No.	Date	Title	Volume One	Volume Two	Housing Provisions	Volume Three
AS 4654 Part 1	2012	Waterproofing membranes for external above-ground use — Materials	F1D5	H2D8	N/A	N/A
AS 4654 Part 2	2012	Waterproofing membranes for external above-ground use — Design and installation	C2D14, F1D4, F1D5	H2D8	N/A	N/A
AS 4678	2002	Earth-retaining structures	N/A	H1D3	N/A	N/A
AS 4773 Part 1	2015	Masonry in small buildings — Design (incorporating amendment 1)	N/A	H1D5, H2D4	5.6.3, 12.4.3	N/A
AS 4773 Part 2	2015	Masonry in small buildings — Construction (incorporating amendment 1)	N/A	H1D5, H2D4	5.6.3, 12.4.3	N/A
AS/NZS 4859 Part 1	2018	Thermal insulation materials for buildings — General criteria and technical provisions	J4D3, J6D6, J6D9	N/A	13.2.2, 13.7.2, 13.7.4	N/A
AS/NZS 4859 Part 2	2018	Thermal insulation materials for buildings — Design	J3D8, J4D3, Spec 36, Spec 37	N/A	13.2.5, 13.2.6	N/A
AS/NZS 4858	2004	Wet area membranes	N/A	N/A	10.2.8	N/A
AS 5113	2016	Classification of external walls of buildings based on reaction-to-fire performance (incorporating amendment 1)	C1V3	N/A	N/A	N/A
AS 5146 Part 1	2015	Reinforced autoclaved aerated concrete — Structures (incorporating amendment 1)	B1D4	H1D7	N/A	N/A
AS 5146 Part 3	2018	Reinforced autoclaved aerated concrete — Construction	F3D5	N/A	N/A	N/A
AS 5216	2021	Design of post-installed and cast-in fastenings in concrete	B1D4	N/A	2.2.4	N/A
AS/NZS 5601 Part 1	2013	Gas installations — General installations	J1V4	H6V3	N/A	N/A
AS 5637 Part 1	2015	Determination of fire hazard properties — Wall and ceiling linings	Spec 7, Schedule 1	Schedule 1	Schedule 1	Schedule 1
AS ISO 9239 Part 1	2003	Reaction to fire tests for floorings — Determination of the burning behaviour using a radiant heat source	Schedule 1	Schedule 1	Schedule 1	Schedule 1
AS/NZS ISO 9972	2015	Thermal performance of buildings — Determination of air permeability of buildings — Fan pressurization method	J1V4	H6V3	N/A	N/A
AIRAH-DA07	2021	Criteria for moisture control design analysis in buildings	F8V1	H4V5	N/A	N/A



No.	Date	Title	Volume One	Volume Two	Housing Provisions	Volume Three
AIRAH-DA09	1998	Air conditioning load estimation	Spec 35	N/A	N/A	N/A
AIRAH-DA28	2011	Building management and control systems	Spec 34	N/A	N/A	N/A
ANSI/ASHRAE Standard 55	2013	Thermal environmental conditions for human occupancy	Schedule 1	Schedule 1	Schedule 1	Schedule 1
ANSI/ASHRAE Standard 140	2007	Standard method of test for the evaluation of building energy analysis computer programs	J1V1, J1V2, J1V3, J1V5	H6V2	N/A	N/A
ASTM E2073-10	2010	Standard Test Method for Photopic Luminance of Photoluminescent (Phosphorescent) Markings	Spec 25	N/A	N/A	N/A
ASTM E72-15	2015	Standard Test Methods of Conducting Strength Tests of Panels for Building Construction	Spec 6	N/A	N/A	N/A
ASTM E695-03	2003	Standard Test Method of Measuring Relative Resistance of Wall, Floor and Roof Construction to Impact Loading	Spec 6	N/A	N/A	N/A
ASTM E96	2016	Standard Test Methods for Water Vapor Transmission of Materials	Schedule 1	Schedule 1	Schedule 1	Schedule 1
AHRI 460	2005	Performance rating of remote mechanical-draft air-cooled refrigerant condensers	J6D13	N/A	N/A	N/A
AHRI 551/591	2015	Performance rating of water-chilling and heat pump water-heating packages using the vapor compression cycle.	Spec 33, J6D11	N/A	N/A	N/A
ABCB	2022	Fire Safety Verification Method	C1V4	N/A	N/A	N/A
ABCB	2022	Housing Provisions Standard	N/A	Throughout	Throughout	N/A
ABCB	2022	Livable Housing Design	G7D2	H4D3, H8D2	3.3.3, 11.2.3	N/A
ABCB	2011	Protocol for Structural Software, Version 2011.2	B1D5	H1D6	2.2.5	N/A
ABCB	2012	Standard for Construction of Buildings in Flood Hazard Areas, Version 2012.3	B1D6	H1D10	N/A	N/A
ABCB	2022	Standard for NatHERS Heating and Cooling Load Limits, Version 2022.1	J3D3	Spec 42	N/A	N/A
ABCB	2022	Standard for Whole-of-Home Efficiency Factors	J3D14	N/A	13.6.2	N/A
CIBSE Guide A	2015	Environmental design	Spec 34, Spec 35, J4D3, J4D7	N/A	N/A	N/A
No.	Date	Title	Volume One	Volume Two	Housing Provisions	Volume Three
N/A	2002	Disability Standards for Accessible Public Transport	F4D12, I2D1	N/A	N/A	N/A
N/A	2010	Education and Care Services National Law Act (Vic)	Schedule 1	Schedule 1	Schedule 1	Schedule 1
European Union Commission Regulation 547/2012	2012	Eco-design requirements for water pumps	J6D8	N/A	N/A	N/A
European Union Commission Regulation 622/Annex II, point 2	2012	Eco-design requirements for glandless standalone circulators and glandless circulators integrated in products	J6D8	N/A	N/A	N/A
FPA101D	2021	Automatic Fire Sprinkler System Design and Installation — Drinking Water Supply	C1V3, C2D6, C2D13, C3D2, C3D7, C3D8, C4D6, C4D7, C4D8, C4D9, C4D12, Spec 5, Spec 7, D2D4, D2D17, D3D26, D3D30, E2D8, E2D9, E2D13, E2D14, E2D15, E2D16, E2D17, E2D19, E2D20, Spec 17, Spec 18, Spec 20, G3D1, G3D6, Spec 31, I1D2, Schedule 1	Schedule 1	Schedule 1	B4D3, Schedule 1



No.	Date	Title	Volume One	Volume Two	Housing Provisions	Volume Three
FPA101H	2018	Automatic Fire Sprinkler System Design and Installation — Hydrant Water Supply (incorporating amendment 1)	C1V3, C2D6, C2D13, C3D2, C3D7, C3D8, Spec 5, Spec 7, Spec 17, Spec 18, E2D8, E2D9, E2D13, E2D14, E2D15, E2D16, E2D17, E2D19, E2D20, Spec 20, G3D1, G3D6, Spec 31, I1D2	N/A	N/A	B4D3
ISO 140 Part 6	1998E	Acoustics — Measurement of sound insulation in buildings and of building elements — Laboratory measurements of impact sound insulation of floors	Spec 29	N/A	N/A	N/A
ISO 540	2008	Hard coal and coke — Determination of ash fusibility	Spec 13	N/A	N/A	N/A
ISO 8336	1993E	Fibre-cement flat sheets	Schedule 1	Schedule 1	7.5.3, 7.5.4, 7.5.5, Schedule 1	Schedule 1
ISO 25745 Part 2	2015	Energy performance of lifts, escalators and moving walks: Energy calculation and classification for lifts (elevators)	J7D8	N/A	N/A	N/A
NASH Standard	2021	Steel Framed Construction in Bushfire Areas	N/A	H7D4	N/A	N/A
NASH Standard Part 1	2005	Residential and Low Rise Steel Framing — Design Criteria (incorporating amendments A, B and C)	B1D4	H1D6	N/A	N/A
NASH Standard Part 2	2014	Residential and Low Rise Steel Framing — Design Solutions (incorporating amendment A)	B1D4, B1D5, F1D8	H1D6	2.2.5, 6.2.1, 6.3.6, 7.5.2, 7.5.3, 7.5.4, 10.2.19, 10.2.20	N/A
NSF/ANSI/ CAN 372	2020	Drinking Water System Components - Lead Content	A5G4	A5G4	N/A	A5G4
N/A	N/A	Northern Territory Deemed to Comply Standards Manual	N/A	N/A	2.2.4	N/A
SATS 5344	2019	Permanent labelling for Aluminium Composite Panel (ACP) products	A5G8	A5G8	N/A	A5G8
TN 61	N/A	Cement Concrete and Aggregates Australia — Technical note — Articulated walling	N/A	H1D4	N/A	N/A

Table Notes

- (1) For AS/NZS ISO 717.1:
 - (a) Test reports based on AS 1276—1979 and issued prior to AS/NZS 1276.1—1999 being referenced in the NCC remain valid.
 - (b) The STC values in reports based on AS 1276—1979 must be considered to be equivalent to Rw values.
 - (c) Test reports based on AS/NZS 1276.1 prepared after the NCC reference date for AS/NZS 1276.1—1999 must be based on that version.
 - (d) Test reports based on ISO 717-1—1996 and issued prior to AS/NZS ISO 717.1—2004 being referenced in the NCC remain valid.
 - (e) Reports based on AS/NZS ISO 717.1 relating to tests carried out after the NCC reference date for AS/NZS ISO 717.1—2004 must relate to the amended Standard.
- (2) For AS 1562.1, tests carried out based on AS 1562.1—1992 and issued prior to AS 1562.1—2018 being referenced in the NCC remain valid. Reports relating to tests carried out after the NCC reference date for AS 1562.1 must relate to the revised Standard.
- (3) For AS 1670.1, AS 1670.3 and AS 1670.4, notwithstanding A4G1(5), until the adoption of NCC 2025 the editions of the documents listed in Table 1.8 of AS 1670.1, AS 1670.3 and AS 1670.4 may be used to meet the requirements of AS 1670.1, AS 1670.3 and AS 1670.4 as applicable.
- (4) For AS 2047:
 - (a) Tests carried out under earlier editions of AS 2047 remain valid.
 - (b) Reports based on AS 2047 relating to tests carried out after the NCC reference date for AS 2047—2014 Amendment 2 must relate to the amended Standard.
- (5) For AS 3786:
 - (a) Tests carried out under AS 3786—2014 Amendment 1 remain valid.
 - (b) Reports based on AS 3786 relating to tests carried out after the NCC reference date for AS 3786—2014 Amendment 2 must relate to the amended Standard.
- (6) Test reports based on the 2005 edition of AS/NZS 4020 will continue to be accepted until 1 May 2024. Test reports prepared after the NCC reference date for the 2018 edition of AS/NZS 4020 must be based on the 2018 edition.
- (7) For AS 4586:
 - (a) Test reports based on the 2004 edition of AS/NZS 4586 and issued prior to the 2013 edition of AS 4586 being referenced in the NCC remain valid.
 - (b) Test reports prepared after the NCC reference date of the 2013 edition of AS 4586 must be based on that version.
 - (c) For the purposes of assessing compliance, the slip-resistance classifications of V, W and X in reports based on the 2004 edition of AS/NZS 4586 may be considered to be equivalent to slip-resistance classifications of P5, P4 and P3 respectively in the 2013 edition of AS 4586.
 - (d) Test reports based on Appendix D of AS 4586—2013 and issued prior to the NCC reference date for AS 4586—2013 (incorporating Amendment 1) remain valid.
 - (e) Test reports based on Appendix D of AS 4586—2013 and prepared after the NCC reference date for AS 4586—2013 (incorporating Amendment 1) must be based on that version.
- (8) Tests carried out based on AS/NZS 2918—2001 and issued prior to AS/NZS 2918—2018 being referenced in the NCC remain valid. Reports relating to tests carried out after the NCC reference date for AS/NZS 2918 must relate to the revised Standard.
- (9) For AS 2699 Parts 1 and 3:
 - (a) For AS 2699.1, the 2000 edition has been retained for a transitional period ending on 30 April 2025.
 - (b) For AS 2699.3, the 2002 edition has been retained for a transitional period ending on 30 April 2025.
- (10) For AS 1397, the 2011 edition has been retained for a transitional period ending on 31 August 2023.
- (11) For AS/NZS 3500.3, the 2018 edition has been retained for a transitional period ending on 31 August 2023.



NSW Table 1 SCHEDULE OF REFERENCED DOCUMENTS

No.	Date	Title	Volume One	Volume Two	Housing Provisions
AS/NZS 1596	2014	The Storage and Handling of LP Gas	NSW I4D61	N/A	N/A
AS 1603	2018	Automatic fire detection and alarm systems — Heat alarms (See Note 1)	N/A	N/A	NSW 9.5.1
AS 2001 Part 5.4	2005	Methods of test for textiles: Dimensional washing and drying procedures for textile texting		N/A	N/A
AS/NZS 3000	2018	Electrical installations (known as the Australian/New Zealand Wiring Rules)	NSW I5D14	N/A	N/A
AS/NZS 3002	2008	Electrical installations — Shows and carnivals	NSW I5D14	N/A	N/A
SSL	N/A	Appraisal Specification FAS 102	NSW I4D46	N/A	N/A
NSW Legislation	1979	Environmental Planning and Assessment Act	NSW G5D3, NSW Schedule 1	NSW H7D4, NSW Schedule 1	N/A
NSW Legislation	2021	Environment Planning and Assessment Regulation	NSW I4D1, NSW I4D46, NSW Schedule 1	NSW Schedule 1	NSW Schedule 1
NSW Legislation	2007	Liquor Act	NSW Schedule 1	NSW Schedule 1	NSW Schedule 1
NSW Legislation	1997	Rural Fires Act	NSW G5D3, NSW G5D4, NSW Schedule 1	NSW Schedule 1	NSW Schedule 1
NSW Legislation	N/A	Standard Instrument— Principal Local Environmental Plan	NSW Schedule 1	NSW Schedule 1	NSW Schedule 1
NSW Legislation	1992	Swimming Pools Act	NSW G1P2, NSW G1D2, NSW Schedule 1	NSW H7P1, NSW H7D2, NSW Schedule 1	NSW Schedule 1
NSW Legislation	2018	Swimming Pools Regulation	NSW G1P2, NSW G1D2	NSW H7P1, NSW H7D2	N/A
NSW Legislation	2011	Work Health and Safety Act	NSW G1D5	N/A	N/A

Table Notes

(1) Heat alarms complying with AS 1603.3 must be a class type A1 or A2.

APPENDIX C – REFERENCED DOCUMENTATION

The following documentation was used in the preparation of this report:

Drawing No.	Title	Rev.	Project No.	Date	Drawn By
A-110-010	Basement 02	05	2509	10.02.2026	Studio Johnston
A-110-020	Basement 01	05	2509	10.02.2026	Studio Johnston
A-110-030	Lower Ground 02	05	2509	10.02.2026	Studio Johnston
A-110-040	Lower Ground 01	05	2509	10.02.2026	Studio Johnston
A-110-050	Ground Level	05	2509	10.02.2026	Studio Johnston
A-110-060	Level 1	05	2509	10.02.2026	Studio Johnston
A-110-070	Level 2	05	2509	10.02.2026	Studio Johnston
A-110-080	Level 3	05	2509	10.02.2026	Studio Johnston
A-110-090	Level 4	05	2509	10.02.2026	Studio Johnston
A-110-100	Level 5	05	2509	10.02.2026	Studio Johnston
A-110-110	Level 6	05	2509	10.02.2026	Studio Johnston
A-110-120	Level 7	05	2509	10.02.2026	Studio Johnston
A-110-130	Roof	05	2509	10.02.2026	Studio Johnston
A-210-010	North Elevation	05	2509	10.02.2026	Studio Johnston
A-210-020	South Elevation	05	2509	10.02.2026	Studio Johnston
A-210-030	East Elevation	05	2509	10.02.2026	Studio Johnston
A-210-040	West Elevation	05	2509	10.02.2026	Studio Johnston
A-310-010	Section AA	05	2509	10.02.2026	Studio Johnston
A-310-020	Section BB	05	2509	10.02.2026	Studio Johnston