



Travers

bushfire & ecology

Vegetation Management Plan

Lot 1, DP1151370
1 Sirius Road
Lane Cove West

AWE Doc No Added 110319
ATSYD2-SSD-REP-LAN-VMP01

December 2018
(REF: 18AWE02V)



Vegetation Management Plan

Lot 1, DP1151370
1 Sirius Road
Lane Cove West

| | |
|-----------------|--|
| Report Authors: | George Plunkett B. Sc. (Hons.), PhD – Botanist Michael Sheather-Reid B. Nat. Res. (Hons.) – Managing Director |
| Plans prepared: | Sandy Cardow B. Sc. Alexandra Scott B. Sc. |
| Approved by: | Michael Sheather-Reid B. Nat. Res. (Hons.) – Managing Director |
| Date: | 18 December 2018 |
| File: | 18AWE02V |

This document is copyright ©

Disclaimer:

This report has been prepared to provide advice to the client on matters pertaining to the particular and specific development proposal as advised by the client and / or their authorised representatives. This report can be used by the client only for its intended purpose and for that purpose only. Should any other use of the advice be made by any person, including the client, then this firm advises that the advice should not be relied upon. The report and its attachments should be read as a whole and no individual part of the report or its attachments should be interpreted without reference to the entire report.

The mapping is indicative of available space and location of features which may prove critical in assessing the viability of the proposed works. Mapping has been produced on a map base with an inherent level of inaccuracy, the location of all mapped features are to be confirmed by a registered surveyor.

TBE Environmental Pty Ltd
ABN 85 624 419 870
PO Box 7138
Kariang NSW 2250

38A The Avenue
Mt Penang Parklands
Central Coast Highway
Kariang NSW 2250

t: 02 4340 5331
e: info@traverseecology.com.au
www.traverseecology.com.au

Table of Contents

| | |
|---|-----------|
| SECTION 1.0 – INTRODUCTION | 1 |
| 1.1 Proposed development..... | 1 |
| 1.2 Aims of the vegetation management plan | 3 |
| SECTION 2.0 – MANAGEMENT CONTEXT | 4 |
| 2.1 Site description | 4 |
| 2.2 Vegetation descriptions | 4 |
| 2.3 Vegetation condition and connectivity | 8 |
| 2.4 Riparian features | 8 |
| 2.5 Contaminated land | 9 |
| SECTION 3.0 – RESTORATION STRATEGY | 11 |
| 3.1 Site preparation | 11 |
| 3.1.1 Temporary protection fencing | 11 |
| 3.1.2 Permanent protection fencing | 11 |
| 3.1.3 Signage | 11 |
| 3.1.4 Hollow-bearing trees | 12 |
| 3.1.5 Contaminated lands remediation..... | 12 |
| 3.2 Weed management | 12 |
| 3.2.1 Weed management strategy | 13 |
| 3.3 Restoration works..... | 15 |
| 3.3.1 Overview restoration and revegetation..... | 15 |
| 3.3.2 Bushland regeneration area..... | 16 |
| 3.3.3 Revegetation area: Fully-structured Smooth-barked Apple - Red Bloodwood open forest..... | 16 |
| 3.3.4 Revegetation area: contaminated lands | 16 |
| 3.3.5 Mulching | 17 |
| 3.3.6 Revegetation protection | 18 |
| 3.4 Sediment and erosion control | 19 |
| 3.5 Hollow-bearing trees and nest box installation | 20 |
| 3.5.1 Retention of hollow-bearing trees..... | 22 |
| SECTION 4.0 – MANAGEMENT AND MONITORING | 24 |
| 4.1 Management of restoration works..... | 24 |
| 4.2 Monitoring..... | 24 |
| 4.3 Compliance certification..... | 25 |
| 4.4 Funding | 25 |
| 4.5 Restoration performance targets | 26 |
| SECTION 5.0 – PROGRAM OF WORKS | 27 |
| 5.1 Program of works | 27 |
| 5.2 Typical timeline of restoration works | 29 |

Figures

| | |
|---|----|
| Figure 1 – Study area | 1 |
| Figure 2 – Site master plan | 2 |
| Figure 3 – Riparian land mapping (Lane Cove LEP mapping 2009) | 9 |
| Figure 4 – Contaminated area in the north-east of the lot | 10 |
| Figure 5 – Signage example | 12 |
| Figure 6 – Example of open weave jute mesh | 18 |
| Figure 7 – Generic riparian bank stabilisation | 18 |
| Figure 8 – Generic installation detail of geotextile filter fence | 19 |
| Figure 9 – Outlet scour protection | 20 |
| Figure 10 – Typical restoration timeline (3 years maintenance) | 30 |

Tables

| | |
|---|----|
| Table 1 – Site features | 4 |
| Table 2 – Summary of hollow-bearing trees | 22 |
| Table 3 – Program of works | 28 |
| Table A1 – Recommended planting list for restoration zone | 31 |
| Table A2 – Target weed species for the site | 33 |

Attachments

| | |
|--------------|---------------------------|
| Attachment 1 | Recommended Planting List |
| Attachment 2 | Target Weed Species |
| Attachment 3 | Nest Box Specifications |

Schedules

| | |
|------------|-----------------------------|
| Schedule 1 | Vegetation Management Works |
|------------|-----------------------------|

List of abbreviations

| | |
|----------|---|
| APZ | asset protection zone |
| BPA | bushfire protection assessment |
| BC Act | <i>Biodiversity Conservation Act 2016</i> |
| DCP | Development Control Plan |
| DEC | NSW Department of Environment and Conservation |
| DECC | NSW Department of Environment and Climate Change |
| DECCW | NSW Department of Environment, Climate Change and Water |
| DoEE | Federal Department of Environment and Energy(formerly SEWPAC) |
| EEC | endangered ecological community |
| EPA | Environmental Protection Agency |
| EP&A Act | <i>Environmental Planning and Assessment Act 1979</i> |
| EPBC Act | <i>Environment Protection and Biodiversity Conservation Act 1999</i> |
| FF | flora and fauna assessment |
| FM Act | <i>Fisheries Management Act 1994</i> |
| FMP | fuel management plan |
| IPA | inner protection area |
| LEP | Local Environment Plan |
| LGA | local government area |
| NES | national environmental significance |
| NPWS | NSW National Parks and Wildlife Service |
| NSW DPI | NSW Department of Industry and Investment |
| OEH | Office of Environment and Heritage (Part of the NSW Department of Premier and |
| OPA | outer protection area |
| PBP | <i>Planning for Bush Fire Protection 2006: A Guide for Councils, Planners, Fire Authorities</i> |
| POEO | <i>Protection of the Environmental Operations Act 1997</i> |
| POM | plan of management |
| RF Act | <i>Rural Fires Act</i> |
| RFS | NSW Rural Fire Service |
| SIS | species impact statement |
| SOFF | Swamp Oak Floodplain Forest |
| VMP | vegetation management plan |



Introduction

1

Travers bushfire & ecology has been engaged to prepare a vegetation management plan (VMP) for the lands located within Lot 1, DP1151370, 1 Sirius Road, Lane Cove West in the Lane Cove local government area (LGA).

Existing vegetation within the lot is composed of remnant native forest and exotic vegetation. This VMP has been prepared to enable the restoration of retained native vegetation within the site and to identify additional revegetation works appropriate to the site.

1.1 Proposed development

The proposal is for a Data Centre for cloud computing services. The proposed development would service development of the Metropolitan Sydney Region, ultimately providing an advanced facility to support the growth and development of IT infrastructure.

The proposed facility is a commercial venture and will be operated 24/7. The proposed development is shown in Figure 2.



Figure 1 – Study area
(Source: SIX Maps)

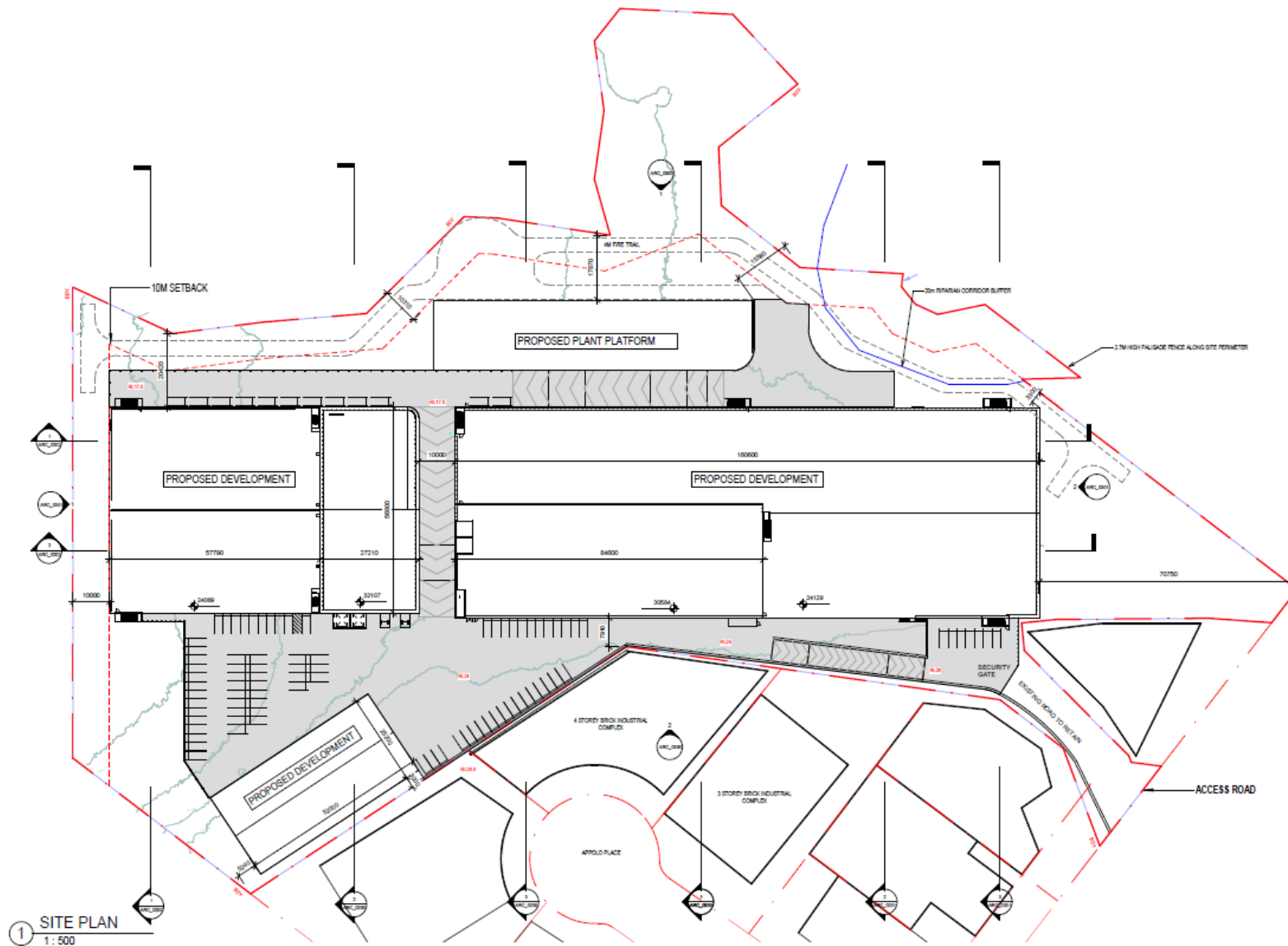

Figure 2 – Ground floor plan
 (Source: Greenbox Architecture Pty Ltd)

1.2 Aims of the vegetation management plan

The following objectives for the VMP include:

- To protect, restore and maintain retained native vegetation.
- To revegetate selected areas with appropriate native vegetation of local provenance.
- Maximise native vegetation cover and species diversity within the restoration areas.
- Minimise weed cover to ensure long term establishment of native vegetation
- Undertake monitoring, auditing and maintenance activities to ensure an effective and a resilient restoration outcome
- Ensure compliance with the development consent and this VMP.

Schedule 1 of this VMP provides a layout of VMP works and the performance targets to be achieved by contractors undertaking restoration works. The VMP provides guidelines for how the restoration works are to be undertaken and is subject to compliance certification.



Management Context

2

The following sections provide a brief description of the site.

2.1 Site description

Table 1 provides a summary of the planning, cadastral, topographical, and disturbance details of the subject site.

Table 1 – Site features

| | |
|-------------------------------|--|
| Location | Lot 1, DP1151370, 1 Sirius Road, Lane Cove West |
| Size | Approximately 3.957 ha |
| Grid reference | 328287E 6257617N |
| Elevation | Approximately 2–25m AHD |
| Topography | Situated in a moderate to very steep slope with a north-western aspect. |
| Geology and soils | <p>Geology: Hawkesbury Sandstone – Medium to coarse grained quartz sandstone, very minor shale and laminate lenses.</p> <p>Soils: Gymea – shallow to moderately deep (30-100 cm) Yellow Earths (Gn2.24) and Earthy Sands (Uc5.11,Uc5.23) on crests and inside of benches; shallow (<20 cm) Siliceous Sands (Uc1.21) on leading edges of benches; localised Gleyed Podzolic Soils (Dg4.21) and Yellow Podzolic Soils (Dy4.11, Dy5.11, Dy5.41) on shale lenses; shallow to moderately deep (<100 cm) Siliceous Sands (Uc1.21) and Leached Sands (Uc2.21) along drainage lines.</p> |
| Catchment drainage and | Hawkesbury catchment. Overland flow into Stringybark Creek in the north and Lane Cove River in the west. No streams or waterbodies occur the study area. |
| Vegetation | Remnant forest and exotic vegetation. |
| Existing land use | Vacant. Zoned IN2 - light industrial. |
| Clearing | >80% of the original vegetation has been cleared. |

2.2 Vegetation descriptions

Vegetation communities observed within the study site include:

- Smooth-barked Apple - Red Bloodwood open forest on enriched sandstone slopes around Sydney and the Central Coast (PCT 1776)
- Disturbed land / exotics

Smooth-barked Apple - Red Bloodwood open forest on enriched sandstone slopes around Sydney and the Central Coast (PCT 1776)

This vegetation community is located in the north eastern and south western corners of the study site.

Canopy – Dominated by *Angophora costata*, *Eucalyptus piperita* and *Eucalyptus resinifera* with occasional *Corymbia gummifera* and *Eucalyptus pilularis* to a height of 30m and with a projected foliage cover (PFC) of 35–45%.

Midstorey – *Acacia parramattensis*, *Acacia suaveolens*, *Allocasuarina littoralis*, *Dodonaea triquetra*, *Grevillea buxifolia*, *Micrantheum ericoides*, *Notelaea longifolia*, *Woolfsia pungens*, *Zieria pilosa*, *Elaeocarpus reticulatus* and *Glochidion ferdinandi* with a PFC of 5–25%.

Groundlayer – The groundlayer contained a high cover and species richness of native grasses, forbs and sedges including *Austrostipa pubescens*, *Entolasia stricta*, *Gonocarpus teucroides*, *Imperata cylindrica*, *Lepidosperma laterale*, *Lomandra longifolia* and *Lomandra multiflora* subsp. *multiflora* with a PFC of up to 40%. Portions of the vegetation community have been underscrubbed, resulting in the thinning, and in some instances the complete removal, of the midstorey.

The condition of this vegetation community is variable with some areas in a relatively undisturbed condition with low levels of exotic species, particularly woody weeds, while other areas have been disturbed, resulting in a high cover of woody weeds, such as *Cinnamomum camphora*, *Ligustrum lucidum*, *Ligustrum sinense*, *Robinia pseudoacacia* and *Ochna serrulata*.



Photo 1 – Smooth-barked Apple - Red Bloodwood open forest (PCT 1776) in the north-eastern corner of the site.



Photo 2 – Smooth-barked Apple - Red Bloodwood open forest (PCT 1776) in the southern corner of the site.



Photo 3 – Smooth-barked Apple - Red Bloodwood open forest (PCT 1776) with shrub layer dominated by exotic shrubs *Ligustrum sinense* and *Lantana camara*.

Disturbed land / exotics

This vegetation community covers the majority of the entire site and is dominated by exotic trees, shrubs and groundcovers including *Ligustrum sinense*, *Ligustrum lucidum*, *Cinnamomum camphora*, *Robinia pseudoacacia*, *Lantana camara*, *Rubus fruticosus* spp. agg., *Ageratina adenophora*, *Asparagus aethiopicus*, *Cenchrus clandestinus*, *Cirsium vulgare*, *Ochna serrulata*, *Ehrharta erecta* and *Eragrostis curvula*.



Photo 4 – Disturbed land / exotics in the south-west of the site looking south-west.



Photo 5 – Disturbed land / exotics in the centre of the site looking east.



Photo 6 – Disturbed land / exotics in the centre of the site looking north.

2.3 Vegetation condition and connectivity

There are two (2) main patches of native vegetation within, and extending off, the site in the north-east and south of the lot. The north-eastern patch contributes to a connective corridor running east to west parallel to Stringy Bark Creek, which links vegetation further upstream with riparian vegetation along the eastern bank of Lane Cove River. The condition of this vegetation is variable, with some areas in a relatively undisturbed condition, while other areas have been disturbed, resulting in a high cover of woody weeds. The remainder of the site is in poor to very poor condition with vegetation comprised of exotic species.

Ultimately, the proposal will reduce the width of the corridor but will not break any local vegetative connectivity attributes, nor isolate any remnant patches of vegetation worthy of conservation for local flora or fauna.

2.4 Riparian features

Stringybark Creek (2nd order stream) occurs just to the north of the lot and outside the restoration areas (see Schedule 1). A 20m riparian buffer from the top of bank extends into the study area (see Schedule 1) and is to be revegetated as specified in this VMP.

Lane Cove River is to the north-western aspect of the site and as a high order stream it attracts a 40m riparian buffer from top of bank. This buffer impacts the north-western portion and the western corner of the lot.

The Lane Cove Local Environment Plan (LEP) mapping (2009) identifies a portion in the north of the site as Riparian Land.

Regarding “riparian land”, Lane Cove LEP states:

development consent must not be granted for development on land to which this clause applies unless the consent authority has considered the impact of the proposed development on the land and any opportunities for rehabilitation of aquatic and riparian vegetation and habitat on that land.



Figure 3 – Riparian land mapping (Lane Cove LEP mapping 2009)



Photo 7 – Edge of Stringybark Creek just outside the northern boundary of the lot.

2.5 Contaminated land

A current contaminated lands notice applies to an area the north-east of the lot (formerly Lot 2 DP 884454 and Lot 1 DP 546860 before that). This notice states that:

- (a) *The recipient must obtain the prior written approval of the EPA to any works that are to be carried out on the land, whether or not the works are carried out by the recipient, for the purposes of:*
 - (i) *Covering, dispersing or reducing the contamination of the land; or*

- (ii) Restoring or rehabilitating the land; or
 - (iii) Removing or disposing of any soil, sand, rock, water, or any other solid or liquid material of any kind from the land; and
- (b) The recipient must maintain the land in a manner that maintains the integrity and impermeability of the clay capping which is on the land, including selection of vegetation with root systems that do not grow into the clay capping layer; and
- (c) The recipient must not undertake any work, or cause, permit or allow the undertaking of any work which would result in any disturbance to, or modification of the clay capping layer unless the prior written approval of the undertaking has been obtained from the EPA and the work is undertaken in accordance with any conditions of that approval.

A remediation action plan is to be prepared by *Sinversa* that sets out strategies to contain and manage the contaminated soil within the contaminated lands. These remediation works are to be completed before the implementation of any restoration works specified in this VMP within the contaminated lands.

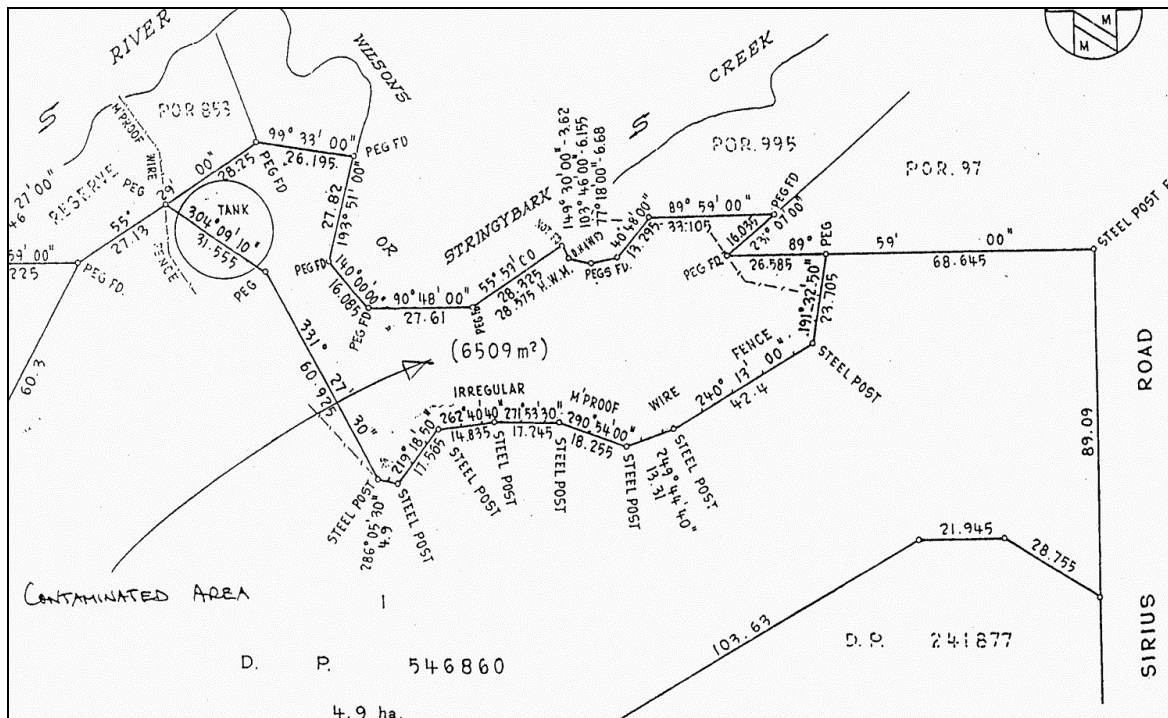

Figure 4 – Contaminated area in the north-east of the lot



Restoration Strategy

3

3.1 Site preparation

Initial site preparation includes the placement of fencing to restrict access, delineate riparian areas and to minimise damage to retained items.

3.1.1 *Temporary protection fencing*

Temporary protection fencing in the form of a 1.8m high relocatable construction proof fence will be provided around the restoration areas as shown on Schedule 1 – Vegetation Management Works. This fencing shall remain in place until all construction and surrounding road works are completed. Construction personnel are to be inducted and notified of the sensitivity of the restoration areas which is to be treated as a 'No Go Zone'.

Sediment fencing is to be installed at the base of the temporary protection fencing as a primary sediment collection measure. It is to be installed and maintained to prevent erosion along the fence and is to include sediment fence kickbacks on sloped lands to slow water directed along the fence. The sediment fence is to be reinforced at all low points with additional hay bales to support the fence against the weight of trapped sediment.

3.1.2 *Permanent protection fencing*

Following completion of earthworks, and installation of stormwater outlets and riparian structures, permanent protection fencing in the form of a 1.2m high chainlink fence is to be installed around the restoration areas as shown on Schedule 1 – Vegetation Management Works. This is to replace the temporary protection fencing.

3.1.3 *Signage*

Signage is to be placed every 50m on the permanent fence around the edge of the restoration areas. This signage is to advise that the area is undergoing bushland rehabilitation works. An example of what may be suitable is provided in Figure 5.



Figure 5 – Signage example

3.1.4 *Hollow-bearing trees*

The proposal will require the removal of ten (10) hollow-bearing trees. Ten (10) compensatory nest boxes are to be installed at least 1 month prior to the commencement of tree removal works to ensure replacement roosting habitat is available.

A total of ten (10) nest boxes are to be installed within the bushland regeneration area in the eastern corner of the lot as shown on Schedule 1 – Vegetation Management Works. These will comprise:

- Five (5) nest boxes suitable for small birds and mammals
- Two (2) nest box suitable for large mammals / possums
- Three (3) microbat boxes

See section 3.5 and Attachment 3 for specifications.

3.1.5 *Contaminated lands remediation*

Remediation works within the contaminated area are to be completed before the implementation of any restoration works within that area. The contaminated area to be revegetated is to be capped with a suitable topsoil to a depth of 1m. Only shrubs and groundcovers with a shallow mature root system are to be planted.

3.2 **Weed management**

Weed control works are to be undertaken within the restoration areas in perpetuity and are to specifically target invasive environmental weeds known to occur. Weed control works are to be monitored and audited by an appointed project ecologist to achieve the landscape management performance targets.

Invasive and persistent weed or environmental pest species have been observed within or in proximity to the site and include:

- *Ageratina adenophora* (Crofton Weed)
- *Arundo donax* (Giant Reed)
- *Asparagus aethiopicus* (Ground Asparagus)
- *Cenchrus clandestinus* (Kikuyu Grass)
- *Cinnamomum camphora* (Camphor Laurel)
- *Cortaderia* sp. (Pampas Grass)
- *Ehrharta erecta* (Panic Veldtgrass)
- *Eragrostis curvula* (African Lovegrass)
- *Festuca* sp.
- *Genista monspessulana* (Montpellier Broom)
- *Lantana camara* (*Lantana*)
- *Ligustrum lucidum* (Large-leaved Privet)
- *Ligustrum sinense* (Small-leaved Privet)
- *Melinis repens* (Red Natal Grass)
- *Nephrolepis cordifolia* (Fishbone Fern)
- *Ochna serrulata* (Mickey Mouse Plant)
- *Olea europaea* subsp. *cuspidata* (African Olive)
- *Paspalum dilatatum* (*Paspalum*)
- *Paspalum urvillei* (Vasey Grass)
- *Passiflora suberosa* (Cork Passionflower)
- *Robinia pseudoacacia* (Black Locust)
- *Rubus fruticosus* (Blackberry)
- *Senna pendula* var. *glabrata*
- *Sporobolus africanus* (Parramatta Grass)
- *Sporobolus fertilis* (Giant Parramatta Grass)
- *Stenotaphrum secundatum* (Buffalo Grass)

These weeds have significant implications to the success of revegetation works and will require intensive targeted weed control and ongoing eradication throughout the planting and maintenance period. Refer to Appendix 2 for more information about which weeds occur on site and the weed control priority.

3.2.1 Weed management strategy

Given the presence of invasive environmental weeds on site, a combination of selective spraying, hand removal and competitive planting techniques will be used to control weeds. The weed control priorities are listed in Attachment 2.

Weeding efforts will also be focussed within the restoration areas as shown in Schedule 1 – Vegetation Management Works. These efforts will provide a buffer against weed incursions from adjoining land uses and provide a sheltered internal habitat for the insitu native flora and fauna. Riparian restoration is to be undertaken in a manner that does not destabilise or further destabilise stream banks. The management aims will be to:

- Manage weeds;
- Increase diversity of native plant species; and
- Increase density of native plant species.

Weeding works are to be carried out by an appropriately qualified and licensed bushland regeneration company under the direction of a consulting project ecologist. Bushland regeneration supervisors should possess a minimum of a Certificate IV in Conservation and Land Management or a biological science degree, with at least three (3) years of field experience and previous experience managing similar vegetation types in northern Sydney.

There are currently a number of low impact bush regeneration techniques used in bushland management for the removal of weeds. The bush regeneration process (Buchanan, 1989) involves:

- The *Bradley Method* of minimal soil disturbance during weed removal
- Clearing and stabilising techniques
- The use of herbicides
- The use of fire (pile burns)
- Biological controls

Employing the *Bradley Method* for regeneration requires the removal of weeds in phases. Stages of weed removal can be broken into three (3) components:

Primary weeding

All weeds will be removed from the native vegetation areas within the site. All weed materials need to be selectively isolated from native vegetation and disposed of separately to native brush, which can be mulched. This involves removal of weeds through targeted herbicide use and hand removal.

Stabilisation of the riparian buffer to reduce erosion and support plantings is to be used in accordance with Figure 7. Mulch to a depth of 75-100mm is to be laid under secured open-weave jute mesh.

Timing – 3–6 months

Secondary or follow-up weeding

Secondary or follow-up weeding involves intensive weeding in areas that have already received primary work to remove weed regrowth or overlooked weeds.

Timing – 6–12 months post commencement of primary weeding

Maintenance weeding

After primary and secondary weeding, and restoration, the area should be able to resist most weeds. However, weeds will re-establish on the site from bird, wind, water transport and other seed or propagule dispersal mechanisms within the site. Maintenance weeding should be undertaken 4–6 times a year until such time as the resistance of the bushland to weeds increases, then only requiring hand weeding on a needs basis. Maintenance weeding is to be conducted for a minimum period of three (3) years. In the event that insufficient weed control is achieved, then contingency works are to be completed for auditing purposes.

The use of herbicides may be needed where hand removal of weeds is impractical. The use of *Glyphosate* based herbicides is recommended in accordance with the manufacturers labels. Within 5m of a drainage line only *Roundup Bi-active*® or equivalent formulations can be used.

Other regularly used herbicides include *Garlon*®, *Brushoff*®, *Brush Killer*® and *Starane 200*®. These non-*Glyphosate* based herbicides are not to be used adjacent to water bodies.

Grazon DS is not considered a safe chemical to use within high soil moisture zones and that significant off target kill of woody species and aquatic fauna has been tentatively linked to *Grazon DS*. It is recommended that this herbicide is not to be used on site.

An advantage of herbicide use is the low time taken to spray weeds as compared to physically removing them, particularly for large infestations of weeds. The disadvantage is that no single herbicide is effective on all weed species, thus the herbicide used needs to achieve an effective kill.

In general, *Travers bushfire & ecology* supports that the use of herbicides in non-ecologically sensitive areas can be undertaken if:

- there are small areas of dense weeds with few or no native plants to protect;
- there are large areas of predominantly weed coverage;
- application can be undertaken without the risk of spray drift or off target kills, and
- weeds are growing too rapidly for physical removal.

The potential for destabilising soils and causing erosion on steep slopes as a result of spraying vegetation with herbicide needs to be considered prior to commencement of weed control works.

Only operators with *Chemcert* or equivalent training must undertake the spraying of weeds. The operator must evaluate the success of each treatment after a set period of time, according to the labelled effective treatment of each species for each herbicide. Care must be taken when applying herbicides near water bodies due to the sensitivity of the waterways and resident flora and fauna to runoff containing these herbicides.

All herbicides must be applied according to the herbicide usage label and provisions of the *Protection of the Environmental Operations Act (NSW POEO Act)*.

All environmental weeds need to be eradicated and controlled across the entire site. Garden waste and weed propagules (seeds, tubers etc.) need to be periodically collected and disposed of at an approved waste transfer facility and shall not be dumped on adjacent bushland or allowed to be washed downstream.

3.3 Restoration works

3.3.1 Overview restoration and revegetation

Restoration works are to be undertaken in areas outside of the APZ. This is to involve weed control, bush regeneration and fully-structured revegetation plantings.

Three (3) separate restoration areas are to be implemented:

- *Regeneration area* – Bush regeneration of Smooth-barked Apple - Red Bloodwood open forest involving weed control and natural recruitment of native plants.
- *Revegetation area: Smooth-barked Apple - Red Bloodwood open forest* – Revegetation of disturbed and cleared areas involving weed control and fully-structured plantings of Smooth-barked Apple - Red Bloodwood open forest species. Revegetation is to achieve fully-structured, healthy and diverse native vegetation.
- *Revegetation area: contaminated lands* – Revegetation of contaminated lands involving weed control and shrub and groundcover plantings of Swamp Oak Floodplain Forest species. Revegetation is to achieve a healthy and diverse native vegetation of small shrubs and groundcovers.

Revegetation and direct seeding will utilise local provenance collected seed, including species found within Smooth-barked Apple - Red Bloodwood open forest. A minimum of 25 species is to be used in each community. The final plant installation list is to be approved by the project ecologist.

Native species from Appendix 1 – Table A1 are to be used for revegetation purposes. Alternatives to this list may be used as approved by the project ecologist. The location of the planted species will be determined by the revegetation contractors under the direction of the project ecologist considering existing vegetation communities, any native regeneration present and suitable topographical and bed conditions.

Stabilisation of the riparian buffer to reduce erosion and support plantings is to be used in accordance with Figure 7. Mulch to a depth of 75-100mm is to be laid under secured open-weave jute mesh.

3.3.2 Bushland regeneration area

Regeneration within this vegetation will primarily involve weed control. Bush regeneration is likely to proceed naturally through recruitment of native plants and enrichment planting will not likely be necessary.

3.3.3 Revegetation area: Fully-structured Smooth-barked Apple - Red Bloodwood open forest

Fully-structured revegetation plantings of Smooth-barked Apple - Red Bloodwood open forest are to be undertaken using a minimum of 25 species. The total area of revegetation is to be at least 0.17ha as marked on Schedule 1. Species to be used in the restoration are listed within Attachment 1 and are to be locally-sourced native stock.

Primary planting (Stage 1) is to achieve the following densities of native plants:

- Canopy trees – 1 per 50m² (total area of 800m² = 16 units)
- Sub-canopy trees – 1 per 30m² (total area of 800m² = 27 units)
- Shrubs – 1 per 5m² (total area of 800m² = 160 units)
- Grasses and groundcovers – 4 per 1m² (total area of 800m² = 3,200 units)
- Vines / climbers – 1 per 20m² (total area of 800m² = 40 units)

Contingency planting (Stage 2) is to be achieved at a rate of 15% of the primary planting:

- Canopy trees – 3 units
- Sub-canopy trees – 4 units
- Shrubs – 24 units
- Grasses and groundcovers – 480 units
- Vines / climbers – 6 units

3.3.4 Revegetation area: contaminated lands

Revegetation within the contaminated lands, including the riparian buffer, is to follow remediation works involving capping with topsoil to a depth of 1m. Revegetation will involve plantings of small shrubs and groundcovers with a mature root system that is shallow and will not grow into the contaminated soil below. Species typical of Swamp Oak Floodplain Forest (SOFF) as listed within Attachment 1 are to be used and are to be locally-sourced native stock.

Primary planting (Stage 1) is to achieve the following densities of native plants:

- Shrubs – 1 per 3m² (total area of 2,800m² = 933 units)
- Grasses and groundcovers – 6 per 1m² (total area of 2,800m² = 16,800 units)

Contingency planting (Stage 2) is to be achieved at a rate of 15% of the primary planting:

- Shrubs – 145 units
- Grasses and groundcover species – 2,610 units

Estimated total number of plants

The total number of plants for the primary plantings (Stage 1) of within the bushland area is approximately:

- Trees- 43 units
- Shrubs – 1,127 units
- Grasses and groundcovers – 13,400 units
- Vines – 40 units

The total number of plants for contingency planting (Stage 2) of 15% within the bushland area is approximately:

- Trees- 6 units
- Shrubs – 169 units
- Grass and groundcovers – 2,010 units
- Vines – 6 units

The final number of plants is to be confirmed tender and approved by the project ecologist.

3.3.5 Mulching

Mulching is an efficient method to impede the establishment of weed species, soil erosion, compaction and desiccation.

To protect waterways, loose mulch should not be placed within 10m of the top of bank. Mulch under a covering of biodegradable erosion protection, such as pegged and overlapped open-weave jute mesh, is to be used for revegetation areas within 10m of the top of bank (see Figures 6 and 7).

Any native vegetation requiring removal for adjoining developments shall be immediately mulched or chipped and stockpiled on site and can be used in restoration areas beyond 10m of the top of bank, as determined by the bushland regeneration contractor. In these areas, mulch is to be placed at a depth of 75-100 mm covering any areas of replanting.

Areas surrounding the stems/trunks of plants are to be kept free from mulch, thereby reducing the incidence of collar rot on retained or planted flora.

Mulch from exotic species such as Asparagus Fern, Bitou Bush, Privet, Camphor Laurel, Coral Tree, Honey Locust, Lantana, Spider Plant, or other invasive environmental weeds are not to be used. The contractor shall ensure that any mulch used is properly composted before use and sufficient time has elapsed to allow nitrogen drawdown (up to 6 months).



Figure 6 – Example of open weave jute mesh

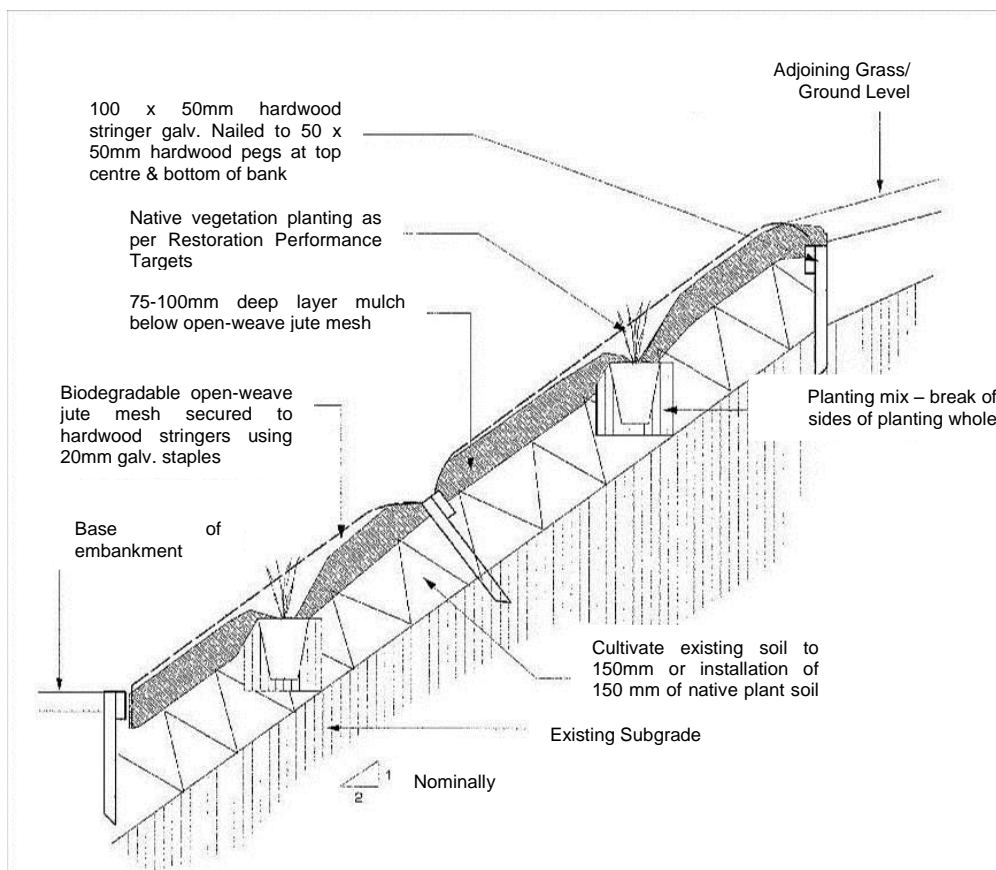

Figure 7 – Generic riparian bank stabilisation

3.3.6 Revegetation protection

Protection of revegetation areas is important to the success of plantings as to the timing and economic benefits in the long term. Protection measures include:

- Biodegradable erosion protection (e.g. pegged and overlapped open-weave jute mesh) over mulch within 10m of the top of bank – to stabilise bank and reduce soil moisture loss
- Mulching beyond 10m of the top of bank – to reduce soil moisture loss (to be avoided in areas of medium to high resilience)
- Plant guards around plants – to minimise loss by grazing animals and dehydration, and provide frost protection
- Baiting of rabbits subject to discretion of appointed project ecologist (quarterly baiting over 3 years) – use of *Pindone (1080)* to minimise rabbit burrows and grazing.

3.4 Sediment and erosion control

A sediment fence is to be installed surrounding the proposed construction areas in accordance with Landcom's *Managing Urban Stormwater: Soils and Construction* (2004). This fence is to be installed within the construction areas and not within the restoration areas. The sediment and erosion control fence is to be firmly trenched into the soil and is to assist with the minimisation of the spread of exotic plant seed into the restoration areas.

Kick-backs are to be installed along all sections of sediment fencing that run downslope to slow down any waters being directed down the fence line. The sediment fence is to be supported by fixed hay bales in low sections of the fence where concentrated runoff is directed through the fence.

Sediment and erosion controls throughout the construction area must be installed in accordance with Landcom's *'Managing Urban Stormwater: Soils and Construction'* (2004). (see Figures 8 and 9). Techniques and permanent or temporary infrastructure used for erosion and sediment control on site are to be adequately maintained and monitored at all times, particularly after periods of rain, and shall remain in proper operation until all development activities have been completed and the site is sufficiently stabilised with vegetation.

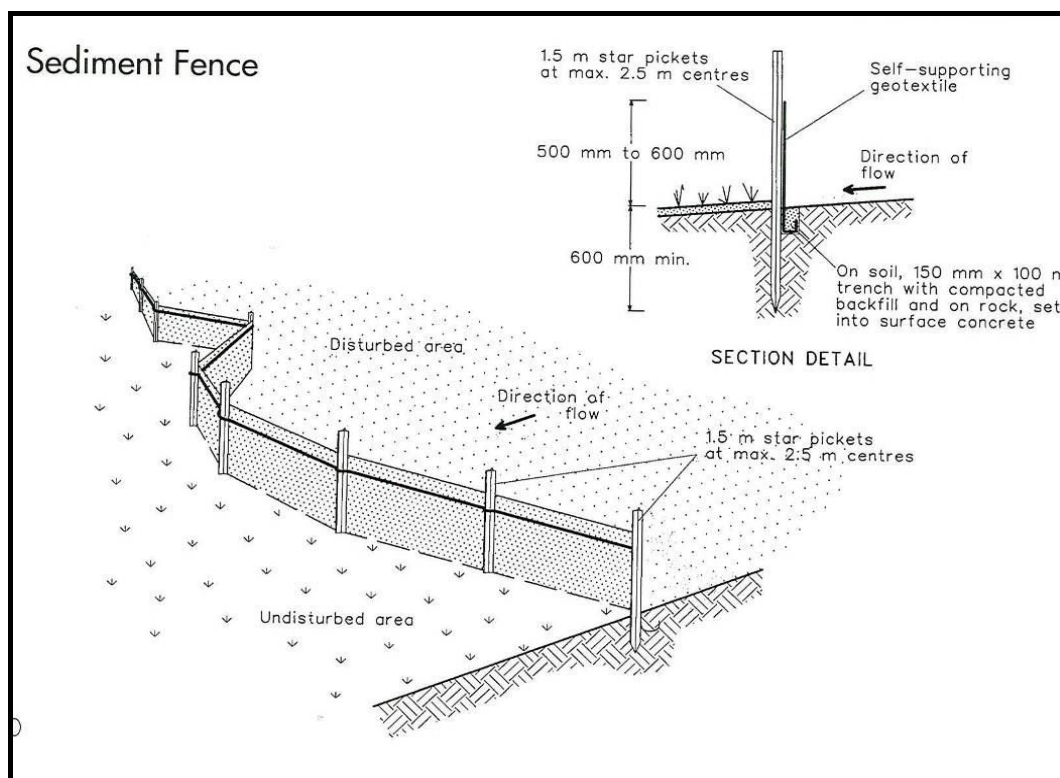

Figure 8 – Generic installation detail of geotextile filter fence

If outlet scour protection is required, it should be installed in accordance with Figure 9. The extent of scour protection is to be determined in consultation with the project ecologist but is to extend to the maximum extent of potential downstream scour. Additional plants are to be installed to assist in stabilisation of moist soils surrounding the outlet. If required, plants are to come from a local source and be typically present within the surrounding vegetation.

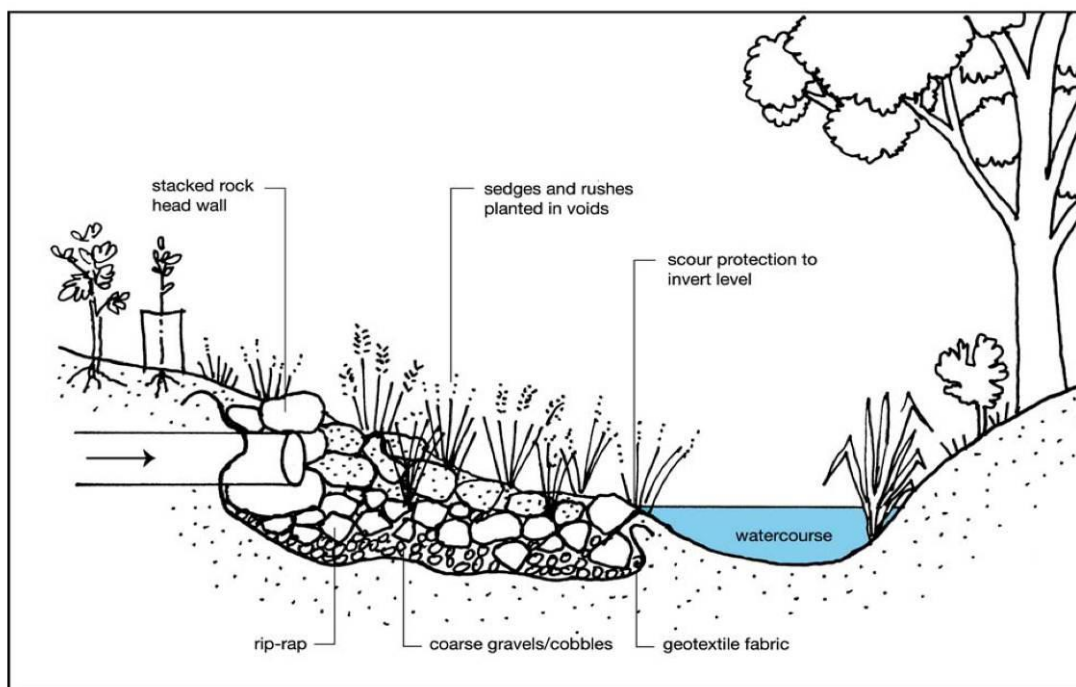

Figure 9 – Outlet scour protection

(Source – NSW DPI - Office of Water Guidelines for Controlled Activities on Waterfront Land Guidelines for Outlet Structures 2012)

3.5 Hollow-bearing trees and nest box installation

Tree hollows provide critical roosting and overnight shelter for many fauna species. Provided the trees that contain hollows are in a healthy condition, they may be considered as “Ecologically Significant” and should be retained as a high priority.

Re-locating existing hollows or installing nest boxes of similar size in nearby remaining trees can compensate for any hollow bearing trees that need to be removed for the proposed development.

A total of ten (10) nest boxes are to be installed within the bushland regeneration area in the eastern corner of the lot as shown on Schedule 1 – Vegetation Management Works. These will comprise:

- Five (5) nest boxes suitable for small birds and mammals
- Two (2) nest box suitable for large mammals / possums
- Three (3) microbat boxes

Boxes should be constructed of weatherproof timber (marine ply), fasteners and external paint and appropriately affixed to a recipient tree under the guidance of a fauna ecologist.

Nest boxes are to be installed at least 1 month prior to the commencement of tree removal works to ensure replacement roosting habitat is available.

If required, guidelines for ameliorating the loss of nesting hollows are as follows:

- I) Where possible and practical, hollow bearing limbs identified for removal should have the hollow sections collected and re-erected or installed into retained trees. Where this is not feasible, due to unstable decaying timber, artificial nest boxes providing accommodation of similar size to the removed hollows are to be erected in suitable locations.
- II) All replacement nest boxes or collected hollow limbs are to be secured to trees at a minimum height of four metres above ground level facing the east to northeast direction. Nest boxes and re-erected limbs are not to be placed near locations where public access is planned along reserve areas. All nest boxes and re-erected limbs will be inspected annually and any damaged, or in danger of falling, are to be repaired or replaced.

A fauna ecologist is to locate appropriate trees and locations for installing the nest boxes or collected hollow limbs.

A report will be supplied to Council following the completion of clearing and erection of nest boxes. This will include a plan showing the location of nest boxes and details on any fauna displaced or relocated during clearing.

At the end of the maintenance period an audit report will be provided to Council. If any of the boxes are found to be in a poor condition, these boxes will be replaced on a contingency basis.

The following guidelines are provided in the event of a hollow bearing tree that requires removal within the proposed development area.

Pre Clearing

At least one (1) weeks' notice will be needed prior to the planned date for clearing of any hollow-bearing trees. This is require to allow for suitable daytime and night time inspections of hollow-bearing trees for use by fauna and to plan for the safe felling of the tree/removal of fauna if present.

Removal of all hollow-bearing trees will be under the supervision of a suitably qualified fauna ecologist to enable effective recovery and relocation of any residing fauna. Hollow-bearing trees identified for removal are to be are to be dismantled by an arborist prior to felling the entire tree.

All hollow-bearing trees proposed for removal shall be clearly marked with an 'H' Symbol to indicate removal under supervision by a suitably qualified fauna ecologist. The contractor is to be managed such that all due care is taken to prevent damage to any trees to be retained and is not to remove the hollow-bearing trees without first receiving instruction from the fauna ecologist. A fauna ecologist is to be present at the felling or removal of each hollow-bearing tree.

After notice is given of the planned removal of trees a fauna ecologist will inspect the trees for use by fauna. This may include inspection of trees at sunset (stag watching) that allows for the detection of diurnal fauna returning to hollows or nocturnal fauna leaving for the night.

In some cases physical inspections of hollows by climbing trees may be required. This will be carried out by suitably qualified arborists under the direction and supervision of the fauna ecologist.

During Clearing

Where fauna is identified within a hollow and the risk of death or injury as a result of machine felling of the tree is high, the tree may need to be felled in sections. This will involve the removal of hollow limbs or sections by chainsaw with the hollow limb lowered to the ground for removal/relocation of fauna. These works are to be carried out by a suitably qualified arborist under the direction of the fauna ecologist.

In those trees that contain hollows and no fauna has been observed, the tree will be machine felled. Where machinery is required to fell hollow trees, the blade or bucket of the machinery will be tapped against the trunk of the tree to disturb any fauna present and provide time to leave the hollow. Several taps on the trunk and waiting periods between each set of taps may be required at the discretion of the fauna ecologist. The tree will then be felled as gently as possible. All hollow limbs will be inspected by the fauna ecologist after felling for occupation by fauna. Any fauna will be removed and relocated to adjoining bushland.

Where young fauna are identified within a hollow whose survival will be at risk as a result of the removal of the hollow or the felling of the tree, then clearing will not be carried out until those young are old enough to leave the hollow and the care of the parents. It is suggested therefore that clearing is not carried out during breeding times when young are likely to be present within hollows (spring-early summer).

Where possible, hollow limbs removed from trees will be collected by the fauna ecologist for re-erection at a later date. Any fauna injured during clearing will be handed to WIRES for care and rehabilitation, taken to a local vet for appropriate treatment, or euthanased in accordance with Animal Ethics licencing held by the fauna ecologist.

Nest box considerations are further outlined in Attachment 3.

3.5.1 Retention of hollow-bearing trees

An assessment of the location of hollow-bearing trees and the size of hollows within, was undertaken as part of the *Arboricultural Impact Assessment (Travers bushfire & ecology 2018)*. Table 2 below provides hollow-bearing tree data and Schedule 1 – Vegetation Management Works shows locations of habitat trees.

No large hollows suitable for threatened owls or cockatoos were recorded present within the study area. Some hollows recorded are considered suitable for use by threatened gliders, parrots and microbats, however no hollow-dependent threatened fauna species were recorded present during survey by *Ecoplanning*.

Table 2 – Summary of hollow-bearing trees

| Tree No | Scientific name | DBH (cm) | Spread (m) | Height (m) | Vigour (%) | Habitat tree category | Hollows & other habitat features recorded |
|---------|--------------------------------|----------|------------|------------|------------|-----------------------|---|
| T-G008 | <i>Angophora costata</i> | 21 | 4 | 10 | 70 | Cat-3 | 1x 0–5cm |
| T-G026 | Dead Stag | 45,45 | 8 | 15 | 0 | Cat-3 | 5x 0–5cm trunk cracks |
| T-G038 | Dead Stag | 44 | 3 | 12 | 0 | Cat-2 | 2x 0–5cm branch spouts |
| T-G040 | <i>Eucalyptus sclerophylla</i> | 61 | 12 | 24 | 75 | Cat-3 | 1x 5–10cm trunk hollow |
| T-G041 | <i>Eucalyptus sclerophylla</i> | 87 | 20 | 28 | 75 | Cat-3 | 2x 0–5cm branch spouts |

| Tree No | Scientific name | DBH (cm) | Spread (m) | Height (m) | Vigour (%) | Habitat tree category | Hollows & other habitat features recorded |
|---------|-----------------------------|----------|------------|------------|------------|-----------------------|---|
| T-G057 | <i>Eucalyptus piperita</i> | 120,38 | 24 | 28 | 75 | Cat-3 | 2x 0–5cm trunk & broken branch 1x 5–10cm broken branch |
| T-G066 | Dead Stag | 81 | 8 | 12 | 0 | Cat-1 | 2x 0–5cm broken branch, 2x 5–10cm broken branch, 1x 10–15cm broken branch 2x 15–20cm broken branch |
| T-G084 | Dead Stag | 47 | 6 | 18 | 0 | Cat-3 | 3x 0–5cm broken branches 1x 5–10cm branch hollow |
| T-G088 | <i>Eucalyptus piperita</i> | 110,47 | 20 | 24 | 70 | Cat-1 | 2x 0–5cm branch spouts 1x 5–10cm trunk hollow 1x 15–20cm broken branch |
| T-G123 | Dead Stag | 55 | 12 | 22 | 0 | Cat-2 | 1x 0–5cm broken branch, 2x 5–10cm broken branch, 1x 10–15cm broken branch |
| T-L001 | <i>Eucalyptus pilularis</i> | 88 | 17 | 27 | 60 | Cat-2 | 2x 5–10cm broken branch, 2x 10–15cm broken branch |
| T-L018 | <i>Eucalyptus umbra</i> | 94 | 26 | 32 | 65 | Cat-3 | 1x 5–10cm branch hollow |

The habitat trees recorded within the study area fall under one of three categories with respect to significance:

Category 1: Significant habitat trees (high):

- Large hollow suitable for cockatoos or large forest owls >30cm and/or
- Trees containing two (2) or more good quality medium hollows 10-30cm and/or
- >8 small hollows

Category 2: Significant habitat trees (moderate):

- Trees containing one medium hollow 10-30cm and/or
- 3-8 small hollows

Category 3: Remaining hollow bearing trees generally containing small or low numbers of hollows



Monitoring

4

4.1 Management of restoration works

The project manager of the site must ensure that the:

- Restoration areas are managed in accordance with this VMP, under the direction of a project restoration ecologist,
- Long term arrangements are made to ensure continuing management and maintenance of the restoration areas,
- A project restoration ecologist is engaged to independently advise and audit all vegetation management and restoration works to achieve the nominated performance targets,
- Contingency works are undertaken throughout the maintenance period to achieve the performance targets as directed by the project restoration ecologist,
- Adequate funding is provided to undertake the primary restoration works and maintenance for a minimum of three (3) years, and
- In the event of 'handover' of the restoration areas to a local authority, the reserve is handed over in a condition that would only require long term maintenance actions.

Long term arrangements for the management of the restoration areas are to be confirmed with Council.

4.2 Monitoring

Monitoring of the progress of weed removal, plant growth and natural regeneration is to be undertaken at regular intervals by the appointed project ecologist who will submit compliance statements to Council at the completion of each major item undertaken within the VMP. At the beginning of the contract, the project ecologist shall set up monitoring points at the approximate locations noted on Schedule 1 that include a photographic record prior to works being undertaken, then quadrat sampling to test the success of the works.

Contractors undertaking the revegetation and restoration works are to submit a monthly progress report to the project Ecologist along with claims for payment.

A minimum of four (4) quadrats are to be placed within the restoration areas to objectively measure the growth, diversity and density of revegetation works, and monitor weed control.

Monitoring activities will include:

1. A photographic record for comparative purposes taken on an annual basis from the same point with the same view.
2. Flora quadrats (5m x 5m) to measure the growth and density of the various revegetation areas and to monitor weed densities at selected locations within the restoration areas.
3. An overall site vegetation condition map based on standard bush regeneration vegetation condition assessment methodology.

Monitoring of the site is required to be set up prior to the commencement of revegetation works. This will allow the determination of pre and post condition of the vegetation and its habitat, and may include identification of any areas suffering from disturbance, sedimentation or in need of contingency rehabilitation, weed control, stabilisation or maintenance of rehabilitated or regenerating areas.

The monitoring and review process will focus on the presence / absence of exotic species; progress, success, structural integrity and floristic diversity of the revegetation; and monitoring of any sediment fencing or protective fencing.

Inspections of the site by the project ecologist are to be undertaken prior to, during and post restoration works to ensure that vegetated areas designated for retention and exclusion zones are adequately marked and that other appropriate protection procedures are being maintained.

An inspection is to be undertaken by the project ecologist every month during primary restoration works, with the submission of a compliance certificate at the completion of the primary and secondary weed control and revegetation works. The restoration area is to be maintained to a high standard, with no future encroachments of new landscaping beds, tree removal, installed or repaired services, driveways, fences or buildings except for that shown on Schedule 1 – Vegetation Management Works. The restoration areas is to be maintained as an indigenous native vegetation area.

Following the completion of Years 1 and 2 of the maintenance period, the project ecologist is to determine whether any additional contingency works are required to satisfactorily achieve the performance targets. These works are to be managed by land owners or under the supervision of the project ecologist.

4.3 Compliance certification

Compliance certificates will be issued by the project ecologist for the following items:

- Engagement of a bush regeneration contractor and independent project ecologist (at commencement);
- Installation of all protective fencing and sediment and erosion control measures (prior to commencement of vegetation clearance works);
- Completion of revegetation planting works at the required densities (immediately after completion of bulk earthworks);
- Completion of primary weed control works (at the end of year 1);
- Completion of secondary weed control works and revegetation maintenance (annually);
- Satisfactory achievement of restoration works as shown on Schedule 1 – Vegetation Management Works and the restoration performance targets (Section 4.5).

4.4 Funding

The proponent is to ensure sufficient funding is made available in order to cover primary restoration and maintenance costs for three (3) years in accordance with this VMP for the restoration areas. The staging of works associated with development applications are to proportionally split the costs for each stage to ensure restoration works within each stage meet the performance targets of this VMP. The funding is to include a 15% contingency for rectification works as identified by the project ecologist.

4.5 Restoration performance targets

The site audits are to assess the achievement of the following restoration performance targets:

1. All protective fencing and sediment controls are to be installed prior to the commencement of construction works.
2. Weed control and revegetation works are to be carried out by a qualified bushland regenerator to achieve the following weed control targets: maximum 10% weed coverage at the end of year 1, progressively reducing to less than 5% at the end of year 3.
3. Remediation works within the contaminated area are to be completed before the implementation of any restoration works within that area.
4. The restoration works are to achieve the following native cover performance targets of 60% at the end of year 1, 70% at the end of year 2, and 95% at the end of year 3.
5. Improved diversity and density of native vegetation over time is to be achieved.
6. The revegetation area is to be restored to a total area of 0.37ha. Plantings are to utilise a minimum of twenty five (25) locally-sourced species from the list as shown in Attachment 1. The quantity of species planted is to achieve a fully naturalised vegetation structure approved by the project ecologist.

The following densities and numbers are to be achieved:

Fully-structured revegetation area

- Canopy trees – 1 per 50m² (total area of 800m² = 16 units)
- Sub-canopy trees – 1 per 30m² (total area of 800m² = 27 units)
- Shrubs – 1 per 5m² (total area of 800m² = 160 units)
- Grasses and groundcovers – 4 per 1m² (total area of 800m² = 3,200 units)
- Vines / climbers – 1 per 20m² (total area of 800m² = 40 units)

Contaminated lands

- Shrubs – 1 per 3m² (total area of 2,800m² = 933 units)
 - Grasses and groundcovers – 6 per 1m² (total area of 2,800m² = 16,800 units)
7. Plants are to be sourced from collected native seed of local provenance. Recommended species are shown in Attachment 1.
 8. Contingency restoration works estimated at 15% of the restoration works cost, is to be undertaken at the direction of the project ecologist until the performance targets are achieved.
 9. Pest control including, but not limited to, rabbit baiting is to be undertaken throughout the restoration and maintenance period prior to, and after, planting until directed by the project ecologist to discontinue.
 10. All revegetation areas are to be stabilised; tree and shrub plants protected by cardboard boxes (2L boxes for tube stock plants) and rabbit baiting (or alternative) as approved by the project ecologist.
 11. Monitoring to be undertaken by the project ecologist with compliance certification reported to Council annually for a minimum of 3 years post primary restoration works (Section 4 of this VMP).



Program of Works

5

The program of works (Table 3) is aimed at providing a management framework for enacting revegetation, regeneration, maintenance, monitoring and review works reasonably required for the proposed restoration measures. Site rehabilitation, including weed control works is to be undertaken in accordance with Schedule 1 – Vegetation Management Works.

5.1 Program of works

For the purposes of the program of works, the listed tasks are divided into the following stages.

Pre-construction works

Pre-construction works refers to all site preparation activities prior to the commencement of any clearing or construction works on site and generally excludes any landscaping and planting works.

This stage will include the installation of protection fencing (temporary and permanent) and sediment fencing. It also includes the identification of hollow-bearing trees that may require removal and any proposed stag-watching or similar (if required), or protection if the hollow-bearing trees are to be retained.

Preparation of pest fauna management may be undertaken during this phase or prior to revegetation works commencing.

Setting up of monitoring points is vital prior to construction and clearing works to establish baseline data.

During construction works

Construction works refers to the period during which clearing, earthworks and construction of buildings, as well as roads and services being installed. It is during this period that the protection of remnant vegetation is critical to minimising accidental loss of trees or associated vegetation. It is also during this phase that primary restoration works are completed.

Primary restoration works, as defined under this VMP, include the completion of primary and secondary weed control, maintenance of protective measures, mulching and planting works.

Practical completion of the primary restoration phase is determined by the project ecologist at which point all primary restoration actions need to have been completed and the installed plants are well established, only requiring periodic maintenance or watering. Should there be a delay in the completion of works, for any reason, then the construction works phase may be extended.

Post construction works

Post construction works essentially consist of maintenance activities, unless further contingency works are identified by the project ecologist for auditing purposes. Maintenance will be undertaken by a fully qualified bush regeneration crew for a minimum of three (3) years post completion of primary restoration works.

All bush regeneration crews working on site are required to have at a minimum TAFE Certificate Level II Bush Regeneration qualifications or equivalent to undertake weeding and revegetation works. All staff are to be supervised by a qualified bush regeneration supervisor who should possess a minimum of a Certificate IV in Conservation and Land Management, or a biological science degree, with at least three (3) years of field experience.

Prior to the release of the construction certificate, all protective measures must be completed, as well as primary weed control and initial revegetation works.

Table 3 – Program of works

| Action | Responsibility |
|--|--|
| Stage 1 – Pre-construction works | |
| <ul style="list-style-type: none"> • Formation of site management team and establish supervision and consultation processes – minimum project ecologist, and site manager | <ul style="list-style-type: none"> • Site project manager |
| <ul style="list-style-type: none"> • Erection of temporary and permanent fencing, erosion control fencing | <ul style="list-style-type: none"> • Site manager / bush regenerator contractor / project ecologist |
| <ul style="list-style-type: none"> • Rabbit baiting | <ul style="list-style-type: none"> • Contractor |
| <ul style="list-style-type: none"> • Commencement of seed collection and propagation contracts | <ul style="list-style-type: none"> • Bushland regenerator / project ecologist |
| <ul style="list-style-type: none"> • Set up monitoring points | <ul style="list-style-type: none"> • Project ecologist |
| <ul style="list-style-type: none"> • Provide certificates of compliance | <ul style="list-style-type: none"> • Project ecologist |
| Stage 2 – Construction works | |
| <ul style="list-style-type: none"> • Supervision of hollow-bearing tree removal and nest box installation | <ul style="list-style-type: none"> • Fauna ecologist / tree climber |
| <ul style="list-style-type: none"> • Commencement of primary weed control | <ul style="list-style-type: none"> • Suitably qualified bushland regenerator |
| <ul style="list-style-type: none"> • Monitor erosion control measures (monthly – especially after heavy rain) and replace if required | <ul style="list-style-type: none"> • Contractor with advice of project manager |
| <ul style="list-style-type: none"> • Complete revegetation works | <ul style="list-style-type: none"> • Contractor / project manager |
| <ul style="list-style-type: none"> • Commencement of secondary weed control and maintenance weed control | <ul style="list-style-type: none"> • Contractor / project manager |
| <ul style="list-style-type: none"> • Maintenance of protective fencing | <ul style="list-style-type: none"> • Contractor / suitably qualified bushland regenerator |
| <ul style="list-style-type: none"> • Provide certificates of compliance | <ul style="list-style-type: none"> • Project ecologist |

| Stage 3 – Post-construction works | |
|---|--|
| <ul style="list-style-type: none"> • Enrichment planting within revegetation areas (if required). • Continuation of regeneration and weed control maintenance. • Monitoring of quadrats, revegetation works, weed control works and protection devices • Conduct maintenance beyond three (3) years as required • Provide certificates of compliance | <ul style="list-style-type: none"> • Contractor with advice of project ecologist • Contractor / suitably qualified bushland regenerator • Project ecologist • Site manager with advice of project ecologist • Project ecologist |

Schedule 1 identifies the location of the planned restoration and regeneration works in relation to the proposed development.

5.2 Typical timeline of restoration works

The following typical timeline (Figure 10) is provided to indicate the overall timing of restoration works. The commencement of the maintenance period of three (3) years is subject to the completion of primary restoration works as certified by the project ecologist. A certificate of completion will be required as evidence of satisfactory results.

The successful implementation of restoration works may affect the release of the occupation certificate or the release of any required bonds as required under the development consent. Therefore contingency restoration works may be required in order for a compliance certificate to be issued.

Upon engagement, contractors are expected to meet the following typical schedule of works:



Recommended Planting List

A1

The following locally occurring native plant species are to be established within the revegetation area. Further species will also be suitable as approved by the project ecologist provided that they are recognised as being typical or common species known or demonstrated to occur within Smooth-barked Apple - Red Bloodwood open forest and Swamp Oak Floodplain Forest. The appointed bush regeneration contractor may vary the number of plant species to be established provided 80% dominant species is retained as per this Attachment 1.

For the purposes of those species listed below, trees are generally 8m or taller in height, shrubs are typically 1-8m in height and ground covers, which include grasses, herbs, small shrubs and vines, are up to 1m in height.

Table A1 – Recommended planting list for restoration zone

| SMOOTH-BARKED APPLE - RED BLOODWOOD OPEN FOREST | | |
|---|------------------------------------|-------------------------------|
| Canopy trees: 1 per 50m² | | |
| <i>Angophora costata</i> | <i>Eucalyptus globoidea</i> | <i>Eucalyptus resinifera</i> |
| <i>Corymbia gummifera</i> | <i>Eucalyptus pilularis</i> | <i>Syncarpia glomulifera</i> |
| <i>Eucalyptus sclerophylla</i> | <i>Eucalyptus piperita</i> | |
| Sub-canopy trees: 1 per 30m² | | |
| <i>Acacia parramattensis</i> | <i>Elaeocarpus reticulatus</i> | <i>Xylomelum pyriforme</i> |
| <i>Allocasuarina littoralis</i> | <i>Melaleuca linariifolia</i> | |
| Shrubs: 1 per 5m² | | |
| <i>Acacia linifolia</i> | <i>Dodonaea triquetra</i> | <i>Persoonia pinifolia</i> |
| <i>Acacia longifolia</i> | <i>Grevillea buxifolia</i> | <i>Persoonia linearis</i> |
| <i>Acacia suaveolens</i> | <i>Grevillea sericea</i> | <i>Persoonia levis</i> |
| <i>Acacia ulicifolia</i> | <i>Kunzea ambigua</i> | <i>Polyscias sambucifolia</i> |
| <i>Bossiaea obcordata</i> | <i>Leptospermum trinervium</i> | <i>Pultenaea flexilis</i> |
| <i>Breynia oblongifolia</i> | <i>Leptospermum polygalifolium</i> | <i>Woolfsia pungens</i> |
| <i>Bursaria spinosa</i> subsp. <i>spinosa</i> | <i>Ozothamnus diosmifolius</i> | <i>Zieria pilosa</i> |
| Ground covers: 4 per 1m² | | |
| <i>Aristida vagans</i> | <i>Dipodium variegatum</i> | <i>Microlaena stipoides</i> |
| <i>Austrostipa pubescens</i> | <i>Entolasia marginata</i> | <i>Oplismenus aemulus</i> |
| <i>Blechnum cartilagineum</i> | <i>Entolasia stricta</i> | <i>Oplismenus imbecillis</i> |
| <i>Centella asiatica</i> | <i>Imperata cylindrica</i> | <i>Themeda triandra</i> |
| <i>Dianella caerulea</i> | <i>Lomandra longifolia</i> | |
| Vines / climbers: 1 per 20m² | | |
| <i>Hardenbergia violacea</i> | <i>Pandorea pandorana</i> | <i>Smilax glycyphylla</i> |
| SWAMP OAK FLOODPLAIN FOREST | | |
| Shrubs: 1 per 5m² | | |
| <i>Breynia oblongifolia</i> | <i>Dodonaea triquetra</i> | <i>Myoporum acuminatum</i> |
| <i>Bursaria spinosa</i> subsp. <i>spinosa</i> | <i>Melaleuca thymifolia</i> | <i>Trema tomentosa</i> |

| Ground covers: 4 per 1m ² | | |
|--------------------------------------|--------------------------------|------------------------------|
| <i>Aristida vagans</i> | <i>Echinopogon caespitosus</i> | <i>Lomandra longifolia</i> |
| <i>Austrostipa pubescens</i> | <i>Entolasia marginata</i> | <i>Microlaena stipoides</i> |
| <i>Blechnum indicum</i> | <i>Ficinia nodosa</i> | <i>Oplismenus imbecillis</i> |
| <i>Centella asiatica</i> | <i>Gahnia clarkei</i> | <i>Themeda triandra</i> |
| <i>Commelina cyanea</i> | <i>Imperata cylindrica</i> | |
| <i>Dianella caerulea</i> | <i>Juncus usitatus</i> | |



Target Weed Species

A2

The following weed species occur on site and are to be targeted on a priority basis subject to degree of invasiveness and implications for regeneration of native flora.

Table A2 – Target weed species for the site

| Species | Common name | Priority |
|--|----------------------------|-----------|
| <i>Asparagus aethiopicus</i> | Ground Asparagus | Very High |
| <i>Cinnamomum camphora</i> | Camphor Laurel | Very High |
| <i>Cortaderia</i> sp. | Pampas Grass | Very High |
| <i>Lantana camara</i> | Lantana | Very High |
| <i>Ligustrum lucidum</i> | Large-leaved Privet | Very High |
| <i>Ligustrum sinense</i> | Small-leaved Privet | Very High |
| <i>Olea europaea</i> subsp. <i>cuspidata</i> | African Olive | Very High |
| <i>Robinia pseudoacacia</i> | Black Locust | Very High |
| <i>Rubus fruticosus</i> | Blackberry | Very High |
| <i>Sporobolus fertilis</i> | Giant Parramatta Grass | Very High |
| <i>Ageratina adenophora</i> | Crofton Weed | High |
| <i>Arundo donax</i> | Giant Reed | High |
| <i>Cenchrus clandestinus</i> | Kikuyu Grass | High |
| <i>Ehrharta erecta</i> | Panic Veldtgrass | High |
| <i>Eragrostis curvula</i> | African Lovegrass | High |
| <i>Festuca</i> sp. | | High |
| <i>Genista monspessulana</i> | Montpellier Broom | High |
| <i>Melinis repens</i> | Red Natal Grass | High |
| <i>Nephrolepis cordifolia</i> | Fishbone Fern | High |
| <i>Ochna serrulata</i> | Mickey Mouse Plant | High |
| <i>Paspalum dilatatum</i> | Paspalum | High |
| <i>Paspalum urvillei</i> | Vasey Grass | High |
| <i>Passiflora suberosa</i> | Cork Passionflower | High |
| <i>Senna pendula</i> var. <i>glabrata</i> | | High |
| <i>Sporobolus africanus</i> | Parramatta Grass | High |
| <i>Stenotaphrum secundatum</i> | Buffalo Grass | High |
| <i>Acacia saligna</i> | Golden Wreath Wattle | Moderate |
| <i>Axonopus fissifolius</i> | Narrow-leaved Carpet Grass | Moderate |
| <i>Chloris gayana</i> | Rhodes Grass | Moderate |
| <i>Chlorophytum comosum</i> | Spider Plant | Moderate |
| <i>Cotoneaster</i> sp. | | Moderate |
| <i>Melilotus officinalis</i> | Common Melilot | Moderate |
| <i>Ricinus communis</i> | Castor Oil Plant | Moderate |
| <i>Senecio madagascariensis</i> | Fireweed | Moderate |
| <i>Setaria parviflora</i> | | Moderate |
| <i>Sida rhombifolia</i> | Paddy's Lucerne | Moderate |
| <i>Solanum mauritianum</i> | Wild Tobacco | Moderate |

| Species | Common name | Priority |
|--------------------------------|------------------------------|----------|
| <i>Trifolium repens</i> | White Clover | Moderate |
| <i>Verbena bonariensis</i> | Purpletop | Moderate |
| <i>Verbena officinalis</i> | Common Verbena | Moderate |
| <i>Acetosa sagittata</i> | Turkey Rhubarb | Low |
| <i>Arenaria serpyllifolia</i> | Lesser Thyme-leaved Sandwort | Low |
| <i>Bidens pilosa</i> | Cobblers Pegs | Low |
| <i>Briza</i> spp. | Quaking Grass | Low |
| <i>Bromus catharticus</i> | Prairie Grass | Low |
| <i>Centaurium erythraea</i> | Common Centaury | Low |
| <i>Chenopodium album</i> | Fat Hen | Low |
| <i>Cirsium vulgare</i> | Spear Thistle | Low |
| <i>Conyza bonariensis</i> | | Low |
| <i>Digitaria sanguinalis</i> | Summer Grass | Low |
| <i>Euphorbia peplus</i> | Petty Spurge | Low |
| <i>Foeniculum vulgare</i> | Fennel | Low |
| <i>Gamochaeta</i> sp. | | Low |
| <i>Gomphocarpus fruticosus</i> | Narrow-leaved Cotton Bush | Low |
| <i>Hirschfeldia incana</i> | Hairy Brassica | Low |
| <i>Hypochaeris radicata</i> | Catsear | Low |
| <i>Lactuca serriola</i> | Prickly Lettuce | Low |
| <i>Lolium</i> sp. | | Low |
| <i>Lotus</i> sp. | | Low |
| <i>Lysimachia arvensis</i> | Scarlet Pimpernel | Low |
| <i>Malva parviflora</i> | Small-flowered Mallow | Low |
| <i>Modiola caroliniana</i> | Red-flowered Mallow | Low |
| <i>Morus alba</i> | White Mulberry | Low |
| <i>Nothoscordum gracile</i> | Onion Weed | Low |
| <i>Oenothera stricta</i> | | Low |
| <i>Plantago lanceolata</i> | Lamb's Tongue | Low |
| <i>Solanum nigrum</i> | Black-berry Nightshade | Low |
| <i>Sonchus oleraceus</i> | | Low |
| <i>Taraxacum officinale</i> | Dandelion | Low |
| <i>Trifolium campestre</i> | Hop Clover | Low |
| <i>Verbascum thapsus</i> | Great Mullein | Low |
| <i>Vicia sativa</i> | | Low |



Nest Box Specifications

A3

1 Nest boxes for use by arboreal mammals, diurnal birds and microbats

The following nest box designs are provided by *Travers bushfire & ecology* as a guide for construction of nest boxes for arboreal mammals, diurnal birds and microbats. It is based on a variety of information sources and current project experience in the construction and installation of nest boxes.

The following design parameters are important to ensure the design is robust, the attachment to trees remains secure and use by wildlife is appropriate all for the long-term. These specifications will incur subsequent additional costs to ensure the longevity of the box, this expense will be more cost effective in the long-term as boxes (if built correctly) can be built to last for more than three times longer.

1.1 Minimum design requirements

The nest boxes are to be built in the following manner:

- Timber is to be of high grade ply 15 mm thick – MDF, particle board and low grade ply are not acceptable.
- The lid is to be hinged at the rear side of the box that is affixed to the tree to allow internal inspections from the front side. Lids are to be well sloped to the front to allow runoff by rain. Hinges are to be robust (not small) and made of brass, stainless steel or galvanised. Lids are to be larger than the overall cross sectional size of the box and placed so that a small eave exists on all sides to prevent entry of rain.
- Two vertical timber supports (approximately 30x30mm timber strips 150 mm apart) are to be attached down the rear face of the box so that there are two points of attachment to the trunk on a curved surface and the box does not rock in the wind. This will also provide easy attachment points to the trees without having to screw through the inside of the box. These are to be made of treated pine and any screws into this (for hinges etc.) should be treated pine or stainless. Holes at both ends of both supports are to be predrilled for easy attachment to trees. Timber supports should not be placed directly onto the box but with small timber spacers so that an eave is permissible along this side of the roof.
- Boxes to be constructed for a target species. Recommended dimensions of nest boxes for select fauna species are supplied in Table 1 below. Entry holes are best placed in the front for birds or the sides for arboreal mammals.
- For bird boxes, an anti-myna baffle (illustrated below) or steeply sloped roof with side excluders should be placed to prevent direct front access to the entry hole. This is to prevent use and dominance by the exotic Common Myna or Starlings.

- Bird boxes should allow the wall to be climbed from the entry hole down to the base. This may be achieved by depth controlled saw cuts, robust matting or a ladder. Boxes with anti-myna baffle may require the same placed below the hole on the external front.
- Joints are to be glued and screwed for strength. Glue should be labelled as non-toxic wood glue.
- All fasteners used are to be weather resistant stainless steel, galvanised or other. Screws into the treated pine supports are to be stainless steel or treated pine screws.
- All fasteners for tree attachment are to be supplied (stainless steel or treated pine coach screws). These are to be a suitable gauge depending the size of bow and suitable length to pass through the vertical timber supports, through the bark and cambium, and into a sufficient extent of heartwood. Heartwood penetration will depend on the size of the box. Screws for small boxes should extend a minimum of 20mm into the heartwood of hardwood eucalypts and medium boxes ~40mm. All boxes are to be screwed so that a small distance for growth exists between the timber supports and the trunk. This can be achieved with a small stainless sleeve over the screw.
- 5 mm drainage holes are to be drilled in each corner at the base.
- Exterior of the boxes (including treated pine supports) are to be painted with a primer and then a minimum of two coats of external non-alcohol based acrylic paint. The colour selected should be consistent with the colour of the recipient trunk and therefore recipient trees should ideally be prior selected.

Note: Different methods of attachment to the tree are available. *Travers bushfire & ecology* generally recommends that the boxes should be fixed with robust stainless steel or treated pine coach screws that penetrate through the cambium and into the heartwood of the tree to ensure a very secure attachment. Provided that any cambium damage to a tree is not left as an open wound then the chance of fungal infection or insect attack is significantly reduced and the tree will grow around the screw. Any other method of attachment selected should also ensure the box is secured to prevent movement or fall and allows for the future growth of the tree without any cambium constriction over the complete life of the box.

1.2 Nest box placement requirements

- The larger and more mature the recipient tree are to be selected where available. This will comparatively reduce the weighted stress on the tree, make the box less visible and result in less change in growth ratio affecting the selected attachment method.
- Nest box is preferably to be placed on the trunk for structural stability and protection from falling branches.
- Place nest boxes as high as physically possible within a tree preferably using a cherry picker or tree climber. This is certainly the case for birds (including owls) but not so much necessary for gliders. Microbat species vary but generally the higher the better for consideration to most species.
- Place nest boxes away from continual direct mid-day summer sun (on the edge of clearings) and preferably on the southern side of the trunk.
- Place nest boxes with large entry holes away from any prevailing winds when close to open water-bodies. E.g. protect from strong southerly winds close to the ocean and contrastingly cool-hot westerly winds in different seasons.

- Attached nest boxes securely so that they do not shift or shake in response to strong winds or being knocked by the movements of heavier animals, e.g. Possums and goannas.
- To ensure nest boxes are inaccessible to cats and rats or to also assist target species by exclusion of possums, the base of trunk or branches may also installation of tree guards or exclusion collars.
- Nest boxes should ideally be placed accessible for management but concealed from interference.

1.3 Management of installed boxes

- Deterring Mynas and Starlings from re-nesting is not easy; these pests are very persistent, and constant vigilance is necessary. This also means that you must have convenient regular access to the nest-box, and that you must be aware of what creatures are using it for what purposes.
- Nest boxes found to be utilised by threatened or otherwise significant fauna may be prioritised for ongoing management to ensure their longevity and replicate their design/placement characteristics.

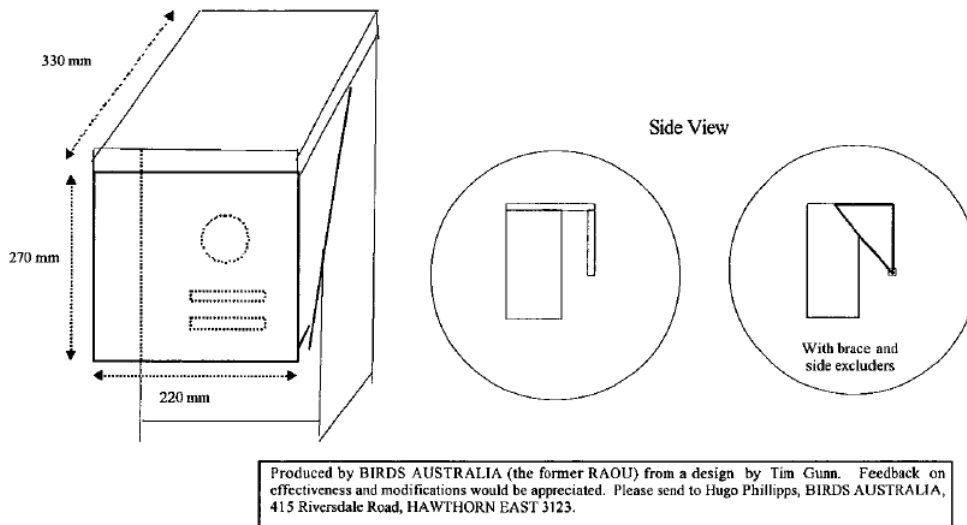
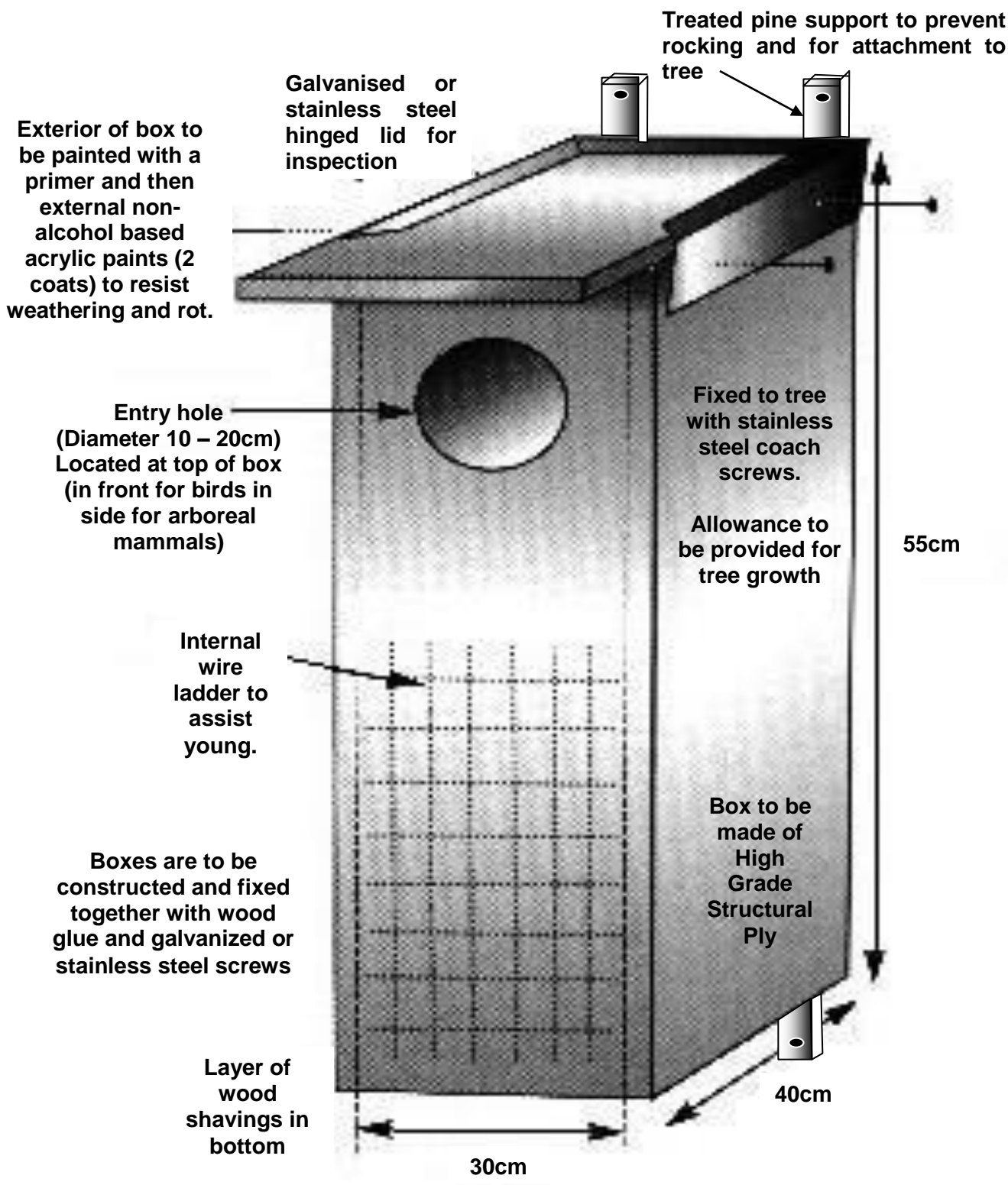

Diagram 1 - Anti-Myna Baffle

(Sourced from *Birds Australia Information Sheet No.5 – 30 July 2001*).



DESIGN 1 - PARROT & ARBOREAL MAMMAL NEST BOX DETAIL

Note: For dimensions of other target species see Table 1.
 (Size dimensions applied for a Large Parrot Box)

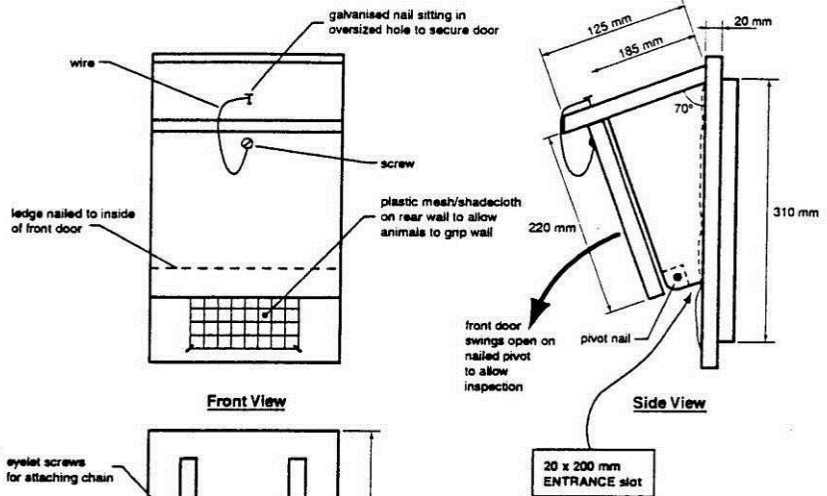

Fixed to tree with stainless steel coach screws.

Allowance to be provided for tree growth

OPTION

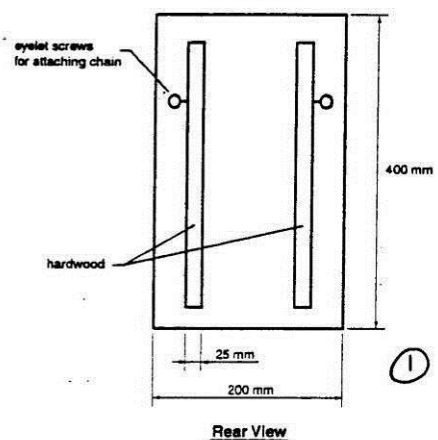

Exterior of box to be painted with a primer and then 2 coats of external non-alcohol based acrylic paint to resist weathering and rot.

OPTION 2

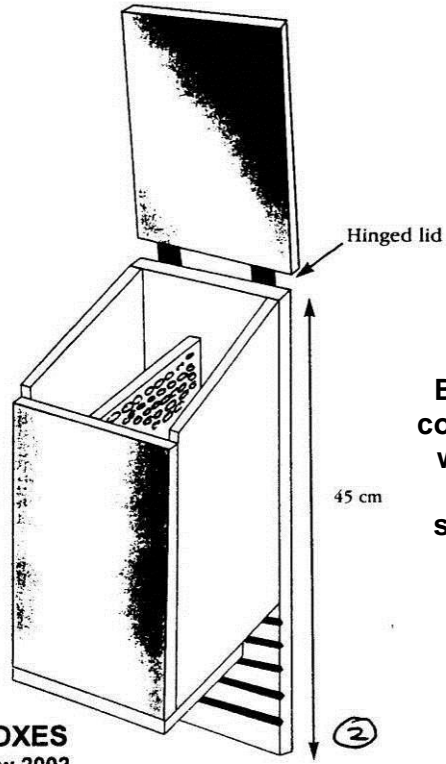

Box to be constructed with high grade structural ply

BAT ROOSTING BOXES
 1. From Smith and Agnew 2002
 2. From Gould League of Victoria 1997

DESIGN 2 - MICROBAT NEST BOX DETAIL (Option 1 & 2)
 Note: Alternative designs available for alternative mounts



Photo 1 - Example of microbat design. Note: these boxes are not painted or appropriately affixed to the tree.

The following internal and external dimensions are recommended for the list of species. In choosing the ideal size boxes and openings the advice of an experienced Restoration Ecologist is to be sought.

Table 1 - Recommended Nest Box Dimensions for typical fauna
(Source: *Birds Australia Supplement No. 5 – Nest Boxes for Natives*)

| SPECIES | INT DIAM | DEPTH/LENGTH | ENT DIAM | VERT/HOR | HEIGHT | SEASON | REF |
|-----------------------------|----------------------|--------------|---------------|----------|--------|----------|-----------------|
| Antechinus, Yellow-footed | - | - | 20-25 mm | - | - | - | Trainor (1995) |
| Bat sp. | 70-100 x 150-240 mm | 200-250 mm | 15-20 mm slit | v | - | - | BFNC (n.d.) |
| Bat, Chocolate Wattled | - | - | 10 mm slit | - | - | - | Trainor (1995) |
| Bat, Gould's Wattled | - | - | 10 mm slit | - | - | - | Trainor (1995) |
| Bat, Lesser Long-eared | - | - | 10 mm slit | - | - | - | Trainor (1995) |
| Black-Cockatoo, Glossy | 300 mm | 870-1000 mm | 160 x 200 mm | v | - | - | Pedler (1996) |
| Boobook, Southern | - | - | 150 mm | h | - | - | Trainor (1995) |
| Brush-tail-Possum sp. | 320 mm | 400 mm | 120-150 mm | v | 4-8 m | Autumn | MZES (n.d.) |
| Brush-tail-Possum sp. | 210 x 240 mm | 380 mm | c.120 mm | v | - | - | RSPCA (n.d.) |
| Brush-tail-Possum sp. | - | - | 90 mm | - | - | - | Trainor (1995) |
| Cockatoo, Sulphur-crested | - | - | 150 mm | v | - | - | Trainor (1995) |
| Corella, Little | - | - | 150 mm | - | - | - | Trainor (1995) |
| Corella, Long-billed | - | - | 150 mm | - | - | - | Trainor (1995) |
| Duck, Australian Wood | 200 mm | 500 mm | 120 mm | v | - | - | Trainor (1995) |
| Duck, Pacific Black | 450 x 300 mm | - | 120 mm | - | - | - | Elliot (1994) |
| Duck, Pacific Black | - | - | 120 mm | h | - | - | Trainor (1995) |
| Duck, Pink-eared | - | - | - | - | - | - | Elliot (1994) |
| Galah | 200 mm | 650 mm | 120 mm | v | 6 m | Aug-Nov | Adams (1980) |
| Galah | 200 mm | 650 mm | 120 mm | v | 6 m | Sep-Jan | MZES (n.d.) |
| Galah | - | - | 150 mm | - | - | - | Trainor (1995) |
| Glider, Feather-tailed | - | - | 20-25 mm | - | - | - | Trainor (1995) |
| Glider, Squirrel | - | - | 60 mm | - | - | - | Trainor (1995) |
| Glider, Sugar | 250 mm | 300 mm | 50 mm | v | 4-8 m | Jun-Dec | MZES (n.d.) |
| Glider, Sugar | 200 mm | 450 mm | 35-40 mm | v | - | - | BFNC (n.d.) |
| Glider, Sugar | - | - | 25-30 mm | - | - | - | Trainor (1995) |
| Kestrel, Nankeen | 400 mm | 750 mm | 100 mm | v | 5 m | Aug-Nov | Adams (1980) |
| Kingfisher, Sacred | 130 mm | 600-900 mm | 75 mm | h | 5-10 m | Sep-Mar | Adams (1980) |
| Kookaburra sp. | 300 mm | 500 mm | >130 mm | h | 5-10 m | Sep-Jan | Adams (1980) |
| Kookaburra sp. | 400 mm | - | 130 mm | h | 5-10 m | Sep-Jan | MZES (n.d.) |
| Kookaburra sp. | 300 x 150-200 mm | 600 mm | open | h | - | - | BFNC (n.d.) |
| Kookaburra, Laughing | 150-300 mm | >400 mm | 80-120 mm | h | - | - | Elliot (1994) |
| Kookaburra, Laughing | - | - | 120 mm | h | - | - | Trainor (1995) |
| Lorikeet sp. | 120 mm | 600 mm | 60 mm | h | 5 m | Aug-Jan | Adams (1980) |
| Lorikeet, Little | - | - | 25-30 mm | - | - | - | Trainor (1995) |
| Lorikeet, Musk | - | - | 25-30 mm | - | - | - | Trainor (1995) |
| Lorikeet, Purple-crowned | - | - | 25-30 mm | - | - | - | Trainor (1995) |
| Owl, Barn | 400 mm | 750 mm | open | h | 5 m | Aut-Spr | Adams (1980) |
| Owl, Barn | - | - | 150 mm | h | - | - | Trainor (1995) |
| Owlet-nightjar, Australian | 100-150 mm | 300-350 mm | 60-80 mm | v | 5 m | Sep-Dec | Adams (1980) |
| Owlet-nightjar, Australian | 150 mm | >150 mm | 70-120 mm | v | - | - | Elliot (1994) |
| Owlet-nightjar, Australian | 150 mm | 400 mm | 50 mm | v | - | Sep-Dec | BFNC (n.d.) |
| Owlet-nightjar, Australian | - | - | 40 mm | - | >5 m | - | Trainor (1995) |
| Owlet-nightjar, Australian | - | - | 25-30 mm | - | - | - | Trainor (1995) |
| Pardalote sp. | 120 mm | 400-500 mm | 30-45 mm | h | 5 m | Jul-Jan | Adams (1980) |
| Pardalote sp. | 120 mm | 450 mm | 30-45 mm | h | 5 m | Jul-Jan | MZES (n.d.) |
| Pardalote, Striated | 200 x 120-150 mm | - | 25-35 mm | v/h | - | - | Elliot (1994) |
| Pardalote, Striated | 90 x 120-140 mm | 200 mm | 30 mm | h | - | Aug-Feb | BFNC (n.d.) |
| Parrot, Red-rumped | 100 mm | 600 mm | 75 mm | v/h | 5 m | Aug-Jan | Adams (1980) |
| Parrot, Red-rumped | 100-150 mm | 400 mm | 70-120 mm | h | - | - | Elliot (1994) |
| Parrot, Red-rumped | 200-240 mm | 400 mm | 60-70 mm | v | - | - | BFNC (n.d.) |
| Parrot, Red-rumped | - | - | 25-30 mm | - | - | - | Trainor (1995) |
| Phascogale, Brush-tailed | - | - | 25-30 mm | - | - | - | Trainor (1995) |
| Ringtail-Possum sp. | 250 mm | 350 mm | 80 mm | v | 4-8 m | Apr-Nov | MZES (n.d.) |
| Ringtail-Possum sp. | 250 mm | 400 mm | 60-80 mm | v | - | Mar-Nov | BFNC (n.d.) |
| Ringtail-Possum sp. | - | - | 90 mm | - | - | - | Trainor (1995) |
| Rosella sp. | 120-150 mm | >400 mm | 70-120 mm | - | - | - | Elliot (1994) |
| Rosella sp. | 150-200 mm | 350-800 mm | 75-100 mm | v/h | 5 m | Aug-Jan | MZES (n.d.) |
| Rosella sp. | c.130 x 180 mm | c.400 mm | 80 mm | v | - | - | Morrison (1996) |
| Rosella, Crimson | 150-200 mm | 350-800 mm | 75-100 mm | v/h | 5-6 m | Sep-Jan | Adams (1980) |
| Rosella, Eastern | 135-150 mm | 350-800 mm | 75-100 mm | v/h | 5-6 m | Aug-Jan | Adams (1980) |
| Rosella, Eastern | 240 mm | 400 mm | 70 mm | v | - | - | BFNC (n.d.) |
| Rosella, Eastern | - | >500 mm | 60 mm | - | >5 m | - | Trainor (1995) |
| Shrike-thrush, Grey | 150-200 mm | 200-300 mm | 150 mm | - | - | - | Elliot (1994) |
| Shrike-thrush, Grey | 150-200 x 200-300 mm | 150-200 mm | open | h | - | - | BFNC (n.d.) |
| Swallow, Welcome | 130 mm | - | open | h | 3 m | Aug-Dec | Adams (1980) |
| Teal, Chestnut | 200-400 mm | 450-750 mm | 100-120 mm | v | 1.5 m | Sep-Dec | Adams (1980) |
| Teal, Chestnut | 450 x 300 mm | - | 80-100 mm | - | - | - | Elliot (1994) |
| Teal, Grey | 200-400 mm | 450-750 mm | 100-120 mm | v | 1.5 m | All year | Adams (1980) |
| Teal, Grey | 450 x 300 mm | - | 80-100 mm | - | - | - | Elliot (1994) |
| Teal, Grey | - | - | 90 mm | - | - | - | Trainor (1995) |
| Treecreeper sp. | 90-150 mm | 100-150 mm | 50-80 mm | v | - | - | Elliot (1994) |
| Treecreeper sp. | 150 mm | 400 mm | 50 mm | v | - | - | BFNC (n.d.) |
| Treecreeper, White-throated | 75-100 mm | 300-400 mm | 50-70 mm | v | 5 m | Aug-Jan | Adams (1980) |

2.0 Pest Fauna Control

Typical pests of nest boxes include Starlings, Indian minors and the common honey bee. In all cases the pest fauna competes with available roosting sites and may alter the boxes to meet their own requirements.

All nest boxes are to be erected at a minimum height of 4m above ground height to minimise the risk of damage and predation by exotic and pest fauna.

All nest boxes are to be checked on a quarterly basis for pest fauna during maintenance runs and removed if present. The removal of bees is to be handled by an experienced apiarist or registered pest control officer. No residual chemicals are to be used and a fully operational nest box is to be re-installed.

Hinged inspection hatches are to be provided for all nest boxes allow the boxes to be checked for occupation. The method of attachment is to allow removal of the nest box for maintenance or replacement as required.

3.0 Maintenance and Replacement Nest Boxes

Maintenance of nest boxes should be undertaken on a 6 monthly basis. Any nest boxes that are damaged (as identified by visual inspection) will be replaced and or immediately repaired. The removal or replacement of the box will be delayed if nesting fauna are present until the young have left the nest. Nest Boxes that are at risk of detachment are to be secured immediately.

Replacement boxes are to be installed if the existing box is permanently damaged or beyond repair. An equivalent quality or better will be installed as a replacement. The design specifications are to be adhered to strictly unless a qualified fauna ecologist approves an alternative design of better performance.

Maintenance inspections are undertaken to check the condition of nest boxes and their support structures. During inspection runs, damaged boxes must be removed, a replacement box immediately installed and the damaged box retained for minor repairs.

Other additional maintenance tasks may include re securing boxes, restocking with wood shavings and the removal of pest fauna species.



Vegetation Management Works

S1

- Restoration performance targets**
- All protective fencing and sediment controls are to be installed prior to the commencement of construction works.
 - Weed control and revegetation works are to be carried out by a qualified bushland regenerator to achieve the following weed control targets: maximum 10% weed coverage at the end of year 1, progressively reducing to less than 5% at the end of year 3.
 - Remediation works within the contaminated area are to be completed before the implementation of any restoration works within that area.
 - The restoration works are to achieve the following native cover performance targets of 60% at the end of year 1, 70% at the end of year 2, and 95% at the end of year 3.
 - Improved diversity and density of native vegetation over time is to be achieved.
 - The revegetation area is to be restored to a total area of 0.37ha. Plantings are to utilise a minimum of twenty five (25) locally-sourced species from the list as shown in Attachment 1. The quantity of species planted is to achieve a fully naturalised vegetation structure approved by the project ecologist.
- The following densities and numbers are to be achieved:
- Fully-structured revegetation area**
- Canopy trees – 1 per 50m² (total area of 800m² = 16 units)
 - Sub-canopy trees – 1 per 30m² (total area of 800m² = 27 units)
 - Shrubs – 1 per 5m² (total area of 800m² = 160 units)
 - Grasses and groundcovers – 4 per 1m² (total area of 800m² = 3,200 units)
 - Vines / climbers – 1 per 20m² (total area of 800m² = 40 units)
- Contaminated lands**
- Shrubs – 1 per 3m² (total area of 2,800m² = 933 units)
 - Grasses and groundcovers – 6 per 1m² (total area of 2,800m² = 16,800 units)
- Plants are to be sourced from collected native seed of local provenance. Recommended species are shown in Attachment 1.
 - Contingency restoration works estimated at 15% of the restoration works cost, is to be undertaken at the direction of the project ecologist until the performance targets are achieved.
 - Pest control including, but not limited to, rabbit baiting is to be undertaken throughout the restoration and maintenance period prior to, and after, planting until directed by the project ecologist to discontinue.
 - All revegetation areas are to be stabilised; tree and shrub plants protected by cardboard boxes (2L boxes for tube stock plants) and rabbit baiting (or alternative) as approved by the project ecologist.
 - Monitoring to be undertaken by the project ecologist with compliance certification reported to Council annually for a minimum of 3 years post primary restoration works (Section 4 of this VMP).

SMOOTH-BARKED APPLE - RED BLOODWOOD OPEN FOREST - Fully Structured

Canopy trees: 1 per 50m²

| | | |
|--------------------------------|-----------------------------|------------------------------|
| <i>Angophora costata</i> | <i>Eucalyptus globoidea</i> | <i>Eucalyptus resinifera</i> |
| <i>Corymbia gummifera</i> | <i>Eucalyptus pilularis</i> | <i>Syncarpia glomulifera</i> |
| <i>Eucalyptus sclerophylla</i> | <i>Eucalyptus piperita</i> | |

Sub-canopy trees: 1 per 30m²

| | | |
|---------------------------------|--------------------------------|-----------------------------|
| <i>Acacia paramattensis</i> | <i>Elaeocarpus reticulatus</i> | <i>Xylocarpus pyriforme</i> |
| <i>Allocasuarina littoralis</i> | <i>Melaleuca linariifolia</i> | |

Shrubs: 1 per 5m²

| | | |
|--|------------------------------------|-------------------------------|
| <i>Acacia linifolia</i> | <i>Dodonaea triquetra</i> | <i>Persoonia pinifolia</i> |
| <i>Acacia longifolia</i> | <i>Grevillea buxifolia</i> | <i>Persoonia linearis</i> |
| <i>Acacia suaveolens</i> | <i>Grevillea sericea</i> | <i>Persoonia levis</i> |
| <i>Acacia ulicifolia</i> | <i>Kunzea ambigua</i> | <i>Polyscias sambucifolia</i> |
| <i>Bossiaea obcordata</i> | <i>Leptospermum trinervium</i> | <i>Pultenaea flexilis</i> |
| <i>Breynia oblongifolia</i> | <i>Leptospermum polygalifolium</i> | <i>Woolisia pungens</i> |
| <i>Bursaria spinosa</i> subsp. <i>spinosa</i> | <i>Ozothamnus diosmifolius</i> | <i>Zieria pilosa</i> |

Ground covers: 4 per 1m²

| | | |
|-------------------------------|----------------------------|------------------------------|
| <i>Aristida vagans</i> | <i>Dipodium variegatum</i> | <i>Microlaena stipoides</i> |
| <i>Austrostipa pubescens</i> | <i>Entolasia marginata</i> | <i>Oplismenus aemulus</i> |
| <i>Blechnum cartilagineum</i> | <i>Entolasia stricta</i> | <i>Oplismenus imbecillis</i> |
| <i>Centella asiatica</i> | <i>Imperata cylindrica</i> | <i>Themeda triandra</i> |
| <i>Dianella caerulea</i> | <i>Lomandra longifolia</i> | |

Vines / climbers: 1 per 20m²

| | | |
|------------------------------|---------------------------|---------------------------|
| <i>Hardenbergia violacea</i> | <i>Pandorea pandorana</i> | <i>Smilax glyciphylla</i> |
|------------------------------|---------------------------|---------------------------|

SWAMP OAK FLOODPLAIN FOREST - Contaminated land

Shrubs: 1 per 5m²

| | | |
|--|-----------------------------|----------------------------|
| <i>Breynia oblongifolia</i> | <i>Dodonaea triquetra</i> | <i>Myoporum acuminatum</i> |
| <i>Bursaria spinosa</i> subsp. <i>spinosa</i> | <i>Melaleuca thymifolia</i> | <i>Trema tomentosa</i> |

Ground covers: 4 per 1m²

| | | |
|------------------------------|--------------------------------|------------------------------|
| <i>Aristida vagans</i> | <i>Echinopogon caespitosus</i> | <i>Lomandra longifolia</i> |
| <i>Austrostipa pubescens</i> | <i>Entolasia marginata</i> | <i>Microlaena stipoides</i> |
| <i>Blechnum indicum</i> | <i>Ficinia nodosa</i> | <i>Oplismenus imbecillis</i> |
| <i>Centella asiatica</i> | <i>Gahnia clarkei</i> | <i>Themeda triandra</i> |
| <i>Commelina cyanea</i> | <i>Imperata cylindrica</i> | |
| <i>Dianella caerulea</i> | <i>Juncus usitatus</i> | |

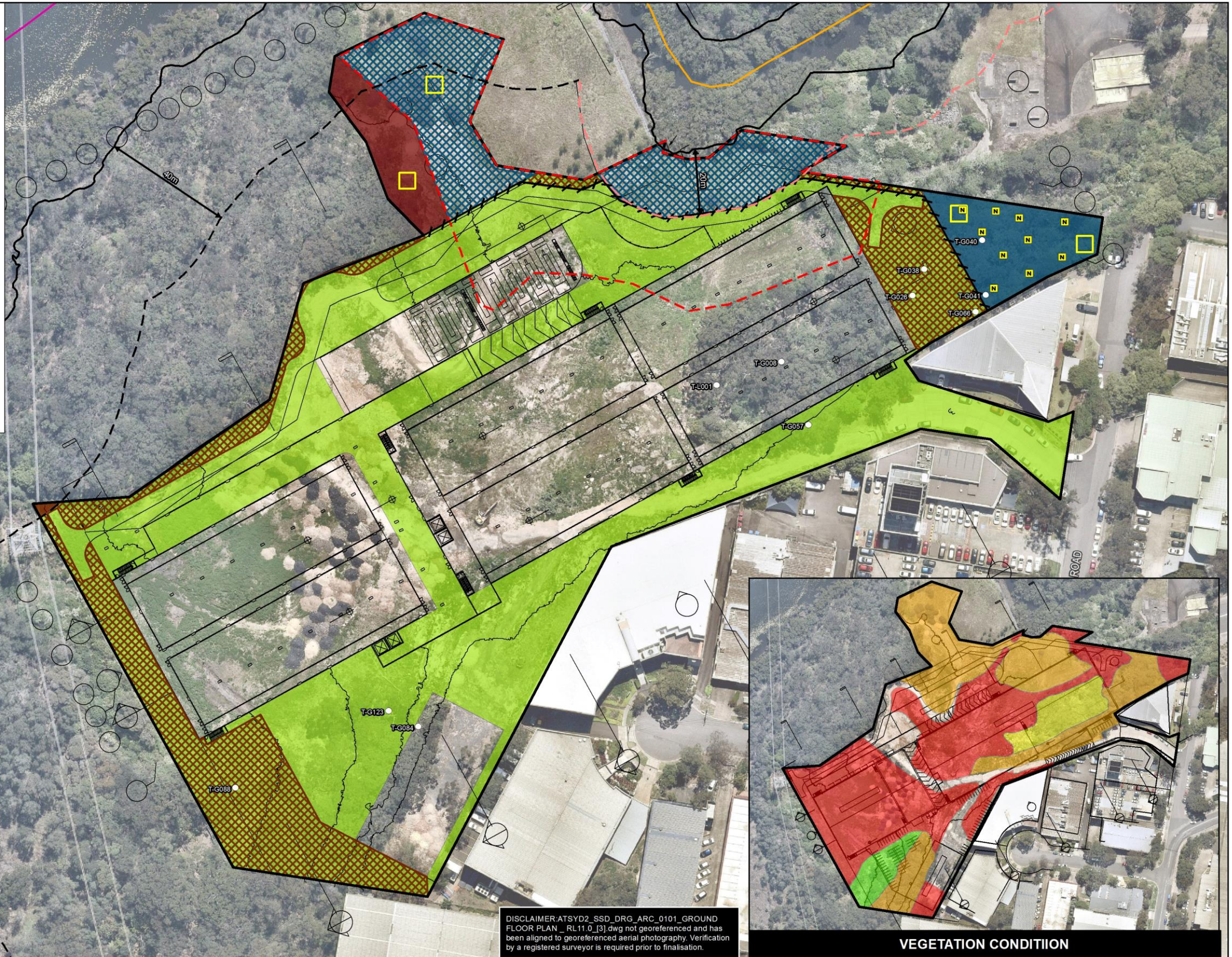

DISCLAIMER: ATSYD2_SSD_DRG_ARC_0101_GROUND FLOOR PLAN_RL11.0_[3].dwg not georeferenced and has been aligned to georeferenced aerial photography. Verification by a registered surveyor is required prior to finalisation.

Legend

| | | | |
|--|---|--|---|
| Study area (source: CAD) | Stream order (source: LPI) Second order Fifth order | Restoration Works Bush regeneration (0.12 ha) Smooth-barked Apple - Red Bloodwood Open Forest Fully structured revegetation (0.08 ha) Smooth-barked Apple - Red Bloodwood Open Forest Shrub & groundcover plantings only (0.28 ha) Swamp Oak Floodplain Forest Managed vegetation (0.43 ha) Asset protection zone | Vegetation Condition Good (<10% weeds) Fair (10 - 30% weeds) Poor (30 - 60% weeds) Very Poor (>60% weeds) |
| Contaminated lands | Riparian corridor 20m buffer 40m buffer | | |
| Permanent protection/sediment fencing (209m) | | | |
| Hollow-bearing tree | | | |
| Nest box (10) | | | |
| Monitoring quadrat (5x5m) | | | |
| Asset Protection Zone (APZ) | | | |

PROJECT & MXD REFERENCE
1 Sirius Road, Lane Cove West
18AWE02_VMP001

DATE & ISSUE NUMBER
18/12/2018
Issue 1

SCALE & COORDINATE SYSTEM
1:1,200 @A3
GDA 1994 MGA Zone 56

TITLE
Schedule 1 -Vegetation Management Works Plan

Document Path: N:\GIS STORAGE\N Drive\18AWE02_SiriusRd_LaneCoveWest\MXD\18AWE02_VMP001.mxd

Disclaimer: The mapping is indicative of available space and location of features which may prove critical in assessing the viability of the proposed works. Mapping has been produced on a map base with an inherent level of inaccuracy, the location of all mapped features are to be confirmed by a registered surveyor.

