

Reference: Schedule 2 – Part B

Project Approval Condition	Project Approval Description
B38	HERITAGE – MINIMISING IMPACTS The Applicant shall prepare detailed elevation and window plans for the Royal Hall of Industries in consultation with Heritage NSW and Council (or its delegate) demonstrating how the proposal will minimise heritage impacts to the greatest extent practicable. Evidence of endorsement by Heritage NSW must be submitted to the Secretary.

In Response to Condition B38 of Schedule 2 – Part B. The following Drawings SK.03.0020 and AT.75.0003 have been prepared by Populous and Urbis Heritage to demonstrate the proposed strategy for minimising heritage impacts to existing windows and doorways. The following principles will be adhered to for all existing windows and openings:

1. Existing Heritage Windows (Refer Drawing SK.03.0020)
 - Remove existing putty and glazing. Any original building glazing to be catalogued and stored onsite as part of Heritage management plan.
 - Each existing timber window sash, frame and sill will be assessed for degradation and decay. If there is significant damage, elements will need to be replaced to match existing.
 - For sashes and frames in good condition. Repaint to match current colour. Note; due to the presence of lead paint, windows will only be stripped where absolutely necessary for occupant safety.
 - Replace with new LowE glass to comply with JV3 specification. For all glazing below 1000mm high, safety glass to comply with AS1288 is required
 - Re-putty new glazing and reseal all windows as fixed panels.

2. Existing Doorways (Refer Drawing AT.75.0003)
 - The existing entrance doors are contemporary and are not significant. They will be removed and opening repaired and made good, ready for new door suite.
 - New hardwood framed arched doorways and fixed glass panels to be installed in Brickwork openings. New timber frames will be clear seal coated to delineate new works from the original painted heritage windows.
 - Patch and repair internal render to line of new Frame.

3. New modified openings (Refer Drawing AT.75.0003 – Details 1,4,15,16)
 - The RHI propose five (5) modifications to the existing brickwork fabric for new openings. These involve the partial removal of brickwork to expand existing window openings to create doorways.
 - For each opening, saw cut and remove existing brickwork as required for opening size. All existing brickwork and removed windows are to be cleaned, catalogued, and stored onsite, for reuse in the event of future patch and repairs, as part of Heritage management plan.
 - Apply 13mm render finish to inner face of cut brickwork to make good opening modifications
 - New hardwood framed doorways and fixed glass panels to be installed in new Brickwork opening. New timber frames will be clear seal coated to delineate new works from the original painted heritage windows.



Henry Coates

Architect
BOAQ Reg 5281

23rd July, 2021

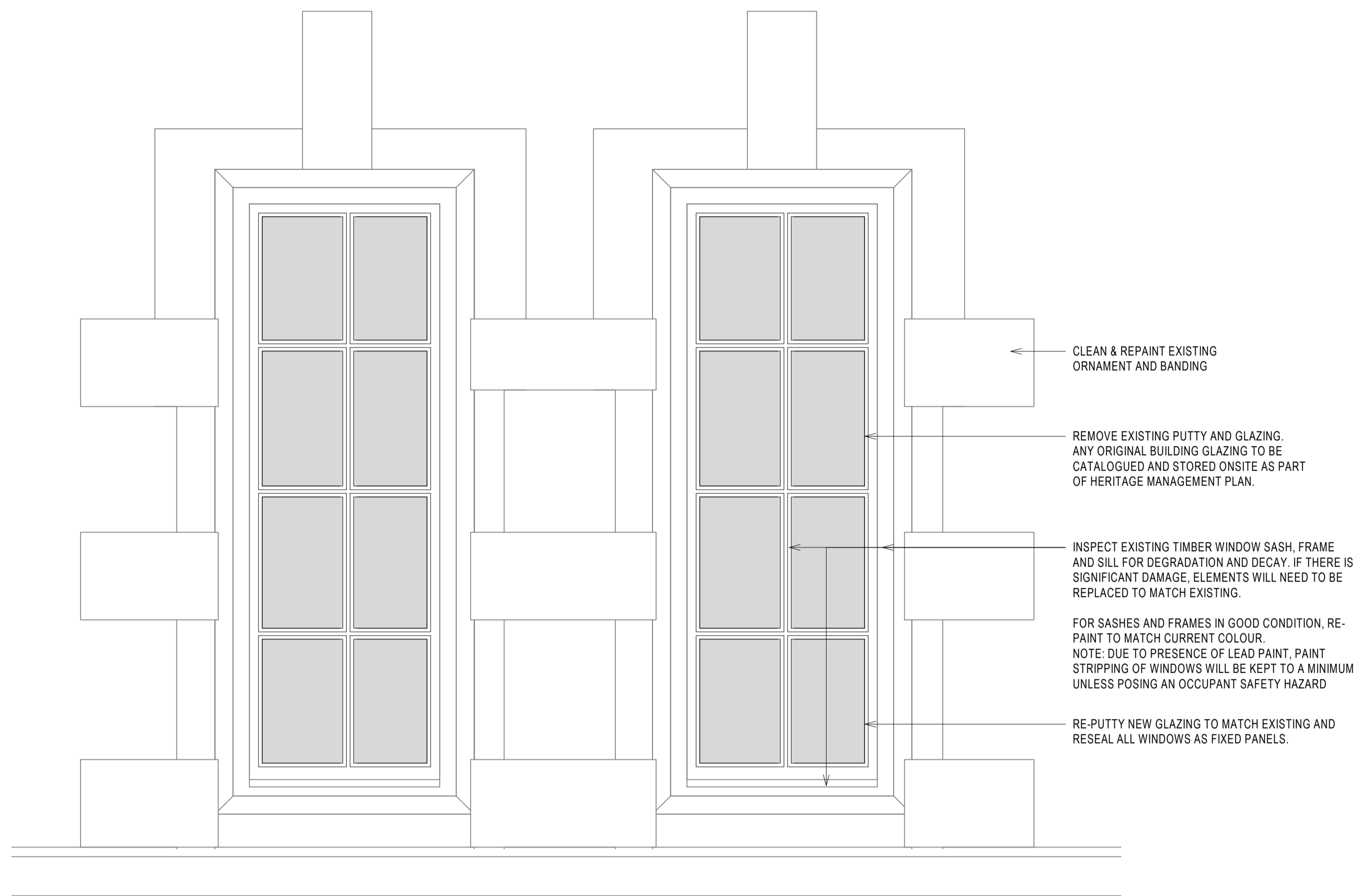

1 RHI TYPICAL GROUND FLOOR WINDOW
1:10

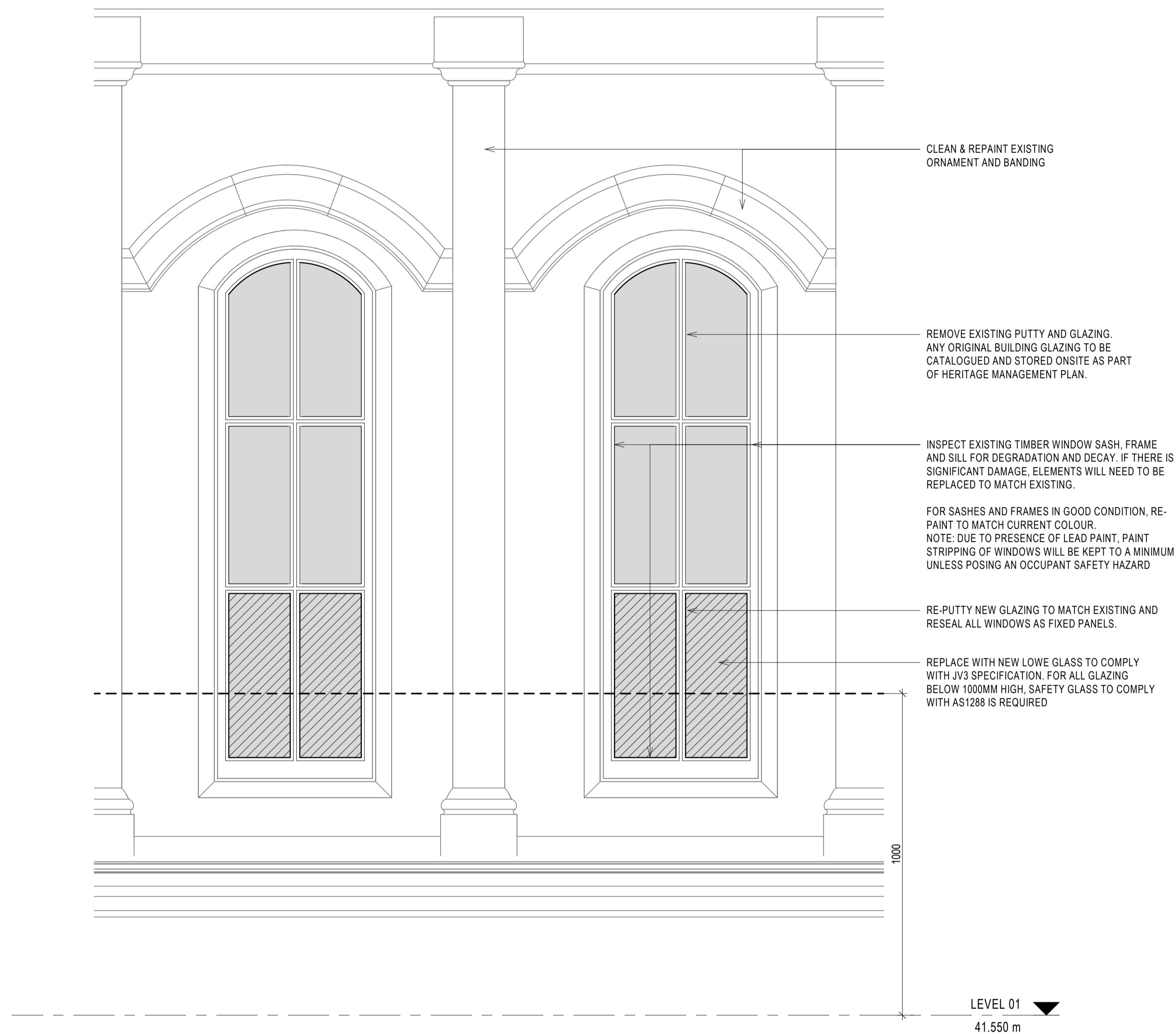

2 RHI TYPICAL LEVEL 01 WINDOW
1:10

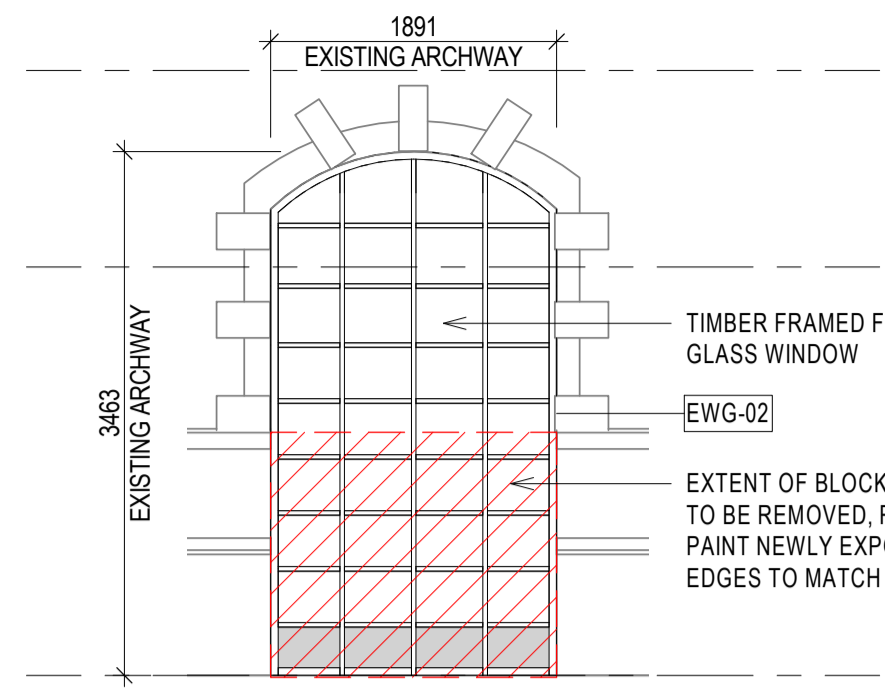

1 RHI NORTH ELEVATION - EWG-N0-G19
1:50

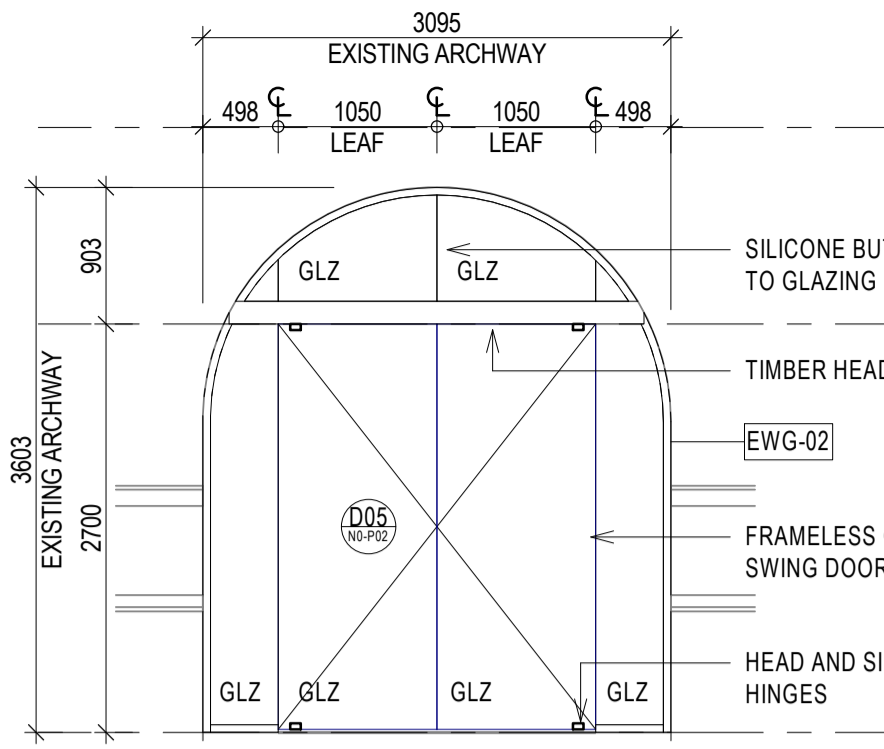

2 RHI NORTH ELEVATION - EWG-N0-P02
1:50

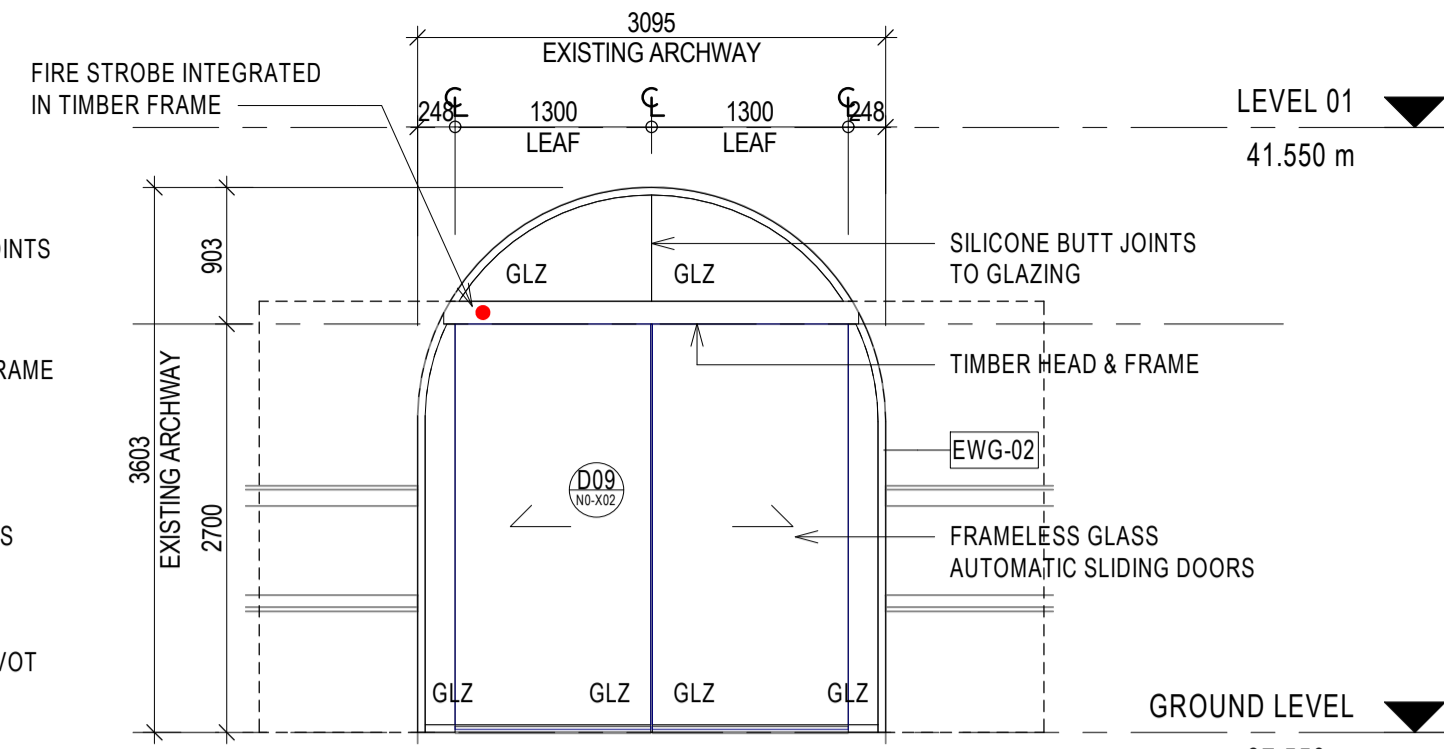

3 RHI NORTH ELEVATION - EWG-N0-X02
1:50

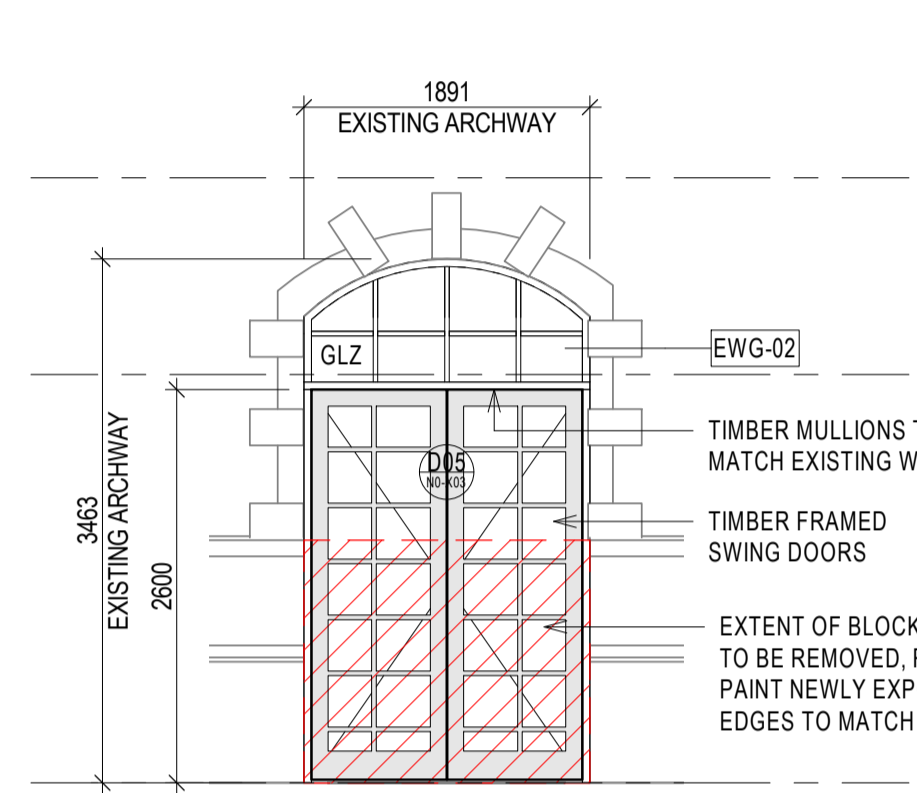
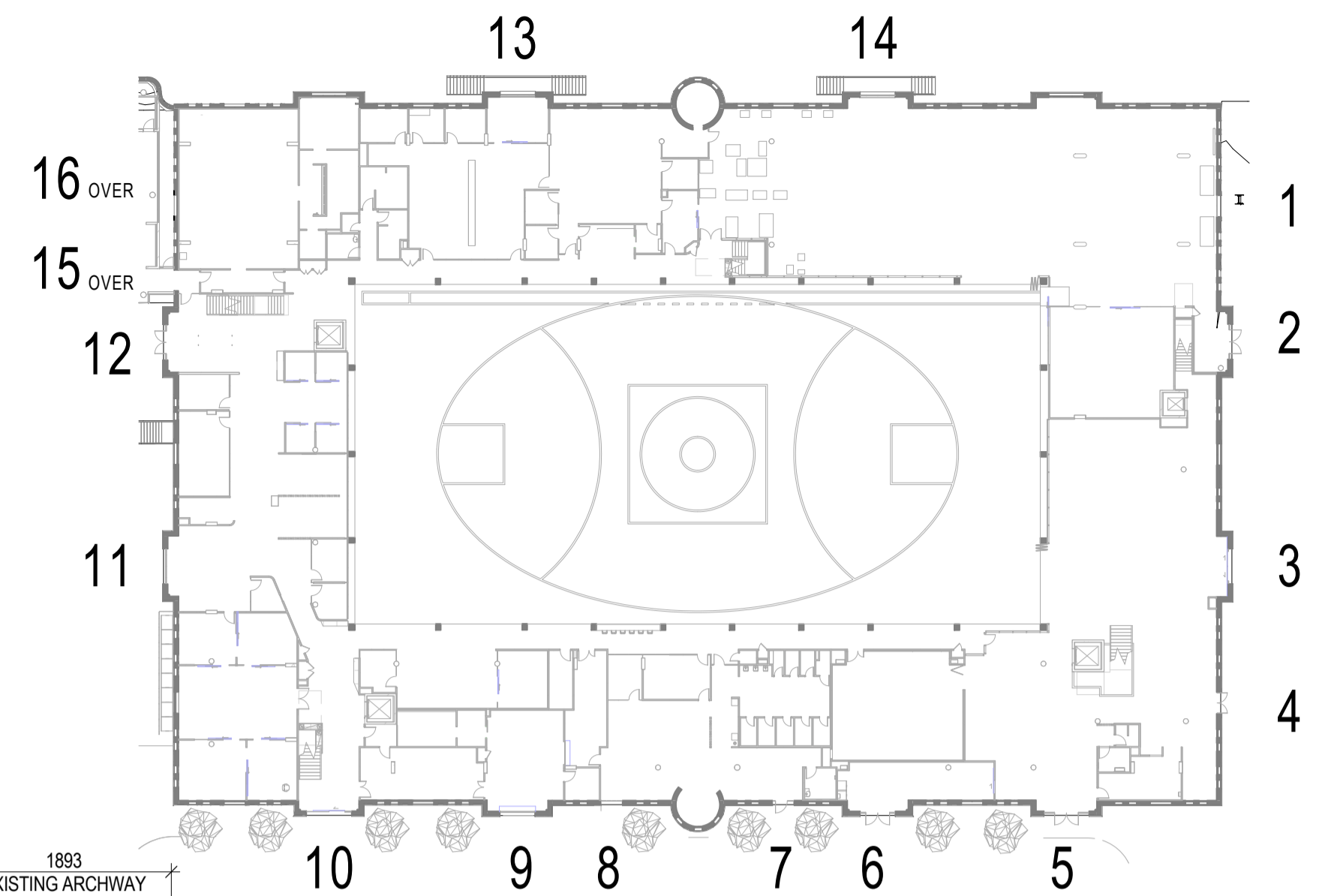

4 RHI NORTH ELEVATION - EWG-N0-X03
1:50

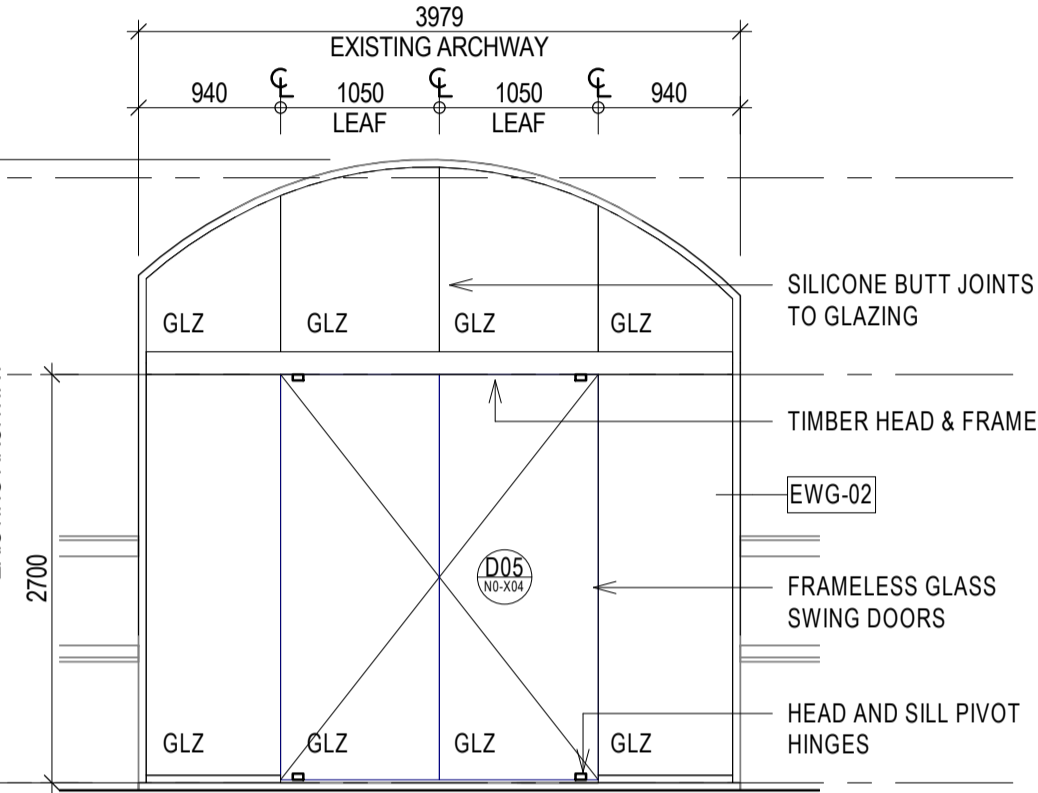

5 RHI EAST ELEVATION - EWG-N0-X04
1:50

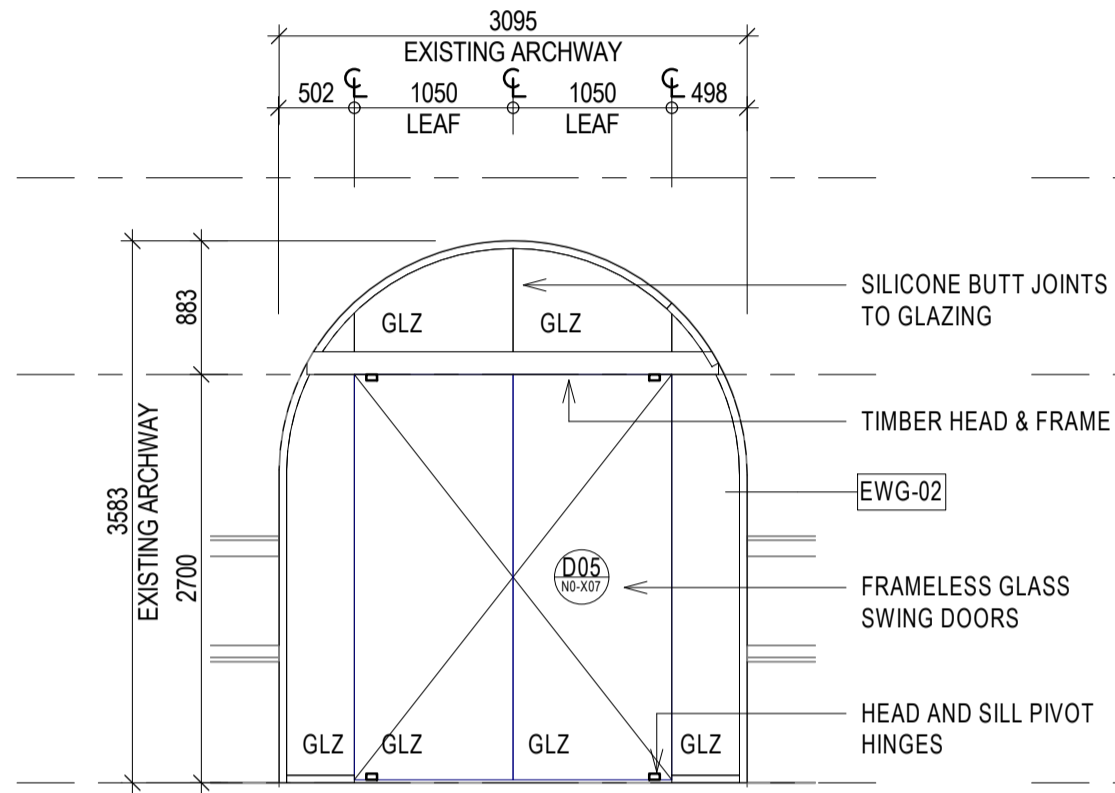

6 RHI EAST ELEVATION - EWG-N0-X07
1:50

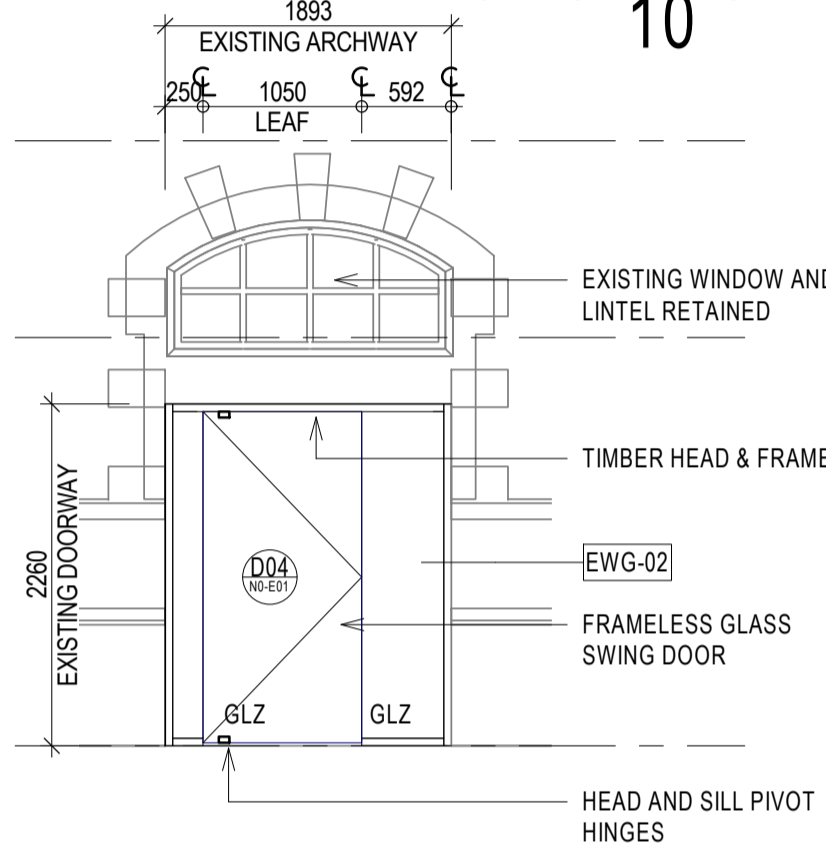

7 RHI EAST ELEVATION - EWG-N0-E01
1:50

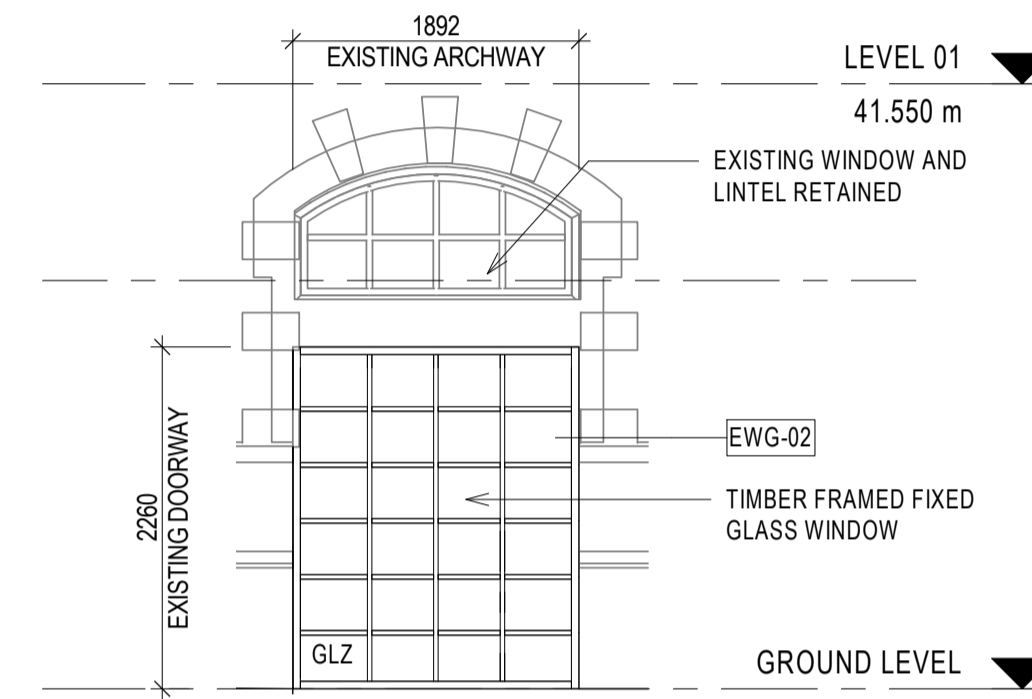

8 RHI EAST ELEVATION - EWG-N0-XXX
1:50

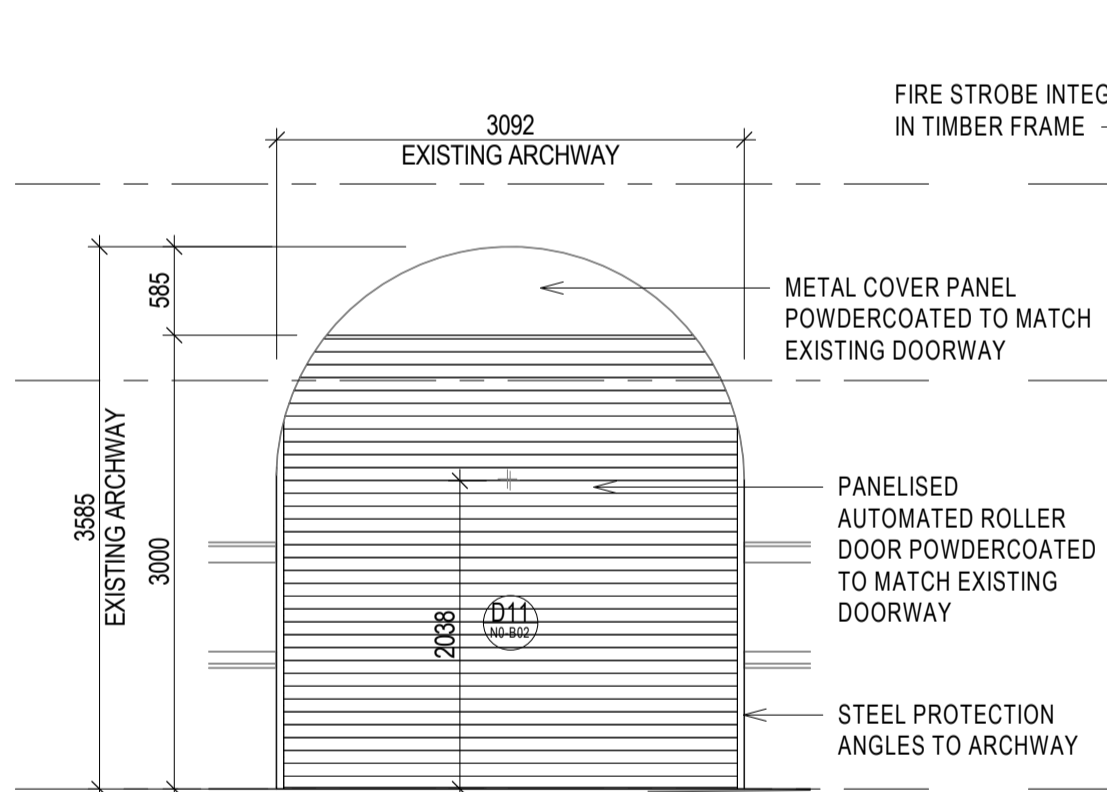

9 RHI EAST ELEVATION - EWG-N0-B02
1:50

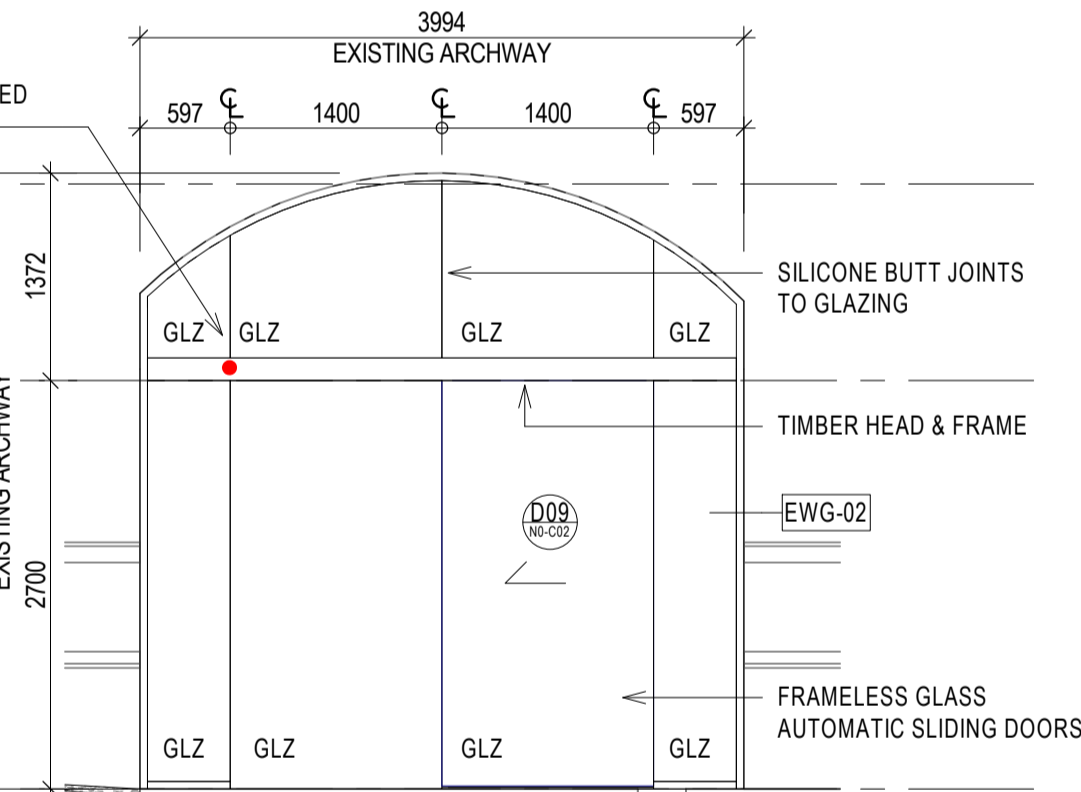

10 RHI EAST ELEVATION - EWG-N0-C02
1:50

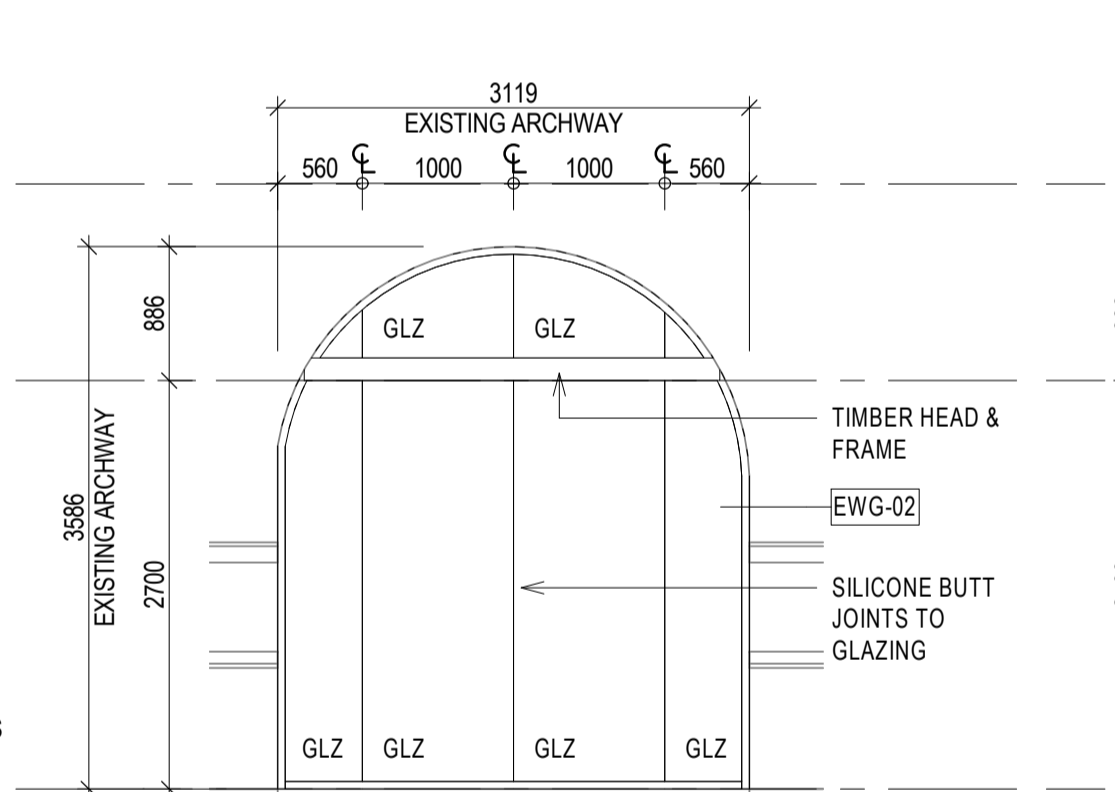

11 RHI SOUTH ELEVATION - EWG-N0-D21
1:50

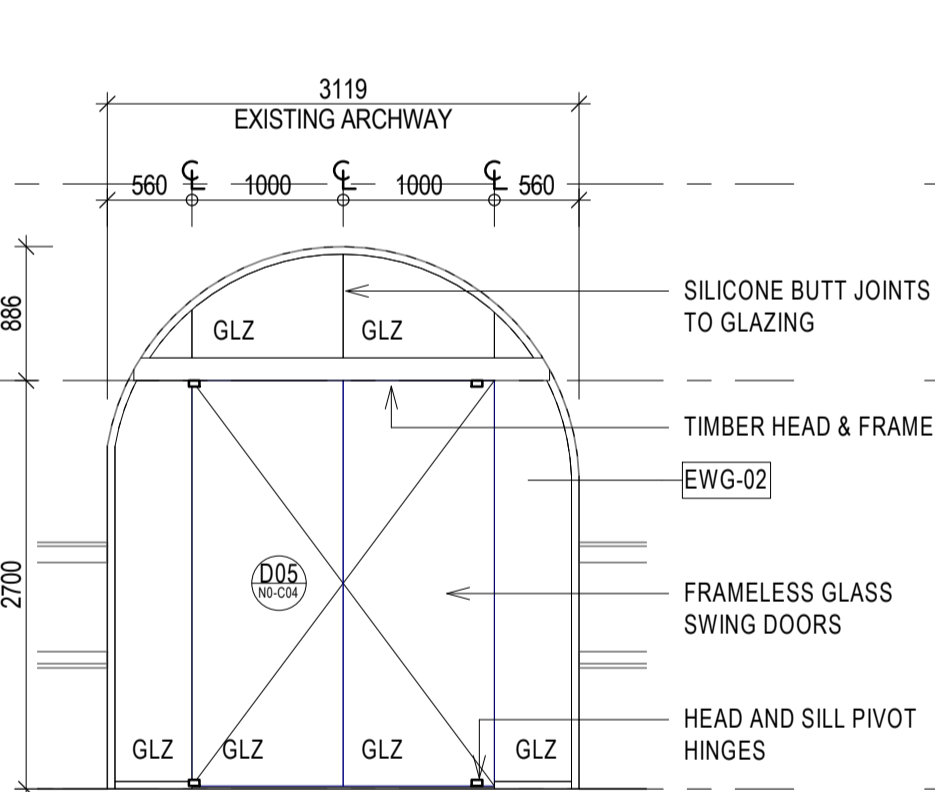

12 RHI SOUTH ELEVATION - EWG-N0-C04
1:50

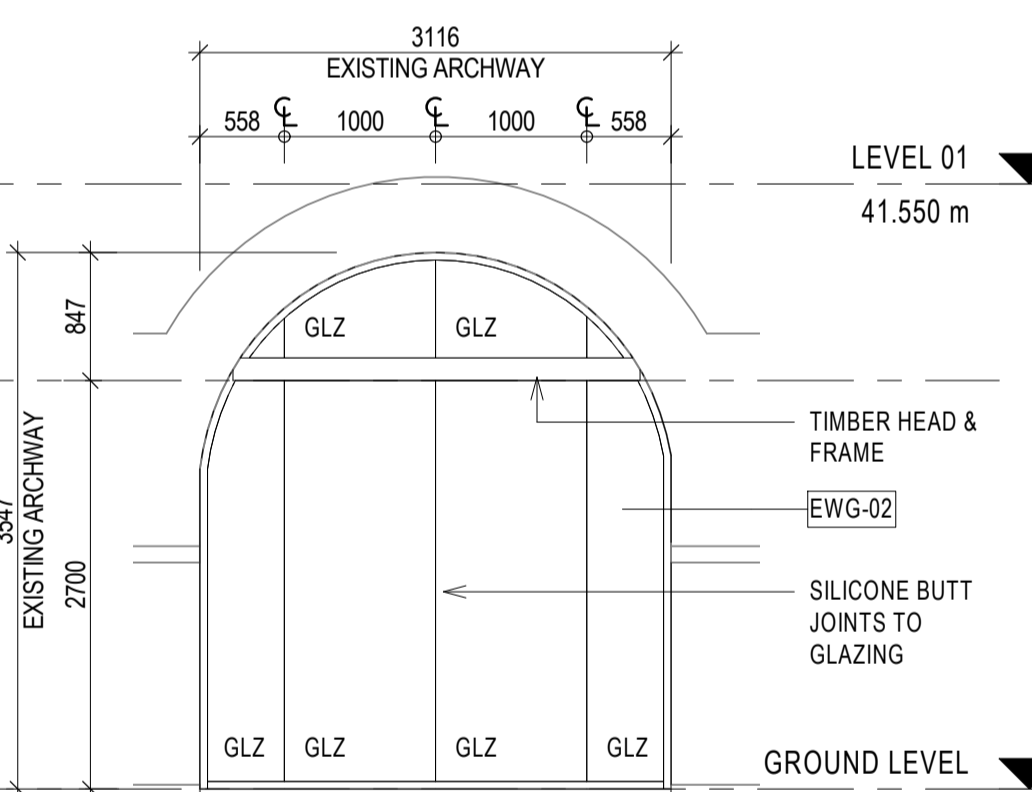

13 RHI WEST ELEVATION - N0-G04
1:50

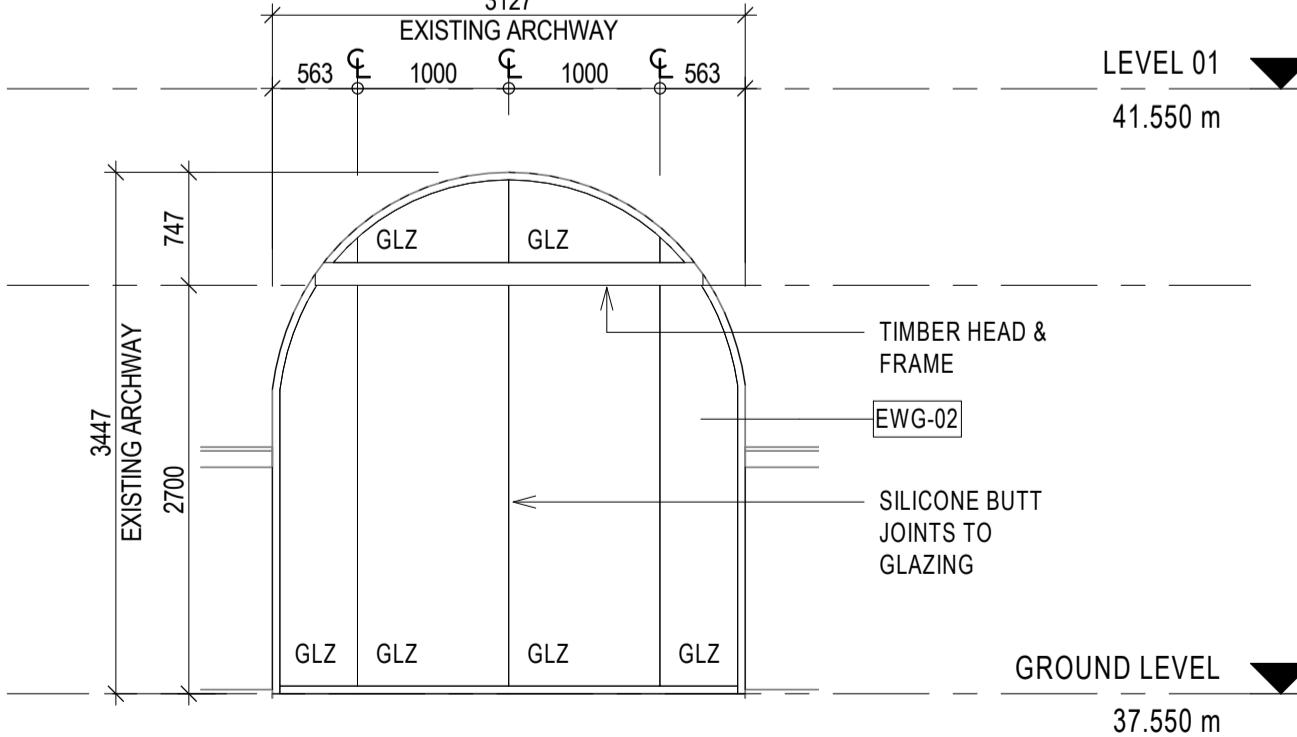

14 RHI WEST ELEVATION - EWG-N0-G19
1:50

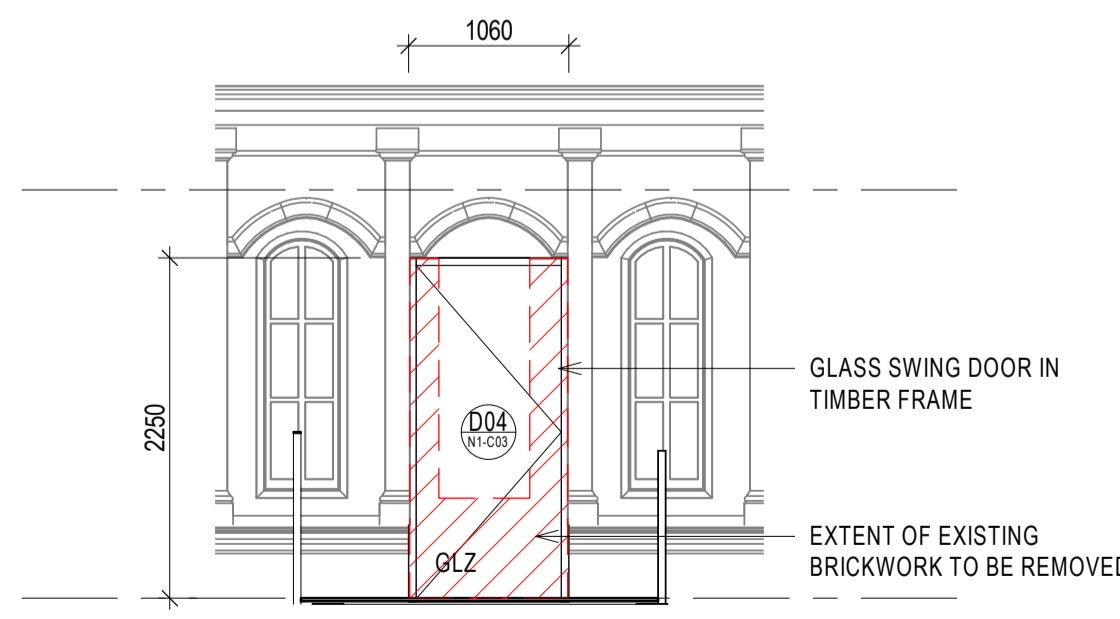

15 RHI SOUTH ELEVATION - EWG-N1-C03
1:50

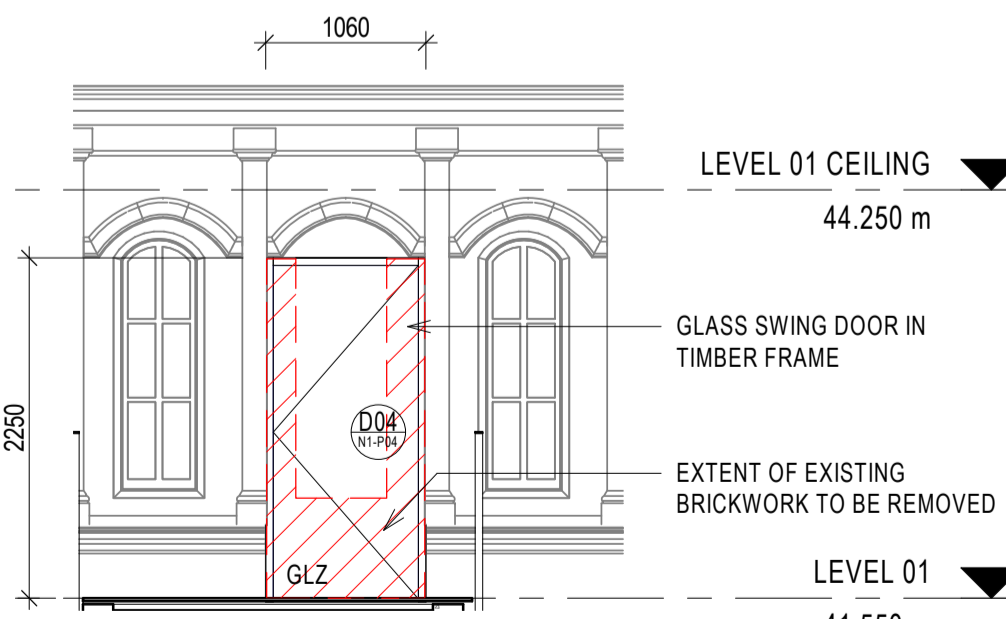

16 RHI SOUTH ELEVATION - EWG-N1-P04
1:50

NOTE: ALL NEW TIMBER FRAMES TO BE CLEAR SEALED ROSEWOOD TO DIFFERENTIATE NEW WORKS FROM ORIGINAL PAINTED JOINERY

- EXISTING DOORWAYS (REFER DRAWING AT 75.0003)
- THE EXISTING ENTRANCE DOORS ARE CONTEMPORARY AND ARE NOT SIGNIFICANT. THEY WILL BE REMOVED AND OPENING REPAIRED AND MADE GOOD, READY FOR NEW DOOR SUITE.
- NEW HARDWOOD FRAMED ARCHED DOORWAYS AND FIXED GLASS PANELS TO BE INSTALLED IN BRICKWORK OPENINGS. NEW TIMBER FRAMES WILL BE CLEAR SEAL COATED TO DELINEATE NEW WORKS FROM THE ORIGINAL PAINTED HERITAGE WINDOWS.
- PATCH AND REPAIR INTERNAL RENDER TO LINE OF NEW FRAME.
- NEW MODIFIED OPENINGS (REFER DRAWING AT 75.0003 - DETAILS 1.4.15.16)
- THE RHI PROPOSE FIVE (5) MODIFICATIONS TO THE EXISTING BRICKWORK FABRIC FOR NEW OPENINGS. THESE INVOLVE THE PARTIAL REMOVAL OF BRICKWORK TO EXPAND EXISTING WINDOW OPENINGS TO CREATE DOORWAYS.
- FOR EACH OPENING, SAW CUT AND REMOVE EXISTING BRICKWORK AS REQUIRED FOR OPENING SIZE. ALL EXISTING BRICKWORK AND REMOVED WINDOWS ARE TO BE CLEANED, CATALOGUED, AND STORED ONSITE, FOR REUSE IN THE EVENT OF FUTURE PATCH AND REPAIRS, AS PART OF HERITAGE MANAGEMENT PLAN.
- APPLY 13MM RENDER FINISH TO INNER FACE OF CUT BRICKWORK TO MAKE GOOD OPENING MODIFICATIONS
- NEW HARDWOOD FRAMED DOORWAYS AND FIXED GLASS PANELS TO BE INSTALLED IN NEW BRICKWORK OPENING. NEW TIMBER FRAMES WILL BE CLEAR SEAL COATED TO DELINEATE NEW WORKS FROM THE ORIGINAL PAINTED HERITAGE WINDOWS.

FOR CONSTRUCTION CERTIFICATE

FOR INFORMATION ONLY - NOT FOR CONSTRUCTION