

2 RHI NORTH ELEVATION - EWG-N0-P02
1:50

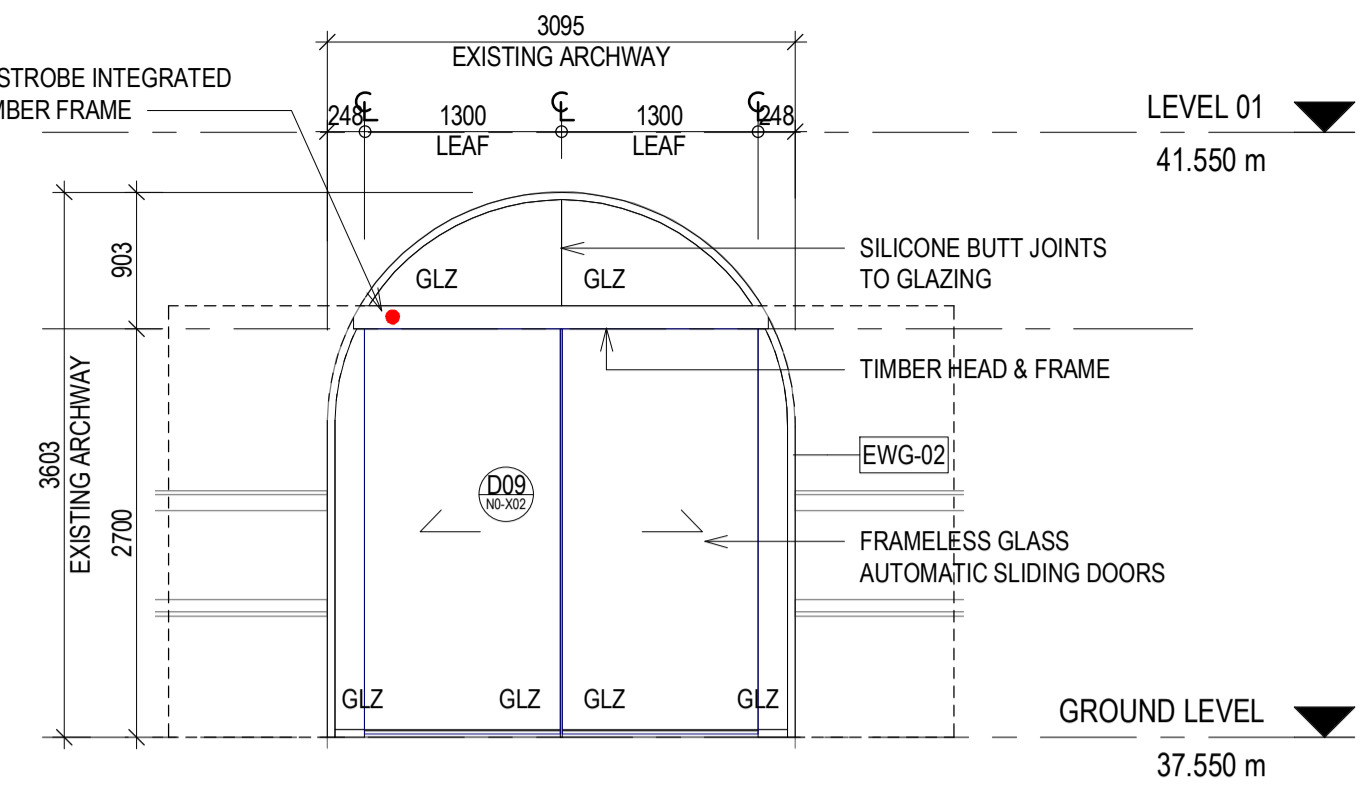

3 RHI NORTH ELEVATION - EWG-N0-X02
1:50

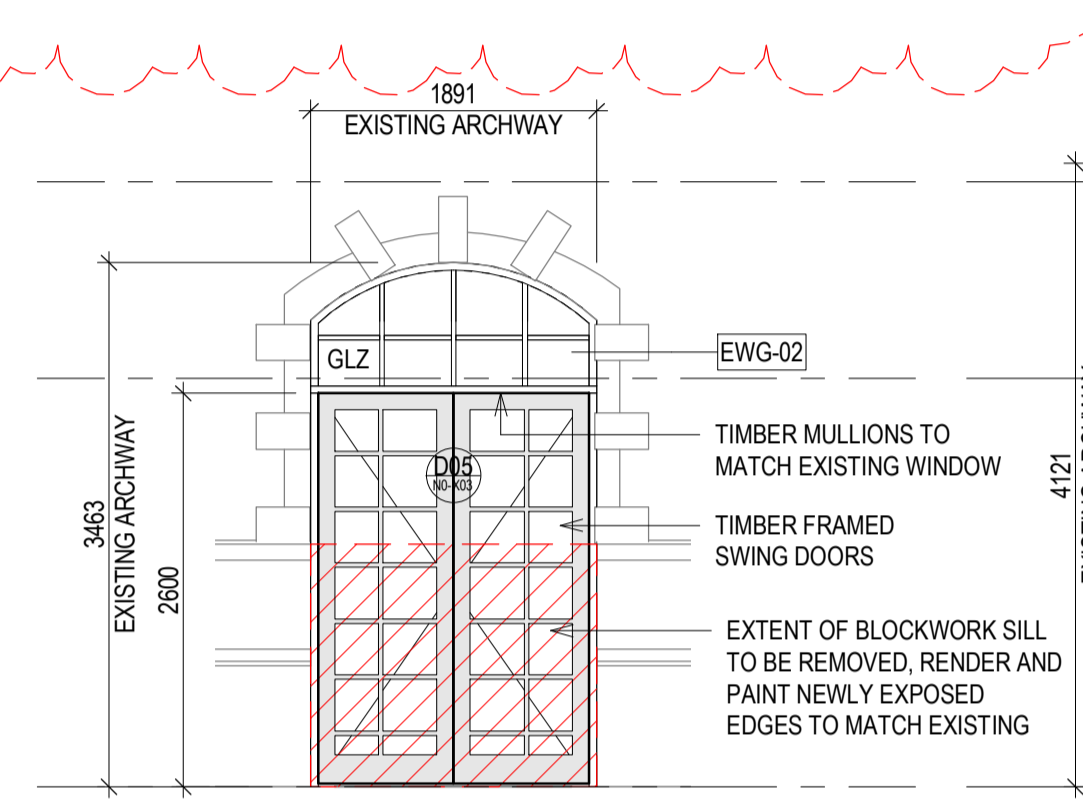
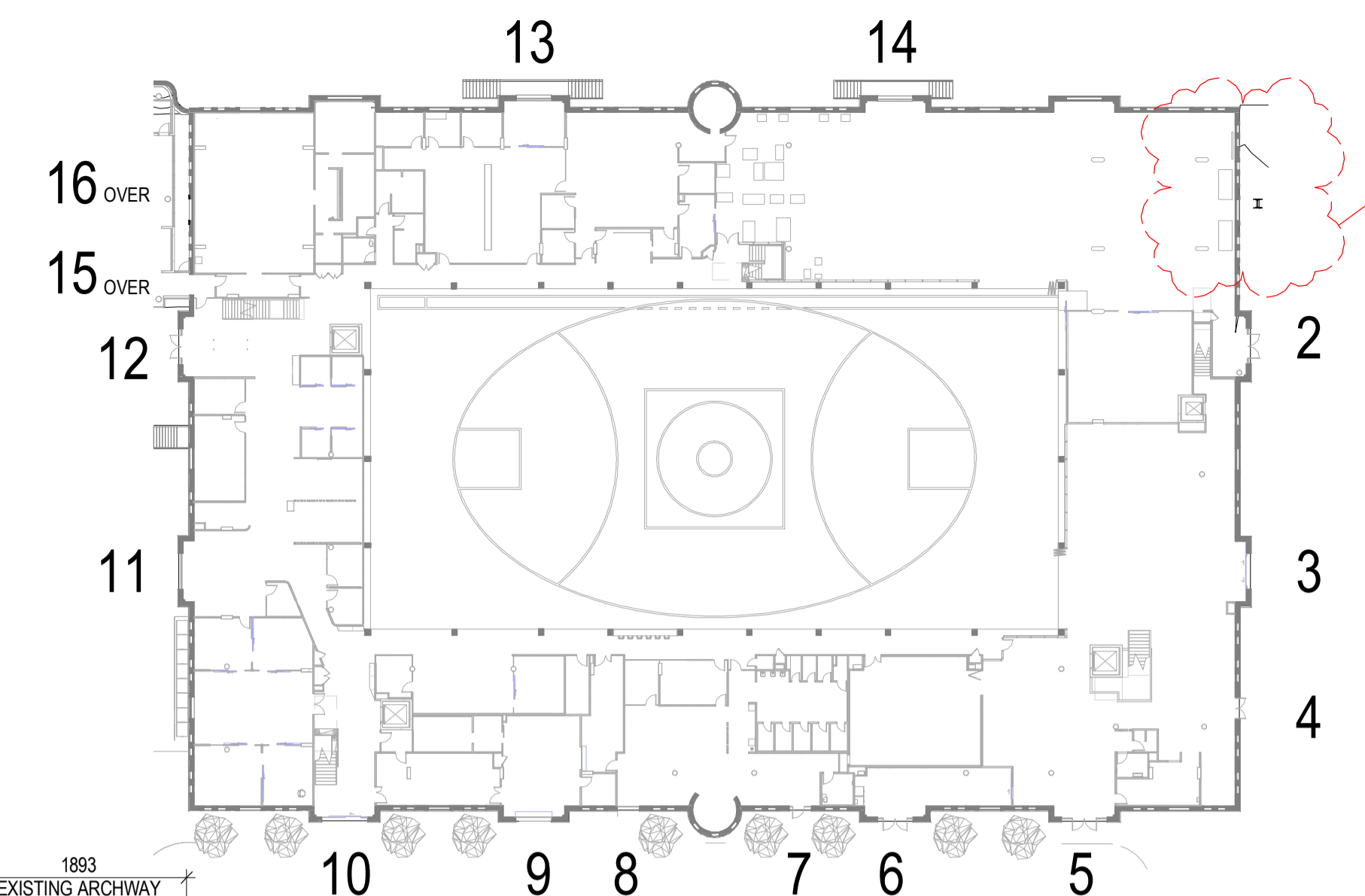

4 RHI NORTH ELEVATION - EWG-N0-X03
1:50

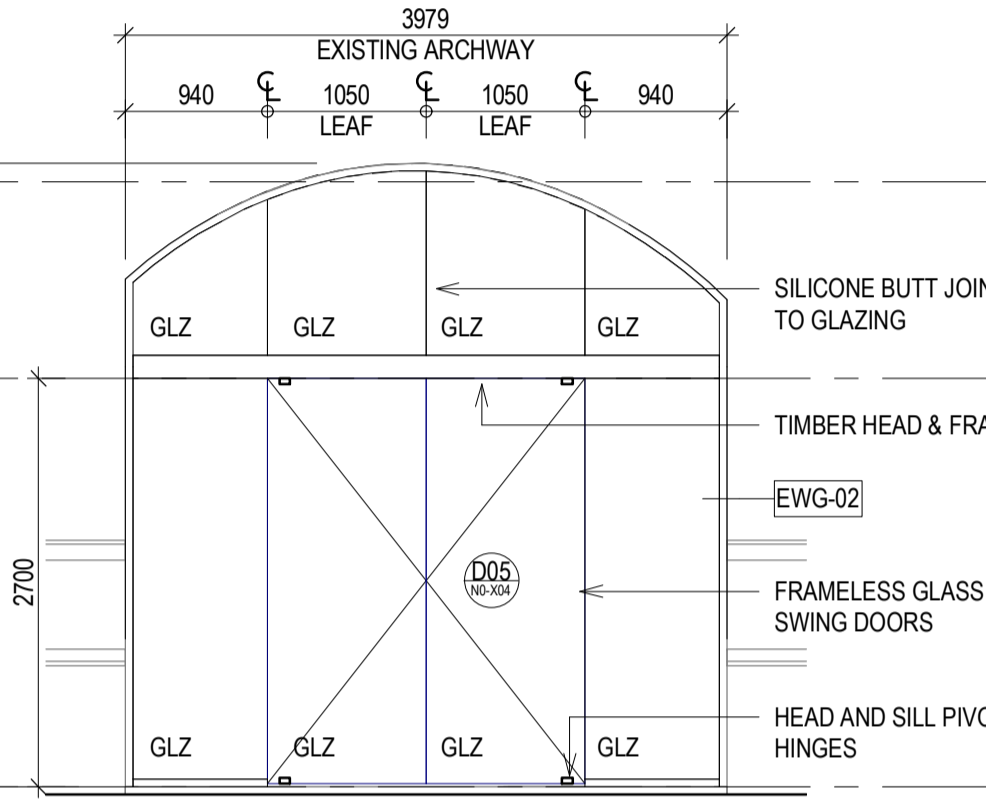

5 RHI EAST ELEVATION - EWG-N0-X04
1:50

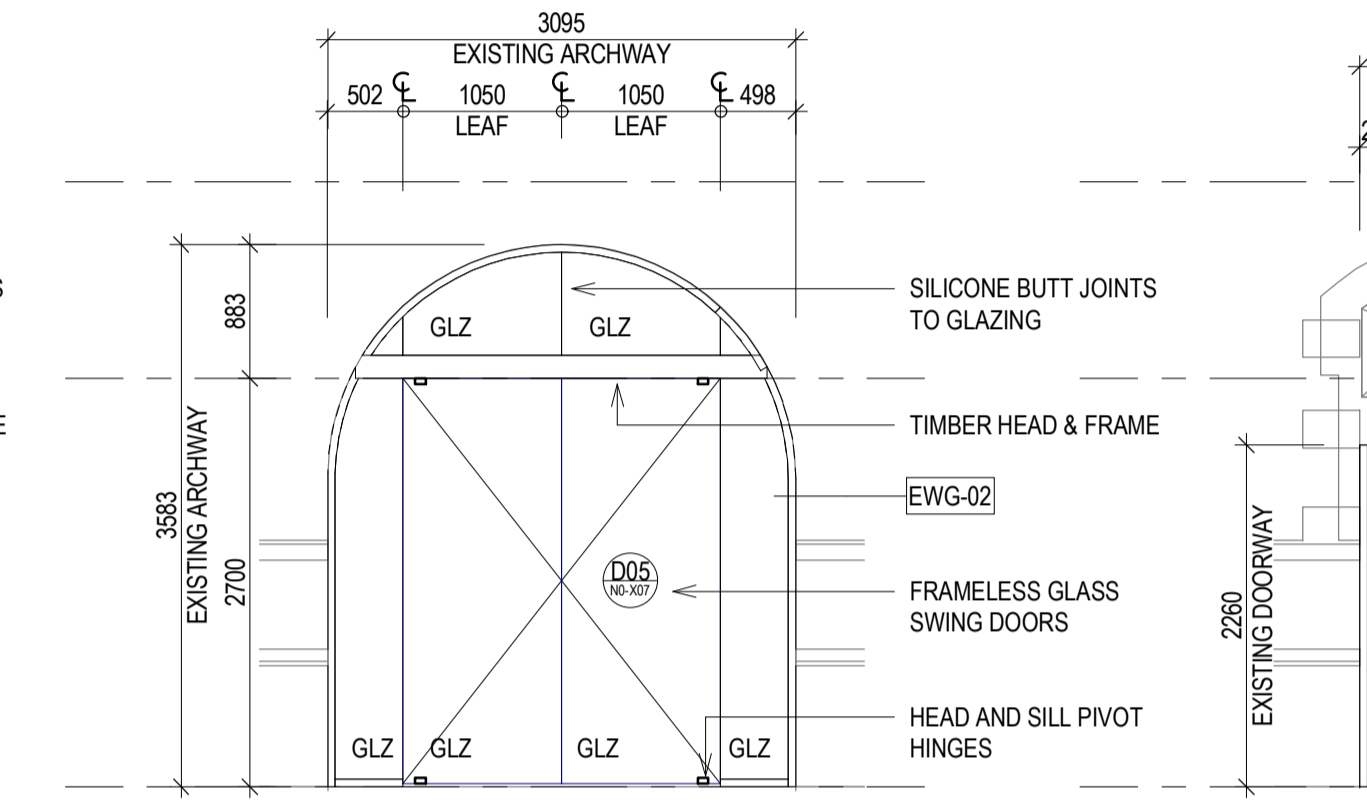

6 RHI EAST ELEVATION - EWG-N0-X07
1:50

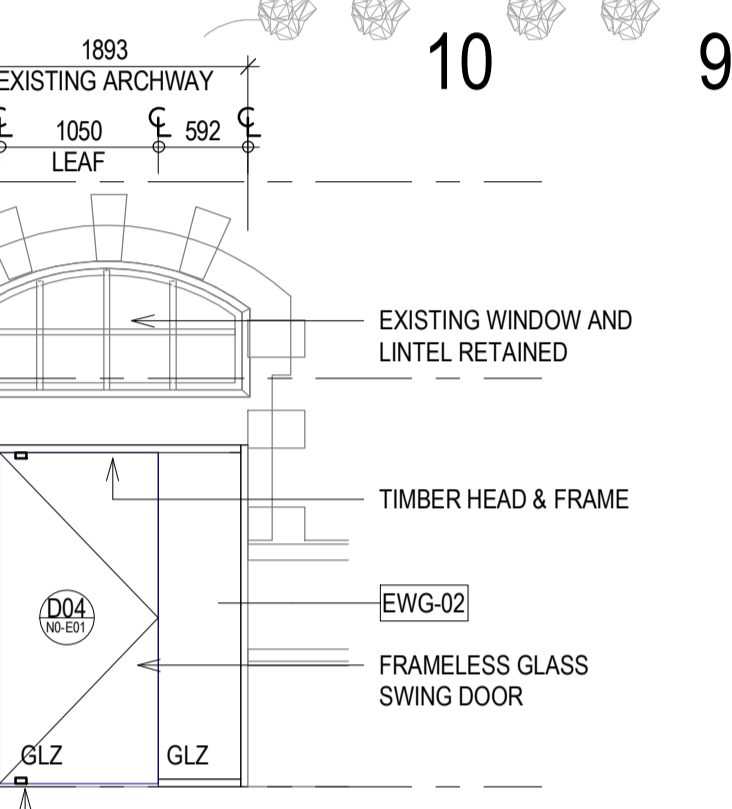

7 RHI EAST ELEVATION - EWG-N0-E01
1:50

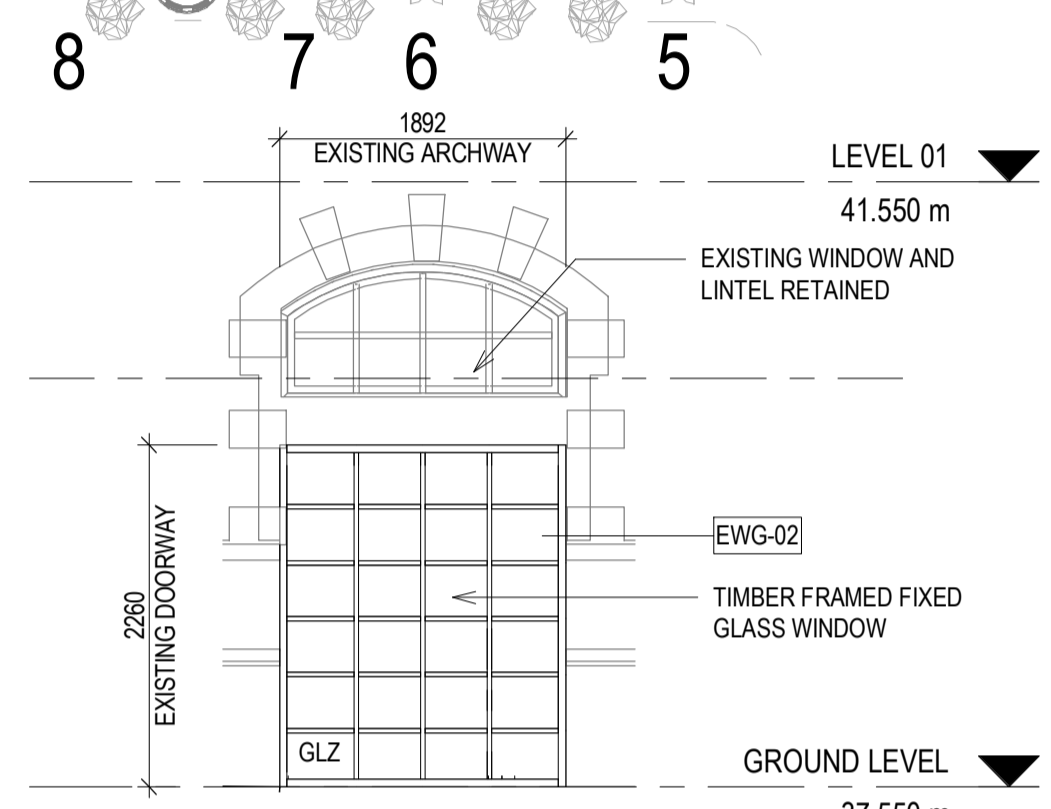

8 RHI EAST ELEVATION - EWG-N0-XXX
1:50

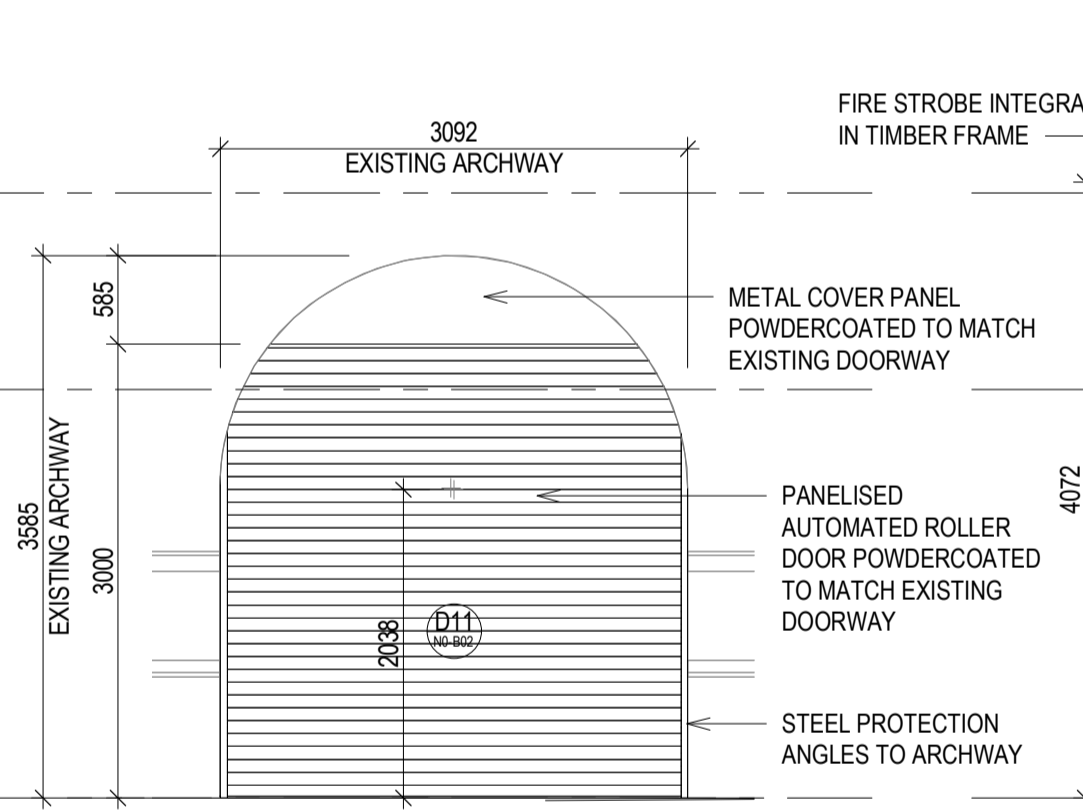

9 RHI EAST ELEVATION - EWG-N0-B02
1:50

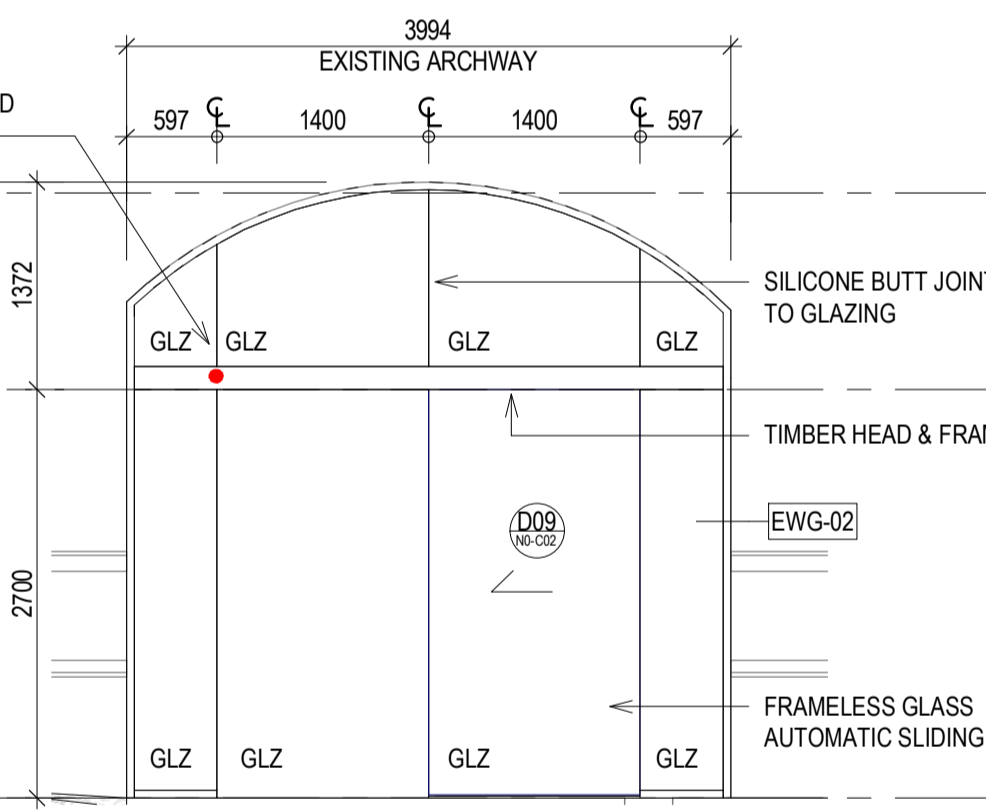

10 RHI EAST ELEVATION - EWG-N0-C02
1:50

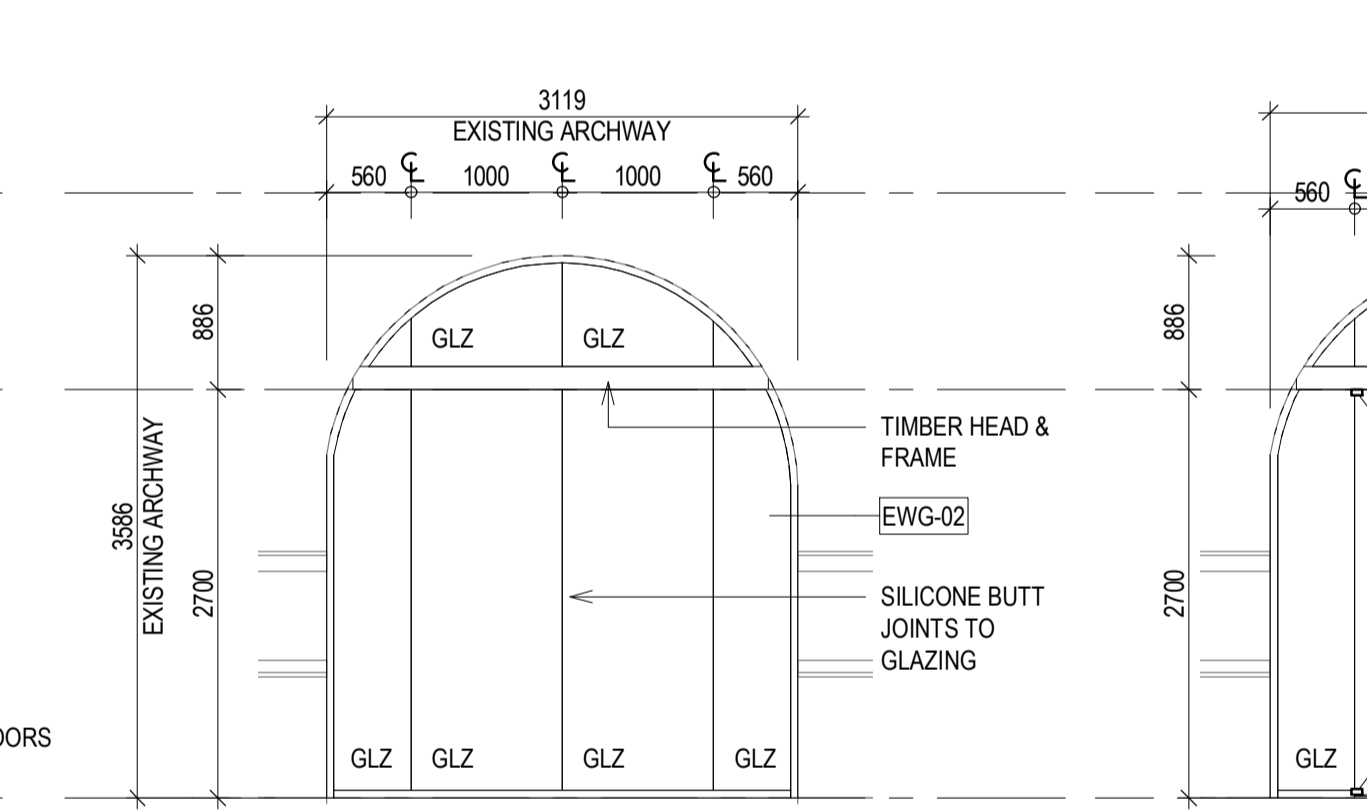

11 RHI SOUTH ELEVATION - EWG-N0-D21
1:50

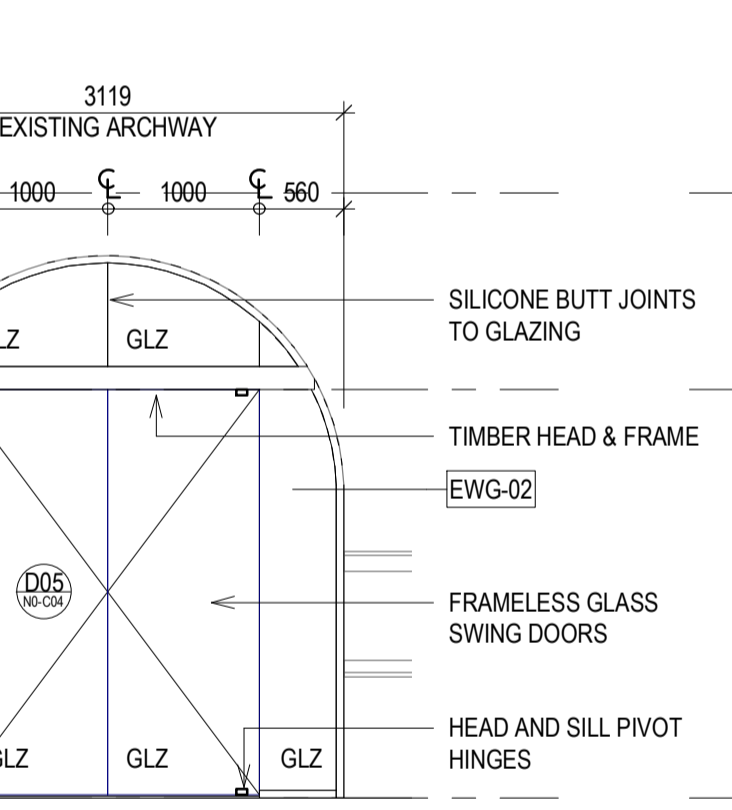

12 RHI SOUTH ELEVATION - EWG-N0-C04
1:50

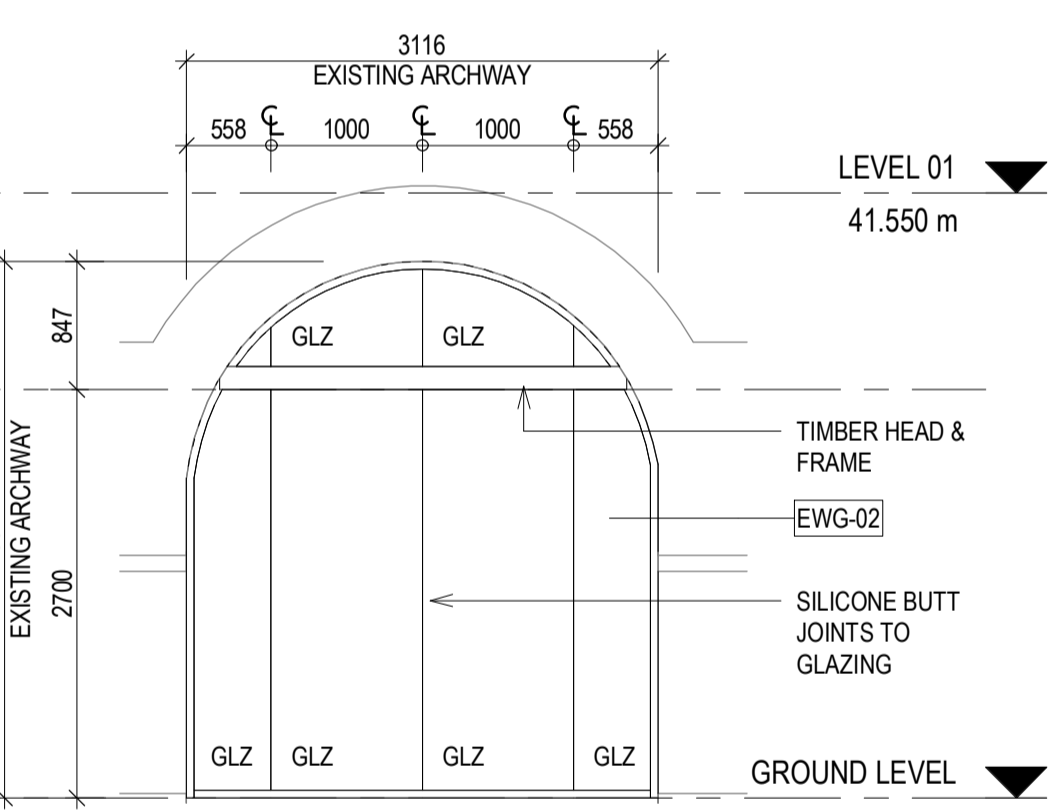

13 RHI WEST ELEVATION - N0-G04
1:50

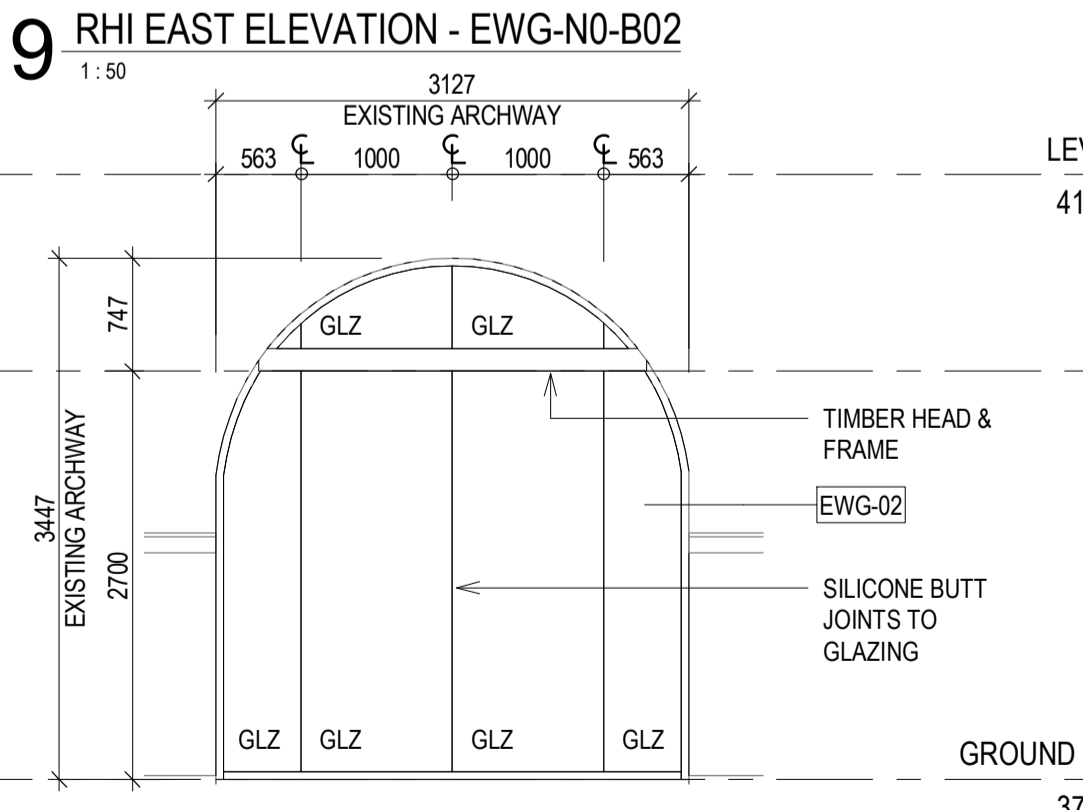

14 RHI WEST ELEVATION - EWG-N0-G19
1:50

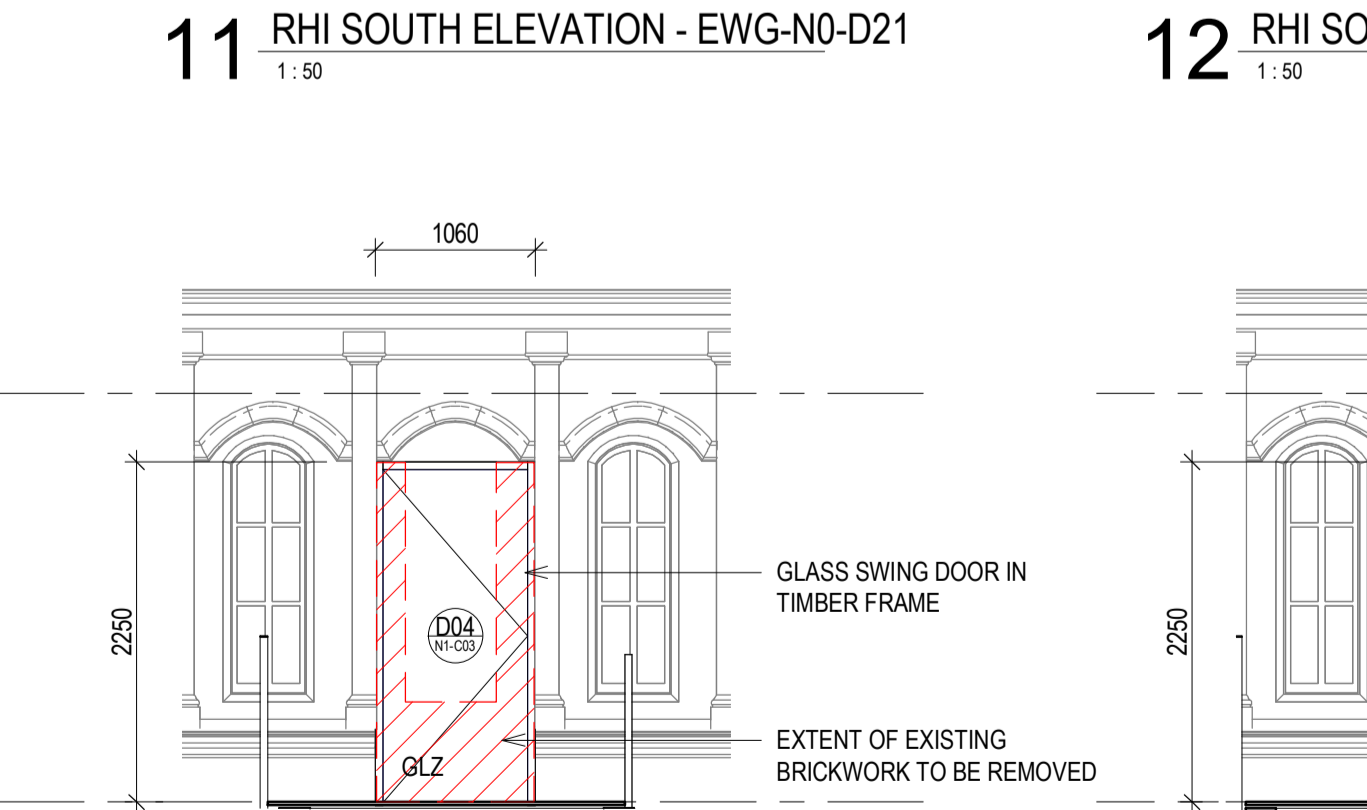

15 RHI SOUTH ELEVATION - EWG-N1-C03
1:50

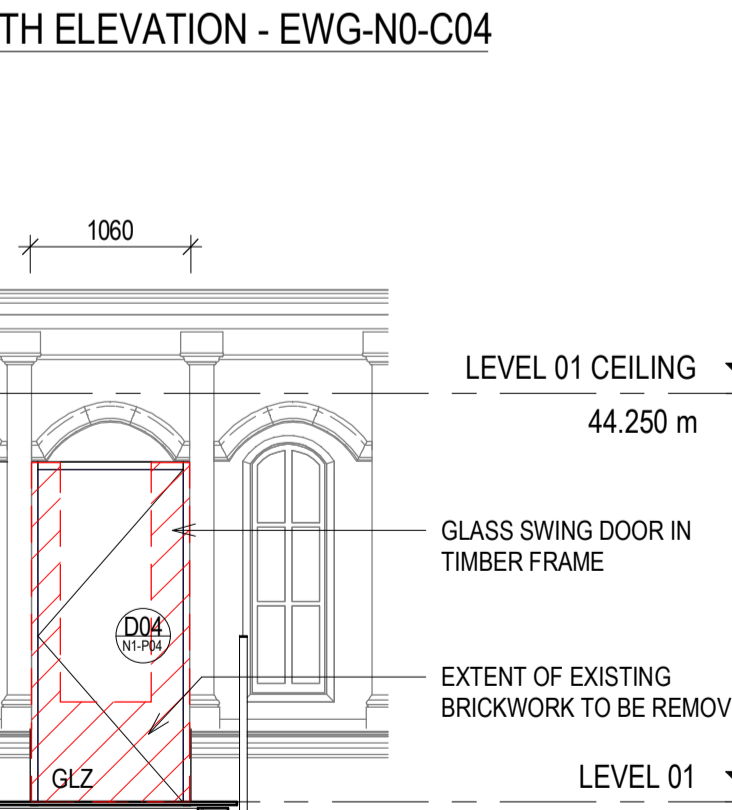

16 RHI SOUTH ELEVATION - EWG-N1-P04
1:50

NOTE: ALL NEW TIMBER FRAMES TO BE CLEAR SEALED ROSEWOOD TO DIFFERENTIATE NEW WORKS FROM ORIGINAL PAINTED JOINERY

- EXISTING DOORWAYS (REFER DRAWING AT 75.0003)
- THE EXISTING ENTRANCE DOORS ARE CONTEMPORARY AND ARE NOT SIGNIFICANT. THEY WILL BE REMOVED AND OPENING REPAIRED AND MADE GOOD, READY FOR NEW DOOR SUITE.
- NEW HARDWOOD FRAMED ARCH DOORWAYS AND FIXED GLASS PANELS TO BE INSTALLED IN BRICKWORK OPENINGS. NEW TIMBER FRAMES WILL BE CLEAR SEAL COATED TO DELINEATE NEW WORKS FROM THE ORIGINAL PAINTED HERITAGE WINDOWS.
- PATCH AND REPAIR INTERNAL RENDER TO LINE OF NEW FRAME.
- NEW MODIFIED OPENINGS (REFER DRAWING AT 75.0003 - DETAILS 1.4.15.16)
- THE RHI PROPOSE FIVE (5) MODIFICATIONS TO THE EXISTING BRICKWORK FABRIC FOR NEW OPENINGS. THESE INVOLVE THE PARTIAL REMOVAL OF BRICKWORK TO EXPAND EXISTING WINDOW OPENINGS TO CREATE DOORWAYS.
- FOR EACH OPENING, SAW CUT AND REMOVE EXISTING BRICKWORK AS REQUIRED FOR OPENING SIZE. ALL EXISTING BRICKWORK AND REMOVED WINDOWS ARE TO BE CLEANED, CATALOGUED, AND STORED ONSITE, FOR REUSE IN THE EVENT OF FUTURE PATCH AND REPAIRS, AS PART OF HERITAGE MANAGEMENT PLAN.
- APPLY 13MM RENDER FINISH TO INNER FACE OF CUT BRICKWORK TO MAKE GOOD OPENING MODIFICATIONS
- NEW HARDWOOD FRAMED DOORWAYS AND FIXED GLASS PANELS TO BE INSTALLED IN NEW BRICKWORK OPENING. NEW TIMBER FRAMES WILL BE CLEAR SEAL COATED TO DELINEATE NEW WORKS FROM THE ORIGINAL PAINTED HERITAGE WINDOWS.

FOR CONSTRUCTION CERTIFICATE

FOR INFORMATION ONLY - NOT FOR CONSTRUCTION