

Issue	Description	Dwn	Appl	Date
0	ISSUE			20/10/2018

ARM
 ARCHITECTURE
 LEVEL 11/522 RINDERS LANE MELBOURNE VICTORIA 3000 AUS
 T/ 03 8613 1888 F/ 03 8613 1889
 mail@armarchitecture.com.au
 ABN 22 476 942 350
 www.armarchitecture.com.au

LEGEND - SCOPE
 THIS LEGEND APPLIES TO ALL NEW CONSTRUCTION PHASE DRAWINGS. DOES NOT APPLY TO EXISTING CONDITIONS.
 AREA SHOWN IN GREY WASH DEPICTS SCOPE OF NO NEW WORKS
 AREA SHOWN IN WHITE WASH DEPICTS SCOPE OF NEW WORKS
 AREA SURROUNDED BY GREEN DASHED LINES DEPICTS TENDER OPTION

SOHT GENERAL NOTES
 1. ALL DIMENSIONS AND SIZES ARE IN MILLIMETRES.
 2. DO NOT SCALE DRAWINGS. USE FIGURED DIMENSIONS ONLY.
 3. INFORMATION INDICATED IN THIS DOCUMENT MAY BE CRUCIAL TO THE SAFE AND PROPER FUNCTIONING OF THE SYDNEY OPERA HOUSE. DO NOT ALTER ANY ASPECT WITHOUT WRITTEN PERMISSION OF THE SYDNEY OPERA HOUSE TRUST.
 4. ALL NEW WORKS MUST COMPLY WITH THE SYDNEY OPERA HOUSE BUILDING SERVICES STANDARD SPECIFICATION (BSSS) AND RELEVANT AUSTRALIAN STANDARDS. NEW WORKS MUST ALSO COMPLY WITH THE REQUIREMENTS OF THE BUILDING CODES OF AUSTRALIA.

SOHT COPYRIGHT
 THIS DRAWING AND DESIGN ARE SUBJECT TO COPYRIGHT AND SHALL NOT BE COPIED IN ANY FORM WITH THE WRITTEN PERMISSION OF THE SYDNEY OPERA HOUSE TRUST

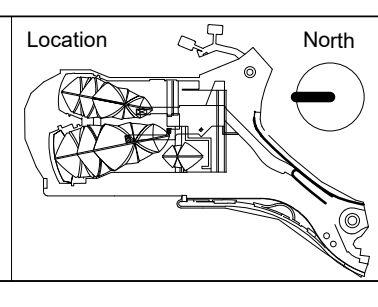

Status		Development Application Issue	
Dwn	JJF	Date	2/10/2018
Contract	BDM-168	Scale	1:500 @ B1

Project		Title	
BUILDING RENEWAL PROJECT - CONCERT HALL		LOCATION PLAN	

Sydney Opera House Trust
 GPO Box 4274 Sydney NSW Australia 2001
 Phone: +61 2 9256 7541
 email: info@sydneyoperahouse.com

© Sydney Opera House Trust



Location	CHVA	Drawing No:	49-BR-ARM01	Sheet:	DA0100	Rev:	D B1
----------	------	-------------	-------------	--------	--------	------	------



DA0301 INTERNAL MATERIALS & FINISHES SCHEDULE





0999 Sydney Opera House Concert Hall





PREPARED BY: AW & PRB



<i>ISSUE</i>	<i>REVISION</i>	<i>DATE</i>
DA ISSUE	A	27/10/17
DA ISSUE	B	26/04/18
DA ISSUE	C	21/09/18
DA ISSUE	D	5/10/18



Ref. Code	General Description	Detailed / Proprietary Description	Indicative Location	Rev
INTERIOR WORKS				
F. FLOOR & FLOOR FINISHES				
FAH	FLOOR ACCESS HATCH			
FAH-01	Floor Access Hatch Automated	Automated hatch door. Acoustically rated to maintain Winch Room attenuation. It requires removable handrail	Winch Room	
FAH-02	Floor Access Hatch Automated	Automated hatch door. Constructed to maintain Tech Zone floor load rating. Hatch door in raised position forms barrier. Upper 300 telescopes out of hatch door support. It required folding rails	Tech Zones	
FAW	ACCESS WALKWAY			
FAW-01	Access Walkway - steel grated	Webforge Grid Grating Flooring Grating Pattern: refer to Engineers Drawings Grating Finish: standard galvanised	Tech Zones Catwalks Ramps	
FAW-02	Access Walkway - steel grated	as per FAW-01 but connected to & matching existing .	Ramp to Plantroom	
FAW-02b	Access Walkway - associated stair	Webforge grating metal stair - spiral. Stair treads: steel grating Nosing: nosing type to AS code standard, bolt fixed to steel stringer. Grating finish: standard galvanised	Plantroom & Canon Port Gallery	
FBA	FLOOR BATTEN			
FBA-01	Floor Batten - Timber	40mmX40mm Timber Floor Batten		
FCA	CARPET			
FCA-01	Carpet - axminster	 Brintons Woven Wilton Wtn 121BT Thickness: 9.2mm + 9mm backing = 18.2mm overall Colour: (purple) to match existing Underlay: Dunlop Refibre Pad 9mm thick double bonded NOTE: Brintons to provide full testing & performance specification noting that Brintons are the suppliers of carpet throughout the SOH.	FOH	
FCA-02	Carpet - axminster	 as per FCA-01 but different colour Colour: (brown) to match existing	BOH	
FCA-03	Carpet - axminster	 as per FCA-01 but different colour Colour: (red) to match existing	BOH	
FAF	ACCESS FLOOR			





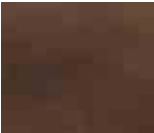



Ref. Code	General Description	Detailed / Proprietary Description	Indicative Location	Rev
FAF-02	Access Floor	ASP Entertainment heavy industrial grade access floor system with pedestals. Refer to manufacturers specifications.	Ante Room	
FC				
CONCRETE F				
FCP-01	Concrete off-form - Precast tread panel	TO MATCH EXISTIING SA Precast P/L or acceptable equivalent. Nosing: bull nosed leading and return edge panel Mix #847A of Tarana Granite out of Lithgow with grey and off white cement in 75/25% proportion. Finish: Honed exposed faces to 220 stone and heavy acid wash; XXXX sealed finish slip resistant class W Brass phillips head fixing. Size, spacing & grout to match existing	Panels North Foyer	
				
FCP-02	Concrete off-form - Precast tread panel	Relocated existing Precast Panels	Panels North Foyer and Eastern Passageway	
				
FCO-01	Concrete slab	(new concrete surface with levelling screed as required) For waste storage areas, service corridors & plantrooms: Refer to Applied Finishes Section - PSR-10/11		
FCO-02	Concrete insitu off-form	Concrete insitu off-form with granite aggregate Mix #847A of Tarana Granite out of Lithgow with grey and off white cement in 75/25% proportion. Finish: Honed exposed faces to 220 stone and heavy acid wash; XXXX sealed finish slip resistant class.	North Foyer Lift Entries East Passageway	
FCO-30	Concrete insitu off-form	Concrete insitu off-form as per Structural Engineers Requirements Colour and Finish to match adjacent exsiting concrete structure	North Foyer Lift Beams	
FLI				
LINOLEUM				
FLI-01	Linoleum - sheet	Forbo Marmoleum Marbled Topshield 2 Colour: Autumn Leaf Size: 2.5mm thick Code: 3425 Slip rating: R9 Substrate: Levelling screed as required NOTE: to be laid by Forbo recommended installer	BOH Ante Room BOH Store BOH Prompt and Opposite Prompt Room	
				
FLA				
FLOOR LADDER				





Ref. Code	General Description	Detailed / Proprietary Description	Indicative Location	Rev
FLA-01	Floor ladder - Step	Customized steel ladders. From 60 to 70 Finish: Dulux powdercoat safety yellow Refer to documentation details.	Catwalks	
FLA-02	Floor ladder - Step	Customized steel ladders. From 60 to 70 Finish: Dulux powdercoat safety yellow Refer to documentation details.	Catwalks	
FLA-03	Floor ladder - Wall attached Rung	Customized steel ladders. Vertical Finish: Dulux powdercoat safety yellow Refer to documentation details.	Catwalks	
FLA-04	Floor ladder - Rung	Customized steel ladders. Vertical Finish: Dulux powdercoat safety yellow Refer to documentation details.	Catwalks	
FLA-05	Floor ladder - Fold down Ladder	 Columbus Concertina Attic Ladders Heavy Duty concertina ladder in lightweight alloy Standard 15 Step, floor to floor 4300mm Opening: 700mmx1500mm Finish: Dulux powdercoat safety yellow	Fire Escape	
FLA-10	Safety Ladder Cage	Safety Ladder Cage Finish: Dulux powdercoat safety yellow	Fire Egress, Canon Port Gallery Area	
FPL FLOOR PLATE				
FPL-01	Floor Plate - Bronze	Threshold plate custom bronze profile extrusion	Lifts - Threshold & Stage Entries	
FSN STAIR NOSING				
FSN-01	Stair nosing - for carpet	 Dtac Edging Corduroy for carpet stairs Code: DE0630G Finish: gold anodised Luminance: LRV (TBC) (to achieve 30% contrast (min))	FOH stairs BOH stairs	
FSN-02	Stair nosing - for timber recessed	 Dtac Edging Corduroy for timber stairs - inset Code: DE0100B Finish: black anodised with custom bronze anodise over Luminance: LRV (TBC) (to achieve 30% contrast (min))	Auditorium	
FSN-03	Stair nosing - for timber	 Dtac Edging Corduroy for timber stairs Code: DE0100B Finish: black anodised Luminance: LRV (TBC) (to achieve 30% contrast (min))	BOH - stairs	
FTI TILE				

Ref. Code	General Description		Detailed / Proprietary Description	Indicative Location	Rev
FTI-01	Tile - ceramic to compliment existing		<p>Artemodus INAX Hanten Glazed ceramic tile</p> <p>Slip Rating: P3 R10</p> <p>Tile size: 50 x 50 including joint spacing</p> <p>Colour: SU 2031</p> <p>Lay: grid</p> <p>Joint Spacing: 2mm</p> <p>Pattern lay: refer to plans</p> <p>Grout: Ardex (epoxy) Colour to be advised</p> <p>Substrate: Levelling screed as required. Grade to waste for shower.</p>	BOH WC's	
FTI-02	Tile - Concrete		<p>40mm thick Concrete Tile on metal angles</p> <p>Slip Rating: P3 R10</p> <p>Tile size: 500 x 500 mm</p>	Rehearsal Rooms	
FTM	TIMBER FLOOR				
FTM-01	Timber floor - acoustic		<p>10mm Thick x 20mm wide Laminations of Brush Box Timber in 160mm x 160mm Parquetry Tiles</p> <p>Note: This is an acoustic floor with specialist underlay treatment - refer to drawings for detail.</p> <p>Finish: Refer to Applied Finishes Section</p>	<p>Rehearsal Room 1</p> <p>Rehearsal Room 2</p>	
FTM-10	Timber Floor - new		<p>Allow for 20mm Thick x 20mm Wide Laminations of Brush Box Timber on 19mm Thick Plywood CD Grade Substrate. Refer to drawing details for acoustic properties</p> <p>Finish: Refer to Applied Finishes Section</p>	FOH Stage	
FTM-11	Timber Floor - sand & re-seal		<p>sand smooth & re-seal existing laminated brushbox flooring.</p> <p>Finish: Refer to Applied Finishes Section</p>	FOH Auditorium	
FTM-12	Timber Floor - new		<p>40mm Thick 25 mm wide laminations of Brushbox to match existing</p>	FOH Auditorium	
FTM-15	Timber - Plywood Substrate		Plywood Sheet Substrate - 15mm thick Grade CD		

Ref. Code	General Description	Detailed / Proprietary Description	Indicative Location	Rev
FTM-22	Timber - Plywood Substrate	Plywood Sheet Substrate - 19mm thick Grade CD		
FTM-23	Timber - Plywood Substrate	Plywood Sheet Substrate - 25mm thick Grade CD		
FTS	TACTILE SURFACE INDICATORS			
FTS-01	Tactile - metal	DTAC warning tactile classic brass with shaft	1. Select stair 2. for additional guidance for sight impaired	
				
FVI	VINYL			
FVI-01	Vinyl tile - anti static	Forbo Colorex EC Plus vinyl tile Colour: Autumn Leaf Size: 10.5mm thick Code: 621004 montblanc Substrate: Levelling screed as required	BOH east/West Rack Rooms	
				
W. WALL & WALL COMPONENTS				
WBL	BLOCKWORK			
WBL-01	Blockwork	Existing painted blockwork with paint finish. Finish: Refer to Applied Finishes Schedule	BOH	
WBL-02	Blockwork	Boral smooth faced concrete blocks Size: 440w x 215h x 140d Finish: Refer to Applied Finishes Section	BOH	
WBA	WALL BATTENS			
WBA-03	Aluminium Split Batten System	6mm ATKAR AMC061 or similar approved aluminium extrusion gravity split batten. Finish: Anodised grey or as		
WBA-25	Wall Batten System	Rondo 25mm Top Hat Wall Betten or similar		
WBA-35	Wall Batten System	Rondo 35mm Top Hat Wall Betten or similar		
WFC	COMPRESSED FIBRE CEMENT SHEET			
WFC-03	Villaboard - 9mm thick	9mm Villaboard or similar approved compressed fibre cement boards. Exotec or similar	Wet Areas substrate Lifts	
WMC	METAL CLADDING			
WMC-01	Metal - bronze finish	Bronzeworks Bronze No. 3 finish - custom folded to all leading edges. Mount: laminate to 19mm MR Plywood substrate Fabricated Panel size: refer to detail. Hanging System: metal gravity batten hang.	FOH	
				

Ref. Code	General Description		Detailed / Proprietary Description	Indicative Location	Rev
WMC-02	Metal - Stainless Steel Black Satin/linish		Rimex Metal Cladding - custom folded to all leading edges. Material: Grade 305, 0.8mm thick stainless steel sheet. Finish: Factory chemically coloured Black - Satin/Linish finish Mount: laminate to 19mm MR Plywood substrate Fabricated Panel size: refer to detail. Hanging System: metal gravity batten hang.	Eastern Passageway	
WMC-03	Metal - bronze finish		Bronzeworks Bronze No. 3 finish - custom folded to all leading edges. Fabricated Panel size: refer to detail. Hanging System: Packed with timber sections and screw fixed	Lift 29 and 30 Entry Reveal - Portal, Stage Lighting Pods	
WMC-04	Metal - Aluminium Black Satin		Aluminium with standard and/or custom folded profiles Finish: Powdercoated Black - Satin	Eastern Passageway Curtain Pelmet	
WMC-05	Metal - Aluminium Sheet		1.6mm Locker Perforated Aluminium Sheet Product Code: R03230 Finish: Powdercoated White - Satin	Winch Room	
WMC-06	Metal - Steel Sheet		1.5mm Steel Sheet	Winch Room	
WPB	PLASTERBOARD				
WPB-02	Plasterboard - 13mm standard		Gyprock or similar approved Flush Plasterboard - standard paperfaced - 13mm Finish - Refer to Applied Finishes section	BOH	
WPB-11	Plasterboard - 13mm acoustic		Gyprock or similar approved Flush Plasterboard - Soundchek acoustic - 13mm Finish - Refer to Applied Finishes section	BOH	
WPB-21	Plasterboard - 13mm fire resistant		Gyprock or similar approved Flush Plasterboard - Fyrchek fire resistant - 13mm Finish - Refer to Applied Finishes section	BOH	
WPB-22	Plasterboard - 16mm fire resistant		Gyprock or similar approved Flush Plasterboard - Fyrchek fire resistant - 16mm Finish - Refer to Applied Finishes section	BOH	
WPB-32	Plasterboard - 16mm fire & wet resistant		Gyprock or similar approved Flush Plasterboard - Fyrchek MR fire resistant & wet resistant- 16mm Finish - Refer to Applied Finishes section	BOH	
WPB-41	Plasterboard - 13mm impact resistant		Gyprock or similar approved Flush Plasterboard - Impactchek impact resistant - 13mm Finish - Refer to Applied Finishes section	BOH	
WSK	SKIRTING				
WSK-01	Skirting - profile aluminium		Criterion Industries Decorum Shadowline skirting Size: 100high x thickness to suit 13mm plasterboard Finish: Refer to Applied Finishes Section - PPO-01 Code: CI-2391	BOH	

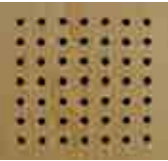
Ref. Code	General Description		Detailed / Proprietary Description	Indicative Location	Rev
WSK-02	Skirting - Metal Stainless Steel Black Satin Finish		As per WMC-02	Eastern Passageway	
WSK-03	Skirting - MDF		MDF skirting Size to match existing Finish to match existing	East and West Rack rooms	
WTI TILING					
WTI-01A	Tile - ceramic to compliment existing		Artemodus INAX Hanten Glazed ceramic tile Slip Rating: P3 R10 Tile size: 50 x 50 including joint spacing Colour: SU 2031 Lay: grid Joint Spacing: 2mm Pattern lay: refer to plans Grout: Ardex (epoxy) Substrate: FC sheet with membrane		
WTM TIMBER					
WTM-01A	Timber - Brush Box to match existing		Brush Box timber panels with deep profile cut acoustic diffusion pattern constructed from 30mm wide laminated strips - refer to drawings for overall panel thickness Seal Coat: refer to P.Applied Finishes - PST-01	Acoustic Diffusion Panels (Deep Pattern)	
WTM-01B	Timber - Brush Box to match existing		Brush Box timber panels with shallow profile cut acoustic diffusion pattern constructed from 30mm wide laminated strips - refer to drawings for overall panel thickness Seal Coat: refer to P.Applied Finishes - PST-01	Acoustic Diffusion Panels (Shallow Pattern)	
WTM-01C	Timber - Brush Box to match existing		Brush Box timber panels no profile New panels constructed from Nom. 30mm wide x 20mm thick laminated strips to match adjacent acoustic diffusion panels	Acoustic Diffusion Panels (No Pattern)	
WTM-01D	Timber - Brush Box to match existing		Brush Box timber panels no profile New panels constructed from Nom. 30mm wide x 40mm thick laminated strips to match adjacent acoustic diffusion panels	Acoustic Diffusion Panels (No Pattern)	
WTM-02	Timber - Brush Box to match existing		Combination of relocated existing Brush Box timber panels and new brush box panels to match existing. New panels constructed from Nom. 20mm x 20mm thick laminated strips to match existing. Seal Coat: refer to P.Applied Finishes - PST-01	Box Front Side & Top Panels. Theatre Entries	
WTM-03	Timber - Brush Box to match existing		12mm thick x 20mm wide Brush Box Timber Laminations on 12mm Thick Plywood CD Grade Substrate - Refer to Details for exceptions Seal Coat: refer to P.Applied Finishes - PST-01	Stage/Stage Lifts Vertical Faces	
WTM-04	Timber - To match existing		3/4" thick glue laminated brushbox face panelling made up generally of 3/4" wide battens in 3 & 4 laminate planks with 3/4" gap between. Glued and fixed to framing - back fixing only Seal Coat: refer to P.Applied Finishes - PST-01	East and West Foyers	



Ref. Code	General Description		Detailed / Proprietary Description	Indicative Location	Rev
WTM-05	Timber - Brush Box to match existing		Combination of relocated existing Brush Box timber panels and new brush box panels to match existing. Panel thickness, board widths, mesh backing and timber finish all to match existin. Cut to size as required by new geometry. It required refinishing. Seal coat: refer to P.Applied Finishes - PST-01	Stair from Ante Room to Rehearsal Room	
WTM-10	Timber - Plywood Panels		Hoop Pine Plywood Sheet - Non Perforated - 25mm thick Grade BD Seal coat: refer to P.Applied Finishes - PST-01	Ante Room	
WTM-11	Timber - Plywood Panels Perforated		Hoop Pine Plywood Sheet - Perforated - 25mm thick Grade BD Seal coat: refer to P.Applied Finishes - PST-01	Ante Room	
WTM-12	Timber - Plywood Panels Perforated		Hoop Pine Plywood Sheet - Custom Perforated - 7mm thick bendy ply Grade AC Paint Finish: refer to P.Applied Finishes - PPF-15b	Acoustic Drawers	
WTM-20	Timber - Plywood Substrate		Plywood Sheet Substrate - 6mm thick Grade CD		
WTM-21	Timber - Plywood Substrate		Plywood Sheet Substrate - 12mm thick Grade CD		
WTM-22	Timber - Plywood Substrate		Plywood Sheet Substrate - 19mm thick Grade CD		
WTM-23	Timber - Plywood Substrate		Plywood Sheet Substrate - 25mm thick Grade CD		
WTM-24	Timber - Plywood Substrate		Ply Bandy - Austral Ply Plywood Sheet Substrate - 7mm thick		
WTM-25	Timber - MDF Substrate		MDF Sheet Substrate - 3mm thick		



WTV	TIMBER VENEER				
WTV-01	Timber Veneer - acoustic custom folded		Straight and curved plywood panels with veneer overlay to seen face. Veneer: select grade white birch rotary cut Size: size, radius, perforation & thickness to match existing 'wobbly' panels. Backing: black metal flywire to match existing Acoustic batts: black - density & thickness to Acoustic Specification) Finish: Refer to P. Applied Finishes Section - PST-01 Fixing: conceal fix	BOH - Replacement of damaged existing	

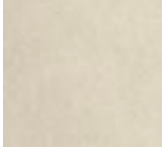



Ref. Code	General Description	Detailed / Proprietary Description	Indicative Location	Rev
WTV-02	Timber Veneer - Flat faces	Veneer: select grade white birch rotary cut - colour selected to match existing panels. Flat surfaces Size: 12mm thick. Finish: Refer to P. Applied Finishes Section - PST-01 Fixing: Refer to Details	Doors	
WTV-03	Timber Veneer - Flat faces	Plywood panels with veneer overlay to seen face. Veneer: select grade white birch rotary cut - colour selected to match existing panels. Flat surfaces Size: 12mm thick. Finish: Refer to Applied Finishes Section - PST-01 Fixing: Refer to Details	Concert Hall Ceiling Upper Walls	
WTV-04	Timber Veneer - Flat faces	Plywood panels with veneer overlay to seen face. Veneer: select grade white birch rotary cut - colour selected to match existing panels Size: 19mm thick. Finish: Refer to Applied Finishes Section - PST-01 Fixing: Refer to Details	Rehearsal Room Walls	
WTV-05	Timber Veneer - Bendy faces	 Plywood panels with veneer overlay to seen face. Veneer: select grade white birch rotary cut - colour selected to match existing panels Size: 3 layers of 7mm thick. Finish: Refer to Applied Finishes Section - PST-01 Fixing: Refer to Details	Concert Hall Ceiling Lower Walls	



C. CEILING



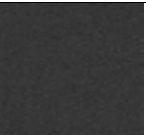

CAH	CEILING ACCESS HATCH		
CAH-01	Ceiling Access Hatch	Ceiling hatch Constructed to maintain ceiling reflectivity and attenuation.	Concert Hall Ceiling
CAI	ACOUSTIC INSULATION		
CAI-02	Acoustic - exposed panels	 Autex Quietspace 100% PET acoustic panels Size: 1200 x 2400 x 25mm thick Colour: Opera Acoustic performance: NRC: 0.85 Lay: butt join to length, offset 50mm to width, running parallel to window Installation: refer to manufacturers guidelines. This product is direct stuck to suspended plasterboard.	Select Dressing Rooms
CEX	EXISTING CEILING		
CEX-01		Existing exposed painted concrete ceiling. Finish: Refer to Applied Finishes section - PPF-04	
CFG	COMPOSITE		
CFG-01	Composite Acoustic Reflectors	Shapeshell composite material or similar approved material. Weight to achieve 10kg/m2 minimum.	Concert Hall
CMC	CEILING METAL CLADDING		

Ref. Code	General Description	Detailed / Proprietary Description	Indicative Location	Rev
CMC-01	Ceiling Metal Cladding	Bronzeworks Bronze No. 3 finish - custom folded to all leading edges. Mount: laminate to substrate Fabricated Panel size: refer to detail.	Lifts	
CPB PLASTERBOARD				
CPB-02	Plasterboard - Standard	Gyrock or similar approved Flush Plasterboard - standard paperfaced - 13mm thick square set unless noted otherwise. Suspension: Rondo to suit Paint finish: Refer to Applied Finishes section		
CPB-11	Plasterboard - Acoustic	Gyrock or similar approved Flush Plasterboard - Soundchek acoustic - 13mm thick square set unless noted otherwise. Suspension: Rondo to suit Paint finish: Refer to Applied Finishes section		
CPB-12	Plasterboard - Acoustic Perforated	Gyrock or similar approved Flush Plasterboard - Rigitone Galaxy acoustic perforated - 13mm thick square set unless noted otherwise. Suspension: Rondo to suit Paint finish: Refer to Applied Finishes section		
CPB-41	Plasterboard - impact	Gyrock or similar approved Flush Plasterboard - Impactchek impact resistant - 16mm thick square set unless noted otherwise. Suspension: Rondo to suit Paint finish: Refer to Applied Finishes section		
CRN RENDER				
CRN-01	Render - Concrete	Parchem Construction Products Renderoc FC Finish coat: clear water based sealer Durafloor HD System.		
CTV TIMBER VENEER				
CTV-01	Timber Veneer- Existing custom formed perforated Relocated or Reinstated	 Reinstated Existing plywood with select grade birch veneer rotary cut overlay to seen face. Size: size, radius, perforation & thickness to match existing. Backing: existing black metal flywire Acoustic batts: black - density & thickness to Acoustic Specification) Finish: Refer to Applied Finishes Section - PST-01	BOH - Reinstated or Relocated existing	
CTV-01A	Timber Veneer - New custom formed perforated to match existing	 Straight and curved plywood panels with veneer overlay to seen face. Veneer: select grade white birch rotary cut Size: size, radius, perforation & thickness to match existing 'wobbly' panels. Backing: black metal flywire to match existing Acoustic batts: black - density & thickness to Acoustic Specification) Finish: Refer to Applied Finishes Section - PST-01 Fixing: conceal fix	BOH - Replacement of damaged existing	
CTV-02	Timber Veneer- Existing custom formed perforated Relocated or Reinstated	 As per CTV-01 but hung in reverse	BOH - Reinstated or Relocated existing	

Ref. Code	General Description	Detailed / Proprietary Description	Indicative Location	Rev
CTV-02A	Timber Veneer - New custom formed perforated to match existing	 As per CTV-01A but hung in reverse	BOH - Replacement of damaged existing	
CTV-03	Timber Veneer - Flat faces	 Plywood panels with veneer overlay to seen face. Veneer: select grade white birch rotary cut - colour selected to match existing panels Size: 12mm thick. Finish: Refer to Applied Finishes Section - PST-01 Fixing: Refer to Details	Concert Hall Ceiling	
CTV-04	Timber Veneer - Bendy faces	Plywood panels with veneer overlay to seen face. Veneer: select grade white birch rotary cut - colour selected to match existing panels Size: 3 layers of 7mm thick. Finish: Refer to Applied Finishes Section - PST-01 Fixing: Refer to Details	Concert Hall Ceiling Acoustic Reflectors Rehearsal Room Ceilings	
CTM	TIMBER			
CTM-01	Brush Box Timber to match existing	Combination of relocated existing Brush Box timber panels and new brush box panels to match existing. Panel thickness, board widths, mesh backing and timber finish all to match existing. Existing relocated Panels cut to size to suit new Design.	FOH Foyer Ceiling Panels	
CTM-11	Timber - Plywood Panels Perforated	Hoop Pine Plywood Sheet - Perforated - 25mm thick Grade BD Sealcoat: Refer to Applied Finishes - PST-01	Ante Room	
J. JOINERY				
JIT Joinery Item				
JIT-01		Makeup Desk - carcass construction 38mm MDF - benchtop construction 32mm MDF - shelving 25mm MDF - door & drawer fronts to be 18mm MDF - white melamine finish to all internal surfaces both faces - Designer Doorware Lip Pull with Return Code 3750-150 for drawers - Designer Doorware Lip Pull with Return Code 3750-300 for doors - Hafele Grass G300 concealed hinges, 110 degrees soft close - Hafele Nova Pro white deluxe drawers with airmatic runners, full extension, soft close - Hafele Wardrobe Rail - chrome with fluted design	Dressing Rooms	
JIT-02		Table Table Dimensions: 700 x 2080mm Top Carcass: 32mm Legs (4) Zenith Talki, Fixed height 720mm Leg Finish: Powdercoat White - 20mm shadowline detail to wall junctions &	Locker Room	
GENERAL NOTE				

Ref. Code	General Description	Detailed / Proprietary Description	Indicative Location	Rev
<p>Unless otherwise noted</p> <ul style="list-style-type: none"> - carcass construction 38mm MDF - benchtop construction 32mm MDF - white melamine finish to all internal surfaces both faces 20mm shadowline detail to wall junctions & 				
JMI MIRROR				
JMI-01	Mirror		Silver backed mirror with polished edges, frameless. Size: 600 wide x 2000 high Mounting board : Astral Plywood A-C grade 12mm thick Plywood Finish to all seen faces: Refer to Applied Finishes Section - PST-01 Mount: metal gravity batten hang	Dressing Rooms
JMI-02	Mirror		Silver backed mirror with polished edges, frameless. Size: 1000 wide x 1000 high Mounting board : Astral Plywood A-C grade 12mm thick NOTE integral to Makeup joinery unit	Dressing Rooms - makeup desk
JMI-03	Mirror		Silver backed mirror with polished edges, frameless. Size: 500 wide x 1000 high Mounting board : Astral Plywood A-C grade 12mm thick flexible ply moulded to radius to create 150d shelf. Wall mount: Float mount 30mm Front face finish: Refer to JSF-10	Dressing Rooms - Ensuite
JMI-04	Mirror		as per JMI-02 but different size Size: 400 x 1000 high	DDA compliant WC's
JMI-05	Mirror		as per JMI-01 but different size Size: 1000 x 2000 high Framing system TBC	Ensuite WC's
JPB PINBOARD				
JPB-01	Pinboard		Forbo Bulletin Board Size: 600w x 2000h x 6mm thick Colour: 2209 black olive NOTE: mount to 8mm MDF backing board with thin profile black anodised aluminium L section. Float mount 6mm	Dressing Rooms
JSF SPECIALITY FINISH				
JSF-01	Corian		Corian solid surface Sheet size: 2490 x 760 x 6mm thick cut to size Colour: Glacier White Profile: mould to radius - refer to JMI-03	Dressing Rooms - Locker room
BLF-30	Light		Euroluce Flos Mini Glo-ball suitable for ceiling, wall & mirror. Note: Allow for 6no per makeup mirror.	Dressing Rooms - makeup desk
JTV TIMBER VENEER				

Ref. Code	General Description	Detailed / Proprietary Description	Indicative Location	Rev
JTV-01		Navlam Sand Blasted Beechwood compact veneer laminate seen front faces. White melamine all internal faces. Edge Trim: Nav Diverso ABS Edgebanding - Lamora Oak Ply	Makeup Desks Locker door fronts & exposed side faces Wardrobe door fronts & exposed side faces	
JTV-01a		as per JTV-01 but different colour & no ABS edge strip Navlam Sandblasted Black Pearl	Makeup Desk skirt Wardrobe skirt	
JTS	TIMBER SOLID			
JTS-01		select furniture grade White Birch		
M. MISCELLANEOUS FIXTURES & FITTINGS				
MAC	MISCELLANEOUS ACCESSORIES			
MAC-01	Acoustic Banner Box	Refer to Schuler Shoock documentation for details Finishes refer to architectural detail	Auditorium	
MAC-02	Acoustic Ceiling Reflector	Refer to architectural detail	Rehearsal Rooms	
MAC-03	Acoustic Wall Reflector	Refer to architectural detail	Rehearsal Rooms	
MMA	MISCELLANEOUS MATERIAL			
MMA-01	Miscellaneous Material - SeatingFabric	 Macquarie Textiles 100% Wool Custom commercial upholstery SOH Colour: Purple & Jet Basecloth Number: 7689	Concert Hall Stall and Circle seating	
BALUSTRADES, SCREENS & HANDRAILS		Refer to Grimshaw documentation. codes as per Grimshaw's documentation.	All FOH Balustrades	
BAR-100	Balustrade	Refer to Grimshaw documentation	North Foyer Stairs	
BAR-300	Balustrade	Refer to Grimshaw documentation	Tunnel Barrier	
GR-300	Balustrade	Refer to Grimshaw documentation	West/East Foyer Stairs	
HR-100	Handrail	Refer to Grimshaw documentation	North Foyer Lifts	
BAR-300/1	Balustrade	HP 02 Bronze profile with PP 01 vertical bronze profile posts Height typically 925mm Refer to Grimshaw documentation	East Passageway	
HR-300/1	Guardrail	GP 01 Bronze profile with vertical 25mm square bronze profile posts. Height to match existing Refer to Grimshaw documentation	Auditorium	
GR-200	Balustrade	HP 01 Bronze profile with HB 01 vertical bronze profile posts. Height typically 925mm Refer to Grimshaw documentation	Auditorium	
MBA-01	Access Walkway - Safety Barrier	Webforge Monowills Webforge steel staunchions with mid rail and kickplate. Fixed with baseplates, spacing 2000mm. To comply with AS1428.1 Finish: Dulux powdercoat safety yellow	Tech Zone South	

Ref. Code	General Description	Detailed / Proprietary Description	Indicative Location	Rev
MHR-01	Handrail	50mm diameter steel pipe Finish: Paint Code XXX	BOH	
MHR-02	Handrail	50mm diameter steel pipe with 50mm square posts Finish: Paint Code XXX	BOH	
MHR-03	Handrail - Grimshaw to provide code	32mm diameter bronze pipe with 32mm diameter bronze posts Removable or fixed Finish: Refer to Grimshaw documentation	BOH	
MCU	CURTAIN	NOTE: ACOUSTIC BANNERS TO SEPERATE COST ALLOWANCE		
MCU-01	Curtain - decorative	 Select fabric. Allow \$200 per square metre Fold: 100% (note: this requires length measure to be doubled to accommodate fold) Tracks: specialist from Jands Operation: fixed	FOH East Passageway	
MCU-02	Curtain - acoustic	 Select fabric. Allow \$100 per square metre Fold: 100% (note: this requires length measure to be doubled to accommodate fold) Tracks: specialist from Jands Operation: automated	Rehearsal Rooms 1 & 2	
MFS	FIXED SHELF			
MLK	LOCKERS			
MLK-01	Lockers - single tier	  DigiLock Celare Phenolic Style Lockers single tier, continuous runs wall to wall. Complete with ventilated back panels, hidden soft close hinges, coat rod & hooks & hat shelf. Include corner infill panels - (arrives fully assembled). Size: 410w x 1930h x 550d Colour: Waterfall 10501-65 Locking: Axis Keypad with pull handle- battery operated (3-5 year lifespan) complete with handle as illustrated	Locker Rooms	
MPR	PICTURE RAIL			
MPR-01	Picture Rail - top recessed	 Picture Hanging Systems Beta Bos2 picture rail Finish for timber walls: black satin powdercoat Finish for plasterboard walls: white satin powdercoat Installation: recess fixed at wall/ceiling junction. Refer to drawing detail.	select BOH	
B. BUILDING SERVICES				
BLI-01	Lift - new	Refer to Liftcar drawing set	FOH Patron Lifts	

Ref. Code	General Description	Detailed / Proprietary Description	Indicative Location	Rev
BLL-02	Lift - refurbish existing	 <p>Works to include:</p> <ol style="list-style-type: none"> 1. Complete refit of existing interior. 2. Complete reclad of existing door frames & architrave <p>Lift Door Cladding Existing stainless steel be reclad in Bronzeworks Bronze No 3 finish both faces</p> <p>Architrave: existing stainless steel to be replaced with revised profile architrave Bronzeworks Bronze No 3 finish</p> <p>Handrails & Spigots: new handrails with concealed spigot detail - brass</p> <p>Floor tile: Signorino Pietra di Savoia Anthracite 5.5mm</p> <p>Wall Cladding: Signorino Pietra di Savoia Anthracite 5.5mm with brass trim</p> <p>Ceiling Cladding: Rimex Mirror finish</p> <p>Lighting: Recess strip LED to 3 sides (TBA)</p> <p>COP (Car Operating Panel): DDA compliant brass with LED (TBA)</p> <p>LCS (Landing Call Station): DDA compliant brass steel with LED (TBA)</p> <p>HL (Hall Lantern): DDA compliant brass with LED (TBA)</p>	FOH Service Lifts	
BFH	Fire Hydrant	Refer to Fire Consultants drawings		
BFR	Fire Hose Reel	Refer to Fire Consultants drawings		
P. APPLIED FINISHES				
INTERIOR				
PFR-01	Fire Rated - intumescent paint	<p>Promat CAFCO® Sprayfilm WB3 Intumescent Coating System to Primed Steel Rate Structural Steel:</p> <p>Achieve 120min FRL (120/-/-)</p> <p>Finish: paint to colour match acoustic spray on - refer to C.AI.</p> <p>Steel members required to be fire rated shall have CAFCO® Sprayfilm WB3 Water Borne Intumescent Coating applied to the relevant thickness detailed in the Specifier's Drawings to achieve an FRL (120/-/-) in accordance with AS1530 Part 4 - 2005 and AS4100, and BCA Spec A2.3 Part3. Preparation of the steel to Class 2 AS1627 Part 4 or Sa2.5, steel substrate primed within 4hrs of blast clean using 75micron DFT Dulux compatible primer as specified, or as per Promat CAFCO® Sprayfilm WB3 Primer & Top Seal Compatibility List. All in accordance with the manufacturer's printed instructions. Top coat application using Dulux as specified. All work to be certified by an approved applicator.</p>		
PPF-02	Paint - Acrylic Low Sheen for Plasterboard Walls	<p>Dulux Wash n Wear Advance Low Sheen on plasterboard New Interior</p> <p>Spec Sheet Code: AUSD0002</p>		
PPF-02a		Colour Code: (light)		

Ref. Code	General Description	Detailed / Proprietary Description	Indicative Location	Rev
PPF-02b		Colour Code: (dark)		
PPF-03	Paint - Acrylic Semi Gloss for plasterboard walls & ceiling	Dulux Wash n Wear Kitchen & Bathroom Semi Gloss on Plasterboard New Interior Spec Sheet Code: AUSD4848		
PPF-03a		Colour Code: (light)		
PPF-03b		Colour Code: (dark)		
PPF-04	Paint - Acrylic Low Sheen for Concrete Blockwork Walls, Insitu & Precast Concrete & Fibre Cement Sheet	Dulux Low Sheen Acrylic Premium Spec Sheet Code: AUSD3284		
PPF-04a		Colour Code: (light)		
PPF-04b		Colour Code: (dark)		
PPF-10	Paint - Acrylic Flat Plasterboard Ceilings	Dulux Professional Enviro02 Tintable Ceiling Flat on Plasterboard New Interior Spec Sheet Code: AUSD4308		
PPF-10a		Colour Code: (light)		
PPF-10b		Colour Code: (dark)		
PPF-15	Paint - Wash & Wear Matt on New Plywood	Dulux Wash & Wear Matt on New Plywood New Interior Spec Sheet Code: AUSD12531		
PPF-15a		Colour Code: (light)		
PPF-15b		Colour Code: (dark)		
PPF-20	Paint - Enamel Gloss Timber Doors/Windows/Trim	Dulux Super Enamel Gloss/Professional oil undercoat for Timber New Interior Specification Sheet Code: AUSD4603		
PPF-20a		Colour Code: (light)		
PPF-20b		Colour Code: (dark)		
PPF-30	Paint - Enamel Gloss New Metal Pre-primed Metal Doors & Pressed Metal Frames	Dulux Super Enamel Gloss/Professional oil undercoat for Metal New Interior Specification Sheet Code: AUSD4603		
PPF-30a		Colour Code: (light)		
PPF-30b		Colour Code: (dark)		
PPF-31	Paint - Enamel Gloss New Metal Canopy & Column Trim	Akzonobel International Paints Semi Gloss Paint System Intercure 200 with Interthane 990 topcoat Data Sheet Code: 130614-BMUTIM-17C1/4		
PPF-31a		Colour Code: (light)		
PPF-31b		Colour Code: (dark)		

Ref. Code	General Description	Detailed / Proprietary Description	Indicative Location	Rev
PPF-40	Custom Paint Finish	Custom paint finish (Black/Pink Pearlescent) to all visible surface comprising: Colorbuild Plus Ecp - tinted undercoat Autobase Plus MM - two way pearlescent topcoat system Autoclear Plus HS - Clear gloss finishing coat system.		
PPO-01	Powdercoat	Dulux Duralloy (select colour)		
PPO-02	Powdercoat	Dulux Duralloy (select colour)		
PSR-10	Slip Resistant Coating - concrete	Sika Sikafloor 264T - 3 COAT SYSTEM 45 MESH FINISH Refer to Sika Data Sheet Slip rating: R11 Colour: window grey	BOH service corridors Waste Storage areas	
PSR-11	Slip Resistant Coating for plant room - concrete	as per PSR-10 but suited to chemical spills	Plantrooms	
PST-01	Seal System - timber	Mirotone Clear Coat Seal Sealer: Mirotec WB 8022 Clear Sealer Topcoat: Mirotec WB 8052/30 Clear Satin (2 coats) Refer to Mirotone Data Sheet for full preparation & application detail Builder to supply samples of both matt & satin finishes to Architect for approval	BOH timber panelling	
PST-02	Stain/seal system - timber	Mirotone "Mirostain" 4 coat wood stain system applied strictly in accordance with Manufacturer's directions: Stain: Mirostain (select colour) Seal: Fastseal 3535 Clear Primer First Topcoat: Aquapro 8270 2K Advance Satin Water Based Floor Finish Second Topcoat: Aquapro 8270 2K Advance Satin Water Based Floor Finish Refer to Mirotone Data Sheet for full preparation & application detail		
S. STRUCTURAL COMPONENTS				
SCO-01	Concrete Insitu wall	Structural reinforced concrete insitu. Refer to structural engineers' details.		
SMS	METAL STUDS			
SMS-02	Metal stud wall 51mm 0.75 BMT @ 600 max. centres	Rondo or 'similar approved'. BMT & spacing requirements for all wall framing to be as per manufacturers recommendations for nominated frame size & height.		
SMS-10	Metal stud wall 64mm 0.75 BMT @ 600 max. centres	Rondo or 'similar approved'. BMT & spacing requirements for all wall framing to be as per manufacturers recommendations for nominated frame size & height.		
SMS-31	Metal stud wall 92mm 0.75 BMT @ 600 max. centres	Rondo or 'similar approved'. BMT & spacing requirements for all wall framing to be as per manufacturers recommendations for nominated frame size & height.		

Ref. Code	General Description	Detailed / Proprietary Description	Indicative Location	Rev
SMS-31a50	<i>Metal stud wall 92mm 0.75mm BMT with 50mm thick 11kg/m3 acoustic insulation @ 600 max. centres.</i>	<i>Rondo or 'similar approved'. BMT & spacing requirements for all wall framing to be as per manufacturers recommendations for nominated frame size & height.</i>		

DA0302 EXTERNAL MATERIALS & FINISHES SCHEDULE

0999 Sydney Opera House Concert Hall

PREPARED BY: PRB

ISSUE	REVISION	DATE
DA ISSUE	A	27/10/17
DA ISSUE	B	26/04/18
DA ISSUE	C	21/09/18
DA ISSUE	D	5/10/18

Ref. Code	General Description	Detailed / Proprietary Description	Indicative Location	Rev
EXTERIOR WORKS				
X.F1. GLAZING & GLASS				
X.F1	GLAZING SYSTEMS			
X.F1.01	Structurally glazed façade system on bronze and aluminium substrate	<p>Intent: Refer <FAÇADE ENGINEERING DOCUMENTATION></p> <hr/> <p>Supplier: TBC</p> <hr/> <p>Glazing framing changes:</p> <hr/> <p>Glazing: Refer <GGT-22></p> <hr/> <p>Glazing sealant: Refer <FAÇADE ENGINEERING DOCUMENTATION></p> <hr/> <p>Glazing sealant: Refer <FAÇADE ENGINEERING DOCUMENTATION></p> <hr/> <p>Sill channel – dead load: Refer <FAÇADE ENGINEERING DOCUMENTATION></p> <hr/> <p>Deflection channel: Refer <FAÇADE ENGINEERING DOCUMENTATION></p>		
GGT	GLASS TYPE			
GGT-19		<p>Supplier: SOH</p> <p>Product: Existing or stock wall glass. Annealed laminated glass with demi-topaz tint</p> <p>Min / Max. solar heat gain coefficient: Refer to <BUILDING ENERGY MODELLING DOCUMENTATION> by services consultant.</p> <p>Min / Max. U Value: Refer to <BUILDING ENERGY MODELLING DOCUMENTATION> by services consultant.</p> <p>Min / Max. Visible transmittance: Refer to <BUILDING ENERGY MODELLING DOCUMENTATION> by services consultant.</p> <p>Glass thickness: 18.8mm annealed laminated glass</p> <p>Engineering specification: <REFER FAÇADE ENGINEERING</p> <p>Colour: Demi-topaz tint</p> <hr/> <p>Connections : REFER FAÇADE ENGINEERING DOCUMENTATION></p> <hr/> <p>Joints: REFER FAÇADE ENGINEERING DOCUMENTATION></p> <hr/> <p>Sealant: REFER FAÇADE ENGINEERING DOCUMENTATION></p> <hr/> <p>Additional Comments:</p>		
GGT-22		<p>Supplier: Viridian</p> <p>Product: Heat Strengthened laminated glass with tinted PVB interlayer</p> <p>Min / Max. solar heat gain coefficient: Refer to <BUILDING ENERGY MODELLING DOCUMENTATION> by services consultant.</p> <p>Min / Max. U Value: Refer to <BUILDING ENERGY MODELLING DOCUMENTATION> by services consultant.</p> <p>Min / Max. Visible transmittance: Refer to <BUILDING ENERGY MODELLING DOCUMENTATION> by services consultant.</p> <p>Glass thickness: Refer <FAÇADE ENGINEERING DOCUMENTATION></p> <p>Glass thickness: 25.52mm (12mm HS + 1.52mm PVB + 12mm HS)</p> <p>Engineering specification: <REFER FAÇADE ENGINEERING DOCUMENTATION></p>		

Colour: Trosifol ligh brown tinte PVB

Connections : REFER FAÇADE ENGINEERING DOCUMENTATION>

Joints: REFER FAÇADE ENGINEERING DOCUMENTATION>

Sealant: REFER FAÇADE ENGINEERING DOCUMENTATION>

Additional Comments:

X.F0. WALLS

Intent: Precast Panels to match existing

Supplier: SA Precast P/L or acceptable equivalent

Type: Mix #847A of Tarana Granite out of Lighgow with grey and off white cement in 75/25% proportion

Size: nom. 110mm thick x 300mm TME to Struct detail to match existing

Finish: Honed exposed faces to 220 stone and heavy acid wash;

WSK SKIRTING TYPE

WSK-11 Bronze Skirting

Intent: Bronze skirting extruded profile.

Supplier: SOH to provide from existing

Product: To match existing geometry

Size: Cut to suit on-site dimensions by contractor

Finish: to match existing

WSK-12 Bronze Skirting

Intent: Bronze skirting extruded profile.

Supplier: SOH to provide

Product: New geometry to emulate existing geometry

Size: Cut to suit on-site dimensions by contractor

Finish: to match existing







ARM_Door Schedule																																							
Level	Door Identification				Door Details										Frame Details					Signage			Functional Requirements					Comments	Revision										
	Door Number	To Room Number	To Room Name	Door Type	Description	Rough Height	Height	Panel Height	Rough Width	Width	Panel Width 1	Panel Width 2	Number of Panels	Core Thickness	O/A Thickness	Door Finish-Inside	Door Finish-Outside	Frame Type/Material	Frame Width	Frame Height	Throat Width	Frame Finish	Door Hardware	Description	Image/Symbol	Door Panel	Security Code			Fire Rating	Smoke Seals	Acoustic Rating	Gillies						
GM +21	D.GM.01	GM.RR.01	REHEARSAL ROOM 1	DSC-01	Single Door	2080	2040	2040	1230	1150	1150	1	38	38.0		WTV-01	WTV-01	D.FR.01	1230	2090	120		REFER TO DORMAKABA XXXXX																
GM +21	D.GM.02	GM.RR.01	REHEARSAL ROOM 1	DSC-03	Single Door	2140	2100	2100	900	820	820	1	47	47.0		WTV-01	WTV-01	D.FR.03	900	2150	120		REFER TO DORMAKABA XXXXX																
GM +21	D.GM.03	GM.RR.01	REHEARSAL ROOM 1	DSC-01	Single Door	2080	2040	2040	800	720	720	1	38	38.0		WTV-01	WTV-01	D.FR.01	800	2090	202		REFER TO DORMAKABA XXXXX																
GM +21	D.GM.04	GM.74.01	eLOBBY	DSC-01	Double Door	2040	2000	2000	880	800	400	400	2	38	38.0		WTV-01	WTV-01	D.FR.01	880	2050	81		REFER TO DORMAKABA XXXXX															
GM +21	D.GM.05	GM.RR.02	REHEARSAL ROOM 2	DSC-01	Single Door	2080	2040	2040	1230	1150	1150	1	38	38.0		WTV-01	WTV-01	D.FR.01	1230	2090	120		REFER TO DORMAKABA XXXXX																
GM +21	D.GM.06	GM.ST.01	STORE	DSC-03	Single Door	2140	2100	2100	900	820	820	1	47	47.0		WTV-01	WTV-01	D.FR.03	1200	2150	120		REFER TO DORMAKABA XXXXX																
L1 -30	D.L1.01	L1.L30	LIFT 30	DSC-01	Single Door	2130	2090	2090	900	820	820	1	38	38.0		WTV-01	WTV-01	D.FR.01	900	2140	176		REFER TO DORMAKABA XXXXX																
L1 -30	D.L1.02	L1.SR.01	eCORRIDOR	DSC-01	Single Door	2130	2090	2090	900	820	820	1	38	38.0		WTV-01	WTV-01	D.FR.01	900	2140	226		REFER TO DORMAKABA XXXXX																
L1 -30	D.L1.03	L1.AM.04	DRESSING ROOM 58	DSC-02	Double Door - A Symmetrical	2140	2100	2100	1650	1140	870	870	2	70	70.0		WTV-01	WTV-01	D.FR.02	1650	2150	236		REFER TO DORMAKABA XXXXX															
L1 -30	D.L1.04	L1.AM.05	UNISEX ACCESS ENSUITE	DSC-01	Single Door	2140	2100	2100	1000	900	900	1	38	38.0		WTV-01	WTV-01	D.FR.01	1000	2150	101		REFER TO DORMAKABA XXXXX	UNISEX ACCESSIBLE WC	SHOWER UNISEX ACCESSIBLE WC SYMBOL	OUTSIDE FACE		-60/30	Yes	35Rw									
L1 -30	D.L1.05	L1.AM.03	UNISEX ACCESSIBLE WC	DSC-01	Single Door	2140	2100	2100	1000	900	900	1	38	38.0		WTV-01	WTV-01	D.FR.01	1000	2150	207		REFER TO DORMAKABA XXXXX	UNISEX ACCESSIBLE WC	SHOWER UNISEX ACCESSIBLE WC SYMBOL	OUTSIDE FACE			No	30 Rw									
L1 -30	D.L1.06	L1.AM.01	ARLOCK	DSC-01	Single Door	2130	2090	2090	900	820	820	1	38	38.0		WTV-01	WTV-01	D.FR.01	900	2140	207		REFER TO DORMAKABA XXXXX	MALE WC, SHOWERS	SHOWER SYMBOL, MALE WC SYMBOL	OUTSIDE FACE			No										
L1 -30	D.L1.07	L1.AM.01	ARLOCK	DSC-01	Single Door	2130	2090	2090	900	820	820	1	38	38.0		WTV-01	WTV-01	D.FR.01	900	2140	188		REFER TO DORMAKABA XXXXX																
L1 -30	D.L1.08	L1.AM.02	MALE PERFORMER AMENITIES	DSC-01	Single Door	2080	2040	2040	700	620	620	1	38	38.0		WTV-01	WTV-01	D.FR.01	700	2090	80		REFER TO DORMAKABA XXXXX																
L1 -30	D.L1.09	L1.AM.02	MALE PERFORMER AMENITIES	DSC-01	Single Door	2080	2040	2040	700	620	620	1	38	38.0		WTV-01	WTV-01	D.FR.01	700	2090	80		REFER TO DORMAKABA XXXXX																
L1 -30	D.L1.10	L1.OF.01	OFFICE	DSC-01	Single Swing		2311		655	655			1	44	44.0		PPF-30a	PPF-30a	D.FR.01					REFER TO DORMAKABA XXXXX															
L1 -30	D.L1.11	L1.LR.01	LOCKER ROOM	DSC-01	Single Door	2140	2100	2100	1000	900	900	1	38	38.0		WTV-01	WTV-01	D.FR.01	1000	2150	78		REFER TO DORMAKABA XXXXX																
L1 -30	D.L1.12	L1.LR.01	LOCKER ROOM	DSC-01	Single Door	2150	2100	2100	1020	920	920	1	38	38.0		WTV-01	WTV-01	D.FR.01	1000	2150	146		REFER TO DORMAKABA XXXXX																
L1 -30	D.L1.13	L1.RR.01	RACK ROOM	DSC-03	Single Door	2140	2100	2100	1000	900	900	1	47	47.0		WTV-01	WTV-01	D.FR.03	1000	2150	120		REFER TO DORMAKABA XXXXX	RACK ROOM - AUTHORISED ACCESS ONLY															
L1 -30	D.L1.14	L1.AM.13	ARLOCK R60	DSC-01	Single Door	2140	2100	2100	1000	900	900	1	38	38.0		WTV-01	WTV-01	D.FR.01	1000	2150	196		REFER TO DORMAKABA XXXXX																
L1 -30	D.L1.15	L1.ST.01	STORE	DSC-03	Single Door	2140	2100	2100	1000	900	900	1	47	47.0		WTV-01	WTV-01	D.FR.03	1000	2150	94		REFER TO DORMAKABA XXXXX																
L1 -30	D.L1.16	L1.AM.10	DRESSING ROOM 75	DSC-03	Single Door	2140	2100	2100	1000	900	900	1	47	47.0		WTV-01	WTV-01	D.FR.03	1000	2150	126		REFER TO DORMAKABA XXXXX	ARLOCK TO UNISEX ACCESSIBLE WC	SHOWER UNISEX ACCESSIBLE WC SYMBOL	OUTSIDE FACE		120x60/30	Yes	30Rw									
L1 -30	D.L1.17	L1.AM.11	BATHROOM	DSC-01	Single Door	2130	2090	2090	900	820	820	1	38	38.0		WTV-01	WTV-01	D.FR.01	900	2140	157		REFER TO DORMAKABA XXXXX	UNISEX WC	UNISEX WC SYMBOL	OUTSIDE FACE			No	30 Rw									
L1 -30	D.L1.18	L1.AM.12	ACCESS BATH	DSC-01	Single Door	2140	2100	2100	1000	900	900	1	38	38.0		WTV-01	WTV-01	D.FR.01	1000	2150	157		REFER TO DORMAKABA XXXXX	UNISEX ACCESSIBLE WC, SHOWER	SHOWER UNISEX ACCESSIBLE WC SYMBOL	OUTSIDE FACE			No	30 Rw									
L1 -30	D.L1.19	L1.AM.06	ARLOCK R 76	DSC-03	Single Door	2140	2100	2100	1000	900	900	1	47	47.0		WTV-01	WTV-01	D.FR.03	1000	2150	176		REFER TO DORMAKABA XXXXX	UNISEX ACCESSIBLE WC	SHOWER UNISEX ACCESSIBLE WC SYMBOL	OUTSIDE FACE			120x60/30	Yes									
L1 -30	D.L1.20	L1.AM.08	ACCESS BATH	DSC-01	Single Door	2140	2100	2100	1000	900	900	1	38	38.0		WTV-01	WTV-01	D.FR.01	1000	2150	135		REFER TO DORMAKABA XXXXX	UNISEX ACCESSIBLE WC, SHOWER	SHOWER UNISEX ACCESSIBLE WC SYMBOL	OUTSIDE FACE			No										
L1 -30	D.L1.21	L1.AM.07	DRESSING ROOM 76	DSC-01	Single Door	2140	2100	2100	1000	900	900	1	38	38.0		WTV-01	WTV-01	D.FR.01	1000	2150	85		REFER TO DORMAKABA XXXXX																
L1 -30	D.L1.22	L1.SD.01	eCORRIDOR	DSC-01	Single Door	2140	2100	2100	1000	900	900	1	38	38.0		WTV-01	WTV-01	D.FR.01	1000	2150	176		REFER TO DORMAKABA XXXXX																
L1 -30	D.L1.23	L1.L29	LIFT 29	DSC-01	Single Door	2130	2090	2090	900	820	820	1	38	38.0		WTV-01	WTV-01	D.FR.01	900	2140	176		REFER TO DORMAKABA XXXXX																
L2 +42	D.L2.01	251HA1	eUPBOARD	DSC-01	Double Door	2040	2000	2000	1220	1140	570	570	2	38	38.0		WMC-01	WMC-01	D.FR.01	1220	2050	120		REFER TO DORMAKABA XXXXX	FIRE HOSE REEL CLIPBOARD	FIRE HOSE REEL SYMBOL	OUTSIDE FACE			No									
L2 +42	D.L2.02	L2.EP.01	EAST PASSAGEWAY	DSP-01	Double Door - A Symmetrical	2140	2100	2100	1250	1170	585	585	2	38	38.0		WMC-01	WMC-01	D.FR.03	1250	2150	132		REFER TO DORMAKABA XXXXX	SERVICES CLIPBOARD														
L2 +42	D.L2.03	L2.S15	eSTAR 15 LOBBY	DSP-01	Double Door	2140	2100	2100	1980	1900	950	950	2	38	38.0		WMC-01	WMC-01	D.FR.06	1980	2150	132		REFER TO DORMAKABA XXXXX							-120/30	Yes							
L2 +42	D.L2.04	L2.EP.01	EAST PASSAGEWAY	DSP-01	Double Door - A Symmetrical	2140	2100	2100	1400	1320	885	435	2	38	38.0		WMC-01	WMC-01	D.FR.03	1400	2150	132		REFER TO DORMAKABA XXXXX	SERVICES CLIPBOARD														
L2 +42	D.L2.05	L2.AL.01	ARLOCK	DSP-01	Double Door	2140	2100	2100	1980	1900	950	950	2	38	38.0		WTV-01	WTV-01	D.FR.03	1980	2150	256		REFER TO DORMAKABA XXXXX															
L2 +42	D.L2.06	L2.S1.01	STORE	DSC-01	Double Door	2140	2100	2100	1980	1900	950	950	2	38	38.0		WTV-01	WTV-01	D.FR.01	1980	2150	94		REFER TO DORMAKABA XXXXX															
L2 +42	D.L2.07	L2.AE.01	ACCESSIBLE THEATRE ENTRY EAST	DSC-03	Double Door - A Symmetrical	2140	2100	2100	2720	2640	1420	1220	2	70	70.0		WTM-01a	WTM-01a	D.FR.04	2720	2150	156		EXISTING	ACCESSIBLE THEATRE ENTRY	EMERGENCY EXIT SYMBOL	INSIDE FACE		-60/30	Yes	35Rw						USE HARDWARE FROM EXISTING DOOR CS025		
L2 +42	D.L2.08	L2.AL.02	OPPOSITE PROMPT	DST-01	Double Door	2285	2245	2245	2630	2530	1253	1253	2	120	120.0		WTM-01a	WTM-01a	D.FR.05			166		REFER TO DORMAKABA XXXXX	STAGE DOOR						Yes	35Rw							
L2 +42	D.L2.09	L2.AL.02	OPPOSITE PROMPT	DST-01	Double Door	2285	2245	2245	2633	2553	1269	1269	2	120	120.0		WTM-01a</																						







DA0340 SANITARY FIXTURES & FITTINGS SCHEDULE









0999 Sydney Opera House Concert Hall





PREPARED BY: AW & PRB

<i>ISSUE</i>	<i>REVISION</i>	<i>DATE</i>
DA ISSUE	A	27/10/17
DA ISSUE	B	26/04/18
DA ISSUE	C	21/09/18
DA ISSUE	D	5/10/18

Ref. Code	General Description	Detailed / Proprietary Description	Indicative Location	Rev
SANITARY FIXTURES & FITTINGS				
B. BUILDING SERVICES (MECHANICAL, ELECTRICAL & PLUMBING)				
BBN-01	Basin - no taphole	 Caroma Opal 510 no taphole complete with white plug & chrome waste (no overflow) Size: Code: 632600W (9 litre capacity) Shroud Code: 632601W	Ensuite WC's	
BBN-02	Basin	 Caroma Opal 720 wall basin with one taphole, shelf & complete with shroud. Size: Basin Code: 632210W (left hand shelf to suit application) Shroud Code: 632601W	DDA compliant WC's	
BBN-02	Basin	 Caroma Opal 720 wall basin with one taphole, shelf & complete with shroud. Size: Basin Code: 632110W (Right hand shelf to suit application) Shroud Code: 632601W	DDA compliant WC's	
BCS-01	Cleaners Sink	 Caroma Cleaners Sink with rubber rest pad & hinged grating. Size: 575W x 435D Finish: white vitreous china with chrome hinged grating, chrome waste outlet & black rubber rest pad Codes: Sink: 811592W Brackets: 2no x 811594 Grate: 811593 Waste outlet: 687031	Cleaners Store	
BFP-01	Flush Plate	 Caroma Invisi Series II Round Dual Flush Plate and raised life buttons Colour: chrome Code: 237086C	Ensuite WC's DDA compliant WC's	
BFW-01	Floor Waste	 Harbic Halo Trapscrew Floorwaste to suit 100mm pipe Code: HALFWLCF100TCP Finish: satin chrome Size: 115W x 115L x 74D Note: key require for grate removal Key code: HALTSKEY10080	all Shower areas	
BHD-01	Hand Dryer	 Dyson Airbalde V hand dryer Colour: white Code: AB12	Ensuite WC's DDA compliant WC's	
BSB-01	Shower Base	Refer to Detail	Ensuite Showers	
BSB-02	Shower Base DDA	Refer to Detail	DDA compliant showers	

Ref. Code	General Description	Detailed / Proprietary Description	Indicative Location	Rev
BSH-01	Shower Head Kit	 Caroma Urbane Multifunctional Rail Shower With Overhead Chrome Code: 98590C3A	Male Performer Amenities	
BSH-02	Shower - Head Kit	 Caroma Virtu Plus Starsafe Accessible shower ser - inverted T grab rail (select LH/RH to suit) Left Hand: 782740E Right hand: 782741E	DDA compliant WC's	
BTP-01	Tapware	 Caroma Track Wall Basin Mixer Code: 90208C5A	DDA compliant showers Ensuite showers	
BTP-02	Tapware	 Builders Choice Irwell Laundry Set - chrome Code: 830923C4A	Cleaners Store	
BTP-03	Tapware	 Caroma Urbane Bath/Shower mixer Code: 98584C	Ensuite WC's	
BTP-04	Tapware	 Builders Choice Irwell Laundry Set - chrome Code: 830923C4A	Ensuite WC's	
BUR-01	Urinal	 Caroma Cube Invisi Series II Urinal Suite. Code: 771600W	DDA compliant WC's	

Ref. Code	General Description		Detailed / Proprietary Description	Indicative Location	Rev
BWC-01	Pan		Caroma Urbane Cleanflush wallfaced Invisi Series II toilet suite with soft close seat. Code: 746100W	Ensuite WC's	
BWC-02	Pan		Caroma Care 800 Cleanflush wall faced Invisi Series II toilet suite with backrest. Code: 718300SB Seat: Pedigree II care seat single flap care seat - anthracite grey Code: 320030AG	Ensuite WC's DDA compliant WC's	
M. MISCELLANEOUS FIXTURES & FITTINGS (SANITARY)					
MCH-01	Coat Hook		Caroma Urbane Robe Hook Code: 98590C	DDA compliant WC's	
MCU-05	Curtain - shower		Fabric: Bed Bath n Table Stripes shower curtain Track: Alessi Group S/Fold hand operated curtain track surface mounted to ceiling. White powdercoat finish. Refer to RCP for layout.	select BOH ensuites	
MGR-01	Grabrails - fixed		JD MacDonald stainless steel DDA WC sloping arm grabrail Finish: 304 grade stainless steel - linish finish Code: JDM-GFN (select LH or RH to suit application)		
MGR-02	Grabrails - fixed		JD MacDonald stainless steel Changing Places shower grabrail with easy slider & GRSS handle Size O/A: 1000 x 760 x 1100 Finish: 304 grade stainless steel - linish finish Code: GCS34 (select LH or RH to suit application)	DDA compliant showers	
MGR-03	Grabrails - Fold down		JD MacDonald stainless steel drop down toilet grabrail. Adjustable 3 positions. Finish: 304 grade stainless steel - linish finish Code: JDM-GDD (select LH or RH to suit application)	DDA compliant WC's	
MMH-01	Mop & Broom Holder		Bobrick mop & broom holder Size: 915 wide x 85mm deep Finish: 304 grade stainless steel Code: B-223 x 36	Cleaners Store	
MSD-01	Soap Dispenser		Tork Intuition Foam Soap Dispenser Code: 561600	Ensuite WC's DDA compliant WC's	

Ref. Code	General Description		Detailed / Proprietary Description	Indicative Location	Rev
MSH-01	Soap Shelf		Caroma Virtu circuit metal soap shelf. Colour: Chrome Code: 0957c	DDA compliant Showers	
MSE-01	Shower seat		JD MacDonald folding shower seat Size: O/A: 960 x 400 Finish: satin stainless steel with slotted white acrylic deck Code: SS960S	DDA compliant showers	
MSS-01	Shower Screen		Stegbar Frameless shower screen with polaris soft close hinge.	Male performer amenities	
MTR-01	Toilet Roll Dispenser		Tork Twin mid size toilet roll dispenser Code: 557500	Ensuite WC's	
MTR-02	Toilet Roll Dispenser		JD MacDonald Recessed double toilet roll holder with hood Size O/A: 320 x 160 Finish: 304 grade stainless steel bright finish Code: 10-74022-BD	DDA compliant WC's	

BRICK WALL TYPES (W.B1-0-##) **MASONRY BLOCK TYPES (W.M1-0-##)** **CONCRETE WALL TYPES (W.C1-0-##)**

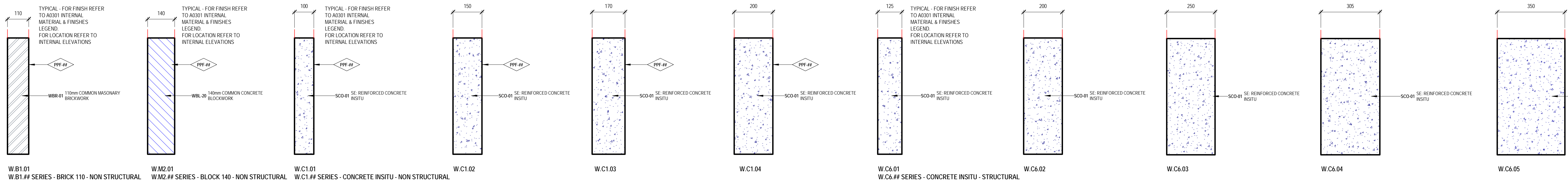

WALL TAG EXAMPLE / EXPLANATION

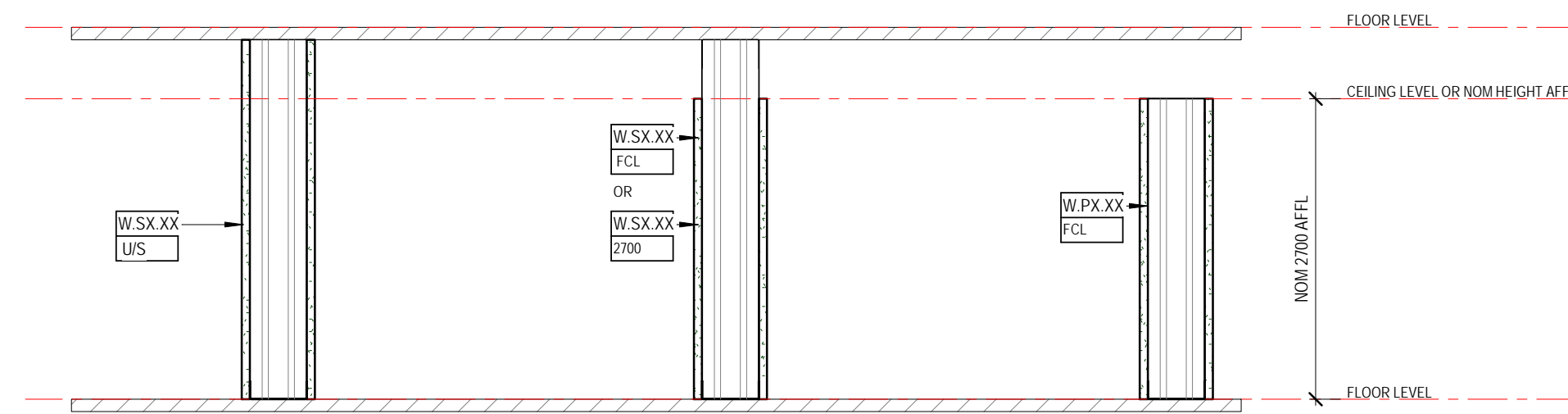

LIGHTWEIGHT STEEL STUD/FRAMED WALL TYPES (W.S1-0-##)

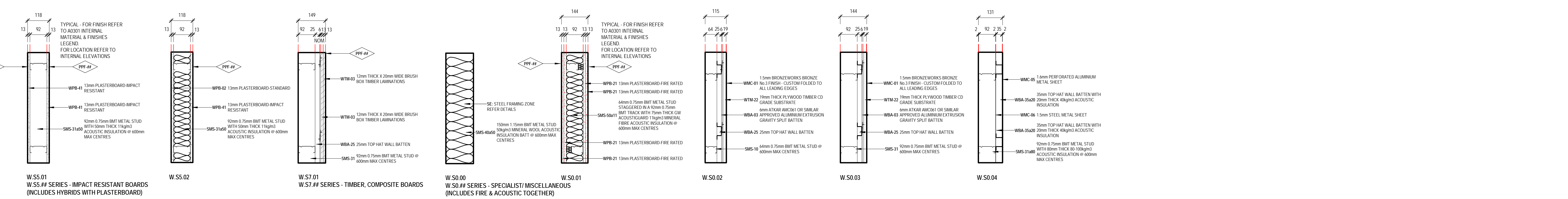
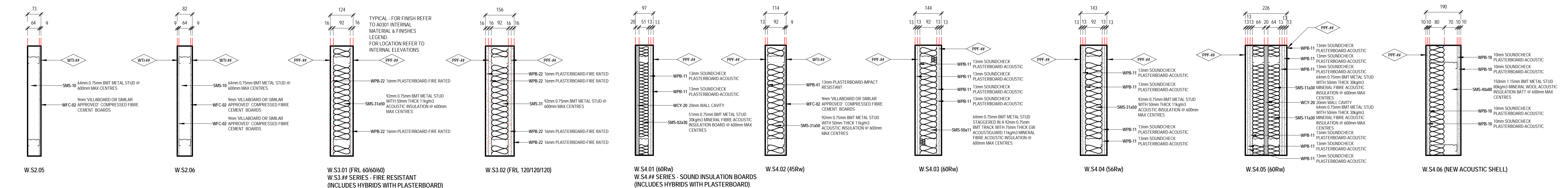
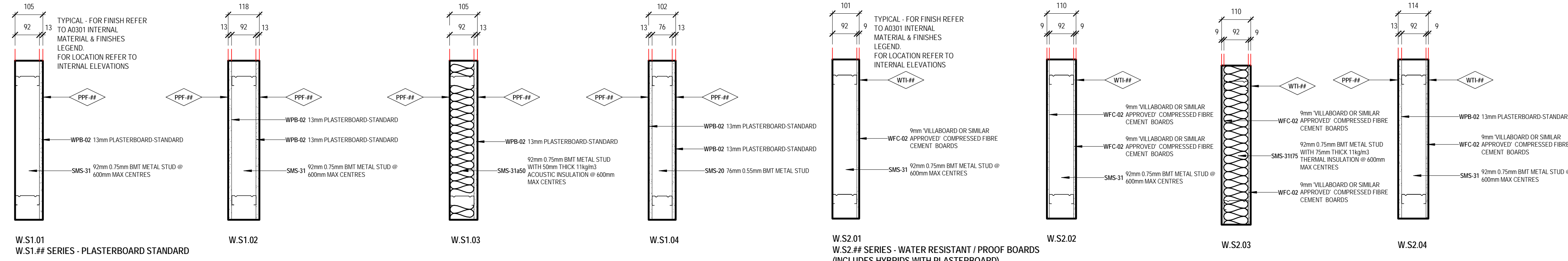

INTERNAL LINING/CLADDING TYPES (W.L1-0-##)

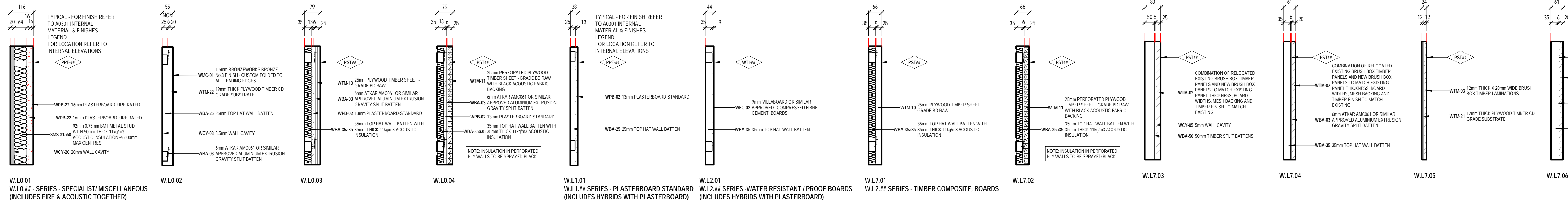

LEGEND - WALL SYSTEM CODES

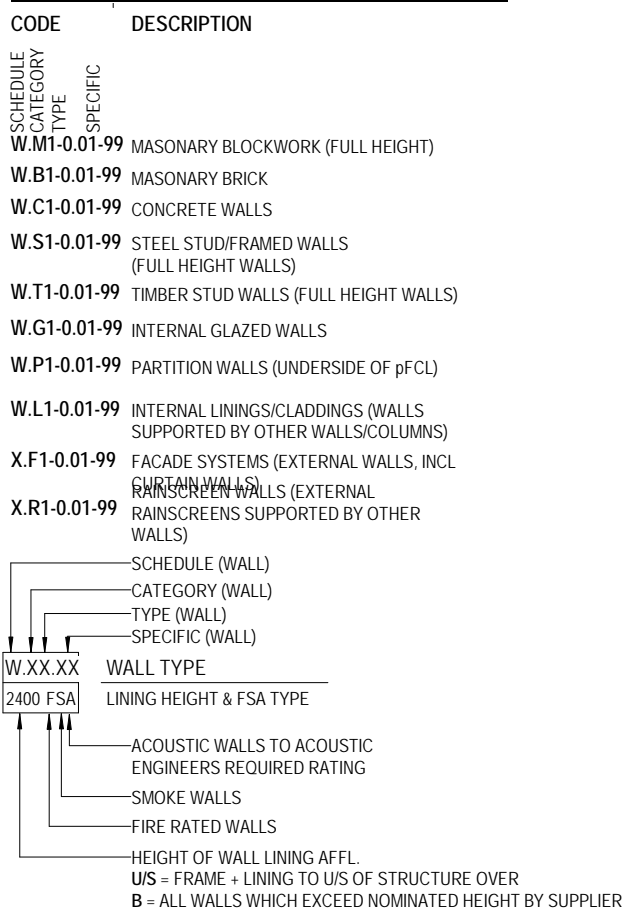

WALL TYPE TAG:

REFER TO DWG A010 FOR DETAILS & DESCRIPTION
NOTE: BMT & SPACING REQUIREMENTS FOR ALL WALL FRAMING TO BE AS PER MANUFACTURERS RECOMMENDATIONS FOR NOMINATED FRAME SIZE & HEIGHT.

FINISHES:

REFER A0301 INTERNAL MATERIALS & FINISHES LEGEND FOR LOCATION REFER TO INTERNAL ELEVATIONS
NOTE: PROVIDE MASTIC SEALS TO SERVICE PENETRATIONS WHERE SERVICES PENETRATE FULL HEIGHT WALLS INTO HABITABLE SPACES

NOTE:

WALLS MARKED 'A' REQUIRE ACOUSTIC INSULATION
NOTE: ALL WALL SETOUT DIMENSIONS ARE TO FACE OF STUDS UNLESS NOTED OTHERWISE.

LEGEND - INTERNAL MATERIALS & FINISHES

REFER TO A0301 INTERNAL MATERIALS & FINISHES SCHEDULE FOR SPECIFIC TYPES & DETAIL ED PROPRIETARY DESCRIPTION

CODE	DESCRIPTION
F	FLOORS/FLOOR COMPONENTS
FAW	ACCESS WALKWAY
FAH	FLOOR ACCESS HATCH
FE	EXISTING FLOOR
FCA	CARPET
FCF	CONCRETE FINISH
FCD	CONCRETE
FCJ	CONTROL JOINT
FEJ	EXPANSION JOINT
FFJ	FALSE JOINT
FLA	FLOOR LADDER
FLB	LEUCOLUM
FPL	PLATE
FSN	STAIR NOSING
FTM	FLOOR TILES
FTB	TIMBER
FTS	TACTILE INDICATORS
FV	VINYL
SC	STRUCTURAL COMPONENTS
SMS	METAL STUDS
SC	CONCRETE
W	WALLS/WALL COMPONENTS
WB	WALL BATTEN
WBL	MASONRY BLOCKWORK
WEX	EXISTING WALL
WFC	COMPRESSED FIBRE CEMENT BOARD
WML	WALL MIRROR
WMC	METAL CLADDING
WPS	WALL PLASTERBOARD
WSK	SKIRTING
WTI	WALL TILES
WTM	TIMBER
WTV	TIMBER VENEER
C	CEILING/CEILING COMPONENTS
CAI	CEILING INSULATION
CEX	EXISTING CEILING/SOFFIT TO REMAIN
CML	METAL CLADDING
CNC	NO CEILING
CPB	PLASTERBOARD
CSU	SUSPENDED CEILING COMPONENTS
CTV	TIMBER VENEER
U	UNDERSE OF EXPOSED CONCRETE SOFFIT
G	GLAZING/GLASS COMPONENTS
GGT	GLASS TYPES
M	MISCELLANEOUS FIXTURES & FITTINGS
MAC	MISCELLANEOUS ACCESSORIES
MBA	BALUSTRADES & SCREENS
MCU	CURTAIN
MFC	FIXED SHELF
MLK	LOCKER
MPI	PICTURE RAIL
MHR	HANDRAIL
B	BUILDING SERVICES (MEP FIXTURES)
BL	LIFT
BFH	FIRE HYDRANT
BFH	FIRE HOSE REEL
P	PAINT APPLIED FINISHES
PF	FIRE RATED INTERSECT PAINT
PPF	PAINT TYPE
PPC	POWDER COAT
PPR	PRIMING PREFIRED WITH SE: REFER TO STRUCTURAL/FACADE ENGINEERS DRAWINGS
PSR	S'ANYTHING PREFIRED WITH ME: REFER TO MECHANICAL ENGINEERS DRAWINGS
ME	'ANYTHING PREFIRED WITH FE: REFER TO FIRE ENGINEERS DRAWINGS
EE:	'ANYTHING PREFIRED WITH EE: REFER TO ELECTRICAL ENGINEERS DRAWINGS
HE:	'ANYTHING PREFIRED WITH HE: REFER TO HYDRAULIC ENGINEERS DRAWINGS
TE:	'ANYTHING PREFIRED WITH TS: REFER TO THEATER CONSULTANTS DRAWINGS

GENERAL NOTES

- CONTRACTOR & SUB-CONTRACTORS TO CO-ORDINATE BETWEEN ARCHITECTURAL STRUCTURAL & SERVICES DOCUMENTATION WITH ARCHITECTURAL DOCUMENTATION TO TAKE PRECEDENT FOR SETOUT.
- CONTRACTOR & SUB-CONTRACTORS TO VERIFY ALL DIMENSIONS & CONFIRM ON SITE CONDITIONS RELATING TO ALL DIMENSIONS PRIOR TO COMMENCEMENT - DO NOT SCALE FROM DRAWING.
- SHOP DRAWINGS ARE TO BE SUPPLIED TO THE RELEVANT PARTIES & CONSULTANTS FOR REVIEW & APPROVAL PRIOR TO THE COMMENCEMENT OF ANY WORKS.
- THIS DRAWING IS TO BE READ IN CONJUNCTION WITH ALL ASSOCIATED SPECIFICATIONS, SCHEDULES & CONTRACT DOCUMENTS.
- MAKE GOOD ALL AFFECTED SURFACES & FINISHES INCLUDING ITEMS MARKED FOR REMOVAL &/OR RELOCATION.
- THE CONTRACTOR IS TO ALLOW TO SAND AND RE-FINISH ALL BRUSHBOX NOMINATED TO BE RE-USED THE WORKS. THIS BRUSHBOX IS TO BE INCORPORATED WHEREVER POSSIBLE WHERE WTM-02 IS NOMINATED.

Date	Description	Drawn	Checked	Date
01/08/2018	01/08/2018			



Legend	Scope
(Green dashed line)	AREA TO BE REMOVED
(Red dashed line)	AREA TO BE ADDED
(Blue dashed line)	AREA TO BE MAINTAINED
(Black dashed line)	AREA TO BE DEMOLISHED
(Green dashed line)	AREA SURROUNDED BY GREEN DASHED LINES DEPICTS TENDER OPTION

SOHT GENERAL NOTES
1. ALL DIMENSIONS AND SIZES ARE IN MILLIMETRES.
2. DO NOT SCALE DRAWINGS. USE FIGURED DIMENSIONS ONLY.
3. INFORMATION INDICATED IN THIS DOCUMENT MAY BE CRUCIAL TO THE SAFE AND PROPER FUNCTIONING OF THE SYDNEY OPERA HOUSE. DO NOT ALTER ANY ASPECT WITHOUT WRITTEN PERMISSION.
4. ALL NEW WORKS MUST COMPLY WITH THE SYDNEY OPERA HOUSE BUILDING SERVICES (STANDARD SPECIFICATION (BS)) AND RELEVANT AUSTRALIAN STANDARDS. NEW WORKS MUST ALSO SO COMPLY WITH THE REQUIREMENTS OF THE BUILDING CODES OF AUSTRALIA.

SOHT COPYRIGHT
THIS DRAWING AND DESIGN ARE SUBJECT TO COPYRIGHT AND SHALL NOT BE COPIED IN ANY FORM WITH THE WRITTEN PERMISSION OF THE SYDNEY OPERA HOUSE TRUST.

Location	North
Location	North

Status	Development Application Issue
Status	Development Application Issue
Contract	BDM-168
Dwn	PRB
Ckd	Art
Date	2/8/2018
Scale	AS SHOWN BY

Project	BUILDING RENOVATION PROJECT - CONCERT HALL
Project	BUILDING RENOVATION PROJECT - CONCERT HALL
Title	WALL TYPES SCHEDULE
Location	49-BR-ARM01
Sheet	D 04010
Rev.	D B1

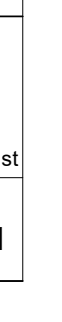

CONCRETE FLOOR TYPES (F.C1-0-##)

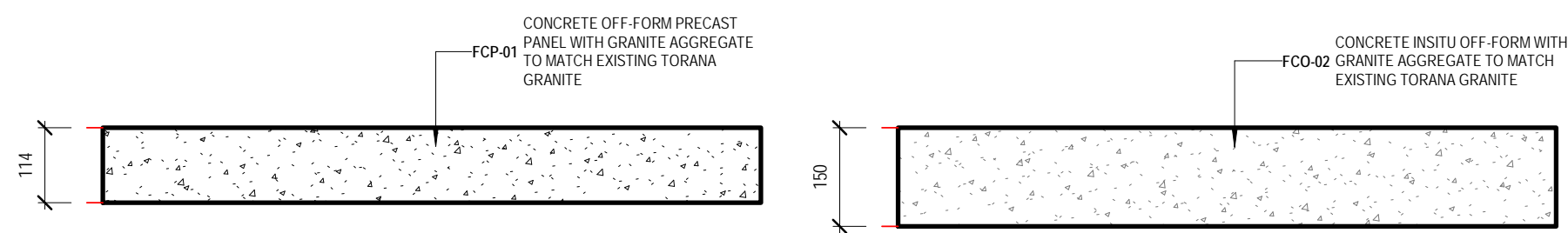

F.C0.01
F.C0.## SERIES - SPECIALIST/MISCELLANEOUS CONCRETE

F.C0.02

FLOOR LINING TYPES (F.L1-0-##)

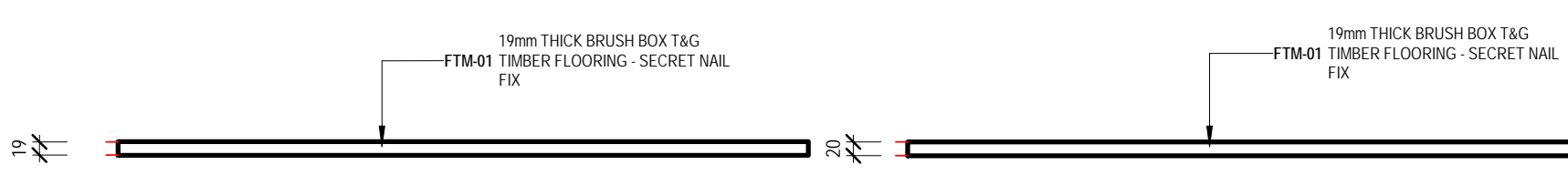

F.L6.01
F.L6.## SERIES - TIMBER
(FLOORBOARDS, PLYWOOD)

F.L6.02

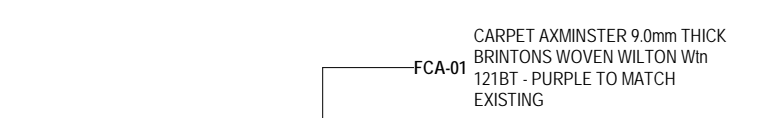

F.L7.01
F.L7.## SERIES - CARPETS
(INCLUDING CARPET TILES)

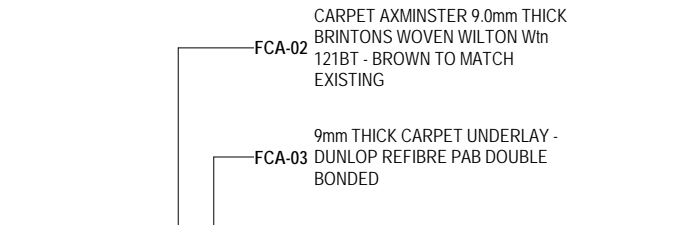

F.L7.02

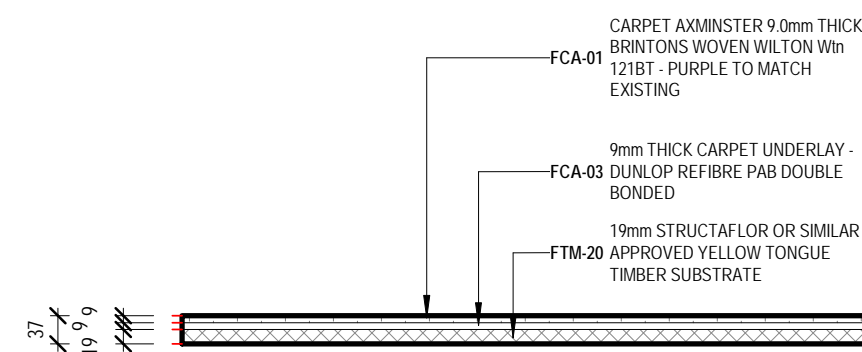

F.L7.03

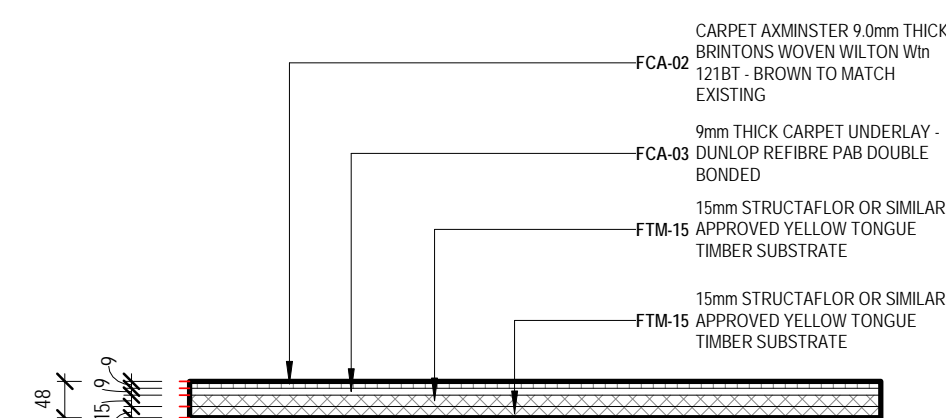

F.L7.04

STEEL FRAMED FLOOR TYPES (F.S0-0-##)

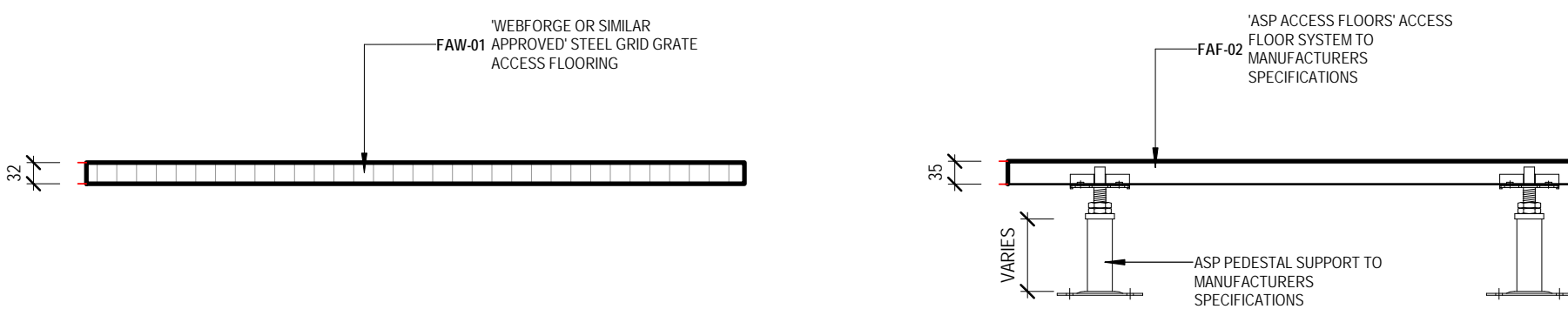

F.S0.01
F.S0.## SERIES - STEEL FRAMED FLOORS

F.S0.02

TIMBER FRAMED FLOOR TYPES (F.T1-0-##)

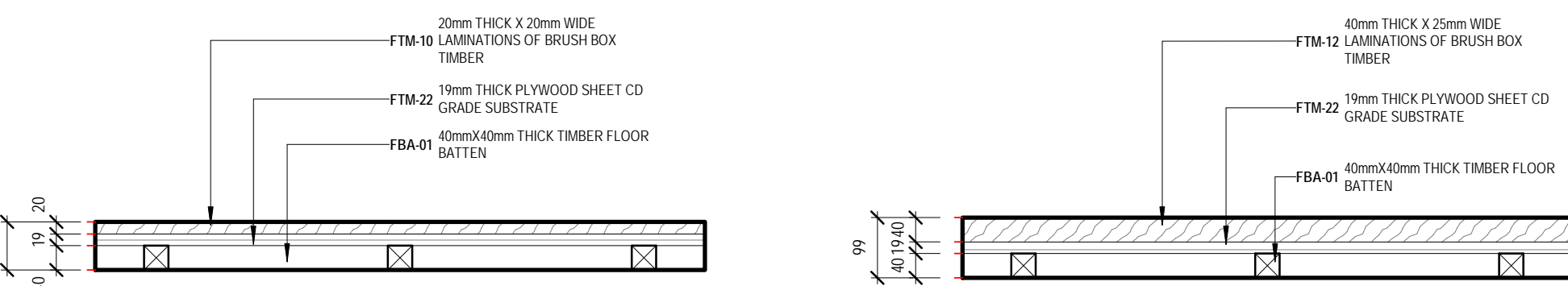

F.T4.01
F.T4.## SERIES - TIMBER
(FLOORBOARDS, PLYWOOD)

F.T4.02

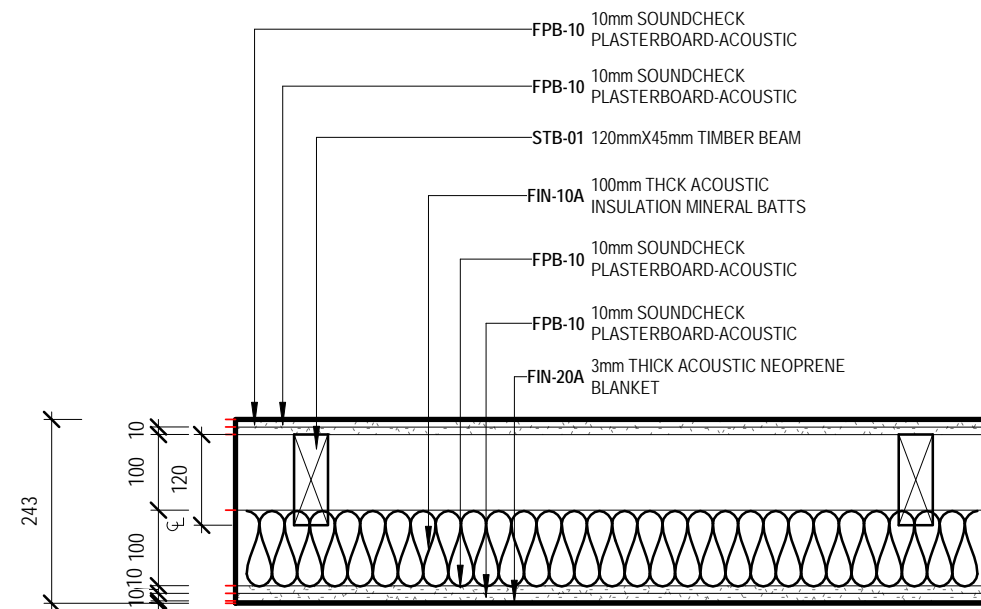

F.T0.01 (NEW ACOUSTIC SHELL)

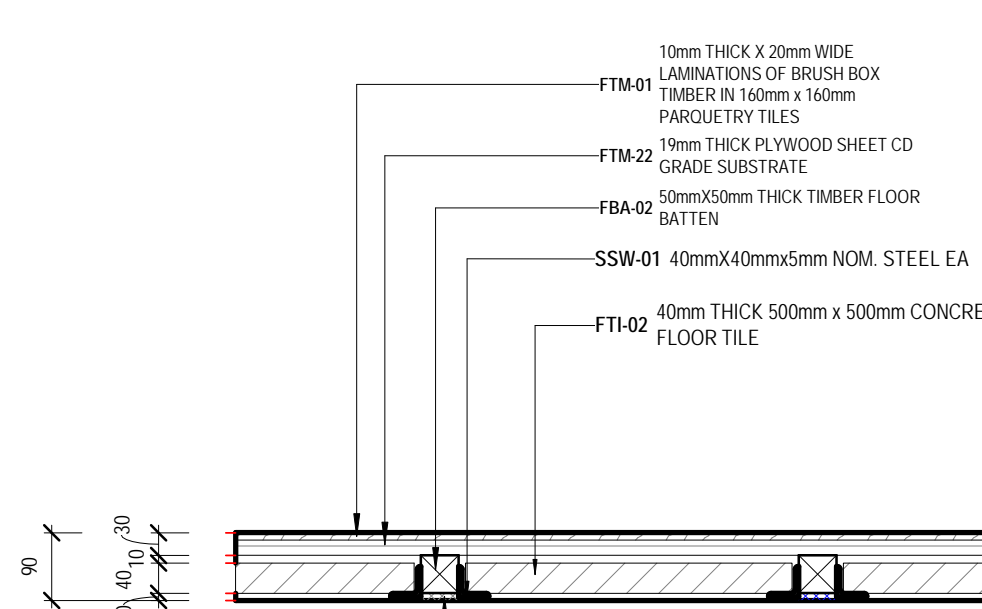

F.T0.02

LEGEND - FLOOR SYSTEM CODES

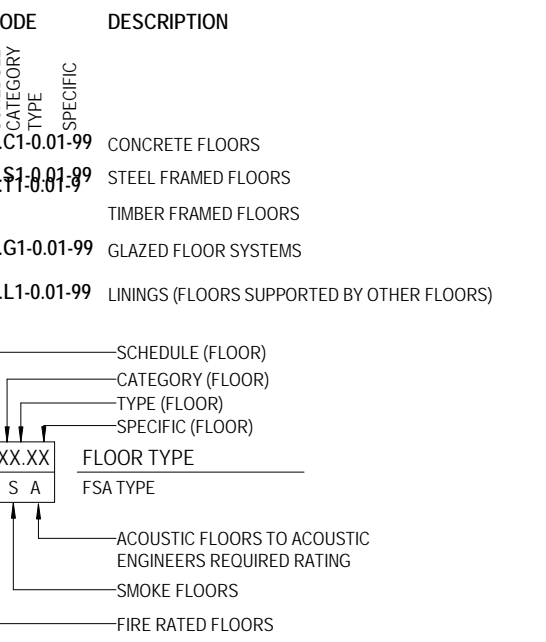

FLOOR TYPE TAG:
REFER TO DWG A0411 FOR DETAILS & DESCRIPTION

LEGEND - INTERNAL MATERIALS & FINISHES

REFER TO A0301 INTERNAL MATERIALS & FINISHES SCHEDULE FOR SPECIFIC TYPES & DETAILED/PROPRIETARY DESCRIPTION

CODE	DESCRIPTION
F	FLOORS/FLOOR COMPONENTS
FAW	ACCESS WALKWAY
FAH	FLOOR ACCESS HATCH
FEK	EXISTING FLOOR
FCA	CARPET
FCF	CONCRETE FINISH
FCO	CONCRETE
FCJ	CONTROL JOINT
FEJ	EXPANSION JOINT
FEJ	FALSE JOINT
FLL	FLOOR LADDER
FLL	LINCE CLIM
FPL	PLATE
FSN	STAR NOSING
FTI	FLOOR TILES
FTM	TIMBER
FTS	TACTILE INDICATORS
FWI	WALL
S	STRUCTURAL COMPONENTS
SMS	METAL STUDS
SCD	SE: CONCRETE
W	WALL/WALL COMPONENTS
WBA	WALL BATTEN
WBL	MASONRY BLOCKWORK
WEX	EXISTING WALL
WFC	COMPRESSED FIBRE CEMENT
WMB	WALL MIRROR
WMC	METAL CLADDING
WPB	WALL PLASTERBOARD
WOK	SKIRTING
WTI	WALL TILES
WTM	TIMBER
WTV	TIMBER VENEER
C	CEILING/CEILING COMPONENTS
CAI	CEILING INSULATION
CEX	EXISTING CEILING/SOFFIT TO REMAIN
CNC	METAL CLADDING
CNC	NO CEILING
CRB	PLASTERBOARD
CSU	SUSPENDED CEILING COMPONENTS
CTV	TIMBER VENEER
US	UNDERSIDE OF EXPOSED CONCRETE SOFFIT
G	GLAZING/GLASS COMPONENTS
GGT	GLASS TYPES
M	MISCELLANEOUS FIXTURES & FITTINGS
MAC	MISCELLANEOUS ACCESSORIES
MBA	BALUSTRADES & SCREENS
MCJ	CURTAIN
MFC	FIXED SHELF
MLK	LOCKER
MPR	PICTURE RAIL
MBR	HANDRAIL
B	BUILDING SERVICES (MEP FIXTURES)
BLI	LIFT
BFH	FIRE HYDRANT
BFR	FIRE HOSE REEL
P	PAINT & APPLIED FINISHES
PFR	FIRE RATED INTUMESCENT PAINT
PFV	PAINT TYPE
PPD	POWDERCOAT
PPR	PROTECTIVE COATING
PSR	SLIP RESISTANT COATING
PST	STAIN SYSTEM

SE: ANYTHING PREFIXED WITH SE: REFER TO STRUCTURAL/FACADE ENGINEERS DRAWINGS
ME: ANYTHING PREFIXED WITH ME: REFER TO MECHANICAL ENGINEERS DRAWINGS
FE: ANYTHING PREFIXED WITH FE: REFER TO FIRE ENGINEERS DRAWINGS
EE: ANYTHING PREFIXED WITH EE: REFER TO ELECTRICAL ENGINEERS DRAWINGS
HE: ANYTHING PREFIXED WITH HE: REFER TO HYDRAULIC ENGINEERS DRAWINGS
TS: ANYTHING PREFIXED WITH TS: REFER TO THEATER CONSULTANTS DRAWINGS

Issue	Description	Drawn	Approved	Date
0	ISSUE			20/10/2018



LEGEND - SCOPE

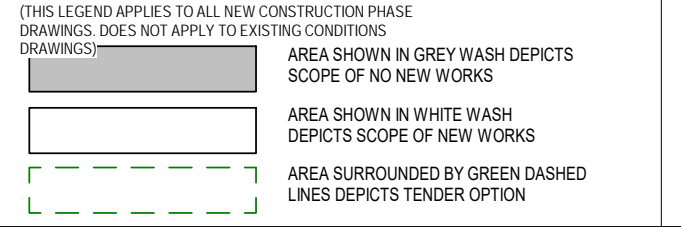

SOHT GENERAL NOTES

- ALL DIMENSIONS AND SIZES ARE IN MILLIMETRES.
- DO NOT SCALE DRAWINGS. USE FIGURED DIMENSIONS ONLY.
- INFORMATION INDICATED IN THIS DOCUMENT MAY BE CRUCIAL TO THE SAFE AND PROPER FUNCTIONING OF THE SYDNEY OPERA HOUSE. DO NOT ALTER ANY ASPECT WITHOUT WRITTEN PERMISSION.
- ALL NEW WORKS MUST COMPLY WITH THE SYDNEY OPERA HOUSE BUILDING SERVICES STANDARD SPECIFICATION (BSSS) AND RELEVANT AUSTRALIAN STANDARDS. NEW WORKS MUST ALSO COMPLY WITH THE REQUIREMENTS OF THE BUILDING CODES OF AUSTRALIA.

SOHT COPYRIGHT

THIS DRAWING AND DESIGN ARE SUBJECT TO COPYRIGHT AND SHALL NOT BE COPIED IN ANY FORM WITH THE WRITTEN PERMISSION OF THE SYDNEY OPERA HOUSE TRUST

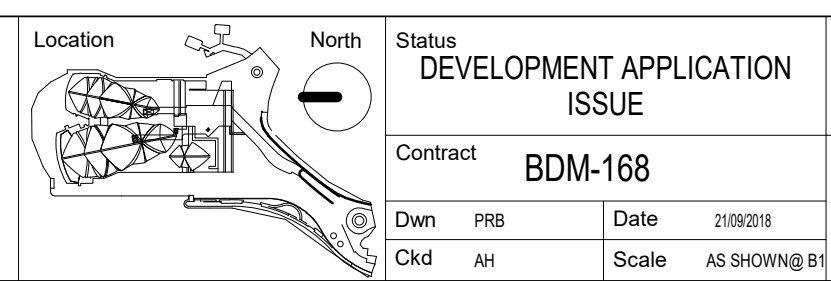

Status	DEVELOPMENT APPLICATION ISSUE
Contract	BDM-168
Dwn	PRB
App	AR
Date	2/10/2018
Scale	A8 SHOWING B1

Project	BUILDING RENEWAL PROJECT - CONCERT HALL
Title	FLOOR TYPES SCHEDULE
Location	CHVA
Drawing No.	49-BR-ARM01
Sheet	DA0411
Rev.	D
	B1



LEGEND - CEILING SYSTEM CODES

CODE	DESCRIPTION
C.H1.01-99	HANGING - SUSPENDED CEILING
C.S1.01-99	STEEL FRAMED CEILING
C.T1.01-99	TIMBER FRAMED CEILING
C.G1.01-99	GLAZED CEILING SYSTEMS
C.L1.01-99	LININGS (CEILING SUPPORTED BY OTHER CEILING)

SCHEDULE (CEILING)	CATEGORY (CEILING)	TYPE (CEILING)	SPECIFIC (CEILING)	CEILING TYPE	FSA TYPE
C.XXX.XX					
F	S	A			

ACUSTIC CEILING TO ACUSTIC ENGINEERS REQUIRED RATING	SMOKE CEILING	FIRE RATED CEILING

CEILING TYPE TAG:
REFER TO DWG AD12 FOR DETAILS & DESCRIPTION
NOTE: CEILINGSS MARKED 'A' REQUIRING ACUSTIC INSULATION ADDITIONAL TO DOCUMENTED EXTENT TO BE CONFIRMED BY ACUSTIC ENGINEER

LEGEND - CEILING MATERIAL TYPES
 REFER TO A001 INTERNAL MATERIALS & FINISHES SCHEDULE FOR SPECIFIC TYPES & DETAILED/PROPRIETARY DESCRIPTION

INSULATION	EXISTING CEILING/SOFFIT TO REMAIN
METAL CLADDING	NO CEILING
PLASTERBOARD	TIMBER VENEER
PAINT & APPLIED COATING TYPES	US OF EXPOSED CONCRETE SOFFIT
ANYTHING PREFIXED WITH 'E' DENOTES EXISTING	CONFIRM ON SITE TO BE CONFIRMED
REDUCED OR RELATIVE LEVEL	ABOVE FINISHED FLOOR LEVEL
EXISTING FINISHED CEILING LEVEL	FINISHED CEILING LEVEL
EXISTING RETAINED ARCHITECTURAL ELEMENT TO BE RE-INSTATED TO ORIGINAL SITE CONDITIONS	ANYTHING PREFIXED WITH 'SE' REFER TO STRUCTURAL ENGINEERS DRAWINGS
ANYTHING PREFIXED WITH 'ME' REFER TO MECHANICAL ENGINEERS DRAWINGS	ANYTHING PREFIXED WITH 'EE' REFER TO ELECTRICAL ENGINEERS DRAWINGS
ANYTHING PREFIXED WITH 'HE' REFER TO HYDRAULIC ENGINEERS DRAWINGS	ANYTHING PREFIXED WITH 'TS' REFER TO THEATER SPECIALISTS DRAWINGS

LEGEND - CEILING FIXTURES & FITTINGS
 FOR MECHANICAL LEGEND REFER TO A001 FOR FIRE PROTECTION SERVICES LEGEND REFER TO F001 FOR ELECTRICAL SERVICES LEGEND REFER TO E001 FOR THEATER SPECIALIST LEGEND REFER TO T001 *SPECIALIST LIGHTING TO BE CONFIRMED IN SCOPE *ALL FINAL LOCATION TO BE COORDINATED WITH SERVICES DRAWINGS *EXISTING FIXTURE & FITTING LOCATION TO BE C.O.S. SMOKE DETECTOR
 EXIT SIGN INCLUDING LED LIGHT
 WALL MOUNTED EXIT SIGN INCLUDING LED LIGHT WITH DIRECTIONAL ARROW
 EMERGENCY LIGHTING
 SECURITY CAMERA
 SPRINKLERS
 FIRE HYDRANT POINT
 FIRE HOSE REEL
 WALL MOUNT OCCUPANCY SENSOR
 CEILING MOUNT OCCUPANCY SENSOR
 DOWNLIGHT
 PL PENDANT LINEAR LIGHT - LED
 FLUORESCENT LIGHT FIXTURE
 PC PEOPLE COUNTER
 CAH CEILING ACCESS HATCH
 SPEAKER
 VISUAL ALARM DEVICE
 RIGGING POINT
 CEILING MOUNTED RETURN, EXHAUST OR TRANSFER GRILLE
 CEILING MOUNTED SUPPLY AIR DIFFUSER
 AIR GRILLE

NOTE: LIGHTING SPECIFICATION REFER ELECTRICAL DRAWINGS, SPECIFICATION & LUMINAIRE SCHEDULE.

GENERAL NOTES

- CONTRACTOR & SUB-CONTRACTORS TO CO-ORDINATE BETWEEN ARCHITECTURAL, STRUCTURAL & SERVICES DOCUMENTATION WITH ARCHITECTURAL DOCUMENTATION TO TAKE PRECEDENT FOR SETOUT.
- CONTRACTOR & SUB-CONTRACTORS TO VERIFY ALL DIMENSIONS & CONFIRM ON SITE CONDITIONS RELATING TO ALL DIMENSIONS PRIOR TO COMMENCEMENT - DO NOT SCALE FROM DRAWING
- SHOP DRAWINGS ARE TO BE SUPPLIED TO THE RELEVANT PARTIES & CONSULTANTS FOR REVIEW & APPROVAL PRIOR TO THE COMMENCEMENT OF ANY WORKS
- THIS DRAWING IS TO BE READ IN CONJUNCTION WITH ALL ASSOCIATED SPECIFICATIONS, SCHEDULES & CONTRACT DOCUMENTS
- MAKE GOOD ALL AFFECTED SURFACES & FINISHES INCLUDING ITEMS MARKED FOR REMOVAL &/OR RELOCATION
- THE CONTRACTOR IS TO ALLOW TO SAND AND RE-FINISH ALL BRUSHBOX NOMINATED TO BE RE-USED THE WORKS. THIS BRUSHBOX IS TO BE INCORPORATED WHEREVER POSSIBLE WHERE WTM-02 IS NOMINATED

HANGING - SUSPENDED CEILING TYPES (C.H1-0-##)

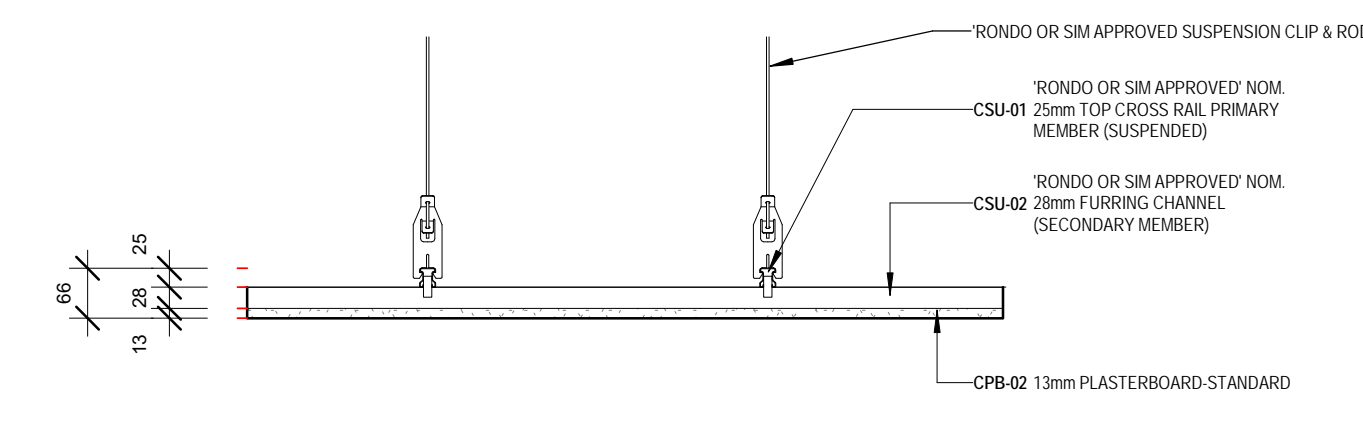

C.H1.01
 C.H1.# SERIES - PLASTERBOARD STANDARD

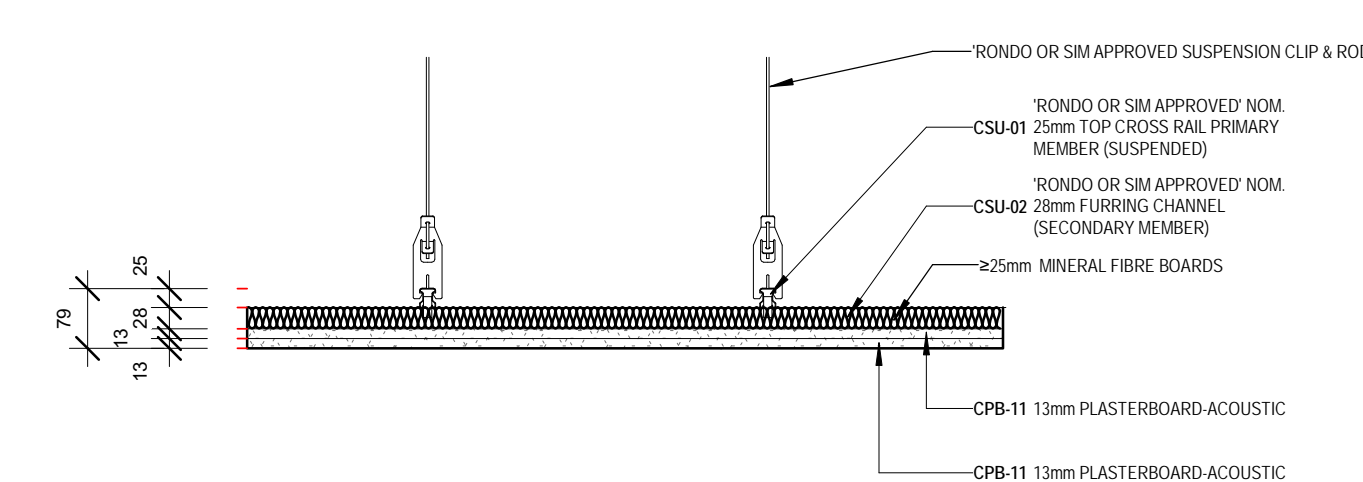

C.H4.01
 C.H4.# SERIES - SOUND INSULATION BOARDS (INCLUDES HYBRIDS WITH PLASTERBOARD)

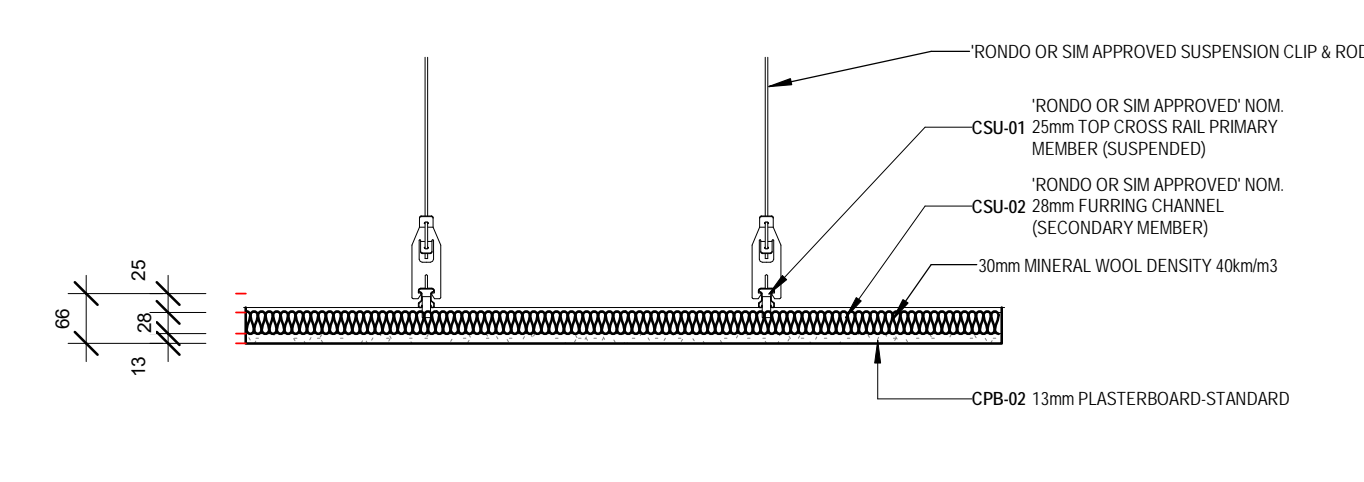

C.H4.02

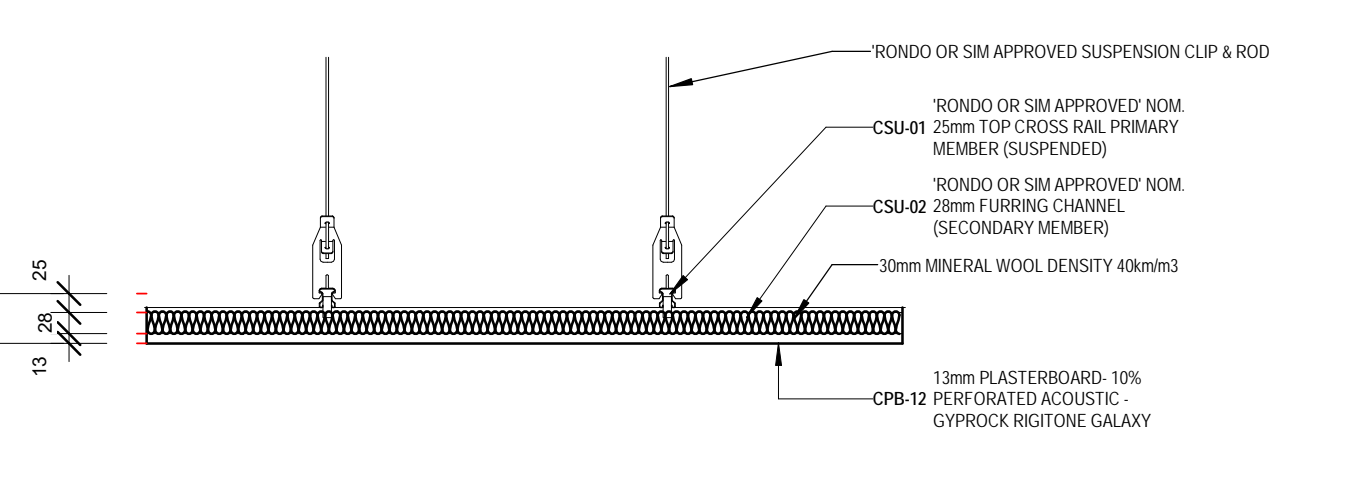

C.H4.03

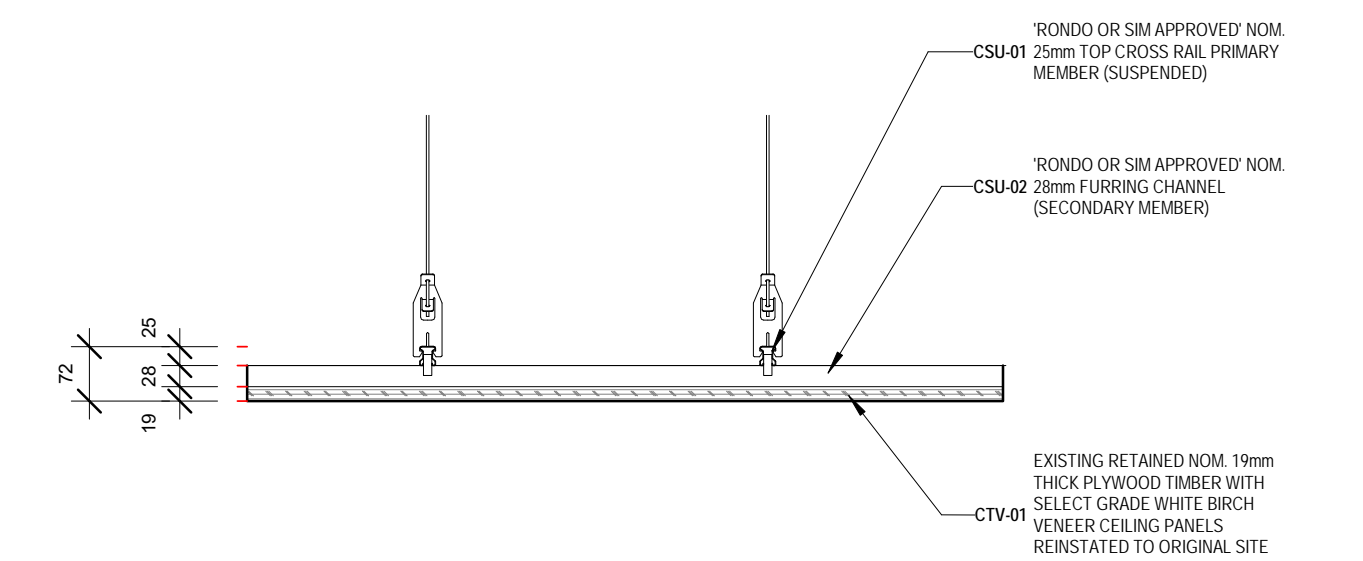

C.H6.01
 C.H6.# SERIES - TIMBER COMPOSITE BOARDS (INCLUDES PLYWOOD, MDF, STRAWBOARD)

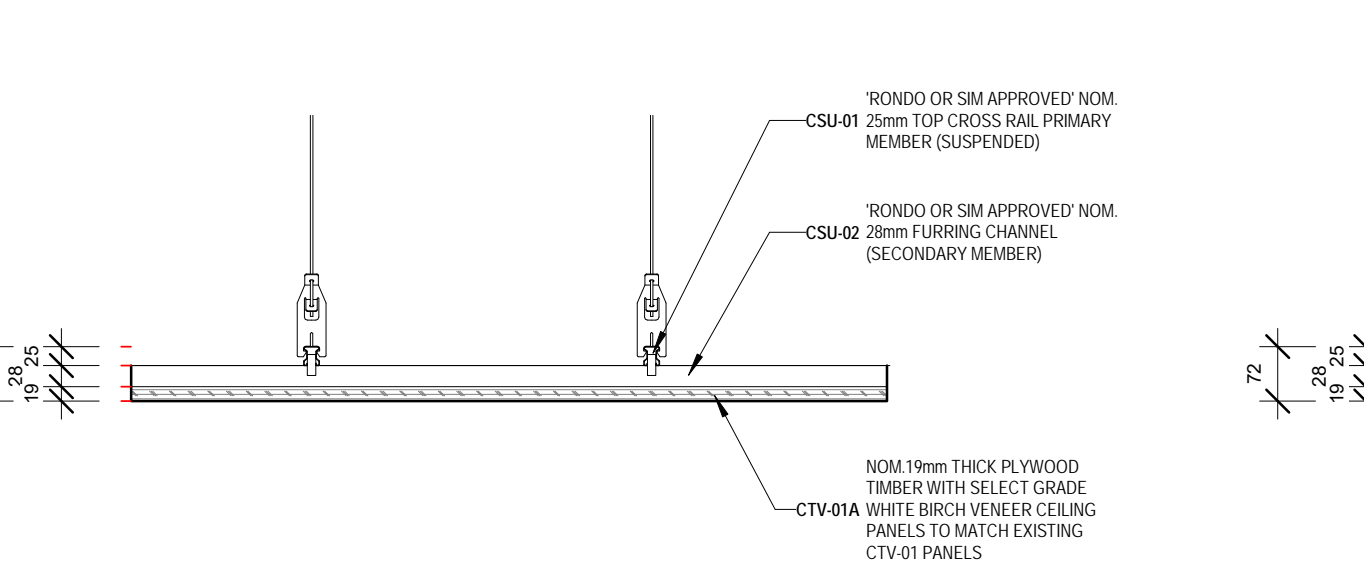

C.H6.02

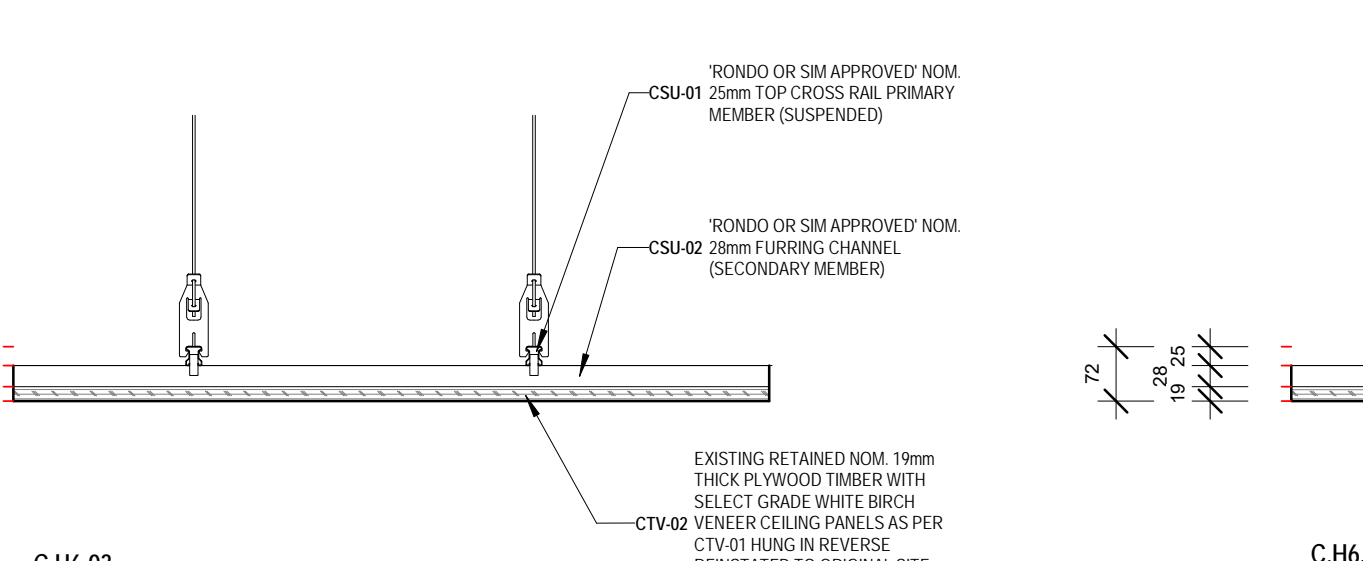

C.H6.03

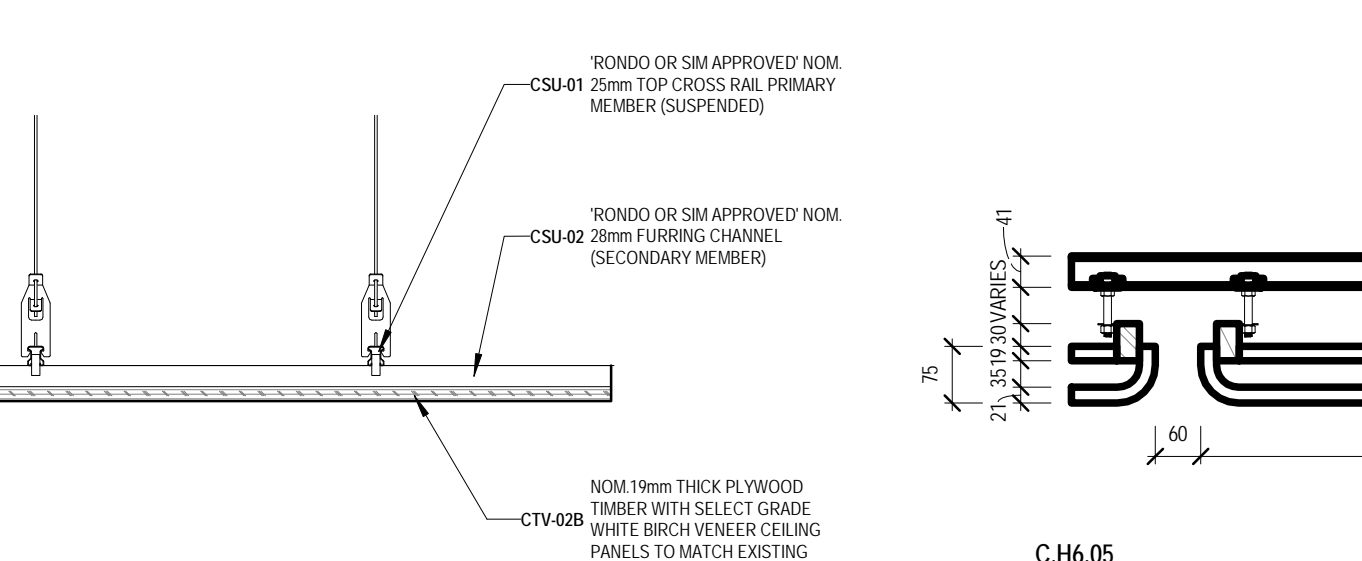

C.H6.04

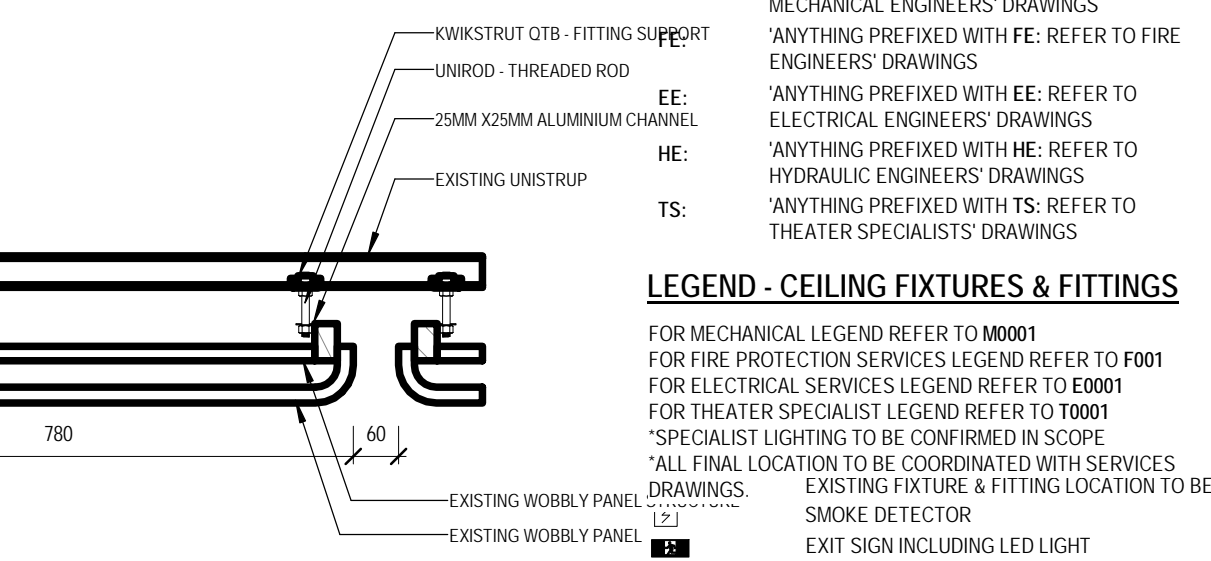

C.H6.05

STEEL FRAMED CEILING TYPES (C.S1-0-##)

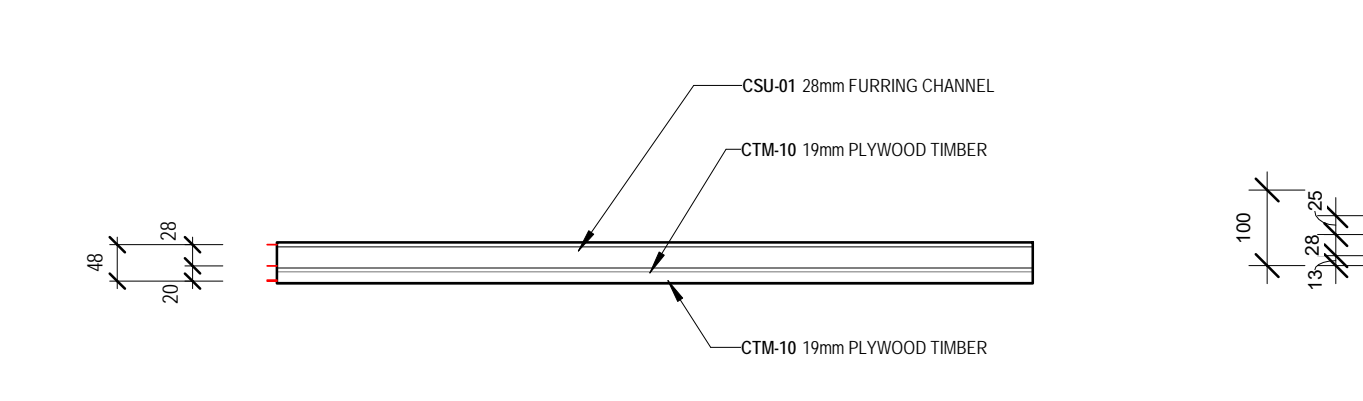

C.S0.01
 C.S0.# SERIES - SPECIALIST / MISCELLANEOUS

TIMBER FRAMED CEILING TYPES (C.T1-0-##)

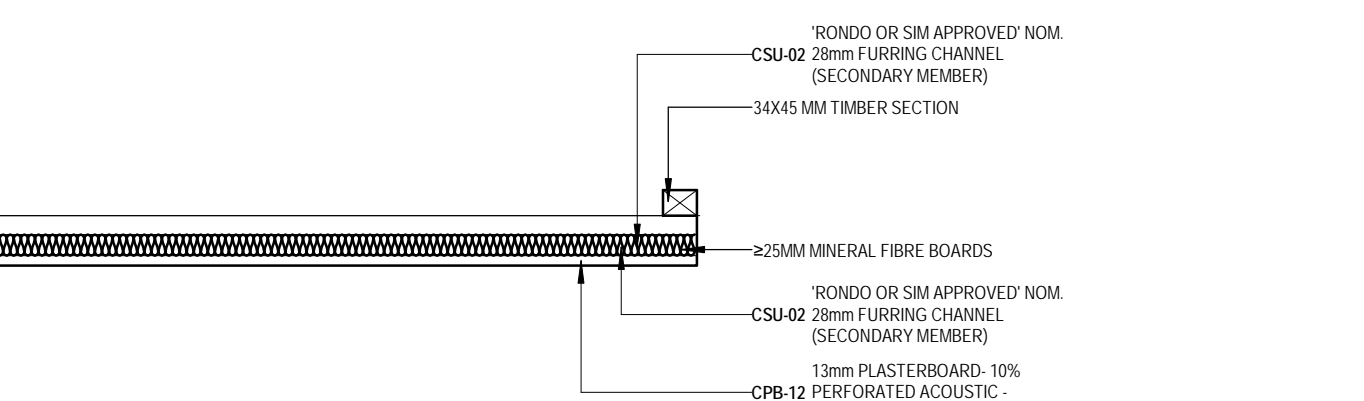

C.T4.01
 C.T4.# SERIES - SOUND INSULATION BOARDS (INCLUDES HYBRIDS WITH PLASTERBOARD)

Issue	Description	Dwn	Appd	Date
0	ISSUANCE			20/10/2018

ARM ARCHITECTURE
 LEVEL 11/222 RUNDENS LANE MELBOURNE VICTORIA 3000 AUS
 T 03 8613 1888 F 03 8613 1889
 mail@armarchitecture.com.au
 ABN 72 475 942 299
 www.armarchitecture.com.au

LEGEND - SCOPE
 THIS LEGEND APPLIES TO ALL NEW CONSTRUCTION PHASE DRAWINGS. DOES NOT APPLY TO EXISTING CONDITIONS.

(Grey Wash)	AREA SHOWN IN GREY WASH DEPICTS SCOPE OF NEW WORKS
(White Wash)	AREA SHOWN IN WHITE WASH DEPICTS SCOPE OF NEW WORKS
(Green Dashed)	AREA SURROUNDED BY GREEN DASHED LINES DEPICTS TENDER OPTION

SOHT GENERAL NOTES
 1. ALL DIMENSIONS AND SIZES ARE IN MILLIMETRES.
 2. DO NOT SCALE DRAWINGS. USE FIGURED DIMENSIONS ONLY.
 3. INFORMATION INDICATED IN THIS DOCUMENT MAY BE CRUCIAL TO THE SAFE AND PROPER FUNCTIONING OF THE SYDNEY OPERA HOUSE. DO NOT ALTER ANY ASPECT WITHOUT WRITTEN PERMISSION.
 4. ALL NEW WORKS MUST COMPLY WITH THE SYDNEY OPERA HOUSE BUILDING SERVICES STANDARD SPECIFICATION (BSST) AND RELEVANT AUSTRALIAN STANDARDS. NEW WORKS MUST ALSO COMPLY WITH THE REQUIREMENTS OF THE BUILDING CODES OF AUSTRALIA.

SOHT COPYRIGHT
 THIS DRAWING AND DESIGN ARE SUBJECT TO COPYRIGHT AND SHALL NOT BE COPIED IN ANY FORM WITH THE WRITTEN PERMISSION OF THE SYDNEY OPERA HOUSE TRUST

Location	North

Status	DEVELOPMENT APPLICATION ISSUE
Contract	BDM-168
Dwn	PRB
Date	2/10/2018
Ckd	AR
Scale	AS SHOWN BY

Project	BUILDING RENEWAL PROJECT - CONCERT HALL
Title	CEILING TYPES SCHEDULE

Location	Drawing No:	Sheet:	Rev:
CHVA	49-BR-ARM01	DA0412	D B1

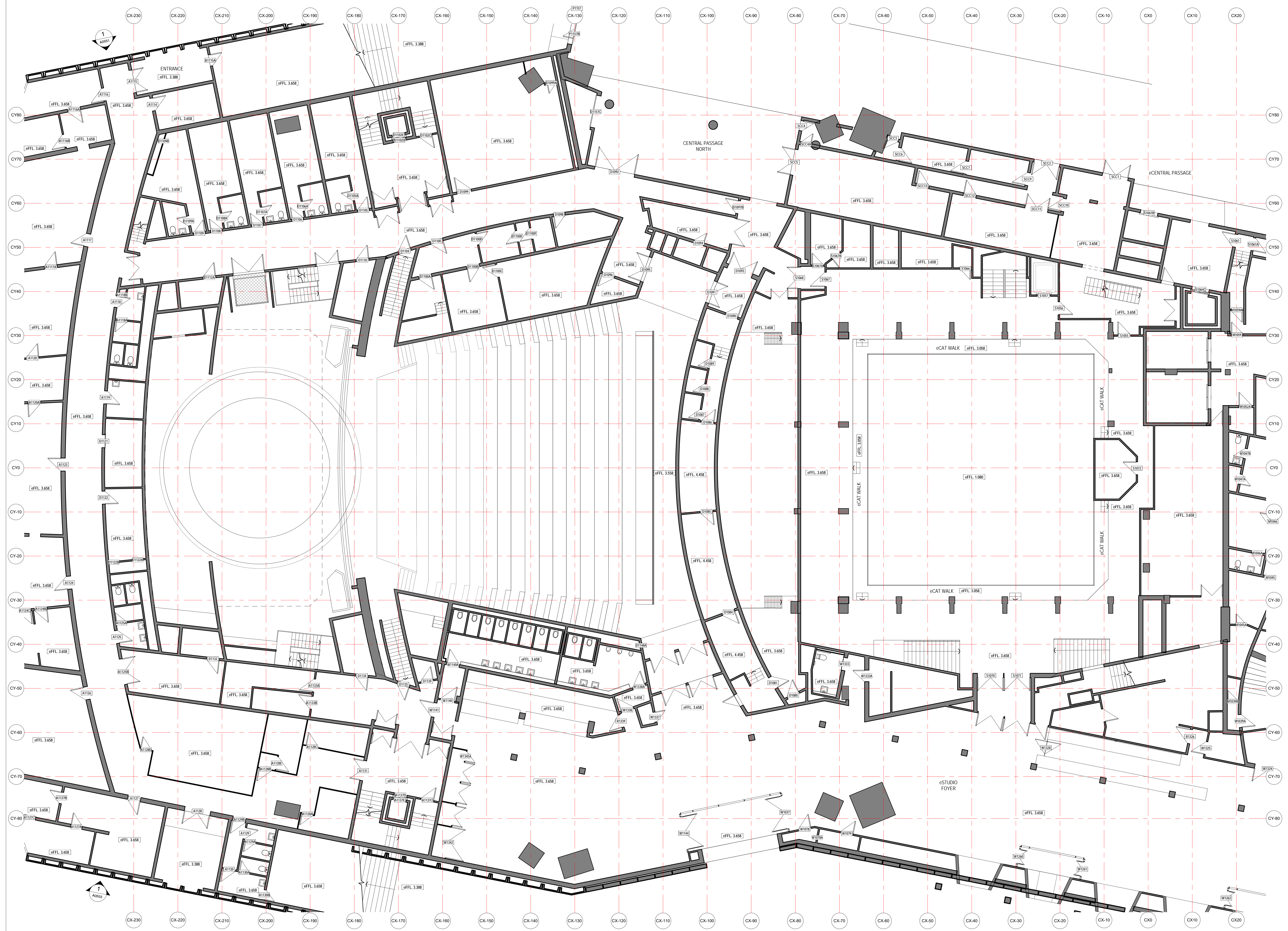

LEGEND - EXISTING CONDITIONS

CODE	DESCRIPTION
—	EXISTING WALL
—	EXISTING FLOOR
—	EXISTING STEEL TRUSS
—	EXISTING DOOR
e	EXISTING
RL	'ANYTHING PREFIXED WITH THE DENOTES REDUCED OR RELATIVE LEVEL
eSSL 3700	EXISTING STRUCTURAL SLAB LEVEL
eFFL 3700	EXISTING FINISHED FLOOR LEVEL

Issue	Description	Dwn	Appd	Date
0	ISSUE			09/10/2018

ARM ARCHITECTURE
 LEVEL 11/522 RIVERSIDE LANE MELBOURNE VICTORIA 3000 AUS
 T 03 8613 1888 F 03 8613 1889
 mail@armarchitecture.com.au
 400 22 476 949 200
 www.armarchitecture.com.au

LEGEND - SCOPE
(THIS LEGEND APPLIES TO ALL NEW CONSTRUCTION PHASE DRAWINGS. DOES NOT APPLY TO EXISTING CONDITIONS)

—	AREA SHOWN IN GREY WASH DEPICTS SCOPE OF NEW WORKS
—	AREA SHOWN IN WHITE WASH DEPICTS SCOPE OF NEW WORKS
—	AREA SURROUNDED BY GREEN DASHED LINES DEPICTS TENDER OPTION

SOHT GENERAL NOTES

- ALL DIMENSIONS AND SIZES ARE IN MILLIMETRES.
- DO NOT SCALE DRAWINGS. USE FIGURED DIMENSIONS ONLY.
- INFORMATION INDICATED IN THIS DOCUMENT MAY BE CRITICAL TO THE SAFE AND PROPER FUNCTIONING OF THE SYDNEY OPERA HOUSE. DO NOT ALTER ANY ASPECT WITHOUT WRITTEN PERMISSION.
- ALL NEW WORKS MUST COMPLY WITH THE SYDNEY OPERA HOUSE BUILDING SERVICES STANDARD SPECIFICATION (BSSS) AND RELEVANT AUSTRALIAN STANDARDS. NEW WORKS MUST ALSO COMPLY WITH THE REQUIREMENTS OF THE BUILDING CODES OF AUSTRALIA.

SOHT COPYRIGHT
 THIS DRAWING AND DESIGN ARE SUBJECT TO COPYRIGHT AND SHALL NOT BE COPIED IN ANY FORM WITH THE WRITTEN PERMISSION OF THE SYDNEY OPERA HOUSE TRUST

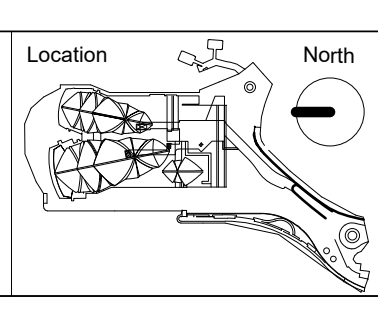

DEVELOPMENT APPLICATION ISSUE

Contract	BDM-168
Dwn	PRB
Date	2/10/2018
Ckd	AM
Scale	1:100@81

Project BUILDING RENEWAL PROJECT - CONCERT HALL

Title	EXISTING CONDITIONS FLOOR PLAN - GROUND LEVEL +12
Location	CHVA
Drawing No.	49-BR-ARM01
Sheet	DA0503
Rev.	D B1

Sydney Opera House Trust
 GPO Box 4274 Sydney NSW Australia 2001
 Phone: +61 2 9250 7541
 email: info@sydneyoperahouse.com

© Sydney Opera House Trust

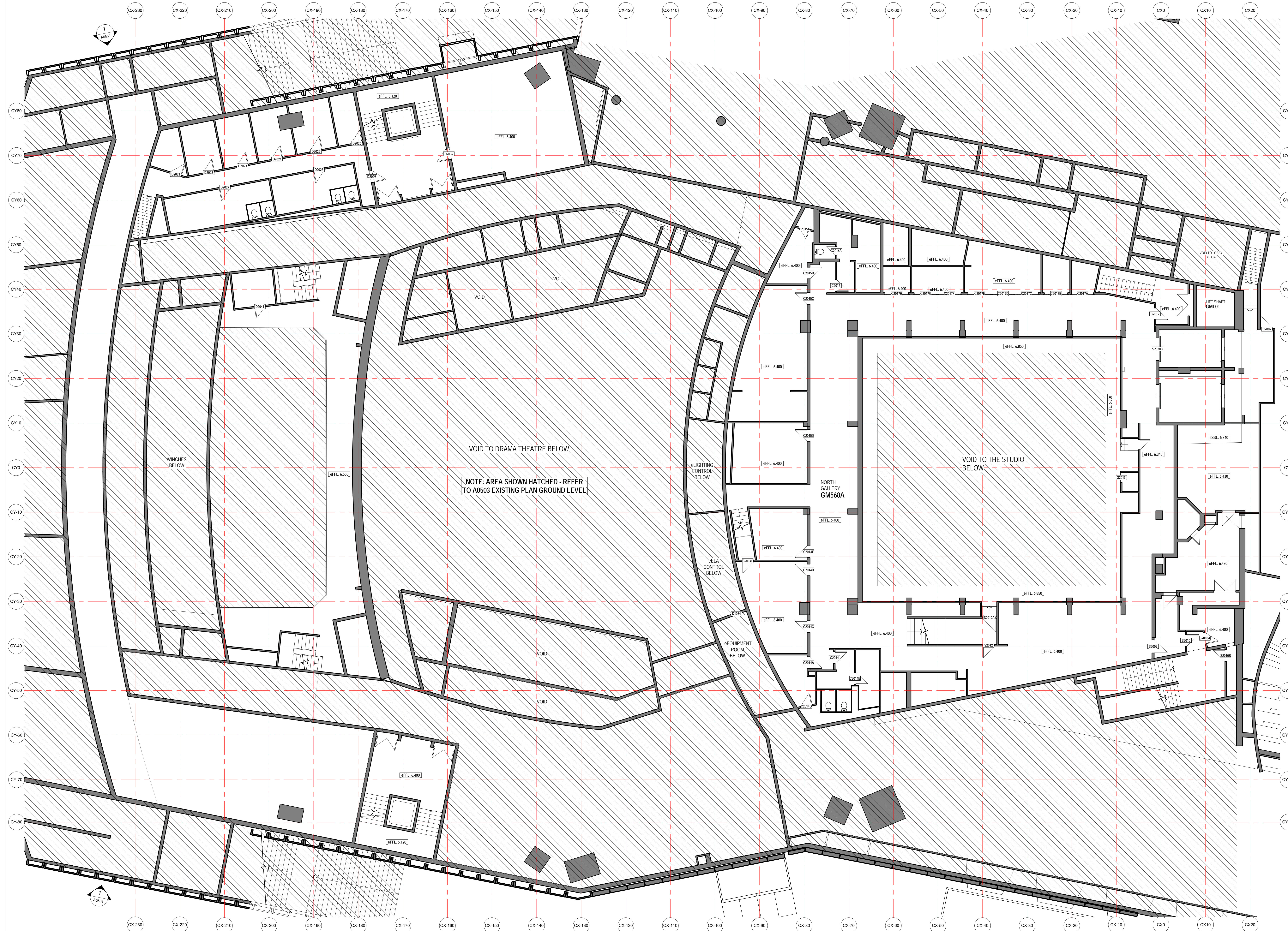

LEGEND - EXISTING CONDITIONS

CODE	DESCRIPTION
EXISTING WALL	EXISTING WALL
EXISTING FLOOR	EXISTING FLOOR
EXISTING STEEL TRUSS	EXISTING STEEL TRUSS
EXISTING DOOR	EXISTING DOOR
e	ANYTHING PREFIXED WITH e DENOTES EXISTING OR RELATIVE LEVEL
RL	EXISTING REDUCED OR RELATIVE LEVEL
[eSSL 3.700]	EXISTING STRUCTURAL SLAB LEVEL
[eFFL 3.700]	EXISTING FINISHED FLOOR LEVEL

VOID TO DRAMA THEATRE BELOW

NOTE: AREA SHOWN HATCHED - REFER TO A0503 EXISTING PLAN GROUND LEVEL

VOID TO THE STUDIO BELOW

NORTH GALLERY GM568A

EQUIPMENT ROOM BELOW

Issue	Description	Dwn	App'd	Date
0	ISSUE			20/10/2018

ARM
ARCHITECTURE
LEVEL 11/522 RINDERS LANE MELBOURNE VICTORIA 3000 AUS
T 03 8613 1888 F 03 8613 1889
mail@armarchitecture.com.au
400 2 475 942 330
www.armarchitecture.com.au

LEGEND - SCOPE
THIS LEGEND APPLIES TO ALL NEW CONSTRUCTION PHASE DRAWINGS. DOES NOT APPLY TO EXISTING CONDITIONS.

[Grey Wash]	AREA SHOWN IN GREY WASH DEPICTS SCOPE OF NEW WORKS
[White Wash]	AREA SHOWN IN WHITE WASH DEPICTS SCOPE OF NEW WORKS
[Green Dashed]	AREA SURROUNDED BY GREEN DASHED LINES DEPICTS TENDER OPTION

- SOHT GENERAL NOTES**
1. ALL DIMENSIONS AND SIZES ARE IN MILLIMETRES.
 2. DO NOT SCALE DRAWINGS. USE FIGURED DIMENSIONS ONLY.
 3. INFORMATION INDICATED IN THIS DOCUMENT MAY BE CRUCIAL TO THE SAFE AND PROPER FUNCTIONING OF THE SYDNEY OPERA HOUSE. DO NOT ALTER ANY ASPECT WITHOUT WRITTEN PERMISSION.
 4. ALL NEW WORKS MUST COMPLY WITH THE SYDNEY OPERA HOUSE BUILDING SERVICES STANDARD SPECIFICATION (BSSS) AND RELEVANT AUSTRALIAN STANDARDS. NEW WORKS MUST ALSO COMPLY WITH THE REQUIREMENTS OF THE BUILDING CODES OF AUSTRALIA.

SOHT COPYRIGHT
THIS DRAWING AND DESIGN ARE SUBJECT TO COPYRIGHT AND SHALL NOT BE COPIED IN ANY FORM WITH THE WRITTEN PERMISSION OF THE SYDNEY OPERA HOUSE TRUST

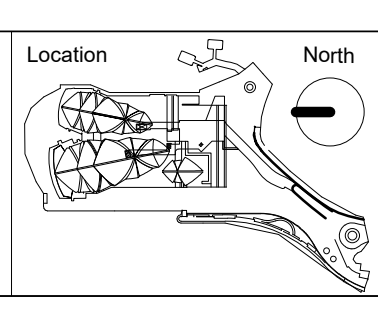

DEVELOPMENT APPLICATION ISSUE

Contract	BDM-168
Dwn	PRB
App'd	AM
Date	2/10/2018
Scale	1:100 @ B1

Project BUILDING RENEWAL PROJECT - CONCERT HALL

Title EXISTING CONDITIONS FLOOR PLAN - GROUND MEZZANINE LEVEL +21

Location	CHVA	Drawing No.	49-BR-ARM01	Sheet	DA0504	Rev.	D B1
----------	------	-------------	-------------	-------	--------	------	------

Sydney Opera House Trust
GPO Box 4274 Sydney NSW Australia 2001
Phone: +61 2 9250 7541
email: info@sydneyoperahouse.com

© Sydney Opera House Trust

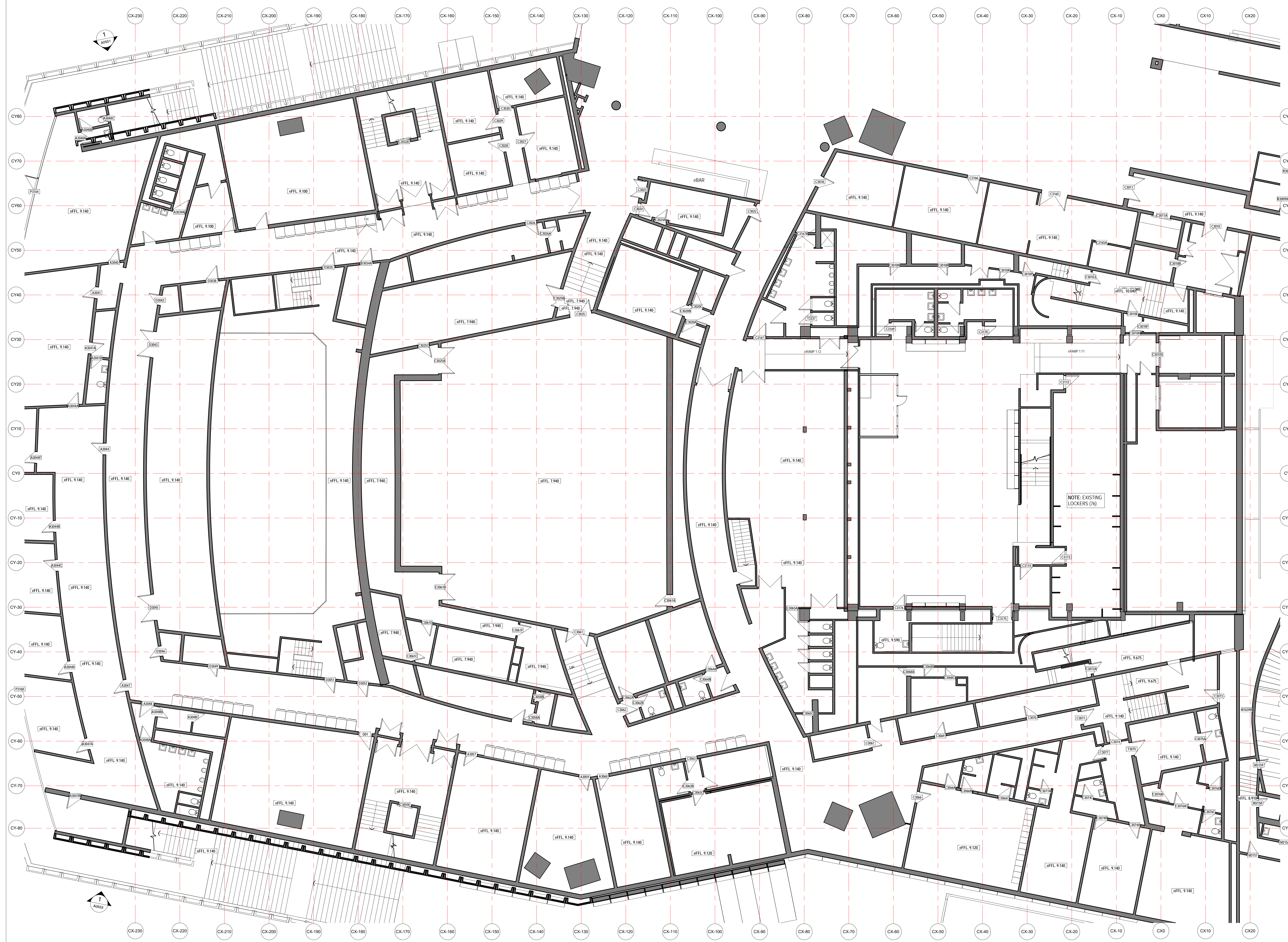

LEGEND - EXISTING CONDITIONS

CODE	DESCRIPTION
EXISTING WALL	EXISTING WALL
EXISTING FLOOR	EXISTING FLOOR
EXISTING STEEL TRUSS	EXISTING STEEL TRUSS
EXISTING DOOR	EXISTING DOOR
e	ANYTHING PREFIXED WITH e DENOTES EXISTING
RL	REDUCED OR RELATIVE LEVEL
eSSL 3700	EXISTING STRUCTURAL SLAB LEVEL
eFFL 3700	EXISTING FINISHED FLOOR LEVEL

NOTE: EXISTING LOCKERS (76)

Issue	Description	Dwn	Appd	Date
0	ISSUE			30/10/2018

ARM ARCHITECTURE
 LEVEL 11/222 RUNDENS LANE MELBOURNE VICTORIA 3000 AUS
 T 03 8613 1888 F 03 8613 1889
 mail@armarchitecture.com.au
 ARM 2 475 942 200
 www.armarchitecture.com.au

LEGEND - SCOPE
 THIS LEGEND APPLIES TO ALL NEW CONSTRUCTION PHASE DRAWINGS. DOES NOT APPLY TO EXISTING CONDITIONS.

- AREA SHOWN IN GREY WASH DEPICTS SCOPE OF NEW WORKS
- AREA SHOWN IN WHITE WASH DEPICTS SCOPE OF NEW WORKS
- AREA SURROUNDED BY GREEN DASHED LINES DEPICTS TENDER OPTION

SOHT GENERAL NOTES

- ALL DIMENSIONS AND SIZES ARE IN MILLIMETRES.
- DO NOT SCALE DRAWINGS. USE FIGURED DIMENSIONS ONLY.
- INFORMATION INDICATED IN THIS DOCUMENT MAY BE CRUCIAL TO THE SAFE AND PROPER FUNCTIONING OF THE SYDNEY OPERA HOUSE. DO NOT ALTER ANY ASPECT WITHOUT WRITTEN PERMISSION.
- ALL NEW WORKS MUST COMPLY WITH THE SYDNEY OPERA HOUSE BUILDING SERVICES STANDARD SPECIFICATION (BSSS) AND RELEVANT AUSTRALIAN STANDARDS. NEW WORKS MUST ALSO COMPLY WITH THE REQUIREMENTS OF THE BUILDING CODES OF AUSTRALIA.

SOHT COPYRIGHT
 THIS DRAWING AND DESIGN ARE SUBJECT TO COPYRIGHT AND SHALL NOT BE COPIED IN ANY FORM WITH THE WRITTEN PERMISSION OF THE SYDNEY OPERA HOUSE TRUST

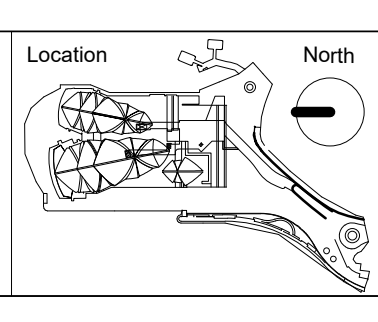

DEVELOPMENT APPLICATION ISSUE

Contract	BDM-168
Dwn	PRB
Date	2/10/2018
Ckd	AR
Scale	1:100@81

Project BUILDING RENEWAL PROJECT - CONCERT HALL

Title	EXISTING CONDITIONS FLOOR PLAN - LEVEL 1+30
-------	---

Location	Drawing No.	Sheet	Rev.
CHVA	49-BR-ARM01	DA0505	D B1

Sydney Opera House Trust
 GPO Box 4274 Sydney NSW Australia 2001
 Phone: +61 2 9256 7541
 email: info@sydneyoperahouse.com
 © Sydney Opera House Trust

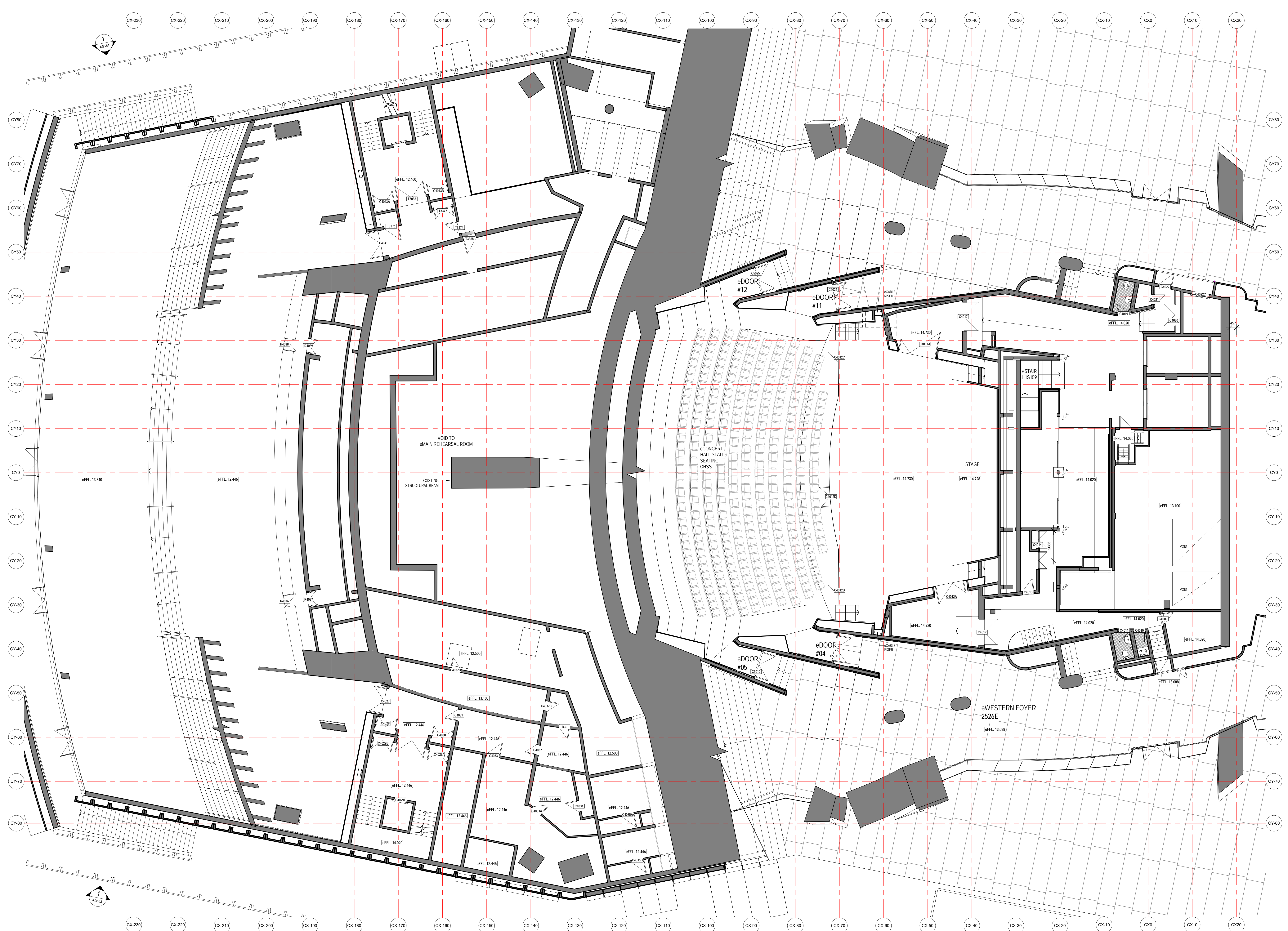

LEGEND - EXISTING CONDITIONS

—	EXISTING WALL
—	EXISTING FLOOR
—	EXISTING STEEL TRUSS
—	EXISTING DOOR
⊕	ANYTHING PREFIXED WITH ⊕ DENOTES EXISTING
RL	FINISHED OR RELATIVE LEVEL
SSSL 3700	EXISTING STRUCTURAL SLAB LEVEL
FFL 3700	EXISTING FINISHED FLOOR LEVEL

LEGEND - SCOPE

THIS LEGEND APPLIES TO ALL NEW CONSTRUCTION PHASE DRAWINGS. DOES NOT APPLY TO EXISTING CONDITIONS.

—	AREA SHOWN IN GREY WASH DEPICTS SCOPE OF NEW WORKS
—	AREA SHOWN IN WHITE WASH DEPICTS SCOPE OF NEW WORKS
—	AREA SURROUNDED BY GREEN DASHED LINES DEPICTS TENDER OPTION

SOHT GENERAL NOTES

- ALL DIMENSIONS AND SIZES ARE IN MILLIMETRES.
- DO NOT SCALE DRAWINGS. USE FIGURED DIMENSIONS ONLY. INFORMATION INDICATED IN THIS DOCUMENT MAY BE CRUCIAL TO THE SAFE AND PROPER FUNCTIONING OF THE SYDNEY OPERA HOUSE. DO NOT ALTER ANY ASPECT WITHOUT WRITTEN PERMISSION OF THE SYDNEY OPERA HOUSE TRUST.
- ALL NEW WORKS MUST COMPLY WITH THE SYDNEY OPERA HOUSE BUILDING SERVICES STANDARD SPECIFICATION (BSSS) AND RELEVANT AUSTRALIAN STANDARDS. NEW WORKS MUST ALSO COMPLY WITH THE REQUIREMENTS OF THE BUILDING CODES OF AUSTRALIA.

SOHT COPYRIGHT

THIS DRAWING AND DESIGN ARE SUBJECT TO COPYRIGHT AND SHALL NOT BE COPIED IN ANY FORM WITH THE WRITTEN PERMISSION OF THE SYDNEY OPERA HOUSE TRUST

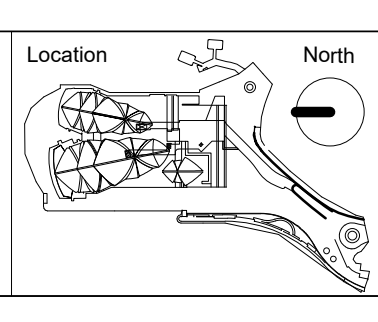

DEVELOPMENT APPLICATION ISSUE

Contract	BDM-168
Dwn	PRB
Ckd	Alt
Date	2/10/2018
Scale	1:100 @ 1

Project BUILDING RENEWAL PROJECT - CONCERT HALL

Title EXISTING CONDITIONS FLOOR PLAN - LEVEL 2 +42

Location	Drawing No.	Sheet	Rev:
CHVA	49-BR-ARM01	DA0506	D B1

Sydney Opera House Trust
GPO Box 4274 Sydney NSW Australia 2001
Phone: +61 2 9250 7541
email: info@sydneyoperahouse.com

© Sydney Opera House Trust

Issue	Description	Dwn	Appl	Date
0	ISSUE			20/10/2018

ARM ARCHITECTURE

LEVEL 11/522 RUNDERS LANE MELBOURNE VICTORIA 3000 AUS
T 03 8613 1888 F 03 8613 1889
mail@armarchitecture.com.au
ADV 2 475 242 250
www.armarchitecture.com.au

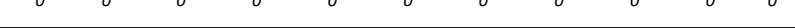

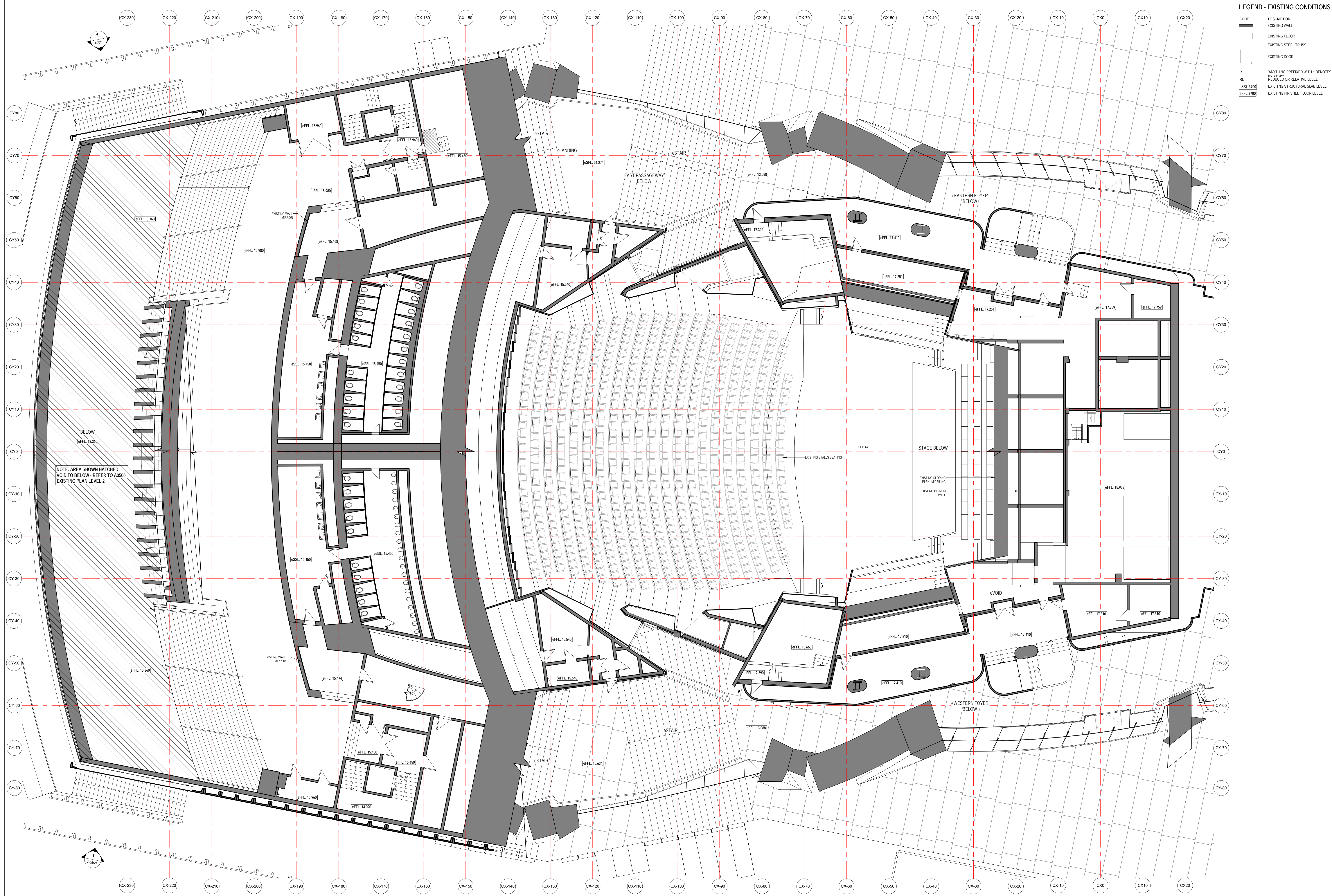

LEGEND - EXISTING CONDITIONS

CODE	DESCRIPTION
—	EXISTING WALL
□	EXISTING FLOOR
—	EXISTING STEEL TRUSS
—	EXISTING DOOR
e	ANYTHING PREFIXED WITH 'e' DENOTES EXISTING
RL	REDUCED OR RELATIVE LEVEL
eSSL 3700	EXISTING STRUCTURAL SLAB LEVEL
eFFL 3700	EXISTING FINISHED FLOOR LEVEL

NOTE: AREA SHOWN HATCHED - VOID TO BELOW - REFER TO A0506 EXISTING PLAN LEVEL 2

Issue No.	Description	Drawn By	Approved By	Date
0	ISSUE			20/10/2018

ARM
 ARCHITECTURE
 LEVEL 11/222 RUNNERS LANE MELBOURNE VICTORIA 3000 AUS
 T 03 8613 1888 F 03 8613 1889
 mail@armarchitecture.com.au
 409 2 475 942 320
 www.armarchitecture.com.au

LEGEND - SCOPE
(THIS LEGEND APPLIES TO ALL NEW CONSTRUCTION PHASE DRAWINGS. DOES NOT APPLY TO EXISTING CONDITIONS)

—	AREA SHOWN IN GREY WASH DEPICTS SCOPE OF NEW WORKS
—	AREA SHOWN IN WHITE WASH DEPICTS SCOPE OF NEW WORKS
—	AREA SURROUNDED BY GREEN DASHED LINES DEPICTS TENDER OPTION

SOHT GENERAL NOTES

- ALL DIMENSIONS AND SIZES ARE IN MILLIMETRES.
- DO NOT SCALE DRAWINGS. USE FIGURED DIMENSIONS ONLY.
- INFORMATION INDICATED IN THIS DOCUMENT MAY BE CRUCIAL TO THE SAFE AND PROPER FUNCTIONING OF THE SYDNEY OPERA HOUSE. DO NOT ALTER ANY ASPECT WITHOUT WRITTEN PERMISSION.
- ALL NEW WORKS MUST COMPLY WITH THE SYDNEY OPERA HOUSE BUILDING SERVICES STANDARD SPECIFICATION (BSST) AND RELEVANT AUSTRALIAN STANDARDS. NEW WORKS MUST ALSO COMPLY WITH THE REQUIREMENTS OF THE BUILDING CODES OF AUSTRALIA.

SOHT COPYRIGHT
 THIS DRAWING AND DESIGN ARE SUBJECT TO COPYRIGHT AND SHALL NOT BE COPIED IN ANY FORM WITH THE WRITTEN PERMISSION OF THE SYDNEY OPERA HOUSE TRUST

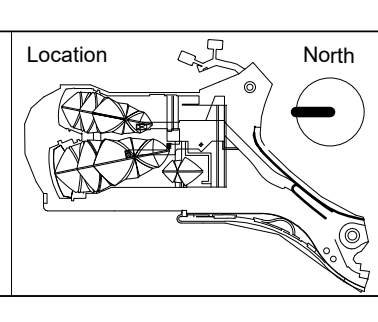

DEVELOPMENT APPLICATION ISSUE

Contract	BDM-168
Date	2/10/2018
Scale	1:100 @ B1

Project: BUILDING RENEWAL PROJECT - CONCERT HALL

Title: EXISTING CONDITIONS FLOOR PLAN - LEVEL 3+51

Location	CHVA	Drawing No.	49-BR-ARM01	Sheet	DA0507	Rev.	D B1
----------	------	-------------	-------------	-------	--------	------	------

LEGEND - EXISTING CONDITIONS

■	EXISTING WALL
□	EXISTING FLOOR
—	EXISTING STEEL TRUSS
⌵	EXISTING DOOR
e	ANYTHING PREFIEXED WITH e DENOTES EXISTING OR RELATIVE LEVEL
RL	EXISTING STRUCTURAL SLAB LEVEL
±SSSL 3700	EXISTING STRUCTURAL SLAB LEVEL
±FFL 3700	EXISTING FINISHED FLOOR LEVEL

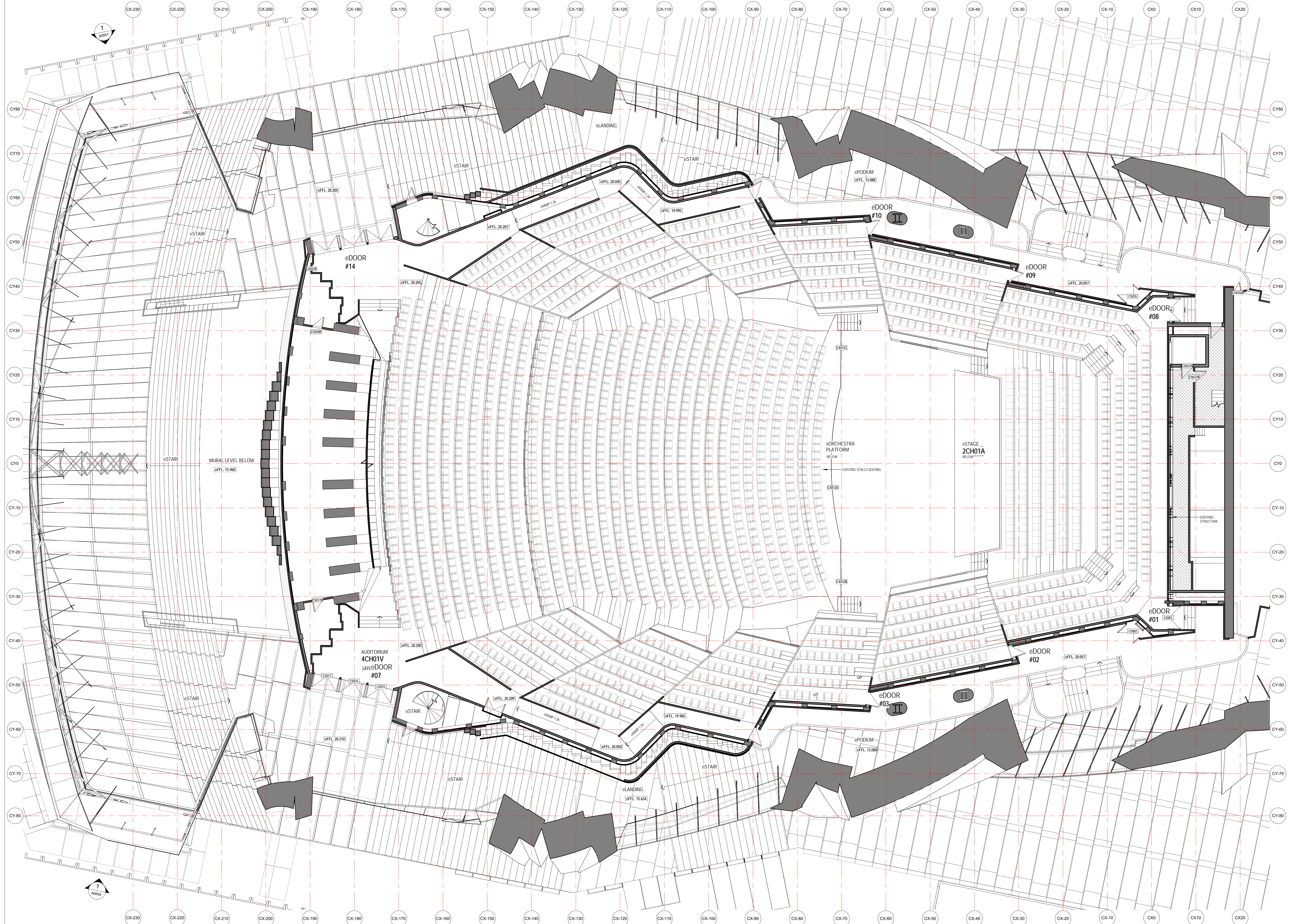

Issue	Description	Dwn	Appd	Date
0	ISSUE			20/10/2018

ARM
ARCHITECTURE
LEVEL 11/522 HUNTERS LANE MELBOURNE VICTORIA 3000 AUS
T 03 8613 1888 F 03 8613 1889
mail@armarchitecture.com.au
ADV 02 475 942 320
www.armarchitecture.com.au

LEGEND - SCOPE
(THIS LEGEND APPLIES TO ALL NEW CONSTRUCTION PHASE DRAWINGS, DOES NOT APPLY TO EXISTING CONDITIONS)

■	AREA SHOWN IN GREY WASH DEPICTS SCOPE OF NEW WORKS
□	AREA SHOWN IN WHITE WASH DEPICTS SCOPE OF NEW WORKS
□	AREA SURROUNDED BY GREEN DASHED LINES DEPICTS TENDER OPTION

SOHT GENERAL NOTES

- ALL DIMENSIONS AND SIZES ARE IN MILLIMETRES.
- DO NOT SCALE DRAWINGS. USE FIGURED DIMENSIONS ONLY.
- INFORMATION INDICATED IN THIS DOCUMENT MAY BE CRUCIAL TO THE SAFE AND PROPER FUNCTIONING OF THE SYDNEY OPERA HOUSE. DO NOT ALTER ANY ASPECT WITHOUT WRITTEN PERMISSION.
- ALL NEW WORKS MUST COMPLY WITH THE SYDNEY OPERA HOUSE BUILDING SERVICES STANDARD SPECIFICATION (BSSS) AND RELEVANT AUSTRALIAN STANDARDS. NEW WORKS MUST ALSO COMPLY WITH THE REQUIREMENTS OF THE BUILDING CODES OF AUSTRALIA.

SOHT COPYRIGHT
THIS DRAWING AND DESIGN ARE SUBJECT TO COPYRIGHT AND SHALL NOT BE COPIED IN ANY FORM WITH THE WRITTEN PERMISSION OF THE SYDNEY OPERA HOUSE TRUST

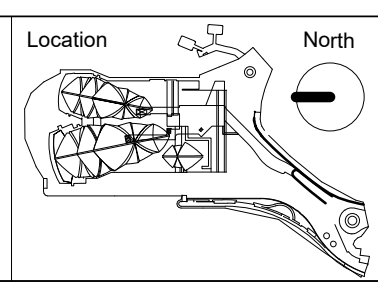

DEVELOPMENT APPLICATION ISSUE

Contract	BDM-168
Dwn	PRB
Date	2/10/2018
Ckd	AM
Scale	1:100@81

Project BUILDING RENEWAL PROJECT - CONCERT HALL

Title EXISTING CONDITIONS FLOOR PLAN - LEVEL 4 +61

Location	Drawing No.	Sheet	Rev.
CHVA	49-BR-ARM01	DA0508	D B1

Sydney Opera House Trust
GPO Box 4274 Sydney NSW Australia 2001
Phone +61 2 9250 7541
email info@sydneyoperahouse.com

© Sydney Opera House Trust

LEGEND - EXISTING CONDITIONS

CODE	DESCRIPTION
EW	EXISTING WALL
EF	EXISTING FLOOR
EST	EXISTING STEEL TRUSS
ED	EXISTING DOOR
e	ANYTHING PREFIXED WITH 'e' DENOTES EXISTING
RL	REDUCED OR RELATIVE LEVEL
eSSL 3700	EXISTING STRUCTURAL SLAB LEVEL
eFFL 3700	EXISTING FINISHED FLOOR LEVEL

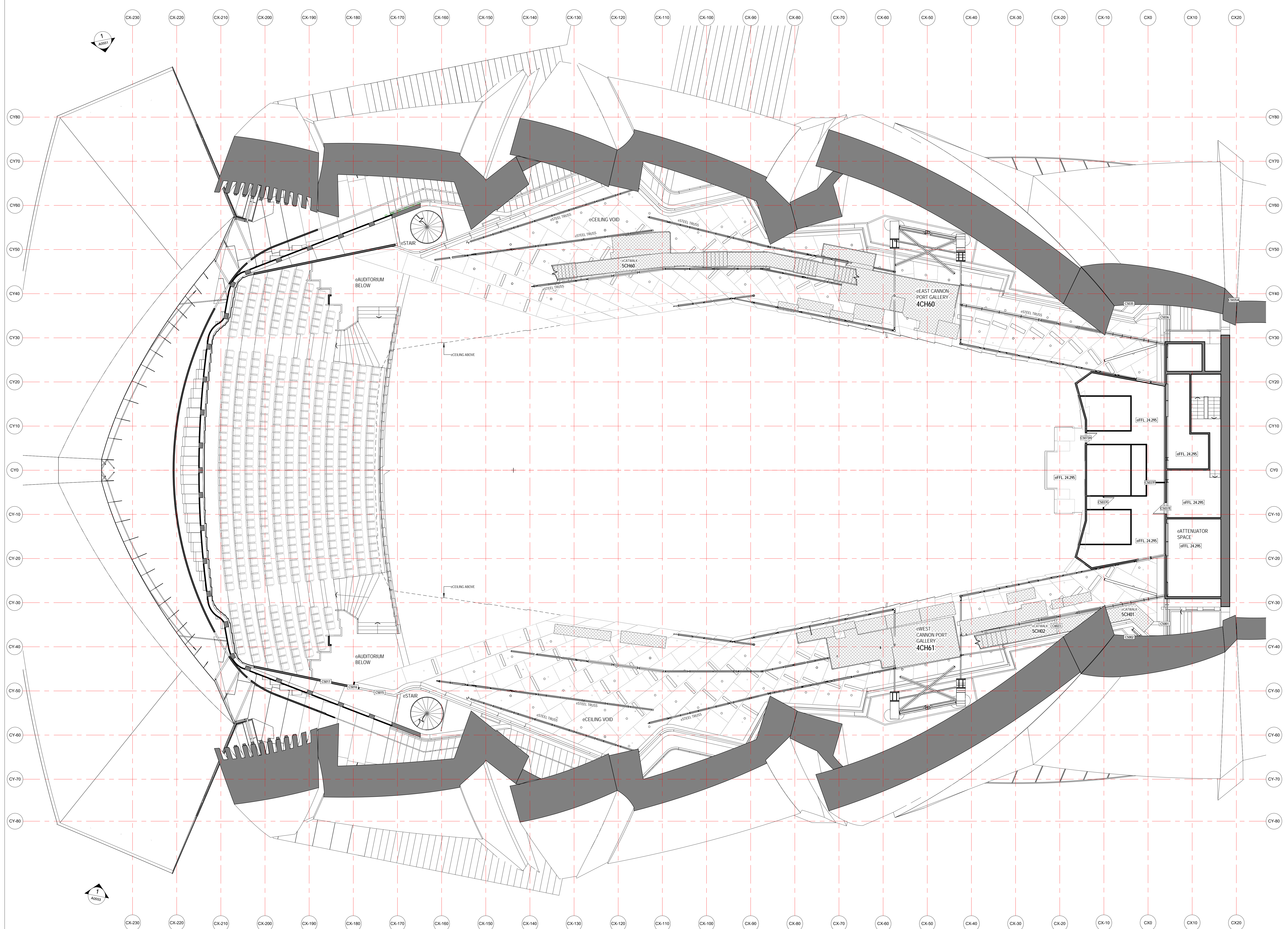

Issue	Description	Dwn	Appl	Date
0	ISSUE			20/10/2018

ARM
 ARCHITECTURE
 LEVEL 11/322 RIVERSIDE LANE MELBOURNE VICTORIA 3000 AUS
 T 03 8613 1888 F 03 8613 1889
 mail@armarchitecture.com.au
 ADV 22 475 942 350
 www.armarchitecture.com.au

LEGEND - SCOPE
 THIS LEGEND APPLIES TO ALL NEW CONSTRUCTION PHASE DRAWINGS. DOES NOT APPLY TO EXISTING CONDITIONS.

AREA SHOWN IN GREY WASH	DEPCTS SCOPE OF NEW WORKS
AREA SHOWN IN WHITE WASH	DEPCTS SCOPE OF NEW WORKS
AREA SURROUNDED BY GREEN DASHED LINES	DEPCTS TENDER OPTION

SOHT GENERAL NOTES

- ALL DIMENSIONS AND SIZES ARE IN MILLIMETRES.
- DO NOT SCALE DRAWINGS. USE FIGURED DIMENSIONS ONLY.
- INFORMATION INDICATED IN THIS DOCUMENT MAY BE CRUCIAL TO THE SAFE AND PROPER FUNCTIONING OF THE SYDNEY OPERA HOUSE. DO NOT ALTER ANY ASPECT WITHOUT WRITTEN PERMISSION.
- ALL NEW WORKS MUST COMPLY WITH THE SYDNEY OPERA HOUSE BUILDING SERVICES STANDARD SPECIFICATION (BSSS) AND RELEVANT AUSTRALIAN STANDARDS. NEW WORKS MUST ALSO COMPLY WITH THE REQUIREMENTS OF THE BUILDING CODES OF AUSTRALIA.

SOHT COPYRIGHT
 THIS DRAWING AND DESIGN ARE SUBJECT TO COPYRIGHT AND SHALL NOT BE COPIED IN ANY FORM WITH THE WRITTEN PERMISSION OF THE SYDNEY OPERA HOUSE TRUST

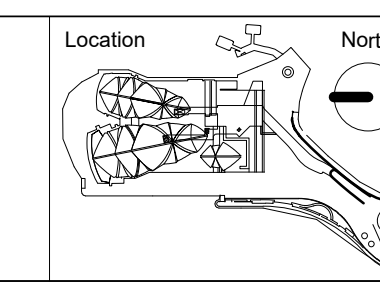

DEVELOPMENT APPLICATION ISSUE

Contract	BDM-168
Dwn	PRB
Date	2/10/2018
Ckd	AR
Scale	1:100 @ B1

Project BUILDING RENEWAL PROJECT - CONCERT HALL

Title EXISTING CONDITIONS FLOOR PLAN - LEVEL 5+70

Location	Drawing No.	Sheet	Rev:
CHVA	49-BR-ARM01	DA0509	D B1

Sydney Opera House Trust
 GPO Box 4274 Sydney NSW Australia 2001
 Phone +61 2 9250 7541
 email info@sydneyoperahouse.com

© Sydney Opera House Trust

LEGEND - EXISTING CONDITIONS

CODE	DESCRIPTION
—	EXISTING WALL
—	EXISTING FLOOR
—	EXISTING STEEL TRUSS
—	EXISTING DOOR
e	ANYTHING PREFIXED WITH e DENOTES EXISTING
RL	REDUCED OR RELATIVE LEVEL
SSSL 3700	EXISTING STRUCTURAL SLAB LEVEL
FFFL 3700	EXISTING FINISHED FLOOR LEVEL

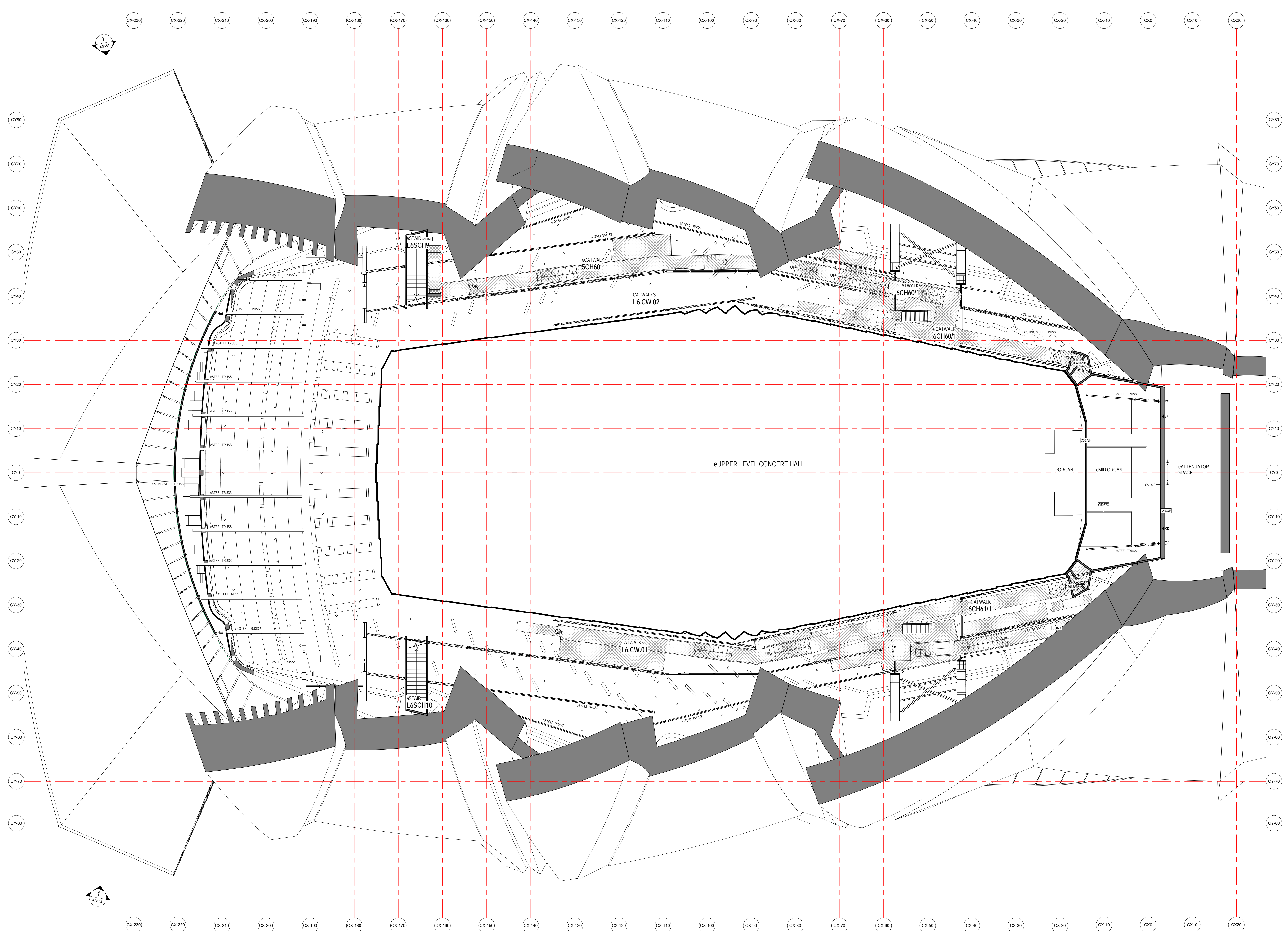

Issue	Description	Dwn	Appd	Date
0	ISSUE			20/10/2018

ARM
 ARCHITECTURE
 LEVEL 11/522 RUNDERS LANE MELBOURNE VICTORIA 3000 AUS
 T 03 8613 1888 F 03 8613 1889
 mail@armarchitecture.com.au
 ARM 2 475 942 350
 www.armarchitecture.com.au

LEGEND - SCOPE
 THIS LEGEND APPLIES TO ALL NEW CONSTRUCTION PHASE DRAWINGS. DOES NOT APPLY TO EXISTING CONDITIONS.

—	AREA SHOWN IN GREY WASH DEPICTS SCOPE OF NEW WORKS
—	AREA SHOWN IN WHITE WASH DEPICTS SCOPE OF NEW WORKS
—	AREA SURROUNDED BY GREEN DASHED LINES DEPICTS TENDER OPTION

SOHT GENERAL NOTES

- ALL DIMENSIONS AND SIZES ARE IN MILLIMETRES.
- DO NOT SCALE DRAWINGS. USE FIGURED DIMENSIONS ONLY.
- INFORMATION INDICATED IN THIS DOCUMENT MAY BE CRUCIAL TO THE SAFE AND PROPER FUNCTIONING OF THE SYDNEY OPERA HOUSE. DO NOT ALTER ANY ASPECT WITHOUT WRITTEN PERMISSION.
- ALL NEW WORKS MUST COMPLY WITH THE SYDNEY OPERA HOUSE BUILDING SERVICES STANDARD SPECIFICATION (BSSS) AND RELEVANT AUSTRALIAN STANDARDS. NEW WORKS MUST ALSO COMPLY WITH THE REQUIREMENTS OF THE BUILDING CODES OF AUSTRALIA.

SOHT COPYRIGHT
 THIS DRAWING AND DESIGN ARE SUBJECT TO COPYRIGHT AND SHALL NOT BE COPIED IN ANY FORM WITH THE WRITTEN PERMISSION OF THE SYDNEY OPERA HOUSE TRUST

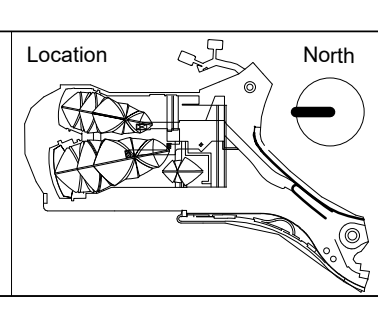

DEVELOPMENT APPLICATION ISSUE

Contract	BDM-168
Dwn	PRB
Date	2/10/2018
Ckd	AR
Scale	1:100@B1

Project BUILDING RENEWAL PROJECT - CONCERT HALL

Title EXISTING CONDITIONS FLOOR PLAN - LEVEL 6 +85

Sydney Opera House Trust
 GPO Box 4274 Sydney NSW Australia 2001
 Phone: +61 2 9250 7541
 email: info@sydneyoperahouse.com

© Sydney Opera House Trust

Location	Drawing No:	Sheet:	Rev:
CHVA	49-BR-ARM01	DA0510	D B1

LEGEND - EXISTING CONDITIONS

CODE	DESCRIPTION
EXISTING WALL	EXISTING WALL
EXISTING FLOOR	EXISTING FLOOR
EXISTING STEEL TRUSS	EXISTING STEEL TRUSS
EXISTING DOOR	EXISTING DOOR
e	ANYTHING PREFIXED WITH e DENOTES EXISTING
RL	REDUCED OR RELATIVE LEVEL
SSSL 3700	EXISTING STRUCTURAL SLAB LEVEL
FFFL 3700	EXISTING FINISHED FLOOR LEVEL

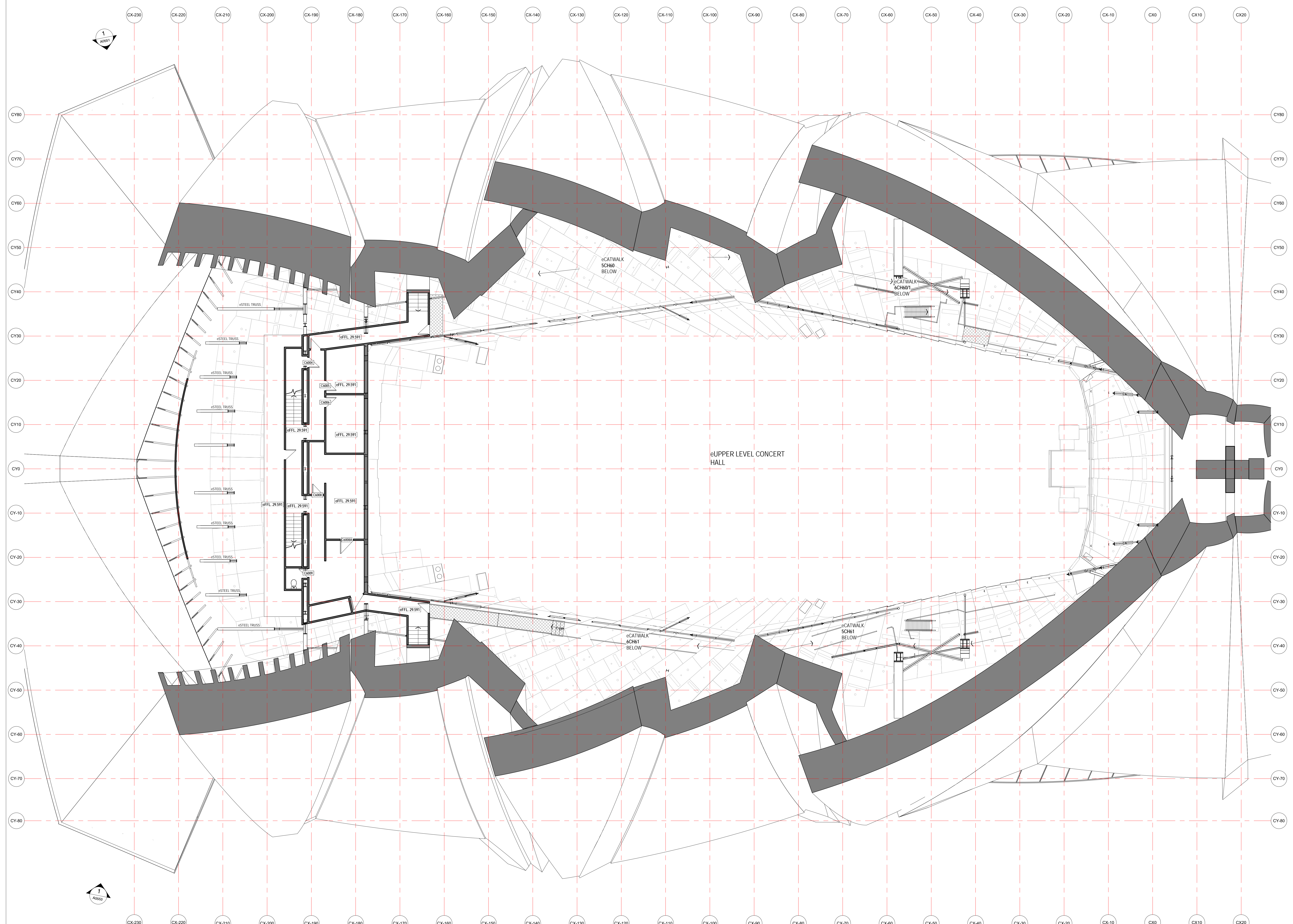

Issue	Description	Dwn	App'd	Date
0	ISSUE			20/10/2018

ARM
 ARCHITECTURE
 LEVEL 11/323 RINDERS LANE MELBOURNE VICTORIA 3000 AUS
 T 03 8613 1888 F 03 8613 1889
 mail@armarchitecture.com.au
 ABN 22 475 292 320
 www.armarchitecture.com.au

LEGEND - SCOPE
 THIS LEGEND APPLIES TO ALL NEW CONSTRUCTION PHASE DRAWINGS. CHECK NOT APPLICABLE TO EXISTING CONDITIONS.

AREA SHOWN IN GREY WASH	DEPCTS SCOPE OF NEW WORKS
AREA SHOWN IN WHITE WASH	DEPCTS SCOPE OF NEW WORKS
AREA SURROUNDED BY GREEN DASHED LINES	DEPCTS TENDER OPTION

SOHT GENERAL NOTES

1. ALL DIMENSIONS AND SIZES ARE IN MILLIMETRES.
2. DO NOT SCALE DRAWINGS. USE FIGURED DIMENSIONS ONLY.
3. INFORMATION INDICATED IN THIS DOCUMENT MAY BE CRUCIAL TO THE SAFE AND PROPER FUNCTIONING OF THE SYDNEY OPERA HOUSE. DO NOT ALTER ANY ASPECT WITHOUT WRITTEN PERMISSION OF THE SYDNEY OPERA HOUSE TRUST.
4. ALL NEW WORKS MUST COMPLY WITH THE SYDNEY OPERA HOUSE BUILDING SERVICES STANDARD SPECIFICATION (BSSS) AND RELEVANT AUSTRALIAN STANDARDS. NEW WORKS MUST ALSO COMPLY WITH THE REQUIREMENTS OF THE BUILDING CODES OF AUSTRALIA.

SOHT COPYRIGHT
 THIS DRAWING AND DESIGN ARE SUBJECT TO COPYRIGHT AND SHALL NOT BE COPIED IN ANY FORM WITH THE WRITTEN PERMISSION OF THE SYDNEY OPERA HOUSE TRUST

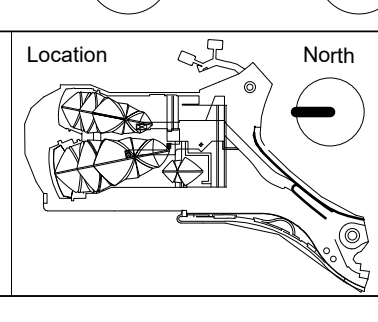

Status		Date	
Development Application	BDM-168	21/02/18	
Contract	CHVA	Scale	1:100 @ B1

Project		Title	
BUILDING RENEWAL PROJECT - CONCERT HALL	EXISTING CONDITIONS FLOOR PLAN - LEVEL 7 +100	Sheet	Rev:
CHVA	49-BR-ARM01	DA0511	D B1

Sydney Opera House Trust
 GPO Box 4274 Sydney NSW Australia 2001
 Phone +61 2 9250 7541
 email info@sydneyoperahouse.com

© Sydney Opera House Trust

LEGEND - EXISTING CONDITIONS

CODE	DESCRIPTION
EW	EXISTING WALL
EF	EXISTING FLOOR
EST	EXISTING STEEL TRUSS
ED	EXISTING DOOR
e	*ANYTHING PREFIXED WITH 'e' DENOTES EXISTING
RL	REDUCED OR RELATIVE LEVEL
SSSL 3700	EXISTING STRUCTURAL SLAB LEVEL
FFL 3700	EXISTING FINISHED FLOOR LEVEL

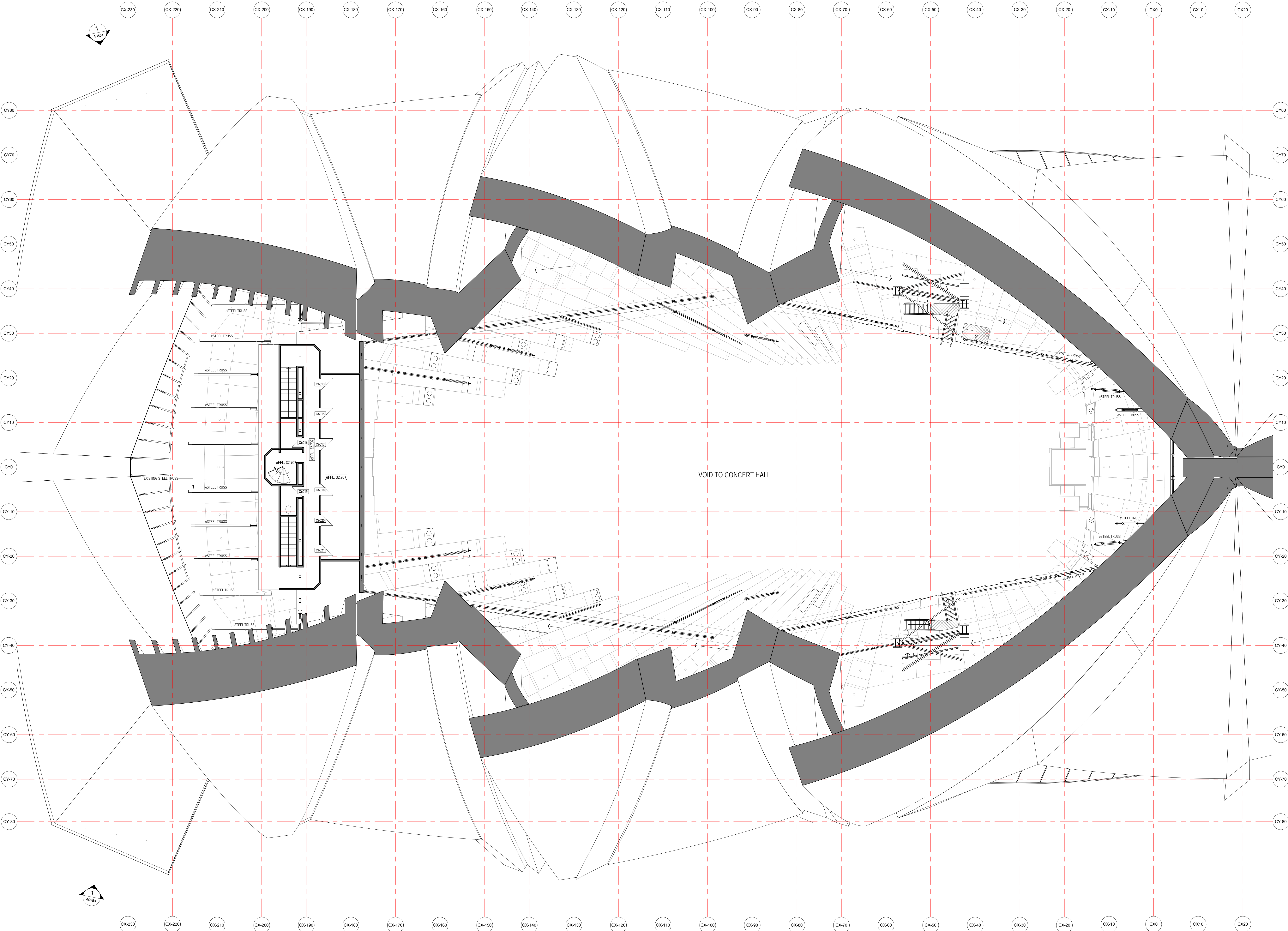

LEGEND - SCOPE
(THIS LEGEND APPLIES TO ALL NEW CONSTRUCTION PHASE DRAWINGS. DOES NOT APPLY TO EXISTING CONDITIONS)

	AREA SHOWN IN GREY WASH DEPICTS SCOPE OF NEW WORKS
	AREA SHOWN IN WHITE WASH DEPICTS SCOPE OF NEW WORKS
	AREA SURROUNDED BY GREEN DASHED LINES DEPICTS TENDER OPTION

SOHT GENERAL NOTES

1. ALL DIMENSIONS AND SIZES ARE IN MILLIMETRES.
2. DO NOT SCALE DRAWINGS. USE FIGURED DIMENSIONS ONLY.
3. INFORMATION INDICATED IN THIS DOCUMENT MAY BE CRUCIAL TO THE SAFE AND PROPER FUNCTIONING OF THE SYDNEY OPERA HOUSE. DO NOT ALTER ANY ASPECT WITHOUT WRITTEN PERMISSION.
4. ALL NEW WORKS MUST COMPLY WITH THE SYDNEY OPERA HOUSE BUILDING SERVICES STANDARD SPECIFICATION (BSSS) AND RELEVANT AUSTRALIAN STANDARDS. NEW WORKS MUST ALSO COMPLY WITH THE REQUIREMENTS OF THE BUILDING CODES OF AUSTRALIA.

SOHT COPYRIGHT
 THIS DRAWING AND DESIGN ARE SUBJECT TO COPYRIGHT AND SHALL NOT BE COPIED IN ANY FORM WITH THE WRITTEN PERMISSION OF THE SYDNEY OPERA HOUSE TRUST

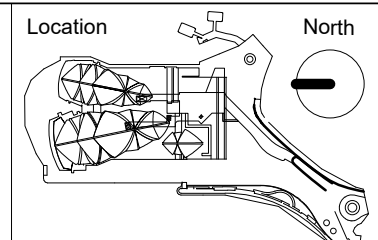

Status		DEVELOPMENT APPLICATION ISSUE	
Contract	BDM-168	Date	2/10/2018
Dwn	PRB	Scale	1:100@B1
Ckd	AR		

Project	BUILDING RENEWAL PROJECT - CONCERT HALL
Title	EXISTING CONDITIONS FLOOR PLAN - LEVEL 7A

Sydney Opera House Trust GPO Box 4274 Sydney NSW Australia 2001 Phone: +61 2 9250 7541 email: info@sydneyoperahouse.com			
Location	Drawing No:	Sheet:	Rev:
CHVA	49-BR-ARM01	DA0512	D B1

Issue	Description	Dwn	Appl	Date
0	ISSUE			20/10/2018

ARM
 ARCHITECTURE
 LEVEL 11/522 RUNDERS LANE MELBOURNE VICTORIA 3000 AUS
 T: 03 8613 1888 F: 03 8613 1889
 mail@armarchitecture.com.au
 ADV: 22 475 942 320
 www.armarchitecture.com.au

0 10 20 30 40 50 60 70 80 90 100 MILLIMETRES ON ORIGINAL