

The title "Development Application ACCESS REPORT" is displayed in a large, bold, black sans-serif font. The word "ACCESS" is significantly larger and bolder than the other words. The background of the page features a large blue diagonal shape on the left and a grey diagonal shape at the bottom, with a photograph of a wheelchair and a person's feet on a textured surface.

Reference Number: 25120

Client: Ming Yang & John Wu

Site Address: 16-20 Middle Harbour Road, Lindfield
NSW



Vista Access Architects Pty. Ltd.

www.accessarchitects.com.au

admin@accessarchitects.com.au

PO Box 353, Kingswood NSW 2747

ABN: 82124411614

Executive Summary and Design Compliance Statement

This Access Compliance Report is to accompany a Development Application (DA) for the development proposed at **16-20 Middle Harbour Road, Lindfield NSW**

The development is within Ku-ring-gai Council LGA and proposes a **New Building**. The Council requires 15% of units to be to a Platinum Level and all remainder units to be to Silver Level in accordance with the Livable Housing Design Provisions Australia.

The development proposes the following:

Residential units	98
Silver Livable Housing Units	83
Platinum Level Units	15
Accessible parking spaces for residential component	15

The development has building classification as detailed below:

- Class 2 (building containing more than 2 SOUs i.e., sole-occupancy units)
- Class 7a (car park)
- Class 10b (swimming pool)

This report is based on the relevant components of:

- Building Code of Australia (BCA) 2022, Volume 1- Performance requirements of D1P1, D1P2, D1P8, D1P9, E3P4, F4P1 and Parts D4, E3 and F4 (where applicable)
- Disability (Access to Premises - Buildings) Amendment Standards 2010
- AS1428.1-2021 Part 1: General requirements for access, including any amendments
- AS1428.4.1-2009 Part 4.1: TGSIs (Tactile ground surface indicators), including any amendments
- AS2890.6-2009 Part 6: Off-street parking for people with disabilities.
- AS4299-1995 Adaptable Housing
- AS1735.12-1999 - Lifts, escalators and moving walks, Part 12
- Livable Housing Australia's Livable Housing Design Guidelines- Fourth Edition

The assessment of the proposed development has been undertaken to the extent necessary to issue DA consent under the Environmental Planning and Assessment Act. The proposal achieves the spatial requirements to provide access for people with a disability and it is assumed that assessment of the detailed requirements such as assessment of internal fit-out, details of stairs, ramps and other features will occur at CC (Construction Certificate) stage.

By compliance with the recommendation in this report, the development complies with the requirements of:

- Access Code of **Disability (Access to Premises - Buildings) Amendment Standards 2010**, and the Disability Access relevant sections of applicable BCA (Building Code of Australia)/ NCC (National Construction Code)
- Livable units comply with the requirements of State Environmental Planning (Housing) 2021 (previously known as SEPP 65), Clause 43C which requires consideration of the Apartment Design Guide (ADG). ADG Chapter 4, Objective 4Q1, notes the requirement of 20% of the units to comply with Livable Housing Australia's Silver Level
- 15 Dwellings comply with Livable Housing Australia's Platinum Level, remaining dwellings comply with Livable Housing Australia's Silver Level,

Note: At the time of issuing this report the **Disability (Access to Premises - Buildings) Amendment (2024 Measures No. 1) Standards 2024** has been released which references AS1428.1-2021 which conflicts with the BCA/NCC2022 referencing AS1428.1-2009. It is our opinion that AS1428.1-2021 is to be used for purposes of compliance with APS which is a Federal Act and therefore higher in the hierarchy of legislation than the BCA/NCC. However, this would mean that any feature of AS1428.1-2021 that is used in this project that differs from the requirements of AS1428.1-2009 will need a Performance Solution to comply with the BCA/NCC

The ABCB (Australian Building Codes Board) has issued a directive noting that Disability (Access to Premises - Buildings) Amendment Standards 2010 is still applicable along with AS1428.1-2009. Therefore this report notes the requirements as per Disability (Access to Premises - Buildings) Amendment Standards 2010 and AS1428.1-2009.

The information contained in this statement is true and accurate to the best of our knowledge. Our qualifications and accreditations are listed below.

Assessed by

Vanessa Griffin

Accredited Access Consultant and LHA Assessor
ACAA Accredited Membership number 500
Qualified- Certificate IV in Access Consulting
LHA Assessor Licence number 20035



Peer reviewed by

Farah Madon

Accredited Access Consultant and LHA Assessor
ACAA Accredited Membership number 281
Qualified- Diploma in Access Consulting
LHA Assessor Licence number 10032



Vista **Access Architects** Pty. Ltd.

Relevant Dates:

Fee proposal, number FP-250348 dated **6-05-2025**. Fee proposal was accepted by Client on **09-05-2025**

Assessed Drawings:

The following drawings by PTI Architects have been assessed for compliance.

Drawing no	Issue	Date	Details
01	A	12-06-2025	Unit Schedule
11	A	12-06-2025	Basement 3
12	A	12-06-2025	Basement 2
13	A	12-06-2025	Basement 1
14	A	12-06-2025	Lower ground floor plan
15	A	12-06-2025	Upper ground and level 1 floor plan
16	A	12-06-2025	Level 2 floor plan
17	A	12-06-2025	Level 3 floor plan
18	A	12-06-2025	Level 4 floor plan
19	A	12-06-2025	Level 5 floor plan
20	A	12-06-2025	Level 6 floor plan
21	A	12-06-2025	Level 7 floor plan
22	A	12-06-2025	Level 8 floor plan
23	A	12-06-2025	Level 9 floor plan

Document Issue:

Issue	Date	Details
Draft 1	19-05-2025	Issued for Architect's review
Issue A	13-06-2025	Issued for DA

Limitations and Copyright information:

This report is based on discussions with the project architect and a review of drawings and other relevant documentation provided to us. No site visit was undertaken for the purposes of this report.

This assessment is based on the provided drawings and not based on constructed works; hence the assessment will provide assurance of compliance only if all the recommendations as listed in this report are complied with and constructed in accordance with the requirements of the current BCA, AS1428.1, AS2890.6 and other latest, relevant standards and regulations applicable at the time of construction.

Assessment is based on classification/use of the building. If the class of the building changes to any other building class, this access report will have to be updated accordingly.

Unless stated otherwise, all dimensions mentioned in the report are net (CLEAR) dimensions and are not to be reduced by projecting skirting, kerbs, handrails, lights, fire safety equipment, door handles less than 900mm above FFL (finished floor level) or any other fixtures/fit out elements. When we check drawings, we assume that the dimensions noted are CLEAR dimensions and therefore the Architect / Builder shall allow for construction tolerances.

Only some numerical requirements from relevant AS (Australian Standards) have been noted in the report and for further details and for construction purposes refer to the latest relevant AS.

This report and all its contents including diagrams are a copyright of Vista Access Architects Pty Ltd (VAA) and can only be used for the purposes of this specific project. Copy-pasting diagrams from this report to Architectural plans will constitute copyright infringement.

This report does not assess compliance matters related to WHS, Structural design, Services design, Parts of DDA other than those related to APS or Parts of BCA or Parts of AS other than those directly referenced in this report.

Where LHA assessments are provided there, we will use our best judgement regarding LHA assessments. However, we are not to be held responsible if another licenced LHA assessor comes to a different conclusion about compliance, certification, or allocation of a particular Quality mark to us as several items in LHA are subject to interpretation.

We have no ability to check for slip resistance of surfaces. All wet areas, parking areas, pavement markings shall have the appropriate slip resistance for the location.

Note: The Access report prepared for Development Application (DA) or Section 4.55 is not suitable for use for purposes of Construction Certificate (CC) Application.

Hierarchy of Access-related Legislation and Standards

Legislative documents (legally binding and mandatory)

Federal Acts Regulations

- Disability Discrimination Act 1992 (DDA)
- Environment Protection and Biodiversity Conservation 1999 (EPBC) Act; Parts 14 and 15 relating to the built environment.

DDA Standards

- Disability (Access to Premises- Building) Standards 2024 (APS)
- Disability Standards for Accessible Public Transport 2002 (DSAPT)
- Disability Standards for Education 2005

NCC Vol 1, 2 & 3

- Volume 1 Building Code of Australia (BCA) Class 2 to 10 buildings and some class 1b and 10a buildings relating to requirements for people with disabilities
- Volume 2 Building Code of Australia (BCA) Class 1 and 10 buildings
- Volume 3 Plumbing Code
- ABCB Livable Housing Design Standards (does not currently apply to NSW)

Australian Standards referenced in the BCA/NCC/DDA Standards

- AS 1428.1 (2009) Design for access and mobility, Part 1: General requirements for access - New building work (incorporating amendments 1 and 2)
- AS 1428.1 (2021) Design for access and mobility, Part 1: General requirements for access - New building work
- AS 1428.1 (2001) Design for access and mobility, Part 1: General requirements for access - New building work - Part I2 of the BCA and DSAPT only
- AS 1428.1 Supplement (1993) -Design for access and mobility, Part 1: General requirements for access — Buildings — Commentary (Supplement to AS 1428.1-1993)- Part I2 of the BCA and DSAPT only
- AS 1428.2 (1992) Design for access and mobility, Part 2: Enhanced and additional requirements — Buildings and facilities- Part I2 of the BCA and DSAPT only
- AS 1428.4 (1992) Design for access and mobility, Part 4: Tactile ground surface indicators for the orientation of people with vision impairment- Part I2 of the BCA and DSAPT only
- AS 1428.4.1 (2009) Design for access and mobility, Part 4.1: Means to assist the orientation of people with vision impairment — Tactile ground surface indicators (incorporating amendments 1 and 2)
- AS/NZS 2890.6 (2009) Parking facilities, Part 6: Off-street parking for people with disabilities
- AS 1735.12 (1999) Lifts, escalators and moving walks, Part 12: Facilities for persons with disabilities (incorporating amendment 1)
- AS 4586 (2013) Slip resistance classification of new pedestrian surface materials (incorporating amendment 1)
- AS 1680.0 (2009) Interior lighting, Part 0: Safe movement

SEPP

- State Environmental Planning Policies (SEPP)
- SEPP Housing 2021

LEP

Local Environmental Planning Policies (LEP)

DCP

Development control plans (DCP)

Hierarchy of Access-related Legislation and Standards (continued)

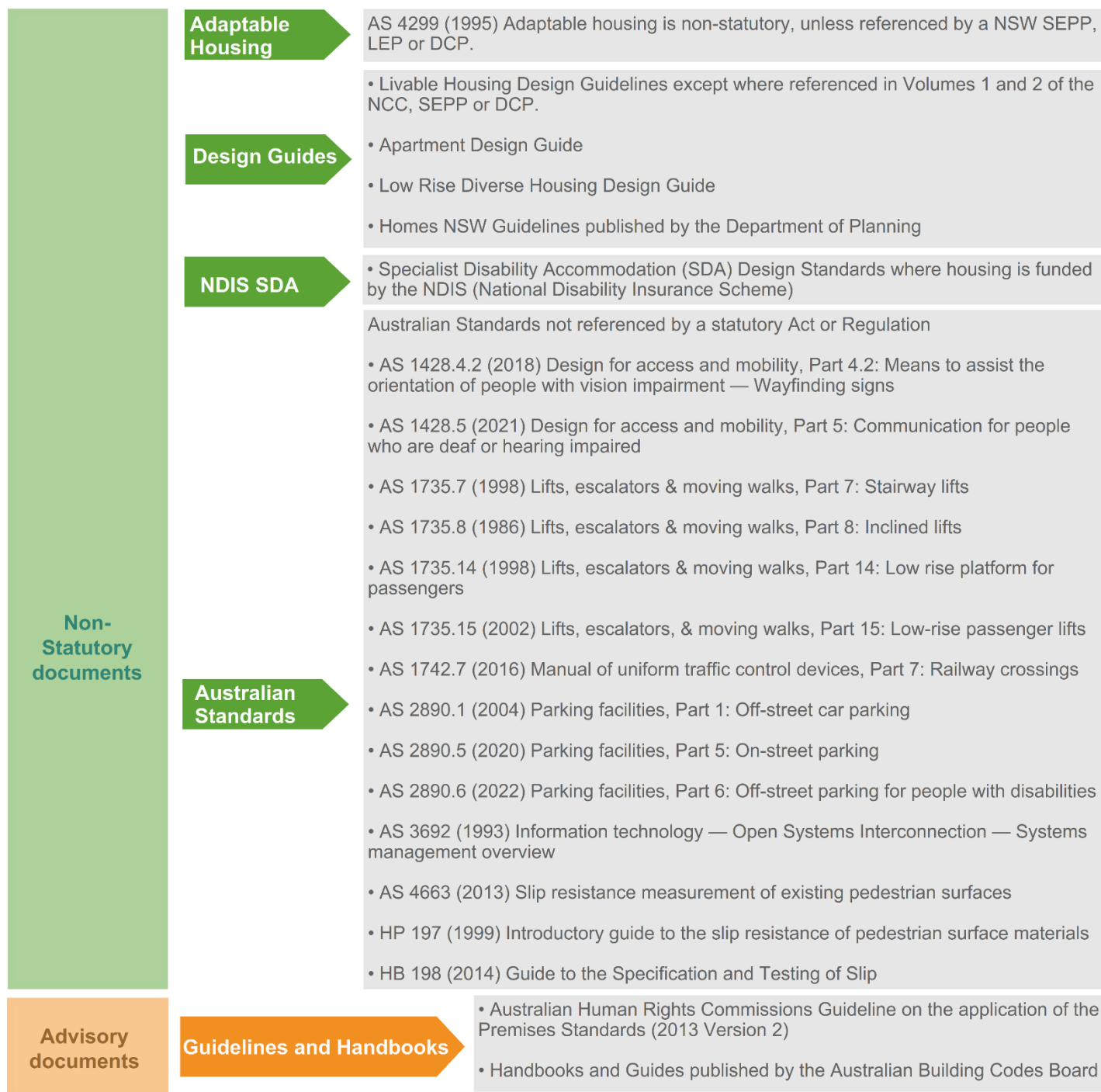

Disability Discrimination Act 1992

The federal Disability Discrimination Act 1992 provides protection for everyone in Australia against discrimination based on disability. Sections 23 and 24 of the DDA focuses on the provision of equitable and dignified access to premises, goods, services and facilities for people with mobility, sensory and cognitive disabilities.

Disability discrimination happens when people with a disability and their relatives, friends or carers, co-workers or associates are treated less fairly than people without a disability.

Compliance with Access to Premises Standards gives certainty to building certifiers, building developers and building managers that if access to new parts of the building is provided in accordance with these standards, the provision of that access to the extent covered by these standards, will not be unlawful under the DDA. This however applies only to the new buildings or new parts of an existing building and the “affected part”.

All areas outside the scope of these areas are still subject to the DDA. We cannot guarantee or certify for DDA compliance because DDA compliance can only be assessed by the courts where a complaint is made. Scope of DDA extends beyond the building fabric and also includes furniture, fittings, building management, employment, education, accommodation, clubs, sport and the administration of Commonwealth laws and programs.

Compliance assessment with Access related requirements of BCA and Disability (Access to Premises - Buildings) Amendment Standards 2010

Development consists of new buildings and therefore compliance is required to full development

BCA 2022 Part D4 Access for People with a Disability D4D2 General building Access requirements

SOU refers to a Sole Occupancy Unit

Requirement

Class 2 - building containing more than 2 SOUs i.e. sole-occupancy units
For residential use components, access is required:

- From a required accessible pedestrian entrance to at least 1 floor with SOUs and to the entry of door of each SOU on that level.
- To and within 1 of each type of room or space in common use.
- Where floor is accessed by an AS1428.1 ramp or lift, access is required to the entry doorway of each SOU on that level and to and within all common use areas on that level.

Compliance Complies

Comments

- Access has been provided from the main pedestrian entry doorway to the entry doors of all SOUs on all floor levels by means of accessible pathways and lifts
- Where common use areas are on a floor that is accessible by means of a ramp or lift (Lower Ground floor level and Upper Ground Floor Levels, and the swimming pool in this case), access has been provided to the same.
- Access has been provided to at least 1 of each common use areas. Where common use areas have a common use kitchen / laundry / BBQ area there to achieve minimum accessibility provide:
 - A minimum clear depth of 1540mm (for minimum length of 2070mm) forward of any common use kitchen / laundry / BBQ benchtop
 - A long lever tap, to any provided sink, with front of the benchtop (or where standalone sink/basin is provided, to the front of the sink/basin) to be maximum 300mm to operable parts of the tap. Operable parts mean the end point of the lever measure throughout its arc of movement. Alternatively, a sensor tap to be provided where the sensor can be activated within 300mm.
 - A (30x30mm switch size) double GPO fully within 300mm from the front edge of the benchtop.
- Access has been provided to bin chutes on all floor levels
- When bin chutes or bin storage is within a room, door circulation spaces and 1540x2070mm circulation space is required to the room clear of any bins or encroachments.
- Where bin chutes are provided the door handle of the bin chute is required to be a minimum of 500mm from any internal corner and located within the range of 900 to 1100mm from FFL.
- Access is required to common use letterbox area with min 1540x2070mm flat circulation space in front of the letterboxes with letterboxes for adaptable or accessible units being within 600 to 1100mm from FFL.
- All common use accessway widths are to be a minimum of 1M clear measured from skirting to skirting (increases to comply with door circulation spaces where doorways provided) with vertical clearance of at least 2M or 1.98M at doorways.

Additional advisory note for any common use kitchen/laundry or BBQ areas (where provided)

- It is suggested that kitchen / BBQ areas could be made partially accessible by providing a workspace of 900mm width next to the sink/cooktop/BBQ as vacant space (without cabinetry under the bench top)

Details to be verified at CC stage of works.

Requirement

Class 7a - Covered car park.

- To and within any level containing accessible carparking spaces.

Compliance Complies

Comments

- Access has been provided to all levels containing Accessible carparking spaces.
- All Accessway widths are to be a minimum of 1M clear (measured from skirting to skirting) with vertical clearance of at least 2M or 1.98M at doorways.

Details to be verified at CC stage of works.

Requirement

Class 10b - Swimming pool

- Swimming pool with perimeter more than 40M associated with Class 1b, 2, 3, 5, 6, 7, 8 or 9 that is required to be accessible, but not swimming pools for exclusive use of occupants of Class 1b or a SOU in Class 2 or 3 building.

Compliance Complies

Comments

Note: The swimming pool in this development has been classified as a Class 10b. If the classification is not Class 10b other requirements may apply. The BCA consultant to notify the Access Consultant if this is the case.

Perimeter of Pool is 33.4M

Perimeter of the swimming pool is less than 40M and therefore accessible means of entry within the swimming pool cannot be mandated, however swimming pool surrounds needs to be accessible.

Details to be verified at CC stage of works.

BCA 2022 Part D4D3 Access to buildings

Requirement

Accessway is required from:

- Main pedestrian entry at the site boundary for new buildings.
- Any other accessible building connected by a pedestrian link.
- Accessible car parking spaces.

Compliance Complies

Comments

- Access by means of 1:14 grade ramps have been provided from the main pedestrian entry at the site boundary.
- Access has been provided from accessible car parking spaces by means of lifts.

Details to be verified at CC stage of works.

Requirement

Common use External Walkway / Pedestrian access requirements as per AS1428:

- Accessible path of travel to have a gradient no steeper than 1 in 20 and a maximum cross fall or landings to be maximum of 1:40 (or maximum 1:33 for bitumen).
- Landings are required as below
 - for 1:20 grade walkways, 1200mm flat landings are required every 15M intervals
 - for 1:33 grade walkways, 1200mm flat landings are required every 25M intervals
 - for walkways with gradients between 1:33 and 1:20, 1200mm flat landings are required at intervals obtained by linear interpolation.
 - Above intervals can be increased by 30% where at least one side of walkway has a kerb or kerbrail with handrail or a wall with a handrail.
 - For walkways shallower than 1:33 no landings are required.
- The floor surface abutting the sides of the walkway to be provided with
 - a firm and level surface (of a different material) at the same level and grade of the walkway and extend horizontally for a minimum of 600mm, or
 - 150mm high kerb (can be reduced to 65 if required), or
 - kerb-rail with handrail, or
 - wall / fence / balustrade or similar barrier
- At 60° to 90° bends in pathways provide a 1500mmx1500mm space with maximum 500mm splay at internal corner.
- At 30° to <60° bends in pathways that are less than 1200mm provide a splay of 500mm at internal corner.

Compliance

Capable of compliance

Comments

Details to be verified at the CC stage of works.

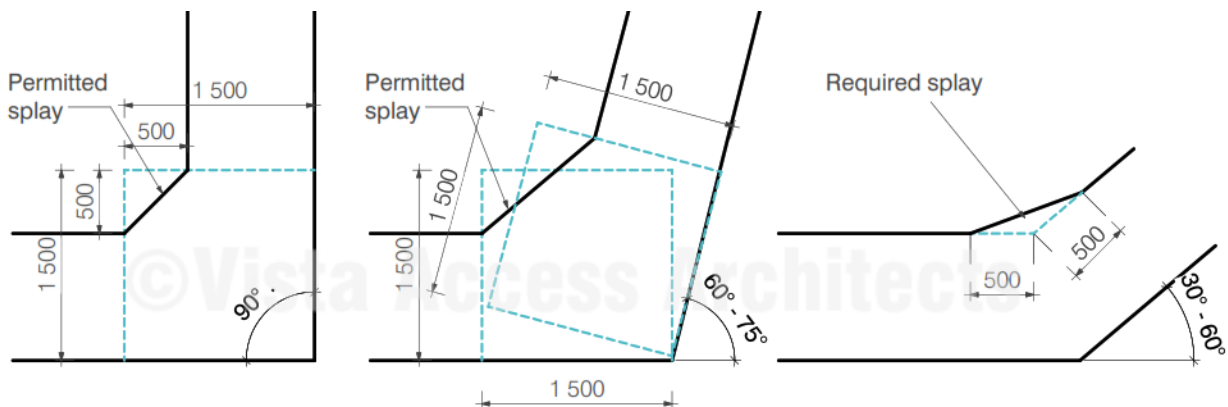

[Image description: Spatial requirements of walkways with bends as per AS1428.1]

Requirement

Requirements for Curved walkways, ramps, and landings

Curved ramps and walkways (with a maximum inside radius of 5M) and landings shall comply with the requirements of AS1428.1

Compliance

N/A

Comments

N/A.

Requirement

Common use floor or ground surfaces requirements:

- Use slip-resistant surfaces
- The texture of the surface is to be traversable by people who use a wheelchair and those with an ambulant or sensory disability.
- Abutment of surfaces is to have a smooth transition.
- Construction tolerances to be 0+/- 3mm vertical or 0+/-5mm, provided the edges are bevelled or rounded. This also applies to abutting pavers
- Where joints are provided in pavers, the mortar joints to be between 1-12mm with maximum depth of 2mm. Paver profile and mortar joint variation to not exceed 2mm.

Grates if used in the accessible path of travel are required to comply with the following:

- Circular openings maximum of 13 mm in diameter
- Slotted openings to be not greater than 13mm wide and not greater than 150mm long and be oriented so that the long dimension is transverse to the dominant direction of travel. Where slotted openings are less than 8mm, the length of the slots may continue across the width of paths of travel
- Linear openings to be oriented so that the longer dimension is transverse to the dominant direction of travel, except where linear openings are less than 8 mm wide, there the orientation is optional.

Timber decking and boardwalks

The gap between boards depends on the type of board used and the location of installation

- For decking boards maximum 150mm wide the installation to be have maximum 6mm gap.
- Adjacent boards shall be level within a maximum vertical 3mm tolerance
- For decking boards over 150mm wide the gap may be increased to maximum of 10mm. Where the gap exceeds 8mm the boards shall run transverse to the direction of travel.

Compliance	Complies with spatial requirements
Comments	

Requirement

Accessway is required through:

- Principal pedestrian entry; and
- Not less than 50% of all pedestrian entrances; and
- In building with floor area over 500m², a non-accessible entry must not be located more than 50M from an accessible entry.

Compliance	Complies
Comments	

Requirement

All common use doorways to comply with AS1428.1 and the below requirements

Where accessible pedestrian entry has Multiple doorways:

- At least 1 to be accessible if 3 provided
- At least 50% to be accessible, if more than 3 provided
- Where doorway has multiple leaves, at least 1 leaf is to have clear opening of 850mm (excluding automatic doors)

Doorway requirements

- All common use doorways in the development within accessible path of travel (other than doorways non-accessible sanitary facilities) to have a clear opening of at least 850mm with appropriate door circulation spaces in accordance with AS1428.1. In case of multiple leaf doorways, at least 1 operable leaf is required to provide a clear opening of 850mm with the door circulations spaces as per AS1428.1.
- Ambulant toilet cubicle door to have a clear door opening of 700mm.
- Space required for door circulation spaces to have a maximum floor grade of 1:40 (doorway threshold ramps are permitted within the circulation space).
- Door thresholds are to be level, or they can incorporate a doorway threshold ramp with a maximum grade of 1:8, for maximum rise of 35mm and a maximum length of 280mm and located within 20mm of the door leaf, with edges to be tapered or splayed at a minimum of 45° where it does not abut a wall.
- Sliding doorways to be provided with recessed floor tracks to enable flush transition from the inside of the building.
- Distance between successive doorways in airlocks to be 1450mm which is measured when the door is in open position in case of swinging doors.
- Door hardware including door handles, door closers and the in-use indicators / snibs in accessible and ambulant toilets are required to comply with requirements of AS1428.1
- Luminance contrast requirements to doorways and other glazed areas to comply with AS1428.1
- Door reveals depth to be maximum of 300mm to the door face.
- Apart from main entry door and doors to any accessible toilets, the door handle height requirements can be varied if required for Childcare centres, swimming pool barriers or similar situations where the location of the opening and locking controls is prescribed by the relevant statutory authority.

Glazed viewing panels in doorway requirements (where compliance is required with AS1428.1-2021)

- Glazed viewing panels in doors to be as per AS1288
- The lower edge of the glazing should be no more than 1000 mm above FFL
- The upper edge of the glazing should be not less than 1600 mm above FFL
- In width, the glazing should extend to within not more than 200 mm from the latch edge of the door and be not less than 150 mm wide.

Compliance

Complies

Comments

Note: For Platinum Level units (Livable Housing Design Guidelines) all common use doorways and doorways within the unit are to provide for 900mm clear opening and door circulation spaces as applicable to 900mm clear doorways as per AS1428.1 in lieu of 850mm clear doorways

Details to be verified at the CC stage of works.

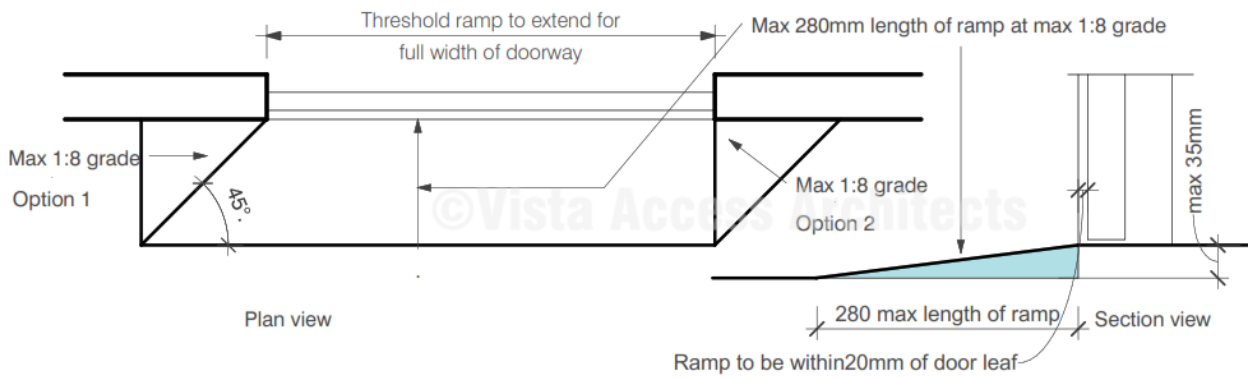

[Image description: Diagram showing requirements for door circulation spaces and door threshold requirements as per AS1428.1]

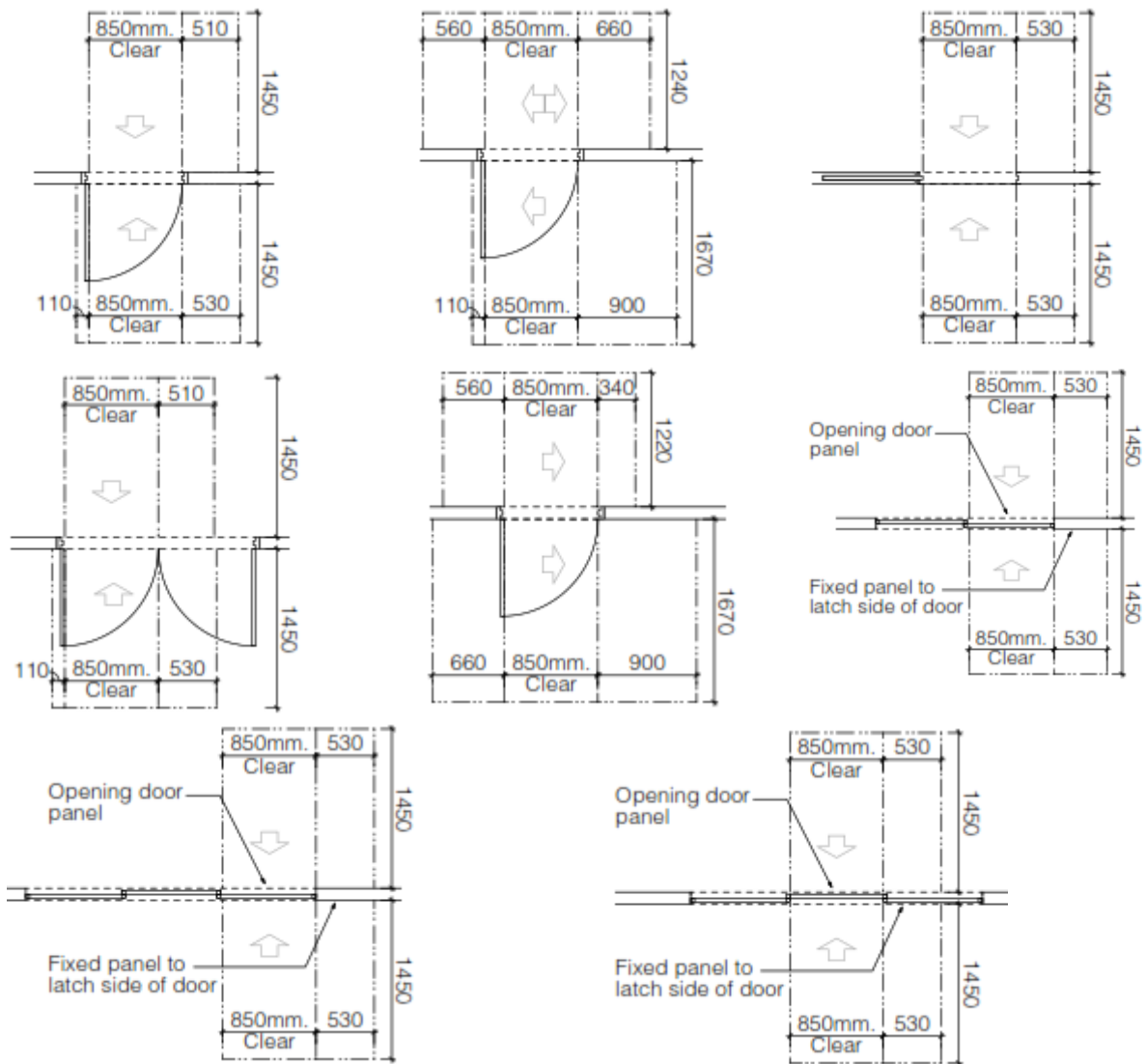

[Image description: Diagram showing requirements for door circulation spaces and door threshold requirements as per AS1428.1 for clear opening of 850mm]

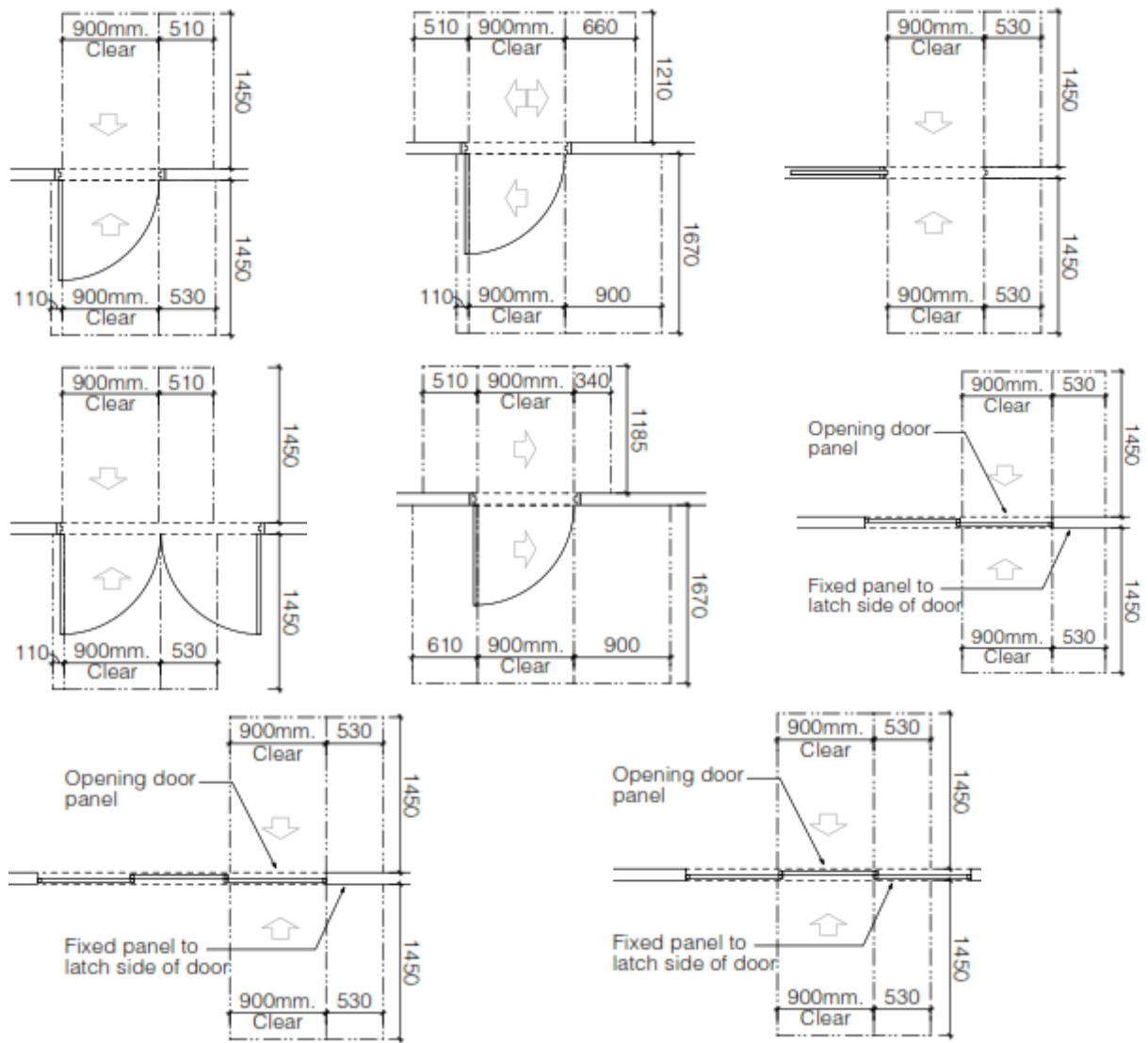

[Image description: Diagram showing requirements for door circulation spaces and door threshold requirements as per AS1428.1 for clear opening 900mm applicable where the Dwelling also needs to comply with LHA Platinum Level]

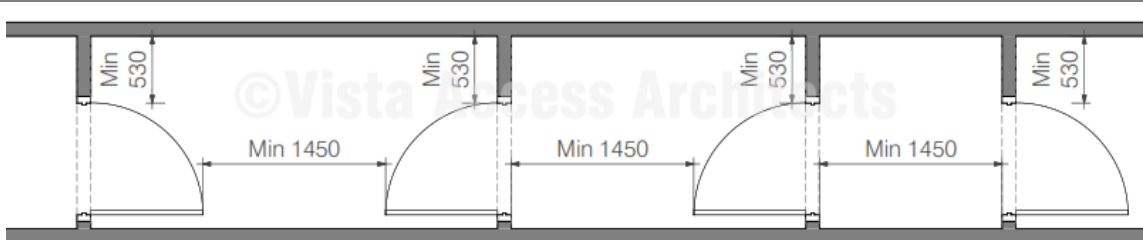

Distances in between airlocks to provide for a minimum 1450mm clear of door swing and minimum latch side space as shown in following diagram.

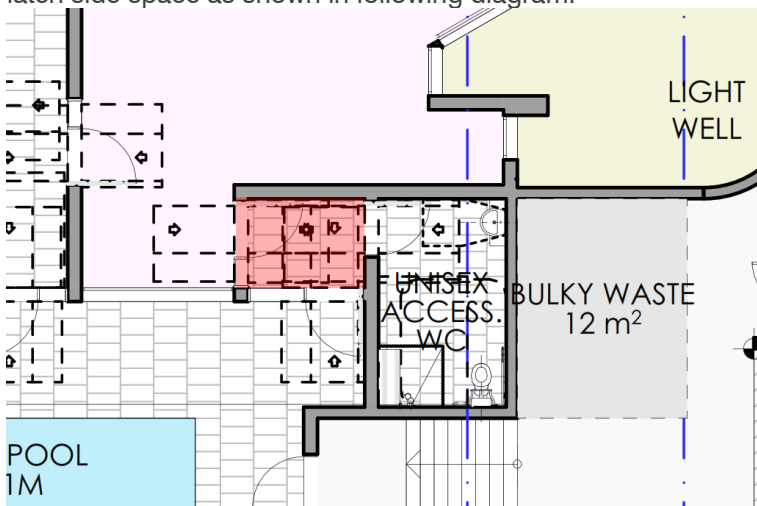

At CC stage the airlock from the pool area to the accessible bathroom will need to be detailed in full to show the required spaces between doorways.

[Image description: Circulation spaces required in airlocks in a required accessible path of travel]

BCA 2022 Part D4D4 Parts of buildings required to be accessible

Requirement

Every common use **Ramp** with grades steeper than 1:20 and less than or equal to 1:14 (excluding fire-isolated ramp) is to be compliant with AS1428.1, including (but not limited to):

- Maximum gradient of 1:14 with 1.2M flat landings at top, bottom and at maximum 9M of ramp and appropriate turning spaces as required by AS1428.1.
- 1M clear width to be provided between handrails / kerb / kerbrails. (curved ramps to be min 1.5M width between handrails / kerb / kerbrails with crossfall towards the centre of curvature) and located at height between 865mm-1000mm above FFL (finished floor level).
- AS1428 compliant handrails and kerbs to be provided on both sides with appropriate extensions

Compliance

Capable of compliance

Comments

Where this type of ramp is provided, the details of the ramp will be assessed with the relevant requirements of AS1428.1 at the CC stage of works.

At CC stage, Handrails is required to both sides of the ramp and min 1200mm clear handrail to handrail to be provided and shown on plans.

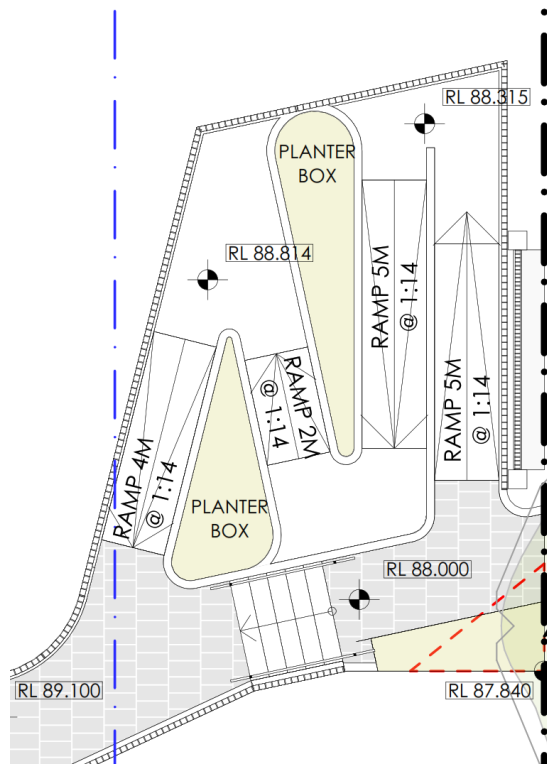

Requirement

Step ramp if provided in common use areas is to be compliant with AS1428.1 and NCC/BCA

Compliance N/A

Comments

This type of ramp has not been identified in the development.

Requirement

- **Kerb ramp** if provided in common use areas is to be compliant with AS1428.1

Compliance N/A

Comments

This type of ramp has not been identified in the development.

Requirement

Every **Stairway** in common use areas (excluding fire-isolated stairway) is to be compliant with AS1428.1 including;

- Handrails to be provided on both sides with 1M clearance between them and located at consistent height, between 865mm-1000mm above FFL, with no vertical sections.
- Either provide handrail extensions or offset first riser going up at mid landings
- Opaque risers required with nosing to have a sharp intersection or rounded or chamfered to 5mm.
- Handrails to extend a minimum of 300mm horizontally past the nosing on the top riser. At the bottom of the stairs the handrail is to extend at least one tread depth parallel to the line of the nosing, plus a minimum of 300mm horizontally from the last riser.

Comments

Where this type of stairway is provided, the details of the stairway will be assessed with the relevant requirements of AS1428.1 at the CC stage of works.

Note: In some cases, the stairway from the basement to the ground floor level is considered to be non-fire-isolated, in which case full compliance will be required as per AS1428.1. Verify with the BCA consultant if this is the case.

Note: For stairways with 90° to 180° turns at landings, in order for the handrails to comply with the consistent height requirement, the risers have to be offset at the mid-landings so that no vertical sections are created in the handrails. This applies to both non-fire-isolated and fire-isolated stairways.

Handrails and extensions to be detailed at CC stage for all non-fire isolated stairways.

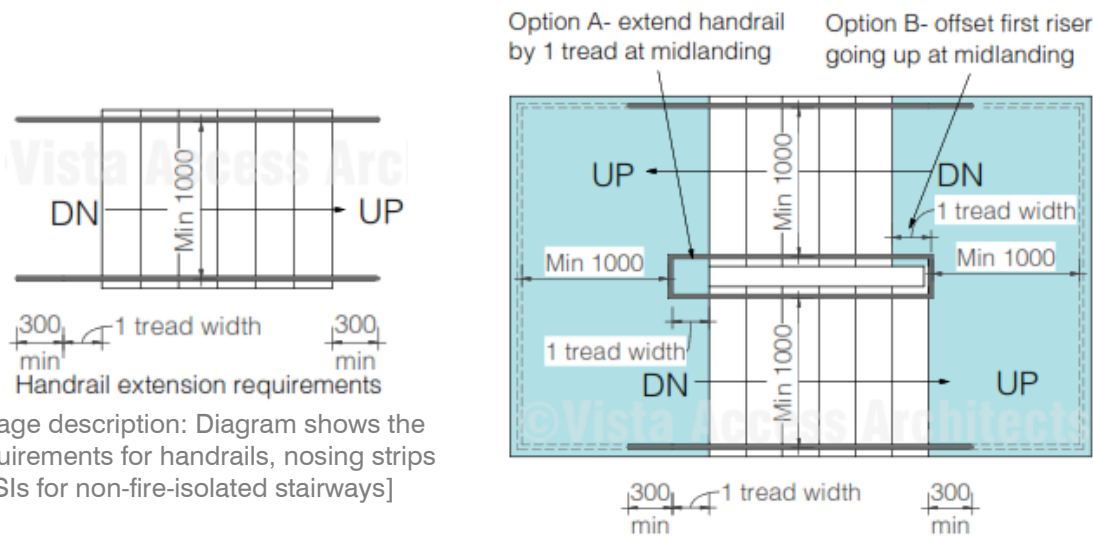

[Image description: Diagram shows the requirements for handrails, nosing strips TGSIs for non-fire-isolated stairways]

and

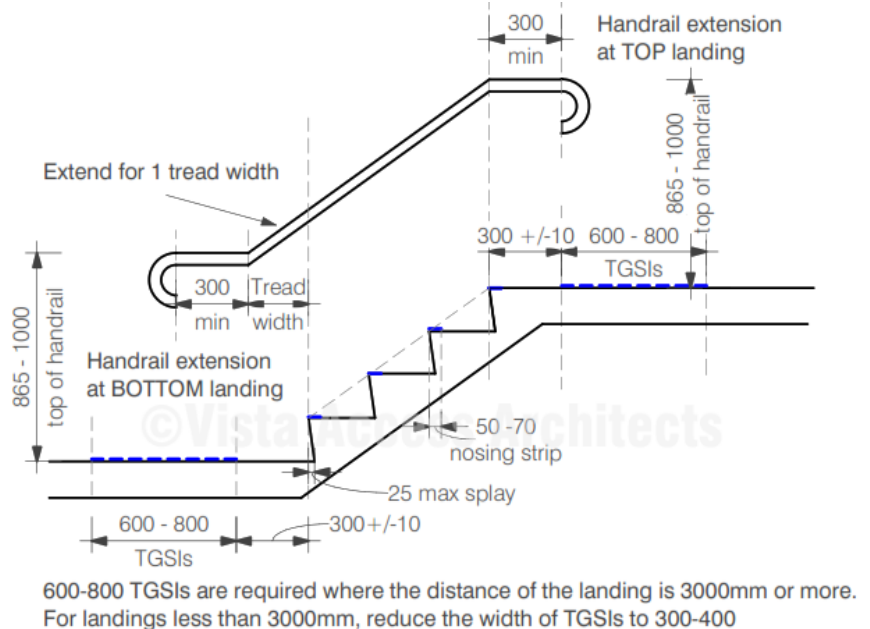

Requirement

Every **Fire-isolated Stairway** is to be compliant with AS1428.1 in the following aspects:

- Handrails to be provided only on one side of the staircase with 1M clear width and located between 865-1000mm above FFL. Handrail extensions are not required however since the handrails cannot have any vertical sections and is required to be at a consistent height throughout the stairway, it may be essential to either provide handrail extensions or offset first riser going up at mid landings
- Opaque risers required with nosing to have a sharp intersection or rounded or chamfered to 5mm.
- Handrails to both sides of the stairway are required if the total width of the stairway is 2M or more.

Compliance Complies with spatial requirements

Comments

Where this type of stairway is provided, the details of the stairway will be assessed with the relevant requirements of AS1428.1 at the CC stage of works.

Handrails to both sides are not required, however the internal handrail is to be continuous and to comply with all requirements of non-fire-isolated stairways.

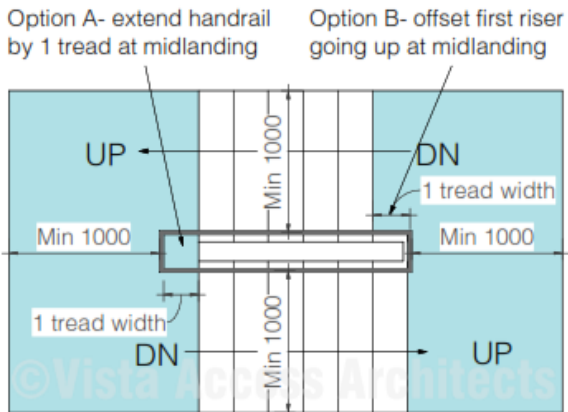

Requirement

Handrail requirements at mid landings

Option A- Handrails to extend a minimum of 300mm horizontally past the nosing

Option B- Handrail to extend at least one tread depth parallel to the landing before turning

Compliance Complies with spatial requirements

Comments

Details to be verified at CC stage of works.

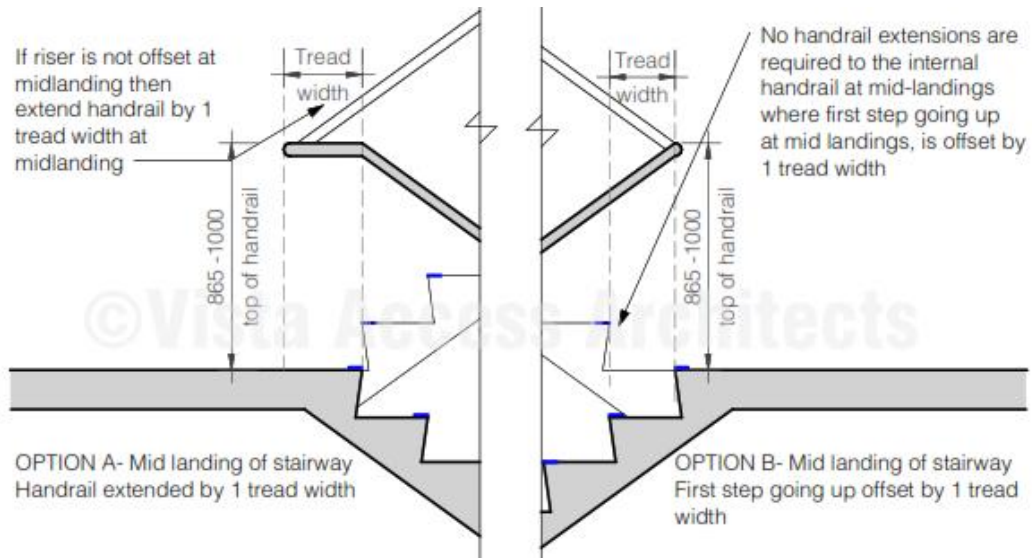

[Image description: Diagram shows the requirements for handrails at mid landings of both fire-isolated and non-fire-isolated stairways]

Requirement

Nosing for common use fire-isolated and non-fire-isolated stairways to comply with AS1428.1

Compliance Capable of compliance

Comments

Detailed features of the nosing strips will be assessed with the requirements of AS1428.1 at the CC stage of works.

Requirement

Slip resistance to comply with **BCA 2022, Table D3D15** and **AS2890.6** when tested in accordance with **AS4586** and **AS4663**

BCA 2022 Table D3D15 Slip –resistance requirements when tested in accordance with AS4586:

Application (common use areas)	Surface conditions	
	Dry	Wet
Ramp (and accessways to accessible parking spaces) steeper than 1:14	P4 or R11	P5 or R12
Ramp steeper than 1:20 but not steeper than 1:14	P3 or R10	P4 or R11
Accessways to accessible parking spaces not steeper than 1:14	P3 or R10	P4 or R11
Tread or landing surface for ramps and stairways	P3 or R10	P4 or R11
Nosing or landing edge strip	P3	P4
Accessible parking spaces and shared areas	P3 or R10	P4 or R11

HB 197/ HB198 An introductory guide to the slip resistance of pedestrian surface materials provides guidelines for the selection of slip-resistant pedestrian surfaces

Compliance Capable of compliance

Comments

For Slip resistance of surfaces the builder is required to provide a Certificate stating that the Slip resistance of the surfaces comply with the above listed requirements when tested as per AS4586 at CC stage of works.

Requirement

Every **Passenger lift** is to comply with the requirements of [BCA 2022, E3D7](#).

Compliance Capable of compliance

Comments

This has been assessed further in the report in the Lifts section. Refer to Lifts section.

Requirement

Passing spaces requirement

It is a requirement to provide passing spaces in common use accessways complying with AS1428.1 at maximum 20 M intervals, where a direct line of sight is not available. Space required is 1800x2800mm (in the direction of travel). Chamfer of 400x400mm is permitted at corners.

Compliance N/A

Comments

There are no accessways over 20M lengths in the development where a direct line of sight is not available

Requirement

Turning spaces requirement

It is a requirement to provide turning spaces in common use accessways complying with AS1428.1 within 2M of the end of accessways where it is not possible to continue travelling and at every 20M intervals. CLEAR Space required is 1540mmx2070mm in the direction of travel (measured from skirting to skirting).

Compliance Complies with spatial requirements

Comments

- Adequate turning spaces have been provided with minimum common use passageway widths being 1540mm clear or alternatively a space of 1540mmx2070mm provided at or within 2M of the end of the passageway.
- Where the passageway is more than 20M long and therefore a space of 1540mmx2070mm provided at maximum 20M intervals. Pathway from Russell Avenue to be assessed at CC stage to determine of a turning space is required every 20m
- A space of 1540mmx2070mm is also required / provided in front of all passenger lift doors.
- A space of 1540mmx2070mm is also required / provided in front of common use letterboxes

Within 2m of the end of a passageway, a 1540x2070mm turning space is to be provided and shown at CC stage sample provided for ground floor but applicable to all levels with common pathways and corridors.

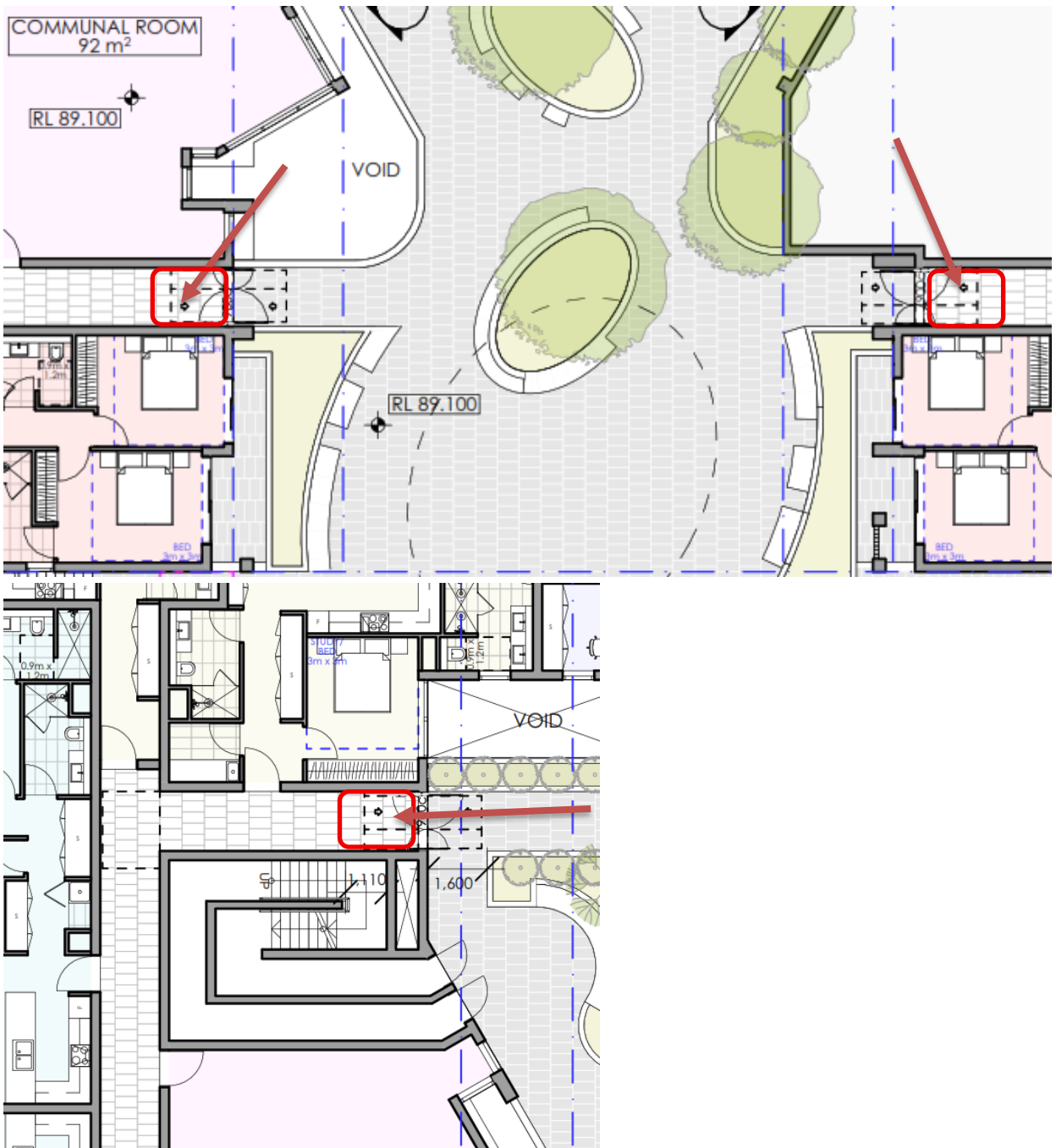

Details to be verified at CC stage of works.

Requirement

Carpets, when provided in common use areas or areas with accessible SOUs to comply with AS1428.1

Compliance N/A

Comments

Use of carpets have not been identified in the common use areas

BCA 2022 Part D4D5 Exemption

Requirement

Access is not required to be provided in the following areas:

- Where access would be inappropriate because of the use of the area
- Where area would pose a health and safety risk
- Any path which exclusively provides access to an exempted area

Compliance For information only

Comments

Areas such as lift machine rooms, fire services room, commercial kitchens, areas in childcare centres such as nappy change room or cot rooms etc or exclusive staff use areas in storage facilities. in the development are exempted from providing access under this clause due to WHS concerns.

Where a caretaker is provided in the development, the toilet provided exclusively for use by the caretaker can be excluded from providing access based on the provisions in this clause.

BCA 2022 Part D4D6 Accessible Carparking

Requirement

Class 2

There are no Accessible carparking requirements for a Class 2 under the BCA.

If adaptable housing has been mandated by the Council, then carparking spaces for Adaptable units will be required under the requirements of AS4299- Adaptable housing.

Compliance Complies

Comments

Ku-ring-gai Council requires provision of 15 Platinum Level units in the development and in accordance with the DCP each platinum level unit is to be provided with a compliant AS2890.6 parking space. Therefore, 15 x accessible carparking spaces are required for the residential component of the development.

15 x Accessible car parking spaces have been provided in development.

One accessible parking space is required to be allocated to each of the Platinum units.

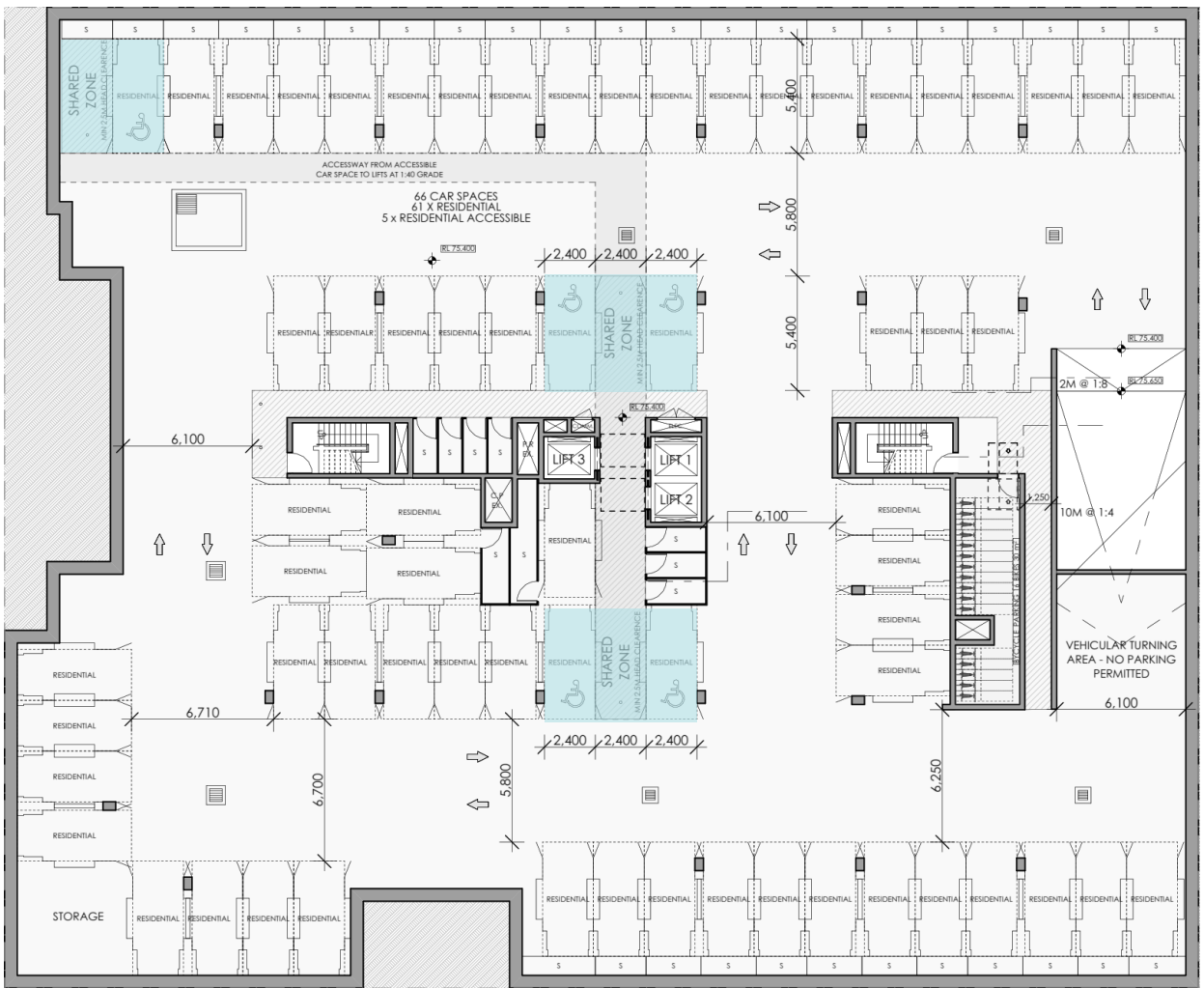

Basement 3

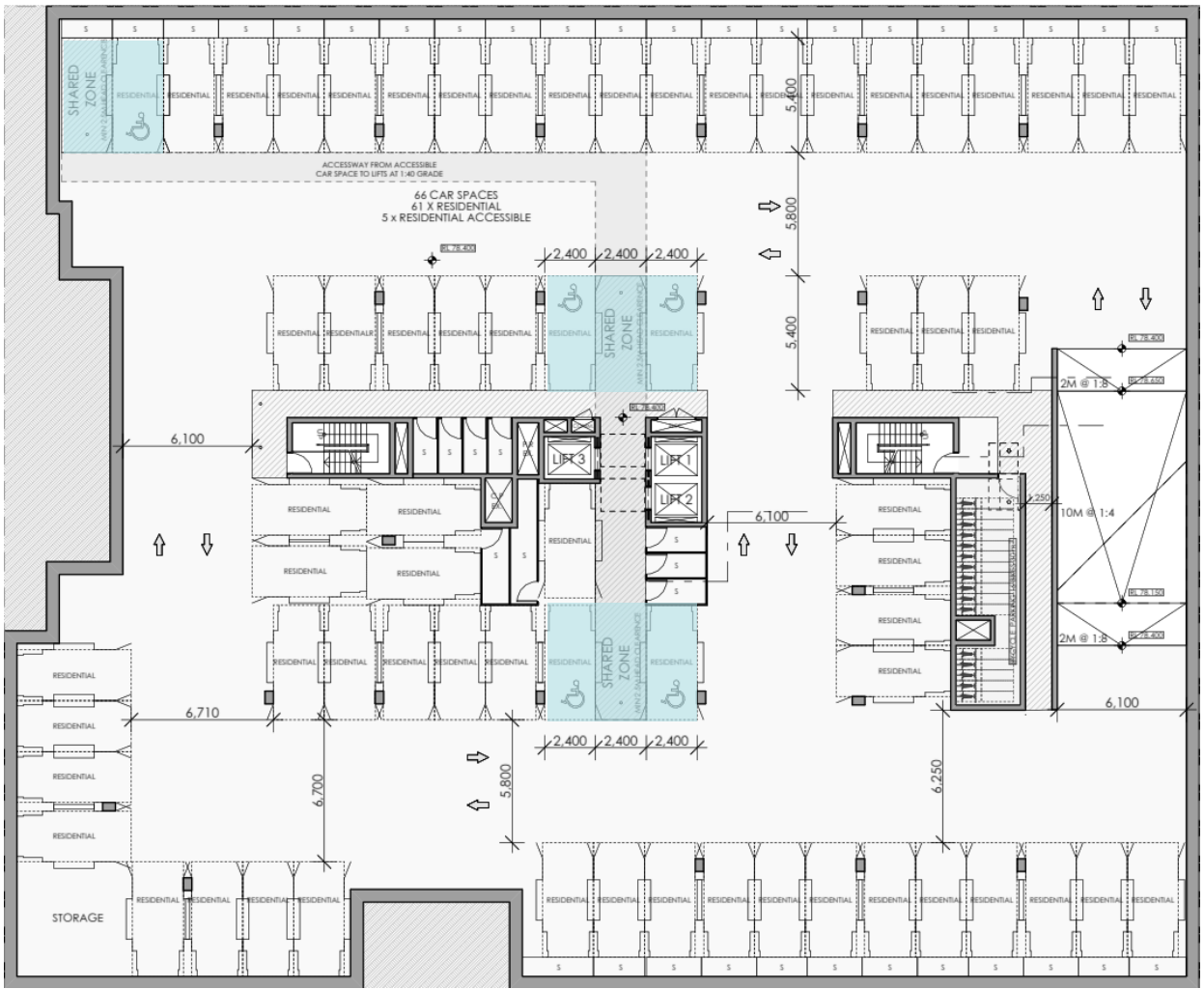

Basement 2

AS2890.6-2009 requirements for Accessible car parking space

Requirement

Angle Parking AS 2890.6-2009

- Dedicated space 2.4Mx5.4M, Shared space 2.4Mx5.4M at the same level
- Slip resistant flooring surface with maximum fall 1:40 in any direction or maximum 1:33 if bituminous and outdoors.
- Central Bollard in shared space at 800+/-50mm from entry point.
- Pavement marking in dedicated space by means of access symbol between 800mm-1000mm high placed on a blue rectangle of maximum 1200mm and between 500mm-600mm from its entry point (marking is not to be provided where the space is allocated to an Adaptable unit).
- Minimum headroom of 2.2M at entrances and 2.5M is required over shared space as well as dedicated spaces.
- Non-trafficked area of the shared space to have yellow marking strips at 45°, 150-200mm wide at 200mm-300mm spaces (not required where driveways are used as shared spaces)
- Accessible parking spaces, shared areas and the pavement marking shall have slip resistance of P3/R10 in dry and P4/R11 in wet conditions.

Compliance

Complies with spatial requirements

Comments

Details to be verified at CC stage of works.

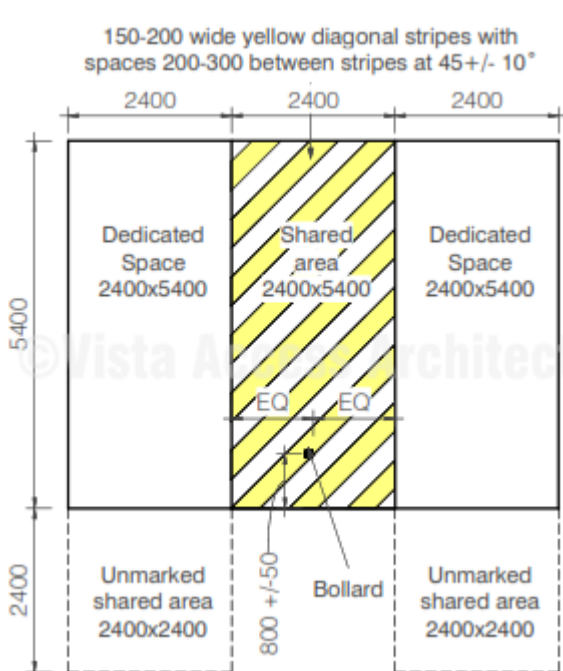
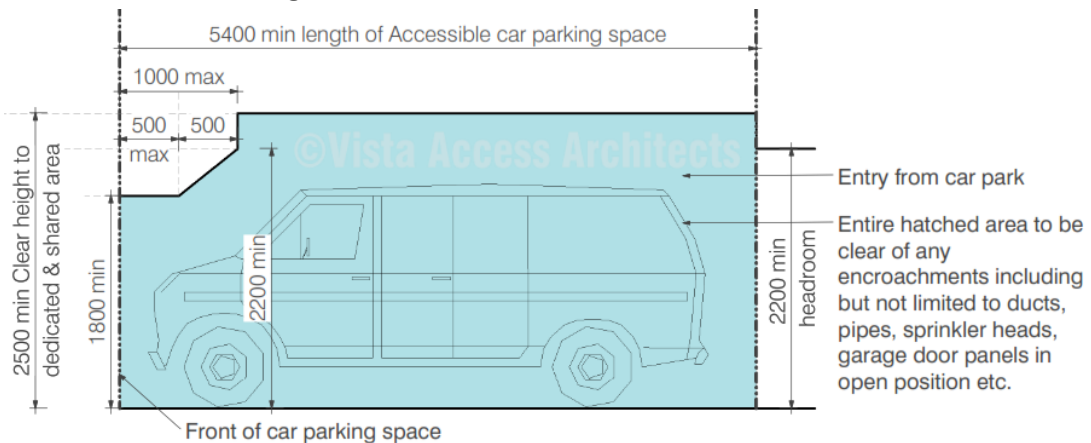

[Image description: Diagram showing spatial requirements of AS2890.6-2009 including line marking and bollard requirements]

Access symbol is not to be provided when spaces are allocated to a particular residential unit.

Additional recommendations as per AS2890.6-2022 (not currently mandatory):

Dedicated Bollard to have a height of minimum 1300mm with a minimum 300mm retro-reflective colour band, located at minimum 900mm in height above car parking floor that provides minimum 30% luminance contrast to the pavement.

BCA 2022 Part D4D7 Signage

Requirement

Braille and Tactile signage are required to identify Accessible Sanitary facilities

Compliance N/A

Comments

No common use sanitary facilities have been identified in the development.

Requirement

Braille and Tactile signage are required immediately outside an airlock or doorway that leads to separate male, female and accessible toilets.

Compliance N/A

Comments

No common use sanitary facilities have been identified in the development.

Requirement

Braille and Tactile signage are required to identify Ambulant Sanitary facilities

Compliance N/A

Comments

No ambulant sanitary facilities have been identified in the development.

Requirement

Braille and Tactile signage is required to identify Hearing Augmentation

Compliance N/A

Comments

Hearing augmentation is not provided since there is no inbuilt amplification system identified in the development.

Requirement

Braille and Tactile signage is required to identify a Fire exit door required by [BCA2022, E4D2](#) by stating the 'Exit' and 'Level', followed by either the floor level number or floor level descriptor or a combination of both of the above and located on the side that faces a person seeking egress

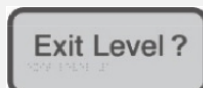

[Image description: Image of Signage The "?" shown in image is to be replaced with the floor level where the door is located]

Compliance Capable of compliance

Comments

Signage selections generally take place at CC stage of works. Selection and location of signage as specified above will lead to compliance. Details of selected signage to be verified at CC stage of works.

Requirement



Signage is required to a non-accessible pedestrian entrance

to direct to the nearest accessible pedestrian entry.

[Image description: Image of directional Signage]

Arrow direction on this signage is indicative only and the direction of the arrow will be based on the location of the accessible entry.

Compliance Capable of compliance

Comments

Signage selections generally take place at CC stage of works. Selection and location of signage as specified above will lead to compliance. Details of selected signage to be verified at CC stage of works.

Requirement

Signage is required where a bank of sanitary facilities is not provided with an accessible unisex sanitary facility.

Compliance N/A

Comments

N/A

Requirement

Signage is required to a single hand pushing action device (example manual control button to an automated doorway) where the latch operation device is not located on the door leaf itself

Compliance Capable of compliance

Comments

No automated doors have been identified on the plans.

Requirement

Directional signage complying with [BCA 2022 Specification 15](#) must be provided at the location of each—

- i. bank of sanitary facilities; and
- ii. accessible unisex sanitary facility, other than one that incorporates an accessible adult change facility, to direct a person to the location of the nearest accessible adult change facility within that building.



Arrow is indicative only and needs to point in the direction of the accessible toilet on side

Compliance N/A

Comments

N/A

Requirement

All signage is required to be as per BCA 2022 Specification 15 Braille and Tactile Signs
This includes location of signage, specifications in regard to braille and tactile characters, luminance contrast and lighting.

Compliance Capable of compliance

Comments

Signage selections generally take place at CC stage of works. Selection and location of signage as specified above will lead to compliance. Details of selected signage to be verified at CC stage of works.

BCA 2022 Part D4D8 Hearing Augmentation

Requirement

Hearing Augmentation is only required where an inbuilt amplification system (other than emergency) is installed in a Class 9b building, or in an auditorium, conference / meeting room or a reception area where a screen is used.

Compliance N/A

Comments

No areas with provision of inbuilt amplification have been identified on plans and hence no hearing augmentation requirements apply to this development.

BCA 2022 Part D4D9 Tactile ground surface indicators (TGSIs)

Requirement

TGSIs are required when approaching:

- Stairways other than fire-isolated stairways.
- Escalators / passenger conveyer / moving walk.
- Ramp (other than fire-isolated ramps / kerb or step or swimming pool ramps).
- Under an overhead obstruction of <2M if no barrier is provided.
- When accessway meets a vehicular way adjacent to a pedestrian entry (if no kerb / kerb ramp provided at the location).

Compliance is required with AS1428.4.1 including Luminance contrast and slip resistance requirements for all TGSIs.

Compliance Capable of compliance

Comments

TGSI selections generally take place at CC stage of works. Selection of TGSIs as specified will lead to compliance and these selection details are to be verified at CC stage of works.

BCA 2022 Part D4D11 Class 10b - Swimming pools

Requirement

Access to a **pool with a perimeter >40M** to be by one of the following means;

- Fixed or movable ramp and an aquatic wheelchair
- Zero depth entry with 1:14 grade and an aquatic wheelchair
- Platform swimming pool lift and an aquatic wheelchair
- A sling style pool lift

Compliance N/A

Comments

The perimeter of the swimming pool is less than 40M.

Requirement

Access to a **pool with a perimeter >70M** cannot choose to use a sling style pool lift as the sole means of entry.

Compliance N/A

Comments

The perimeter of the swimming pool is less than 70M.

Requirement

Latching devices on gates and doors of the swimming pool safety barrier are not required to comply with AS1428.1.

Compliance For information only

Comments

For information only

BCA 2022 Part D4D12 Limitations on Ramps

Requirement

On an accessway:

- A series of connected ramps must not have a combined vertical rise of more than 3.6M;
- And a landing for a step ramp must not overlap a landing for another step ramp or ramp.

Compliance Capable of compliance

Comments

Compliance is met Full spatial requirements and fixtures to be detailed at CC stage

BCA 2022 Part D4D13 Glazing on Accessways

Requirement

Glazing requirements:

- Where there is no chair rail, handrail or transom, all frameless or fully glazed doors, sidelights and any glazing capable of being mistaken for a doorway or opening are required to have a glazing strip
- The marking should be for the full width with a solid and non-transparent 75mm wide, contrasting line located 900-1000mm above FFL and provide a minimum luminance contrast of 30% when viewed against the floor surface within 2M of the glazing on the opposite end. Graphical representation or cut-outs are not permitted.

Compliance

Capable of compliance

Comments

Glazing strips are required to be provided to full height glazed areas (doors and windows) used in common use areas such as lift lobbies and common passageways

Glazing strip selections generally take place at CC stage of works. Selection of glazing strips as specified above will lead to compliance and details are to be verified at CC stage of works.

BCA Part F Accessible Sanitary Facilities

BCA 2022 Part F4D5 Accessible Sanitary facilities

Requirement

Accessible unisex toilet is to be provided in accessible part of building such that;

- It can be entered without crossing an area reserved for 1 sex only
- Where male and female sanitary facilities are provided at different locations, Accessible unisex toilet is only required at one of the locations
- Even distribution of LH and RH facilities
- An accessible facility is not required on a level with no lift / ramp access.

Compliance

Complies

Comments

1 unisex accessible toilet has been identified in the development.

BCA 2022 Part F4D6 Accessible unisex sanitary compartments

Requirement

Class 2

At least 1 unisex Accessible toilet when sanitary compartments are provided in common areas.

Compliance

Complies

Comments

1 unisex accessible toilet with an accessible shower has been identified in the development within the pool area.

BCA 2022 Part F4D7 Requirements for Accessible unisex showers

Requirement

Class 2

At least 1 unisex Accessible shower when showers are provided in common areas.

Compliance Complies

Comments

1 unisex accessible toilet with an accessible shower has been identified in the development within the pool area.

Requirement

Accessible unisex toilet is to be designed in accordance with AS1428.1

Compliance Capable of compliance

Comments

Detailed features of the accesible toilet will be assessed at the CC stage of works

Requirement

Showers for Accessible use are to be designed in accordance with AS1428.1

Compliance Capable of compliance

Comments

Detailed features of the Accessible shower will be assessed at the CC stage of works

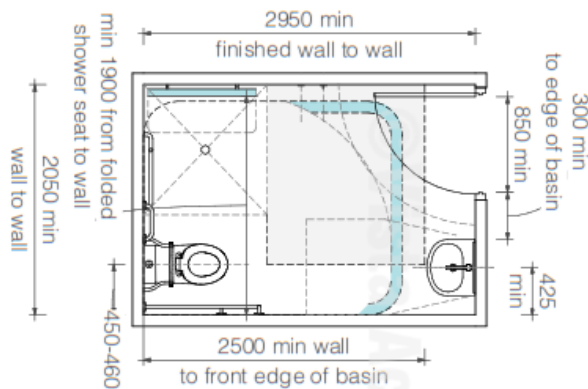

Requirement

Ambulant use male / female toilets are to be provided if an additional toilet to the Accessible unisex toilet is provided

Compliance N/A

Comments

No ambulant toilet facilities have been identified in the development

BCA Part E Lift Installations

BCA 2022 Part E3D3 Stretcher facility in lifts

Requirement

A **Stretcher lift** is to be provided if a passenger lift is installed to serve any storey with an effective height of 12M. The space requirement is 600mm wide x 2000mm deep x 1400mm high above the floor level. Confirm this requirement with your BCA consultant.

Compliance For information only

Comments

Contact BCA consultant in regard to applicable requirements.

BCA 2022 Part E3D7 Passenger lift and their limitations

Requirement

In an accessible building, **Every Passenger Lift** (excluding electric passenger lift, electrohydraulic passenger lift, inclined lift) must be subject to limitations on use and must comply with **BCA 2022, E3D7, E3D8 and E3D10**

Compliance Capable of compliance

Comments

A certificate of compliance from the lift supplier, stating that the proposed lift complies with the requirements of BCA Part E3- Lift installations will be required at the CC stage of works

Limitations on use of types of passenger lifts

Requirement

Limitations on use of Stairway platform lifts, Low-rise platform lift, Low-rise, low-speed constant pressure lift and small sized, low-speed automatic lift

Compliance N/A

Comments

This type of lift has not been identified in the development.

BCA 2022 Part E3D8 Accessible features required for passenger lifts

Requirement

Handrail requirements for passenger lifts. Apart from stairway platform lift and low-rise lifts, a handrail is required as per AS1735.12:

- 600mm minimum handrail not more than 500mm from control panel
- Top of handrail between 850-950mm above FFL
- Diameter of handrails to be between 30-50mm and located not less than 50mm from adjacent walls with no obstructions to top 270° arc

Lift floor dimensions (excluding stairway platform lift)

- Lifts traveling **12M** or under, floor size, **1100mm wide x 1400mm deep**
- Lifts travelling **more than 12M**, floor size **1400mm wide x 1600mm deep**
- If lift doors are on adjacent sides of the lift on different floor levels, then the, lift floor size is required to be 1400x1600 or 1500x1500 to allow for a wheel\chair to make a 90 degree turn in the lift.

Minimum **Door opening size** complying with AS1735.12, not less than 900mm clear (excluding stairway platform lift).

All lifts with a power operated door are required to have a **Passenger protection system** complying with AS1735.12.

Lift landing doors to be provided at upper landing (excluding stairway platform lift).

Lift car and landing control buttons complying with AS1735.12

Some of the requirements listed below. Refer to AS1735.12 for further details.

For internal control panel:

- If width or depth of car is less than 1400mm, 2 control panels to be provided, one to the left and one to the right of the person entering the car
- Tactile symbol and Braille equivalent to be provided
- Buttons to be located between 900-1100mm above FFL
- All buttons to be 300mm from corner (near entry) and 400mm of all other corners

For external control panel:

To be located between 900-1100mm above FFL and not less than 500mm from internal corners unless otherwise permitted by AS1735.12

Lighting (for all enclosed lift cars) to be provided in accordance with AS1735.12 and AS1680. Minimum illuminance of 100 lx is required at the level of the car floor and average of 50 lx is required on the control panel surface.

To all lifts serving more than 2 levels

- Automatic audible information to identify level when car stops
- Audible and visual indication at landing to indicate arrival of lift car

Audible information and indication to be provided between 20-80 dB(A) at a maximum frequency of 1500Hz

Emergency hands free communication (excluding stairway platform lift) – provide a button that alerts a call centre and a light that the call has been received.

Compliance

Complies

Comments

A certificate of compliance from the lift supplier, stating that the proposed lift complies with the requirements of BCA Part E3- Lift installations will be required at the CC stage of works

State Environmental Planning (Housing) 2021 (previously known as SEPP 65), Clause 43C requires consideration of the Apartment Design Guide (ADG) as noted below

43C Consideration of design of residential apartment development
 Before carrying out residential apartment development to which this division applies, the relevant authority must consider the following—
 (a) the quality of the design of the development, evaluated in accordance with the design principles for residential apartment development set out in Schedule 9,
 (b) the Apartment Design Guide.

ADG Chapter 4, Objective 4Q1, notes the requirement of 20% of the units to comply with Livable Housing Australia’s Silver Level as noted below

SEPP Housing 2021- Chapter 4 Apartment Design Guide

Part 4Q1 of Apartment Design Guide Objective 4Q-1 Universal Design

Objectives	Design guidance
<p>Objective 4Q-1 Universal design features are included in apartment design to promote flexible housing for all community members</p>	<p>Developments achieve a benchmark of 20% of the total apartments incorporating the Livable Housing Guideline's silver level universal design features</p>

DCP requires 15 of the units to LHA platinum level and the remainder 84 units to LHA Silver level.

In addition to the platinum level units provided the remaining **84** units within the development is capable of providing compliance with the features of Silver level of Livable Housing Guidelines as noted in the table below.

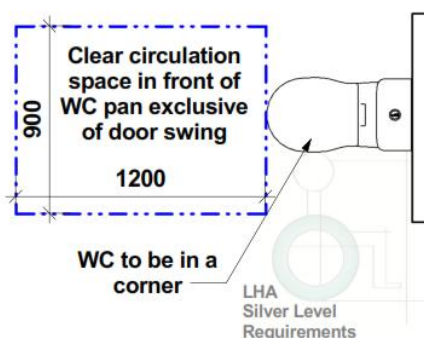

By incorporating the requirements of the below Checklist in the Specifications of the project, the nominated Livable units can achieve full compliance with Livable Housing Guidelines- Silver Level

- For units 801, 802, 803, 804, 805 806 and 807 the internal stairway leading to the provide roof terrace will require a handrail to be provided to at least one side at CC stage.

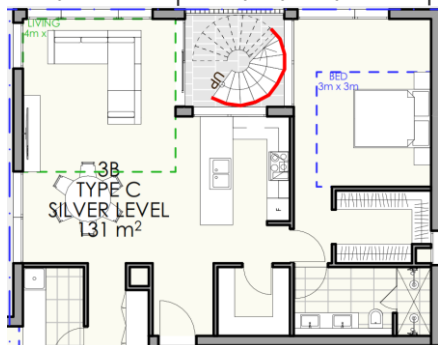

All details to be verified at the CC stage

Design Element	Requirements (All dimensions noted are required to be clear of finishes as required under AS1428.1)	Compliance /Comments
1 Dwelling Access	<ul style="list-style-type: none"> a. Provide a safe and continuous 1M clear width pathway from front site boundary to an entry door to the dwelling. b. Path including any ramps and walkways to have no steps, even firm, slip-resistant surface, max 1:40 crossfall, max slope of 1:14 with landings of 1.2M every 9M and landings every 15M for 1:20 walkways. 1M clear width of ramps are required. c. Pathway may be provided via an associated car parking in which case the car parking space to be <ul style="list-style-type: none"> ▪ 3200 (width) x5400 (length), ▪ even, firm and slip resistant, level surface of 1:40 max grade and 1:33 max grade for bitumen d. Step ramp may be provided at an entrance doorway. The step ramp to be max 190mm height, max 1:10 grade, max 1900mm length. e. Level landings of 1200mm are required exclusive of the swing of the door or gate and to be provided at the head and foot of the ramp. 	<p>Complies. Details to be verified at CC stage of works</p> <p>N/A Access is provided from the site boundary.</p> <p>N/A</p> <p>N/A</p>
2 Dwelling entry	<ul style="list-style-type: none"> a. Dwelling Entry should provide an entrance door with <ul style="list-style-type: none"> i. min clear opening width of door to be 820mm ii. Step free threshold of max 5mm with rounded or beveled lip iii. reasonable shelter from the weather b. Level landing of 1200x1200mm at step-free entrance door on the arrival / external side of the entrance door. c. Max permissible threshold is less than 56mm where provided with a 1:8 grade threshold ramp. d. Entrance to be connected to a pathway (specified under Element 1) Note: The entrance to 	<p>Capable of compliance. Details to be verified at CC stage of works</p> <p>Complies with spatial requirements. Details to be verified at CC stage of works</p> <p>N/A</p> <p>Complies. Details to be verified at CC stage of</p>

incorporate waterproofing and termite management requirements as specified in the NCC

works Waterproofing compliance by others.

3

Internal doors and corridors

- a. Doors to rooms on the entry level used for living, dining, bedroom, bathroom, kitchen, laundry and sanitary compartments to be
 - i. 820mm clear opening and
 - ii. provided with a level threshold of max 5mm between abutting surfaces with rounded or beveled lip
- b. Internal corridors and passageways to doorway to be min 1M clear (measured from skirting to skirting)

Capable of compliance. Details to be verified at CC stage of works

Complies with spatial requirements. Details to be verified at CC stage of works

4

Toilet

- a. One Toilet to be provided on the ground or entry level that provides,
 - i. Min 900mm between walls or amenities
 - ii. Min 1200mm clear space in forward of the WC pan exclusive of door swing.
 - iii. The toilet pan to be positioned in the corner of a room to enable handrails

Capable of compliance. Details to be verified at CC stage of works

5

Shower

- a. One bathroom should feature a slip resistant, hobless shower recess. Shower screens are permitted provided they can be easily removed at a later date.
- b. The shower recess should be located in the corner of the room to enable the installation of grabrails at a future date.

Complies with spatial requirements. Details to be verified at CC stage of works

For hobless specification please see Australian Standard AS3740-3.6. Reinforcement guidelines for walls in bathrooms and toilets are found in element 6

6

Reinforcement of bathroom & toilet walls

- a. Except for walls constructed of solid masonry or concrete, the walls around the shower, bath (if provided) and toilet should be reinforced to provide a fixing surface for the safe installation of grabrails.
- (b), (c) and (d) the walls around toilet, bath and shower to be via:
 - i. Noggings with a thickness of at least 25mm
 - ii. Sheeting with a thickness of at least 12mm

Capable of compliance. Details to be verified at CC stage of works

Capable of compliance. Details to be verified at CC stage of works

Refer to diagrams provided in the Livable Housing Guideline document.

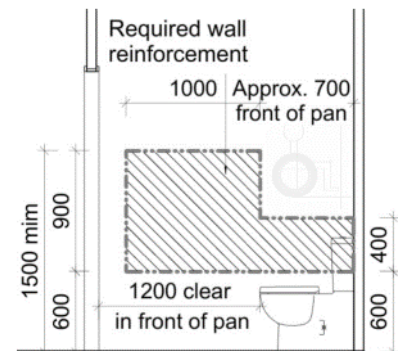
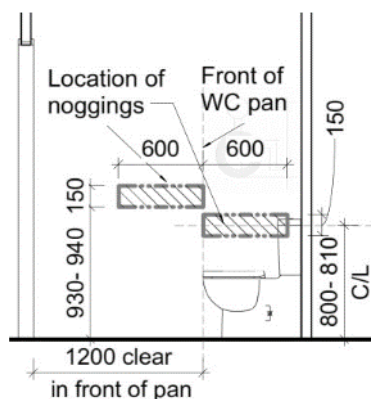
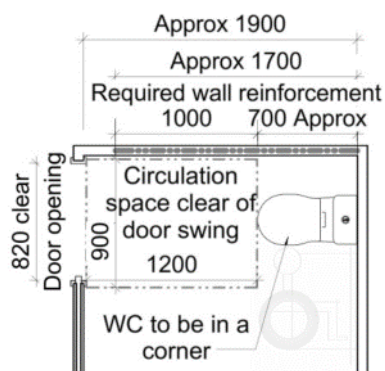

[Image description: Diagram shows wall reinforcements options of noggings or sheeting for a toilet]

Note: In a standalone toilet, the wall reinforcements are required to both sides. Any door openings/ door frames are required to be clear of the required wall reinforcements. If wall with cavity slider is used for wall reinforcements, then allow for additional thickness for the wall.

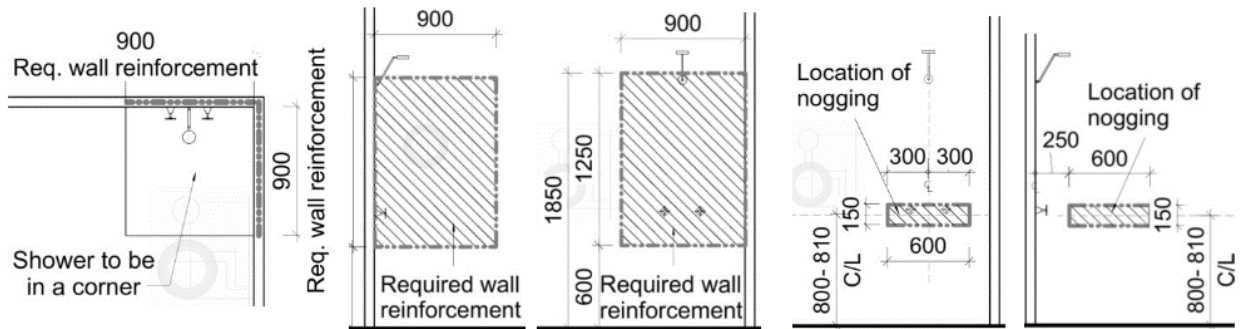

[Image description: Diagram shows wall reinforcements options of noggings or sheeting for a shower]

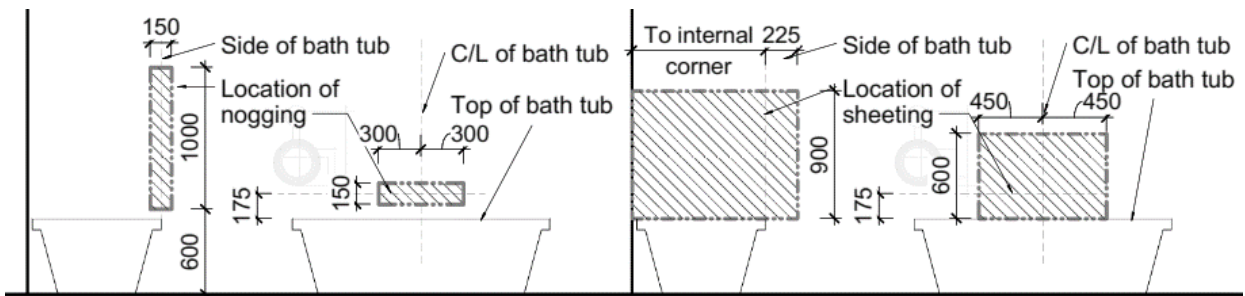

[Image description: Diagram shows wall reinforcements options of noggings or sheeting for a bathtub]

7

Internal Stairways

Stairways in dwellings must feature:

- a continuous handrail on one side of the stairway where there is a rise of more than 1M.

Capable of compliance

Platinum level Units

DCP requires 15% of the units to LHA platinum level and the remainder 85% units to LHA Silver level.

Total number of residential units in the development = 15% of 99 = 14.85 = **15** required Platinum level Livable units.

The units **LG01, LG02, LG04, LG05, LG06, LG07, LG08, 110, 112, 201, 214, 301, 314, 401 and 412** are capable of providing compliance with the features of Platinum level of Livable Housing Guidelines as noted in the table below.

By incorporating the requirements of the below Checklist in the Specifications of the project, the nominated Livable units can achieve full compliance with Livable Housing Guidelines- Platinum Level

At CC stage, the 1200x1200 WC circulation and shower circulation to be shown and dimensioned in all platinum units. Shown in red below.

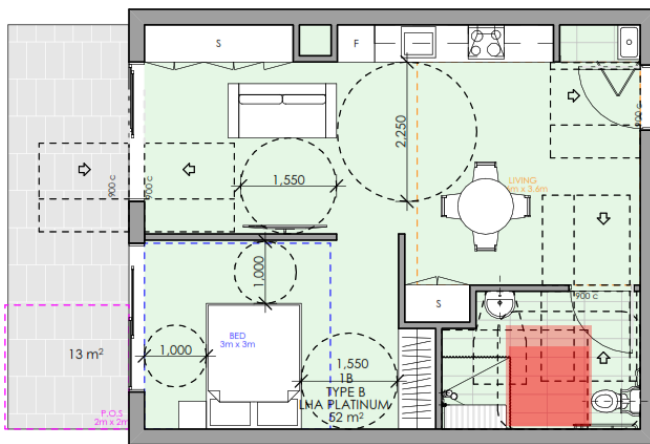

Type B

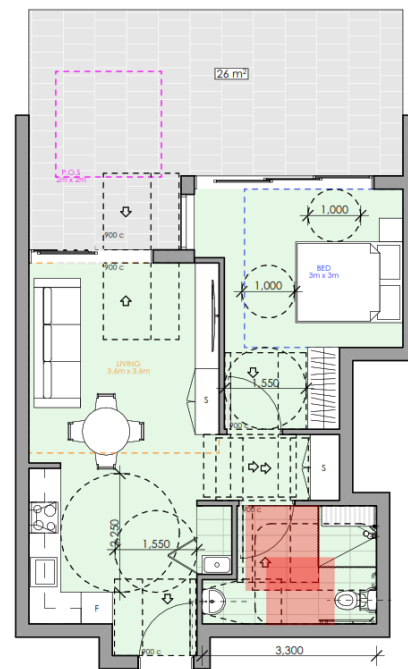

Type E

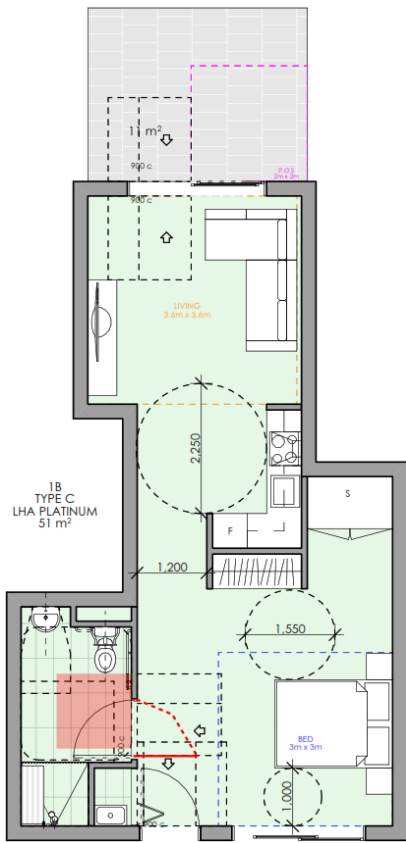

Type C, door swing within the bathroom to swing out at CC stage

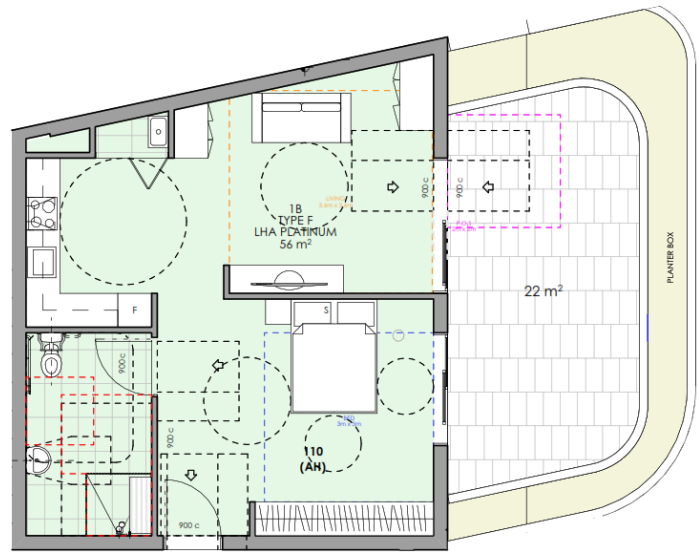

Type F

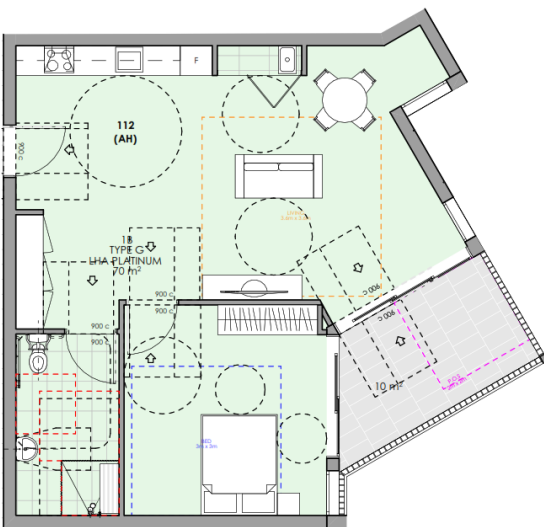

Type G

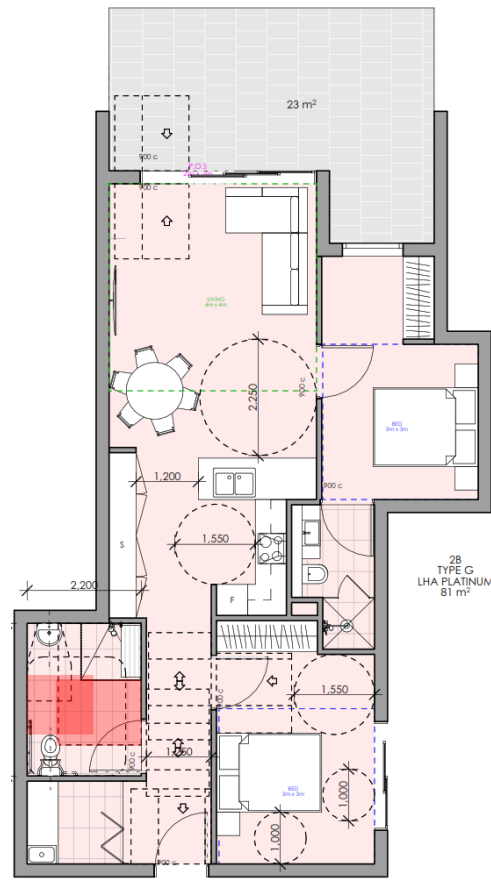

Type G

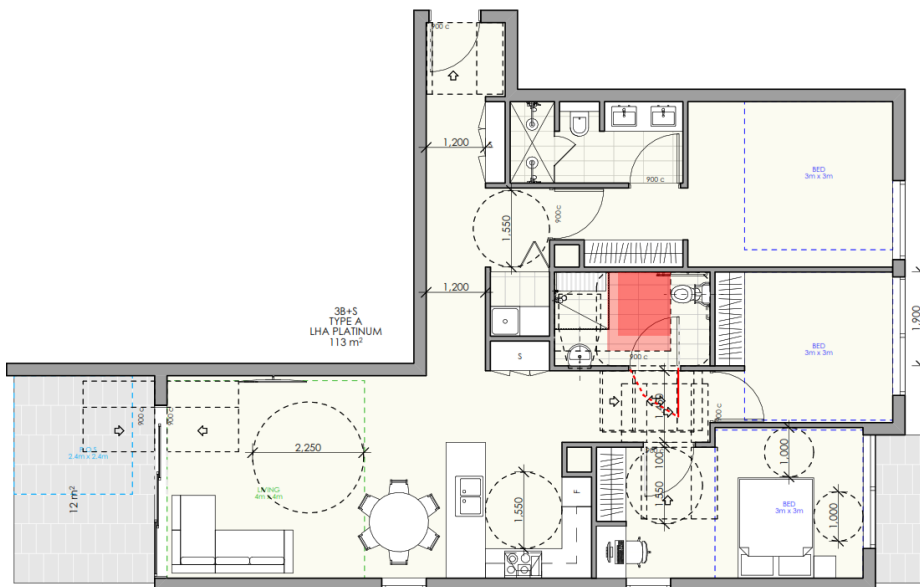

Type A, Door swing within the bathroom to swing out at CC stage.

All details to be verified at the CC stage

Design Element	Requirements (All dimensions noted are required to be clear of finishes as required under AS1428.1)	Compliance /Comments
<p>1 Dwelling Access</p>	<p>a. Provide a safe and continuous 1.2M clear width pathway from front site boundary to an entry door to the dwelling.</p> <p>b. Path including any ramps and walkways to have no steps, even firm, slip-resistant surface, max 1:40 crossfall, max slope of 1:14 with landings of 1.2M every 9M and landings every 15M for 1:20 walkways. 1.2M clear width of ramps are required.</p> <p>c. Pathway may be provided via an associated car parking in which case the car parking space to be</p> <ul style="list-style-type: none"> ▪ 3800 (width) x6000 (length), ▪ even, firm and slip resistant, level surface of 1:40 max grade and ▪ 1:33 max grade for bitumen ▪ a vertical clearance over the parking space of at least 2500mm; and ▪ a covered parking space to ensure protection from the weather. <p>d. Step ramp may be provided at an entrance doorway. The step ramp to be max 190mm height, max 1:10 grade, max 1900mm length. 1.2M clear width of ramps are required.</p> <p>e. Level landings of 1200mm are required exclusive of the swing of the door or gate and to be provided at the head and foot of the ramp.</p>	<p>Capable of compliance. Details to be verified at CC stage of works</p> <p>Complies. Details to be verified at CC stage of works</p> <p>N/A</p> <p>Complies with spatial requirements. Details to be verified at CC stage of works</p>
<p>2</p>	<p>a. Dwelling Entry should provide an entrance door with</p> <p>i. min clear opening width of door to be 900mm</p>	<p>Complies. Details to be verified at CC stage of works</p>

Dwelling entry

- ii. Step free threshold of max 5mm with rounded or beveled lip
- iii. reasonable shelter from the weather
- b. Level landing of 1500x1500mm at step-free entrance door on the arrival / external side of the entrance door. Complies with spatial requirements. Details to be verified at CC stage of works
- c. Max permissible threshold is less than 56mm where provided with a 1:8 grade threshold ramp. N/A
- d. Entrance to be connected to a pathway (specified under Element 1) Complies. Details to be verified at CC stage of works
Note: The entrance to incorporate waterproofing and termite management requirements as specified in the NCC

3

Internal doors and corridors

- a. Doors to rooms on the entry level used for living, dining, bedroom, bathroom, kitchen, laundry and sanitary compartments to be
 - i. 900mm clear opening and
 - ii. provided with a level threshold of max 5mm between abutting surfaces with rounded or beveled lipComplies. Details to be verified at CC stage of works
- b. Internal corridors and passageways to doorway to be min 1.2M clear (measured from skirting to skirting) Complies with spatial requirements. Details to be verified at CC stage of works

4

Toilet

- a. One Toilet to be provided on the ground or entry level that provides,
 - i. Min 1200mm between walls or amenities.
 - ii. Min 1200mm clear space in forward of the WC pan exclusive of door swing.
 - iii. The toilet pan to be positioned in the corner of a room to enable handrails
 - iv. a toilet seat positioned between 450mm – 460mm from the nearest wall as measured from the centre line of the toilet;
 - v. 600mm minimum clearance forward of the cistern measured from the front of the cistern to the front of the toilet seat. 800mm (+/-10mm) clearance is required if cistern is recessed; and
 - vi. a height for the seat of between 460mm-480mm above FFLComplies with spatial requirements. Details to be verified at CC stage of works

5

Shower

- a. One bathroom should feature a slip resistant, hobless shower recess. Shower screens are permitted provided they can be easily removed at a later date. Capable of compliance. Details to be verified at CC stage of works
- b. The shower recess should be located in the corner of the room to enable the installation of grabrails at a future date.
- c. The hobless shower recess described in (a) should:
 - i. be located in a bathroom on the ground (or entry) level;
 - ii. with dimensions of at least 1160mm (width) x 1100mm (length).

- iii. dimensions of at least 1600mm (width) x 1400mm (length) forward of the shower recess

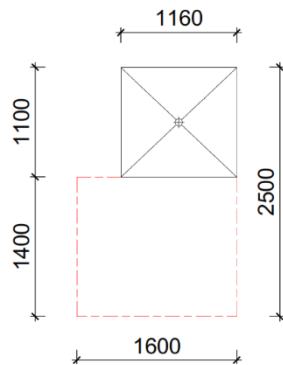

For hobless specification please see Australian Standard AS3740-3.6. Reinforcement guidelines for walls in bathrooms and toilets are found in element 6

6 Reinforcement of bathroom & toilet walls

- a. Except for walls constructed of solid masonry or concrete, the walls around the shower, bath (if provided) and toilet should be reinforced to provide a fixing surface for the safe installation of grabrails.
- (b), (c) and (d) the walls around toilet, bath and shower to be via:
 - i. Noggins with a thickness of at least 25mm
 - ii. Sheeting with a thickness of at least 12mm

Complies. Details to be verified at CC stage of works

Complies. Details to be verified at CC stage of works

Refer to diagrams provided in the Livable Housing Guideline document.

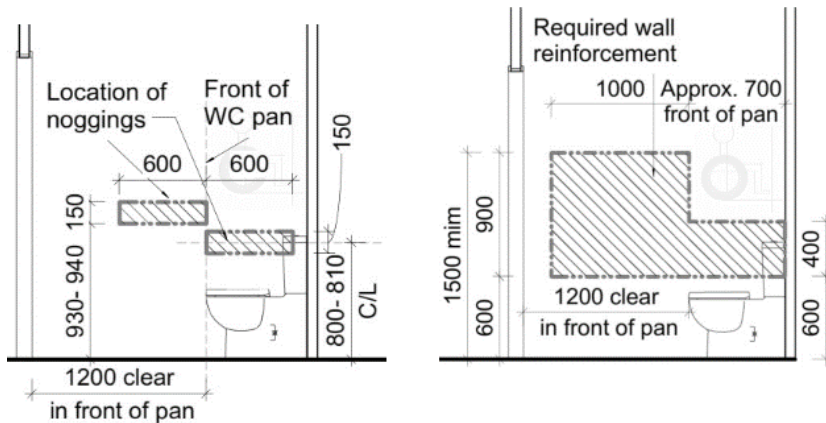

[Image description: Diagram shows wall reinforcements options of noggings or sheeting for a toilet]

Note: In a standalone toilet, the wall reinforcements are required to both sides. Any door openings/ door frames are required to be clear of the required wall reinforcements. If wall with cavity slider is used for wall reinforcements, then allow

for additional thickness for the wall.

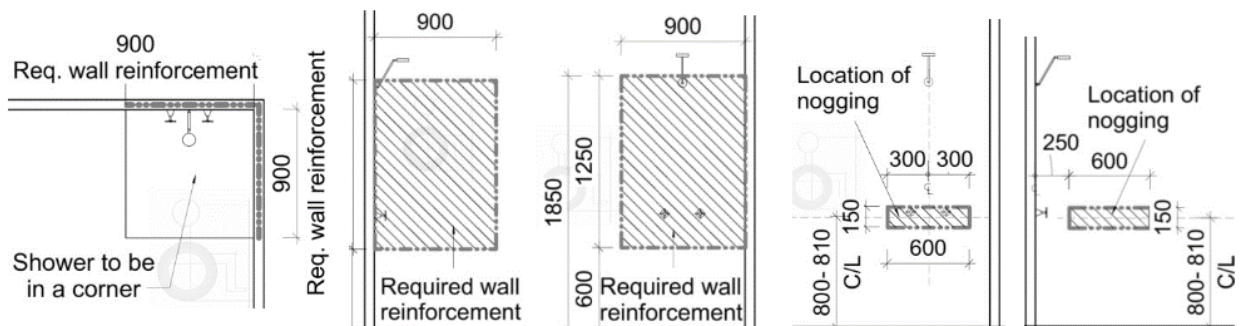

[Image description: Diagram shows wall reinforcements options of noggings or sheeting for a shower]

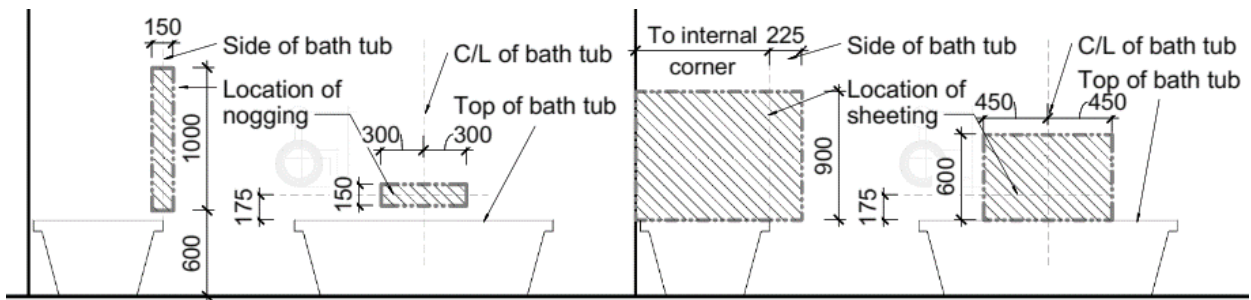

[Image description: Diagram shows wall reinforcements options of noggings or sheeting for a bathtub]

7

Internal Stairways

Stairways in dwellings must feature:

- i. a continuous handrail on one side of the stairway where
- ii. there is a rise of more than 1m. a minimum clear width of 1000mm
- iii. a minimum clear width of 1000mm;
- iv. be straight in design
- v. be positioned adjoining a load bearing wall.
- vi. closed risers;
- vii. continuous handrails on both sides of the stairway
- viii. minimum landing areas of 1200mm x 1200mm at the top and base of the stairway.

Note: The steps must provide a slip resistance finish and suitable non-slip tread as specified in the NCC. Handrails on both sides of the stairway are preferred.

N/A

No internal stairway in units.

8

Kitchen space

- a. The kitchen space should be designed to support ease of movement and adaptation with:
 - i. at least 1550mm clearance provided in front of fixed benches and appliances; and
 - ii. slip resistant flooring.
 - iii. task lighting installed above workspaces.
- b. Floor finishes should extend under kitchen cabinetry to enable cupboards to be removed without affecting the flooring. (Not required for flooring under fixture such as floor oven)

Complies with spatial requirements. Details to be verified at CC stage of works

Complies. Details to be verified at CC stage of works

9

Laundry space

- a. The laundry space should be designed to support ease of movement and adaptation with:
 - i. at least 1550mm clearance provided in front of fixed benches and appliances; and
 - ii. slip resistant flooring.
- b. Floor finishes should extend under Laundry cabinetry to enable cupboards to be removed without affecting the flooring.

Complies with spatial requirements. Details to be verified at CC stage of works

Complies. Details to be verified at CC stage of works

10

Ground floor (or entry level) bedroom

- a. The dwelling should feature a space (or room) on the ground (or entry) level that:
 - i. is of at least 10m² exclusive of robes, skirtings etc
 - ii. provides for a minimum path of travel of at least 1000mm on at least one side of the bed.
 - iii. provides a space of at least 1540mm (width) x 2070mm (in the direction of travel) on the side

Complies with spatial requirements. Details to be verified at CC stage of works

- on the bed that is closest to the door approach;
and
- iv. provides for a minimum path of travel of 1000mm on the remaining sides of the bed.

- b. For Platinum level, it should be assumed that a bed with dimensions 1520mm x 2030mm is present. This will mean that the minimum clear dimensions of a room would need to be 3030mm x 4060mm to meet the Platinum level requirements.

Complies. Details to be verified at CC stage of works

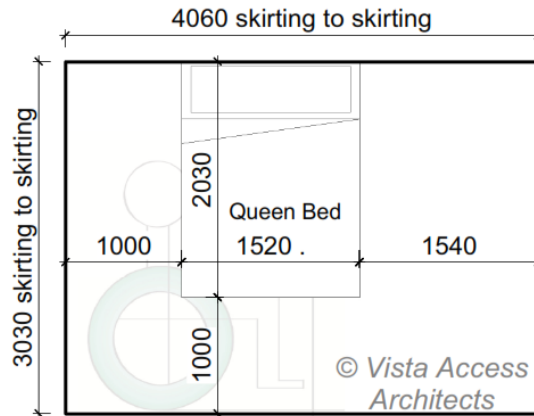

Mirror layout will also comply.

11

Switches and powerpoints

- a. Light switches should be positioned in a consistent location:
 - i. between 900mm – 1100mm above the finished floor level; and
 - ii. horizontally aligned with the door handle at the entrance to a room.
- b. Powerpoints should be installed not lower than 300mm above FFL.
- c. Light and powerpoint switches should be rocker action, toggle or push pad in design with a recommended width of 35mm.

Complies. Details to be verified at CC stage of works

Complies. Details to be verified at CC stage of works

12

Door and tap hardware

- a. Doorways should feature door hardware installed at between 900mm – 1100mm above the finished floor.
- b. Doorways should feature lever or D-pull style door hardware as per AS1428.1
- c. Basins, sinks and tubs should feature lever or capstan style tap hardware with a central spout.

Complies. Details to be verified at CC stage of works

Complies. Details to be verified at CC stage of works

13

Family and Living room space

- a. The family/living room should accommodate a free space, minimum 2250mm in diameter, to enable ease of movement clear of furniture.

Complies with spatial requirements. Details to be verified at CC stage of works

14

Window sills

- a. Window sills on the ground (or entry) level in living areas and bedroom spaces should be positioned no higher than 1000mm above the finished floor level to enable enjoyment of the outlook.

Capable of compliance. Details to be verified at CC stage of works

Note: A concession from (a) is reasonable in kitchen, bathroom and utility spaces.

- b. Window controls should be able to be easy to operate with one hand and located within easy reach from either a seated or standing position.

Complies. Details to be verified at CC stage of works

16

Flooring

All floor coverings should:

- i. be firm and even, slip resistant and
- ii. feature a level transition between abutting surfaces (a maximum vertical tolerance of 5mm between abutting surfaces is allowable provided the lip is rounded or beveled).

Complies. Details to be verified at CC stage of works

Statement of Experience

Vista Access Architects specialises in disability access consultancy services including, Disability Access and inclusion requirements, Access Performance Solutions under the NCC, NDIS SDA Certifications, Livable Housing Certifications and Changing Places Certifications.



Farah Madon - Director

- ACA Accredited Access Consultant
- NDIS Accredited SDA Assessor
- Livable Housing Assessor
- Changing Places Assessor

- Accredited and Fellow member of the Access Consultants Association (ACA) - 281
- NDIS Accredited SDA (Specialist Disability Accommodation) Assessor SDA00001
- Architect registered with the NSW Architect's Registration Board - Registration 6940
- Member of Australian Institute of Architects (RAIA), A+ Practice Member 49397
- Registered Assessor of Livable Housing Australia - Registration 10032
- Global Alliance on Accessible Technologies and Environments (GAATES) - BE-02-021-20
- Registered Assessor of Changing Places Australia - Registration CP006

Farah's Educational Profile and Qualifications include:

- Bachelor of Architecture Degree with Honours (B.Arch.)
- International Certification of Accessibility Consultants – Built Environment (ICAC-BE) Program, Level 2 Advanced Accessibility Consultant
- Diploma of Access Consulting

Farah has 20 years of experience of working in the field of Architecture and Access.

Farah is the lead author of the NDIS SDA Design Standard. She has been invited on multiple occasions as an expert witness for Access related matters in the NSW Land and Environment Court.

Farah currently participates on the following key committees concerning access for people with disabilities, on an honorary basis:

- President of Access Consultants Association (previously known as ACAA)
- Member of Standards Australia's ME-064 Committee responsible for the AS4299 and AS1428 suite of standards.
- Community Representative Member of the Penrith City Council's Access Committee
- Member of Australian Institute of Architect's National Enabling Architecture Committee (NEAC)
- Member of Changing Places Australia Technical Advisory Team

Some Recent Awards presented to Farah include:

- 2023 Mulgoa Local Woman of the Year
- 2022 ACAA Fellow Award
- 2021 Australian Access Awards - Winner for the Educational App of the Year - SDA Tools
- 2021 Excellence in Inclusion - Altitude Awards
- 2019 Penrith Citizen of the Year
- 2019 ACAA Access Inclusion Award





Vanessa Griffin

- ACA Accredited Access Consultant
- NDIS Accredited SDA Assessor
- Livable Housing Assessor
- Changing Places Assessor

- Accredited member of ACA (previously ACAA) - 500
- NDIS Accredited SDA Assessor SDA00009
- Registered LHA Assessor - 20035
- Registered Assessor of Changing Places Australia - CP010



Jenny Desai

- ACA Accredited Access Consultant
- NDIS Accredited SDA Assessor
- Livable Housing Assessor

- Accredited member of ACA (previously ACAA) - 572
- NDIS Accredited SDA Assessor SDA00043
- Registered LHA Assessor - 20242
- Master's degree in Design M.Des



Art Phonsawat

- ACA Accredited Access Consultant
- NDIS Accredited SDA Assessor
- Livable Housing Assessor

- Accredited member of ACA (previously ACAA) - 695
- NDIS Accredited SDA Assessor
- Registered LHA Assessor



Trin Woo

- ACA Affiliate Access Consultant

- Affiliate Member of ACA (previously ACAA) - 776
- Bachelor's degree in Architecture B.Arch



Swapna Menon

- ACA Affiliate Access Consultant

- Affiliate Member of the ACA (previously ACAA) - 798
- Bachelor's degree in Architecture B.Arch



Rushi Pansare

- ACA Affiliate Access Consultant

- Affiliate Member of ACA (previously ACAA) - 898
- Bachelor's degree in Architecture B.Arch

