

Proposed Residential Development

**2 Fishburn Crescent,
Castle Hill**

TRAFFIC AND PARKING ASSESSMENT REPORT

5 September 2025

Ref 23513

VARGA TRAFFIC PLANNING Pty Ltd
Transport, Traffic and Parking Consultants 

Table of Contents

1.0	INTRODUCTION	1
1.1	Project Summary	1
1.2	Purpose of this Report	4
2.0	SEAR'S	5
2.1	SEARS.....	5
2.2	Relevant Policies and Guidelines	5
3.0	EXISTING TRAFFIC CONDITIONS	7
3.1	Site Location.....	7
3.2	Road Hierarchy.....	7
3.3	Existing Traffic Controls	13
3.4	Existing Sustainable and Public Transport Options	15
3.5	Existing Kerbside Parking Restrictions.....	18
3.6	Existing Traffic Conditions	20
4.0	PROPOSED DEVELOPMENT	21
4.1	Overview of Proposed Development.....	21
4.2	Projected Traffic Generation Potential.....	27
4.3	Traffic Implications – Road Network Capacity	28
4.4	Intersection Operations.....	29
4.5	Car Parking Assessment	31
4.6	Loading/Servicing Provisions	33
4.7	Swept Turning Path Analysis	33
5.0	CONCLUSIONS & RECOMMENDATIONS	35
APPENDIX A	TRAFFIC SURVEY DATA	
APPENDIX B	SIDRA MOVEMENT SUMMARIES	
APPENDIX C	SWEPT TURNING PATH DIAGRAMS	

Tables

Table 1: Secretary's Environmental Assessment Requirements

Table 2: Network Performance

List of Illustrations

Figure 1	Location
Figure 2	Site
Figure 3	Road Hierarchy
Figure 4	Existing Traffic Controls
Figure 5	Existing Public Transport
Figure 6	Proposed Haulage Route

1.0 INTRODUCTION

1.1 Project Summary

This report has been prepared on behalf of *Arada* to accompany an Environmental Impact Statement (EIS) to the *NSW Department of Planning* for a residential development proposal to be located at 2 Fishburn Crescent, Castle Hill (Lot 1 in DP 1316896) (Figures 1 and 2).

The proposed development involves demolition of existing structures on the site to facilitate the construction of a residential flat building with a basement parking area.

The development proposal is defined as a State Significant Development (SSD) in accordance with *State Environmental Planning Policy (Planning Systems) 2021*, therefore this traffic report has been prepared to accompany an EIS to the *NSW Department of Planning*.

In 2018, the NSW Government released a document called *‘Greater Sydney Region Plan: A Metropolis of Three Cities’*. As the population grows, the goal is to rebalance economic and social opportunities across Greater Sydney by dividing Sydney into three core cities to allow residents to live within 30 minutes of their jobs, education and health facilities, services and other great places.

The document envisages Castle Hill as becoming a “Strategic Centre” with a focus on “*Transit Orientated Development*” such as the *Showground Station Precinct* in which the subject site is located. The *Showground Station Precinct* is envisaged to become an attractive and well-connected neighbourhood that achieves housing targets supported by necessary infrastructure.

The location of the site has excellent connectivity to public transport services including the Sydney Metro service, and is ideally located to encourage a greater use of alternate, and sustainable modes of transport.

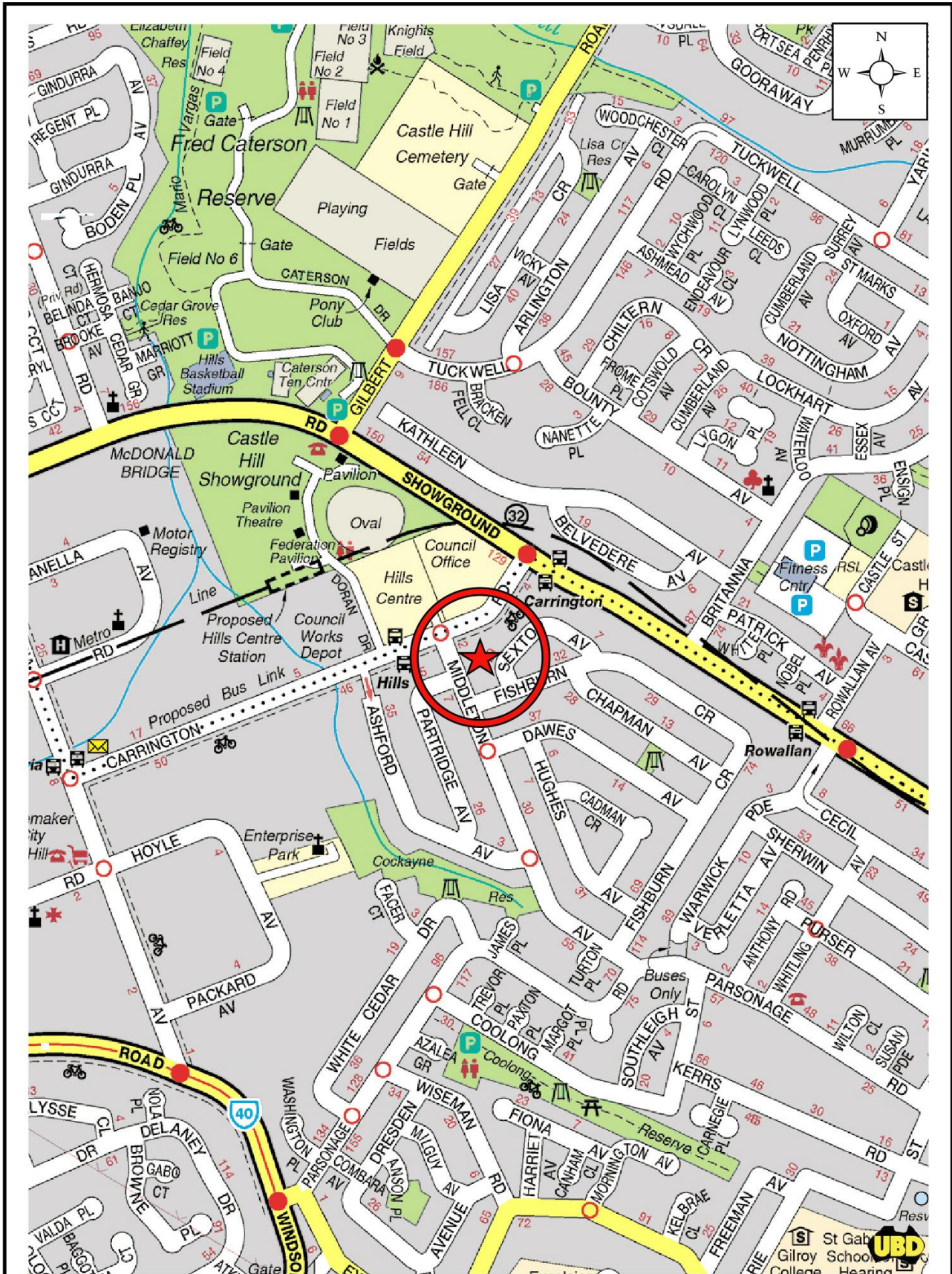

VARGA TRAFFIC PLANNING Pty Ltd
Transport, Traffic and Parking Consultants

LOCATION
FIGURE 1

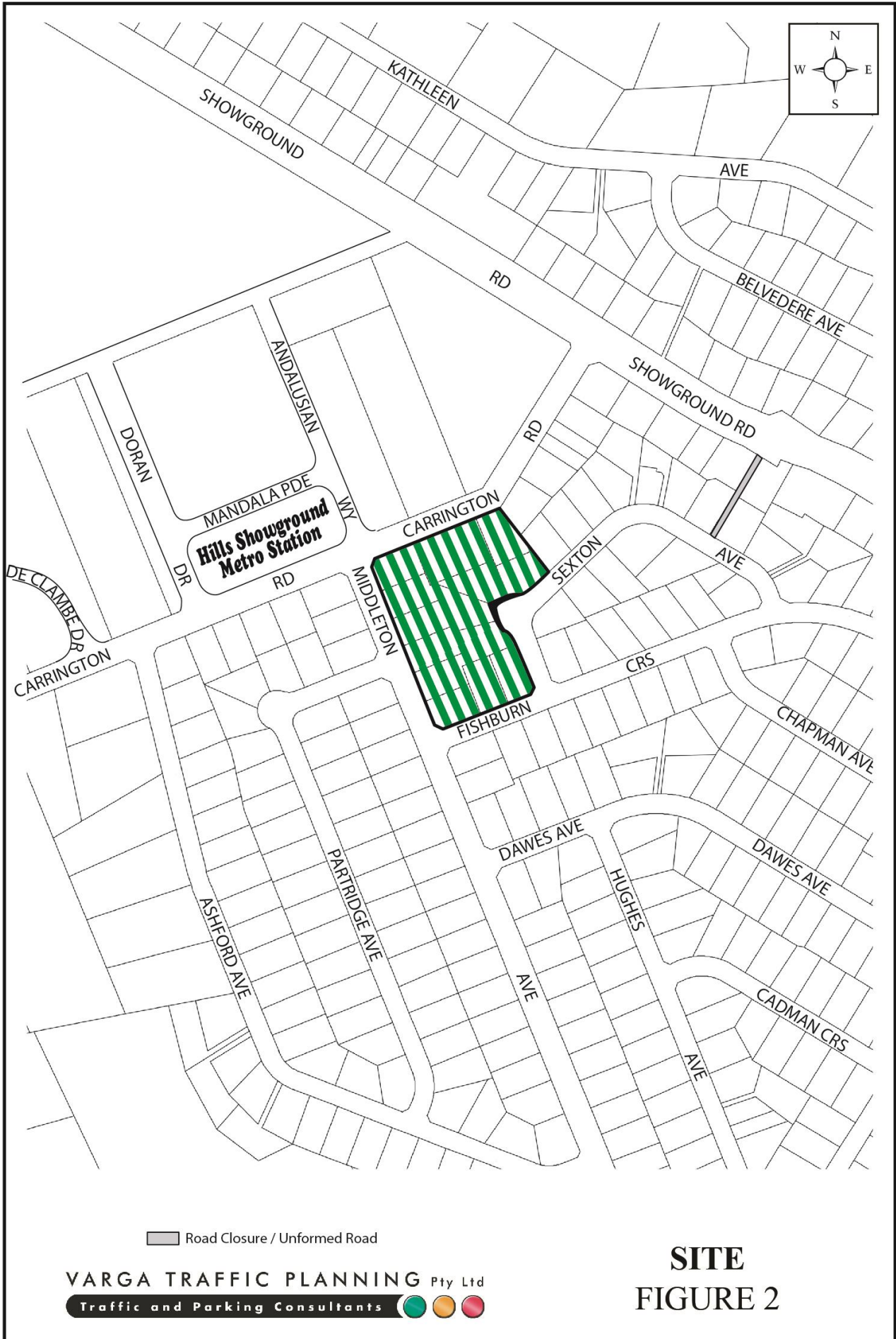

Off-street parking is to be accommodated in a multi-level basement parking area in accordance with Council's *Showground Station precinct DCP* requirements.

Vehicular access to the site is proposed to be provided via a new combined entry/exit driveway located in the middle of Fishburn Crescent site frontage.

Loading/servicing for the proposed development is expected to be undertaken by a variety of commercial vehicles up to and including 12.5m long heavy rigid vehicles (HRV trucks). A 12.5m HRV loading bay is proposed on ground level, adjacent to the waste store room.

1.2 Purpose of this Report

The purpose of this report is to assess the traffic and parking implications of the expansion proposal and to that end this report:

- describes the site and provides details of the development proposal
- reviews the road network in the vicinity of the site and the traffic conditions on that road network
- reviews the sustainable forms of transport available in the vicinity of the site
- estimates the traffic generation potential of the development proposal and assigns that traffic generation to the road network serving the site
- assesses the traffic implications of the development proposal on the surrounding local and arterial road network in terms of road network capacity
- reviews the geometric design features of the proposed car parking and loading facilities for compliance with the relevant codes and standards
- assesses the adequacy and suitability of the quantum of off-street parking and loading provided on the site.

2.0 SECRETARY'S ENVIRONMENTAL ASSESSMENT REQUIREMENTS

2.1 SEARS

On 30 April 2025, The NSW Department of Planning, Housing and Infrastructure issued the *Secretary's Environmental Assessment Requirements (SEARs)* for the State Significant Development (SSD), SSD-83112728, which included the following:

“Provide a Transport Impact Assessment (TIA) in accordance with the processes and methodology recommended in the Guide to Transport Impact Assessment (GTIA) published by TfNSW.

If the construction of the development would cause interruptions to regular pedestrian and transport routes (including public transport, active transport or general traffic), a preliminary Construction Traffic (or Transport) Management Plan (CTMP) should be prepared as part of the TIA to mitigate any such impacts.”

This report addresses the SEARs requirement for a Traffic Impact Assessment (TIA).

A Construction Traffic Management Plan (CTMP) and a Green Travel Plan (GTP) have been prepared under separate cover.

2.2 Relevant Policies and Guidelines:

- The Hills Local Environmental Plan 2019
- The Hills Development Control Plan 2012 (August 2024)
- Roads Act 1993 (NSW)
- State Environmental Planning Policy (Transport and Infrastructure) 2021
- State Environmental Planning Policy (Housing) 2021
- Guide to Transport Impact Assessment (Transport for NSW, Version 1.1 2024)
- Standards Australia AS2890.1 – 2004 (Part 1: Off-street Car Parking)

- Standards Australia AS2890.2 – 2018 (Part 2: Off-street commercial vehicle facilities)
- Standards Australia AS2890.3 – 2015 (Part 3: Bicycle Parking)
- Standards Australia AS2890.6 – 2022 (Part 6: Off-street parking for people with disabilities)
- Traffic Control at Work Sites 2020 (Transport for NSW)

3.0 EXISTING CONDITIONS

3.1 Site Location

Site

The subject site is located in land zoned *R4 – High Density Residential* in the southeast corner of the Carrington Road and Middleton Avenue intersection, approximately 200m southeast of the *Hills Showground Metro Station*.

The site has street frontages approximately 110 metres in length to Carrington Road, approximately 140 metres in length to Middleton Avenue, approximately 80 metres in length to Fishburn Crescent, approximately 110 metres in length to Sexton Avenue, and occupies an area of approximately 14,000m².

The subject site is currently a vacant lot of land. The site was previously occupied by 15 residential dwellings, each dwelling with its own off-street parking provision and vehicular access driveway.

A recent aerial photography of the site and its surroundings is provided below:



Source: MetroMap

Greater Sydney Region Plan – A Metropolis of Three Cities

In 2018, the NSW Government released a document called ‘*Greater Sydney Region Plan: A Metropolis of Three Cities*’. As the population grows, the goal is to rebalance economic and social opportunities across Greater Sydney by dividing Sydney into three core cities to allow residents to live within 30 minutes of their jobs, education and health facilities, services and other great places.

The document envisages Castle Hill as becoming a “Strategic Centre” with a focus on “*Transit Orientated Development*” such as the *Showground Station Precinct* in which the subject site is located.



Showground Station Precinct DCP

The subject site is located in the *Showground Station Precinct* as detailed in *Part D, Section 9 of The Hills Development Control Plan (DCP) 2012*.

Council's *LEP & DCP* envisage the redevelopment of the precinct as a *Transit Oriented Development* to increase the number of people who walk, cycle or use public transport as the main form of transport.

The subject site is zoned *R4 - High Density Residential* under *Part 9 - Showground Station Precinct of LEP 2019*, with a maximum height of 27m and an FSR of 1.9:1.

The *Showground Station Precinct* is envisaged to become an attractive and well-connected neighbourhood that achieves housing targets supported by necessary infrastructure. It is anticipated that the precinct will provide up to 9000 additional dwellings and 2300 additional jobs by 2036.

Extracts from the *Showground Station Precinct DCP* illustrating the land to which this section of the *DCP* applies, the Precinct Structure Plan, Indicative Street Network and Hierarchy, Existing and Proposed Cycleway Network and Local Street – Land Dedication Plan are reproduced in the following pages.

Fishburn Crescent and Sexton Avenue are defined as “local street” in the *DCP*, and the proposed development makes provision for land dedications to widen both Fishburn Crescent and Sexton Street to achieve the local street section as illustrated on Figure 13 of the *DCP* which is also reproduced below.

A number of road improvements and upgrades have been undertaken in the *Showground Station Precinct* in recent years to accommodate the projected increase in population and traffic flows.

In particular, intersection upgrades have been undertaken at the Showground Road/Carrington Road, Showground Road/De Clambe Drive, Carrington Road/Middleton Avenue, and Carrington Road/Doran Drive to accommodate the increased traffic flows.

These intersections have been designed to accommodate the upgraded four-lane sub-arterial status of Carrington Road.

In addition, kerbside parking has been prohibited on both sides of Carrington Road as part of its upgrade to a four-lane sub-arterial road. Signalised pedestrian crossings have been provided in the local area to accommodate the increased pedestrian movements generated by the *Hills Showground Metro Station*.

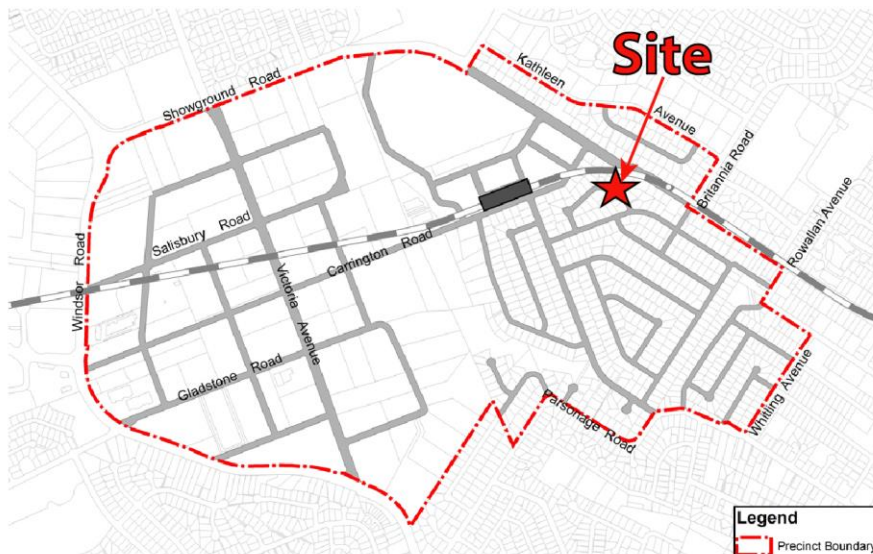

Figure 1 Land to which this Section Applies

Showground Precinct Development Control Plan

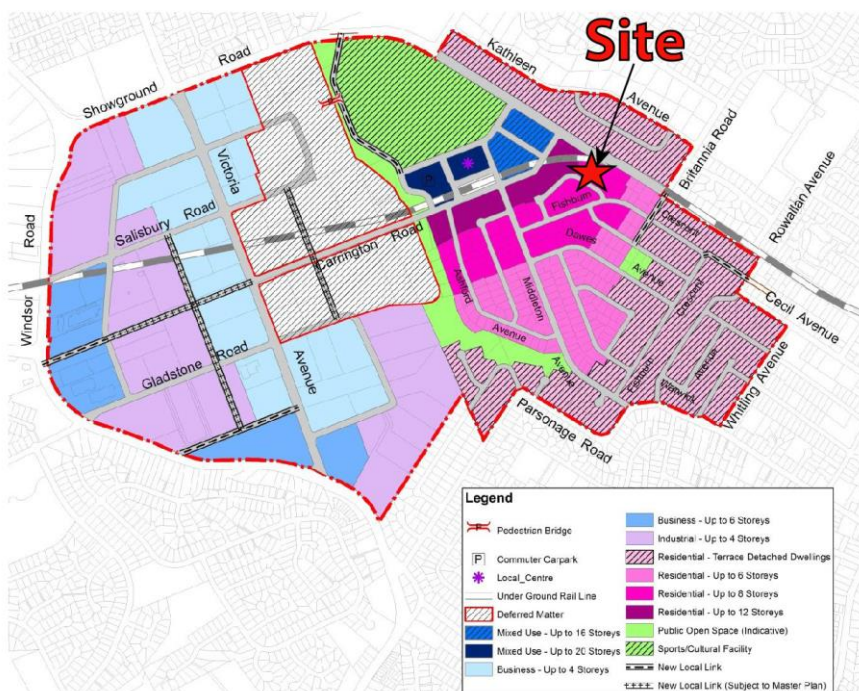

Figure 7 Showground Precinct Structure Plan

Showground Precinct Development Control Plan

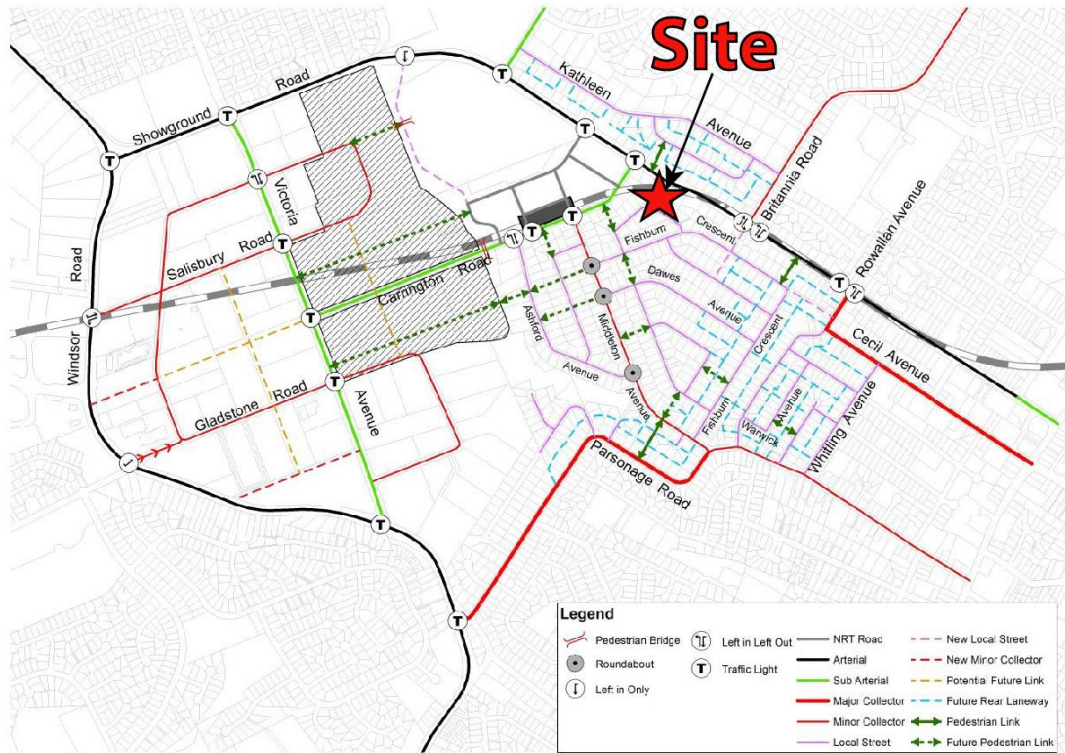

Figure 8 Indicative Street Network and Hierarchy
 (Note: Land within the Deferred Area will be subject to further Master Planning)

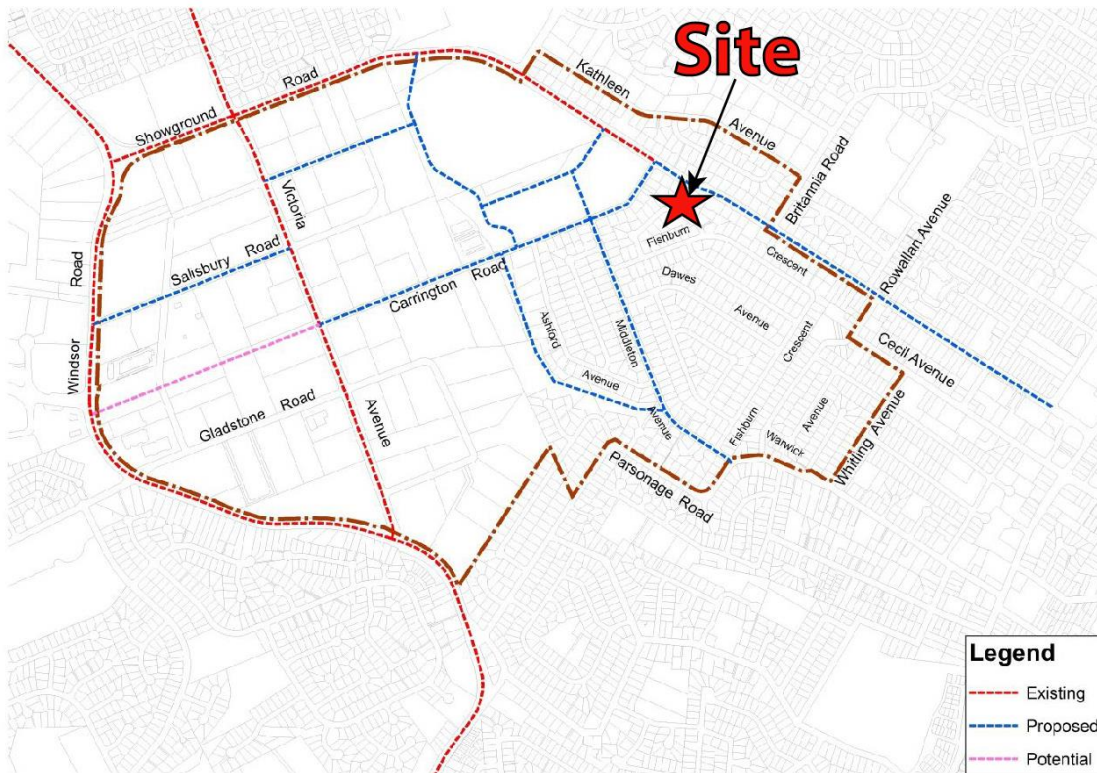

Figure 9 Existing and Proposed Cycleway Network

Showground Precinct Development Control Plan



Figure 10 Local Street - Land Dedication Plan

Showground Precinct Development Control Plan

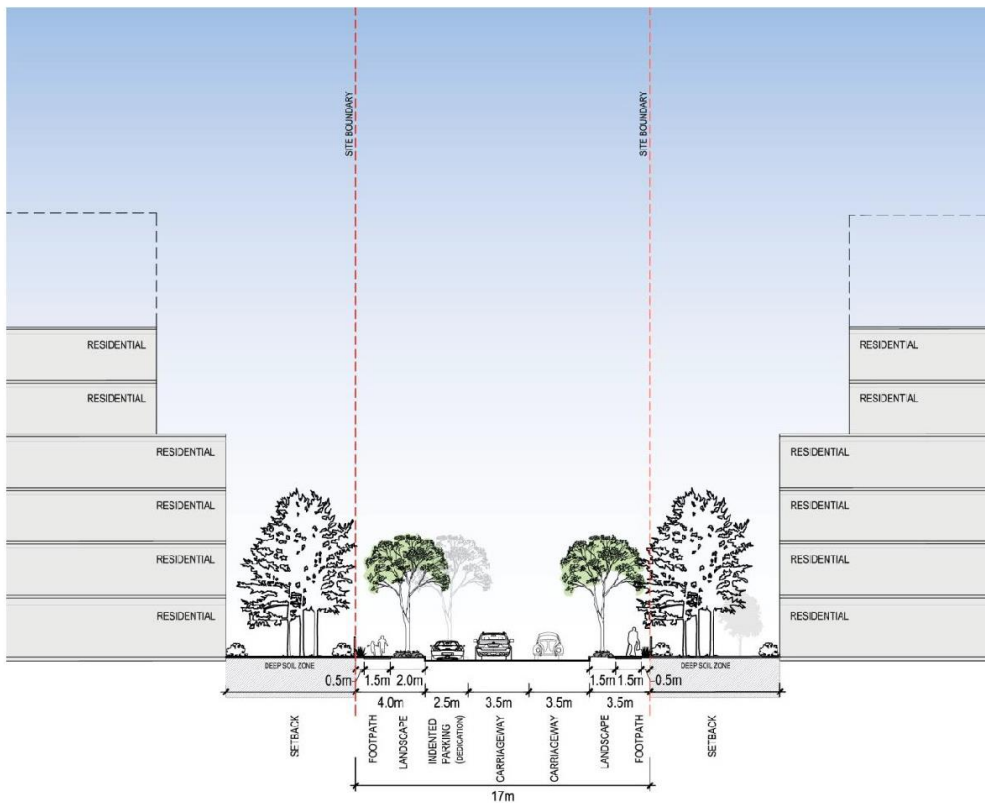

PROFILE 1 LOCAL STREET SECTION & PLAN

Figure 13 - Local Street

3.2 Road Hierarchy

The road hierarchy allocated to the road network in the vicinity of the site by Transport for New South Wales (TfNSW) is illustrated on Figure 3.

Windsor Road is classified by TfNSW as a *State Road* and provides the key north-south road link in the area, linking Windsor suburb in the north to the Westlink M7 motorway in the south. It typically carries two traffic lanes in each direction in the vicinity of the site, with opposing traffic flows separated by a central median island. Parking is not permitted on both sides of the road.

Showground Road is also classified by TfNSW as a *State Road* and provides the key east-west road link in the area. Showground Road has recently been widened and upgraded to provide *additional and extended* left and right-turn lanes at its intersections with Carrington Road and with De Clambe Drive, with bus priority lanes also being provided at the Showground Road/De Clambe Drive intersection.

Victoria Avenue and Gilbert Road are classified by TfNSW as *Regional Roads* and provide further road links in the local area. They typically carry two traffic lanes in each direction in the vicinity of the site, with opposing traffic flows separated by a central median island.

Carrington Road is classified by TfNSW as a *Regional Road* and provides further road link in the local area, linking Showground Road and Victoria Avenue. Carrington Road has recently been upgraded to 4-lane sub-arterial route status, carrying 2 lanes in each direction, with kerbside parking prohibited on both sides of the road.

Middleton Avenue, Fishburn Crescent and Sexton Avenue are local, unclassified roads which are primarily used to provide vehicular and pedestrian access to frontage properties. Kerbside parking is permitted in some sections of these roads, subject to sign-posted restrictions.

Both Fishburn Crescent and Sexton Avenue are to be widened to achieve the local street section as illustrated on Figure 13 of the Council's *Showground Station Precinct DCP*, which is reproduced in the previous page.

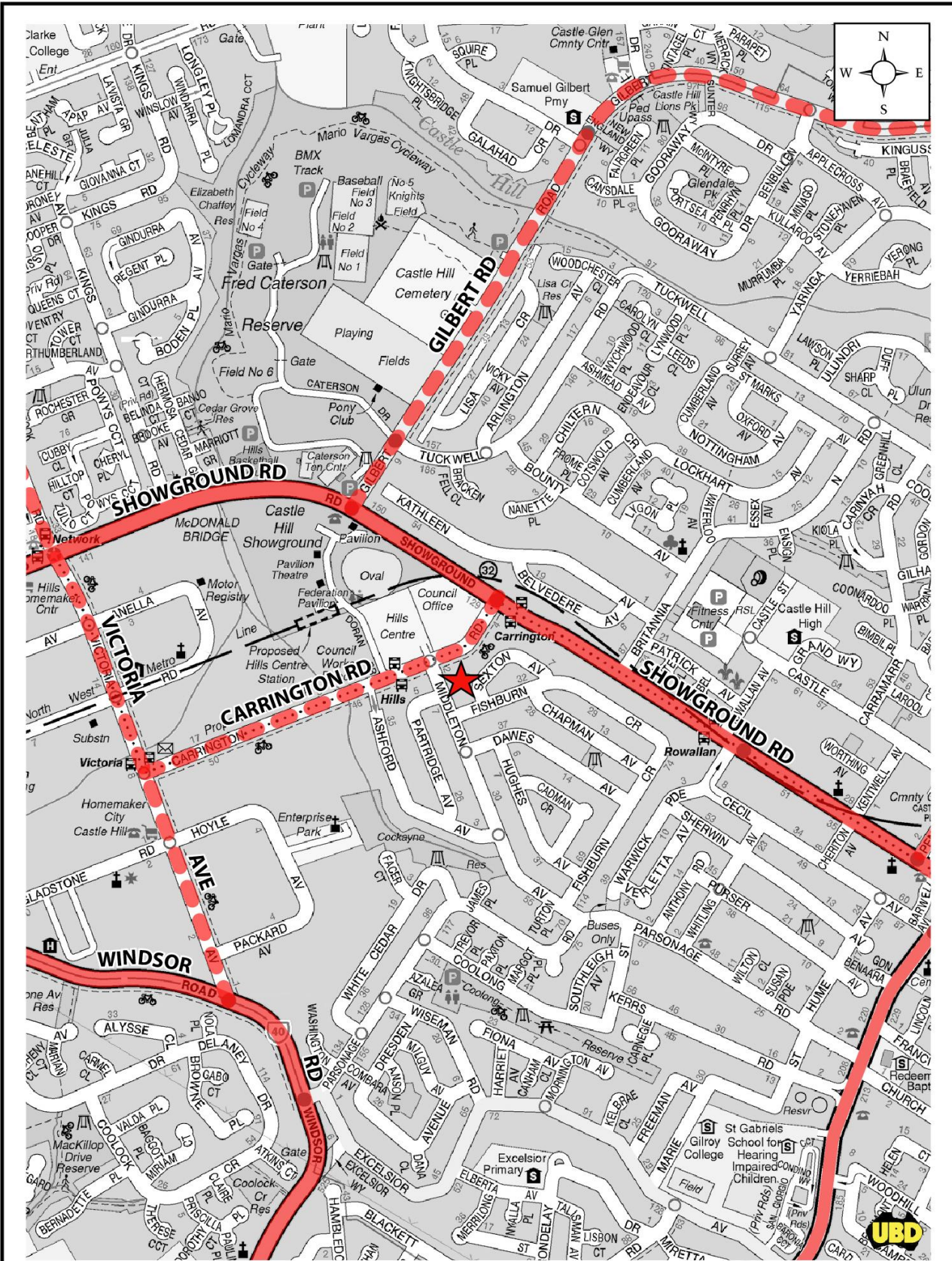

Key: ——— State Road
- - - - - Regional Road

VARGA TRAFFIC PLANNING Pty Ltd
 Transport, Traffic and Parking Consultants

ROAD HIERARCHY
FIGURE 3

3.3 Existing Traffic Controls

The existing traffic controls which apply to the road network in the vicinity of the site are illustrated on Figure 4. Key features of those traffic controls are:

- a 60 km/h SPEED LIMIT which applies to Showground Road
- a 50 km/h SPEED LIMIT which applies to Carrington Road, Middleton Avenue and all other roads in the local area
- TRAFFIC SIGNALS in Carrington Road where it intersects with Andalusian Way, Showground Road, and Doran Drive, and in Showground Road where it intersects with De Clambe Drive
- a ROUNDABOUT in Middleton Avenue where it intersects with Dawes Avenue.

3.4 Existing Sustainable and Public Transport Options

The existing public transport services available in the vicinity of the site are illustrated on Figure 5.

The *Hills Showground Metro Station* is located within approximately 200 metres walking distance from the site servicing the Metro North West & Bankstown Line, operating between Sydenham and Tallawong. Metro services typically operate at 5-minute intervals during commuter peak periods and 10-minute intervals at all other times.

The extension of the Sydney Metro network further to southwest of Sydney is also nearing completion, and will ultimately link Tallawong in the north-west to Bankstown in the south-west via the Sydney CBD. Upon completion commuters will have direct access to Crows Nest and Victoria Cross on the lower north shore, Barangaroo, Martin Place, Gadigal (Pitt Street) and Central in the Sydney CBD, Marrickville, Canterbury, Belmore, Punchbowl and finally Bankstown on the southwest Sydney.

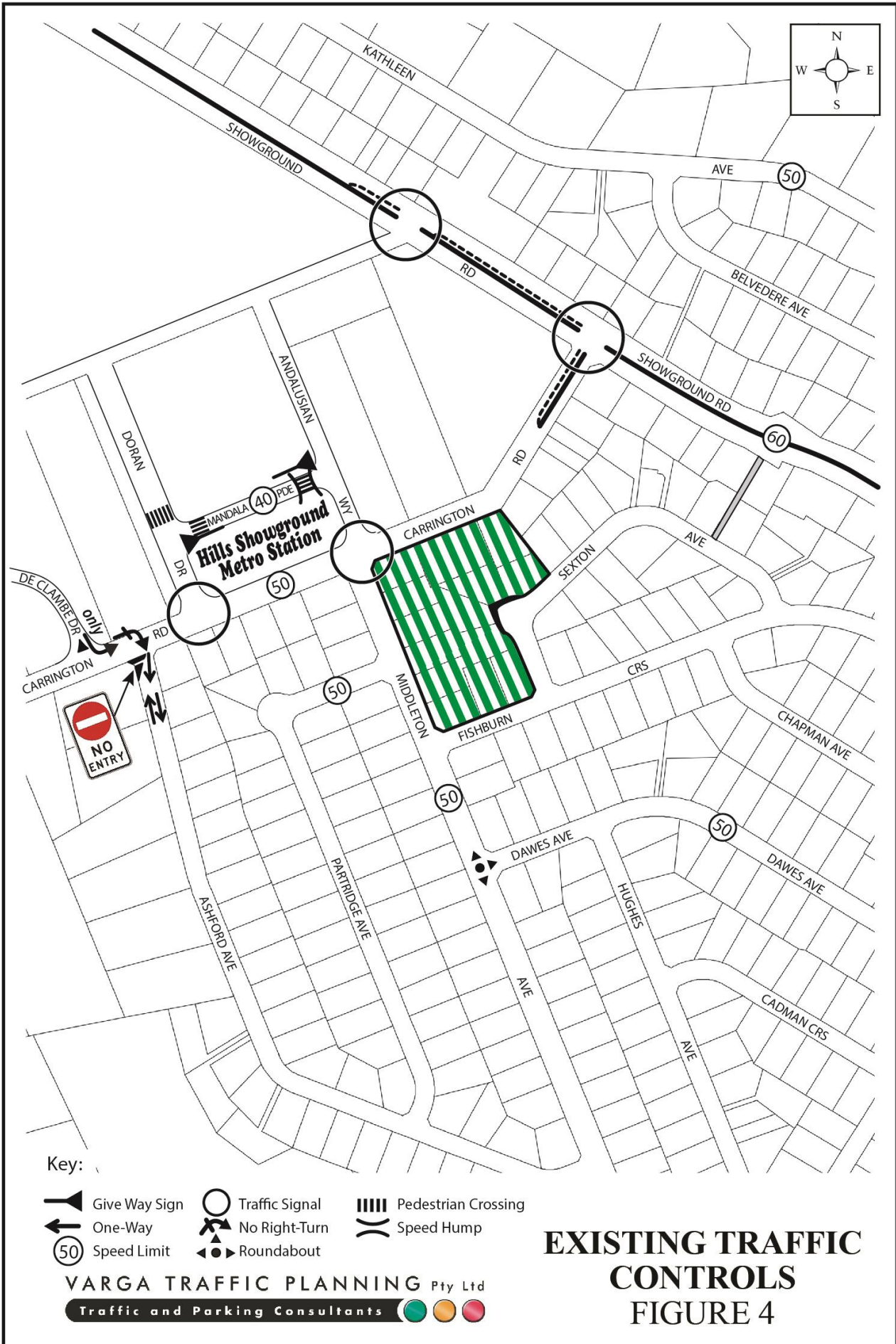

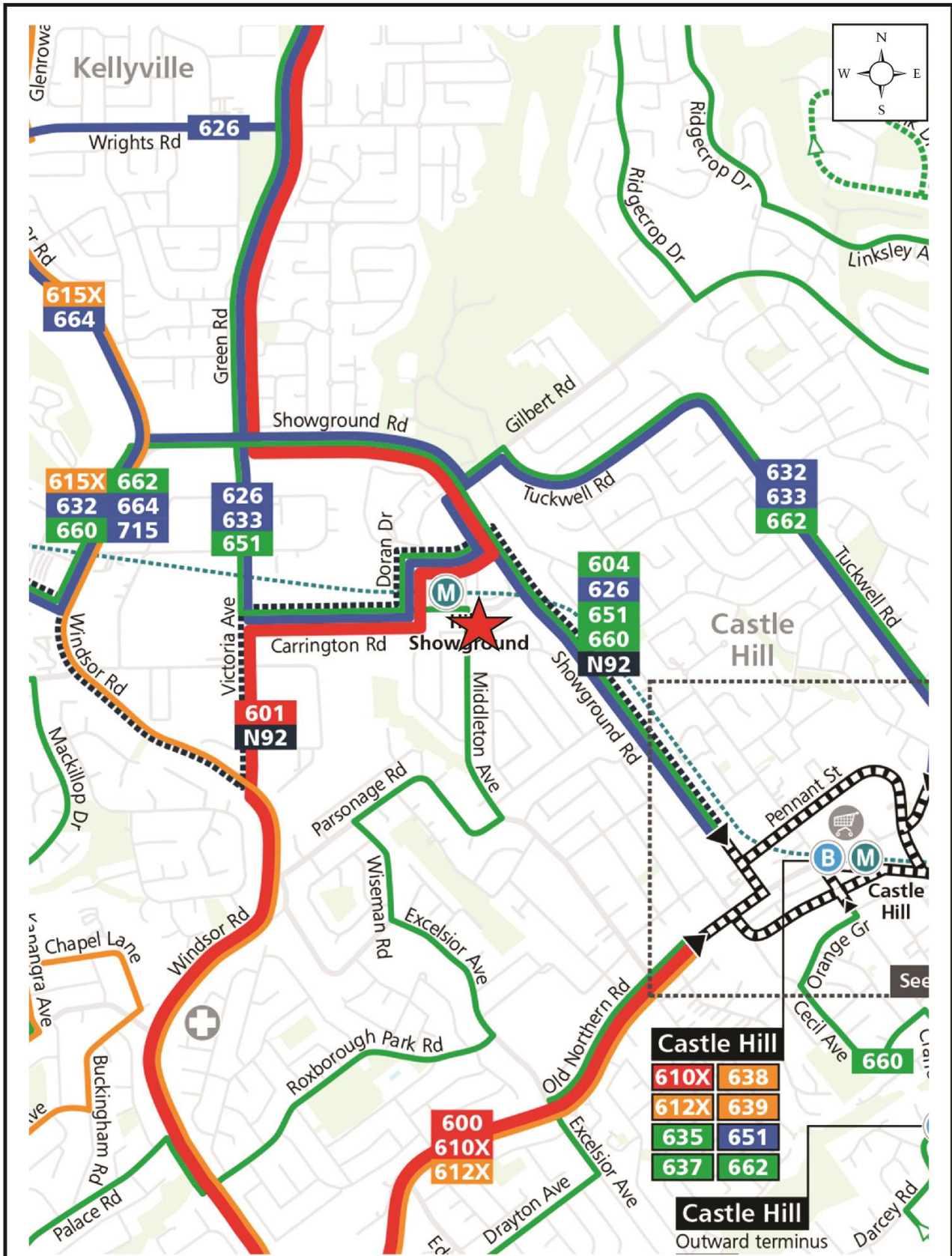

PUBLIC TRANSPORT
FIGURE 5

In addition to railway services, the site is located within a short walking distance to bus stops located in Middleton Avenue, Carrington Road and Showground Road providing access to the following bus routes:

- route 601 – Rouse Hill Station to Parramatta via Hills Showground
- route 604 – Castle Hill to Parramatta via Winston Hills
- route 626 – Kellyville Station to Pennant Hills via Cherrybrook
- route 633 – Rouse Hill Station to Pennant Hills via Kellyville & Castle Hill
- route 651 – Rouse Hill Station to Epping via Castle Hill
- route 660 – Castlewood to Parramatta
- route N92 – Tallawong to City Town Hall (Night Service)

Accordingly, it is clear that the site has excellent connectivity to public transport services including the Sydney Metro service, and is ideally located to encourage a greater use of alternate, and sustainable modes of transport.

3.5 Existing Kerbside Parking Restrictions

The existing kerbside parking restrictions which apply to the road network in the vicinity of the site are illustrated on Figure 6 and comprise:

- NO STOPPING restrictions on both sides of Carrington Road including along the site frontage
- NO PARKING restrictions on northern side of Fishburn Crescent along the site frontage
- 4 HOUR PARKING restrictions on southern side of Sexton Avenue and on both sides of Middleton Avenue, including along the Middleton Avenue site frontage
- UNRESTRICTED PARKING permitted elsewhere in the vicinity of the site, including northern side of Sexton Avenue along the site frontage
- BUS ZONES at regular intervals along both sides of Carrington Road and Middleton Avenue.

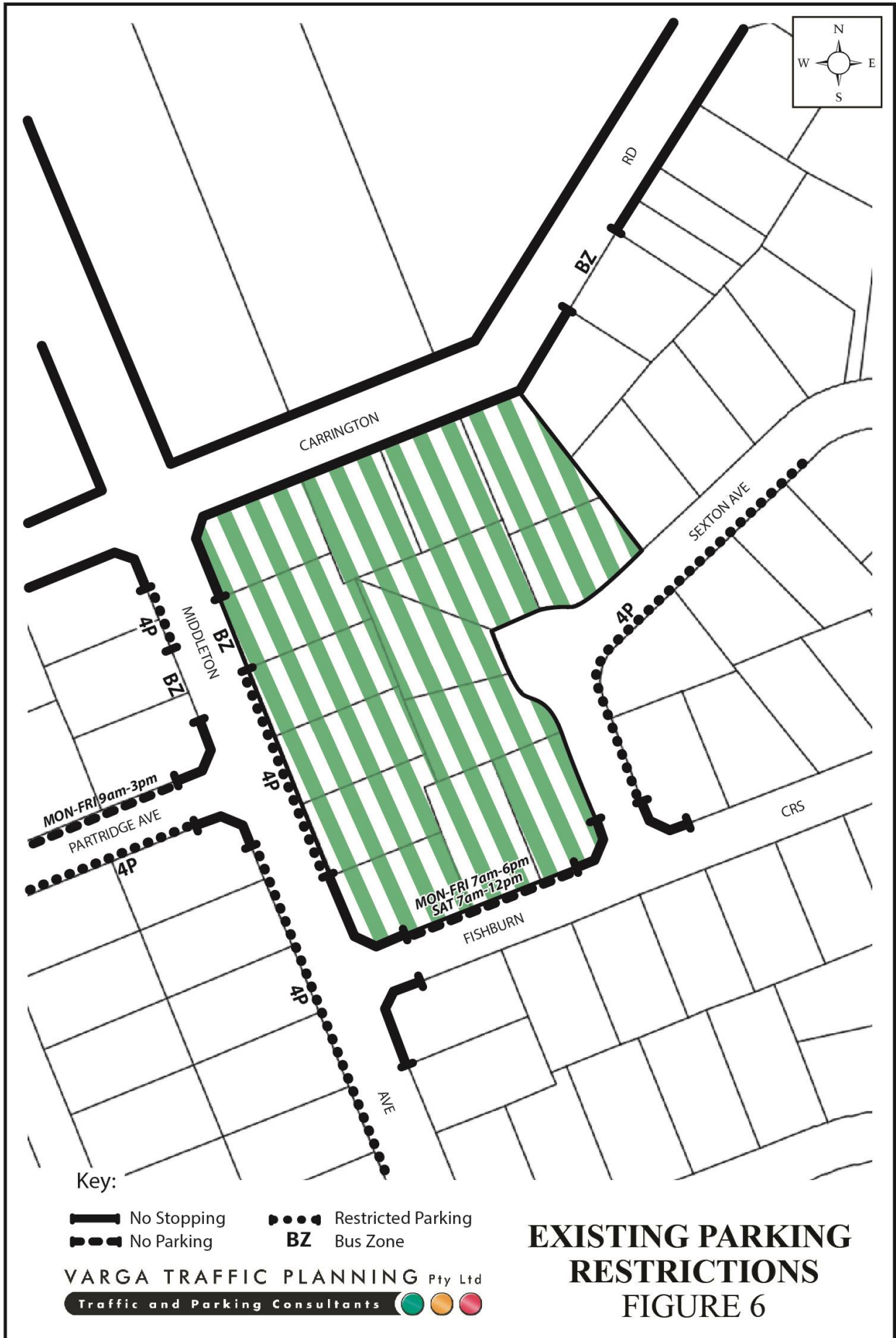

EXISTING PARKING RESTRICTIONS
FIGURE 6

3.6 Existing Traffic Conditions

In order to gain an accurate appreciation of the existing traffic conditions on the road network in the vicinity of the site, peak period traffic surveys were undertaken as part of this traffic study on Wednesday 1st May 2024, at the following intersections:

- Carrington Road & Middleton Avenue & Andalusian Way
- Middleton Avenue & Patridge Avenue
- Middleton Avenue & Fishburn Crescent

It is noted that the morning and afternoon “network” peak periods identified by the traffic surveys at the above intersections occurred at different times. Therefore, the “network” peak periods of the Carrington Road / Middleton Avenue / Andalusian Way intersection, 8:00am – 9:00am for the AM peak period and 5:00pm-6:00pm for the PM peak period, have been adopted for the purposes of this assessment.

The results of the traffic surveys are reproduced in full in Appendix A, revealing that:

- two-way traffic flows in Carrington Road are typically in the order of 1,420-1,540 vehicles per hour (vph) in the AM and PM peak hours
- two-way traffic flows in Middleton Avenue are typically in the order of 600-640 vph in the AM and PM peak hours
- two-way traffic flows in Andalusian Way are typically in the order of 145-220 vph in the AM and PM peak hours
- two-way traffic flows in Patridge Avenue are typically in the order of 25-35 vph in the AM and PM peak hours
- two-way traffic flows in Patridge Avenue are typically in the order of 65-80 vph in the AM and PM peak hours.

4.0 PROPOSED DEVELOPMENT

4.1 Overview of Proposed Development

The proposed development involves demolition of existing structures on the site to facilitate the construction of multiple residential apartment buildings. A total of 431 apartments (including 25 *in-fill affordable*) are proposed by the amended development proposal as follows:

1 bedroom apartments:	41 (including 4 <i>affordable</i> units)
2 bedroom apartments:	251 (including 21 <i>affordable</i> units)
3 bedroom apartments:	122
4 bedroom apartments:	17
TOTAL APARTMENTS:	431

Off-street parking is proposed for a total of 740 cars, 180 bicycles and 32 motorcycles on the site in a lower ground floor parking area and two levels of basement parking area in accordance with *SEPP (Housing) 2021* and Council's *Showground Station Precinct DCP* parking requirements.

Vehicular access to the off-street parking area is proposed to be via a combined entry/exit two-way access driveway located in the middle of Fishburn Crescent site frontage.

Loading/servicing for the proposed development is expected to be undertaken by a variety of commercial vehicles up to and including 12.5m long heavy rigid vehicles (HRV trucks). A 12.5m HRV loading bay is proposed on the ground floor, adjacent to the waste store room. Vehicular access to the dedicated loading facilities is to be provided via the abovementioned two-way vehicular access driveway.

Plans of the proposed development have been prepared by *TURNER* and are reproduced in the following pages.

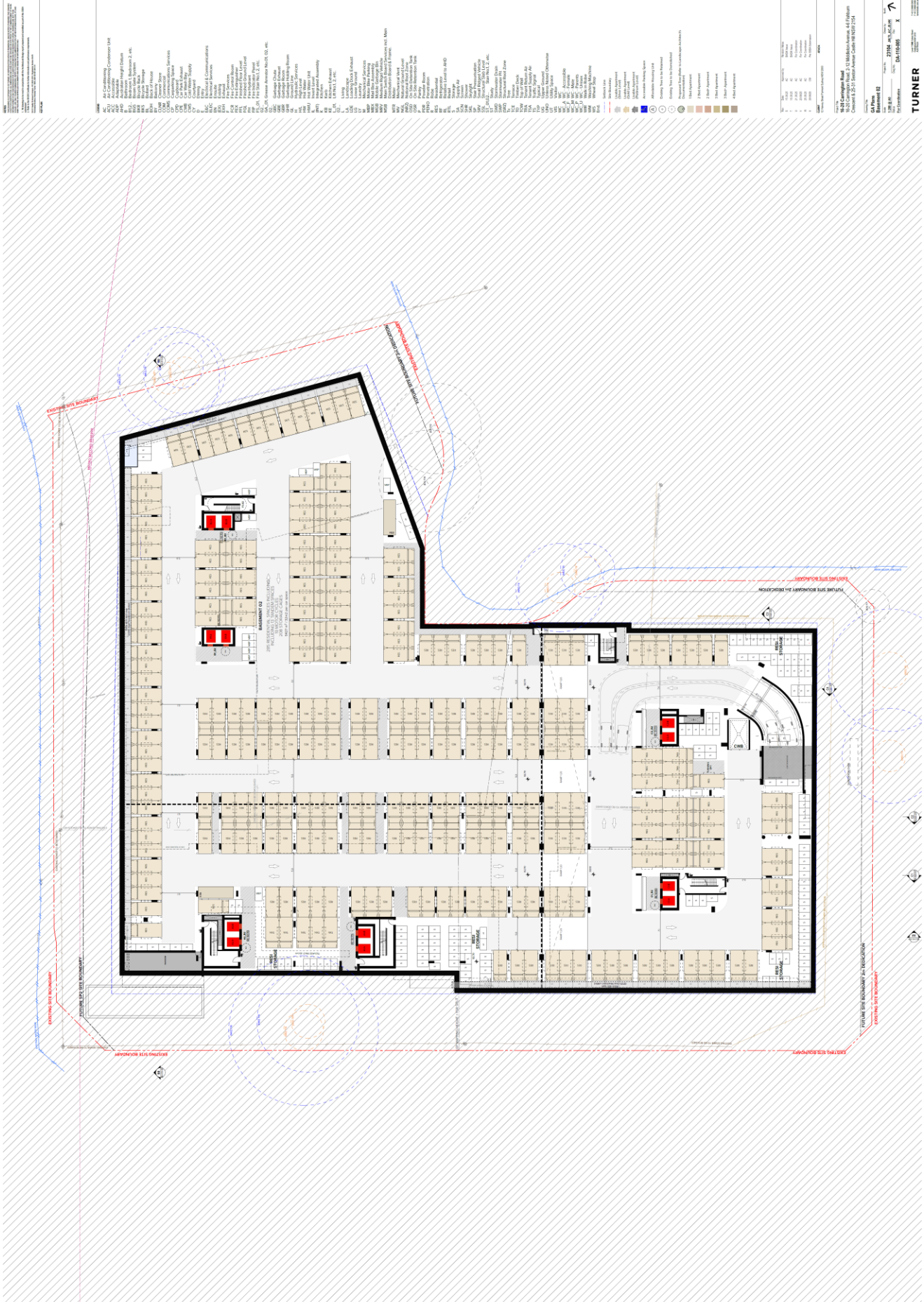

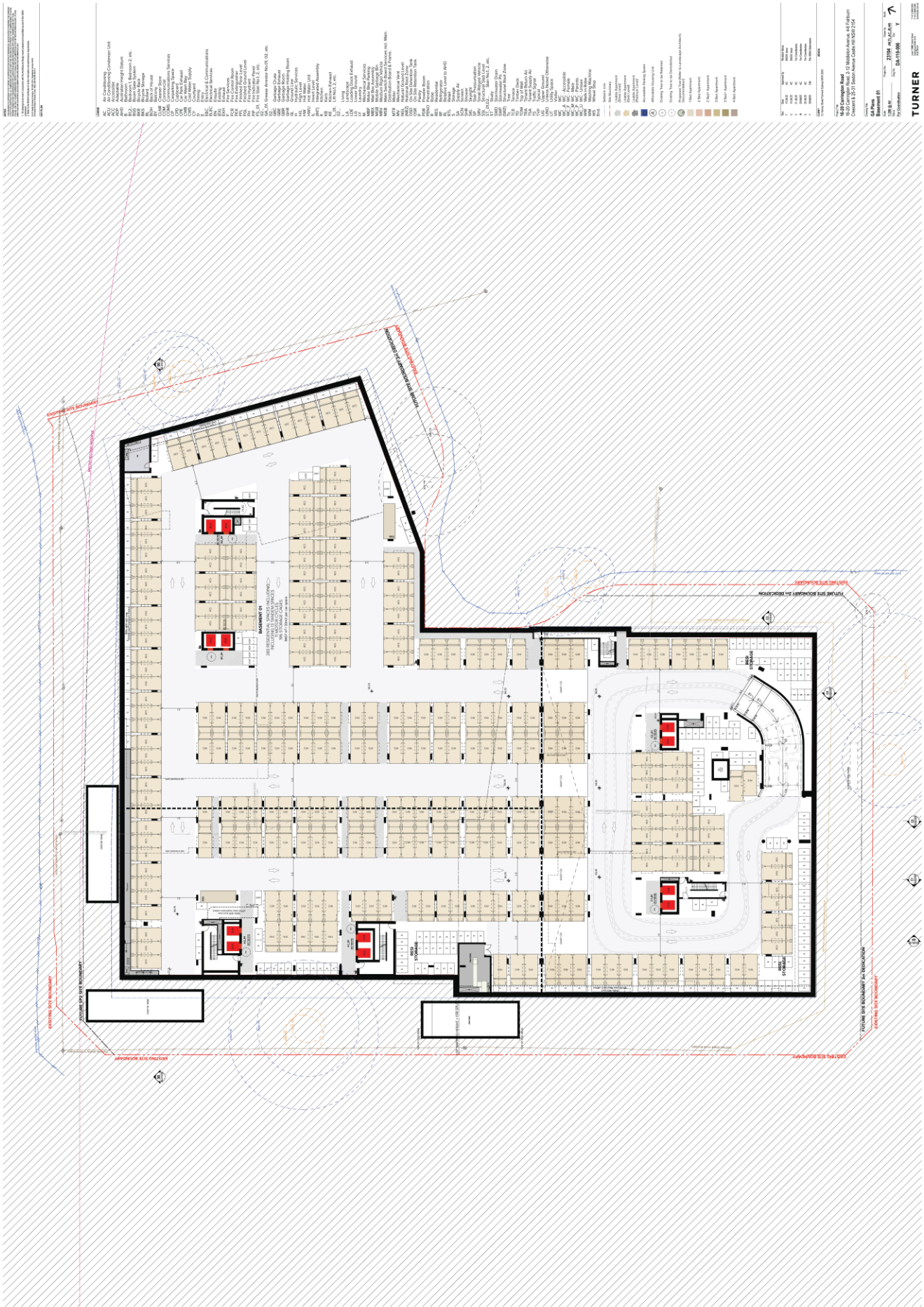

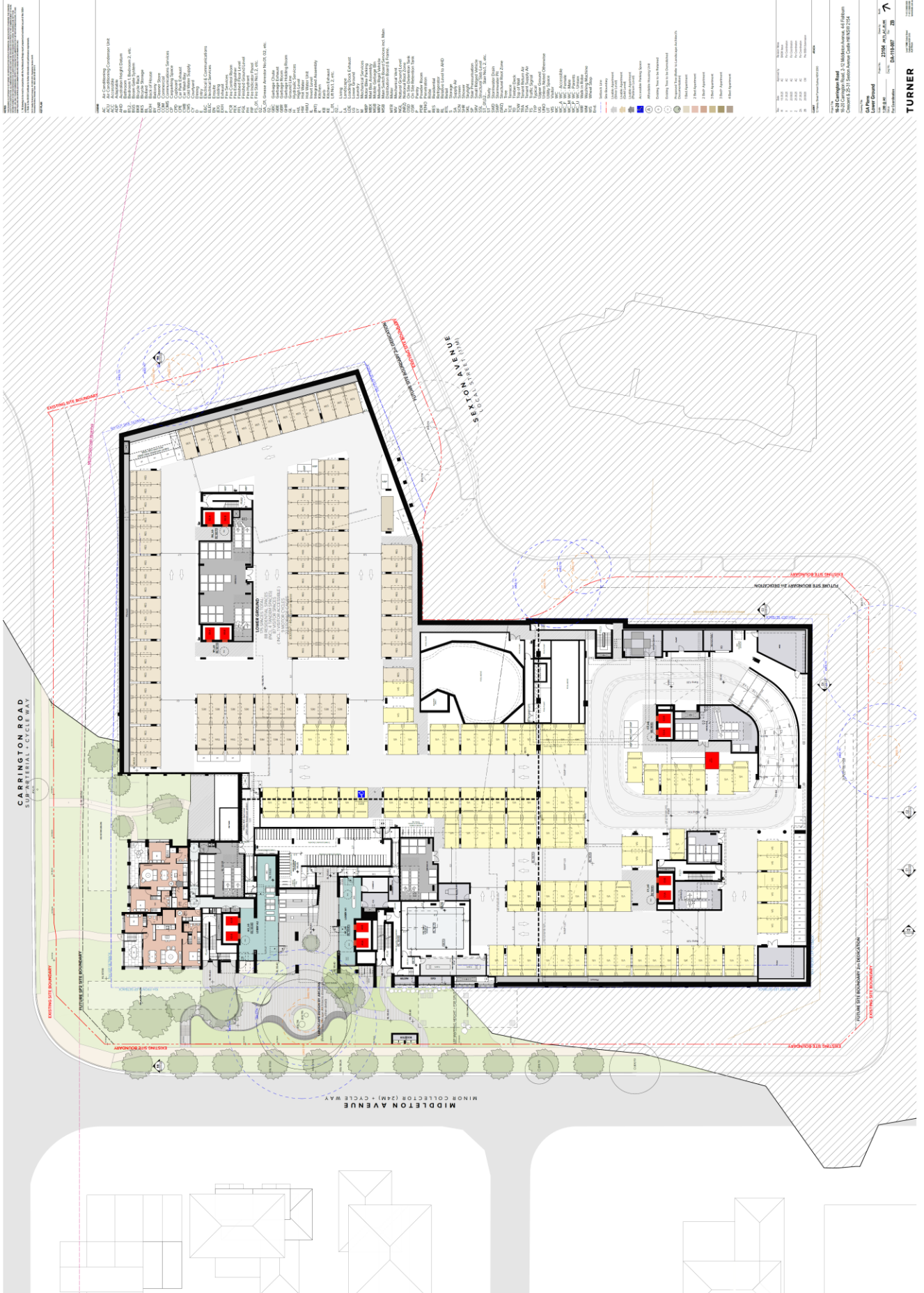

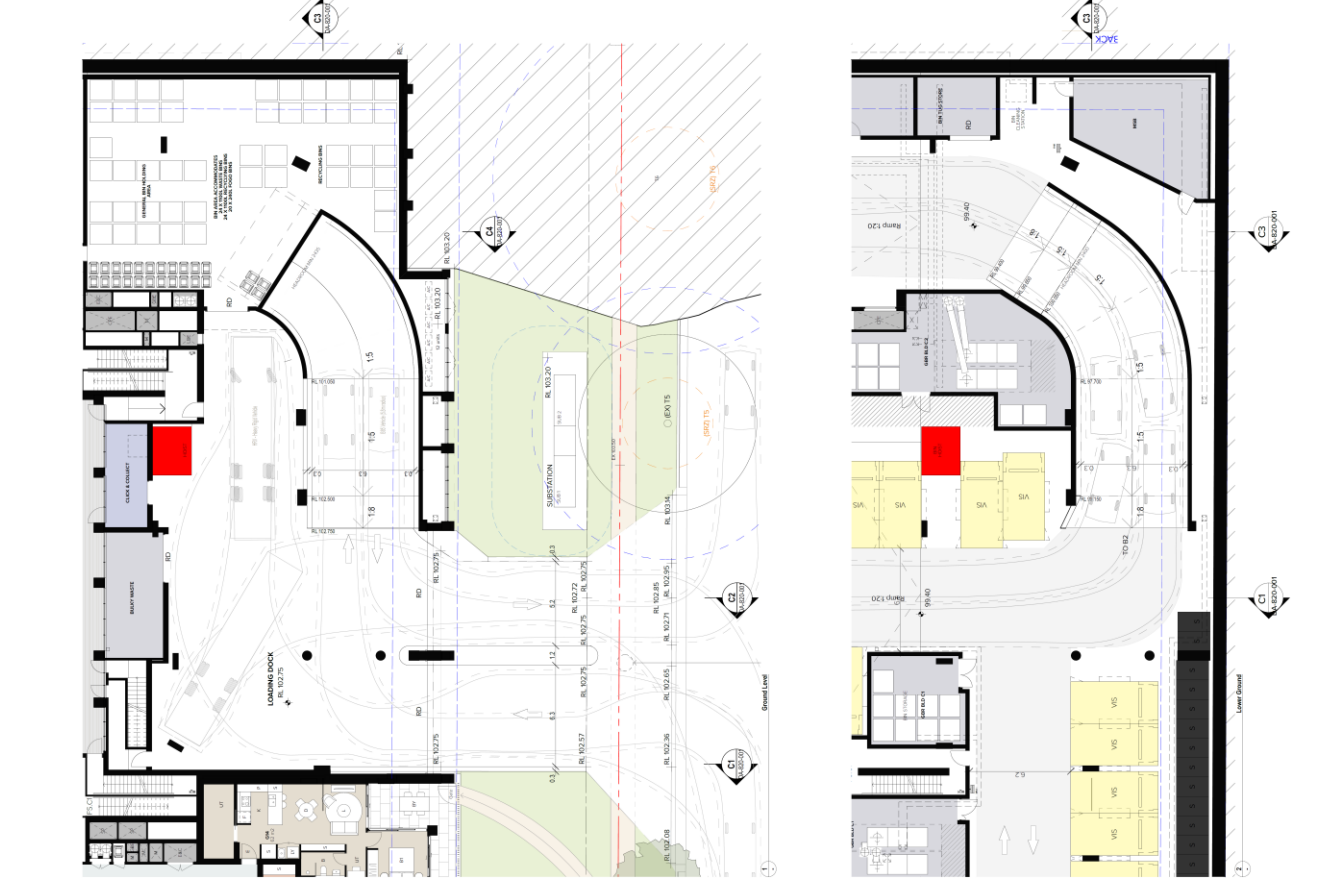
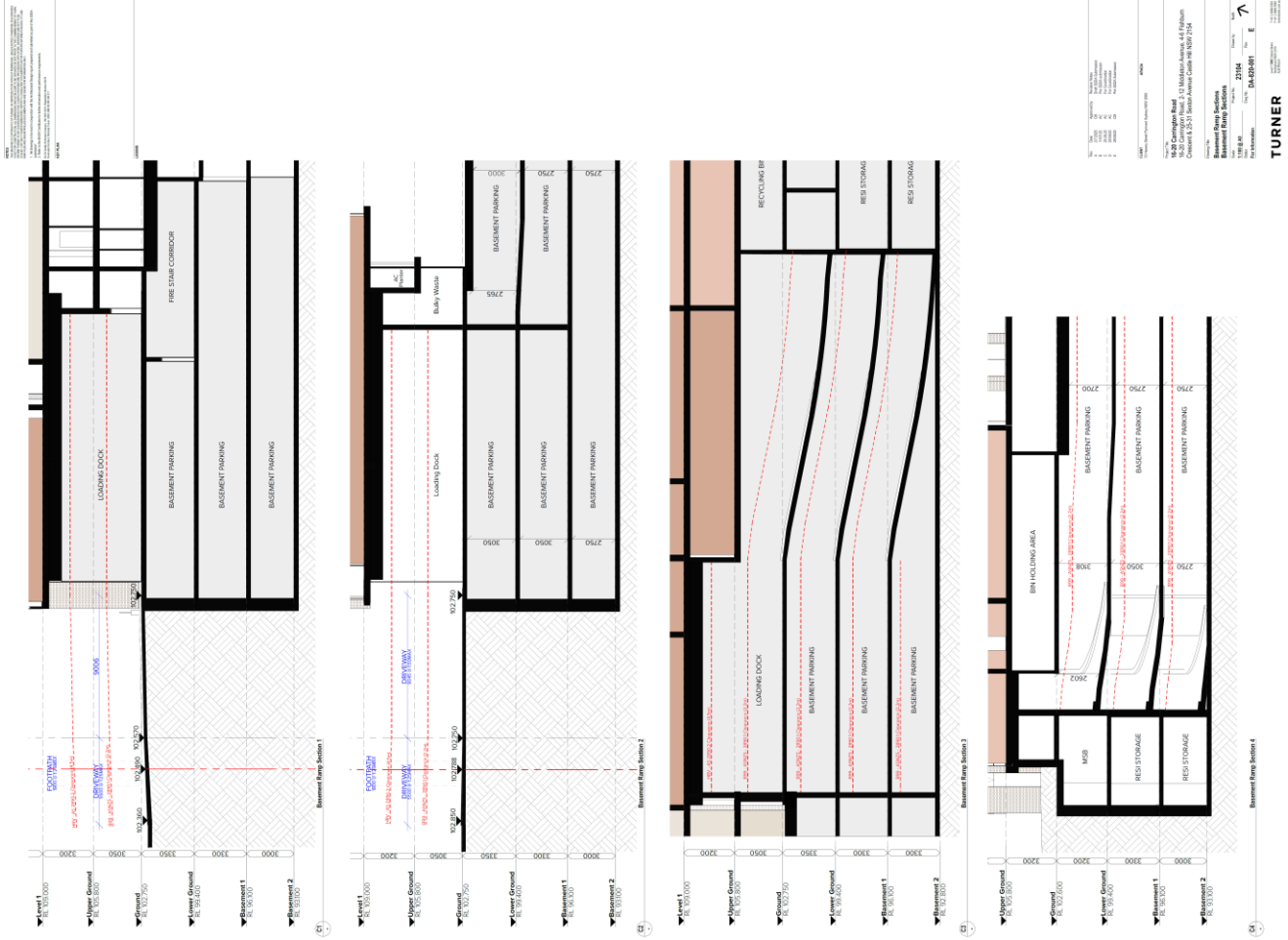

TURNER

100 Sturt Street, Melbourne VIC 3000
 Tel: +61 (0)3 9594 2000
 Fax: +61 (0)3 9594 2001
 Email: info@turner.com.au
 Website: www.turner.com.au

Project: Varga Traffic Planning Pty Ltd
 100 Sturt Street, Melbourne VIC 3000
 Drawing No: 21004
 Date: 04/05/2011

Scale: 1:100
 Drawing No: 21004
 Date: 04/05/2011

Author: [Name]
 Checker: [Name]
 Approver: [Name]

4.2 Projected Traffic Generation Potential

The traffic implications of development proposals primarily concern the effects of the *additional* traffic flows generated as a result of a development and its impact on the operational performance of the adjacent road network, particularly during the morning and afternoon commuter peak periods.

An indication of the traffic generation potential of the development proposal is provided by reference to the Transport for New South Wales's publication *Guide to Transport Impact Assessment, Chapter 5 – Land use Trip Generation (Version 1.1, 2024)*.

The TfNSW *Guide* is based on extensive surveys of a wide range of land uses and nominate the following traffic generation rates which are applicable to the development proposal:

High Density Residential Flat Dwellings (High public transport accessibility in Sydney)

AM Peak:	0.19 vehicle trips per dwelling
PM Peak:	0.15 vehicle trips per dwelling

Application of the above traffic generation rates to the 431 residential apartment units as outlined in the development proposal yields a traffic generation potential of approximately 82 vehicle trips per hour (vph) during the AM commuter peak period and approximately 65 vph during the PM commuter peak period, as set out below:

Projected Future Traffic Generation Potential		
	AM	PM
Residential (431 apartments):	81.9 vph	64.7 vph
TOTAL TRAFFIC GENERATION POTENTIAL:	81.9 vph	64.7 vph

That projected future traffic generation potential should however, be offset or *discounted* by the volume of traffic which could reasonably be expected to be generated by the previous uses of the site, in order to determine the *nett increase (or decrease)* in traffic generation potential expected to occur as a consequence of the development proposal.

The TfNSW *Guide* nominates the following traffic generation rates which are applicable to the previously existing development:

Low Density Residential Dwellings (Sydney)

AM: 0.68 peak hour vehicle trips per dwelling

PM: 0.77 peak hour vehicle trips per dwelling

Application of the above traffic generation rates to the previously existing development on site yields a traffic generation potential of approximately 10 vph during the weekday AM peak period, and approximately 12 vph during the PM peak period, as set out below:

Previously Existing Development Traffic Generation Potential

	AM	PM
Residential (15 dwellings):	10.2 vph	11.6 vph
TOTAL TRAFFIC GENERATION POTENTIAL:	10.2 vph	11.6 vph

Accordingly, it is likely that the development proposal will result in a *nett increase* in the traffic generation potential of the site of approximately 72 vph during the AM commuter peak period, and approximately 53 vph during the PM commuter peak period, as set out below:

**Projected Nett Increase in Peak Hour Traffic Generation Potential
of the Site as a Consequence of the Development Proposal**

	AM	PM
Projected Future Traffic Generation Potential:	81.9 vph	64.7 vph
Less Previously Existing Traffic Generation Potential:	-10.2 vph	-11.6 vph
NETT INCREASE IN TRAFFIC GENERATION POTENTIAL:	71.7 vph	53.1 vph

That projected increase in the traffic generation potential of the site as a consequence of the development proposal is consistent with the *Transit Oriented Development* zoning objectives of the *Showground Station Precinct*, and will not have any unacceptable traffic implications in terms of road network capacity, as demonstrated by the following section of this report.

4.3 Traffic Implications - Road Network Capacity

The traffic implications of development proposals primarily concern the effects that any *additional* traffic flows may have on the operational performance of the nearby road network.

Those effects can be assessed using the SIDRA NETWORK 9 program which is widely used by the TfNSW and many LGA's for this purpose. Criteria for evaluating the results of the analysis are reproduced in the following pages.

The results of the SIDRA capacity analysis of the 3 intersections surrounding the development proposal are summarised in the table below.

4.4 Intersection Operations

Table 2: Network Performance

Intersection	Key Indicators	<u>Existing</u>	<u>Projected</u>	<u>Existing</u>	<u>Projected</u>
		AM Traffic Demand	AM Traffic Demand	PM Traffic Demand	PM Traffic Demand
Carrington Rd & Middleton Ave & Andalusian Way	LoS	B	B	B	B
	DoS	0.539	0.625	0.558	0.611
	Delay	26.7	28.3	28.1	28.2
Middleton Ave & Patridge Ave	LoS	A	A	A	A
	DoS	0.293	0.237	0.294	0.364
	Delay	0.4	0.4	0.3	0.2
Middleton Ave & Fishburn Cres	LoS	A	A	A	A
	DoS	0.203	0.208	0.186	0.202
	Delay	0.9	1.9	0.6	1.5

LoS = Levels of Service

DoS = Degree of Saturation

AVD = Total average vehicle delay (seconds per vehicle)

The detailed SIDRA *movements summaries*, including pedestrian movement capacity analyses for all intersections, are reproduced in full in Appendix B.

In essence, the capacity analysis has found that all intersections will continue to operate at the same *Levels of Service* as the existing scenarios, with *negligible* (less than 2 seconds), if any, increases in average vehicle and pedestrian movement delays as a consequence of the development proposal.

On the above basis, it is clear that the surrounding road network will continue to operate at satisfactory *Levels of Service*, and that the proposed development will not result in any unacceptable traffic implications in terms of road network capacity.

Criteria for Interpreting Results of Sidra Analysis

1. *Level of Service (LOS)*

LOS	Traffic Signals and Roundabouts	Give Way and Stop Signs
'A'	Good operation.	Good operation.
'B'	Good with acceptable delays and spare capacity.	Acceptable delays and spare capacity.
'C'	Satisfactory.	Satisfactory but accident study required.
'D'	Operating near capacity.	Near capacity and accident study required.
'E'	At capacity; at signals incidents will cause excessive delays. Roundabouts require other control mode.	At capacity and requires other control mode.
'F'	Unsatisfactory and requires additional capacity.	Unsatisfactory and requires other control mode.

2. *Average Vehicle Delay (AVD)*

The AVD provides a measure of the operational performance of an intersection as indicated on the table below which relates AVD to LOS. The AVD's listed in the table should be taken as a guide only as longer delays could be tolerated in some locations (i.e. inner-city conditions) and on some roads (i.e. minor side street intersecting with a major arterial route).

Level of Service	Average Delay per Vehicle (secs/veh)	Traffic Signals, Roundabout	Give Way and Stop Signs
A	less than 14	Good operation.	Good operation.
B	15 to 28	Good with acceptable delays and spare capacity.	Acceptable delays and spare capacity.
C	29 to 42	Satisfactory.	Satisfactory but accident study required.
D	43 to 56	Operating near capacity.	Near capacity and accident study required.
E	57 to 70	At capacity; at signals incidents will cause excessive delays. Roundabouts require other control mode.	At capacity and requires other control mode.

3. *Degree of Saturation (DS)*

The DS is another measure of the operational performance of individual intersections.

For intersections controlled by traffic signals¹ both queue length and delay increase rapidly as DS approaches 1, and it is usual to attempt to keep DS to less than 0.9. Values of DS in the order of 0.7 generally represent satisfactory intersection operation. When DS exceeds 0.9 queues can be anticipated.

For intersections controlled by a roundabout or GIVE WAY or STOP signs, satisfactory intersection operation is indicated by a DS of 0.8 or less.

¹ The values of DS for intersections under traffic signal control are only valid for cycle length of 120 secs.

4.5 Off-street Parking Assessment

Off-Street Car Parking Provisions

As the development provides *in-fill affordable housing* in accordance with *SEPP (Housing) 2021 Division 1 In-fill affordable housing*, the off-street parking rates applicable to the development proposal are specified in the *State Environmental Planning Policy (Housing) 2021* in the following terms:

Division 1 In-fill affordable housing

19 Non-discretionary development standards—the Act, s 4.15

- (1) The object of this section is to identify development standards for particular matters relating to residential development under this division that, if complied with, prevent the consent authority from requiring more onerous standards for the matters.
- (2) The following are non-discretionary development standards in relation to the residential development to which this division applies—
 - (e) the following number of parking spaces for dwellings used for affordable housing—
 - (i) for each dwelling containing 1 bedroom—at least 0.4 parking spaces,
 - (ii) for each dwelling containing 2 bedrooms—at least 0.5 parking spaces,
 - (iii) for each dwelling containing at least 3 bedrooms—at least 1 parking space,
 - (f) the following number of parking spaces for dwellings not used for affordable housing—
 - (i) for each dwelling containing 1 bedroom—at least 0.5 parking spaces,
 - (ii) for each dwelling containing 2 bedrooms—at least 1 parking space,
 - (iii) for each dwelling containing at least 3 bedrooms—at least 1.5 parking spaces,

In this regard, it should be noted that the *SEPP* does not require off-street parking to be provided for visitors. Notwithstanding, to ensure adequate off-street parking is available for visitors of the development, the *TfNSW Guide to Transport Impact Assessment (TfNSW Guide)* rate of *1 visitor space per 5 dwellings* for residential flat buildings has been adopted.

Application of the above parking rates to the 431 residential apartments outlined in the development proposal yields a total off-street car parking requirement of 556 spaces as set out below:

Affordable Dwellings (SEPP 2021)	Required
1-bedroom (4 dwellings):	1.6 spaces
2-bedroom (21 dwellings):	10.5 spaces
Sub-Total:	12.1 spaces

Standard Dwellings (SEPP 2021)	Required
1-bedroom (37 dwellings):	18.5 spaces
2-bedroom (230 dwellings):	230.0 spaces
3-bedroom (122 dwellings):	183.0 spaces
4-bedroom (17 dwellings):	25.5 spaces
Sub-Total:	457.0 spaces
Visitor Parking (TfNSW)	86.2 spaces
TOTAL PARKING REQUIRED:	555.3 spaces

The proposed development makes provision for a total of 740 off-street car parking spaces, comprising 653 residential spaces and 87 visitor spaces, thereby satisfying the *SEPP (Housing) 2021* requirements.

The geometric design layout of the proposed car parking facilities has been designed to comply with the relevant requirements specified in the Standards Australia publication *Parking Facilities Part 1 - Off-Street Car Parking AS2890.1:2004* and *Parking Facilities Part 6 - Off-Street Parking for People with Disabilities AS2890.6:2009* in respect of parking bay dimensions, aisle & driveway widths, and manoeuvring requirements.

Other Off-Street Parking Provisions

The off-street motorcycle and bicycle parking requirements applicable to the development proposal are specified in *The Hills Development Control Plan 2012, Part D, Section 19 – Showground Station Precinct* document and in *The Hills Development Control Plan 2012, Part C, Section 1 – Parking* document in the following terms:

Table 13 Bicycle Parking Rates

Residential flat buildings:	1 resident space per 3 apartments.
	1 visitor space per 12 apartments.

2.4 Motorcycle Parking

- a) Motorcycle parking is to be provided for all developments with on-site parking of more than 50 car parking spaces, at a rate of 1 motorcycle parking space for every 50 car spaces or part thereof.

Application of the above motorcycle and bicycle parking rates to the 431 apartments outlined in the development proposal yields an off-street motorcycle parking requirement of 15 spaces, and an off-street bicycle parking requirement of 180 spaces as set out below:

Bicycle	
Residential (431 dwellings):	143.7 spaces
Visitor:	35.9 spaces
Total:	179.6 spaces
Motorcycle (740 car spaces):	14.8 spaces
Total:	14.8 spaces

The proposed development makes provision for a total of 32 motorcycle parking spaces and 180 bicycle parking spaces, thereby satisfying the Council's DCP parking requirements.

4.6 Loading/Service Provisions

The proposed development is expected to be serviced by a variety of commercial vehicles up to and including 12.5m long HRV trucks. A loading area is to be located on the ground level adjacent to the waste collection room to accommodate a 12.5m long HRV truck.

The geometric design layout of the proposed loading facilities has been designed to comply with the relevant requirements specified in the Standards Australia publication *Parking Facilities Part 2 - Off-Street Commercial Vehicle Facilities AS2890.2 - 2002* in respect of loading dock dimensions, overhead clearances and service area requirements for HRV trucks.

4.7 Swept Turning Path Analysis

The vehicular access arrangements have been designed to accommodate the swept turning path requirements of the B99 and B85 design vehicles as specified in *AS2890.1*, allowing them to circulate the internal ramps without difficulty, and to enter and exit the site in a forward direction at all times, as demonstrated by the *swept turning path* diagrams reproduced in Appendix C.

The geometric design layout of the proposed vehicular access driveways and internal manoeuvring areas were designed to accommodate the swept turning path requirements of vehicles up to and including 12.5m long Heavy Rigid Vehicles (HRV trucks).

A number of *swept turning path* diagrams have been prepared to assess the turning and manoeuvring requirements of 12.5m long HRV trucks using the *Autodesk Vehicle Tracking 2022* program in accordance with the Standards Australia publication *2890.2-2022*. The *swept turning path* diagrams are reproduced in Appendix C, confirming that these 12.5m long HRV trucks will be able to enter and exit the site in a forward direction at all times, and will be able to manoeuvre within the site without difficulty.

5.0 CONCLUSIONS & RECOMMENDATIONS

This Traffic and Parking Assessment Report has been prepared in accordance with the Planning Secretary's Environmental Assessment Requirements (SEARs), Council's *DCP/LEP* and the TfNSW *Guide*, to accompany an Environmental Impact Statement to the *NSW Department of Planning, Infrastructure and Environment* for a proposed residential development.

The parking requirements of the proposed development have been designed in accordance with *SEPP (Housing) 2021*, *The Hills LEP 2019*, *The Hills DCP 2012*, and the *Urban Design Guidelines*.

The proposed provision of 740 car parking spaces, 32 motorcycle parking spaces and 180 bicycle parking spaces are considered sufficient to satisfy the anticipated *actual* parking likely to be generated by the development to ensure its viability.

It is clear that the site has excellent connectivity to public transport services including the Sydney Metro service, and is ideally located to encourage a greater use of alternate, and sustainable modes of transport.

Extensive traffic surveys and SIDRA modelling were also undertaken at the following intersections in 2024:

- Carrington Road & Middleton Avenue & Andalusian Way
- Middleton Avenue & Patridge Avenue
- Middleton Avenue & Fishburn Crescent

The SIDRA analysis confirmed that the surrounding road network will continue to operate at satisfactory *Levels of Service*, and that the proposed development will not result in any unacceptable traffic implications in terms of road network capacity.

In particular, the SIDRA capacity analysis has confirmed that no new road improvements or intersection upgrades will be required as a consequence of the development proposal.

In terms of the geometric design of the vehicular access, parking and loading facilities, the proposed layout has been designed in accordance with the *AS2890* series. Importantly, all vehicles are able to enter and exit the site in a forward direction at all times.

Accordingly, it is clear that the proposed development will not have any unacceptable traffic or parking implications, and is therefore recommended for approval.

APPENDIX A

TRAFFIC SURVEY DATA

Intersection of Carrington Rd and Andalusian Way, Castle Hill

GPS: -33.727033, 150.900170

Date:	Wed 01/05/24
Weather:	Overcast
Suburban:	Castle Hill
Customer:	Varga

North:	Andalusian Way
East:	Carrington Rd
South:	Middleton Ave
West:	Carrington Rd

Survey	AM: 8:30 AM-9:30 AM
Period	PM: 3:30 PM-6:30 PM
Traffic	AM: 8:00 AM-9:00 AM
Peak	PM: 5:00 PM-6:00 PM

All Vehicles

Time		North Approach Andalusian Way				East Approach Carrington Rd				South Approach Middleton Ave				West Approach Carrington Rd				Hourly Total	
Period Start	Period End	U	R	SB	L	U	R	WB	L	U	R	NB	L	U	R	EB	L	Hour	Peak
6:30	6:45	0	5	0	0	0	2	46	9	0	7	14	15	0	14	33	3	747	
6:45	7:00	0	0	2	0	0	2	64	8	0	8	17	13	0	15	33	6	895	
7:00	7:15	0	3	2	2	0	2	68	11	0	2	21	17	0	15	42	7	1082	
7:15	7:30	0	7	5	1	0	6	98	14	0	7	13	22	0	24	39	3	1243	
7:30	7:45	0	11	8	6	0	4	100	19	0	15	16	26	0	29	57	5	1375	
7:45	8:00	0	14	7	4	0	1	122	20	0	20	15	43	0	25	73	11	1476	
8:00	8:15	0	16	14	4	0	3	113	19	0	27	15	41	0	32	59	10	1489	Peak
8:15	8:30	0	6	4	3	0	1	141	29	0	36	14	27	0	31	76	3	1450	
8:30	8:45	0	5	4	3	0	3	152	31	0	55	12	42	0	34	56	0	1374	
8:45	9:00	0	11	3	2	0	1	159	29	0	27	5	48	0	13	69	1		
9:00	9:15	0	10	8	3	0	1	130	24	0	14	8	30	0	17	63	6		
9:15	9:30	0	8	6	5	0	0	106	28	0	16	11	26	0	30	58	1		
15:30	15:45	0	19	9	5	0	3	142	20	0	24	13	39	0	23	105	12	1656	
15:45	16:00	0	14	8	3	0	3	157	28	0	22	18	45	0	33	94	3	1625	
16:00	16:15	0	8	11	2	0	0	142	18	0	19	11	31	0	31	140	5	1590	
16:15	16:30	0	5	5	3	0	1	113	26	0	22	15	28	0	36	136	6	1585	
16:30	16:45	0	12	5	4	0	0	102	21	0	23	9	29	0	39	133	6	1612	
16:45	17:00	0	7	7	4	0	2	98	21	0	24	14	33	0	31	152	0	1630	
17:00	17:15	0	8	15	9	0	4	81	20	0	32	10	42	0	49	140	3	1668	Peak
17:15	17:30	0	6	9	5	0	1	137	21	0	31	13	37	0	29	132	2	1601	
17:30	17:45	0	19	11	3	0	1	104	22	0	55	31	21	0	30	96	8	1536	
17:45	18:00	0	13	7	4	0	2	122	19	0	60	32	21	0	22	126	3		
18:00	18:15	0	10	4	3	0	2	88	14	0	23	18	27	0	28	125	4		
18:15	18:30	0	5	7	3	0	2	91	11	0	26	16	22	0	27	140	8		

Peak Time	North Approach Andalusian Way				East Approach Carrington Rd				South Approach Middleton Ave				West Approach Carrington Rd				Peak total		
Period Start	Period End	U	R	SB	L	U	R	WB	L	U	R	NB	L	U	R	EB	L		
8:00	9:00	0	38	25	12	0	8	565	108	0	145	46	158	0	110	260	14	1489	
17:00	18:00	0	46	42	21	0	8	444	82	0	178	86	121	0	130	494	16	1668	

Pedestrians Crossing

Time		Approach Andalusian Way		Approach Carrington Rd		Approach Middleton Ave		Approach Carrington Rd		Pedestrians To
Period Start	Period End	Westbound	Eastbound	Southbound	Northbound	Westbound	Eastbound	Southbound	Northbound	
6:30	6:45	1	15	0	0	1	0	1	7	91
6:45	7:00	4	3	0	0	1	0	3	9	105
7:00	7:15	2	1	0	0	2	0	0	11	124
7:15	7:30	4	2	0	0	5	0	1	18	146
7:30	7:45	12	1	0	0	4	0	1	21	160
7:45	8:00	10	2	0	0	4	0	1	22	149
8:00	8:15	8	0	0	0	6	0	3	21	130
8:15	8:30	11	1	0	0	5	1	3	23	114
8:30	8:45	3	0	0	0	10	0	0	15	83
8:45	9:00	4	2	0	0	3	0	0	11	
9:00	9:15	4	2	0	0	3	0	1	12	
9:15	9:30	5	0	0	0	0	0	2	6	
15:30	15:45	1	5	0	0	0	3	10	4	83
15:45	16:00	0	3	0	0	0	0	12	4	77
16:00	16:15	2	6	0	0	0	3	13	4	81
16:15	16:30	1	5	0	0	0	0	5	2	72
16:30	16:45	1	4	0	0	0	3	7	2	83
16:45	17:00	0	5	0	0	2	2	12	2	100
17:00	17:15	1	4	0	0	0	2	9	3	101
17:15	17:30	3	5	0	0	0	4	10	2	96
17:30	17:45	0	3	0	0	1	7	20	3	100
17:45	18:00	0	5	0	0	1	3	14	1	
18:00	18:15	1	3	0	0	0	1	9	0	
18:15	18:30	1	3	0	0	1	7	13	3	

Peak Time	Approach Andalusian Way		Approach Carrington Rd		Approach Middleton Ave		Approach Carrington Rd		Peak hour	
Period Start	Period End	Westbound	Eastbound	Southbound	Northbound	Westbound	Eastbound	Southbound	Northbound	
8:00	9:00	26	3	0	0	24	1	6	70	130
17:00	18:00	4	17	0	0	2	16	53	9	101

Note: Site sketch is for illustrating traffic flows. Direction is indicative only, drawing is not to scale and not an exact streets configuration.

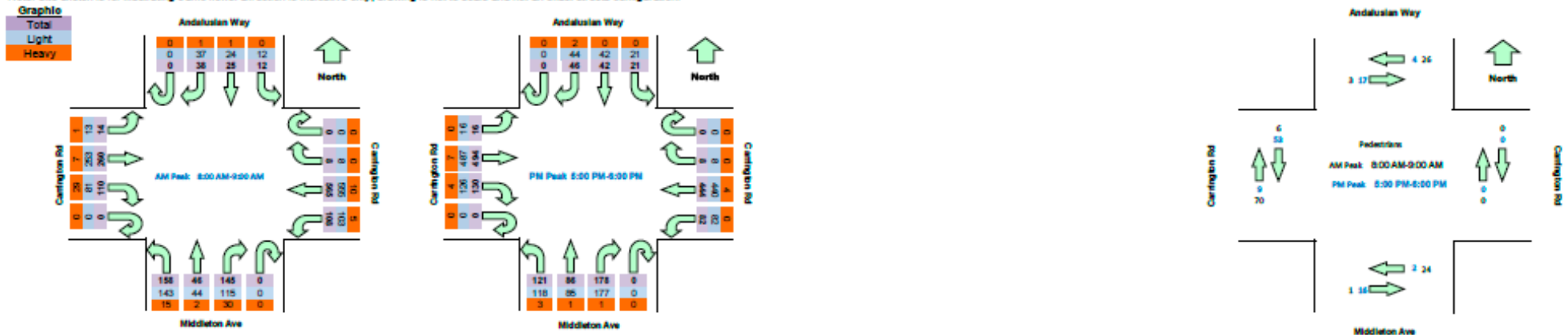

Light Vehicles

Time		North Approach Andalusian Way				East Approach Carrington Rd				South Approach Middleton Ave				West Approach Carrington Rd			
Period Start	Period End	U	R	SB	L	U	R	WB	L	U	R	NB	L	U	R	EB	L
6:30	6:45	0	5	0	0	0	2	44	8	0	7	13	14	0	13	32	2
6:45	7:00	0	0	2	0	0	2	63	7	0	8	17	12	0	12	31	6
7:00	7:15	0	3	2	1	0	2	66	11	0	2	21	15	0	14	38	6
7:15	7:30	0	7	5	1	0	6	96	13	0	7	13	20	0	19	36	3
7:30	7:45	0	11	7	6	0	4	95	19	0	13	16	23	0	12	57	4
7:45	8:00	0	13	7	4	0	1	122	19	0	13	13	40	0	20	72	10
8:00	8:15	0	16	13	4	0	3	109	18	0	19	14	33	0	21	57	9
8:15	8:30	0	6	4	3	0	1	140	27	0	27	13	26	0	21	76	3
8:30	8:45	0	5	4	3	0	3	150	30	0	50	12	40	0	26	55	0
8:45	9:00	0	10	3	2	0	1	156	28	0	19	5	44	0	13	65	1
9:00	9:15	0	9	8	3	0	1	128	24	0	11	8	27	0	14	59	6
9:15	9:30	0	7	5	5	0	0	104	24	0	14	10	24	0	27	53	1
15:30	15:45	0	18	9	4	0	3	142	17	0	21	13	37	0	22	104	12
15:45	16:00	0	13	8	3	0	3	150	28	0	22	18	41	0	32	94	3
16:00	16:15	0	8	11	2	0	0	142	18	0	18	11	30	0	30	138	5
16:15	16:30	0	5	5	3	0	1	112	26	0	21	15	28	0	35	136	5
16:30	16:45	0	11	5	4	0	0	101	21	0	22	9	28	0	39	132	6
16:45	17:00	0	7	7	4	0	2	95	21	0	24	14	31	0	30	151	0
17:00	17:15	0	8	15	9	0	4	79	20	0	32	9	41	0	48	139	3
17:15	17:30	0	5	9	5	0	1	136	21	0	30	13	36	0	28	131	2
17:30	17:45	0	18	11	3	0	1	103	22	0	55	31	20	0	29	93	8
17:45	18:00	0	13	7	4	0	2	122	19	0	60	32	21	0	21	124	3
18:00	18:15	0	10	4	3	0	2	88	14	0	23	18	27	0	27	124	4
18:15	18:30	0	5	7	3	0	2	91	11	0	26	16	20	0	26	139	8

Peak Time		North Approach Andalusian Way				East Approach Carrington Rd				South Approach Middleton Ave				West Approach Carrington Rd				Peak total
Period Start	Period End	U	R	SB	L	U	R	WB	L	U	R	NB	L	U	R	EB	L	
8:00	9:00	0	37	24	12	0	8	555	103	0	115	44	143	0	81	253	13	1388
17:00	18:00	0	44	42	21	0	8	440	82	0	177	85	118	0	126	487	16	1646

Heavy Vehicles

Time		North Approach Andalusian Way				East Approach Carrington Rd				South Approach Middleton Ave				West Approach Carrington Rd			
Period Start	Period End	U	R	SB	L	U	R	WB	L	U	R	NB	L	U	R	EB	L
6:30	6:45	0	0	0	0	0	0	2	1	0	0	1	1	0	1	1	1
6:45	7:00	0	0	0	0	0	0	1	1	0	0	0	1	0	3	2	0
7:00	7:15	0	0	0	1	0	0	2	0	0	0	0	2	0	1	4	1
7:15	7:30	0	0	0	0	0	0	2	1	0	0	0	2	0	5	3	0
7:30	7:45	0	0	1	0	0	0	5	0	0	2	0	3	0	17	0	1
7:45	8:00	0	1	0	0	0	0	0	1	0	7	2	3	0	5	1	1
8:00	8:15	0	0	1	0	0	0	4	1	0	8	1	8	0	11	2	1
8:15	8:30	0	0	0	0	0	0	1	2	0	9	1	1	0	10	0	0
8:30	8:45	0	0	0	0	0	0	2	1	0	5	0	2	0	8	1	0
8:45	9:00	0	1	0	0	0	0	3	1	0	8	0	4	0	0	4	0
9:00	9:15	0	1	0	0	0	0	2	0	0	3	0	3	0	3	4	0
9:15	9:30	0	1	1	0	0	0	2	4	0	2	1	2	0	3	5	0
15:30	15:45	0	1	0	1	0	0	3	0	3	0	2	0	1	1	0	0
15:45	16:00	0	1	0	0	0	0	7	0	0	0	0	4	0	1	0	0
16:00	16:15	0	0	0	0	0	0	0	0	1	0	1	0	1	2	0	0
16:15	16:30	0	0	0	0	0	0	1	0	0	1	0	0	0	1	0	1
16:30	16:45	0	1	0	0	0	0	1	0	0	1	0	1	0	0	1	0
16:45	17:00	0	0	0	0	0	0	3	0	0	0	0	2	0	1	1	0
17:00	17:15	0	0	0	0	0	0	2	0	0	0	1	1	0	1	1	0
17:15	17:30	0	1	0	0	0	0	1	0	0	1	0	1	0	1	1	0
17:30	17:45	0	1	0	0	0	0	1	0	0	0	0	1	0	1	3	0
17:45	18:00	0	0	0	0	0	0	0	0	0	0	0	0	0	1	2	0
18:00	18:15	0	0	0	0	0	0	0	0	0	0	0	0	0	1	1	0
18:15	18:30	0	0	0	0	0	0	0	0	0	0	0	2	0	1	1	0

Peak Time		North Approach Andalusian Way				East Approach Carrington Rd				South Approach Middleton Ave				West Approach Carrington Rd				Peak total
Period Start	Period End	U	R	SB	L	U	R	WB	L	U	R	NB	L	U	R	EB	L	
8:00	9:00	0	1	1	0	0	0	10	5	0	30	2	15	0	29	7	1	101
17:00	18:00	0	2	0	0	0	0	4	0	0	1	1	3	0	4	7	0	22

TRANS TRAFFIC SURVEY

TURNING MOVEMENT SURVEY



Intersection of Partridge Ave and Middleton Ave, Castle

GPS -33.72892, 160.988495

Date:	Wed 01/05/24
Weather:	Overcast
Suburban:	Castle Hill
Customer:	Varga

North:	Middleton Ave
East:	N/A
South:	Middleton Ave
West:	Partridge Ave

Survey Period	AM: 6:30 AM-9:30 AM
	PM: 3:30 PM-6:30 PM
Traffic Peak	AM: 7:45 AM-8:45 AM
	PM: 5:00 PM-6:00 PM

All Vehicles

Time		North Approach Middleton Ave			East Approach Middleton Ave			West Approach Partridge Ave			Hourly Total	
Period Start	Period End	U	R	SB	U	NB	L	U	R	L	Hour	Peak
6:30	6:45	0	5	18	0	34	3	0	0	2	284	
6:45	7:00	0	8	17	0	34	3	0	0	2	336	
7:00	7:15	0	3	25	0	39	0	0	0	1	401	
7:15	7:30	0	2	41	0	42	1	0	1	1	481	
7:30	7:45	0	1	55	0	54	2	0	1	3	534	
7:45	8:00	0	3	49	0	74	1	0	0	2	598	Peak
8:00	8:15	0	3	62	0	80	1	0	0	2	594	
8:15	8:30	0	6	56	0	79	0	0	0	0	545	
8:30	8:45	0	4	64	0	102	2	0	2	6	518	
8:45	9:00	1	2	43	1	74	1	0	0	3		
9:00	9:15	1	5	43	0	48	1	0	0	1		
9:15	9:30	0	3	59	0	50	0	0	0	2		
15:30	15:45	2	2	48	0	69	0	0	0	7	537	
15:45	16:00	0	2	65	0	79	0	0	0	2	535	
16:00	16:15	0	5	57	1	59	1	0	0	4	516	
16:15	16:30	0	4	63	0	61	1	0	2	3	559	
16:30	16:45	1	2	60	0	60	1	0	1	1	563	
16:45	17:00	0	5	56	0	64	0	0	0	4	605	
17:00	17:15	1	1	82	0	82	0	0	0	4	636	Peak
17:15	17:30	0	4	55	0	77	0	0	0	2	579	
17:30	17:45	1	2	59	0	104	0	0	0	2	550	
17:45	18:00	0	2	44	0	109	0	0	1	4		
18:00	18:15	0	1	45	0	66	0	0	0	1		
18:15	18:30	0	0	46	0	58	0	0	0	5		

Peak Time		North Approach Middleton Ave			East Approach Middleton Ave			West Approach Partridge Ave			Peak total
Period Start	Period End	U	R	SB	U	NB	L	U	R	L	total
7:45	8:45	0	16	231	0	335	4	0	2	10	598
17:00	18:00	2	9	240	0	372	0	0	1	12	636

Pedestrians Crossing

Time		Approach Middle		Approach Middle		Approach Partridge		Hourly Total
Period Start	Period End	Westbound	Eastbound	Westbound	Eastbound	Southbound	Northbound	
6:30	6:45	1	0	0	0	0	2	20
6:45	7:00	0	1	1	0	1	3	32
7:00	7:15	3	0	0	0	0	1	45
7:15	7:30	3	0	1	0	0	3	52
7:30	7:45	7	0	0	0	1	7	61
7:45	8:00	3	1	3	0	1	11	53
8:00	8:15	2	0	2	0	1	6	42
8:15	8:30	10	0	1	0	2	3	37
8:30	8:45	0	0	1	1	0	5	24
8:45	9:00	0	1	2	0	0	5	
9:00	9:15	4	0	0	0	1	1	
9:15	9:30	1	0	0	0	0	2	
15:30	15:45	2	4	0	1	5	0	36
15:45	16:00	0	2	0	2	7	2	31
16:00	16:15	0	0	0	0	2	2	21
16:15	16:30	0	0	0	0	5	2	26
16:30	16:45	0	3	2	0	1	1	22
16:45	17:00	0	1	0	0	2	0	35
17:00	17:15	0	2	0	0	3	4	37
17:15	17:30	1	2	0	0	0	0	32
17:30	17:45	2	4	0	0	13	1	33
17:45	18:00	0	0	0	1	4	0	
18:00	18:15	0	1	0	0	3	0	
18:15	18:30	0	1	0	0	3	0	

Peak Time		Approach Middle		Approach Middle		Approach Partridge		Peak total
Period Start	Period End	Westbound	Eastbound	Westbound	Eastbound	Southbound	Northbound	total
7:45	8:45	15	1	7	1	4	25	53
17:00	18:00	3	8	0	1	20	5	37

Note: Site sketch is for illustrating traffic flows. Direction is indicative only, drawing is not to scale and not an exact streets configuration.

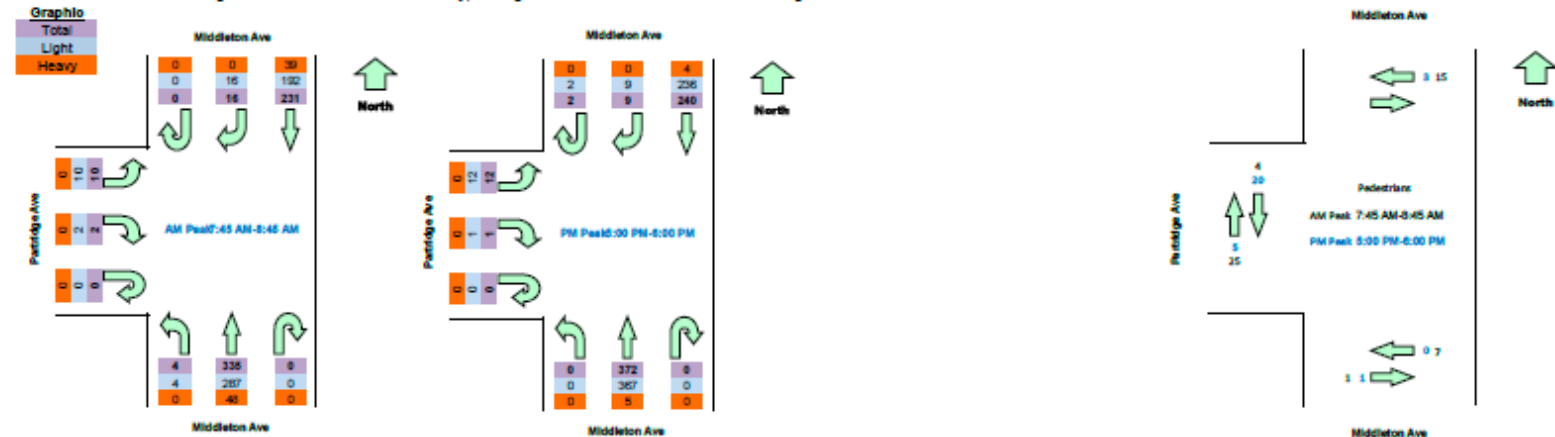

Light Vehicles

Time		North Approach Middleton			South Approach Middleton			West Approach Partridge A		
Period Start	Period End	U	R	SB	U	NB	L	U	R	L
6:30	6:45	0	5	16	0	32	3	0	0	4
6:45	7:00	0	8	13	0	33	3	0	0	2
7:00	7:15	0	3	24	0	37	0	0	0	1
7:15	7:30	0	2	35	0	40	1	0	1	1
7:30	7:45	0	1	37	0	49	2	0	1	3
7:45	8:00	0	3	43	0	62	1	0	0	2
8:00	8:15	0	3	49	0	63	1	0	0	2
8:15	8:30	0	6	45	0	68	0	0	0	0
8:30	8:45	0	4	55	0	94	2	0	2	6
8:45	9:00	1	2	41	1	63	1	0	0	3
9:00	9:15	1	5	40	0	42	1	0	0	1
9:15	9:30	0	2	52	0	46	0	0	0	1
15:30	15:45	2	2	44	0	63	0	0	0	7
15:45	16:00	0	2	64	0	76	0	0	0	2
16:00	16:15	0	5	56	1	57	1	0	0	4
16:15	16:30	0	4	62	0	60	1	0	2	3
16:30	16:45	1	2	60	0	58	1	0	1	1
16:45	17:00	0	5	55	0	62	0	0	0	4
17:00	17:15	1	1	81	0	80	0	0	0	4
17:15	17:30	0	4	54	0	75	0	0	0	2
17:30	17:45	1	2	58	0	103	0	0	0	2
17:45	18:00	0	2	43	0	109	0	0	1	4
18:00	18:15	0	1	44	0	66	0	0	0	1
18:15	18:30	0	0	45	0	56	0	0	0	5

Peak Time		North Approach Middleton			South Approach Middleton			West Approach Partridge A			Peak total
Period Start	Period End	U	R	SB	U	NB	L	U	R	L	
7:45	8:45	0	16	192	0	287	4	0	2	10	511
17:00	18:00	2	9	236	0	367	0	0	1	12	627

Heavy Vehicles

Time		North Approach Middleton			South Approach Middleton			West Approach Partridge A		
Period Start	Period End	U	R	SB	U	NB	L	U	R	L
6:30	6:45	0	0	2	0	2	0	0	0	0
6:45	7:00	0	0	4	0	1	0	0	0	0
7:00	7:15	0	0	1	0	2	0	0	0	0
7:15	7:30	0	0	6	0	2	0	0	0	0
7:30	7:45	0	0	18	0	5	0	0	0	0
7:45	8:00	0	0	6	0	12	0	0	0	0
8:00	8:15	0	0	13	0	17	0	0	0	0
8:15	8:30	0	0	11	0	11	0	0	0	0
8:30	8:45	0	0	9	0	8	0	0	0	0
8:45	9:00	0	0	2	0	11	0	0	0	0
9:00	9:15	0	0	3	0	6	0	0	0	0
9:15	9:30	0	1	7	0	4	0	0	0	1
15:30	15:45	0	0	4	0	6	0	0	0	0
15:45	16:00	0	0	1	0	3	0	0	0	0
16:00	16:15	0	0	1	0	2	0	0	0	0
16:15	16:30	0	0	1	0	1	0	0	0	0
16:30	16:45	0	0	0	0	2	0	0	0	0
16:45	17:00	0	0	1	0	2	0	0	0	0
17:00	17:15	0	0	1	0	2	0	0	0	0
17:15	17:30	0	0	1	0	2	0	0	0	0
17:30	17:45	0	0	1	0	1	0	0	0	0
17:45	18:00	0	0	1	0	0	0	0	0	0
18:00	18:15	0	0	1	0	0	0	0	0	0
18:15	18:30	0	0	1	0	2	0	0	0	0

Peak Time		North Approach Middleton			South Approach Middleton			West Approach Partridge A			Peak total
Period Start	Period End	U	R	SB	U	NB	L	U	R	L	
7:45	8:45	0	0	39	0	48	0	0	0	0	87
17:00	18:00	0	0	4	0	5	0	0	0	0	9

Intersection of Middleton Ave and Fishburn Cres, Castle

GPS: -33.729204, 150.908770

Date:	Wed 01/05/24
Weather:	Overcast
Suburban:	Castle Hill
Customer:	Varga
North:	Middleton Ave
East:	Fishburn Cres
South:	Middleton Ave
West:	N/A

Survey	AM:	6:30 AM-9:30 AM
Period	PM:	3:30 PM-6:30 PM
Traffic	AM:	7:45 AM-9:45 AM
Peak	PM:	5:00 PM-6:00 PM

All Vehicles

Time		North Approach Middleton Ave			East Approach Fishburn Cres			South Approach Middleton Ave			Hourly Total	Peak
Period Start	Period End	U	SB	L	U	R	L	U	R	NB	Hour	Peak
6:30	6:45	0	14	4	0	2	0	0	8	37	283	
6:45	7:00	0	10	7	0	3	1	0	3	32	338	
7:00	7:15	0	23	3	0	4	1	0	5	36	412	
7:15	7:30	0	37	5	0	3	2	0	3	40	486	
7:30	7:45	0	36	21	0	4	1	1	4	53	537	
7:45	8:00	0	46	4	0	3	3	0	2	72	592	Peak
8:00	8:15	0	45	17	0	4	0	0	3	77	596	
8:15	8:30	0	48	8	0	5	2	0	3	75	534	
8:30	8:45	0	50	16	0	5	1	1	4	98	506	
8:45	9:00	0	39	5	0	5	1	0	3	71		
9:00	9:15	0	39	3	0	6	2	0	1	43		
9:15	9:30	0	43	17	0	2	1	0	2	48		
15:30	15:45	0	41	7	0	8	2	1	0	61	520	
15:45	16:00	0	58	6	0	6	3	0	1	71	529	
16:00	16:15	0	52	6	0	5	1	0	1	58	513	
16:15	16:30	0	57	9	0	7	3	0	1	55	556	
16:30	16:45	0	54	7	0	8	4	1	1	54	559	
16:45	17:00	0	50	6	0	4	6	0	4	59	596	
17:00	17:15	1	72	9	0	6	3	0	0	75	626	Peak
17:15	17:30	0	53	2	0	7	3	0	1	69	574	
17:30	17:45	0	51	8	0	10	2	0	1	94	541	
17:45	18:00	0	41	4	0	5	2	1	2	104		
18:00	18:15	0	39	6	0	7	1	0	2	59		
18:15	18:30	0	42	4	0	6	0	0	0	50		

Peak Time		North Approach Middleton Ave			East Approach Fishburn Cres			South Approach Middleton Ave			Peak total
Period Start	Period End	U	SB	L	U	R	L	U	R	NB	Peak total
7:45	8:45	0	189	45	0	17	6	1	12	322	592
17:00	18:00	1	217	23	0	28	10	1	4	342	626

Pedestrians Crossing

Time		Approach Middleton Ave		Approach Fishburn Cres		Approach Middleton Ave		Hourly Total
Period Start	Period End	Westbound	Eastbound	Northbound	Southbound	Westbound	Eastbound	Hourly Total
6:30	6:45	1	0	9	1	0	0	55
6:45	7:00	0	0	8	1	0	0	67
7:00	7:15	0	0	9	0	2	0	81
7:15	7:30	0	0	22	2	0	0	91
7:30	7:45	0	0	19	4	0	0	99
7:45	8:00	0	0	22	1	0	0	92
8:00	8:15	0	0	18	1	2	0	76
8:15	8:30	0	0	29	3	0	0	62
8:30	8:45	0	0	14	2	0	0	35
8:45	9:00	0	0	6	1	0	0	
9:00	9:15	0	0	7	0	0	0	
9:15	9:30	0	0	3	2	0	0	
15:30	15:45	0	0	2	8	0	0	33
15:45	16:00	0	0	2	8	0	0	36
16:00	16:15	0	0	0	5	1	0	35
16:15	16:30	0	0	1	5	0	1	36
16:30	16:45	0	0	3	10	0	0	37
16:45	17:00	0	0	3	6	0	0	40
17:00	17:15	0	0	0	7	0	0	46
17:15	17:30	0	0	2	6	0	0	49
17:30	17:45	0	0	1	15	0	0	56
17:45	18:00	0	0	0	15	0	0	
18:00	18:15	0	0	0	10	0	0	
18:15	18:30	0	0	4	11	0	0	

Peak Time		Approach Middleton Ave		Approach Fishburn Cres		Approach Middleton Ave		Peak total
Period Start	Period End	Westbound	Eastbound	Northbound	Southbound	Westbound	Eastbound	Peak total
7:45	8:45	0	0	83	7	2	0	92
17:00	18:00	0	0	3	43	0	0	46

Note: Site sketch is for illustrating traffic flows. Direction is indicative only, drawing is not to scale and not an exact streets configuration.

Graphs

Total
Light
Heavy

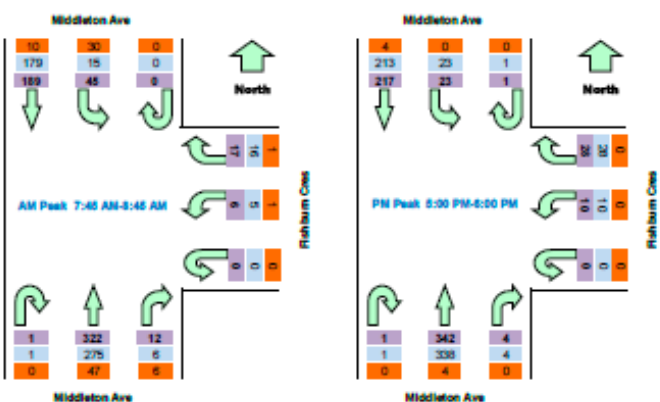

Middleton Ave

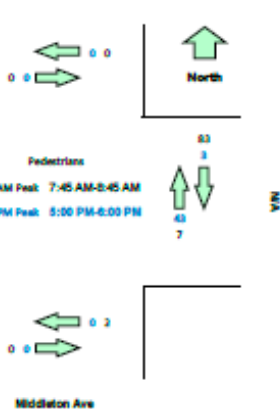

APPENDIX B

SIDRA MOVEMENT SUMMARIES

NETWORK LAYOUT

■ ■ Network: N101 [AM Network (Network Folder: Existing)]

New Network
 Network Category: (None)

Layout pictures are schematic functional drawings reflecting input data. They are not design drawings.

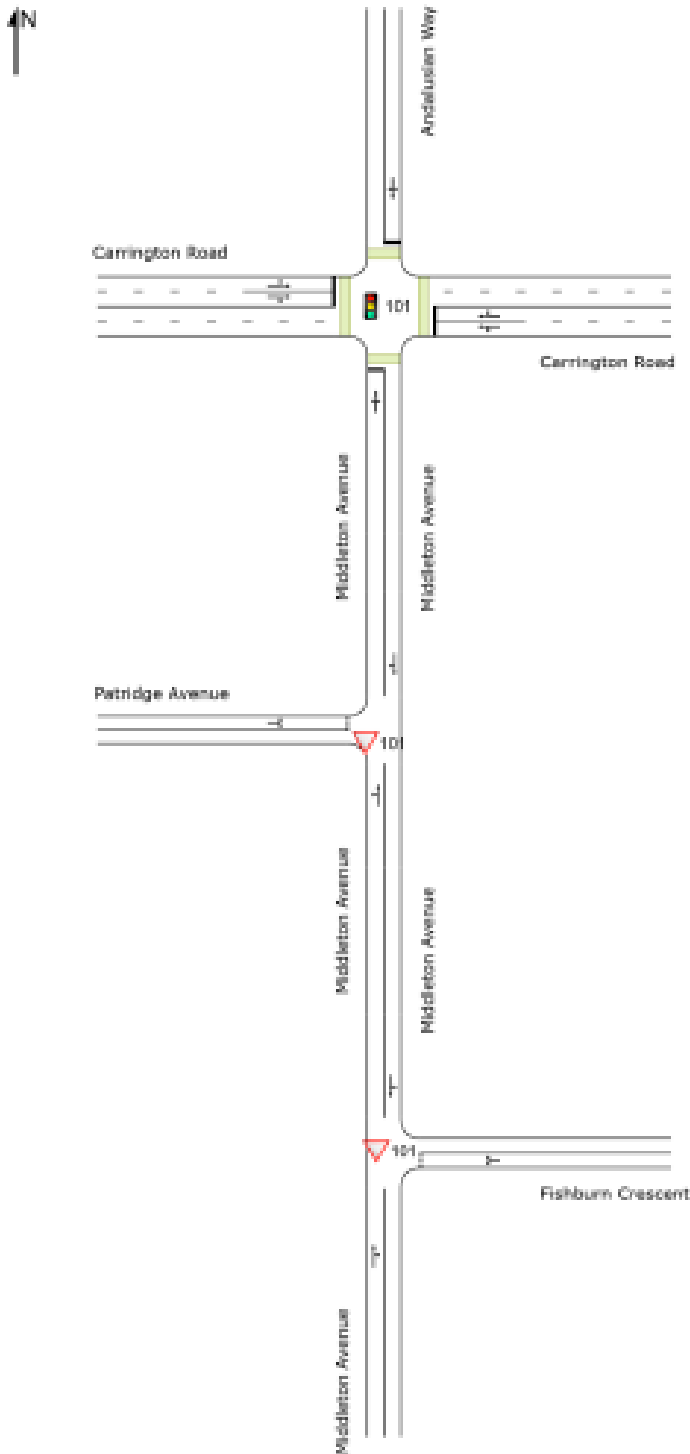

SITES IN NETWORK		
Site ID	CCG ID	Site Name
101	NA	AM Peak Carrington Rd & Middleton Ave & Andalusian Way
101	NA	AM Peak Middleton Ave & Patridge Ave
101	NA	AM Peak Middleton Ave & Fishburn Cres

MOVEMENT SUMMARY

Site: 101 [AM Peak Carrington Rd & Middleton Ave & Andalusian Way (Site Folder: Existing)]

Network: N101 [AM Network (Network Folder: Existing)]

16 Carrington Rd, Castle Hill

Site Category: (None)

Signals - EQUISAT (Fixed-Time/SCATS) Isolated Cycle Time = 120 seconds (Site User-Given Cycle Time)

Vehicle Movement Performance														
Mov ID	Turn	DEMAND FLOWS		ARRIVAL FLOWS		Deg. Satn v/c	Aver. Delay sec	Level of Service	AVERAGE BACK OF QUEUE		Prop. Que	Effective Stop Rate	Aver. No. Cycles	Aver. Speed km/h
		[Total veh/h]	HV %	[Total veh/h]	HV %				[Veh. veh]	[Dist. m]				
South: Middleton Avenue														
1	L2	166	9.5	166	9.5	0.539	31.0	LOS C	9.6	75.2	0.79	0.79	0.79	17.9
2	T1	48	4.3	48	4.3	0.539	26.3	LOS B	9.6	75.2	0.79	0.79	0.79	18.9
3	R2	153	20.7	153	20.7	+0.539	31.1	LOS C	9.6	75.2	0.79	0.79	0.79	22.6
Approach		367	13.5	367	13.5	0.539	30.4	LOS C	9.6	75.2	0.79	0.79	0.79	20.2
East: Carrington Road														
4	L2	114	4.6	114	4.6	0.417	27.7	LOS B	8.5	61.2	0.72	0.67	0.72	22.2
5	T1	595	1.8	595	1.8	0.417	23.1	LOS B	8.5	61.2	0.72	0.65	0.72	27.7
6	R2	8	0.0	8	0.0	0.417	27.7	LOS B	8.5	60.1	0.72	0.63	0.72	27.8
Approach		717	2.2	717	2.2	0.417	23.9	LOS B	8.5	61.2	0.72	0.65	0.72	27.0
North: Andalusian Way														
7	L2	13	0.0	13	0.0	0.146	31.1	LOS C	1.9	13.3	0.70	0.67	0.70	25.1
8	T1	26	4.0	26	4.0	0.146	26.5	LOS B	1.9	13.3	0.70	0.67	0.70	14.3
9	R2	40	2.6	40	2.6	0.146	31.1	LOS C	1.9	13.3	0.70	0.67	0.70	20.8
Approach		79	2.7	79	2.7	0.146	29.6	LOS C	1.9	13.3	0.70	0.67	0.70	19.8
West: Carrington Road														
10	L2	15	7.1	15	7.1	0.330	26.6	LOS B	6.5	46.7	0.68	0.59	0.68	23.9
11	T1	274	2.7	274	2.7	0.330	22.0	LOS B	6.5	46.7	0.68	0.59	0.68	28.5
12	R2	116	26.4	116	26.4	+0.537	41.4	LOS C	3.5	30.3	0.86	0.80	0.86	10.6
Approach		404	9.6	404	9.6	0.537	27.7	LOS B	6.5	46.7	0.73	0.65	0.73	23.2
All Vehicles		1567	6.8	1567	6.8	0.539	26.7	LOS B	9.6	75.2	0.74	0.68	0.74	24.0

Site Level of Service (LOS) Method: Delay (RTA NSW). Site LOS Method is specified in the Network Data dialog (Network tab).

Vehicle movement LOS values are based on average delay per movement.

Intersection and Approach LOS values are based on average delay for all vehicle movements.

Delay Model: SIDRA Standard (Geometric Delay is Included).

Gap-Acceptance Capacity: SIDRA Standard (Alkpelik M3D).

HV (%) values are calculated for All Movement Classes of All Heavy Vehicle Model Designation.

+ Critical Movement (Signal Timing)

Pedestrian Movement Performance											
Mov ID	Crossing	Dem. Flow ped/h	Aver. Delay sec	Level of Service	AVERAGE BACK OF QUEUE		Prop. Que	Effective Stop Rate	Travel Time sec	Travel Dist. m	Aver. Speed m/sec
					[Ped ped]	[Dist. m]					
South: Middleton Avenue											
P1	Full	26	54.2	LOS E	0.1	0.1	0.95	0.95	215.1	209.2	0.97
East: Carrington Road											
P2	Full	1	54.2	LOS E	0.0	0.0	0.95	0.95	219.7	215.2	0.98
North: Andalusian Way											
P3	Full	31	54.2	LOS E	0.1	0.1	0.95	0.95	215.1	209.2	0.97
West: Carrington Road											

P4 Full	80	54.3	LOS E	0.3	0.3	0.95	0.95	219.9	215.2	0.98
All Pedestrians	138	54.3	LOS E	0.3	0.3	0.95	0.95	217.9	212.7	0.98

Level of Service (LOS) Method: SIDRA Pedestrian LOS Method (Based on Average Delay)

Pedestrian movement LOS values are based on average delay per pedestrian movement.

Intersection LOS value for Pedestrians is based on average delay for all pedestrian movements.

SIDRA INTERSECTION 8.0 | Copyright © 2000-2020 Akcelik and Associates Pty Ltd | sidracolutions.com

Organisation: VARGA TRAFFIC PLANNING | Licence: NETWORK / 1PC | Processed: Friday, 10 May 2024 1:38:37 PM

Project: Z:\DATA\Data\Jobs\01\Jobs\23\work\23513_16\CamingtonRdCastleHill\SIDRA\240510_SIDRA.sip9

MOVEMENT SUMMARY

Site: 101 [AM Peak Middleton Ave & Patridge Ave (Site Folder: Existing)]

Network: N101 [AM Network (Network Folder: Existing)]

16 Carrington Rd, Castle Hill
 Site Category: (None)
 Give-Way (Two-Way)

Vehicle Movement Performance														
Mov ID	Turn	DEMAND FLOWS		ARRIVAL FLOWS		Deg. Satn w/c	Aver. Delay sec	Level of Service	AVERAGE BACK OF QUEUE		Prop. Que	Effective Stop Rate	Aver. No. Cycles	Aver. Speed km/h
		[Total veh/h]	[HV %]	[Total veh/h]	[HV %]				[Veh. veh]	[Dist m]				
South: Middleton Avenue														
1	L2	4	0.0	4	0.0	0.293	4.6	LOS A	0.0	0.0	0.00	0.01	0.00	48.9
2	T1	353	14.0	353	14.0	0.293	0.0	LOS A	0.0	0.0	0.00	0.01	0.00	49.3
Approach		357	13.9	357	13.9	0.293	0.1	NA	0.0	0.0	0.00	0.01	0.00	49.2
North: Middleton Avenue														
8	T1	237	15.6	237	15.6	0.144	0.1	LOS A	0.0	0.4	0.05	0.04	0.05	46.3
9	R2	16	0.0	16	0.0	0.144	6.1	LOS A	0.0	0.4	0.05	0.04	0.05	47.8
Approach		253	14.6	253	14.6	0.144	0.5	NA	0.0	0.4	0.05	0.04	0.05	46.7
West: Patridge Avenue														
10	L2	12	0.0	12	0.0	0.019	5.8	LOS A	0.0	0.1	0.41	0.58	0.41	42.8
12	R2	2	0.0	2	0.0	0.019	7.3	LOS A	0.0	0.1	0.41	0.58	0.41	42.8
Approach		14	0.0	14	0.0	0.019	6.0	LOS A	0.0	0.1	0.41	0.58	0.41	42.8
All Vehicles		623	13.9	623	13.9	0.293	0.4	NA	0.0	0.4	0.03	0.03	0.03	47.3

Site Level of Service (LOS) Method: Delay (RTA NSW). Site LOS Method is specified in the Network Data dialog (Network tab).

Vehicle movement LOS values are based on average delay per movement.

Minor Road Approach LOS values are based on average delay for all vehicle movements.

NA: Intersection LOS and Major Road Approach LOS values are Not Applicable for two-way sign control since the average delay is not a good LOS measure due to zero delays associated with major road movements.

Delay Model: SIDRA Standard (Geometric Delay is Included).

Gap-Acceptance Capacity: SIDRA Standard (Akcelik M3D).

HV (%) values are calculated for All Movement Classes of All Heavy Vehicle Model Designation.

MOVEMENT SUMMARY

Site: 101 [AM Peak Middleton Ave & Fishburn Cres (Site Folder: Existing)]

Network: N101 [AM Network (Network Folder: Existing)]

16 Carrington Rd, Castle Hill
 Site Category: (None)
 Give-Way (Two-Way)

Vehicle Movement Performance														
Mov ID	Turn	DEMAND FLOWS		ARRIVAL FLOWS		Deg. Satn	Aver. Delay	Level of Service	AVERAGE BACK OF QUEUE		Prop. Que	Effective Stop Rate	Aver. No. Cycles	Aver. Speed
		[Total veh/h]	HV %	[Total veh/h]	HV %				[Veh. veh]	[Dist m]				
South: Middleton Avenue														
8	T1	338	14.0	338	14.0	0.203	0.1	LOS A	0.1	0.6	0.05	0.02	0.05	48.3
9	R2	14	69.2	14	69.2	0.203	7.2	LOS A	0.1	0.6	0.05	0.02	0.05	43.8
Approach		352	16.2	352	16.2	0.203	0.4	NA	0.1	0.6	0.05	0.02	0.05	47.7
East: Fishburn Crescent														
10	L2	4	50.0	4	50.0	0.035	5.9	LOS A	0.0	0.4	0.43	0.67	0.43	35.3
12	R2	20	10.5	20	10.5	0.035	7.8	LOS A	0.0	0.4	0.43	0.67	0.43	35.6
Approach		24	17.4	24	17.4	0.035	7.5	LOS A	0.0	0.4	0.43	0.67	0.43	35.5
North: Middleton Avenue														
1	L2	48	63.0	48	63.0	0.136	4.7	LOS A	0.0	0.0	0.00	0.10	0.00	44.8
2	T1	192	3.3	192	3.3	0.136	0.0	LOS A	0.0	0.0	0.00	0.10	0.00	48.4
Approach		240	15.4	240	15.4	0.136	0.9	NA	0.0	0.0	0.00	0.10	0.00	47.3
All Vehicles		616	15.9	616	15.9	0.203	0.9	NA	0.1	0.6	0.05	0.08	0.05	46.4

Site Level of Service (LOS) Method: Delay (RTA NSW). Site LOS Method is specified in the Network Data dialog (Network tab).

Vehicle movement LOS values are based on average delay per movement.

Minor Road Approach LOS values are based on average delay for all vehicle movements.

NA: Intersection LOS and Major Road Approach LOS values are Not Applicable for two-way sign control since the average delay is not a good LOS measure due to zero delays associated with major road movements.

Delay Model: SIDRA Standard (Geometric Delay is Included).

Gap-Acceptance Capacity: SIDRA Standard (Aliçelik M3D).

HV (%) values are calculated for All Movement Classes of All Heavy Vehicle Model Designation.

MOVEMENT SUMMARY

Site: 101 [PM Peak Carrington Rd & Middleton Ave & Andalusian Way (Site Folder: Existing)]

Network: N101 [PM Network (Network Folder: Existing)]

16 Carrington Rd, CastleHill

Site Category: (None)

Signals - EQUISAT (Fixed-Time/SCATS) Isolated Cycle Time = 120 seconds (Site User-Given Cycle Time)

Vehicle Movement Performance														
Mov ID	Turn	DEMAND FLOWS		ARRIVAL FLOWS		Deg. Satn	Aver. Delay	Level of Service	AVERAGE BACK OF QUEUE		Prop. Que	Effective Stop Rate	Aver. No. Cycles	Aver. Speed
		[Total veh/h	HV %	[Total veh/h	HV %				[Veh. veh	Dist] m				
South: Middleton Avenue														
1	L2	127	2.5	127	2.5	0.553	29.8	LOS C	10.5	74.2	0.78	0.78	0.78	18.6
2	T1	91	1.2	91	1.2	0.553	25.2	LOS B	10.5	74.2	0.78	0.78	0.78	19.5
3	R2	187	0.6	187	0.6	+0.553	29.8	LOS C	10.5	74.2	0.78	0.78	0.78	23.4
Approach		405	1.3	405	1.3	0.553	28.8	LOS C	10.5	74.2	0.78	0.78	0.78	21.2
East: Carrington Road														
4	L2	86	0.0	86	0.0	0.347	28.0	LOS B	6.8	48.2	0.70	0.65	0.70	22.1
5	T1	467	0.9	467	0.9	0.347	24.6	LOS B	6.8	48.2	0.72	0.64	0.72	27.0
6	R2	8	0.0	8	0.0	0.347	30.0	LOS C	6.5	45.9	0.73	0.63	0.73	26.6
Approach		562	0.7	562	0.7	0.347	25.2	LOS B	6.8	48.2	0.71	0.64	0.71	26.4
North: Andalusian Way														
7	L2	22	0.0	22	0.0	0.191	29.6	LOS C	2.7	18.9	0.69	0.67	0.69	25.9
8	T1	44	0.0	44	0.0	0.191	25.0	LOS B	2.7	18.9	0.69	0.67	0.69	15.0
9	R2	48	4.3	48	4.3	0.191	29.6	LOS C	2.7	18.9	0.69	0.67	0.69	21.5
Approach		115	1.8	115	1.8	0.191	27.8	LOS B	2.7	18.9	0.69	0.67	0.69	20.5
West: Carrington Road														
10	L2	17	0.0	17	0.0	0.558	31.0	LOS C	12.5	88.5	0.80	0.71	0.80	22.1
11	T1	520	1.4	520	1.4	0.558	27.5	LOS B	12.5	88.5	0.80	0.72	0.80	25.7
12	R2	137	3.1	137	3.1	+0.558	39.9	LOS C	5.9	42.3	0.87	0.79	0.87	11.1
Approach		674	1.7	674	1.7	0.558	30.1	LOS C	12.5	88.5	0.82	0.73	0.82	23.0
All Vehicles		1756	1.3	1756	1.3	0.558	28.1	LOS B	12.5	88.5	0.77	0.71	0.77	23.5

Site Level of Service (LOS) Method: Delay (RTA NSW). Site LOS Method is specified in the Network Data dialog (Network tab).

Vehicle movement LOS values are based on average delay per movement.

Intersection and Approach LOS values are based on average delay for all vehicle movements.

Delay Model: SIDRA Standard (Geometric Delay is Included).

Gap-Acceptance Capacity: SIDRA Standard (Alqelk M3D).

HV (%) values are calculated for All Movement Classes of All Heavy Vehicle Model Designation.

+ Critical Movement (Signal Timing)

Pedestrian Movement Performance											
Mov ID	Crossing	Dem. Flow	Aver. Delay	Level of Service	AVERAGE BACK OF QUEUE		Prop. Que	Effective Stop Rate	Travel Time	Travel Dist.	Aver. Speed
					[Ped ped	Dist] m					
South: Middleton Avenue											
P1	Full	26	54.2	LOS E	0.1	0.1	0.95	0.95	215.1	209.2	0.97
East: Carrington Road											
P2	Full	1	54.2	LOS E	0.0	0.0	0.95	0.95	219.7	215.2	0.98
North: Andalusian Way											
P3	Full	31	54.2	LOS E	0.1	0.1	0.95	0.95	215.1	209.2	0.97
West: Carrington Road											

P4 Full	80	54.3	LOS E	0.3	0.3	0.95	0.95	219.9	215.2	0.98
All Pedestrians	138	54.3	LOS E	0.3	0.3	0.95	0.95	217.9	212.7	0.98

Level of Service (LOS) Method: SIDRA Pedestrian LOS Method (Based on Average Delay)

Pedestrian movement LOS values are based on average delay per pedestrian movement.

Intersection LOS value for Pedestrians is based on average delay for all pedestrian movements.

MOVEMENT SUMMARY

Site: 101 [PM Peak Middleton Ave & Patridge Ave (Site Folder: Existing)]

Network: N101 [PM Network (Network Folder: Existing)]

16 Carrington Rd, CastleHill
 Site Category: (None)
 Give-Way (Two-Way)

Vehicle Movement Performance														
Mov ID	Turn	DEMAND FLOWS		ARRIVAL FLOWS		Deg. Satn	Aver. Delay	Level of Service	AVERAGE BACK OF QUEUE		Prop. Que	Effective Stop Rate	Aver. No. Cycles	Aver. Speed
		[Total veh/h]	[HV %]	[Total veh/h]	[HV %]				[Veh.]	[Dist]				
South: Middleton Avenue														
1	L2	1	0.0	1	0.0	0.294	4.6	LOS A	0.0	0.0	0.00	0.00	0.00	49.0
2	T1	392	1.3	392	1.3	0.294	0.0	LOS A	0.0	0.0	0.00	0.00	0.00	49.7
Approach		393	1.3	393	1.3	0.294	0.0	NA	0.0	0.0	0.00	0.00	0.00	49.7
North: Middleton Avenue														
8	T1	253	1.7	253	1.7	0.137	0.1	LOS A	0.0	0.2	0.03	0.02	0.03	47.9
9	R2	9	0.0	9	0.0	0.137	6.2	LOS A	0.0	0.2	0.03	0.02	0.03	48.0
Approach		262	1.6	262	1.6	0.137	0.3	NA	0.0	0.2	0.03	0.02	0.03	47.9
West: Patridge Avenue														
10	L2	13	0.0	13	0.0	0.018	5.9	LOS A	0.0	0.1	0.41	0.58	0.41	42.8
12	R2	1	0.0	1	0.0	0.018	7.3	LOS A	0.0	0.1	0.41	0.58	0.41	42.8
Approach		14	0.0	14	0.0	0.018	6.0	LOS A	0.0	0.1	0.41	0.58	0.41	42.8
All Vehicles		668	1.4	668	1.4	0.294	0.3	NA	0.0	0.2	0.02	0.02	0.02	48.1

Site Level of Service (LOS) Method: Delay (RTA NSW). Site LOS Method is specified in the Network Data dialog (Network tab).

Vehicle movement LOS values are based on average delay per movement.

Minor Road Approach LOS values are based on average delay for all vehicle movements.

NA: Intersection LOS and Major Road Approach LOS values are Not Applicable for two-way sign control since the average delay is not a good LOS measure due to zero delays associated with major road movements.

Delay Model: SIDRA Standard (Geometric Delay is Included).

Gap-Acceptance Capacity: SIDRA Standard (Akçelik M3D).

HV (%) values are calculated for All Movement Classes of All Heavy Vehicle Model Designation.

MOVEMENT SUMMARY

Site: 101 [PM Peak Middleton Ave & Fishburn Cres (Site Folder: Existing)]

Network: N101 [PM Network (Network Folder: Existing)]

16 Carrington Rd, Castle Hill
 Site Category: (None)
 Give-Way (Two-Way)

Vehicle Movement Performance														
Mov ID	Turn	DEMAND FLOWS		ARRIVAL FLOWS		Deg. Satn	Aver. Delay	Level of Service	AVERAGE BACK OF QUEUE		Prop. Que	Effective Stop Rate	Aver. No. Cycles	Aver. Speed
		[Total veh/h]	[HV %]	[Total veh/h]	[HV %]				[Veh. veh]	[Dist m]				
South: Middleton Avenue														
8	T1	360	1.2	360	1.2	0.186	0.0	LOS A	0.0	0.1	0.01	0.01	0.01	49.4
9	R2	4	0.0	4	0.0	0.186	5.6	LOS A	0.0	0.1	0.01	0.01	0.01	47.2
Approach		364	1.2	364	1.2	0.186	0.1	NA	0.0	0.1	0.01	0.01	0.01	49.3
East: Fishburn Crescent														
10	L2	11	0.0	11	0.0	0.049	5.3	LOS A	0.1	0.5	0.41	0.65	0.41	38.5
12	R2	29	0.0	29	0.0	0.049	7.4	LOS A	0.1	0.5	0.41	0.65	0.41	36.3
Approach		40	0.0	40	0.0	0.049	6.8	LOS A	0.1	0.5	0.41	0.65	0.41	37.0
North: Middleton Avenue														
1	L2	24	0.0	24	0.0	0.130	4.6	LOS A	0.0	0.0	0.00	0.05	0.00	47.6
2	T1	228	1.8	228	1.8	0.130	0.0	LOS A	0.0	0.0	0.00	0.05	0.00	48.3
Approach		253	1.7	253	1.7	0.130	0.4	NA	0.0	0.0	0.00	0.05	0.00	48.2
All Vehicles		657	1.3	657	1.3	0.186	0.6	NA	0.1	0.5	0.03	0.06	0.03	47.1

Site Level of Service (LOS) Method: Delay (RTA NSW). Site LOS Method is specified in the Network Data dialog (Network tab).
 Vehicle movement LOS values are based on average delay per movement.
 Minor Road Approach LOS values are based on average delay for all vehicle movements.
 NA: Intersection LOS and Major Road Approach LOS values are Not Applicable for two-way sign control since the average delay is not a good LOS measure due to zero delays associated with major road movements.
 Delay Model: SIDRA Standard (Geometric Delay is Included).
 Gap-Acceptance Capacity: SIDRA Standard (Akçelik M3D).
 HV (%) values are calculated for All Movement Classes of All Heavy Vehicle Model Designation.

NETWORK LAYOUT

■ ■ Network: N101 [AM Peak (Network Folder: Proposed)]

New Network

Network Category: (None)

Layout pictures are schematic functional drawings reflecting input data. They are not design drawings.

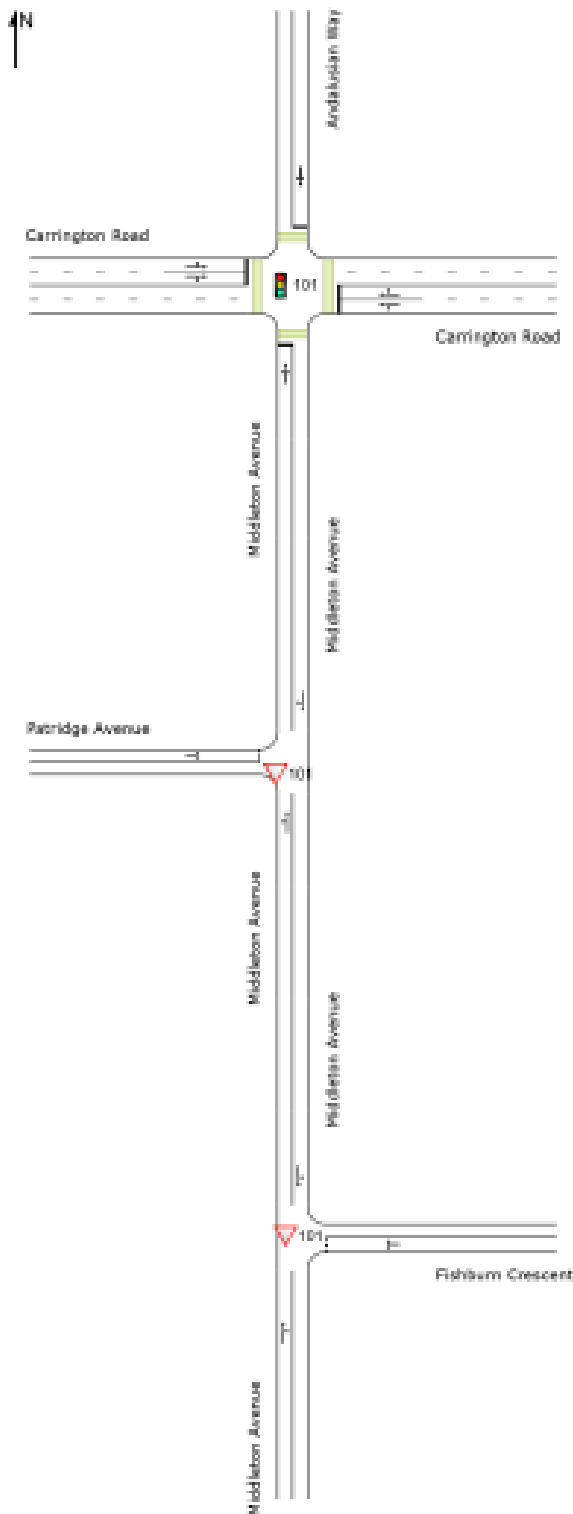

SITES IN NETWORK

Site ID	CCG ID	Site Name
■ 101	NA	AM Peak Carrington Rd & Middleton Ave & Andalusian Way
▽ 101	NA	AM Peak Middleton Ave & Partridge Ave
▽ 101	NA	AM Peak Middleton Ave & Fishburn Cres

MOVEMENT SUMMARY

Site: 101 [AM Peak Carrington Rd & Middleton Ave & Andalusian Way (Site Folder: Proposed)]

Network: N101 [AM Peak (Network Folder: Proposed)]

Output produced by SIDRA INTERSECTION Version: 9.1.6.228

18 Carrington Rd, CastleHill

Site Category: (None)

Signals - EQUISAT (Fixed-Time/SCATS) Isolated Cycle Time = 120 seconds (Site User-Given Cycle Time)

Vehicle Movement Performance															
Mov ID	Turn	Mov Class	Demand Flows [Total HV]		Arrival Flows [Total HV]		Deg. Sat'n	Aver. Delay	Level of Service	Aver. Back Of Queue Prop. Que		Eff. Stop Rate	Aver. No. of Cycles	Aver. Speed	
			veh/h	%	veh/h	%	v/c	sec		[Veh. veh	Dist] m			km/h	
South: Middleton Avenue															
1	L2	All MCs	207	7.6	207	7.6	0.625	30.7	LOS C	11.7	90.0	0.82	0.81	0.82	17.4
2	T1	All MCs	48	4.3	48	4.3	0.625	26.1	LOS B	11.7	90.0	0.82	0.81	0.82	18.8
3	R2	All MCs	193	16.4	193	16.4	*0.625	31.6	LOS C	11.7	90.0	0.82	0.81	0.82	22.2
Approach			448	11.0	448	11.0	0.625	30.6	LOS C	11.7	90.0	0.82	0.81	0.82	19.8
East: Carrington Road															
4	L2	All MCs	123	4.3	123	4.3	0.439	29.3	LOS C	9.0	64.2	0.74	0.69	0.74	21.4
5	T1	All MCs	595	1.8	595	1.8	0.439	24.6	LOS B	9.0	64.2	0.74	0.67	0.74	26.9
6	R2	All MCs	8	0.0	8	0.0	0.439	37.8	LOS C	8.9	63.1	0.74	0.65	0.74	26.5
Approach			726	2.2	726	2.2	0.439	25.5	LOS B	9.0	64.2	0.74	0.67	0.74	26.1
North: Andalusian Way															
7	L2	All MCs	13	0.0	13	0.0	0.150	26.7	LOS B	1.9	13.4	0.70	0.67	0.70	24.6
8	T1	All MCs	26	4.0	26	4.0	0.150	22.1	LOS B	1.9	13.4	0.70	0.67	0.70	14.3
9	R2	All MCs	40	2.6	40	2.6	0.150	35.6	LOS C	1.9	13.4	0.70	0.67	0.70	20.4
Approach			79	2.7	79	2.7	0.150	29.7	LOS C	1.9	13.4	0.70	0.67	0.70	19.6
West: Carrington Road															
10	L2	All MCs	15	7.1	15	7.1	0.342	28.0	LOS B	6.7	48.2	0.70	0.61	0.70	22.7
11	T1	All MCs	274	2.7	274	2.7	0.342	23.4	LOS B	6.7	48.2	0.70	0.61	0.70	27.8
12	R2	All MCs	126	24.2	126	24.2	*0.615	45.3	LOS D	4.1	34.6	0.91	0.83	0.93	9.8
Approach			415	9.4	415	9.4	0.615	30.3	LOS C	6.7	48.2	0.76	0.68	0.77	21.9
All Vehicles			1668	6.4	1668	6.4	0.625	28.3	LOS B	11.7	90.0	0.76	0.71	0.77	23.1

Site Level of Service (LOS) Method: Delay (RTA NSW). Site LOS Method is specified in the Network Data dialog (Override Site Data tab).

Vehicle movement LOS values are based on average delay per movement.

Intersection and Approach LOS values are based on average delay for all vehicle movements.

Delay Model: SIDRA Standard (Control Delay; Geometric Delay is Included).

Queue Model: SIDRA queue estimation methods are used for Back of Queue and Queue at Start of Green.

Gap-Acceptance Capacity Formula: SIDRA Standard (Akpelik M3D).

HV (%) values are calculated for All Movement Classes of All Heavy Vehicle Model Designation.

Arrival Flows used in performance calculations are adjusted to include any Initial Queued Demand and Upstream Capacity Constraint effects.

* Critical Movement (Signal Timing)

Pedestrian Movement Performance											
Mov ID	Crossing	Dem. Flow	Aver. Delay	Level of Service	AVERAGE BACK OF QUEUE		Prop. Que	Eff. Stop Rate	Travel Time	Travel Dist.	Aver. Speed
		ped/h	sec		[Ped ped	Dist] m			sec	m	m/sec
South: Middleton Avenue											
P1	Full	26	54.2	LOS E	0.1	0.1	0.95	0.95	208.1	200.0	0.96
East: Carrington Road											

P2	Full	1	54.2	LOS E	0.0	0.0	0.95	0.95	208.0	200.0	0.96
North: Andalusian Way											
P3	Full	31	54.2	LOS E	0.1	0.1	0.95	0.95	208.1	200.0	0.96
West: Carrington Road											
P4	Full	80	54.3	LOS E	0.3	0.3	0.95	0.95	208.2	200.0	0.96
All Pedestrians		138	54.3	LOS E	0.3	0.3	0.95	0.95	208.1	200.0	0.96

Level of Service (LOS) Method: SIDRA Pedestrian LOS Method (Based on Average Delay)
 Pedestrian movement LOS values are based on average delay per pedestrian movement.
 Intersection LOS value for Pedestrians is based on average delay for all pedestrian movements.

MOVEMENT SUMMARY

Site: 101 [AM Peak Middleton Ave & Patridge Ave (Site Folder: Proposed)]

Network: N101 [AM Peak (Network Folder: Proposed)]

Output produced by SIDRA INTERSECTION Version: 9.1.6.228

16 Carrington Rd, Castle Hill
Site Category: (None)
Give-Way (Two-Way)

Vehicle Movement Performance															
Mov ID	Turn	Mov Class	Demand Flows		Arrival Flows		Deg. Satn	Aver. Delay	Level of Service	Aver. Back Of Queue		Prop. Que	Eff. Stop Rate	Aver. No. of Cycles	Aver. Speed
			[Total HV]	%	[Total HV]	%	v/c	sec		[Veh.]	[Dist]				km/h
			veh/h		veh/h					veh	m				
South: Middleton Avenue															
1	L2	All MCs	4	0.0	4	0.0	0.237	4.6	LOS A	0.4	3.1	0.00	0.01	0.00	47.7
2	T1	All MCs	434	11.4	434	11.4	0.237	0.0	LOS A	0.4	3.1	0.00	0.01	0.00	49.5
Approach			438	11.3	438	11.3	0.237	0.1	NA	0.4	3.1	0.00	0.01	0.00	49.4
North: Middleton Avenue															
8	T1	All MCs	257	14.3	257	14.3	0.155	0.2	LOS A	0.1	0.4	0.06	0.08	0.06	46.2
9	R2	All MCs	16	0.0	16	0.0	0.155	6.5	LOS A	0.1	0.4	0.06	0.08	0.06	47.0
Approach			273	13.5	273	13.5	0.155	0.5	NA	0.1	0.4	0.06	0.08	0.06	46.4
West: Patridge Avenue															
10	L2	All MCs	12	0.0	12	0.0	0.027	6.2	LOS A	0.0	0.1	0.46	0.62	0.46	42.6
12	R2	All MCs	2	0.0	2	0.0	0.027	8.0	LOS A	0.0	0.1	0.46	0.62	0.46	42.6
Approach			14	0.0	14	0.0	0.027	6.5	LOS A	0.0	0.1	0.46	0.62	0.46	42.6
All Vehicles			724	11.9	724	11.9	0.237	0.4	NA	0.4	3.1	0.03	0.04	0.03	47.4

Site Level of Service (LOS) Method: Delay (RTA NSW). Site LOS Method is specified in the Network Data dialog (Override Site Data tab).

Vehicle movement LOS values are based on average delay per movement.

Minor Road Approach LOS values are based on average delay for all vehicle movements.

NA (TWSC): Level of Service is not defined for major road approaches or the intersection as a whole for Two-Way Sign Control (HCM LOS rule).

Two-Way Sign Control Capacity Model: SIDRA Standard.

Delay Model: SIDRA Standard (Control Delay: Geometric Delay is Included).

Queue Model: SIDRA queue estimation methods are used for Back of Queue and Queue at Start of Gap.

Gap-Acceptance Capacity Formula: SIDRA Standard (Akpelik M3D).

HV (%) values are calculated for All Movement Classes of All Heavy Vehicle Model Designation.

Arrival Flows used in performance calculations are adjusted to include any Initial Queued Demand and Upstream Capacity Constraint effects.

MOVEMENT SUMMARY

Site: 101 [AM Peak Middleton Ave & Fishburn Cres (Site

Folder: Proposed)]

Network: N101 [AM Peak
(Network Folder: Proposed)]

Output produced by SIDRA INTERSECTION Version: 9.1.6.228

16 Carrington Rd, CastleHill

Site Category: (None)

Give-Way (Two-Way)

Vehicle Movement Performance															
Mov ID	Turn	Mov Class	Demand Flows		Arrival Flows		Deg. Satn	Aver. Delay	Level of Service	Aver. Back Of Queue Prop.		Eff. Stop Rate	Aver. No. of Cycles	Aver. Speed	
			[Total HV]	[Total HV]	[Total HV]	[Total HV]	v/c	sec		[Veh. veh	[Dist] m			km/h	
South: Middleton Avenue															
8	T1	All MCs	338	14.0	338	14.0	0.208	0.2	LOS A	0.1	0.7	0.07	0.07	0.07	47.4
9	R2	All MCs	19	50.0	19	50.0	0.208	6.9	LOS A	0.1	0.7	0.07	0.07	0.07	43.2
Approach			357	15.9	357	15.9	0.208	0.5	NA	0.1	0.7	0.07	0.07	0.07	46.7
East: Fishburn Crescent															
10	L2	All MCs	24	8.7	24	8.7	0.166	5.4	LOS A	0.2	1.7	0.48	0.70	0.48	36.1
12	R2	All MCs	101	2.1	101	2.1	0.166	8.0	LOS A	0.2	1.7	0.48	0.70	0.48	35.4
Approach			125	3.4	125	3.4	0.166	7.5	LOS A	0.2	1.7	0.48	0.70	0.48	35.6
North: Middleton Avenue															
1	L2	All MCs	68	44.6	68	44.6	0.147	4.6	LOS A	0.0	0.0	0.00	0.14	0.00	43.0
2	T1	All MCs	192	3.3	192	3.3	0.147	0.0	LOS A	0.0	0.0	0.00	0.14	0.00	47.1
Approach			260	14.2	260	14.2	0.147	1.2	NA	0.0	0.0	0.00	0.14	0.00	45.5
All Vehicles			742	13.2	742	13.2	0.208	1.9	NA	0.2	1.7	0.11	0.20	0.11	42.8

Site Level of Service (LOS) Method: Delay (RTA NSW). Site LOS Method is specified in the Network Data dialog (Override Site Data tab).

Vehicle movement LOS values are based on average delay per movement.

Minor Road Approach LOS values are based on average delay for all vehicle movements.

NA (TWSC): Level of Service is not defined for major road approaches or the intersection as a whole for Two-Way Sign Control (HCM LOS rule).

Two-Way Sign Control Capacity Model: SIDRA Standard.

Delay Model: SIDRA Standard (Control Delay: Geometric Delay is Included).

Queue Model: SIDRA queue estimation methods are used for Back of Queue and Queue at Start of Gap.

Gap-Acceptance Capacity Formula: SIDRA Standard (Akçelik M3D).

HV (%) values are calculated for All Movement Classes of All Heavy Vehicle Model Designation.

Arrival Flows used in performance calculations are adjusted to include any Initial Queued Demand and Upstream Capacity Constraint effects.

MOVEMENT SUMMARY

Site: 101 [PM Peak Carrington Rd & Middleton Ave & Andalusian Way (Site Folder: Proposed)]

Network: N101 [PM Peak (Network Folder: Proposed)]

Output produced by SIDRA INTERSECTION Version: 9.1.6.228

16 Carrington Rd, CastleHill

Site Category: (None)

Signals - EQUISAT (Fixed-Time/SCATS) Isolated Cycle Time = 120 seconds (Site User-Given Cycle Time)

Vehicle Movement Performance															
Mov ID	Turn	Mov Class	Demand Flows		Arrival Flows		Deg. Satn	Aver. Delay	Level of Service	Aver. Back Of Queue		Prop. Que	Eff. Stop Rate	Aver. No. of Cycles	Aver. Speed
			[Total HV]	%	[Total HV]	%	v/c	sec		[Veh. veh	Dist]				km/h
			veh/h		veh/h					veh	m				
South: Middleton Avenue															
1	L2	All MCs	138	2.3	138	2.3	0.611	31.9	LOS C	11.7	82.9	0.83	0.81	0.83	17.2
2	T1	All MCs	91	1.2	91	1.2	0.611	27.4	LOS B	11.7	82.9	0.83	0.81	0.83	18.3
3	R2	All MCs	197	0.5	197	0.5	+0.611	33.6	LOS C	11.7	82.9	0.83	0.81	0.83	21.9
Approach			425	1.2	425	1.2	0.611	31.7	LOS C	11.7	82.9	0.83	0.81	0.83	19.8
East: Carrington Road															
4	L2	All MCs	126	0.0	126	0.0	0.354	26.3	LOS B	7.1	50.0	0.68	0.66	0.68	22.7
5	T1	All MCs	467	0.9	467	0.9	0.354	22.8	LOS B	7.1	50.0	0.70	0.63	0.70	27.6
6	R2	All MCs	8	0.0	8	0.0	0.354	49.2	LOS D	6.8	48.1	0.71	0.62	0.71	26.8
Approach			602	0.7	602	0.7	0.354	23.9	LOS B	7.1	50.0	0.70	0.64	0.70	26.7
North: Andalusian Way															
7	L2	All MCs	22	0.0	22	0.0	0.210	28.9	LOS C	2.8	20.0	0.72	0.68	0.72	24.2
8	T1	All MCs	44	0.0	44	0.0	0.210	24.4	LOS B	2.8	20.0	0.72	0.68	0.72	13.9
9	R2	All MCs	48	4.3	48	4.3	0.210	37.5	LOS C	2.8	20.0	0.72	0.68	0.72	20.0
Approach			115	1.8	115	1.8	0.210	30.8	LOS C	2.8	20.0	0.72	0.68	0.72	19.1
West: Carrington Road															
10	L2	All MCs	17	0.0	17	0.0	0.596	29.7	LOS C	14.1	99.7	0.80	0.71	0.80	22.2
11	T1	All MCs	520	1.4	520	1.4	0.596	25.2	LOS B	14.1	99.7	0.80	0.71	0.80	26.9
12	R2	All MCs	178	2.4	178	2.4	+0.606	41.0	LOS C	5.5	39.0	0.88	0.82	0.88	10.6
Approach			715	1.6	715	1.6	0.606	29.2	LOS C	14.1	99.7	0.82	0.74	0.82	22.9
All Vehicles			1857	1.2	1857	1.2	0.611	28.2	LOS B	14.1	99.7	0.78	0.72	0.78	23.1

Site Level of Service (LOS) Method: Delay (RTA NSW). Site LOS Method is specified in the Network Data dialog (Override Site Data tab).

Vehicle movement LOS values are based on average delay per movement.

Intersection and Approach LOS values are based on average delay for all vehicle movements.

Delay Model: SIDRA Standard (Control Delay; Geometric Delay is Included).

Queue Model: SIDRA queue estimation methods are used for Back of Queue and Queue at Start of Green.

Gap-Acceptance Capacity Formula: SIDRA Standard (Akçelik M3D).

HV (%) values are calculated for All Movement Classes of All Heavy Vehicle Model Designation.

Arrival Flows used in performance calculations are adjusted to include any Initial Queued Demand and Upstream Capacity Constraint effects.

+ Critical Movement (Signal Timing)

Pedestrian Movement Performance											
Mov ID	Crossing	Dem. Flow	Aver. Delay	Level of Service	AVERAGE BACK OF QUEUE		Prop. Que	Eff. Stop Rate	Travel Time	Travel Dist.	Aver. Speed
		ped/h	sec		[Ped ped	Dist]			sec	m	m/sec
					ped	m					
South: Middleton Avenue											
P1	Full	26	54.2	LOS E	0.1	0.1	0.95	0.95	208.1	200.0	0.96
East: Carrington Road											

P2	Full	1	54.2	LOS E	0.0	0.0	0.95	0.95	208.0	200.0	0.96
North: Andalusian Way											
P3	Full	31	54.2	LOS E	0.1	0.1	0.95	0.95	208.1	200.0	0.96
West: Carrington Road											
P4	Full	80	54.3	LOS E	0.3	0.3	0.95	0.95	208.2	200.0	0.96
All Pedestrians		138	54.3	LOS E	0.3	0.3	0.95	0.95	208.1	200.0	0.96

Level of Service (LOS) Method: SIDRA Pedestrian LOS Method (Based on Average Delay)

Pedestrian movement LOS values are based on average delay per pedestrian movement.

Intersection LOS value for Pedestrians is based on average delay for all pedestrian movements.

MOVEMENT SUMMARY

Site: 101 [PM Peak Middleton Ave & Patridge Ave (Site Folder: Proposed)]

Network: N101 [PM Peak (Network Folder: Proposed)]

Output produced by SIDRA INTERSECTION Version: 9.1.6.228

16 Carrington Rd, CastleHill
 Site Category: (None)
 Give-Way (Two-Way)

Vehicle Movement Performance															
Mov ID	Turn	Mov Class	Demand Flows [Total HV] veh/h %		Arrival Flows [Total HV] veh/h %		Deg. Satn w/c	Aver. Delay sec	Level of Service	Aver. Back of Queue [Veh. veh	Of Queue Dist] m	Prop. Que	Eff. Stop Rate	Aver. No. of Cycles	Aver. Speed km/h
South: Middleton Avenue															
1	L2	All MCs	1	0.0	1	0.0	0.364	4.6	LOS A	0.0	0.0	0.00	0.00	0.00	47.6
2	T1	All MCs	412	1.3	412	1.3	0.364	0.0	LOS A	0.0	0.0	0.00	0.00	0.00	49.6
Approach			413	1.3	413	1.3	0.364	0.0	NA	0.0	0.0	0.00	0.00	0.00	49.5
North: Middleton Avenue															
8	T1	All MCs	334	1.3	334	1.3	0.178	0.1	LOS A	0.0	0.2	0.03	0.04	0.03	48.3
9	R2	All MCs	9	0.0	9	0.0	0.178	6.3	LOS A	0.0	0.2	0.03	0.04	0.03	47.3
Approach			343	1.2	343	1.2	0.178	0.2	NA	0.0	0.2	0.03	0.04	0.03	48.2
West: Patridge Avenue															
10	L2	All MCs	13	0.0	13	0.0	0.022	6.0	LOS A	0.0	0.1	0.43	0.59	0.43	42.7
12	R2	All MCs	1	0.0	1	0.0	0.022	8.0	LOS A	0.0	0.1	0.43	0.59	0.43	42.7
Approach			14	0.0	14	0.0	0.022	6.1	LOS A	0.0	0.1	0.43	0.59	0.43	42.7
All Vehicles			769	1.2	769	1.2	0.364	0.2	NA	0.0	0.2	0.02	0.03	0.02	48.2

Site Level of Service (LOS) Method: Delay (RTA NSW). Site LOS Method is specified in the Network Data dialog (Override Site Data tab).

Vehicle movement LOS values are based on average delay per movement.

Minor Road Approach LOS values are based on average delay for all vehicle movements.

NA (TWSC): Level of Service is not defined for major road approaches or the Intersection as a whole for Two-Way Sign Control (HCM LOS rule).

Two-Way Sign Control Capacity Model: SIDRA Standard.

Delay Model: SIDRA Standard (Control Delay: Geometric Delay is Included).

Queue Model: SIDRA queue estimation methods are used for Back of Queue and Queue at Start of Gap.

Gap-Acceptance Capacity Formula: SIDRA Standard (Akcelik M3D).

HV (%) values are calculated for All Movement Classes of All Heavy Vehicle Model Designation.

Arrival Flows used in performance calculations are adjusted to include any Initial Queued Demand and Upstream Capacity Constraint effects.

MOVEMENT SUMMARY

Site: 101 [PM Peak Middleton Ave & Fishburn Cres (Site Folder: Proposed)]

Network: N101 [PM Peak (Network Folder: Proposed)]

Output produced by SIDRA INTERSECTION Version: 9.1.6.228

18 Carrington Rd, CastleHill
Site Category: (None)
Give-Way (Two-Way)

Vehicle Movement Performance															
Mov ID	Turn	Mov Class	Demand Flows [Total HV]		Arrival Flows [Total HV]		Deg. Satn	Aver. Delay	Level of Service	Aver. Back Of Queue [Veh. veh	Dist] m	Prop. Que	Eff. Stop Rate	Aver. No. of Cycles	Aver. Speed km/h
			veh/h	%	veh/h	%	v/c	sec							
South: Middleton Avenue															
8	T1	All MCs	360	1.2	360	1.2	0.202	0.1	LOS A	0.1	0.6	0.07	0.08	0.07	46.5
9	R2	All MCs	24	0.0	24	0.0	0.202	5.9	LOS A	0.1	0.6	0.07	0.08	0.07	45.1
Approach			384	1.1	384	1.1	0.202	0.5	NA	0.1	0.6	0.07	0.08	0.07	46.3
East: Fishburn Crescent															
10	L2	All MCs	16	0.0	16	0.0	0.086	5.3	LOS A	0.1	0.8	0.47	0.68	0.47	36.7
12	R2	All MCs	49	0.0	49	0.0	0.086	7.9	LOS A	0.1	0.8	0.47	0.68	0.47	35.7
Approach			65	0.0	65	0.0	0.086	7.3	LOS A	0.1	0.8	0.47	0.68	0.47	36.0
North: Middleton Avenue															
1	L2	All MCs	105	0.0	105	0.0	0.173	4.6	LOS A	0.0	0.0	0.00	0.17	0.00	43.7
2	T1	All MCs	228	1.8	228	1.8	0.173	0.0	LOS A	0.0	0.0	0.00	0.17	0.00	44.9
Approach			334	1.3	334	1.3	0.173	1.4	NA	0.0	0.0	0.00	0.17	0.00	44.4
All Vehicles			783	1.1	783	1.1	0.202	1.5	NA	0.1	0.8	0.07	0.17	0.07	43.7

Site Level of Service (LOS) Method: Delay (RTA NSW). Site LOS Method is specified in the Network Data dialog (Override Site Data tab).

Vehicle movement LOS values are based on average delay per movement.

Minor Road Approach LOS values are based on average delay for all vehicle movements.

NA (TWSC): Level of Service is not defined for major road approaches or the intersection as a whole for Two-Way Sign Control (HCM LOS rule).

Two-Way Sign Control Capacity Model: SIDRA Standard.

Delay Model: SIDRA Standard (Control Delay: Geometric Delay is Included).

Queue Model: SIDRA queue estimation methods are used for Back of Queue and Queue at Start of Gap.

Gap-Acceptance Capacity Formula: SIDRA Standard (Akçelik M3D).

HV (%) values are calculated for All Movement Classes of All Heavy Vehicle Model Designation.

Arrival Flows used in performance calculations are adjusted to include any Initial Queued Demand and Upstream Capacity Constraint effects.

APPENDIX C

SWEPT TURNING PATH DIAGRAMS

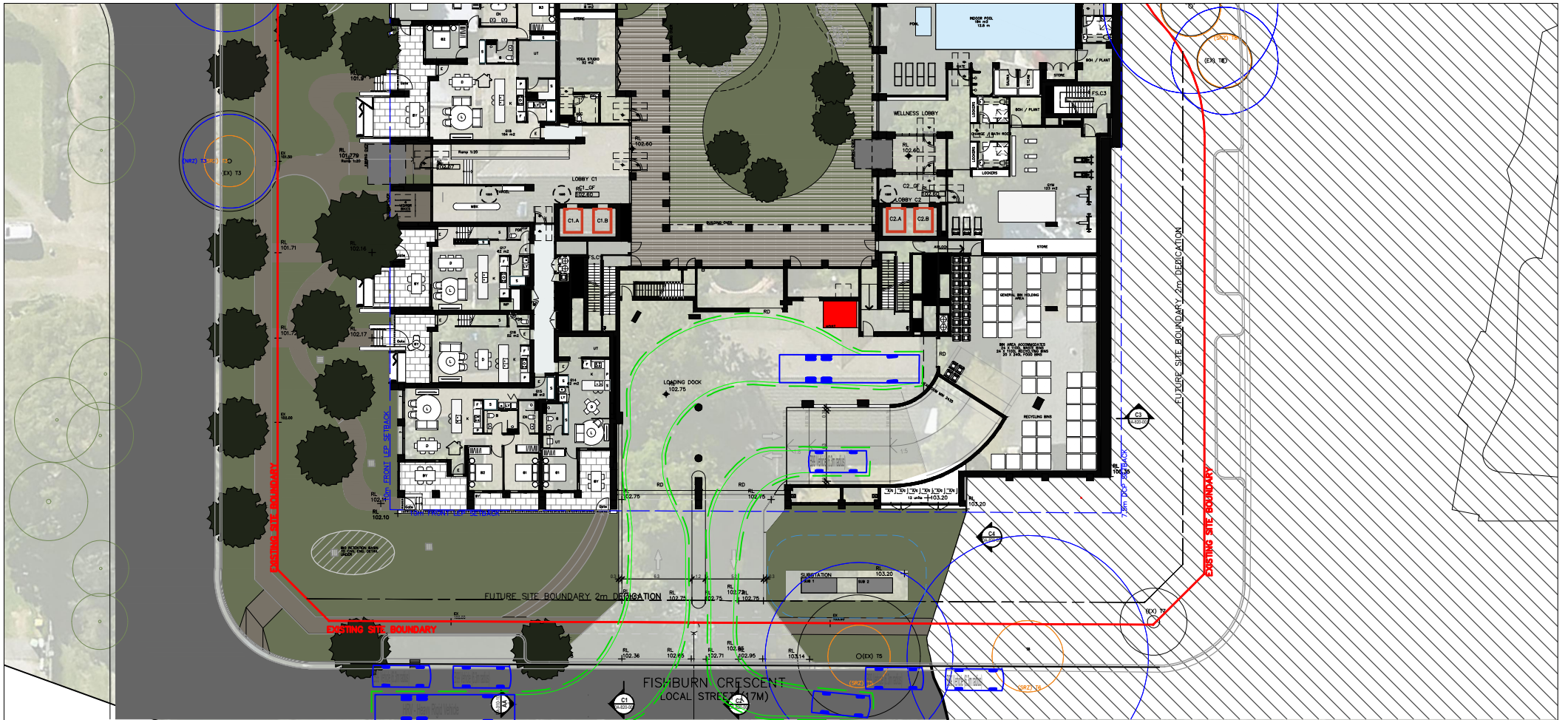

VARGA TRAFFIC PLANNING Pty Ltd
 AS/NZS 88 071 782 537
 Suite 6, Level 1
 23 Young Street
 Neutral Bay, NSW 2089

Phone +61 2 9904 3224
 PO Box 1869
 Neutral Bay, NSW 2089
 www.vargatrafic.com.au
 Sydney, Australia

PROJECT
RESIDENTIAL DEVELOPMENT



DRAWING TITLE
GF_HRV_Entry

ADDRESS
 16 Carrington Rd,
 Castle Hill

PROJECT NO.
23513

REVIEWED
 RV

1:500 @ A4

DATE DRAWN
 2025-9-3

PREPARED
 MN

VARGA TRAFFIC PLANNING Pty Ltd

Transport, Traffic and Parking Consultants

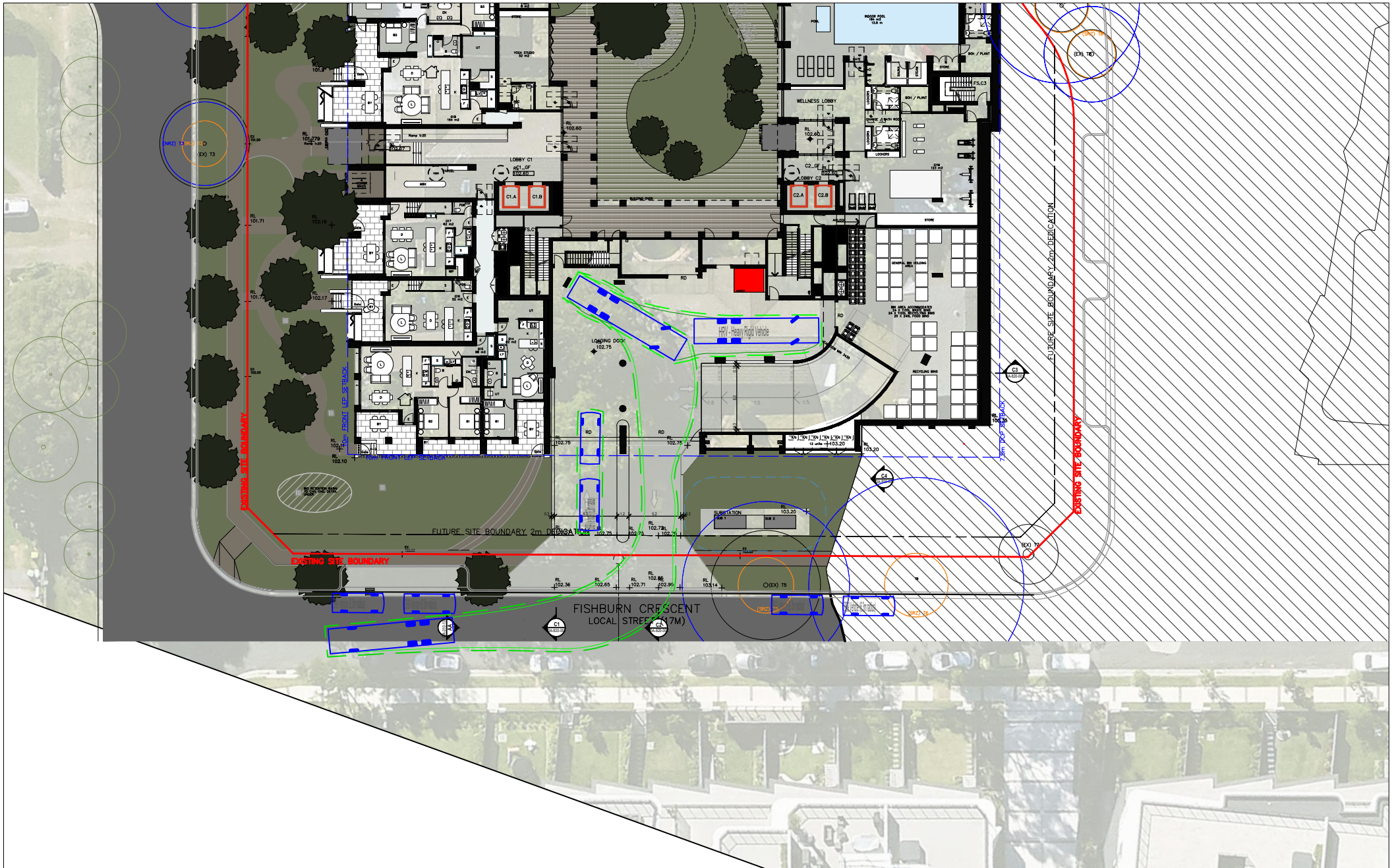

VARGA TRAFFIC PLANNING Pty Ltd
 AS/NZS 88 071 762 537
 Suite 6, Level 1
 23 Young Street
 Neutral Bay, NSW 2089

Phone +61 2 9904 3224
 PO Box 1869
 Neutral Bay, NSW 2089
 www.vargatraffic.com.au
 Sydney, Australia

PROJECT
 RESIDENTIAL DEVELOPMENT



DRAWING TITLE
 GF_HRV_Exit

ADDRESS
 16 Carrington Rd,
 Castle Hill

PROJECT NO.
 23513
 REVIEWED
 RV

1:500 @ A4

DATE DRAWN
 2025-9-3
 PREPARED
 MN

VARGA TRAFFIC PLANNING Pty Ltd
 Transport, Traffic and Parking Consultants



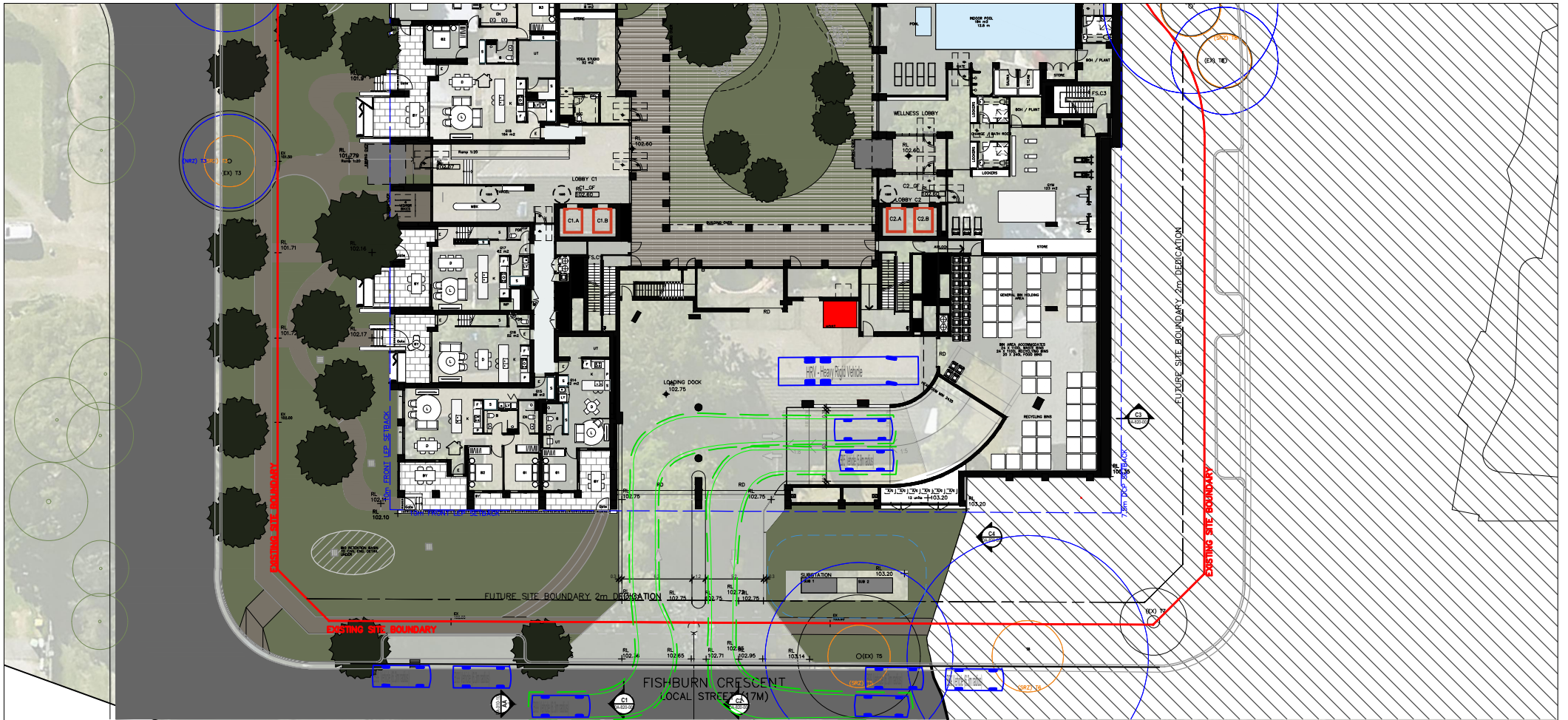

VARGA TRAFFIC PLANNING Pty Ltd Phone +61 2 9904 3224
 ASN 88 071 762 537 PO Box 1869
 Suite 6, Level 1 Neutral Bay, NSW 2089
 29 Young Street www.vargatraffic.com.au
 Neutral Bay, NSW 2089 Sydney, Australia

PROJECT
RESIDENTIAL DEVELOPMENT



DRAWING TITLE
GF_B99&B85_Passing

ADDRESS
**16 Carrington Rd,
 Castle Hill**

PROJECT NO.
23513

REVIEWED
RV

SCALE
1:500 @ A4

DATE DRAWN
2025-9-3

PREPARED
MN

VARGA TRAFFIC PLANNING Pty Ltd
Transport, Traffic and Parking Consultants

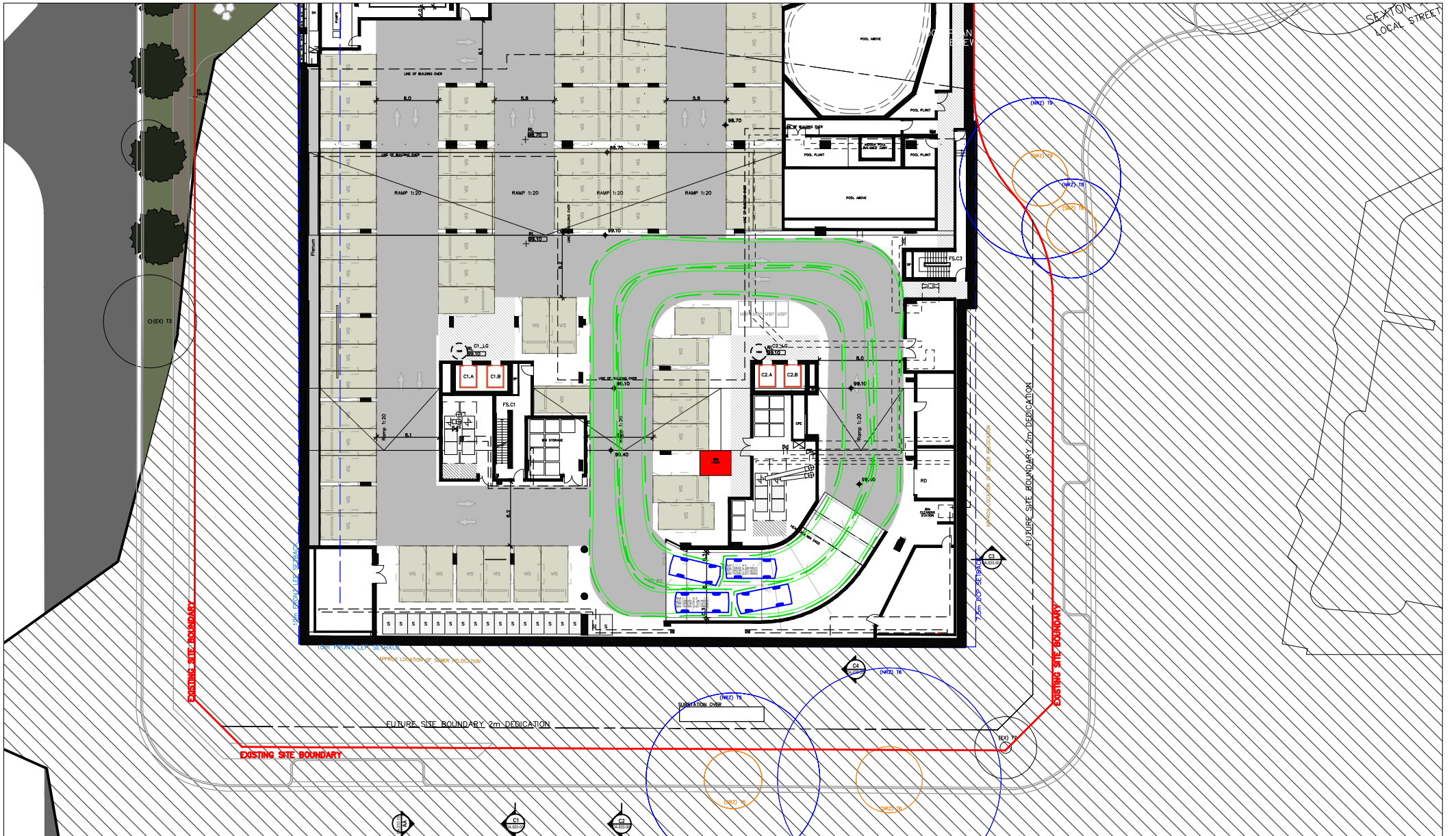

VARGA TRAFFIC PLANNING Pty Ltd
 AS/NZS 88 071 762 537
 Suite 6, Level 1
 23 Young Street
 Neutral Bay, NSW 2089
 www.vargatp.com.au
 Sydney, Australia

Phone +61 2 9904 3224
 PO Box 1868
 Neutral Bay, NSW 2089
 www.vargatp.com.au
 Sydney, Australia

PROJECT
RESIDENTIAL DEVELOPMENT



DRAWING TITLE
LowerGF_B99&B85_Passing

ADDRESS
 16 Carrington Rd,
 Castle Hill

1:500 @ A4

PROJECT NO
23513

REVIEWED
 RV

DATE DRAWN
 2025-9-3

PREPARED
 MN

VARGA TRAFFIC PLANNING Pty Ltd

Transport, Traffic and Parking Consultants

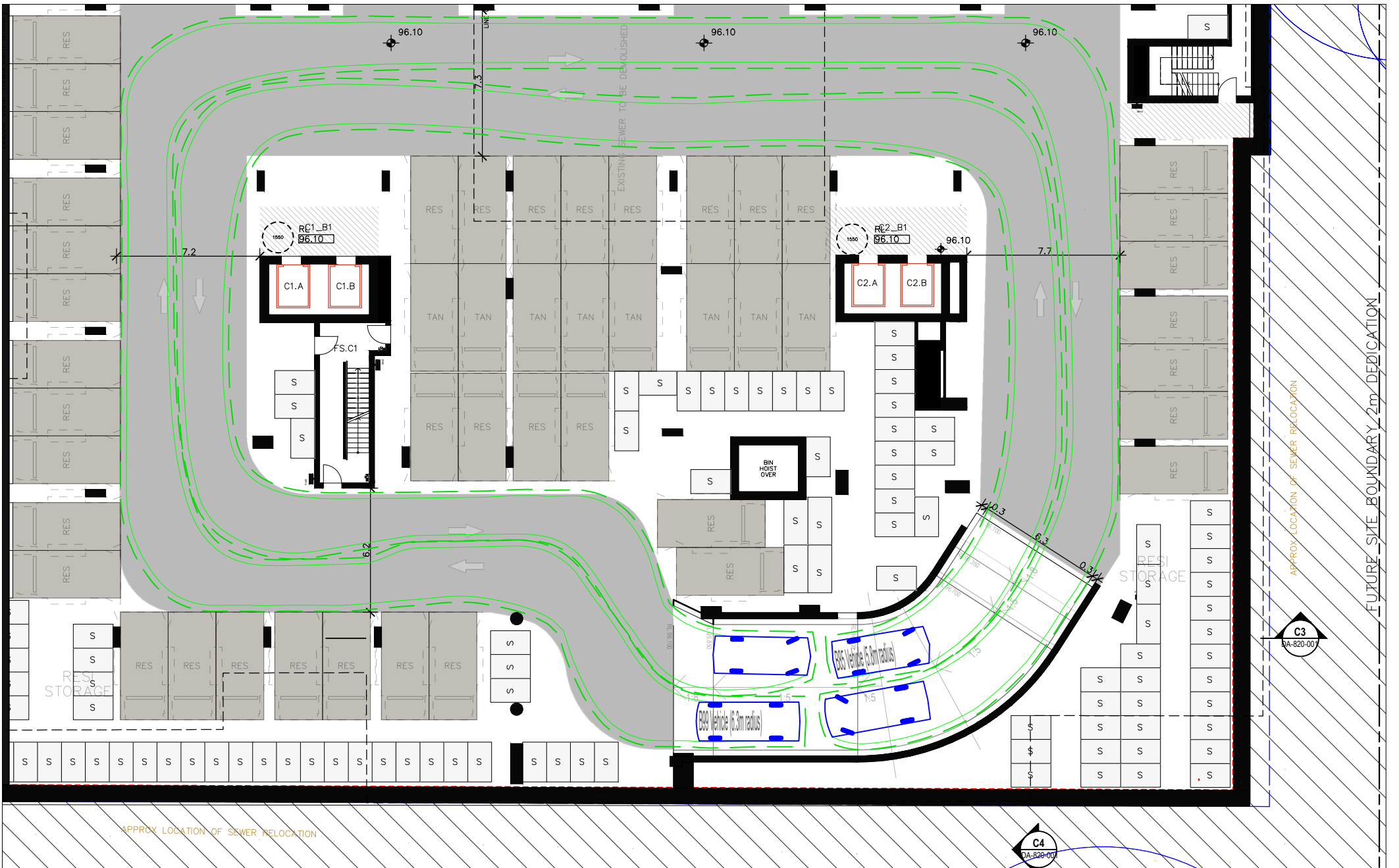

APPROX LOCATION OF SEWER RELOCATION

APPROX LOCATION OF SEWER RELOCATION

FUTURE SITE BOUNDARY 2m DEDICATION

VARGA TRAFFIC PLANNING Pty Ltd
 AS/NZS 88:071 782 537
 Suite 6, Level 1
 29 Young Street
 Neutral Bay, NSW 2089

Phone +61 2 9904 3224
 PO Box 1868
 Neutral Bay, NSW 2089
 www.vargatrafic.com.au
 Sydney, Australia

PROJECT
 RESIDENTIAL DEVELOPMENT



DRAWING TITLE
 Basement01_B99&B85_Passing

ADDRESS
 16 Carrington Rd,
 Castle Hill

PROJECT NO.
 23513
 REVIEWED
 RV

1:250 @ A4

DATE DRAWN
 2025-9-3
 PREPARED
 MN

VARGA TRAFFIC PLANNING Pty Ltd
 Transport, Traffic and Parking Consultants



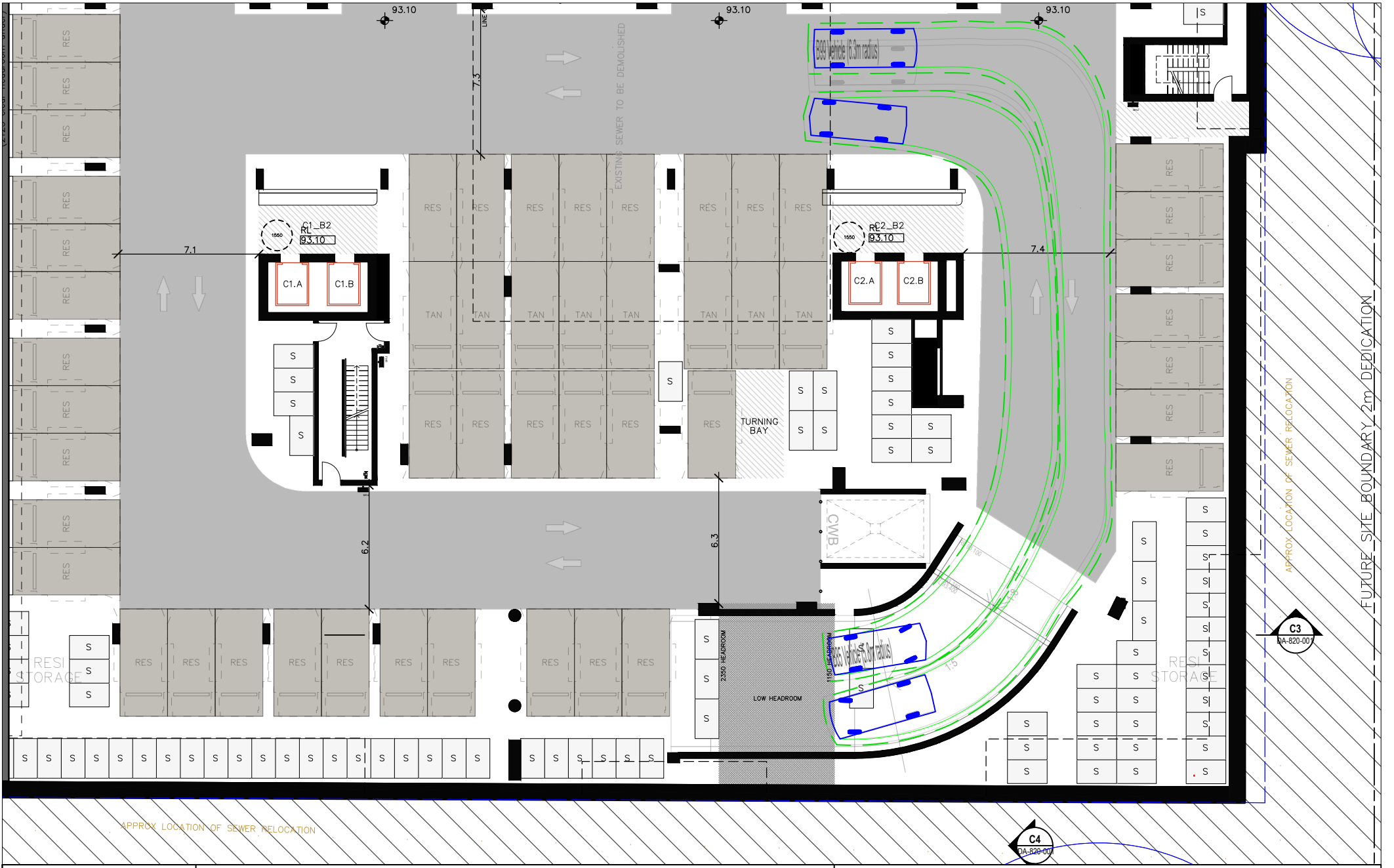

VARGA TRAFFIC PLANNING Pty Ltd
 ASN 88 071 782 537
 Suite 6, Level 1
 20 Young Street
 Neutral Bay, NSW 2089

Phone +61 2 9904 3224
 PO Box 1888
 Neutral Bay, NSW 2089
 www.vargatrafic.com.au
 Sydney, Australia

PROJECT
RESIDENTIAL DEVELOPMENT



DRAWING TITLE
Basement02_B99&B85_Passing

ADDRESS
 16 Carrington Rd,
 Castle Hill

PROJECT NO.
 23513

REVIEWED
 RV

1:250 @ A4

DATE DRAWN
 2025-9-3

PREPARED
 MN

VARGA TRAFFIC PLANNING Pty Ltd

Transport, Traffic and Parking Consultants