

ACCESS LINK CONSULTING

Solutions to last a lifetime

ACCESSIBILITY COMPLIANCE REPORT

For SSDA Application

Project Address: 2 Fishburn Crescent, Castle Hill NSW

Prepared For: ARADA Development Management Pty Ltd

Issue No: C

Issue Date: 15/09/2025

Report No: SSDA-24010

Report Register:

The following report register documents the development and issue of this report as undertaken by Access Link Consulting Pty Ltd

Report No.	Issue No.	Issue Date	Report Details
SSDA-24010	A	24/08/2025	DRAFT Issue
SSDA-24010	B	13/09/2025	Issue for SSDA
SSDA-24010	C	15/09/2025	Issue for SSDA

1.0 - Report Purpose:

This report has been prepared to accompany a State Significant Development Application (SSDA) for the site located at **2 Fishburn Crescent, Castle Hill Castle Hill NSW**. The site is made up of multiple lots. The legal description is outlined in Table 1.

Table 1 - Legal Description of the Site

Property Address	Title Description
2 Fishburn Crescent, Castle Hill	Lot 1 DP 253774, 16 Carrington Road; Lot 27 DP 247890, 18 Carrington Road; Lot 26 DP 247890, 20 Carrington Road; Lot 2 DP 1257535, 2 Middleton Avenue; Lot 24 DP 247890, 4 Middleton Avenue; Lot 23 DP 247890, 6 Middleton Avenue; Lot 22 DP247890, 8 Middleton Avenue; Lot 21 DP 247890, 10 Middleton Avenue; Lot 20 DP 247890, 12 Middleton Avenue; Lot 32 DP 247890, 4 Fishburn Crescent; Lot 31 DP 247890, 6 Fishburn Crescent; Lot 30 DP 247890, 31 Sexton Avenue; Lot 29 DP 247890, 29 Sexton Avenue; Lot 28 DP247890, 27 Sexton Avenue; Lot 2 DP253774, 25 Sexton Avenue within The Hills Shire.

This report has been prepared to address the Secretary's Environmental Assessment Requirements (SEARs) issued on 30 April 2025 for the project (SSD-83112728).

This report concludes that the proposed development is suitable and warrants approval, subject to the implementation of the following mitigation measures:

- Accessibility requirements under the premises standards and the relevant section of the NCC 2022 Amd 2, 2022

Following the implementation of the above mitigation measures, the remaining impacts are appropriate.

This report has been prepared in response to the requirements contained within the Secretary's Environmental Assessment Requirements (SEARs) dated 30 April 2025 and issued for the SSDA (SSD-83112728).

The subject project achieves the spatial requirements to provide access for people with disability under the relevant standards and codes, it is required that a detailed assessment to be undertaken, covering but not limited of internal fit-out, details for stairs, ramps, finishes, amenities and other features to occur at CC "Construction Certificate" stage.

By adopting the recommendation set in this report, compliance with the report basis will be achieved and equitable and dignified access for all users of the building/facility will be provided.

2.0 – Site Description and Use:

The proposed development, the subject of this SSD application, is for the following works:

- Earthworks and tree removal
- Construction of a new residential flat development with a total of 431 apartments above three basement parking levels, comprising the following buildings:
 - Building A at the north-western corner, which is 20 storeys and contains 135 apartments
 - Building B at the north-eastern corner, which is part 8, part 17 storeys and contains 135 apartments
 - Building C, which is a U-shaped building at the southern end of the site, is part 11 part 12 storeys and contains 161 apartments
- Landscaping, civil and stormwater works
- Augmentation of, and connection to, existing utilities as required

3.0 – Project Classification:

This accessibility compliance report for a proposed building with classification as set below:

- Class 2
- Class 7a

Note: The classification/s above are our understanding of the relevant BCA classification/s. BCA consultant/certifier must confirm and determine the BCA classifications.

4.0 – Report Basis:

This report is based in the context of:

- National Construction Code 2022 Amd. 2, Volume One – Building Code of Australia (BCA).
 - D1P1, D1P2, D1P8, D1P9
 - E3P4
 - F4P1
 - Parts of D1, D4, E3 and F4
- AS 1428.1 – 2021
- AS 1428.4.1 – 2009
- AS 2890.6 – 2009
- AS 1735.12 – 1999
- Disability (Access to Premises-Building) Amended Standards 2010
- Australian Human Rights Commission’s Guidelines on application of APS version 2.
- Livable Housing Australia’s Livable Housing Design Guidelines – Fourth Edition

5.0 – Assessed Drawings:

Drawing No.	Drawing Title	Issue	Issue Date
DA-110-005	Basement 02	DA.01	12/09/2025
DA-110-006	Basement 01	DA.01	12/09/2025
DA-110-007	Lower Ground	DA.01	12/09/2025
DA-110-008	Ground Level	DA.01	12/09/2025
DA-110-009	Upper Ground Level	DA.01	12/09/2025
DA-110-010	Level 01	DA.01	12/09/2025
DA-110-011	Level 02	DA.01	12/09/2025
DA-110-012	Level 03	DA.01	12/09/2025
DA-110-013	Level 04	DA.01	12/09/2025
DA-110-014	Level 05	DA.01	12/09/2025
DA-110-015	Level 06	DA.01	12/09/2025
DA-110-016	Level 07	DA.01	12/09/2025
DA-110-017	Level 08	DA.01	12/09/2025
DA-110-018	Level 09	DA.01	12/09/2025
DA-110-019	Level 10	DA.01	12/09/2025
DA-110-020	Level 11	DA.01	12/09/2025
DA-110-021	Level 12	DA.01	12/09/2025
DA-110-022	Level 13	DA.01	12/09/2025
DA-110-023	Level 14	DA.01	12/09/2025
DA-110-024	Level 15	DA.01	12/09/2025
DA-110-025	Level 16	DA.01	12/09/2025
DA-110-026	Level 17	DA.01	12/09/2025
DA-110-027	Level 18	DA.01	12/09/2025
DA-110-028	Roof Level	DA.01	12/09/2025
DA-810-001	Silver Livable Units (Page 1)	DA.01	12/09/2025
DA-810-002	Silver Livable Units (Page 2)	DA.01	12/09/2025
DA-810-003	Silver Livable Units (Page 3)	DA.01	12/09/2025
DA-810-004	Silver Livable Units (Page 4)	DA.01	12/09/2025
DA-810-005	Silver Livable Units (Page 5)	DA.01	12/09/2025
DA-810-006	Gold Livable Units	DA.01	12/09/2025
DA-810-007	Platinum Livable Units	DA.01	12/09/2025

6.0 – Copyright

6.1 The contents of this report are copyright and prepared only for the attention of the client on this project. The rights to this report are owned by Access Link Consulting Pty Ltd.

- 6.2 The contents of this report contain Standard Australia Ltd copyrighted materials and must not be reproduced, sold, published, combined with external documents or altered without the prior written permission of its distributor, SAI Global Ltd and Access Link Consulting Pty Ltd.
- 6.3 This report may be reproduced in accordance with the terms of SAI Global Ltd License 1704-c045-2 to Access Link Consulting Pty Ltd.

7.0 – Exclusions and Liabilities

- 7.1 This Clause operates simultaneously with the terms set out in Access Link Consulting Pty Ltd.'s Fee Proposal/Cost Agreement.
- 7.2 Access Link Consulting Pty Ltd is only retained for the purpose of producing information relating to Access in the context of the codes, standards, regulations and guidelines listed in Clause 4.0 of this report. Access Link Consulting Pty Ltd is not liable for producing any other information outside this context.
- 7.3 The client acknowledges the following:
- 7.3.1 This report is solely for the purpose of reviewing, identifying and advising on Access issues/Access related provisions of the BCA.
- 7.3.2 This report does not identify or cover any information, compliance matters or issues that are related to other services associated to this project.
The client is aware that it is the architect's responsibility to coordinate and check all services against the information and requirements provided in this report to ensure that compliance has been met and achieved.
- 7.3.3 This report does not identify or cover any information, compliance matters or issues in relation to the construction stage of this project.
The client is aware that it is the builder's responsibility to coordinate and check that all the information and requirements provided in this report are met and achieved during the construction stage of this project.
- 7.3.4 This report does not identify or cover checks for:
- a) Slip resistance in surfaces such as set areas, parking areas, common spaces or stairs; and/or,
b) Wall reinforcement once the walls have already been constructed.
The client is aware that it is the builder's responsibility to ensure that the requirements are met as per AS 1428.1, AS 4299, AS 2890, AS 3661, AS 4586 and any other relevant codes that may arise.
- 7.3.5 Our Report does not assess compliance matters related to the following:
- a. Work, Health and Safety;
b. Structural design;
c. Service Design; and/or,
d. Parts of the Disability Discrimination Act other than those that relate to the APS, Parts of BCA or Parts of AS other than those directly referenced in our Report.
- 7.3.6 Access Link Consulting Pty Ltd does not guarantee or warrant that our Report is correct or complete and will not be liable for any losses arising from the reliance upon or use of our Report.
- 7.3.7 Should the Client engage services with another certifier or access consultant, we are not liable if that certifier or access consultant comes to a different conclusion in their report.
- 7.4 Access Link Consulting Pty Ltd is therefore not liable for any other services that are associated to this project.
- 7.5 Except as required by law, Access Link Consulting Pty Ltd is not liable for any inaccurate or incorrect information in this report supplied by SAI Global Ltd.
- 7.6 This document/report is based on the classification of this project and the drawings set out in Clause 6.0 of this report. In the event that changes are made to the classification or drawings, this report will be deemed invalid and will be required to be updated accordingly.

Yours Sincerely,

Assessed by

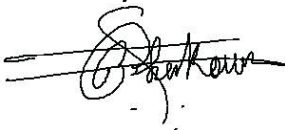

Rami Shakour
Director
ACA No. 488

Checklist Assessment Related to the Requirements Set in the BCA

The extract clauses from the NCC 2022 Amd. 2, Volume 1 – BCA below to be read in full format as set in the National Construction Code 2022 Amd. 2, Volume 1 – Building Code of Australia.

Part D4 – Access For People With Disability

D4D2 General Building Access Requirements	ADR	N/A	C
Buildings and parts of buildings must be accessible: Class 2			
I. From a pedestrian entrance required to be accessible to at least 1 floor containing sole-occupancy units.	<input type="checkbox"/>	<input type="checkbox"/>	✓
II. To the entrance doorway of each sole-occupancy unit located on that level.	<input type="checkbox"/>	<input type="checkbox"/>	✓
III. To and within each type of room or space for use in common by the residents.	<input type="checkbox"/>	<input type="checkbox"/>	✓
IV. Where a floor is accessed via an AS 1428.1 Ramp or passenger lift, all entrance doors to sole occupancy units and common spaces used by residents located on the levels served by the lift or ramp.	<input type="checkbox"/>	<input type="checkbox"/>	✓
Notes: See Att. 01 – can be compliant at the CC stage The main entry for both buildings A1 & A2 is accessible by means of a walkway and a step-free, continuous accessible path of travel from the boundary line at the lower ground level from “Middleton Ave”. The main entry for building B is accessible by means of a walkway and a step-free, continuous accessible path of travel from the boundary line at the ground level from “Carrington Rd”. The main entry for building C1 is accessible by means of a walkway and a step-free, continuous accessible path of travel from the boundary line at the ground level from “Middleton Ave”. The main entry for building C2 is accessible by means of a walkway and a step-free, continuous accessible path of travel from the boundary line at the upper ground level from “Sexton Ave”. The entrance doorway to units located on the Ground Level is also accessible. Furthermore, all common areas are accessible to the residents via a step-free, continuous accessible path of travel.			
Class 7a			
• To and within any level containing accessible car parking spaces. Notes: See Att. 01 – can be compliant at the CC stage	<input type="checkbox"/>	<input type="checkbox"/>	✓
D4D3 Access To Buildings	ADR	N/A	C
(a) Access way must be provided to a building;			
I. From the main points of a pedestrian entry at the allotment boundary	<input type="checkbox"/>	<input type="checkbox"/>	✓
II. From another accessible building connected by a pedestrian link	<input type="checkbox"/>	✓	<input type="checkbox"/>
III. From any required accessible car parking space on the allotment	<input type="checkbox"/>	<input type="checkbox"/>	✓
Reference: Figure 06, Figure 18, Figure 19 Notes: See Att. 01 – can be compliant at the CC stage Access way is provided from the allotment boundary via means of a walkway and a step-free, continuous accessible path of travel			
(b) In a building required to be accessible,			
I. an accessway must be provided through the principal pedestrian entrance,	<input type="checkbox"/>	<input type="checkbox"/>	✓
II. through not less than 50% of all pedestrian entrances including the principal pedestrian entrance; and	<input type="checkbox"/>	<input type="checkbox"/>	✓
III. in a building with a total floor area more than 500 m2, a pedestrian entrance which is not accessible must not be located more than 50 m from an accessible pedestrian entrance.	<input type="checkbox"/>	<input type="checkbox"/>	✓
Notes: See Att. 01 – can be compliant at the CC stage Access way is provided through the main principal pedestrian entrance via means of a walkway and a step-free continuous accessible path of travel			

<p>(c) Where a pedestrian entrance required to be accessible has multiple doorways—</p> <ol style="list-style-type: none"> I. if the pedestrian entrance consists of not more than 3 doorways — not less than 1 of those doorways must be accessible; II. if a pedestrian entrance consists of more than 3 doorways — not less than 50% of those doorways must be accessible <p>Notes: See Att. 01 – can be compliant at the CC stage</p>	<input type="checkbox"/> <input type="checkbox"/>	<input type="checkbox"/> <input checked="" type="checkbox"/>	<input checked="" type="checkbox"/> <input type="checkbox"/>															
<p>(d) Access way must have a clear opening of 850mm in accordance with 1428.1 Reference: Figure 29, Figure 29(A), Figure 29(B) Notes: See Att. 01 – can be compliant at the CC stage</p>	<input type="checkbox"/>	<input type="checkbox"/>	<input checked="" type="checkbox"/>															
D4D4 Access To Buildings	ADR	N/A	C															
<p>(a) every ramp and stairway must comply with;</p> <ol style="list-style-type: none"> I. For a ramp, clause 7 of AS 1428.1 II. For a stairway, clause 8 of AS 1428.1 III. For a fire isolated stair, clause 8.1(f) and (g) of AS 1428.1 <p>Reference: Figure 06, Figures 11 to 21 Notes: See Att. 01 – can be compliant at the CC stage</p>	<input type="checkbox"/> <input type="checkbox"/> <input type="checkbox"/>	<input type="checkbox"/> <input type="checkbox"/> <input type="checkbox"/>	<input checked="" type="checkbox"/> <input checked="" type="checkbox"/> <input checked="" type="checkbox"/>															
<p>(b) every passenger lift must comply with E3D7 and E3D8 Notes: Can be compliant at the CC stage – This has been assessed in further detail in Part E3 further in this report</p>	<input type="checkbox"/>	<input type="checkbox"/>	<input checked="" type="checkbox"/>															
<p>(c) access ways must have;</p> <ol style="list-style-type: none"> I. Passing spaces complying with AS 1428.1 II. Turning spaces complying with AS 1428.1 <ol style="list-style-type: none"> i. Within 2m of the end of access ways where it is not possible to continue. ii. at maximum 20m intervals along the access way <p>Reference: Figure 01, Figure 02, Figure 03 Notes: See Att. 01 – can be compliant at the CC stage</p>	<input type="checkbox"/> <input type="checkbox"/> <input type="checkbox"/>	<input type="checkbox"/> <input type="checkbox"/> <input type="checkbox"/>	<input checked="" type="checkbox"/> <input checked="" type="checkbox"/> <input checked="" type="checkbox"/>															
<p>(d) an intersection of access way satisfies the spatial requirements for a passing and turning space Reference: Figure 01 Notes: See Att. 01 – can be compliant at the CC stage</p>	<input type="checkbox"/>	<input type="checkbox"/>	<input checked="" type="checkbox"/>															
<p>(e) a passing space may serve as a turning space Reference: Figure 01 Notes: See Att. 01 – can be compliant at the CC stage</p>	<input type="checkbox"/>	<input type="checkbox"/>	<input checked="" type="checkbox"/>															
<p>(f) a ramp complying with AS 1428.1 or a passenger lift need not be provided to serve a storey or level other than the entrance storey in class 5, 6, 7b or 8</p> <ol style="list-style-type: none"> I. Containing not more than 3 storeys and II. With a floor area for each storey, excluding the entrance storey, of not more than 200m² 	<input type="checkbox"/>	<input checked="" type="checkbox"/>	<input type="checkbox"/>															
<p>Slip Resistance Requirements as per the BCA</p> <p>BCA table D3D15 has the following slip resistance requirements/classification when tested in accordance with AS4586</p> <p>Table D3D15: Slip-resistance classification</p> <table border="1" data-bbox="183 1780 1173 1960"> <thead> <tr> <th>Application</th> <th>Dry surface conditions</th> <th>Wet surface conditions</th> </tr> </thead> <tbody> <tr> <td>Ramp steeper than 1:14</td> <td>P4 or R11</td> <td>P5 or R12</td> </tr> <tr> <td>Ramp steeper than 1:20 but not steeper than 1:14</td> <td>P3 or R10</td> <td>P4 or R11</td> </tr> <tr> <td>Tread or landing surface</td> <td>P3 or R10</td> <td>P4 or R11</td> </tr> <tr> <td>Nosing or landing edge strip</td> <td>P3</td> <td>P4</td> </tr> </tbody> </table> <p>Notes: Can be compliant at the CC stage – the builder must provide a certificate stating that the slip resistance of all surfaces complies with the above table D3D15 when tested in accordance with AS4586</p>	Application	Dry surface conditions	Wet surface conditions	Ramp steeper than 1:14	P4 or R11	P5 or R12	Ramp steeper than 1:20 but not steeper than 1:14	P3 or R10	P4 or R11	Tread or landing surface	P3 or R10	P4 or R11	Nosing or landing edge strip	P3	P4	<input type="checkbox"/>	<input type="checkbox"/>	<input checked="" type="checkbox"/>
Application	Dry surface conditions	Wet surface conditions																
Ramp steeper than 1:14	P4 or R11	P5 or R12																
Ramp steeper than 1:20 but not steeper than 1:14	P3 or R10	P4 or R11																
Tread or landing surface	P3 or R10	P4 or R11																
Nosing or landing edge strip	P3	P4																

All braille and tactile signage must comply with Specification D4D7 braille and tactile signs Reference: Figure 25 Notes: See Att. 01 – Notes on plans	<input type="checkbox"/>	<input type="checkbox"/>	✓
D4D8 Hearing augmentation	ADR	N/A	C
(a) a hearing augmentation system must be provided where an inbuilt amplification system other than the one used only for emergency warning, is installed;			
I. In a room in a Class 9b building	<input type="checkbox"/>	✓	<input type="checkbox"/>
II. In an auditorium, conference room, meeting room or room for judicatory purposes	<input type="checkbox"/>	✓	<input type="checkbox"/>
III. At any ticket office, teller's booth, reception area or the like, where the public is screened from the service provider	<input type="checkbox"/>	✓	<input type="checkbox"/>
D4D9 Tactile indicators	ADR	N/A	C
(a) For a building required to be accessible, tactile ground surface indicators must be provided to warn people who are blind or have a vision impairment that they are approaching—			
A stairway, other than a fire-isolated stairway.	<input type="checkbox"/>	<input type="checkbox"/>	✓
An escalator.	<input type="checkbox"/>	✓	<input type="checkbox"/>
A passenger conveyor or moving walk.	<input type="checkbox"/>	✓	<input type="checkbox"/>
A ramp other than a fire-isolated ramp, step ramp, kerb ramp or swimming pool ramp.	<input type="checkbox"/>	<input type="checkbox"/>	✓
Under an overhead obstruction less than 2 m above floor level, other than a doorway if no barrier is present.	<input type="checkbox"/>	✓	<input type="checkbox"/>
Or when an access way meets a vehicular way adjacent to any pedestrian entrance to a building, if there is no kerb or kerb ramp present.	<input type="checkbox"/>	✓	<input type="checkbox"/>
Reference: Figure 05, Figure 06, Figure 08 Notes: See Att. 01 – can be compliant at the CC stage			
(b) Tactile ground surface indicators must comply with sections 1 and 2 of AS/NZS 1428.4.1. Reference: Figure 05 Notes: See Att. 01 – can be compliant at CC stage	<input type="checkbox"/>	<input type="checkbox"/>	✓
(c) A hostel for the aged, nursing home for the aged, a residential aged care building Class 3 accommodation for the aged, Class 9a health-care building or a Class 9c building need not comply with (a)(i) and (iv) if handrails incorporating a raised dome button in accordance with the requirements for stairway handrails in AS 1428.1 are provided to warn people who are blind or have a vision impairment that they are approaching a stairway or ramp.	<input type="checkbox"/>	✓	<input type="checkbox"/>
D4D10 Wheelchair seating spaces in Class 9b assembly buildings	ADR	N/A	C
Only applicable for class 9b building	<input type="checkbox"/>	✓	<input type="checkbox"/>

D4D11 Swimming pools	ADR	N/A	C
<p>(1) Not less than 1 means of accessible water entry/exit in accordance with Specification 16 must be provided for each swimming pool required by D4D2 to be accessible.</p> <p>(2) An accessible entry/exit must be by means of— (a) a fixed or movable ramp and an aquatic wheelchair; or (b) a zero depth entry and an aquatic wheelchair; or (c) a platform swimming pool lift and an aquatic wheelchair; or (d) a sling-style swimming pool lift.</p> <p>(3) Where a swimming pool has a perimeter of more than 70 m, at least one accessible water entry/exit must be provided by a means specified in (2)(a), (b) or (c).</p> <p>(4) Latching devices on gates and doors forming part of a swimming pool safety barrier need not comply with AS 1428.1.</p> <p>Notes: See Att. 01 – all pools are to be accessible and can be compliant at CC stage</p>	<input type="checkbox"/>	<input type="checkbox"/>	<input checked="" type="checkbox"/>
D4D12 Ramps	ADR	N/A	C
<p>(a) a series of connected ramps must not have a combined vertical rise of more than 3.6m (b) a landing for a step ramp must not overlap a landing for another step ramp or ramp</p> <p>Notes: See Att. 01 – can be compliant at CC stage</p>	<input type="checkbox"/> <input type="checkbox"/>	<input type="checkbox"/> <input checked="" type="checkbox"/>	<input checked="" type="checkbox"/> <input type="checkbox"/>
D4D13 Glazing on an access way	ADR	N/A	C
<p>On an access way where there is no chair rail, handrail or transom, all frameless or fully glazed doors, sidelights and any glazing capable of being mistaken for a doorway or opening, must be clearly marked in accordance with AS 1428.1</p> <p>Reference: Figure 22</p> <p>Notes: Can be compliant at CC stage – selection of glazing strips as specified in this section will lead to compliance at the construction stage. This is to be confirmed at the CC stage.</p>	<input type="checkbox"/>	<input type="checkbox"/>	<input checked="" type="checkbox"/>



Part D4 – References

The references below to be read as set and referenced in each section of part D4

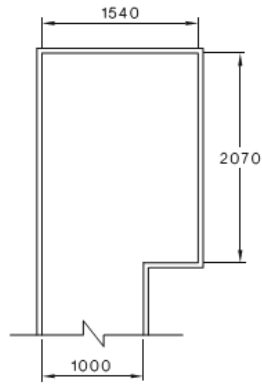

(a) Space required in corridor

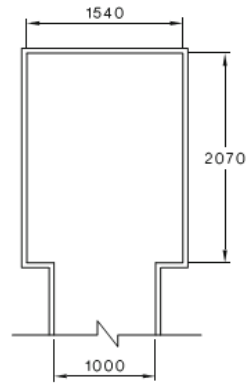

(b) Space required in corridor

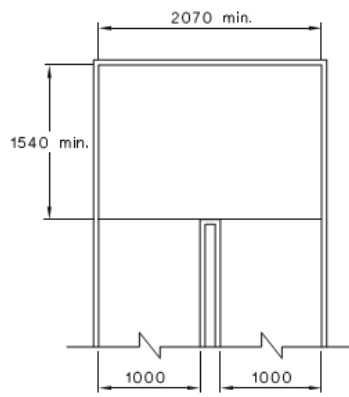

(c) Space required at ramp landing

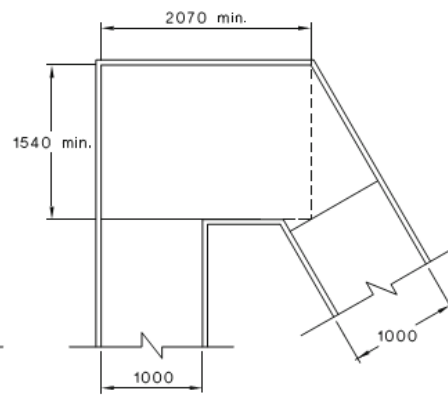

(d) Space required at ramp landing

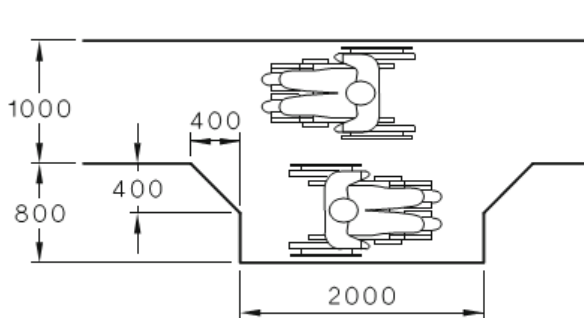
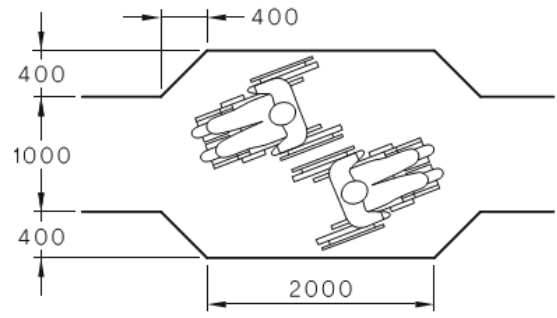

Figure 01



SAI Global Ltd License 1704-c045-2

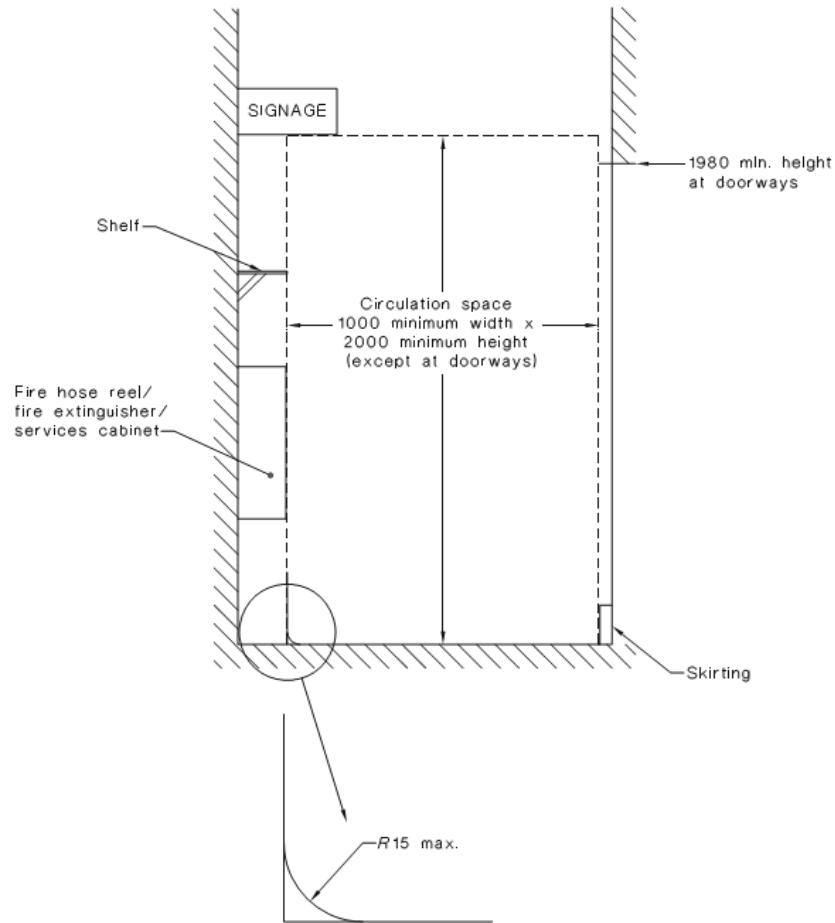

Figure 02

SAI Global Ltd License 1704-c045-2

Unless otherwise specified (such as at doors, curved ramps and similar), the minimum unobstructed width (see Figure 2) of a continuous accessible path of travel shall be 1000 mm and the following shall not intrude into the minimum unobstructed width of a continuous accessible path of travel:

- (a) Fixtures and fittings such as lights, awnings, windows that, when open, intrude into the circulation space, telephones, skirtings and similar objects.
- (b) Essential fixtures and fittings such as fire hose reels, fire extinguishers and switchboards.
- (c) Door handles less than 900 mm above the finished floor level.

Figure 03

SAI Global Ltd License 1704-c045-2

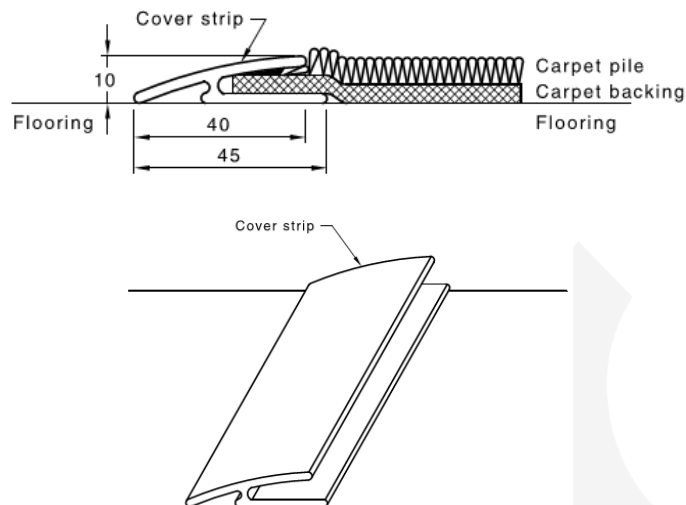

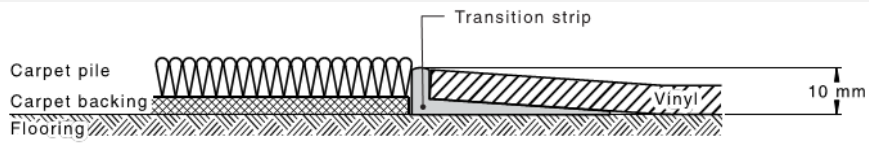

Figure 04

SAI Global Ltd License 1704-c045-2

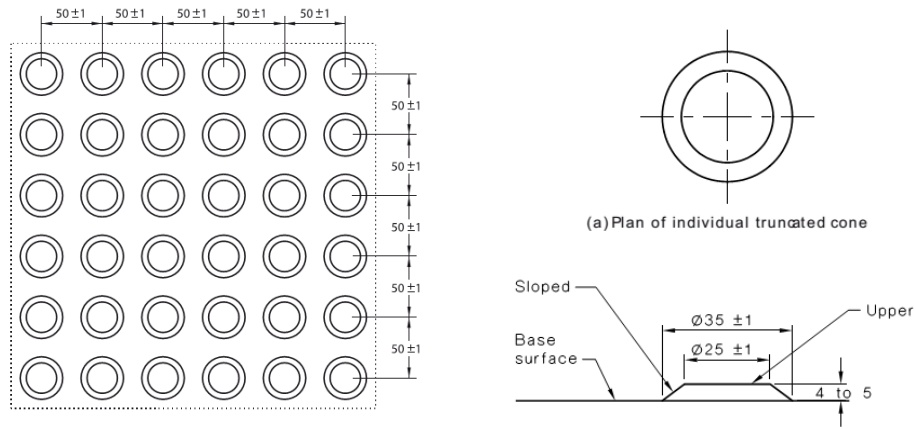

Figure 05

SAI Global Ltd License 1704-c045-2

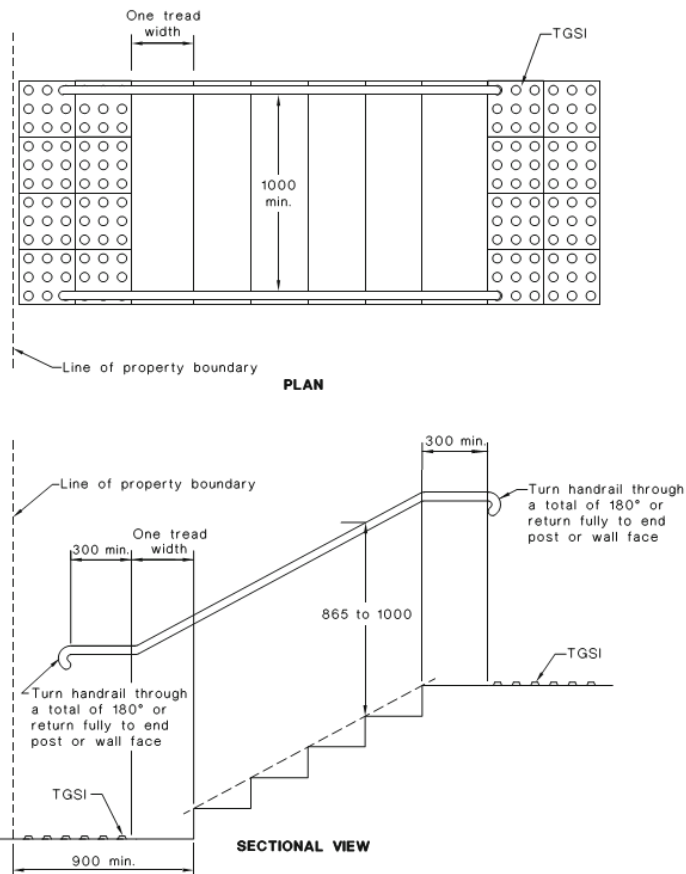
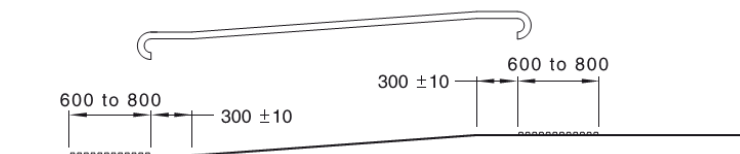

Figure 06

SAI Global Ltd License 1704-c045-2



(c) Side elevation where top and bottom of ramp leads to an open area

Figure 08

SAI Global Ltd License 1704-c045-2

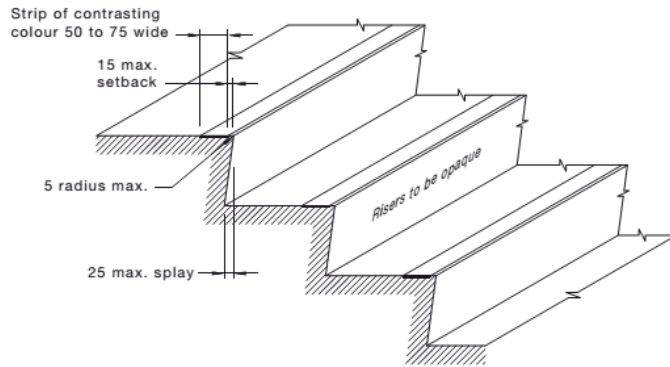

NOTE: A chamfered nosing 5 x 5 mm may be used.

DIMENSIONS IN MILLIMETRES

FIGURE 27(A) A TYPICAL STAIR NOSING PROFILE WITH NOSING STRIP

Figure 11

SAI Global Ltd License 1704-c045-2

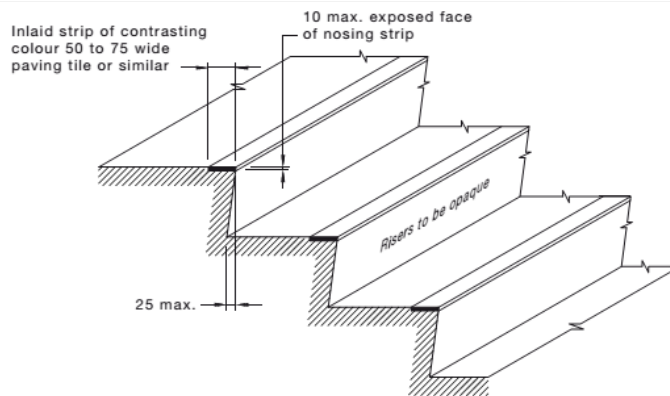

DIMENSIONS IN MILLIMETRES

FIGURE 27(B) A TYPICAL STAIR NOSING PROFILE WITH EXPOSED NOSING STRIP

Figure 12

SAI Global Ltd License 1704-c045-2

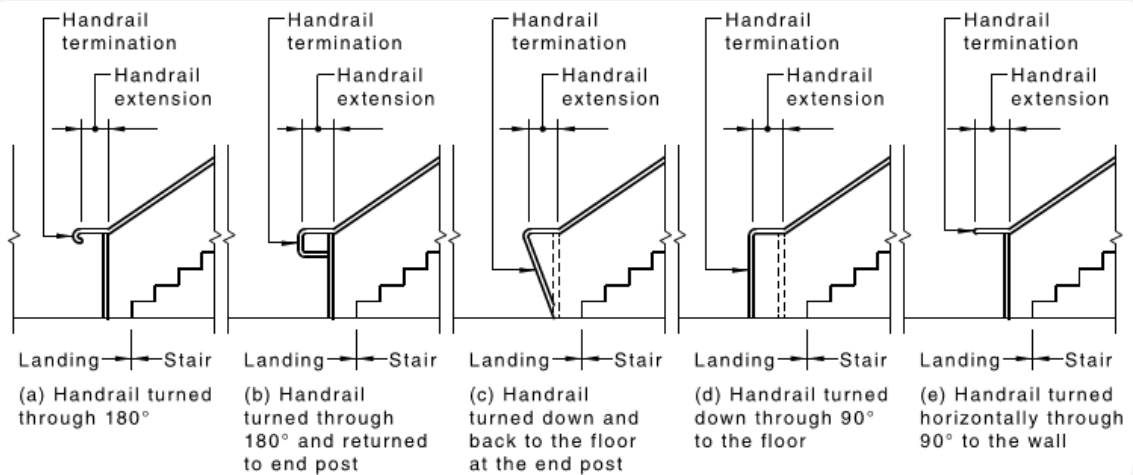

Side elevations

(a) Examples of post mounted handrails

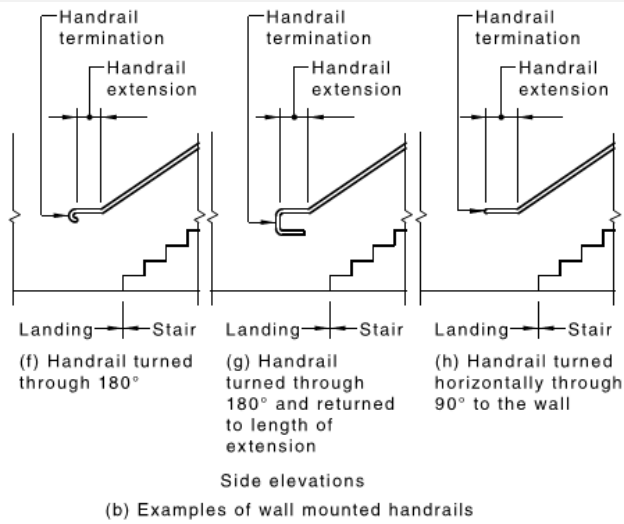

Stair handrails – Example of handrail termination

Figure 14

SAI Global Ltd License 1704-c045-2

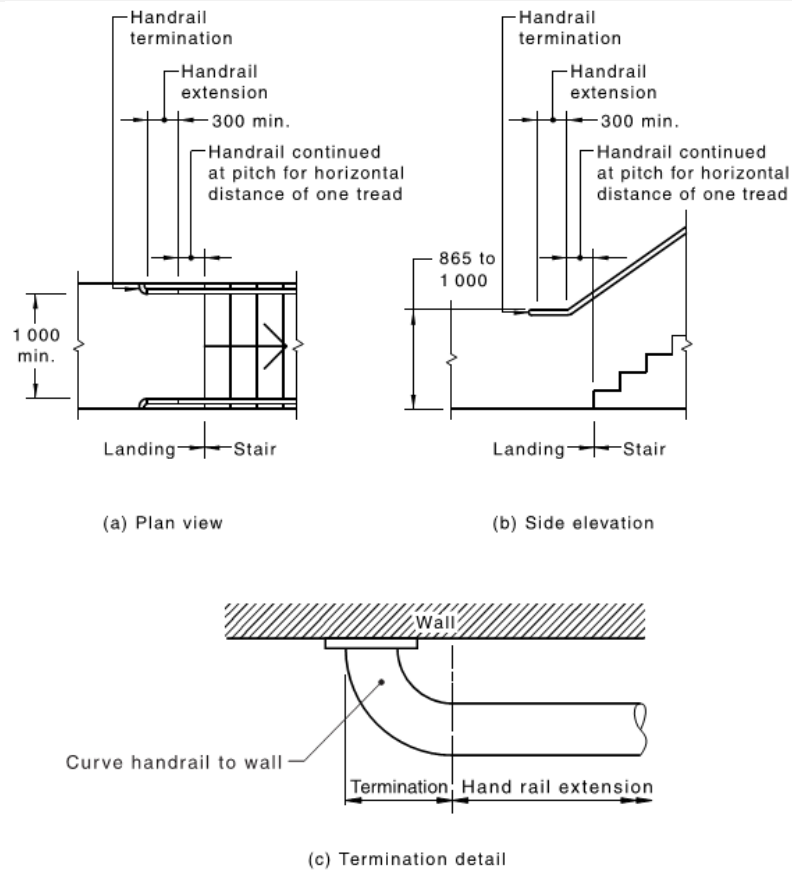

Example of detail for handrails terminated by turning horizontally through 90 degrees to the wall

Figure 15

SAI Global Ltd License 1704-c045-2

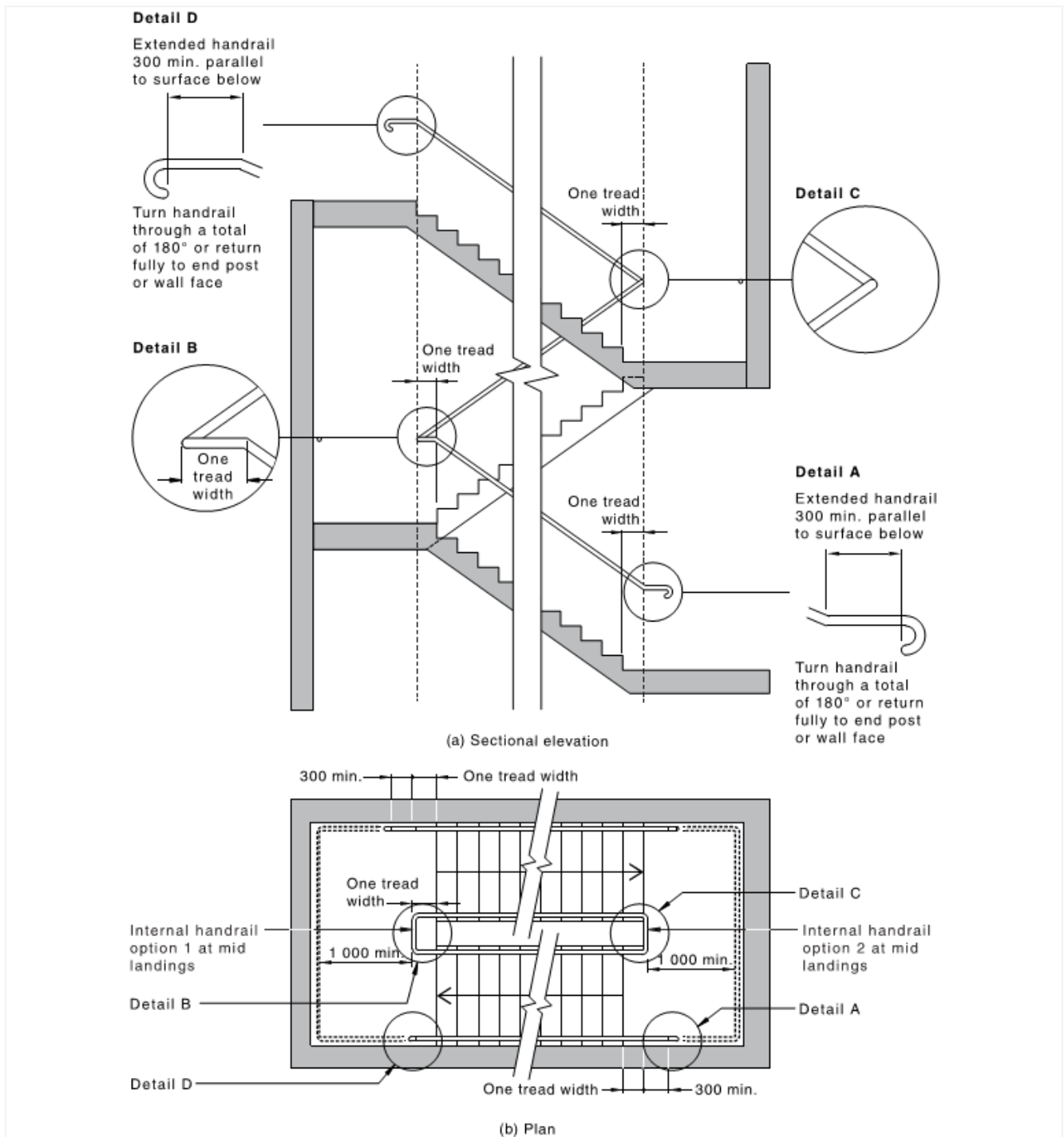

Figure 16

SAI Global Ltd License 1704-c045-2

(a) Handrails and balustrades shall not encroach into required circulation spaces.

(b) The cross-section of handrails shall be circular or elliptical, not less than 30 mm or greater than 50 mm in height or width for not less than 270° around the uppermost surface as shown in the Figures below. Elliptical handrails shall have the greater dimension in the horizontal axis as shown in Figure below.

(c) Exposed edges at ends and corners of handrails shall have a radius of not less than 5 mm.

(d) The top of handrails shall be not less than 865 mm nor more than 1000 mm above the nosing of stairway tread or the plane of the finished floor of the walkway, ramp or landing.

(e) The height of the top of the handrail, measured in accordance with Item (d), shall be consistent through the ramp (or stairs) and any landings.

- (f) If a balustrade is required at a height greater than the handrail, both shall be provided.
- (g) Handrails shall be securely fixed and rigid, and their ends shall be turned through a total of 180°, or to the ground, or returned fully to end post or wall face, as shown in Figures 14 and 15.
- (h) The clearance between a handrail and an adjacent wall surface or other obstruction shall be not less than 50 mm. This clearance shall extend above the top of the handrail by not less than 600 mm.
- (i) Handrails shall have no obstruction to the passage of a hand along the rail, as shown in below.
- (j) The inside handrail at landings shall always be continuous, as shown in Figure 16.

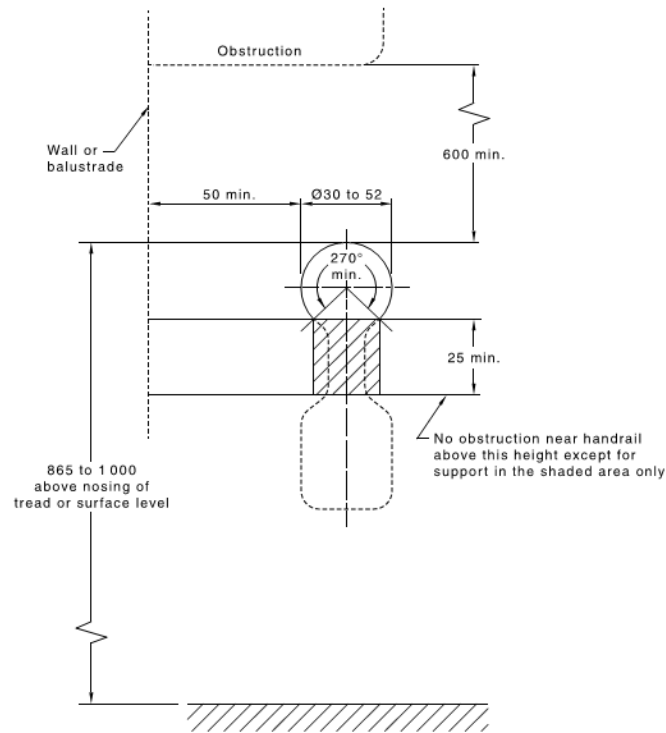

(a) Circular

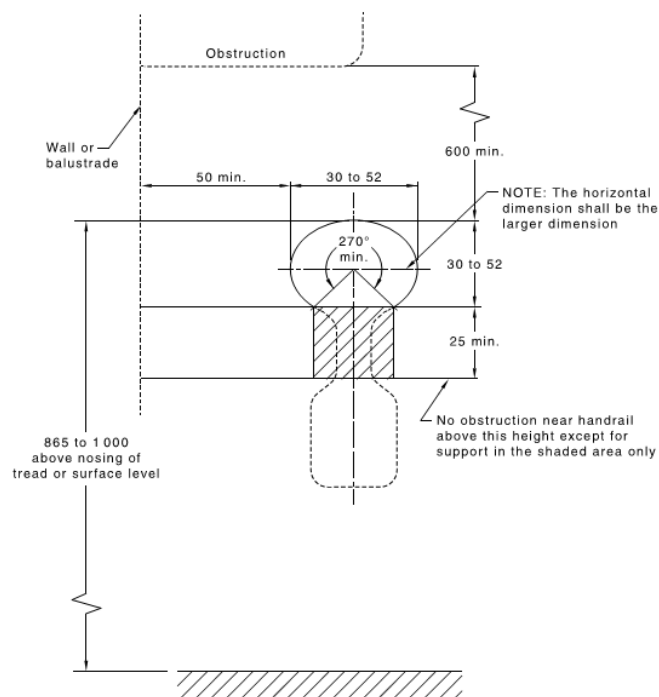

(b) Elliptical

Figure 17

SAI Global Ltd License 1704-c045-2

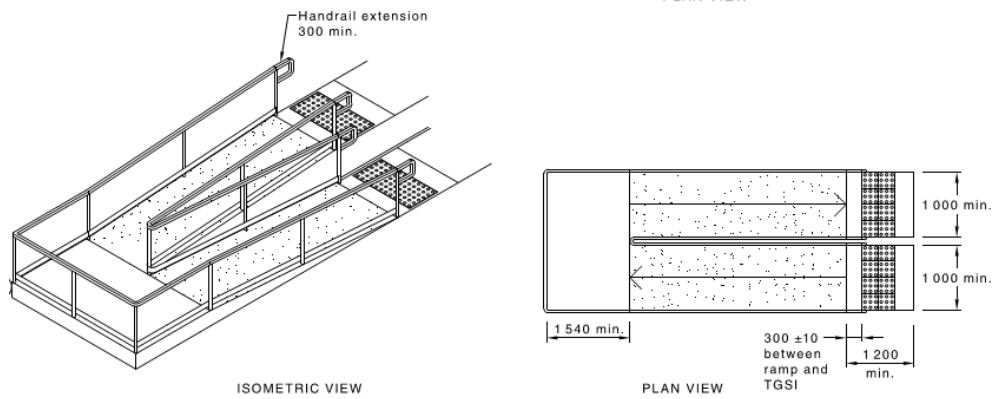
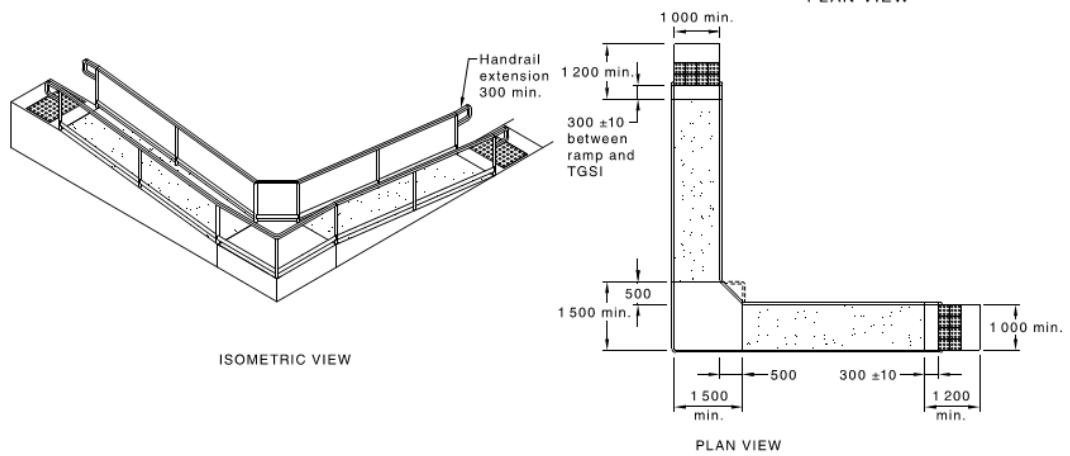
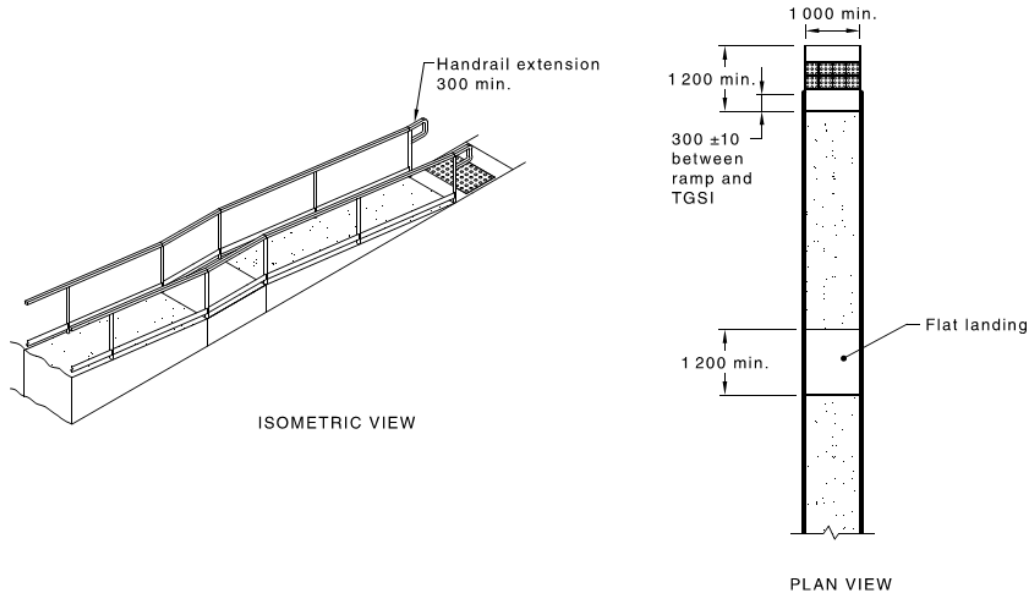

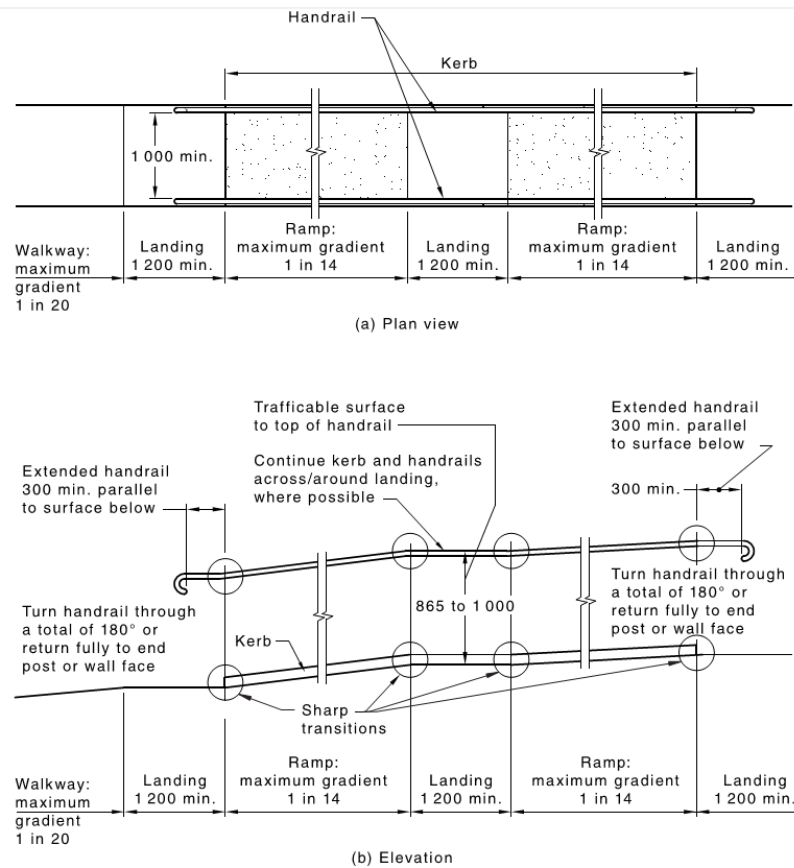

Figure 18

SAI Global Ltd License 1704-c045-2

Walkways

Walkways shall be in accordance with the following:

- (a) The floor or ground surface abutting the sides of the walkway shall provide a firm and level surface of a different material to that of the walkway at the same level of the walkway, follow the grade of the walkway and extend horizontally for a minimum of 600 mm unless one of the following is provided:
- (i) Kerb in accordance with the Figure “*kerb*” below; or
 - (ii) Kerb rail and handrail in accordance with the Figure “*kerb or kerb rail options*” below; or
 - (iii) A wall, fence, balustrade or similar barrier.

In the case of a street kerb, the minimum width of the walkway shall be increased by 600 mm at that side as shown in Figures “*attached kerb ramp*” and “*In line kerb ramps – Narrow footpath*”.

- (b) Walkways shall be provided with landings, as specified and listed below section “*Landings*”, at intervals not exceeding the following:
- (i) For walkway gradients of 1 in 33, at intervals no greater than 25 m.
 - (ii) For walkway gradients of 1 in 20, at intervals no greater than 15 m.
 - (iii) For walkway gradients between 1 in 20 to 1 in 33, at intervals that shall be obtained by linear interpolation.

For walkways shallower than 1 in 33, no landings are required.

The intervals specified above may be increased by 30 % where at least one side of a walkway is bounded by —

- (iv) a kerb or kerb rail as specified in point (1) below and a handrail as specified in Figure 17; **or**
 - 1- Where a handrail is not supported on a wall, ramps and intermediate landings shall have kerbs or kerb rails in accordance with the following:
 - (i) The minimum height above the finished floor shall be 65 mm.
 - (ii) The height of the top of the kerb or kerb rail shall not be within the range 75 mm to 150 mm

Selection showing the location of the kerb or kerb rail in relation to the handrail with vertical support

Figure 19

SAI Global Ltd License 1704-c045-2

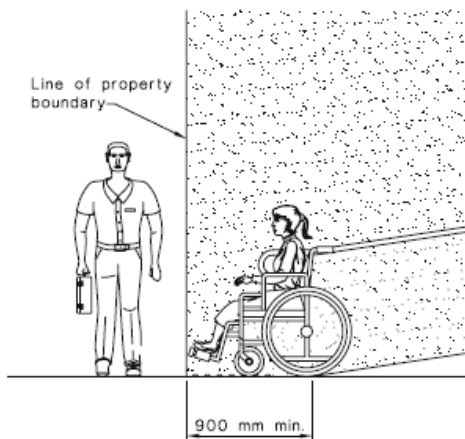
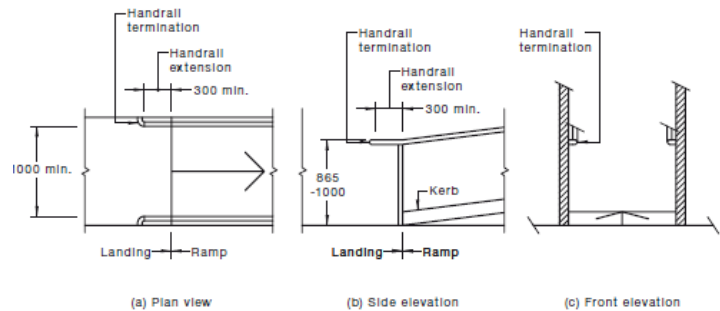

Figure 20 SAI Global Ltd License 1704-c045-2



DIMENSIONS IN MILLIMETRES

Figure 21

SAI Global Ltd License 1704-c045-2

Visual indicators on glazing

Where there is no chair rail, handrail or transom, all frameless or fully glazed doors, sidelights, including any glazing capable of being mistaken for a doorway or opening, shall be clearly marked for their full width with an unbroken, solid and opaque contrasting line. The contrasting line shall be not less than 75 mm high and shall extend across the full width of the glazing panel. The lower edge of the contrasting line shall be located between 900 mm and 1 000 mm above the plane of the finished floor level.

Any contrasting line on the glazing shall provide a minimum of 30 % luminance contrast when viewed against the floor surface or surfaces within 2 m of the glazing on the opposite side. The contrast shall be achieved when viewed from each side of the glazing.

The opacity of the line shall be tested by observing a solid object placed immediately behind and touching the glass. The line shall be considered opaque if there is no image of the object visible.

NOTE 1 On tinted glass, the contrast of the strip may be more appropriately considered against the glass tint than the floor beyond.

NOTE 2 Any logo, branding, company name or the like may be added to the visual indicator strip, but these should be fully above, or fully below the minimum 75 mm wide unbroken, solid and opaque contrasting line.

NOTE 3 AS 1288:2006 Section 5 provides further information relating to the criteria and situations relevant to glazing that is more vulnerable to human impact.

Figure 22

SAI Global Ltd License 1704-c045-2



Figure 23

SAI Global Ltd License 1704-c045-2



Figure 24

SAI Global Ltd License 1704-c045-2

3. Braille and tactile sign specification

- (a) Tactile characters must be raised or embossed to a height of not less than 1 mm and not more than 1.5 mm.
- (b) Sentence case (upper case for the first letter of each main word and lower case for all other letters) must be used for all tactile characters, and—
 - (i) upper case tactile characters must have a height of not less than 15 mm and not more than 55 mm, except that the upper case tactile characters on a sign identifying a door *required* by E4.5 to be provided with an *exit* sign must have a height of not less than 20 mm and not more than 55 mm; and
 - (ii) lower case tactile characters must have a height of 50% of the related upper case characters.
- (c) Tactile characters, symbols, and the like, must have rounded edges.
- (d) The entire sign, including any frame, must have all edges rounded.
- (e) The background, negative space or fill of signs must be of matt or low sheen finish.
- (f) The characters, symbols, logos and other features on signs must be matt or low sheen finish.
- (g) The minimum letter spacing of tactile characters on signs must be 2 mm.
- (h) The minimum word spacing of tactile characters on signs must be 10 mm.
- (i) The thickness of letter strokes must be not less than 2 mm and not more than 7 mm.
- (j) Tactile text must be left justified, except that single words may be centre justified.
- (k) Tactile text must be Arial typeface.

4. Luminance contrast

The following applies to *luminance contrast*.

- (a) The background, negative space, fill of a sign or border with a minimum width of 5 mm must have a *luminance contrast* with the surface on which it is mounted of not less than 30%.
- (b) Tactile characters, icons and symbols must have a minimum *luminance contrast* of 30% to the surface on which the characters are mounted.
- (c) *Luminance contrasts* must be met under the lighting conditions in which the sign is to be located.

Figure 25

SAI Global Ltd License 1704-c045-2

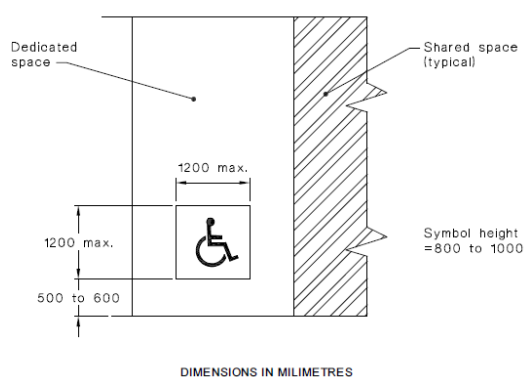

Figure 26 SAI Global Ltd License 1704-c045-2

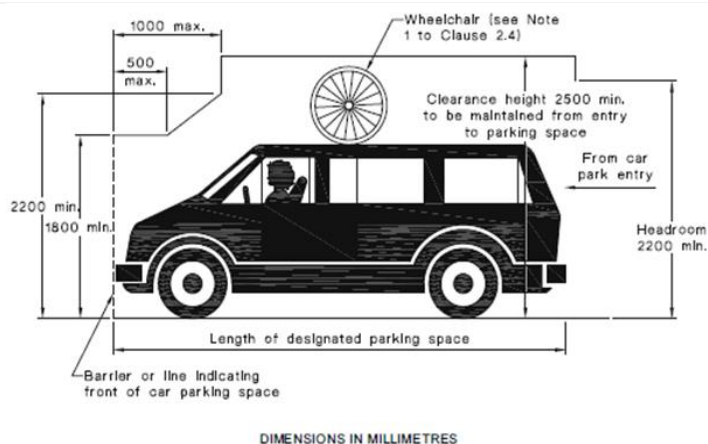

Figure 27

SAI Global Ltd License 1704-c045-2

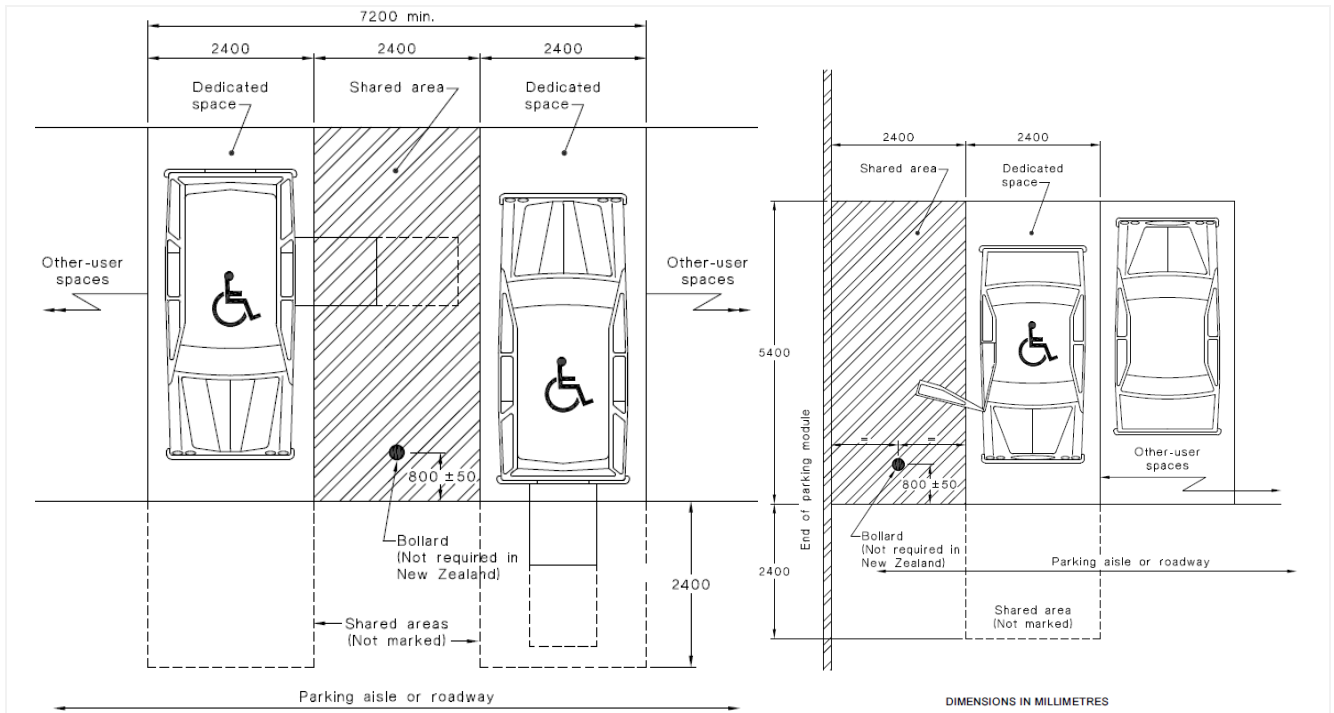
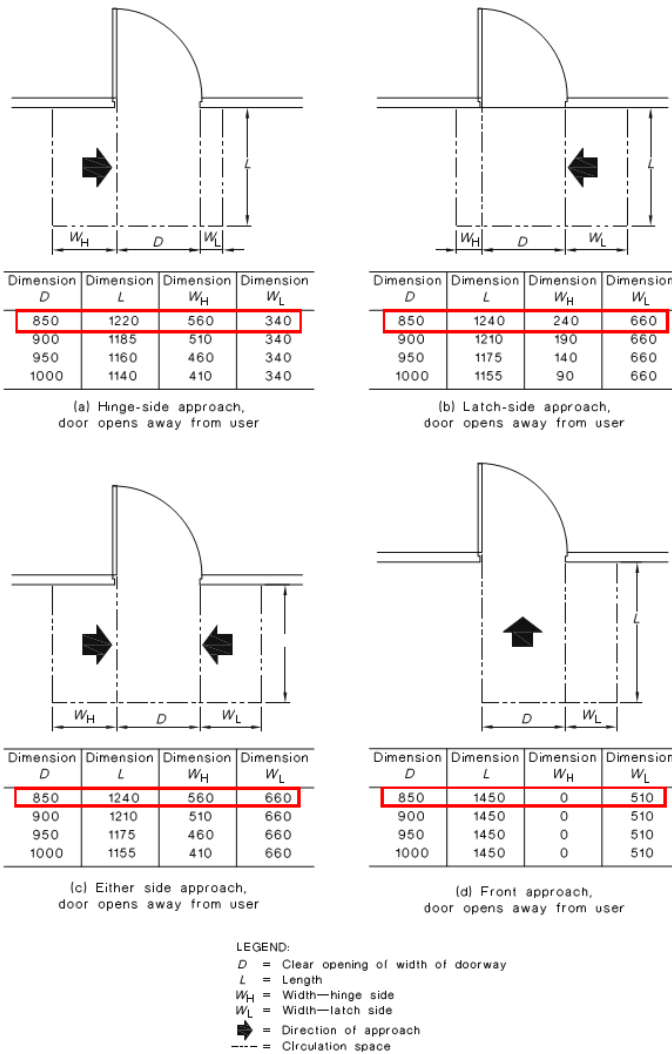
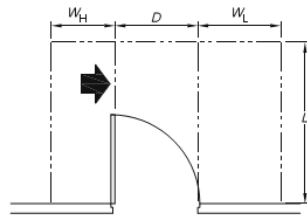

Figure 28

SAI Global Ltd License 1704-c045-2





Dimension D	Dimension L	Dimension W _H	Dimension W _L
850	1670	660	900
900	1670	610	900
950	1670	560	900
1000	1670	510	900

(e) Hinge-side approach, door opens towards user

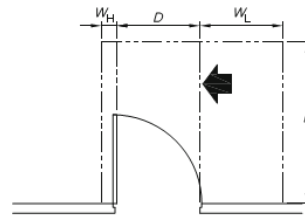

Dimension D	Dimension L	Dimension W _H	Dimension W _L
850	1670	110	900
900	1670	110	900
950	1670	110	900
1000	1670	110	900

(f) Latch-side approach, door opens towards user

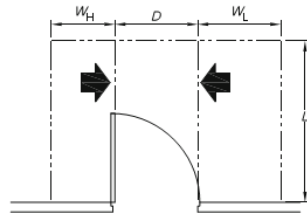

Dimension D	Dimension L	Dimension W _H	Dimension W _L
850	1670	660	900
900	1670	610	900
950	1670	560	900
1000	1670	510	900

(g) Either side approach, door opens towards user

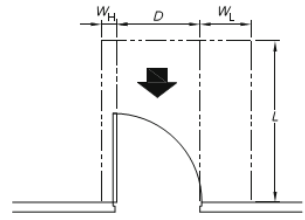

Dimension D	Dimension L	Dimension W _H	Dimension W _L
850	1450	110	530
900	1450	110	530
950	1450	110	530
1000	1450	110	530

(h) Front approach, door opens towards user

LEGEND:
 D = Clear opening of width of doorway
 L = Length
 W_H = Width—hinge side
 W_L = Width—latch side
 → = Direction of approach
 --- = Circulation space

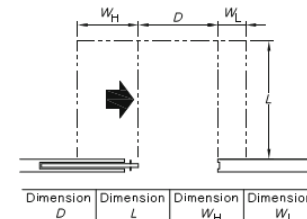

Dimension D	Dimension L	Dimension W _H	Dimension W _L
850	1280	660	395
900	1280	610	395
950	1280	560	395
1000	1280	510	395

(a) Slide-side approach

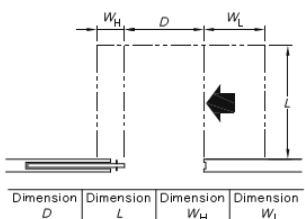

Dimension D	Dimension L	Dimension W _H	Dimension W _L
850	1230	185	660
900	1230	180	660
950	1230	180	660
1000	1230	180	660

(b) Latch-side approach

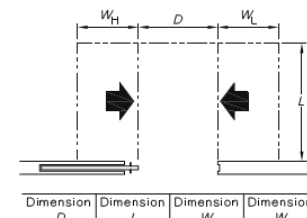

Dimension D	Dimension L	Dimension W _H	Dimension W _L
850	1280	660	660
900	1280	610	660
950	1280	560	660
1000	1280	510	660

(c) Either side approach

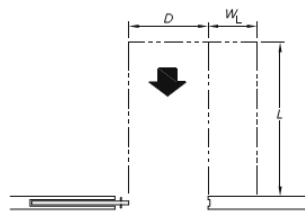

Dimension D	Dimension L	Dimension W _H	Dimension W _L
850	1450	0	530
900	1450	0	530
950	1450	0	530
1000	1450	0	530

(d) Front approach

LEGEND:
 D = Clear opening of width of doorway
 L = Length
 W_H = Width—hinge side
 W_L = Width—latch side
 → = Direction of approach
 --- = Circulation space

Figure 29

SAI Global Ltd License 1704-c045-2

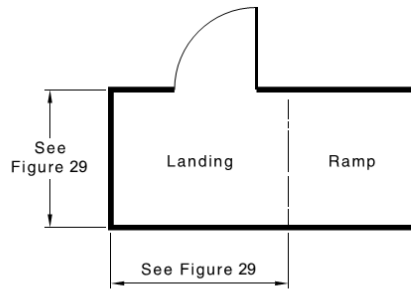

(a) Door opens away from a landing, hinge-side approach

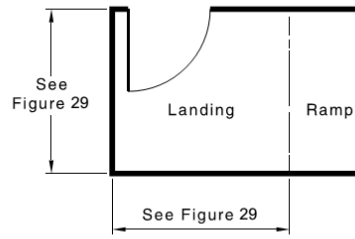

(b) Door opens towards a landing, latch-side approach

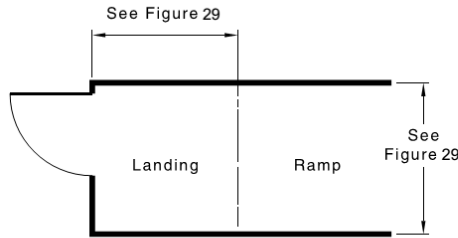

(c) Door opens away from a landing, front approach

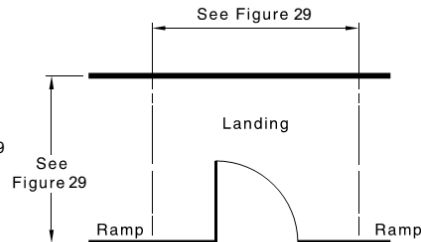

(d) Door opens towards a landing, either approach

Figure 29(A)

SAI Global Ltd License 1704-c045-2

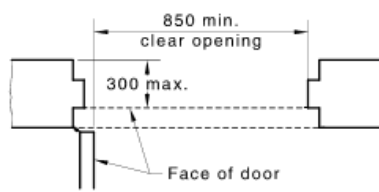

(a) Swing door

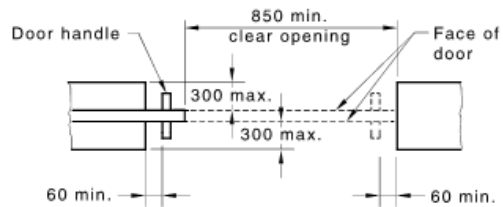

(b) Cavity sliding door

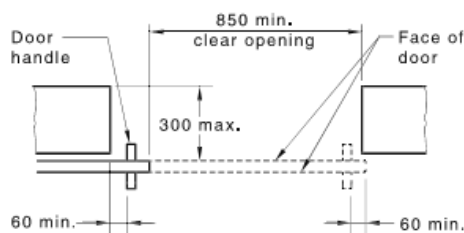

(c) Surface-mounted sliding door

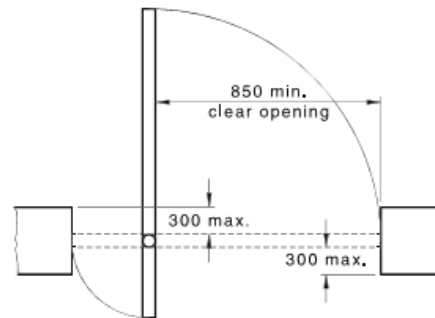

(d) Pivot hinge door

Figure 29(B)

SAI Global Ltd License 1704-c045-2

Part D4 – Attachments

The attachments below are extracted from the Architectural Plans provided and are to be read as set and referenced in each section of part D4

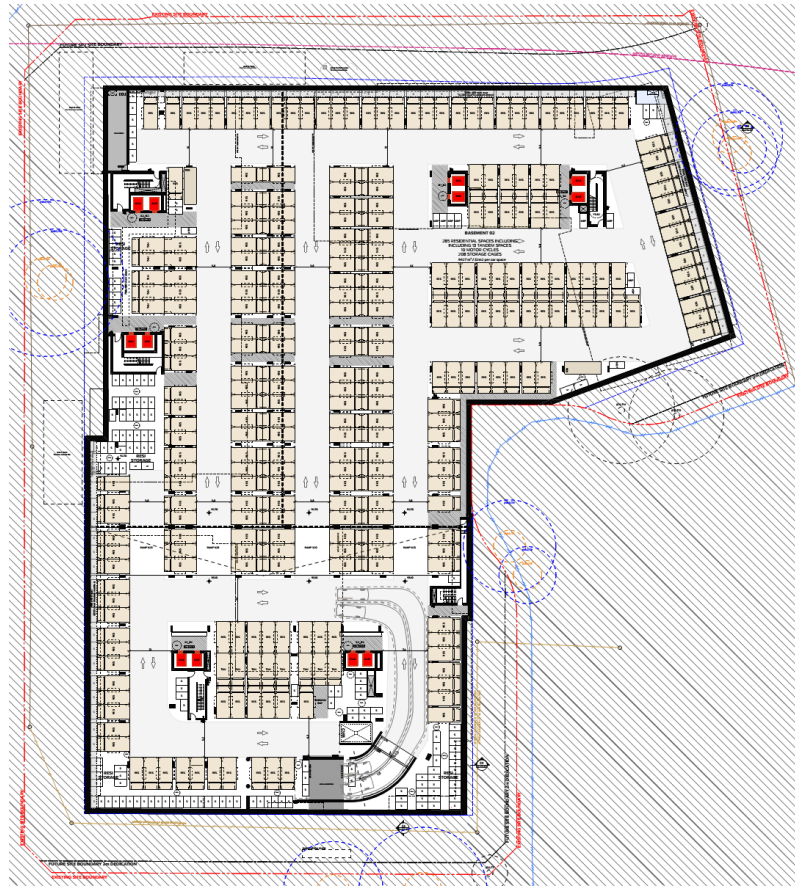

Basement 02

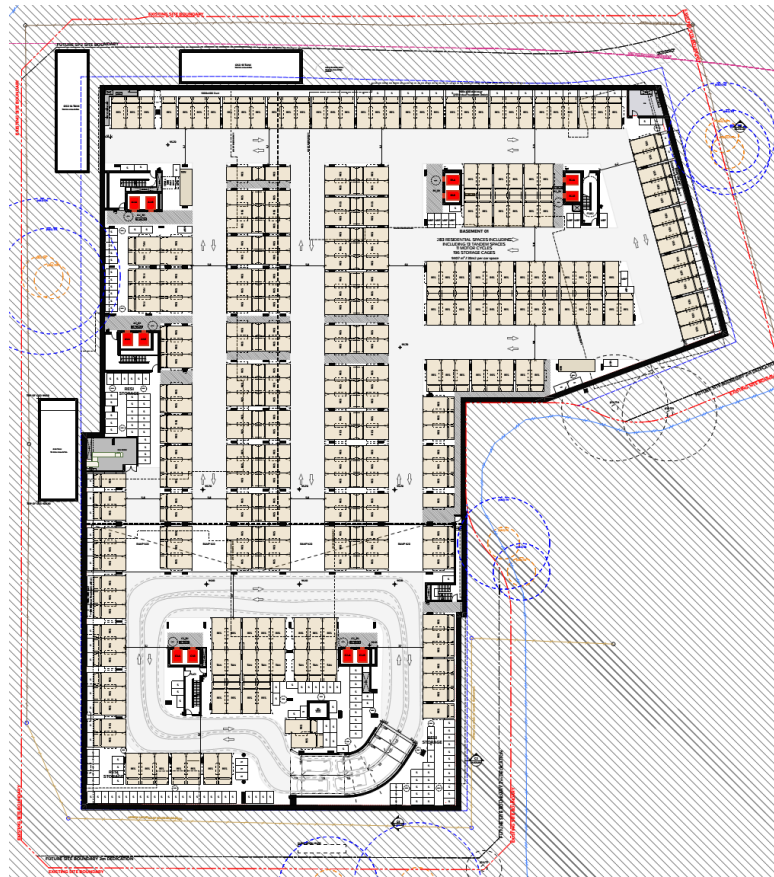

Basement 01

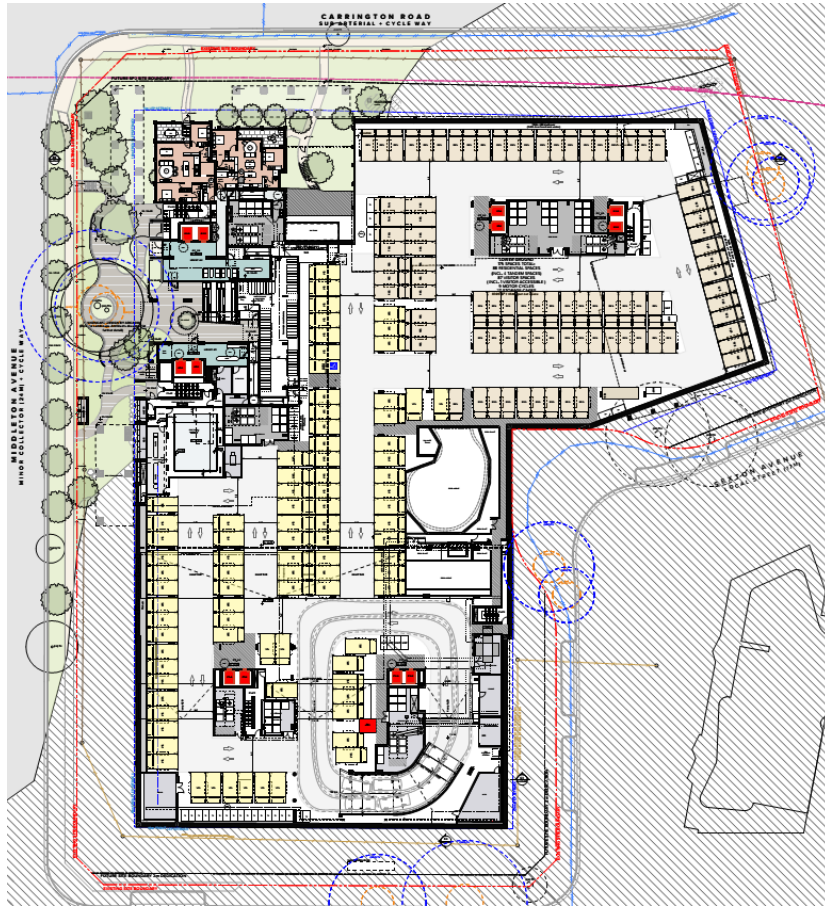

Lower Ground

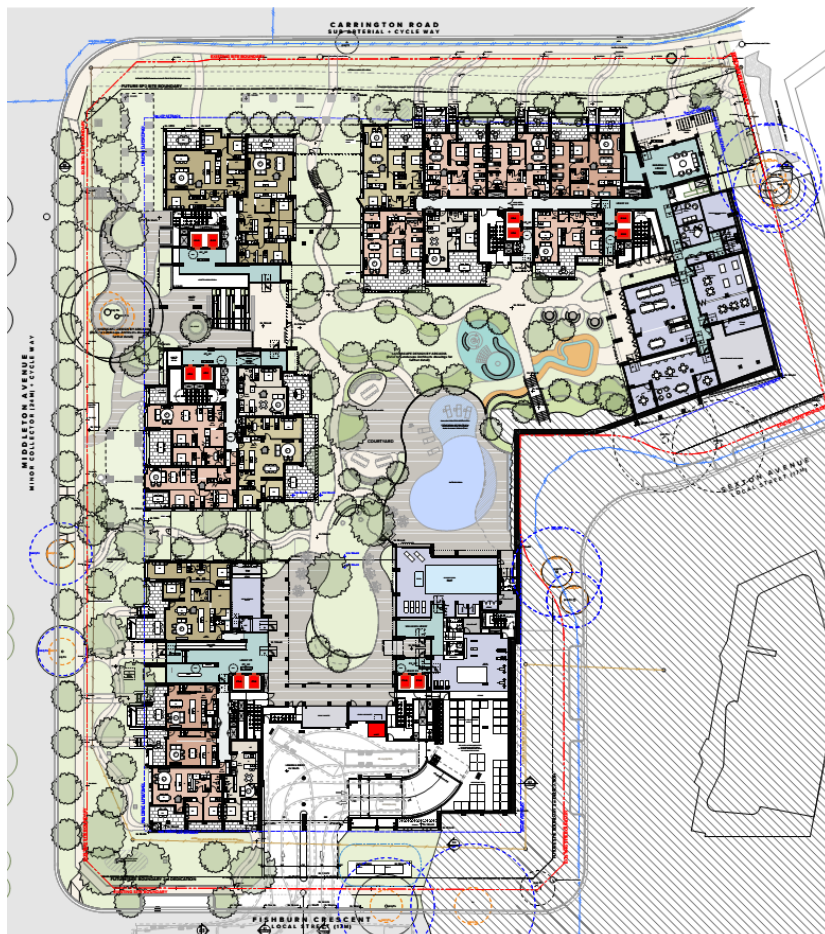

Ground Floor



Upper Ground



Level 1



Levels 2



Level 3



Level 4



Level 5



Level 6



Level 7



Level 8



Level 9



Level 10



Level 11

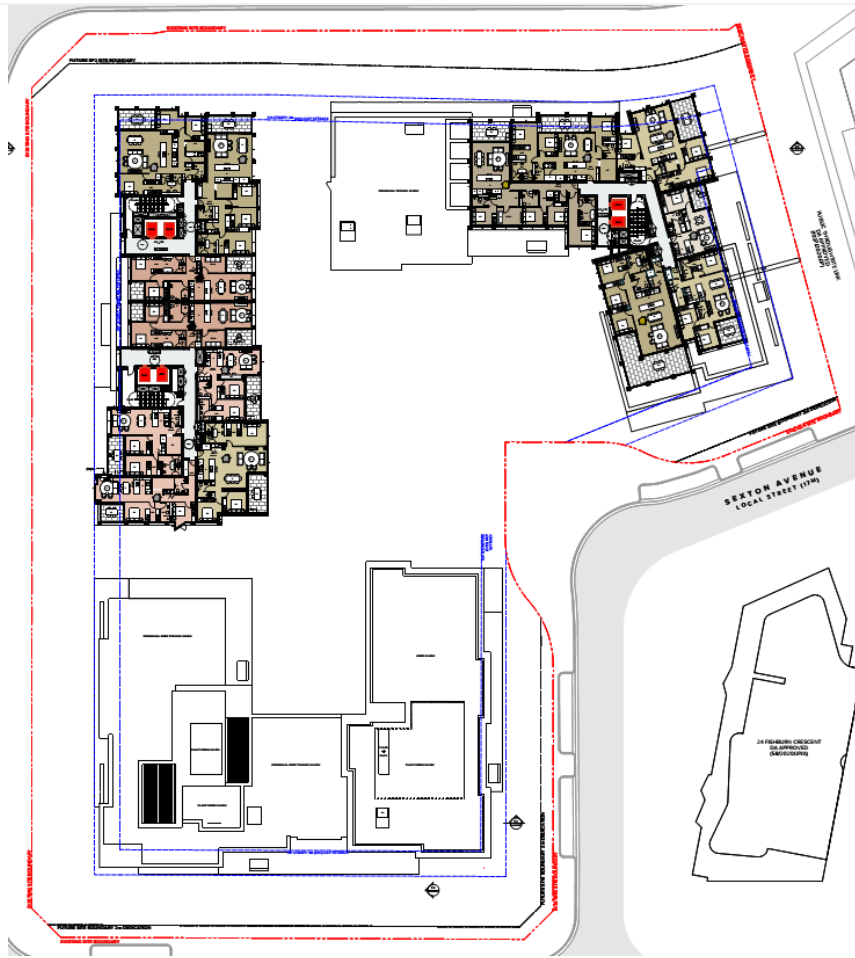

Level 12



Level 13

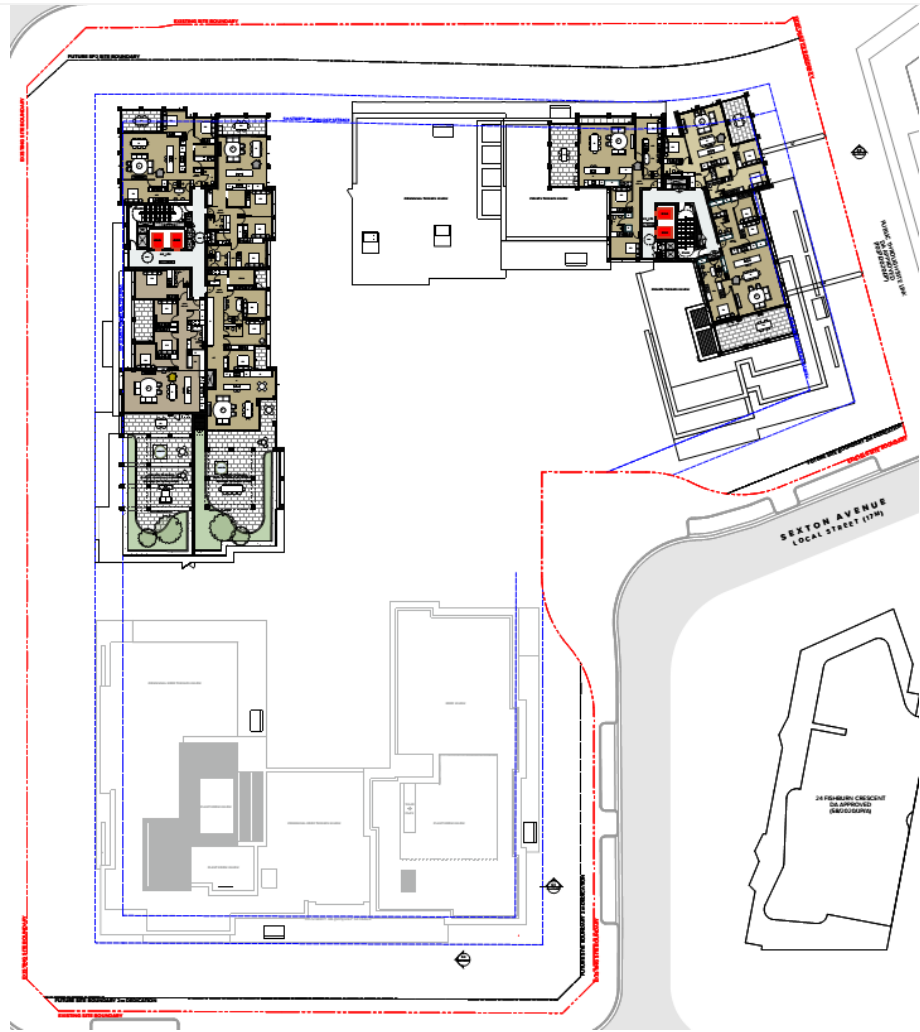

Level 14



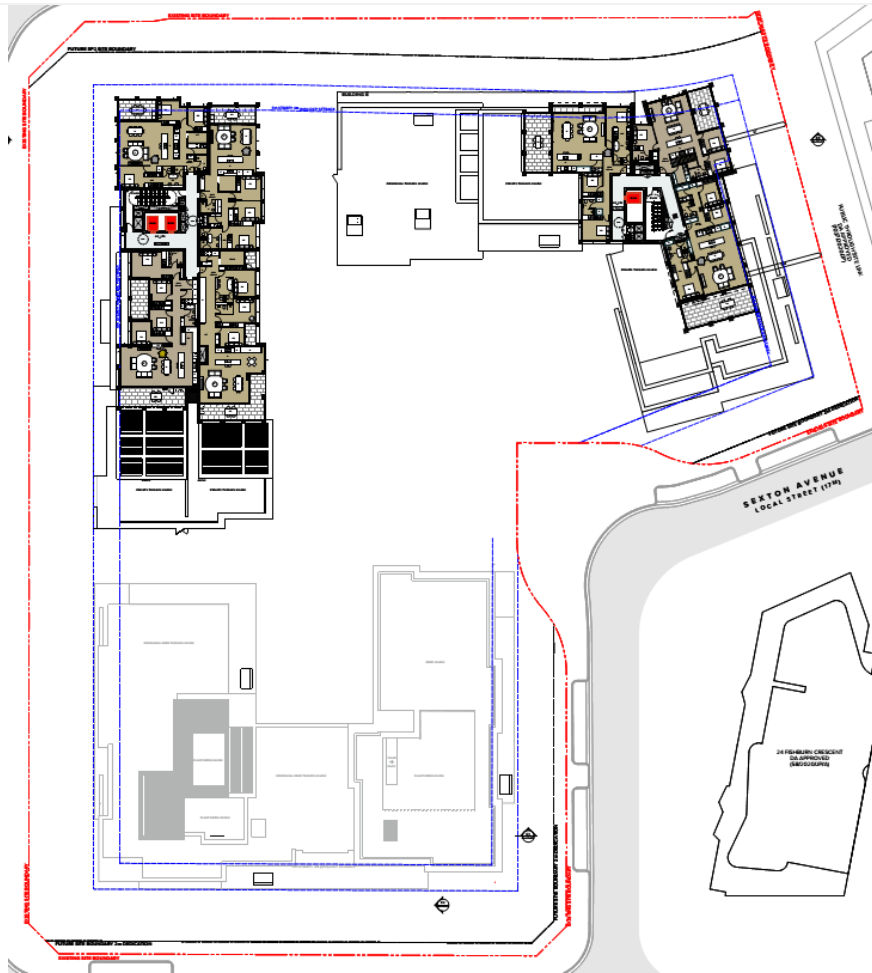

Level 15

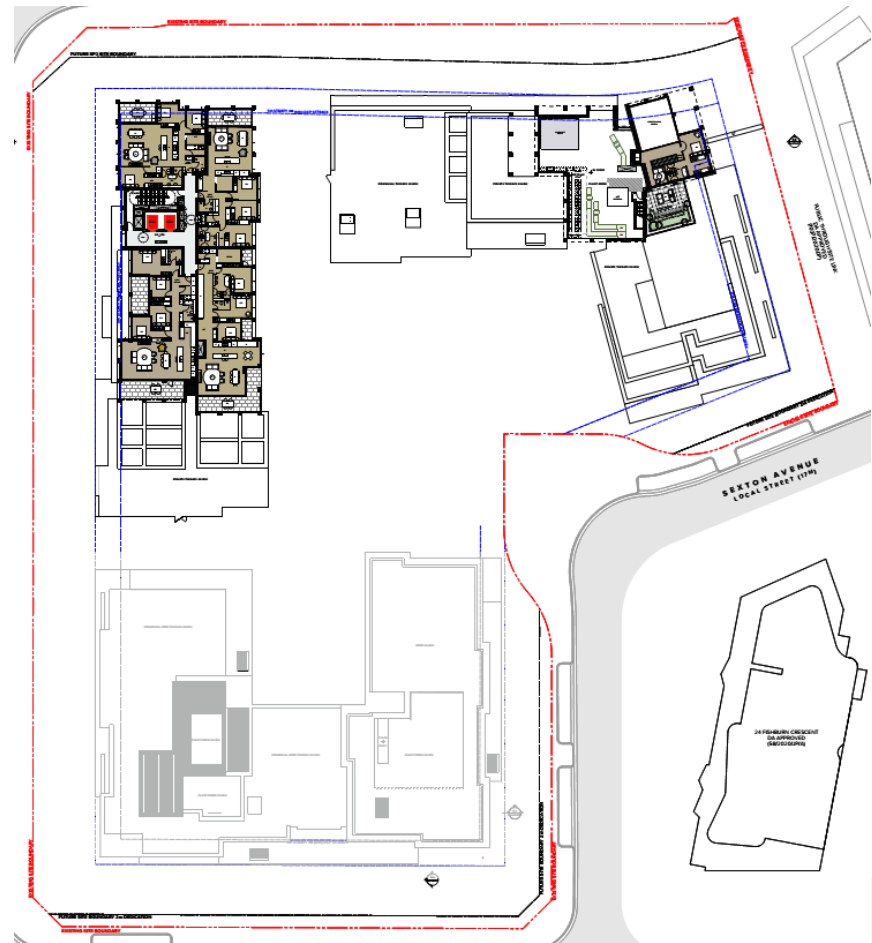

Level 16

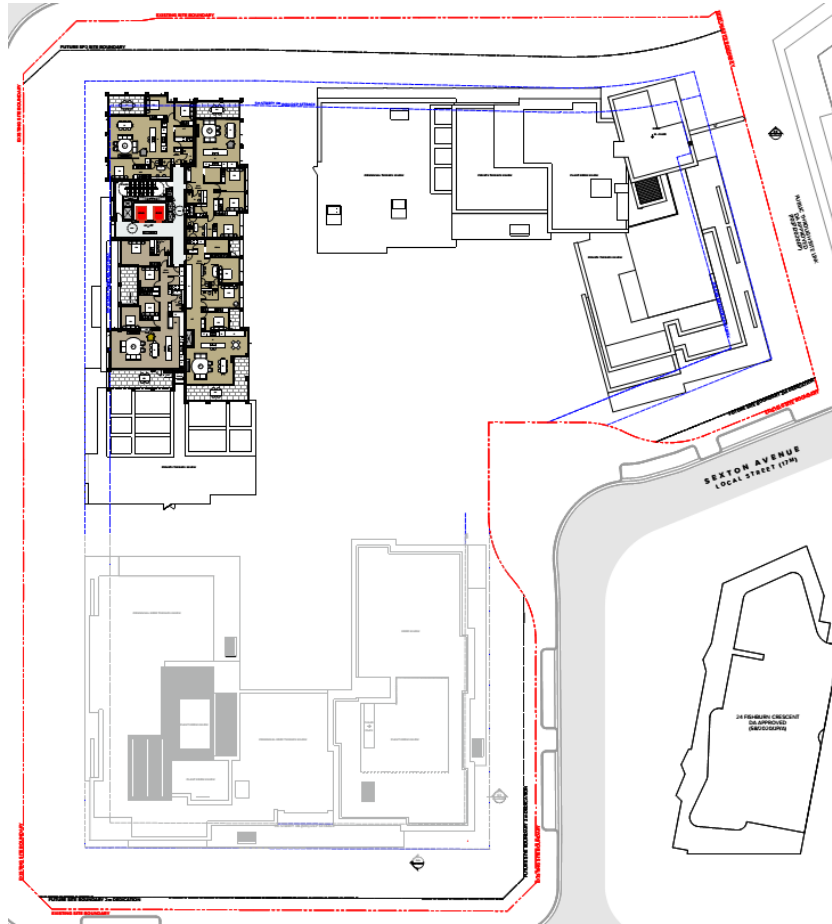

Level 17

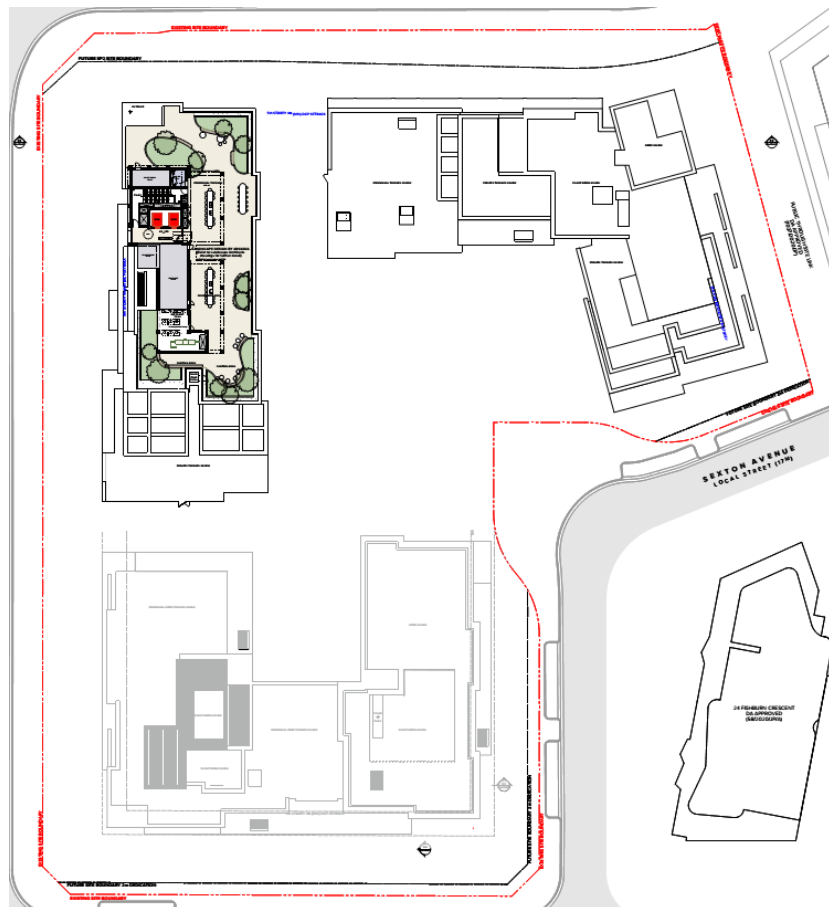

Level 18

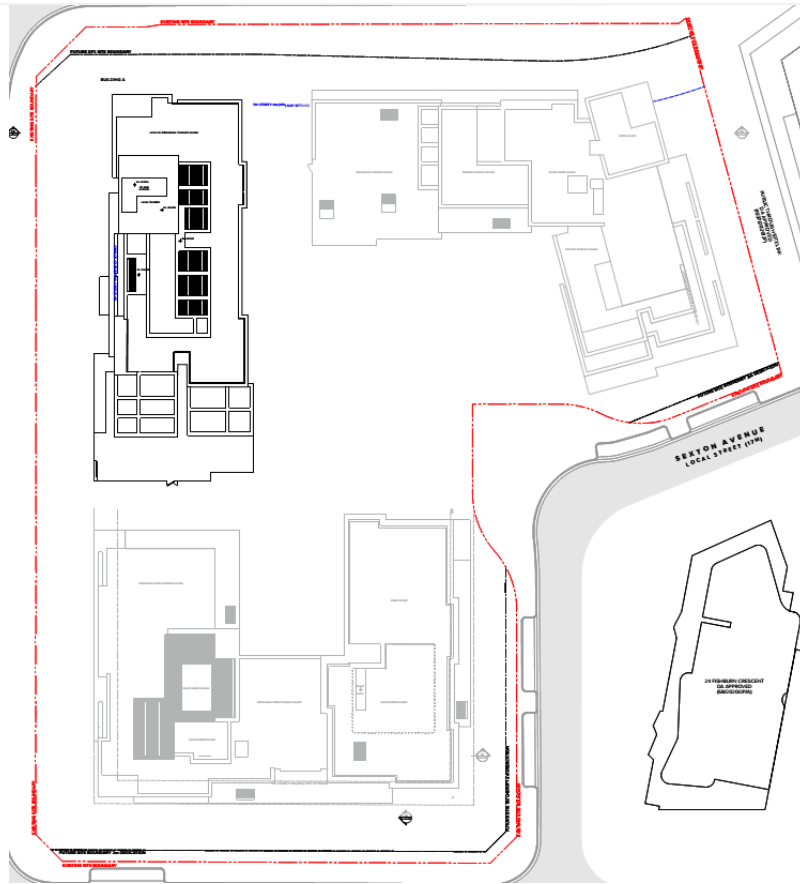

Roof Level

Att. 01 Floor Plans prepared by "TURNER" Issue No. DA.01 dated 12/09/2025

AS 1428.1 – Additional Requirements

The additional requirements set below to be read in full	ADR	N/A	C
<p>1. Access ways:</p> <ul style="list-style-type: none"> All access ways must have a minimum width of 1m clear and a vertical clearance of at least 2m. <p>Reference: Figure 30 Notes: See Att. 01 – can be compliant at the CC stage</p>	<input type="checkbox"/>	<input type="checkbox"/>	✓
<p>2. Doorway general requirements:</p> <ul style="list-style-type: none"> All doorways are to be in accordance with AS1428.1. Reference: Figure 29, Figure 29(A), Figure 29(B) Door thresholds are to be level or they can incorporate a threshold ramp as per AS1428.1 Reference: Figure 32 Distance between successive doorways in airlocks to be 1450mm which is measured when the door is in an open position in case of swinging doors Reference: Figure 31 Glazed viewing panels in doors shall conform to AS 1288. <ul style="list-style-type: none"> The lower edge of the glazing should not be more than 1000 mm above the plane of the finished floor. The upper edge of the glazing should be not less than 1600 mm above the plane of the finished floor. In width, the glazing should extend to within not more than 200 mm from the latch edge of the door and be not less than 150 mm wide. Reference: Figure 38 <p>Notes: See Att. 01 – can be compliant at the CC stage</p>	<input type="checkbox"/> <input type="checkbox"/> <input type="checkbox"/>	<input type="checkbox"/> <input type="checkbox"/> <input type="checkbox"/>	✓ ✓ ✓
<p>3. Door hardware:</p> <ul style="list-style-type: none"> Door hardware including door handles, door closers, snibs (in accessible toilets) are required to be as per the requirements in AS1428.1 <p>Reference: Figure 33 Notes: See Att. 01 – can be compliant at the CC stage</p>	<input type="checkbox"/>	<input type="checkbox"/>	✓
<p>4. Luminance contrast requirements for Doors:</p> <ul style="list-style-type: none"> All doorways are to have a minimum luminance contrast of 30% and a minimum width of 50mm provided as per AS1428.1 between any option of the following options: <ul style="list-style-type: none"> Door leaf and door jamb – min. 50mm or; Architrave “min. 50mm” and wall or; Door leaf and architrave – min. 50mm or; Door jamb “min. 50mm” and adjacent wall or; Door leaf and adjacent wall <p>Notes: See Att. 01 – can be compliant at the CC stage</p>	<input type="checkbox"/>	<input type="checkbox"/>	✓

<p>5. Floor Surfaces:</p> <ul style="list-style-type: none"> • Use slip resistant surfaces. The texture of the surface shall be traversable by people who use a wheelchair and those with an ambulant or sensory disability. <ul style="list-style-type: none"> - Refer to • Abutment of surfaces shall have a smooth transition. Construction specifications are to be as per AS1428.1. Reference: Figure 34, Figure 35 • Any grates along the path must be as per AS1428.1 Reference: Figure 36 <p>Notes: See Att. 01 – can be compliant at the CC stage</p>	<input type="checkbox"/>	<input type="checkbox"/>	<input checked="" type="checkbox"/>
<p>6. Switches and Outlets:</p> <ul style="list-style-type: none"> • All switches and controls on an accessible path of travel, other than general purpose outlets, shall be located not less than 900 mm nor more than 1100 mm above the plane of the finished floor and not less than 500 mm from internal corners. • GPOs are to be located between 600-1100mm above FFL and a minimum of 500mm from any internal corners. • Rocker action/toggle switches to be provided with a minimum size of 30mmx30mm • Push pad switches if used have a minimum dimension of 25mm diameter • All switches in accessible sole occupancy units or sanitary facilities are to be located as per AS1428.1 <p>Reference: Figure 37 Notes: See Att. 01 – can be compliant at the CC stage</p>	<input type="checkbox"/>	<input type="checkbox"/>	<input checked="" type="checkbox"/>



Additional Requirements – References

The references below to be read as set and referenced in each section of Additional Requirements

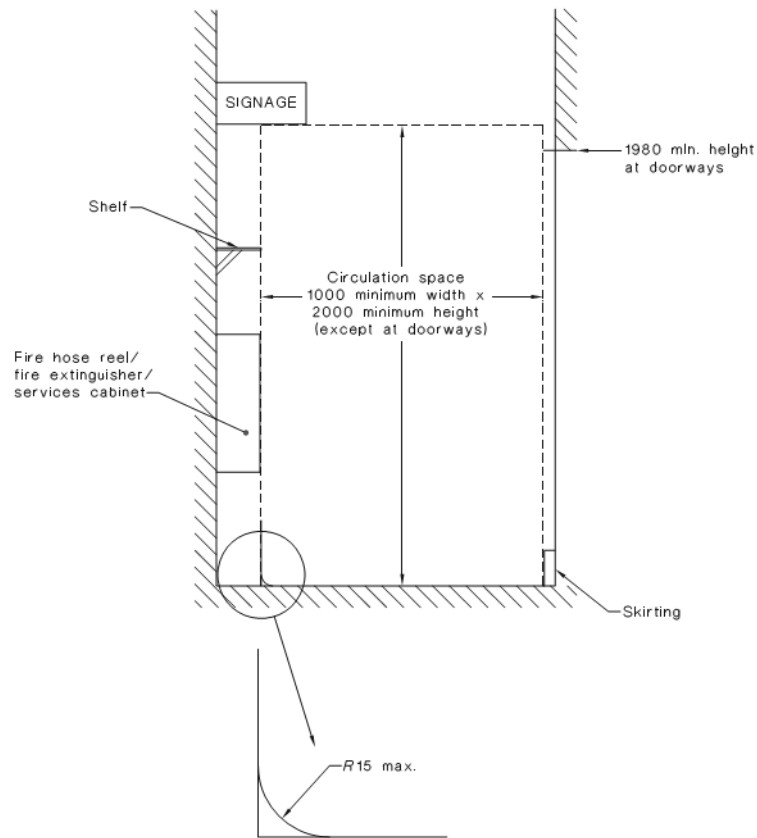
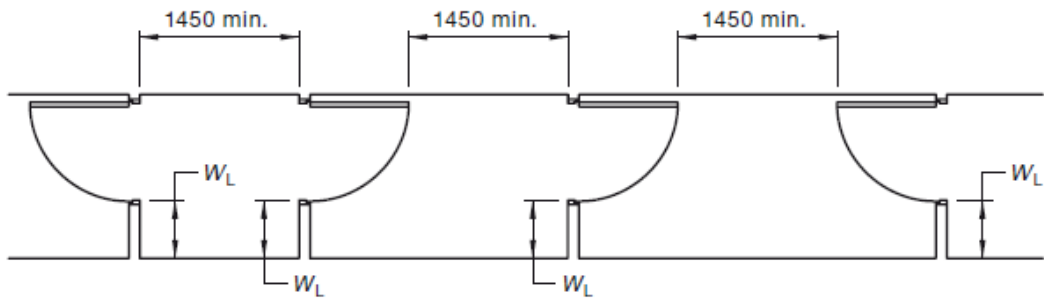

Figure 30

SAI Global Ltd License 1704-c045-2



(a) Continuous accessible path of travel

DIMENSIONS IN MILLIMETRES

Figure 31

SAI Global Ltd License 1704-c045-2

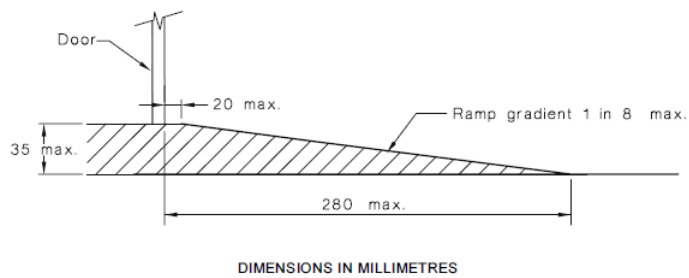
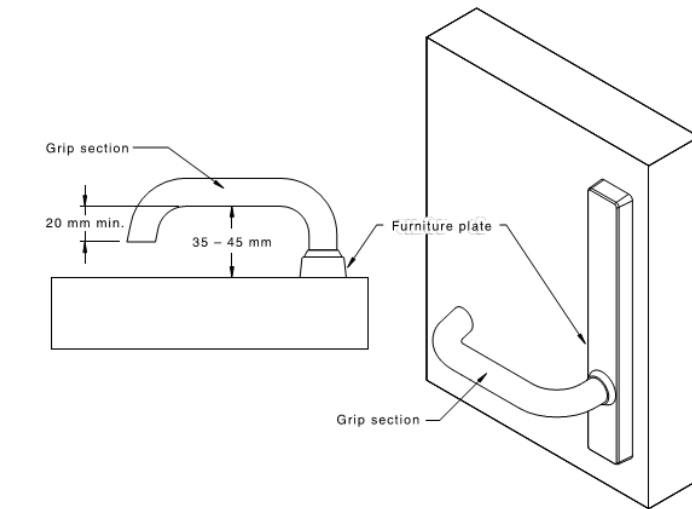
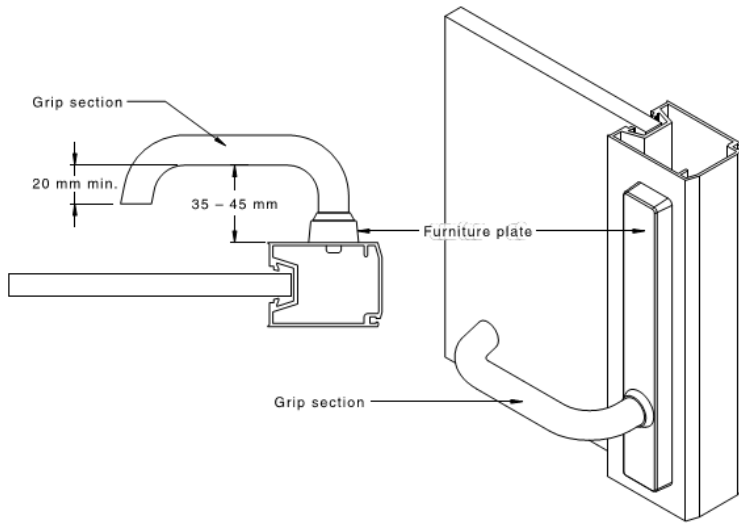
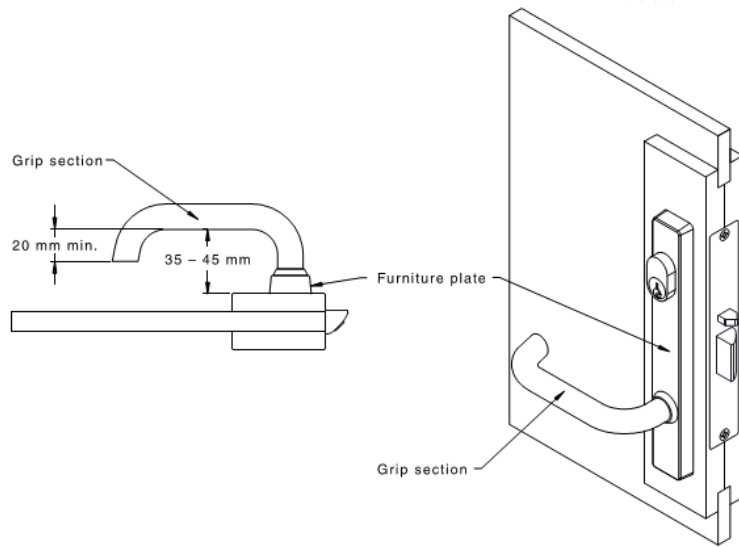
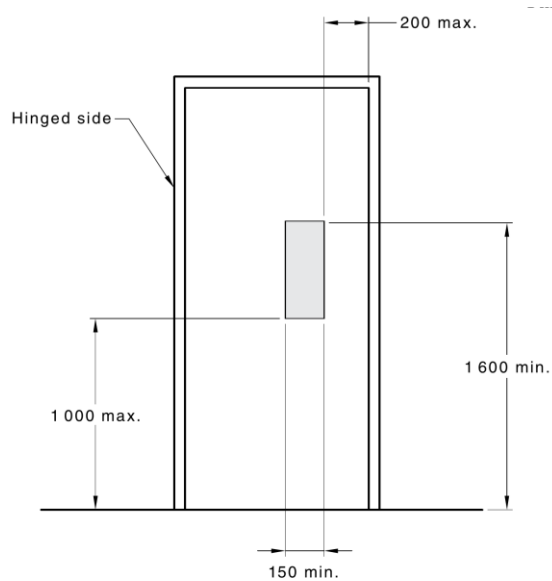
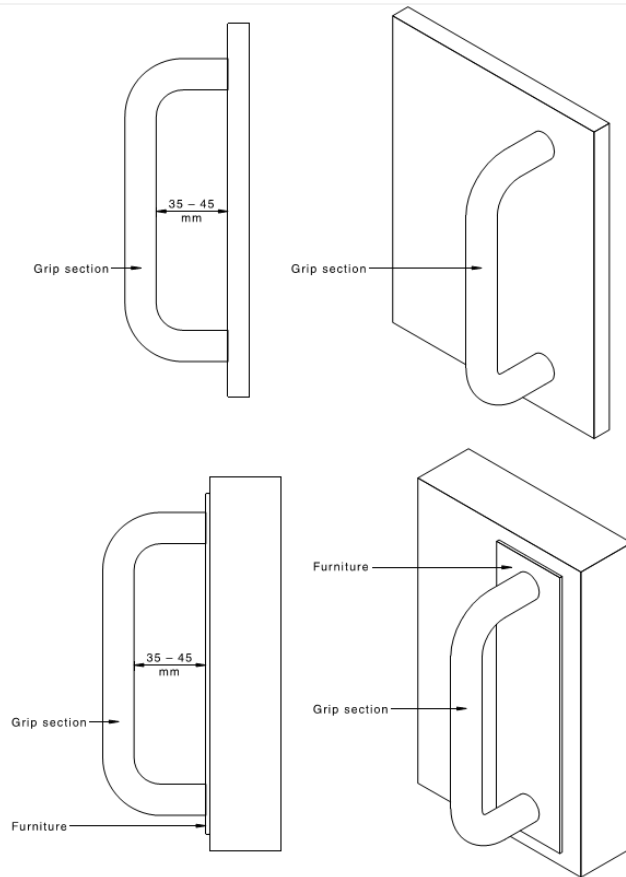

Figure 32

SAI Global Ltd License 1704-c045-2





(a) Minimum zones for glazed viewing panel

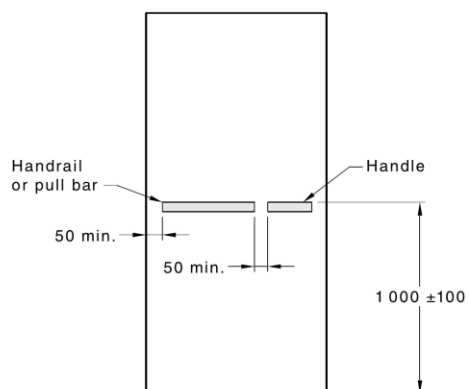

Location

Except in early childhood centres, swimming pool barriers or similar situations where the location of the opening and locking controls is prescribed by the relevant statutory authority, the location of the controls for doors and gates shall be above a level surface and as follows:

- (a)** Controls that need to be grasped or turned or pushed or pulled to operate a door shall be not less than 900 mm and not more than 1100 mm above the plane of the finished floor, as shown in the Figure above and not less than 500 mm from an internal corner except as specified in AS 1735.12.
- (b)** Controls that only need to be pushed in the direction of travel, such as panic bars on egress routes, shall be not less than 900 mm, and not greater than 1200 mm above the plane of the finished floor.
- (c)** Controls that only need to be touched shall be not less than 900 mm, and not greater than 1250 mm above the plane of the finished floor, and not less than 500 mm from an internal corner except as specified in AS 1735.12.
- (d)** Handles on sliding doors shall be not less than 60 mm from the door jamb or doorstop when in the open or closed position, as shown in Figure 29(B).
- (e)** Manual controls to power-operated doors shall be located on the continuous accessible path of travel no closer than 500 mm from an internal corner and between 500 mm to 1 000 mm from the arc of the hinged door leaf or clear of a surface-mounted sliding door in the open position.

Figure 33

SAI Global Ltd License 1704-c045-2

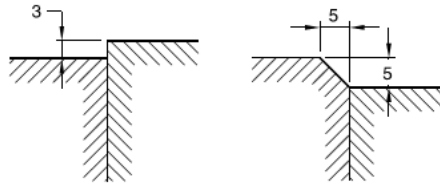

(a) Change in level

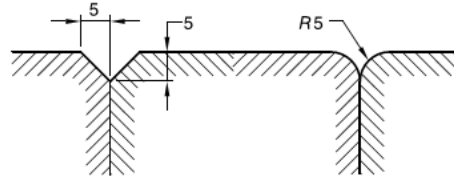

Continuous paving units — flush-jointed with level surfaces

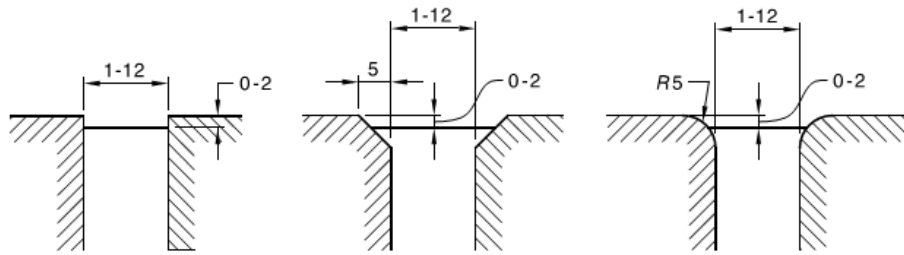

(a) Continuous paving units — Level surface

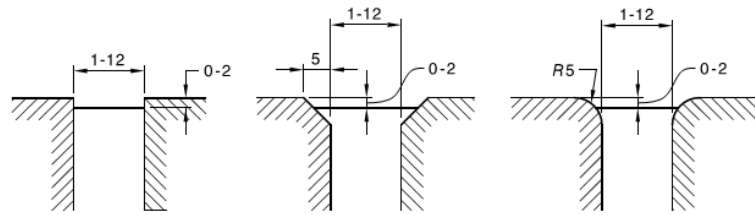

(a) Continuous paving units — Level surface

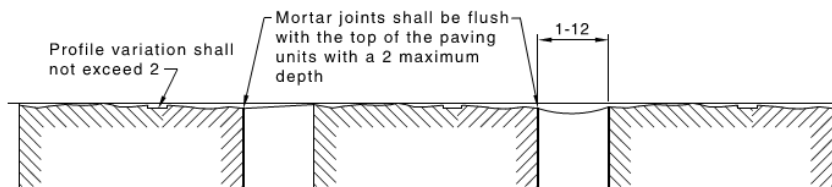

(b) Continuous paving units — Irregular surfaces

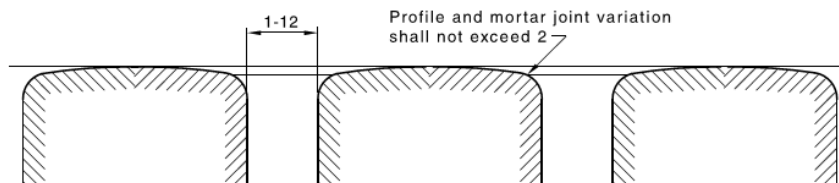

(c) Continuous paving units — Domed surfaces

Figure 34

SAI Global Ltd License 1704-c045-2

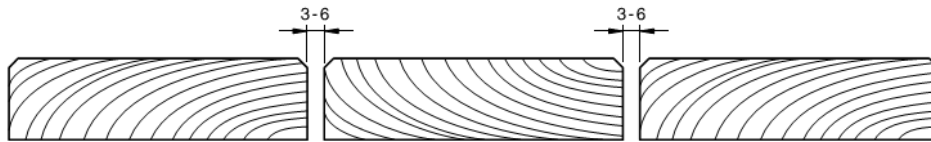

(a) Gap spacing for continuous timber and composite decking
 * Gaps may be increased to 10 mm in high rainfall areas for exposed installations and boards exceeding 150 mm width

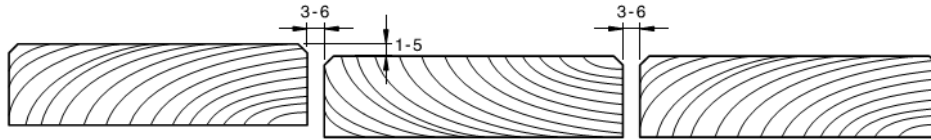

(b) Single incidence of change in level on timber and composite decking

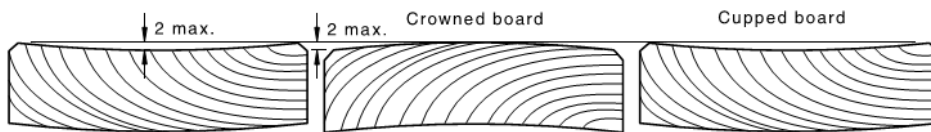

(c) Uneven surface tolerances for continuous timber and composite decking

Figure 35

SAI Global Ltd License 1704-c045-2

Grates

Grates in paths of travel shall be in accordance with the following:

- (a) Circular openings shall be not greater than 13 mm in diameter.
- (b) Slotted openings shall be not greater than 13 mm wide and not greater than 150 mm long and be oriented so that the long dimension is transverse to the dominant direction of travel.
- (c) Linear openings shall be oriented so that the longer dimension is transverse to the dominant direction of travel, except where linear openings are less than 8 mm wide, Where linear openings are less than 8 mm wide, orientation is optional.

Figure 36

SAI Global Ltd License 1704-c045-2

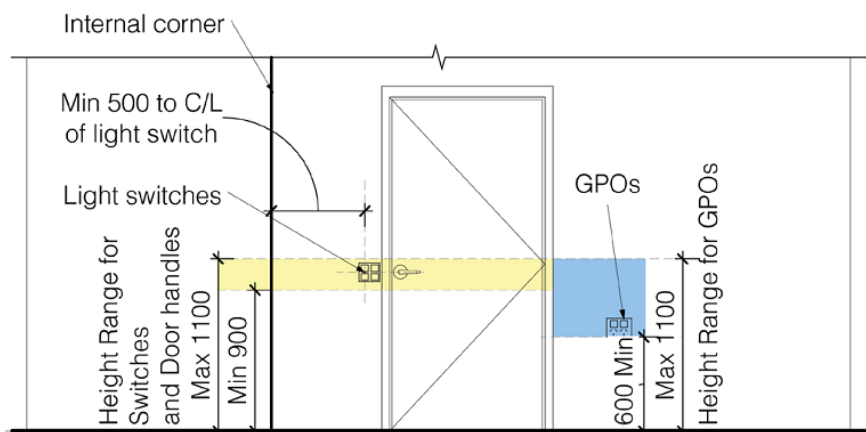

Figure 37

SAI Global Ltd License 1704-c045-2

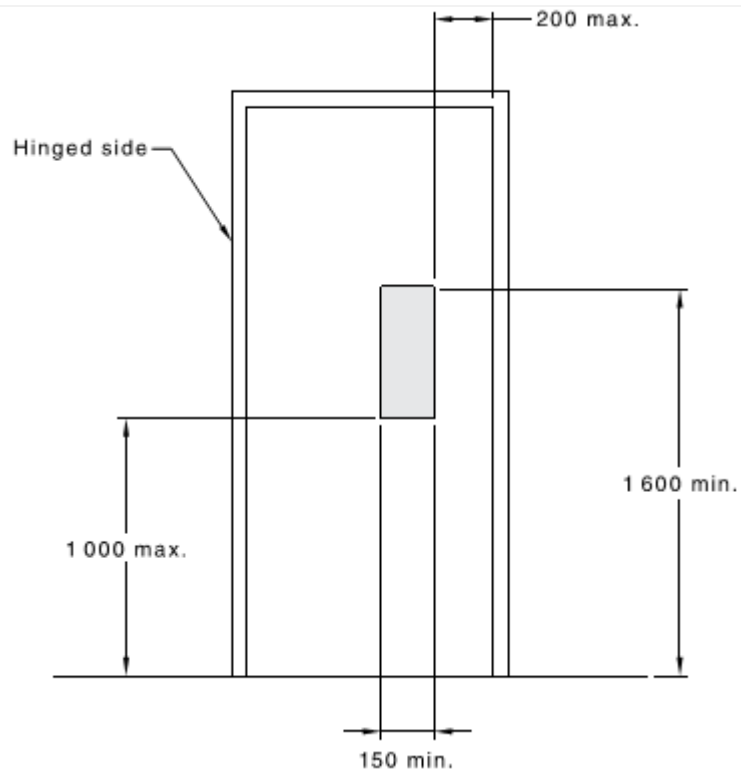

Figure 38

SAI Global Ltd License 1704-c045-2



Part E3 – Lift Installations

E3D3 Stretcher facility lifts	ADR	N/A	C
<p>(a) a stretcher facility in accordance with (b) must be provided;</p> <p>I. In at least one emergency lift required by E3D5</p> <p>II. When an emergency lift is not required, if passenger lifts are installed to serve any storey above an effective height of 12m, in at least one of those lifts to serve each floor served by the lifts</p> <p>Notes: Subject to BCA Consultant review and confirmation, can be compliant at the CC stage & as per manufacturers specifications.</p>	<input type="checkbox"/>	<input type="checkbox"/>	<input checked="" type="checkbox"/>
<p>(b) a stretcher facility must accommodate a raised stretcher providing a clear space not less than 600mm wide x 2000mm long x 1400mm high above the floor level</p> <p>Notes: Subject to BCA Consultant review and confirmation, can be compliant at the CC stage & as per manufacturers specifications.</p>	<input type="checkbox"/>	<input type="checkbox"/>	<input checked="" type="checkbox"/>
E3D7 Passenger lift types and their limitations	ADR	N/A	C
<p>(1) In an accessible building, every passenger lift must be one of the following lift types, subject to the limitations (if any) of each lift type:</p> <p>(a) There are no limitations on the use of electric passenger lifts, electrohydraulic passenger lifts or inclined lifts.</p> <p>A passenger lift referred to in (1) must not rely on a constant pressure device for its operation if the lift car is fully enclosed.</p> <p>Notes: Can be compliant at the CC stage & as per manufacturer specifications.</p>	<input type="checkbox"/>	<input type="checkbox"/>	<input checked="" type="checkbox"/>
E3D8 Accessible features required for passenger lifts	ADR	N/A	C
<p>Stairway platform lift; Must Not –</p> <p>(a) be used to serve a space in a building accommodating more than 100 persons calculated according to D2D18</p> <p>(b) be used in a high traffic public use area such as a theatre, cinema, auditorium, transport interchange, shopping centre or the like</p> <p>(c) be used where it is possible to install another type of passenger lift</p> <p>(d) connect more than 2 storeys</p> <p>(e) where more than 1 stairway lift is installed, serve more than 2 consecutive storeys</p> <p>(f) when in the folded position, encroach on the minimum width of stairway required by D2D8 to D2D11</p>	<input type="checkbox"/>	<input checked="" type="checkbox"/>	<input type="checkbox"/>
<p>Low-rise platform lift;</p> <p>Must not travel more than 1000mm</p>	<input type="checkbox"/>	<input checked="" type="checkbox"/>	<input type="checkbox"/>
<p>Low-rise, low-speed constant pressure lift; Must not –</p> <p>(a) for an enclosed type travel more than 4m</p> <p>(b) for an unenclosed type, travel more than 2m</p> <p>(c) be used in high traffic public use areas in buildings such as a theatre, cinema, auditorium, transport interchange, shopping complex or the like</p>	<input type="checkbox"/>	<input checked="" type="checkbox"/>	<input type="checkbox"/>
<p>Small sized, low-speed automatic lift;</p> <p>Must not travel more than 12m</p>	<input type="checkbox"/>	<input checked="" type="checkbox"/>	<input type="checkbox"/>
E3D8 Accessible features required for passenger lifts	ADR	N/A	C
<p>All lifts except “stair platform lift” and “low-rise platform lift” have handrails complying with the provisions for a mandatory handrail in AS1735.12</p> <p>Notes: Can be compliant at the CC stage & as per manufacturer specifications.</p>	<input type="checkbox"/>	<input type="checkbox"/>	<input checked="" type="checkbox"/>
<p>All lifts which travel more than 12m to have lift floor dimension of not less than 1400mm wide x 1600mm deep</p> <p>Notes: Can be compliant at the CC stage & as per manufacturer specifications.</p>	<input type="checkbox"/>	<input type="checkbox"/>	<input checked="" type="checkbox"/>

All lifts which travel not more than 12m “excluding stairway platform lift” to have lift floor dimension of not less than 1100mm wide x 1400mm deep	<input type="checkbox"/>	<input checked="" type="checkbox"/>	<input type="checkbox"/>
Floor dimension for a stairway platform lift of not less than 810 mm wide x 1200 mm deep	<input type="checkbox"/>	<input checked="" type="checkbox"/>	<input type="checkbox"/>
Minimum door opening complying with AS 1735.12 for All lifts except a stairway platform lift Notes: Can be compliant at the CC stage & as per manufacturer specifications.	<input type="checkbox"/>	<input type="checkbox"/>	<input checked="" type="checkbox"/>
Passenger protection system complying with AS 1735.12 for all lifts with a power operated door Notes: Can be compliant at the CC stage & as per manufacturer specifications.	<input type="checkbox"/>	<input type="checkbox"/>	<input checked="" type="checkbox"/>
Lift landing doors at the upper landing to be provided for All lifts except “stairway platform lift” Notes: Can be compliant at the CC stage & as per manufacturer specifications.	<input type="checkbox"/>	<input type="checkbox"/>	<input checked="" type="checkbox"/>
Lift car and landing control buttons to comply with AS 1735.12 for All lifts except a “stairway platform lift” and “low-rise platform lift” Notes: Can be compliant at the CC stage & as per manufacturer specifications.	<input type="checkbox"/>	<input type="checkbox"/>	<input checked="" type="checkbox"/>
Lighting in accordance with AS 1735.12 for all enclosed lift cars Notes: Can be compliant at the CC stage & as per manufacturer specifications.	<input type="checkbox"/>	<input type="checkbox"/>	<input checked="" type="checkbox"/>
All lifts servicing more than 2 levels; (a) Automatic audible information within the lift car to identify the level each time the car stops, and (b) Audible and visual indication at each lift landing to indicate the arrival of the lift car, and (c) Audible information and audible indication required by (z) and (b) is to be provided in a range of between 20-80 dB(A) at a maximum frequency of 1500 Hz Notes: Can be compliant at the CC stage & as per manufacturer specifications.	<input type="checkbox"/>	<input type="checkbox"/>	<input checked="" type="checkbox"/>
All lifts except “stairway platform lift” to have an emergency hands-free communication, including a button that alerts a call centre of a problem and a light to signal that the call has been received Notes: Can be compliant at the CC stage & as per manufacturer specifications.	<input type="checkbox"/>	<input type="checkbox"/>	<input checked="" type="checkbox"/>



Part F4 – Access For People With Disability

F4D5 Accessible sanitary facilities	ADR	N/A	C
<p>(a) accessible unisex sanitary compartments must be provided in accessible parts of the building:</p> <p>Class 2; Where sanitary compartments are provided in common area, not less than 1</p> <p>Class 7; Where building class requires closet pans as per the BCA—1 on every storey containing sanitary compartments; and where a storey has more than 1 bank of sanitary compartments containing male and female sanitary compartments, at not less than 50% of those banks.</p> <p>Reference: Figure 38, Figure 39, Figure 40, Figure 41, Figure 42, Figure 43, Figure 44, Figure 45</p> <p>Notes: See Att. 01 – ‘LH’ and ‘RH’ accessible WC’s have been provided and can be compliant at the CC stage as follows and can be compliant at the CC stage in accordance with AS1428.1-2009:</p> <ul style="list-style-type: none"> - 1x ‘LH’ accessible WC with an accessible shower has been provided to the outdoor pool - 1x ‘LH’ & 1x ‘RH’ accessible WCs with accessible showers have been provided to the wellness lobby and gym area - 1x ‘LH’ & 1x ‘RH’ accessible WCs have been provided at the communal entertainment area next to lobby “B” building on the Ground Level - 1x ‘LH’ accessible WC has been provided to the yoga studio area - 1x ‘LH’ accessible WC has been provided to the communal terrace at L10 - 1x ‘RH’ accessible WC has been provided to the communal terrace at L18 	<input type="checkbox"/> <input type="checkbox"/>	<input type="checkbox"/> ✓	<input checked="" type="checkbox"/> <input type="checkbox"/>
<p>(b) accessible unisex showers must be provided in accessible parts of the building:</p> <p>Class 2; Where showers are provided in common area, not less than 1</p> <p>Class 7 — <i>except for within a ward area of a Class 9a health-care building;</i> Where F4D4 requires 1 or more showers, not less than 1 for every 10 showers or part thereof.</p> <p>Notes: See Att. 01 – 3 accessible showers have been provided as follows and can be compliant at the CC stage in accordance with AS1428.1-2009</p> <ul style="list-style-type: none"> - 1x ‘LH’ accessible WC with an accessible shower has been provided to the outdoor pool - 1x ‘LH’ & 1x ‘RH’ accessible WCs with accessible showers have been provided to the wellness lobby and gym area 	<input type="checkbox"/> <input type="checkbox"/>	<input type="checkbox"/> ✓	<input checked="" type="checkbox"/> <input type="checkbox"/>
<p>(c) at each bank of toilets in addition to an accessible unisex sanitary compartment, a sanitary compartment suitable for a person with an ambulant disability must be provided in accordance with 1428.1 for male and females</p>	<input type="checkbox"/>	<input checked="" type="checkbox"/>	<input type="checkbox"/>
<p>(d) an accessible unisex compartment must contain a closet pan, washbasin, shelf or bench top and adequate means of disposal of sanitary products</p> <p>Reference: Figure 43</p> <p>Notes: See Att. 01 – can be compliant at the CC stage in accordance with AS1428.1-2009</p>	<input type="checkbox"/>	<input type="checkbox"/>	<input checked="" type="checkbox"/>
<p>(e) the circulation space, fixture and fittings must comply with the requirements of AS 1428.1</p> <p>Reference: Figure 39, Figure 40, Figure 41, Figure 42, Figure 43, Figure 44, Figure 45</p> <p>Notes: See Att. 01 – can be compliant at the CC stage in accordance with AS1428.1-2009</p>	<input type="checkbox"/>	<input type="checkbox"/>	<input checked="" type="checkbox"/>

<p>(f) an accessible unisex sanitary must be located to that it can be entered without crossing an area reserved for one sex only</p> <p>Notes: See Att. 01 – can be compliant at the CC stage in accordance with AS1428.1-2009</p>	<input type="checkbox"/>	<input type="checkbox"/>	✓
<p>(g) where two or more of each type of accessible unisex sanitary facility are provided, the number of left and right-handed facilities must be provided as evenly as possible</p> <p>Notes: See Att. 01 – ‘LH’ and ‘RH’ accessible WCs have been provided and can be compliant at CC stage in accordance with AS1428.1-2009</p> <ul style="list-style-type: none"> - 1x ‘LH’ accessible WC with an accessible shower has been provided to the outdoor pool - 1x ‘LH’ & 1x ‘RH’ accessible WCs with accessible showers have been provided to the wellness lobby and gym area - 1x ‘LH’ accessible WC has been provided to the yoga studio area - 1x ‘LH’ accessible WC has been provided to the communal terrace at L10 - 1x ‘RH’ accessible WC has been provided to the communal terrace at L18 	<input type="checkbox"/>	<input type="checkbox"/>	✓
<p>(h) where male and female sanitary facility are provided at a separate location of female sanitary facilities, accessible unisex sanitary facility are only required at one of those locations.</p>	<input type="checkbox"/>	✓	<input type="checkbox"/>
<p>(i) an accessible unisex sanitary or an accessible unisex shower need not be provided on a storey or level that is not required by D4D4(f) to be provided with a passenger lift or ramp complying with AS 1428.1</p>	<input type="checkbox"/>	✓	<input type="checkbox"/>
<p>(j) Baby change tables cannot encroach into the circulation space. Maximum height to be 820mm with 720mm underneath when in an open position.</p>	<input type="checkbox"/>	✓	<input type="checkbox"/>



Part F4 – References

The references below to be read as set and referenced in each section of part F4



Figure 38

SAI Global Ltd License 1704-c045-2

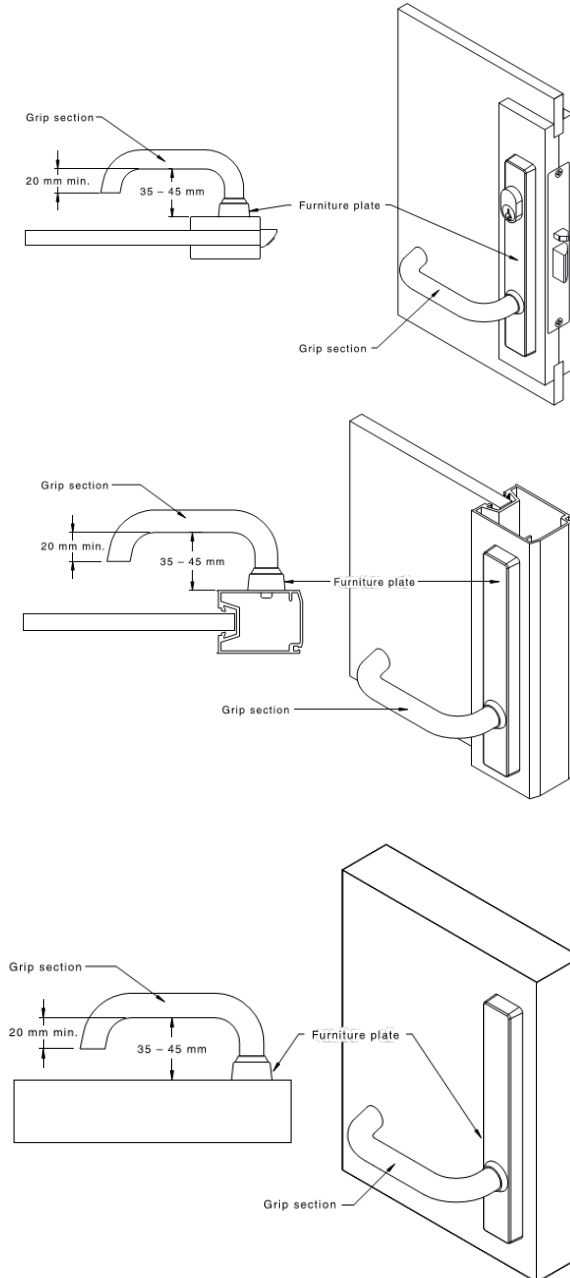
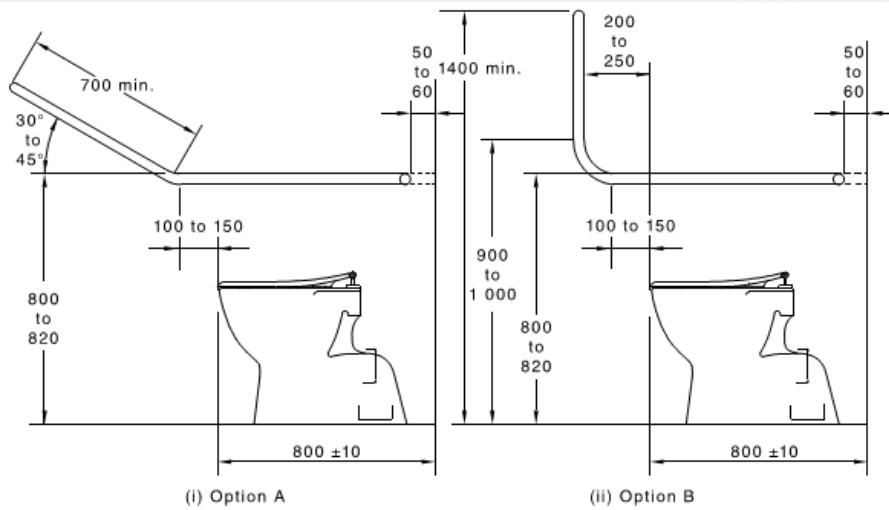
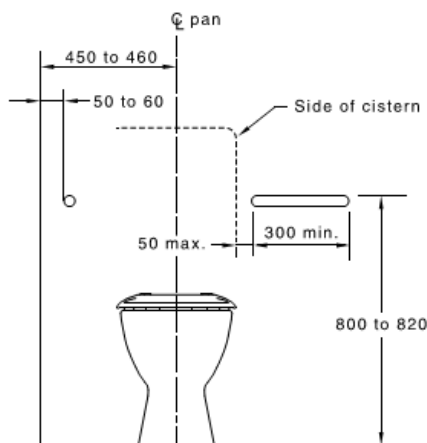

Figure 39

SAI Global Ltd License 1704-c045-2



(a) Side view showing optional systems for grabrail at sides of pan



(b) Grabrail at back of pan with surface-mounted cistern and sectional view of grabrail at side of pan

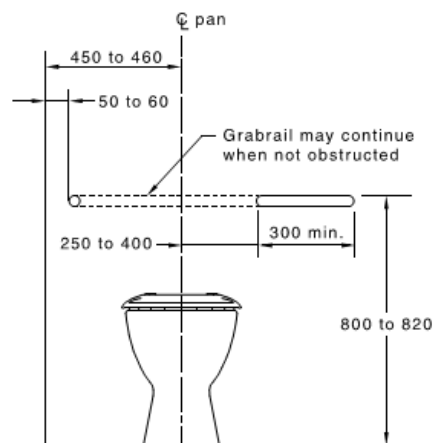

(c) Grabrail at back of pan with concealed or remote cistern and sectional view of grabrail at side of pan

Figure 40

SAI Global Ltd License 1704-c045-2

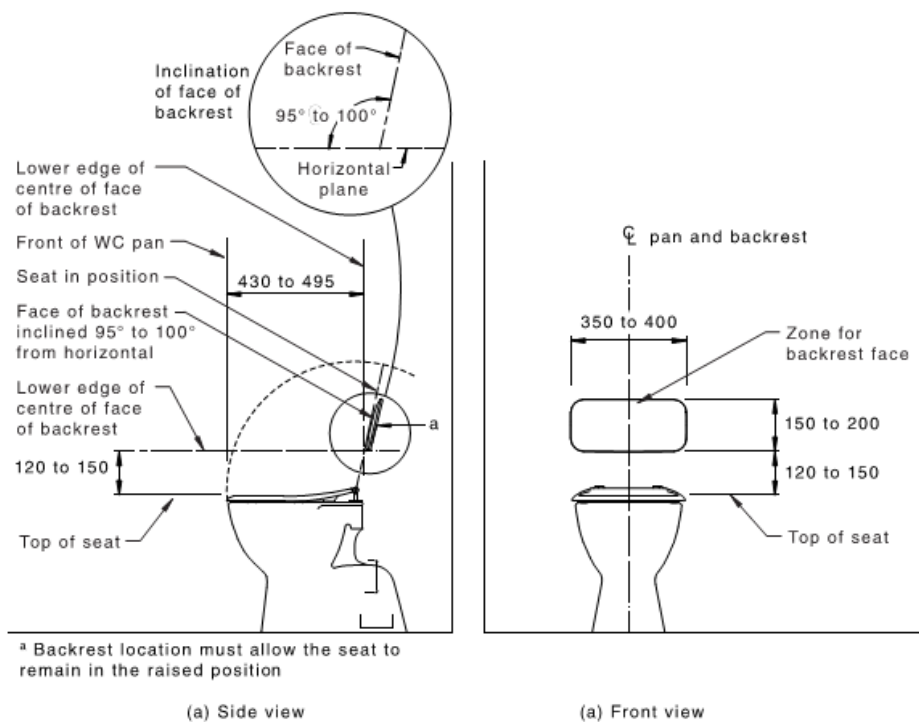
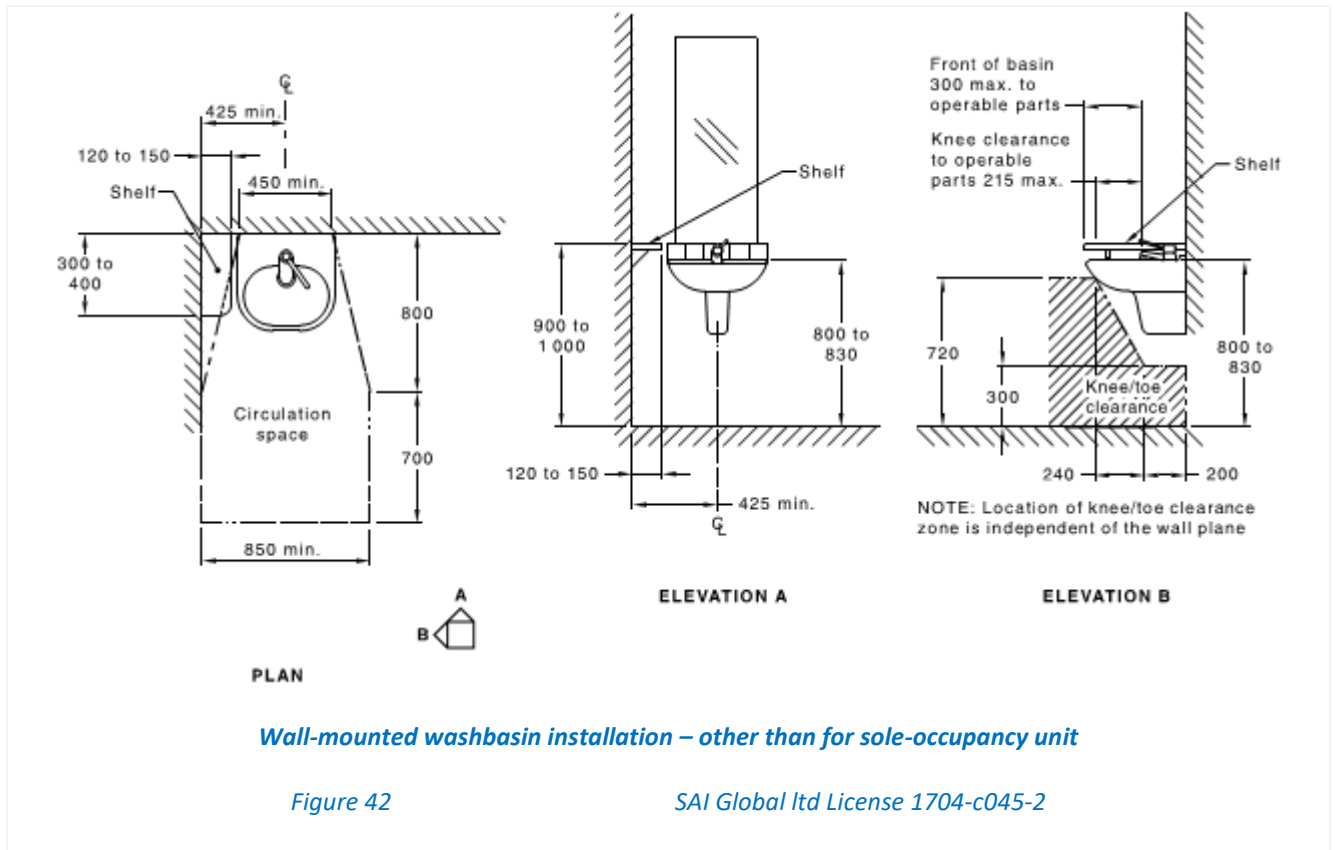

Figure 41

SAI Global Ltd License 1704-c045-2



Fixture and fittings within a sanitary facility

Mirrors

In all sanitary facilities, a mirror shall be provided and located either above or adjacent to the washbasin. Where located above the washbasin, the mirror shall extend from a height of not more than 900 mm to a height of not less than 1 850 mm above the plane of the finished floor. Where located adjacent to a washbasin, the mirror shall extend from a height of not more than 780 mm to a height of not less than 1 850 mm above the plane of the finished floor.

No mirror shall be less than 350 mm wide. All dimensions apply to the reflective surface of the mirror. The reflective surface shall be vertical.

In an accessible sole occupancy unit, a mirror shall be centred over the washbasin.

Shelves

Shelf space shall be provided adjacent to the washbasin in one of the following ways:

- (a) As a vanity top at a height of 800 mm to 830 mm and a minimum width of 120 mm and a minimum depth of 300 mm and a depth no greater than of the bowl plus its front and back flanges without encroaching into the circulation space of any other fixture.
- (b) As a separate fixture —
 - (i) within any circulation space at a height of 900 mm to 1000 mm with a width of 120 mm to 150 mm and length of 300 mm to 450 mm; and
 - (ii) external to all circulation spaces at a height of 790 mm to 1 000 mm with a minimum width of 120 mm and minimum length of 400 mm.

Soap dispensers, towel dispensers and similar fittings

Where provided, soap dispensers, towel dispensers, hand dryers and similar fittings shall be operable by one hand, and shall be installed with the height of their operative component or outlet not less than 900 mm and not more than 1 100 mm above the plane of the finished floor, and no closer than 500 mm from an internal corner.

Clothes-hanging devices

A clothes-hanging device shall be installed 1200 mm to 1350 mm above the plane of the finished floor and not less than 500 mm out from any internal corner.

Sanitary disposal unit

Where provided, the sanitary disposal unit shall be located as follows:

- (a) Portable unit as shown in Figure 44.
- (b) Recessed unit within 500 mm from the pan.

Switches and general purpose outlets

Where provided near the washbasin, switches and general purpose outlets shall be located in accordance with Figure 37 and as close to the shelf or worktop as practicable.

NOTE For requirements on general wiring rules refer to AS/NZS 3000.

Figure 43

SAI Global Ltd License 1704-c045-2

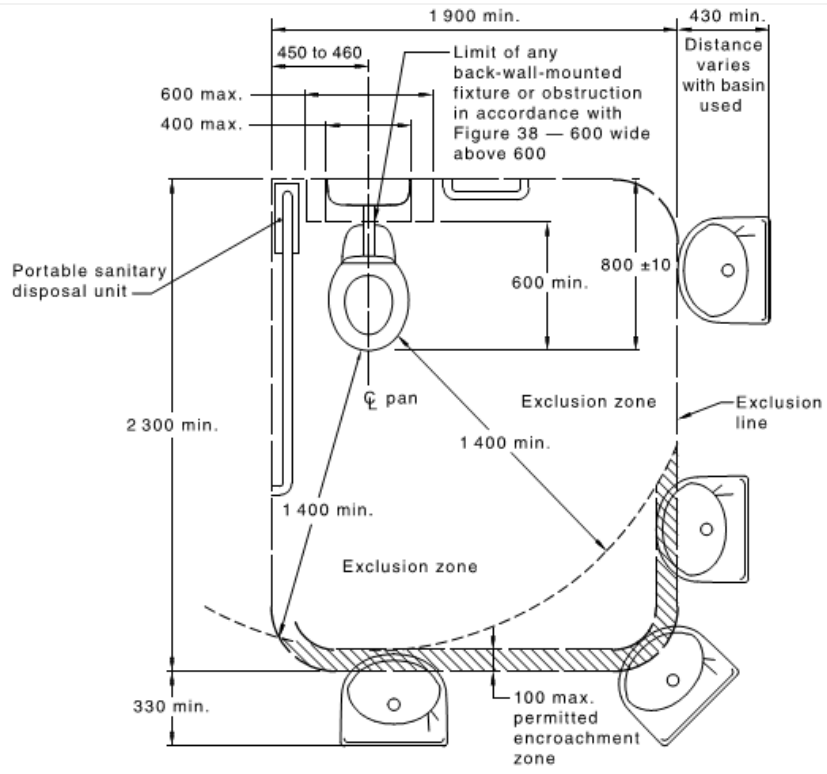
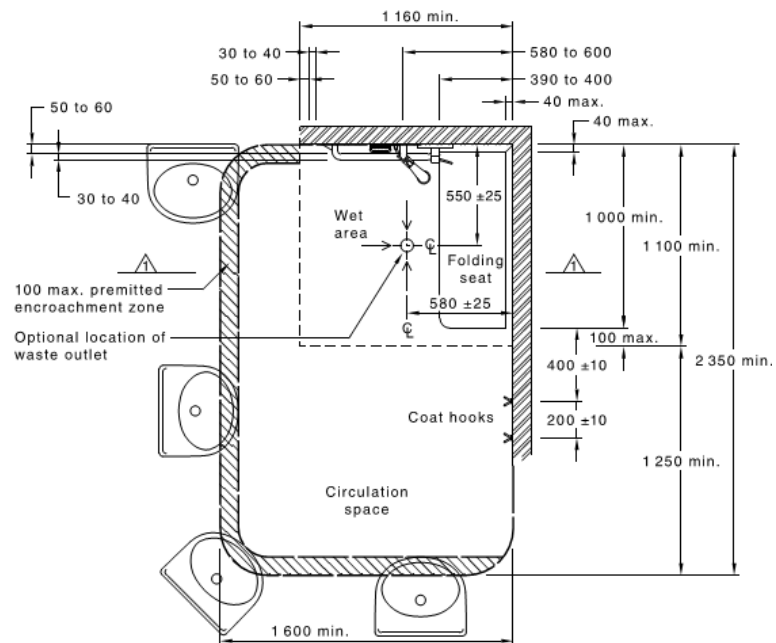
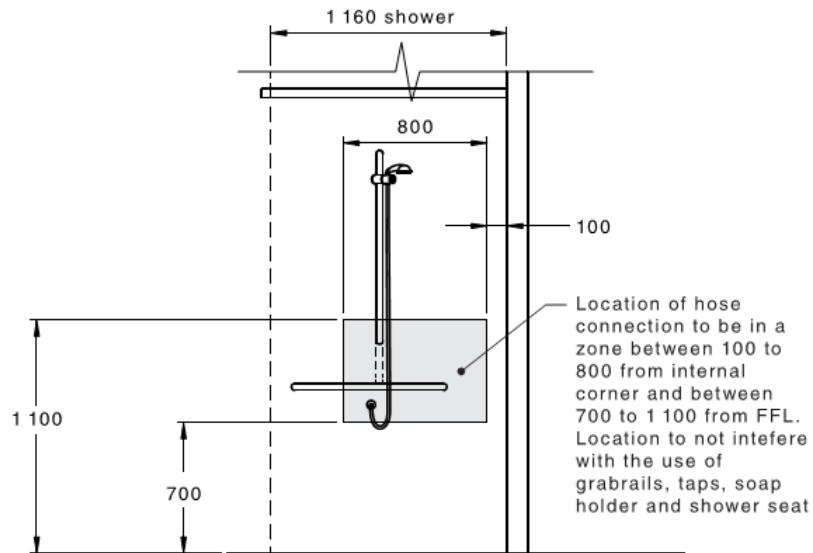
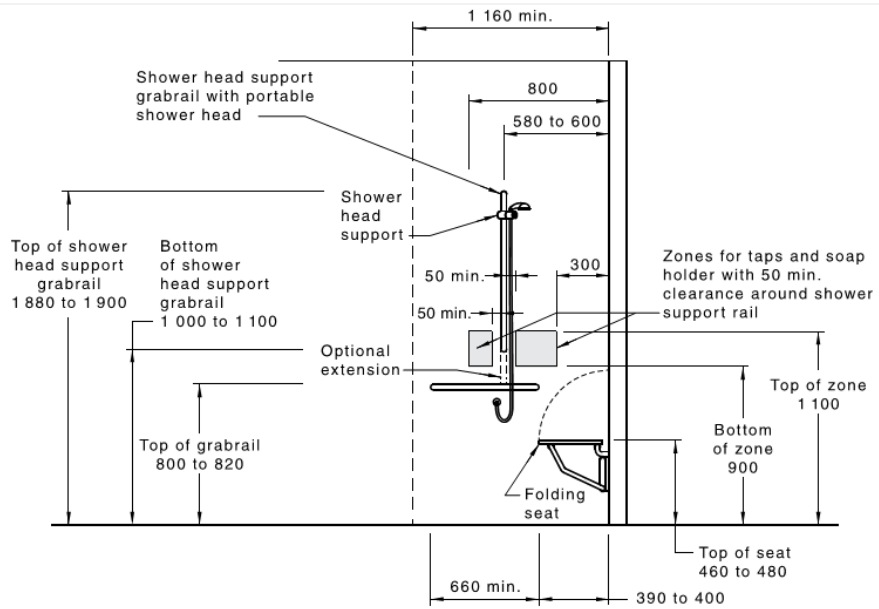

Figure 44

SAI Global Ltd License 1704-c045-2



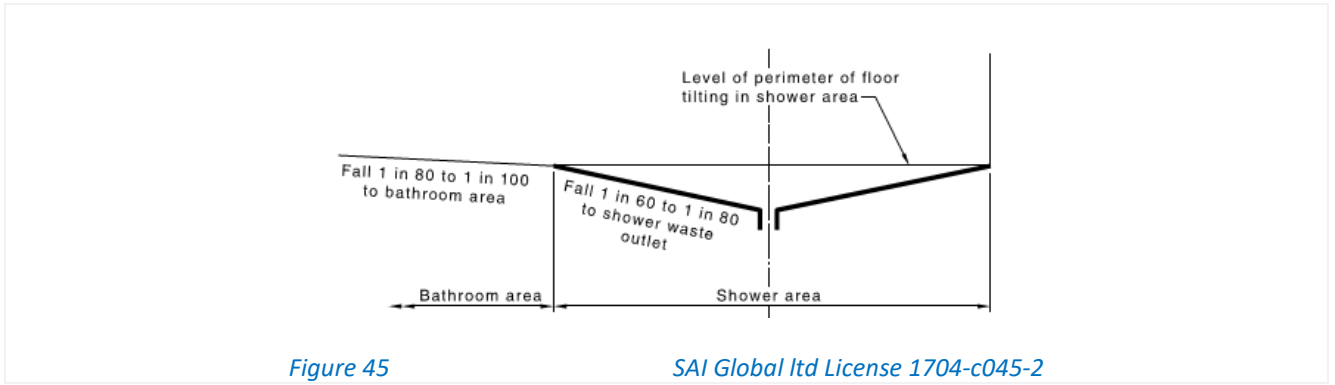

Figure 45

SAI Global Ltd License 1704-c045-2



Livable Housing Australia Design Elements

1. Dwelling access	Silver + Gold + Platinum
2. Dwelling entrance	Silver + Gold + Platinum
3. Internal doors & corridors	Silver + Gold + Platinum
4. Toilet	Silver + Gold + Platinum
5. Shower	Silver + Gold + Platinum
6. Reinforcement of bathroom & toilet walls	Silver + Gold + Platinum
7. Internal stairways	Silver + Gold + Platinum
8. Kitchen space	Gold + Platinum
9. Laundry space	Gold + Platinum
10. Ground (or entry level) bedroom space	Gold + Platinum
11. Switches and power points	Gold + Platinum
12. Door and tap hardware	Gold + Platinum
13. Family/living room space	Platinum
14. Window sills	Platinum
15. Flooring	Platinum

Performance Levels:

The levels of performance range from basic requirements through to best practice in livable home design. The levels are as follows:



Silver Level

Seven core livable housing design elements.

Focuses on the key structural and spatial elements that are critical to ensure future flexibility and adaptability of the home. Incorporating these features will avoid more costly home modification if required at a later date.

Gold Level

Enhanced requirements for most of the core livable housing design elements plus additional elements.

The gold level provides for more generous dimensions for most of the core livable housing design elements and introduces additional elements in areas such as the kitchen and bedroom.

Platinum Level

Some further enhanced requirements for the core livable housing design elements plus all remaining elements.

All 15 elements are featured in the platinum level. This level describes design elements that would better accommodate ageing in place and people with higher mobility needs. This level requires more generous dimensions for most of the core livable design elements and introduces additional elements for features such as the living room and flooring.

SEPP 65 – Part 4Q1 Livable Housing Guidelines

As per SEPP 65, 20% of the units are to be designed as 'Livable'. The development proposes 431 Units, of which 87 Units are to be designed as 'Livable'. However, a total of 243 units have been provided as Silver.

Summary

Total

Total Silver Livable Units	243 units
Total Units	431 units
	56%

Silver Livable Units Summary

1 Bed	29 unit
2 Bed	108 units
3 Bed	105 units
4 Bed	1 unit
Total Silver Livable Units	243 units
Total Livable Units	285 units
	85.3%

ADR: Additional Details Required

N/A: Not Applicable

C: Compliance

The 7 Livable Housing Design Elements Required for Silver Rating

1. Dwelling access

Performance Statement - There is a safe, continuous, step-free pathway from the street entrance and/or parking area to a dwelling entrance that is level.

ADR

N/A

C

.1 Is Access achieved from the site boundary or from a compliant car parking space?

- a) From car parking space
- b) From site boundary

Notes: Can be compliant at the CC stage

.2 If access is provided from the site boundary is this via walkway or ramp

- i. 1:20 or less grade
- ii. Grade between 1:20 and 1:14
- iii. 1:14 grade
- iv. 1:10 grade

Notes: Can be compliant at the CC stage

.3 Provide a safe, continuous step-free pathway from the front boundary of the property to an entry door to the dwelling.

Notes: Can be compliant at the CC stage

1.4 Where the grade of the pathway is under 1:14 The path of travel should have a minimum clear width of 1000mm and have:

- i. no steps;
- i. an even, firm, slip resistant surface;
- ii. a crossfall not more than 1:40;
- iii. a maximum pathway slop of 1:14

Notes: Can be compliant at the CC stage

1.5	Where a step ramp is provided. A step ramp may be incorporated at an entrance doorway where there is a change in height of 190mm or less. The step ramp should have a minimum clear width of 1000mm and provide: i. a maximum gradient of 1:10 ii. a minimum clear width of 1000mm iii. a maximum length of 1900mm	<input type="checkbox"/>	✓	<input type="checkbox"/>
1.6	Where a ramp (any grade of 1:20 or more) is part of the pathway, level landings no less than 1200mm in length, exclusive of the swing of the door or gate than opens onto them, must be provided at the head and foot of the ramp.	<input type="checkbox"/>	✓	<input type="checkbox"/>
1.7	The path of travel may be provided via an associated car parking space for the dwelling. Where a car parking space is relied upon as the safe and continuous pathway to the dwelling entrance, the space should incorporate: i. minimum dimensions of at least 3200mm (width) x 5400mm (length); ii. an even, firm and slip resistant surface; and iii. a level surface (1:40 maximum gradient, 1:33 maximum gradient for bitumen).	<input type="checkbox"/>	✓	<input type="checkbox"/>
2. Dwelling entrance <i>Performance Statement - There is at least one level (step-free) entrance into the dwelling to enable home occupants to easily enter and exit the dwelling.</i>		ADR	N/A	C
2.1	The dwelling should provide an entrance door with i. a minimum clear opening width of 820mm (see Figure 2(a)); ii. a level (step-free) transition and threshold (maximum vertical tolerance of 5mm between abutting surfaces is allowable provided the lip is rounded or beveled); and iii. reasonable shelter from the weather. Notes: Can be compliant at the CC stage	<input type="checkbox"/> <input type="checkbox"/> <input type="checkbox"/>	<input type="checkbox"/> <input type="checkbox"/> <input type="checkbox"/>	✓ ✓ ✓
2.2	A level landing area of at least 1200mm x 1200mm should be provided at the level (step free) entrance door. A level landing area at the entrance door should be provided on the arrival side of the door (i.e. the external side of the door) to allow a person to safely stand and then open the door. Notes: Can be compliant at the CC stage	<input type="checkbox"/>	<input type="checkbox"/>	✓
2.3	Where the threshold at the entrance exceeds 5mm and is less than 56mm, a ramped threshold may be provided (see Figure 1(b)). Notes: Can be compliant at the CC stage	<input type="checkbox"/>	<input type="checkbox"/>	✓
2.4	The level (step-free) entrance should be connected to the safe and continuous pathway as specified in Element 1. Notes: Can be compliant at the CC stage	<input type="checkbox"/>	<input type="checkbox"/>	✓
Note: The entrance must incorporate waterproofing and termite management requirements as specified in the NCC.				

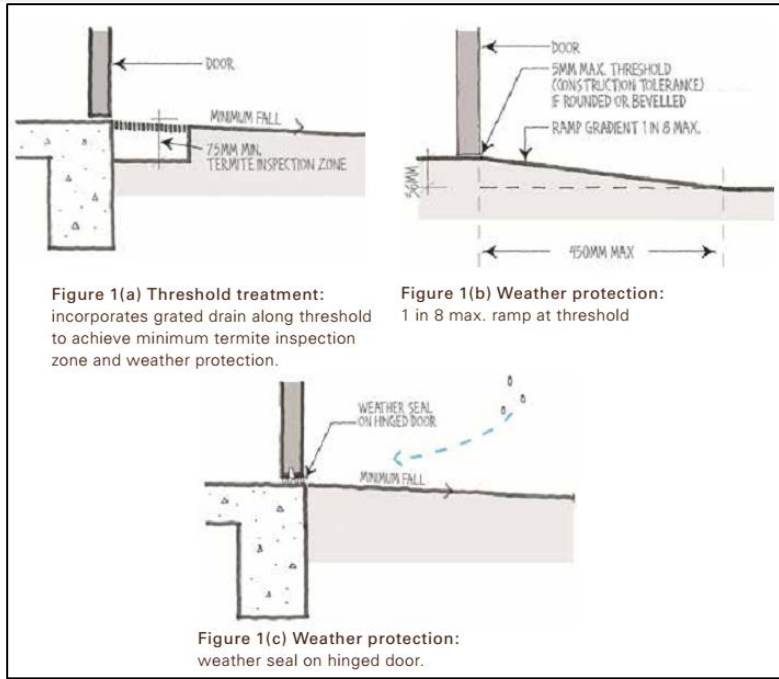

3. Internal doors & corridors

Performance Statement - Internal doors and corridors facilitate comfortable and unimpeded movement between spaces.

ADR

N/A

C

3.5 Doorways to rooms on the entry level used for living, dining, bedroom, bathroom, kitchen, laundry and sanitary compartment purposes should provide:

- i. a minimum clear opening width of 820mm (see Figure 2(a)), and
- ii. a level transition and threshold (maximum vertical tolerance of 5mm between abutting surfaces is allowable provided the lip is rounded or bevelled).

✓

✓

Notes: Can be compliant at the CC stage

3.5 Internal corridors/passageways to the doorways referred to in (a) should provide a minimum clear width of 1000mm.

✓

Notes: Can be compliant at the CC stage

Note: Corridor widths should be measured as described in Clause 6.3 of AS 1428.1 – 2009

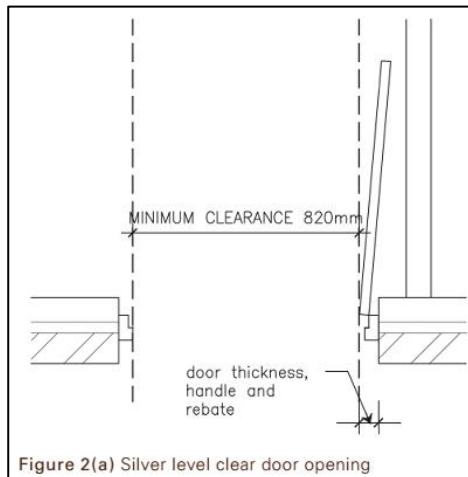

4. Toilet

Performance Statement - The ground (or entry) level has a toilet to

ADR

N/A

C

support easy access for home occupants and visitors.

- a. Dwellings should have a toilet on the ground (or entry) level that provides:
 - i. minimum clear width of 900mm between the walls of the bathroom if located in a separate room, or between amenities if located in a combined bathroom.
 - ii. a minimum 1200mm clear circulation space forward of the toilet pan exclusive of the swing of the door in accordance with Figure 3(a).
 - iii. The toilet pan should be located in the corner of the room (if the toilet is located in a combined toilet /bathroom) to enable installation of grabrails at a future date. Reinforcement guidelines for walls in bathrooms and toilets are found in element 6.







Notes: Can be compliant at the CC stage

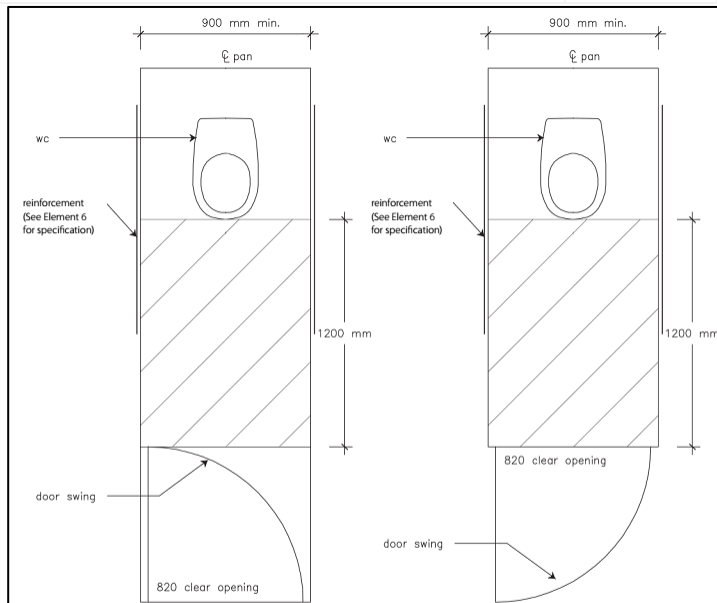

Figure 3(a) Silver level ground (or entry) level toilet layout and space requirements in a separate room.

5. Shower

Performance Statement - The bathroom and shower is designed for easy and independent access for all home occupants.

ADR

N/A

C

- 5.5 One bathroom should feature a slip resistant, hobless shower recess. Shower screens are permitted provided they can be easily removed at a later date.



- 5.5 The shower recess should be located in the corner of the room to enable the installation of grabrails at a future date.



Notes: Can be compliant at the CC stage

Note: For hobless specification please see Australian Standard AS3740-3.6. Reinforcement guidelines for walls in bathrooms and toilets are found in element 6.

6. Reinforcement of bathroom & toilet walls

Performance Statement - The bathroom and toilet walls are built to enable grabrails to be safely and economically installed.

ADR

N/A

C

- 6.5 Except for walls constructed of solid masonry or concrete, the walls around the shower, bath (if provided) and toilet should be reinforced to provide a fixing surface for the safe installation of grabrails.



Notes: Can be compliant at the CC stage

<p>6.5 The walls around the toilet are to be reinforced by installing:</p> <ul style="list-style-type: none"> i. noggings with a thickness of at least 25mm in accordance with Figure 6(a); or ii. sheeting with a thickness of at least 12mm in accordance with Figure 6(b). <p>Notes: Can be compliant at the CC stage</p>	<input type="checkbox"/> <input type="checkbox"/>	<input type="checkbox"/> <input type="checkbox"/>	<input checked="" type="checkbox"/> <input checked="" type="checkbox"/>
<p>6.5 The walls around the bath are to be reinforced by installing:</p> <ul style="list-style-type: none"> i. noggings with a thickness of at least 25mm in accordance with Figure 7(a); or ii. sheeting with a thickness of at least 12mm in accordance with Figure 7(b). 	<input type="checkbox"/> <input type="checkbox"/>	<input checked="" type="checkbox"/> <input checked="" type="checkbox"/>	<input type="checkbox"/> <input type="checkbox"/>
<p>6.5 The walls around the hobless shower recess are to be reinforced by installing:</p> <ul style="list-style-type: none"> i. noggings with a thickness of at least 25mm in accordance with Figure 8(a); or ii. sheeting with a thickness of at least 12mm in accordance with Figure 8(b). <p>Notes: Can be compliant at the CC stage</p>	<input type="checkbox"/> <input type="checkbox"/>	<input type="checkbox"/> <input type="checkbox"/>	<input checked="" type="checkbox"/> <input checked="" type="checkbox"/>

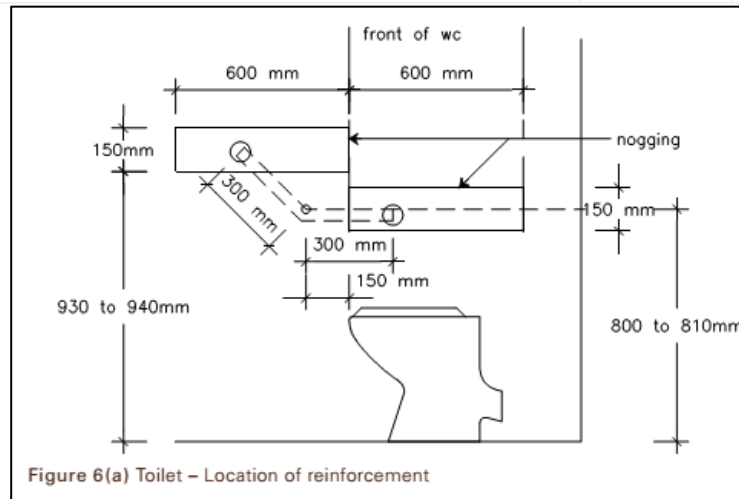

Figure 6(a) Toilet - Location of reinforcement

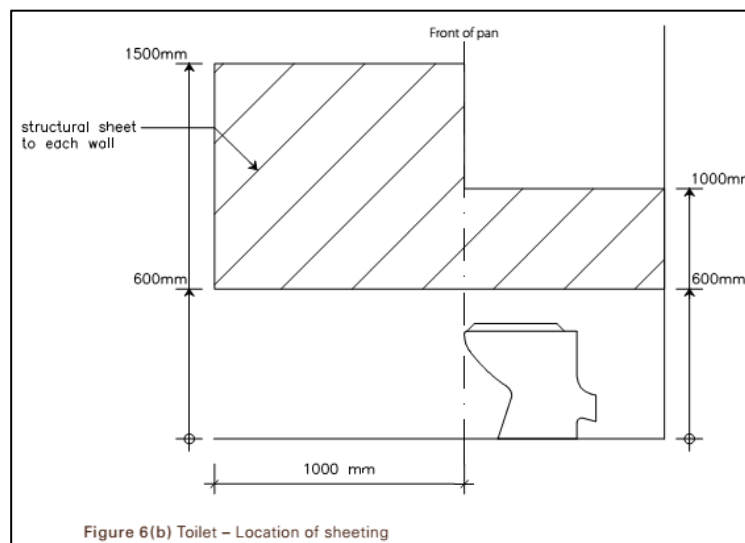
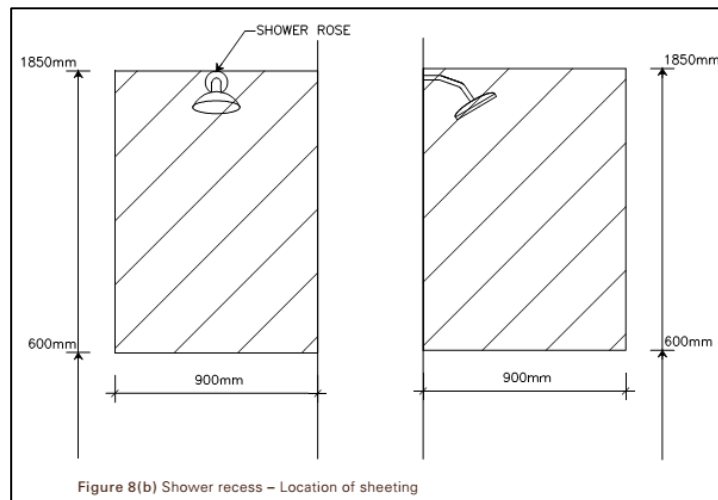
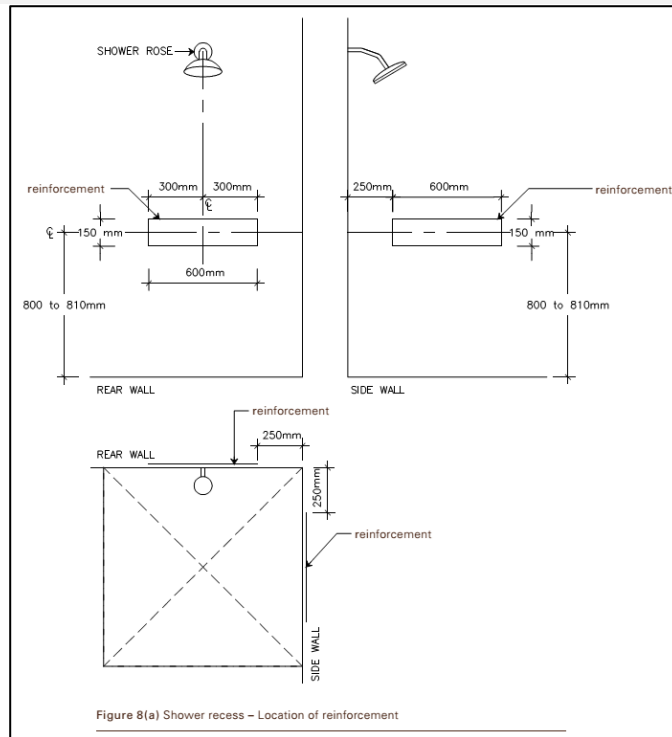

Figure 6(b) Toilet - Location of sheeting



7. Internal stairways

Performance Statement - Where installed, stairways are designed to reduce the likelihood of injury and also enable safety pathway.

ADR

N/A

C

7.5 Stairways in dwellings must feature a continuous handrail on one side of the stairway where there is a rise of more than 1m.



Notes: The steps must provide a slip resistant finish and suitable non-slip tread as specified in the NCC.

Gold Level Requirements

The development proposes 431 Units. 22 Gold Level Livable units have been provided, being units:

UG08, 109, 209, 309, 409, 509, 609, 1303, 714, 814, 914, 1014, 1114, 1214, 909, 1009, 1109, 1209, 1404, 1504, 1604, 1704

Summary

Total

Total Gold Livable Units	22 units
Total Units	431 units
	5.1%

Gold Livable Units Summary

1 Bed	0 unit
2 Bed	7 units
3 Bed	7 units
4 Bed	8 unit
Total Gold Livable Units	22 units
Total Livable Units	285 units
	7.7%

ADR: Additional Details Required

N/A: Not Applicable

C: Compliance

The 12 Livable Housing Design Elements Required for Gold Rating

1. Dwelling access

Performance Statement - There is a safe, continuous, step-free pathway from the street entrance and/or parking area to a dwelling entrance that is level.

	ADR	N/A	C
.1 Is Access achieved from the site boundary or from a compliant car parking space?			
c) From car parking space	<input type="checkbox"/>	<input checked="" type="checkbox"/>	<input type="checkbox"/>
d) From site boundary	<input type="checkbox"/>	<input type="checkbox"/>	<input checked="" type="checkbox"/>
Notes: Can be compliant at the CC stage			
.2 If access is provided from the site boundary is this via walkway or ramp			
v. 1:20 or less grade	<input type="checkbox"/>	<input type="checkbox"/>	<input checked="" type="checkbox"/>
vi. Grade between 1:20 and 1:	<input type="checkbox"/>	<input checked="" type="checkbox"/>	<input type="checkbox"/>
vii. 1:14 grade	<input type="checkbox"/>	<input checked="" type="checkbox"/>	<input type="checkbox"/>
viii. 1:10 grade	<input type="checkbox"/>	<input checked="" type="checkbox"/>	<input type="checkbox"/>
Notes: Can be compliant at the CC stage			
.3 Provide a safe, continuous step-free pathway from the front boundary of the property to an entry door to the dwelling.	<input type="checkbox"/>	<input type="checkbox"/>	<input checked="" type="checkbox"/>
Notes: Can be compliant at the CC stage			
1.4 Where the grade of the pathway is under 1:14 The path of travel should have a minimum clear width of 1100mm and have:			
j. no steps;	<input type="checkbox"/>	<input checked="" type="checkbox"/>	<input type="checkbox"/>
iv. an even, firm, slip resistant surface;	<input type="checkbox"/>	<input checked="" type="checkbox"/>	<input type="checkbox"/>
v. a crossfall not more than 1:40;	<input type="checkbox"/>	<input checked="" type="checkbox"/>	<input type="checkbox"/>
vi. a maximum pathway slop of 1:14	<input type="checkbox"/>	<input checked="" type="checkbox"/>	<input type="checkbox"/>

1.5 Where a step ramp is provided. A step ramp may be incorporated at an entrance doorway where there is a change in height of 190mm or less. The step ramp should have a minimum clear width of 1100mm and provide: iv. a maximum gradient of 1:10 v. a minimum clear width of 1100mm vi. a maximum length of 1900mm	<input type="checkbox"/>	✓	<input type="checkbox"/>
2.6 Where a ramp (any grade of 1:20 or more) is part of the pathway, level landings no less than 1200mm in length, exclusive of the swing of the door or gate than opens onto them, must be provided at the head and foot of the ramp.	<input type="checkbox"/>	✓	<input type="checkbox"/>
2.7 The path of travel may be provided via an associated car parking space for the dwelling. Where a car parking space is relied upon as the safe and continuous pathway to the dwelling entrance, the space should incorporate: iv. minimum dimensions of at least 3200mm (width) x 5400mm (length); v. an even, firm and slip resistant surface; and vi. a level surface (1:40 maximum gradient, 1:33 maximum gradient for bitumen).	<input type="checkbox"/>	✓	<input type="checkbox"/>
1.8 Additionally, the following are required: vii. a vertical clearance over the parking space of at least 2500mm; and viii. a covered parking space to ensure protection from the weather	<input type="checkbox"/>	✓	<input type="checkbox"/>
Note:	<input type="checkbox"/>	✓	<input type="checkbox"/>
2. Dwelling entrance Performance Statement - There is at least one level (step-free) entrance into the dwelling to enable home occupants to easily enter and exit the dwelling.	ADR	N/A	C
2.1 The dwelling should provide an entrance door with iv. a minimum clear opening width of 850mm (see Figure 2(c)); v. a level (step-free) transition and threshold (maximum vertical tolerance of 5mm between abutting surfaces is allowable provided the lip is rounded or beveled); and vi. reasonable shelter from the weather.	<input type="checkbox"/>	<input type="checkbox"/>	✓
Notes: Can be compliant at the CC stage	<input type="checkbox"/>	<input type="checkbox"/>	✓
2.2 A level landing area of at least 1350mm x 1350mm should be provided at the level (step free) entrance door. A level landing area at the entrance door should be provided on the arrival side of the door (i.e. the external side of the door) to allow a person to safely stand and then open the door.	<input type="checkbox"/>	<input type="checkbox"/>	✓
Notes: Can be compliant at the CC stage			
2.5 Where the threshold at the entrance exceeds 5mm and is less than 56mm, a ramped threshold may be provided (see Figure 1(b)).	<input type="checkbox"/>	<input type="checkbox"/>	✓
Notes: Can be compliant at the CC stage			
2.6 The level (step-free) entrance should be connected to the safe and continuous pathway as specified in Element 1.	<input type="checkbox"/>	<input type="checkbox"/>	✓
Notes: Can be compliant at the CC stage			
Note: The entrance must incorporate waterproofing and termite management requirements as specified in the NCC.			

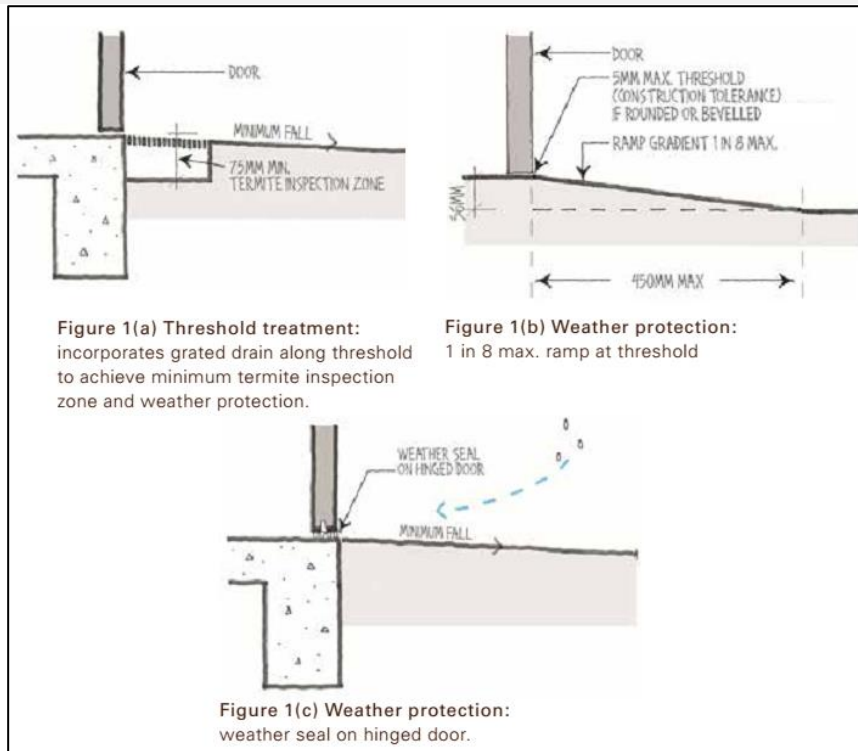

3. Internal doors & corridors

Performance Statement - Internal doors and corridors facilitate comfortable and unimpeded movement between spaces.

ADR

N/A

C

- .1 Doorways to rooms on the entry level used for living, dining, bedroom, bathroom, kitchen, laundry and sanitary compartment purposes should provide:
- iii. a minimum clear opening width of 850mm (see Figure 2(b)), and
 - iv. a level transition and threshold (maximum vertical tolerance of 5mm between abutting surfaces is allowable provided the lip is rounded or bevelled).

✓

✓

Notes: Can be compliant at the CC stage

- .2 Internal corridors/passageways to the doorways referred to in (a) should provide a minimum clear width of 1200mm.

✓

Note: Corridor widths should be measured as described in Clause 6.3 of AS 1428.1 – 2009

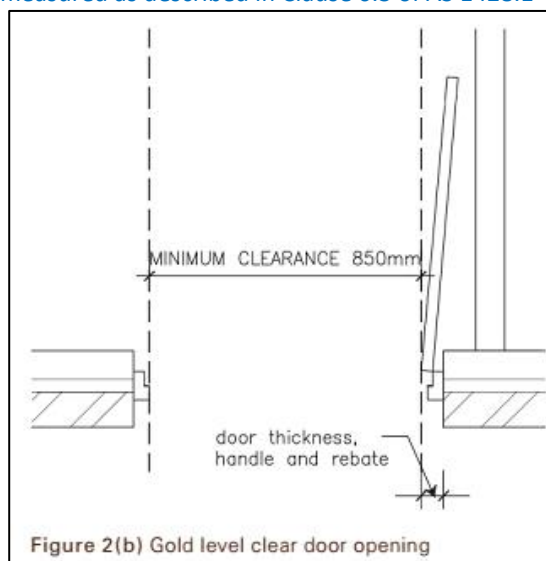

4. Toilet		ADR	N/A	C
Performance Statement - The ground (or entry) level has a toilet to support easy access for home occupants and visitors.				
.1	Dwellings should have a toilet on the ground (or entry) level that provides:			
iv.	minimum clear width of 1200mm between the walls of the bathroom if located in a separate room, or between amenities if located in a combined bathroom.	<input type="checkbox"/>	<input type="checkbox"/>	✓
v.	a minimum 1200mm clear circulation space forward of the toilet pan exclusive of the swing of the door in accordance with Figure 3(a).	<input type="checkbox"/>	<input type="checkbox"/>	✓
vi.	The toilet pan should be located in the corner of the room (if the toilet is located in a combined toilet /bathroom) to enable installation of grabrails at a future date. Reinforcement guidelines for walls in bathrooms and toilets are found in element 6.	<input type="checkbox"/>	<input type="checkbox"/>	✓
Notes: Can be compliant at the CC stage				
Note: Compliance with the platinum level does not equate to compliance with AS 1428.1 2009 for accessible sanitary facilities.				
5. Shower		ADR	N/A	C
Performance Statement - The bathroom and shower is designed for easy and independent access for all home occupants.				
.2	One bathroom should feature a slip resistant, hobless shower recess. Shower screens are permitted provided they can be easily removed at a later date.	<input type="checkbox"/>	<input type="checkbox"/>	✓
Notes: Can be compliant at the CC stage				
.3	The shower recess should be located in the corner of the room to enable the installation of grabrails at a future date.	<input type="checkbox"/>	<input type="checkbox"/>	✓
Notes: Can be compliant at the CC stage				
.4	The hobless shower recess should be located in a bathroom on the ground (or entry) level.	<input type="checkbox"/>	<input type="checkbox"/>	✓
Notes: Can be compliant at the CC stage				
.5	The hobless shower recess described should provide minimum dimensions of at least 900mm (width) x 900mm (length). A level transition and threshold (maximum vertical tolerance of 5mm between abutting surfaces is allowable provided the lip is rounded or bevelled); and	<input type="checkbox"/>	<input type="checkbox"/>	✓
Notes: Can be compliant at the CC stage				
.6	The hobless shower recess described should provide a clear space of at least 1200mm(width) x 1200mm (length) forward of the shower recess as detailed in Figure 5(a).	<input type="checkbox"/>	<input type="checkbox"/>	✓
Notes: Can be compliant at the CC stage				
Note: For hobless specification please see Australian Standard AS3740-3.6. Reinforcement guidelines for walls in bathrooms and toilets are found in element 6.				

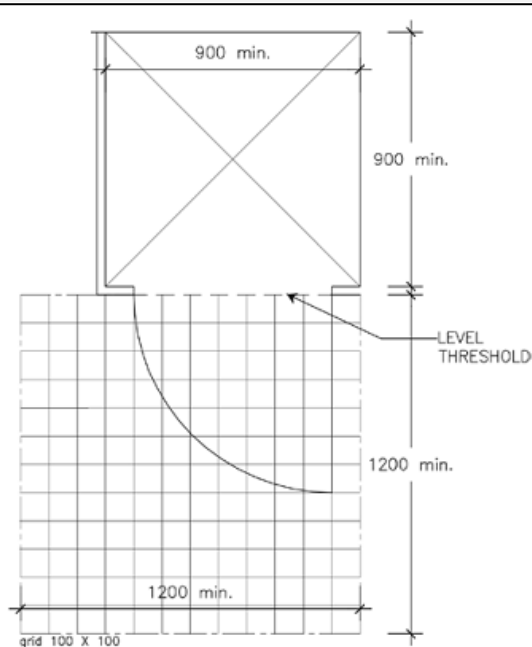

Figure 5(a) Gold level circulation space requirements for shower recess

6. Reinforcement of bathroom & toilet walls

Performance Statement - The bathroom and toilet walls are built to enable grabrails to be safely and economically installed.

ADR

N/A

C

- a. Except for walls constructed of solid masonry or concrete, the walls around the shower, bath (if provided) and toilet should be reinforced to provide a fixing surface for the safe installation of grabrails.

✓

Notes: Can be compliant at the CC stage

- b. The walls around the toilet are to be reinforced by installing:
- iii. noggings with a thickness of at least 25mm in accordance with Figure 6(a); or
- iv. sheeting with a thickness of at least 12mm in accordance with Figure 6(b).

✓

✓

Notes: Can be compliant at the CC stage

- c. The walls around the bath are to be reinforced by installing:
- iii. noggings with a thickness of at least 25mm in accordance with Figure 7(a); or
- iv. sheeting with a thickness of at least 12mm in accordance with Figure 7(b).

✓

✓

Notes: Can be compliant at the CC stage

- d. The walls around the hobless shower recess are to be reinforced by installing:
- iii. noggings with a thickness of at least 25mm in accordance with Figure 8(a); or
- iv. sheeting with a thickness of at least 12mm in accordance with Figure 8(b).

✓

✓

Notes: Can be compliant at the CC stage

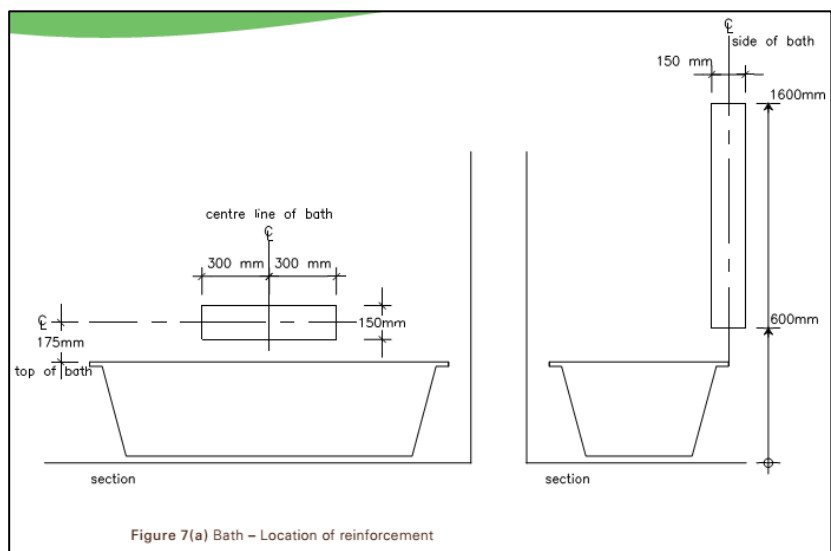
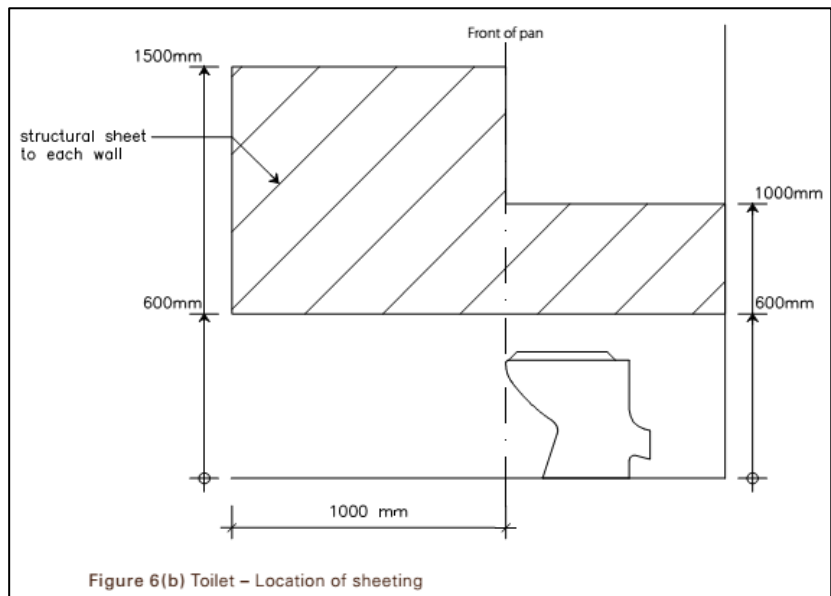
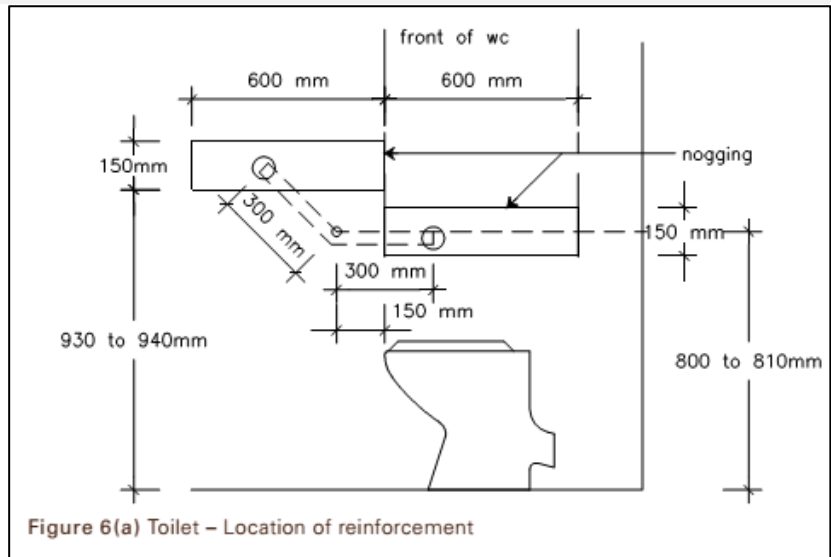

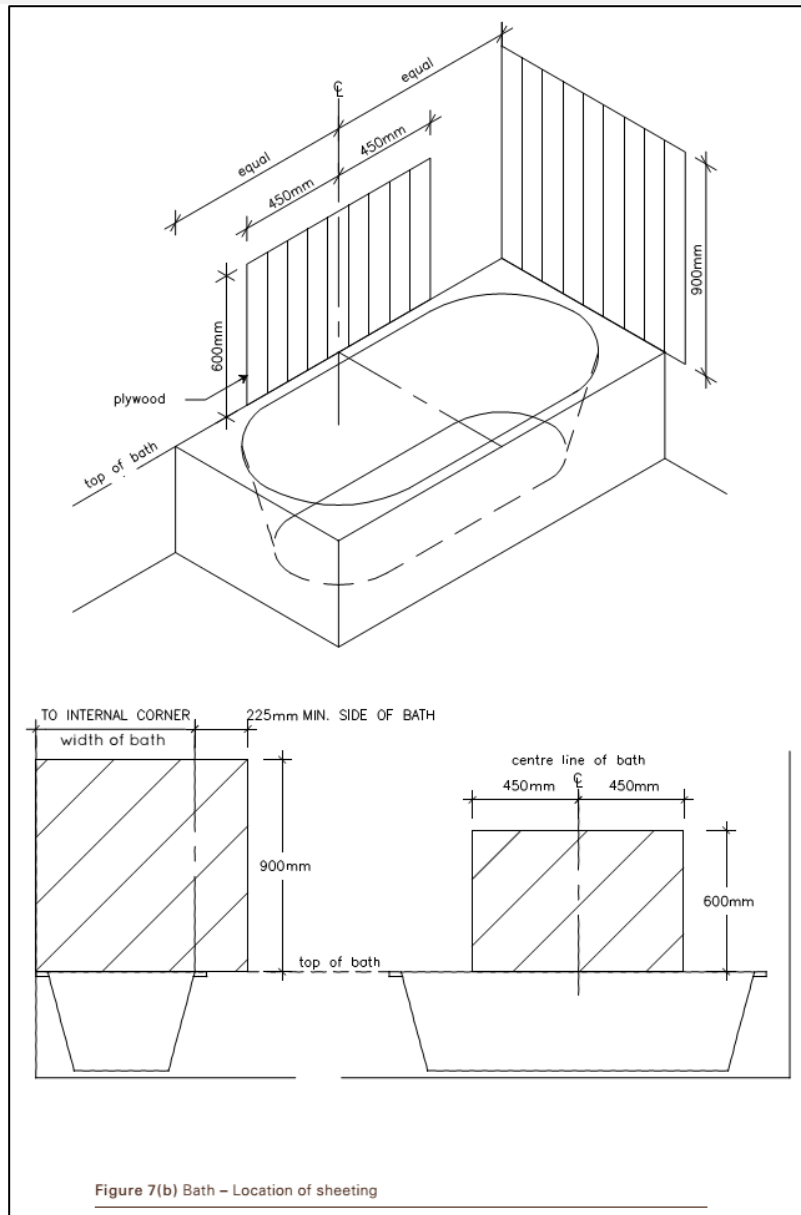

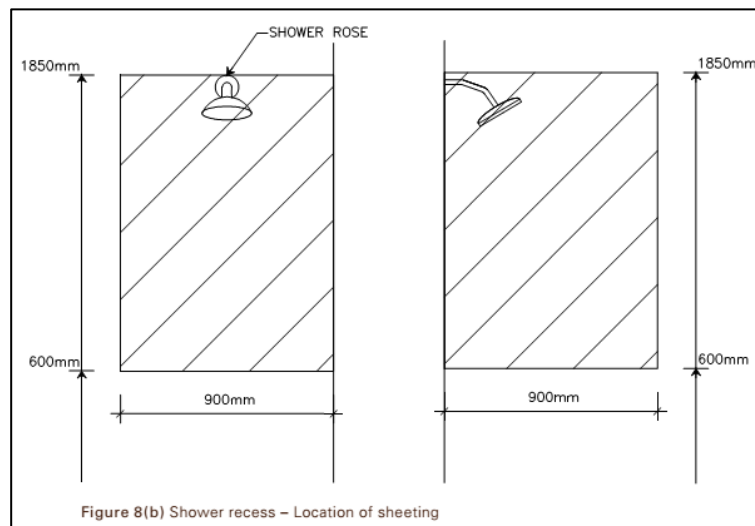
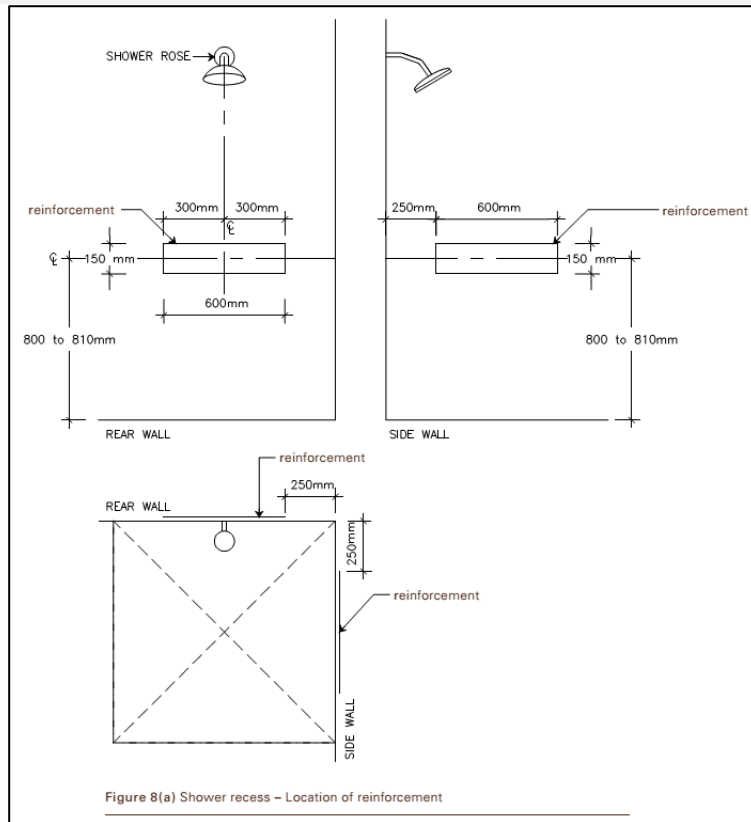

7. Internal stairways

Performance Statement - Where installed, stairways are designed to reduce the likelihood of injury and also enable safety pathway.

	ADR	N/A	C
a. Stairways in dwellings must feature a continuous handrail on one side of the stairway where there is a rise of more than 1m.	<input type="checkbox"/>	<input checked="" type="checkbox"/>	<input type="checkbox"/>
b. Stairways in dwellings must feature a minimum clear width of 1000mm;	<input type="checkbox"/>	<input checked="" type="checkbox"/>	<input type="checkbox"/>
c. Stairways in dwellings must be straight in design; and	<input type="checkbox"/>	<input checked="" type="checkbox"/>	<input type="checkbox"/>
d. Stairways in dwellings must be positioned adjoining a load bearing wall.	<input type="checkbox"/>	<input checked="" type="checkbox"/>	<input type="checkbox"/>

Note: The steps must provide a slip resistant finish and suitable non-slip tread as specified in the NCC.			
8. Kitchen space <i>Performance Statement - The kitchen space is designed to support ease of movement between fixed benches and to support easy adaptation.</i>	ADR	N/A	C
a. The kitchen space should be designed to support ease of movement and adaptation with at least 1200mm clearance in front of fixed benches and appliances (excluding handles); and Notes: Can be compliant at the CC stage	<input type="checkbox"/>	<input type="checkbox"/>	✓
b. Slip resistant flooring to be provided Notes: Can be compliant at the CC stage	<input type="checkbox"/>	<input type="checkbox"/>	✓
c. Floor finishes should extend under kitchen cabinetry to enable cupboards to be removed without affecting the flooring. Where fixtures cannot be easily removed (e.g. ovens which are built in) the floor finishes should not be continued. If relying on advice from a third party, Assessors are advised to provide a note in the comments section. Notes: Can be compliant at the CC stage	<input type="checkbox"/>	<input type="checkbox"/>	✓
9. Laundry space <i>Performance Statement - The laundry space is designed to support ease of movement between fixed benches and to support easy adaptation.</i>	ADR	N/A	C
a. The laundry space should be designed to support ease of movement and adaptation with at least 1200mm clear width provided in front of fixed benches and appliances (excluding handles). Where the appliances are not installed then the recessed area provision for an appliance shall be a minimum of 600mm in depth. Notes: Can be compliant at the CC stage	<input type="checkbox"/>	<input type="checkbox"/>	✓
b. Slip resistant flooring to be provided Notes: Can be compliant at the CC stage	<input type="checkbox"/>	<input type="checkbox"/>	✓
c. Floor finishes should extend under laundry cabinetry to enable cupboards to be removed without affecting the flooring. Where fixtures cannot be easily removed the floor finishes should not be continued. If relying on advice from a third party, Assessors are advised to provide a note in the comments section. Notes: Can be compliant at the CC stage	<input type="checkbox"/>	<input type="checkbox"/>	✓
10. Ground (or entry level) bedroom space <i>Performance Statement - There is a space on the ground (or entry) level that can be used as a bedroom.</i>	ADR	N/A	C
a. The dwelling should feature a space (or room) on the ground (or entry) level that is of as of at least 10m ² clearance exclusive of wardrobes; skirtings and wall lining; Notes: Can be compliant at the CC stage	<input type="checkbox"/>	<input type="checkbox"/>	✓
b. Space provides for a minimum path of travel of 1000mm on at least one side of the bed. Notes: Can be compliant at the CC stage	<input type="checkbox"/>	<input type="checkbox"/>	✓
11. Switches and power points	ADR	N/A	C

Performance Statement - Light switches and power points are located at heights that are easy to reach for all home occupants.				
<p>a. Light switches should be positioned in a consistent location:</p> <p>i. between 900mm – 1100mm above the finished floor level; and</p> <p>ii. horizontally aligned with the door handle at the entrance to a room.</p> <p>Notes: Can be compliant at the CC stage</p>	<input type="checkbox"/>	<input type="checkbox"/>	✓	
<p>b. Power points should be installed not lower than 300mm above the finished floor level</p> <p>Note:</p>	<input type="checkbox"/>	<input type="checkbox"/>	✓	
12. Door and tap hardware				
Performance Statement - Home occupants are able to easily and independently open and close doors and safely use tap hardware.		ADR	N/A	C
<p>a. Doorways should feature door hardware installed at between 900mm – 1100mm above the finished floor.</p> <p>Notes: Can be compliant at the CC stage</p>	<input type="checkbox"/>	<input type="checkbox"/>	✓	



Platinum Level Requirements

The development proposes 431 Units. 20 Platinum Level Livable units have been provided, being units:

303	903	304	904
403	1003	404	1004
503	1103	504	1104
603	1203	604	1204
703		704	
803		804	

Summary

Total

Total Platinum Livable Units	20 units
Total Units	431 units
	4.6%

Platinum Livable Units Summary

1 Bed	0 units
2 Bed	20 units
3 Bed	0 units
4 Bed	0 units
Total Gold Livable Units	20 units
Total Livable Units	285 units
	7%

ADR: Additional Details Required

N/A: Not Applicable

C: Compliance

The 15 Livable Housing Design Elements Required for Platinum Rating

3. Dwelling access

Performance Statement - There is a safe, continuous, step-free pathway from the street entrance and/or parking area to a dwelling entrance that is level.

	ADR	N/A	C
3.5 Is Access achieved from the site boundary or from a compliant car parking space?			
e) From car parking space	<input type="checkbox"/>	<input checked="" type="checkbox"/>	<input type="checkbox"/>
f) From site boundary	<input type="checkbox"/>	<input type="checkbox"/>	<input checked="" type="checkbox"/>
Notes: Can be compliant at the CC stage			
3.5 If access is provided from the site boundary is this via walkway or ramp			
ix. 1:20 or less grade	<input type="checkbox"/>	<input type="checkbox"/>	<input checked="" type="checkbox"/>
x. Grade between 1:20 and 1:	<input type="checkbox"/>	<input checked="" type="checkbox"/>	<input type="checkbox"/>
xi. 1:14 grade	<input type="checkbox"/>	<input checked="" type="checkbox"/>	<input type="checkbox"/>
xii. 1:10 grade	<input type="checkbox"/>	<input checked="" type="checkbox"/>	<input type="checkbox"/>
Notes: Can be compliant at the CC stage			
3.5 Provide a safe, continuous step-free pathway from the front boundary of the property to an entry door to the dwelling.	<input type="checkbox"/>	<input type="checkbox"/>	<input checked="" type="checkbox"/>
Notes: Can be compliant at the CC stage			
1.4 Where the grade of the pathway is under 1:14 The path of travel should have a minimum clear width of 1200mm and have:			
k. no steps;	<input type="checkbox"/>	<input type="checkbox"/>	<input checked="" type="checkbox"/>
vii. an even, firm, slip resistant surface;	<input type="checkbox"/>	<input type="checkbox"/>	<input checked="" type="checkbox"/>

<ul style="list-style-type: none"> viii. a crossfall not more than 1:40; ix. a maximum pathway slop of 1:14 <p>Notes: Can be compliant at the CC stage</p>	<input type="checkbox"/>	<input type="checkbox"/>	✓
<ul style="list-style-type: none"> ix. a maximum pathway slop of 1:14 	<input type="checkbox"/>	<input type="checkbox"/>	✓
<p>3.5 Where a step ramp is provided. A step ramp may be incorporated at an entrance doorway where there is a change in height of 190mm or less. The step ramp should have a minimum clear width of 1200mm and provide:</p> <ul style="list-style-type: none"> vii. a maximum gradient of 1:10 viii. a minimum clear width of 1200mm ix. a maximum length of 1900mm 	<input type="checkbox"/>	✓	<input type="checkbox"/>
<p>3.6 Where a ramp (any grade of 1:20 or more) is part of the pathway, level landings no less than 1200mm in length, exclusive of the swing of the door or gate than opens onto them, must be provided at the head and foot of the ramp.</p>	<input type="checkbox"/>	✓	<input type="checkbox"/>
<p>3.7 The path of travel may be provided via an associated car parking space for the dwelling. Where a car parking space is relied upon as the safe and continuous pathway to the dwelling entrance, the space should incorporate:</p> <ul style="list-style-type: none"> ix. minimum dimensions of at least 3800mm (width) x 6000mm (length); x. an even, firm and slip resistant surface; and xi. a level surface (1:40 maximum gradient, 1:33 maximum gradient for bitumen). 	<input type="checkbox"/>	✓	<input type="checkbox"/>
<p>2.8 Additionally, the following are required:</p> <ul style="list-style-type: none"> xii. a vertical clearance over the parking space of at least 2500mm; and xiii. a covered parking space to ensure protection from the weather 	<input type="checkbox"/>	✓	<input type="checkbox"/>
	<input type="checkbox"/>	✓	<input type="checkbox"/>
<p>2. Dwelling entrance Performance Statement - There is at least one level (step-free) entrance into the dwelling to enable home occupants to easily enter and exit the dwelling.</p>			
	ADR	N/A	C
<p>2.4 The dwelling should provide an entrance door with</p> <ul style="list-style-type: none"> vii. a minimum clear opening width of 900mm (see Figure 2(c)); viii. a level (step-free) transition and threshold (maximum vertical tolerance of 5mm between abutting surfaces is allowable provided the lip is rounded or beveled); and ix. reasonable shelter from the weather. <p>Notes: Can be compliant at the CC stage</p>	<input type="checkbox"/>	<input type="checkbox"/>	✓
	<input type="checkbox"/>	<input type="checkbox"/>	✓
	<input type="checkbox"/>	<input type="checkbox"/>	✓
<p>2.2 A level landing area of at least 1500mm x 1500mm should be provided at the level (step free) entrance door. A level landing area at the entrance door should be provided on the arrival side of the door (i.e. the external side of the door) to allow a person to safely stand and then open the door.</p> <p>Notes: Can be compliant at the CC stage</p>	<input type="checkbox"/>	<input type="checkbox"/>	✓
<p>2.7 Where the threshold at the entrance exceeds 5mm and is less than 56mm, a ramped threshold may be provided (see Figure 1(b)).</p> <p>Notes: Can be compliant at the CC stage</p>	<input type="checkbox"/>	<input type="checkbox"/>	✓
<p>2.8 The level (step-free) entrance should be connected to the safe and continuous pathway as specified in Element 1.</p> <p>Notes: Can be compliant at the CC stage</p>	<input type="checkbox"/>	<input type="checkbox"/>	✓

Note: The entrance must incorporate waterproofing and termite management requirements as specified in the NCC.

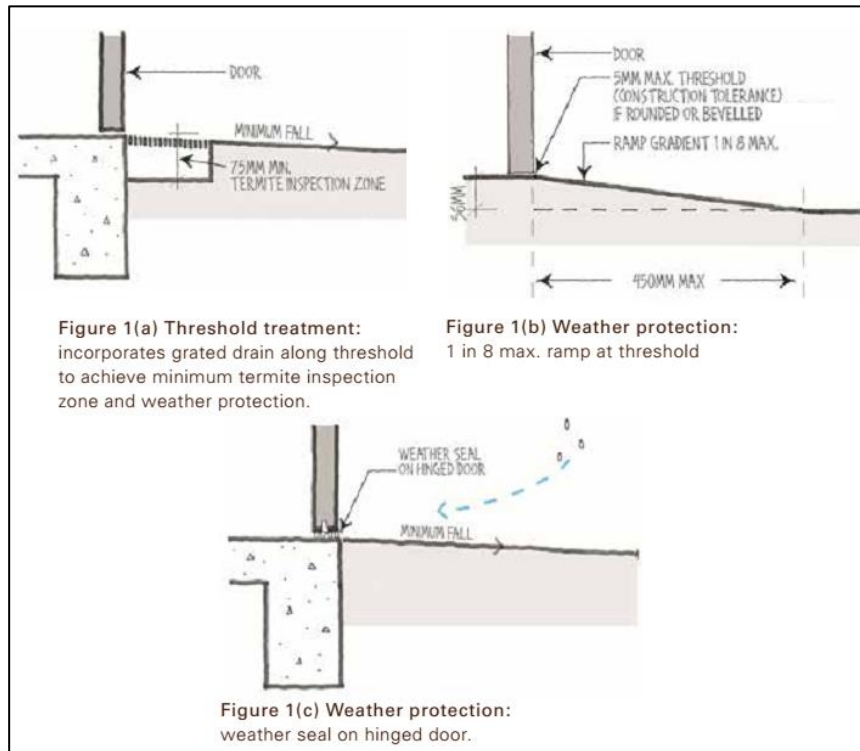

3. Internal doors & corridors

Performance Statement - Internal doors and corridors facilitate comfortable and unimpeded movement between spaces.

ADR

N/A

C

3.4 Doorways to rooms on the entry level used for living, dining, bedroom, bathroom, kitchen, laundry and sanitary compartment purposes should provide:

- v. a minimum clear opening width of 900mm (see Figure 2(c)), and
- vi. a level transition and threshold (maximum vertical tolerance of 5mm between abutting surfaces is allowable provided the lip is rounded or bevelled).

✓

✓

Notes: Can be compliant at the CC stage

3.4 Internal corridors/passageways to the doorways referred to in (a) should provide a minimum clear width of 1200mm.

✓

Note: Corridor widths should be measured as described in Clause 6.3 of AS 1428.1 – 2009

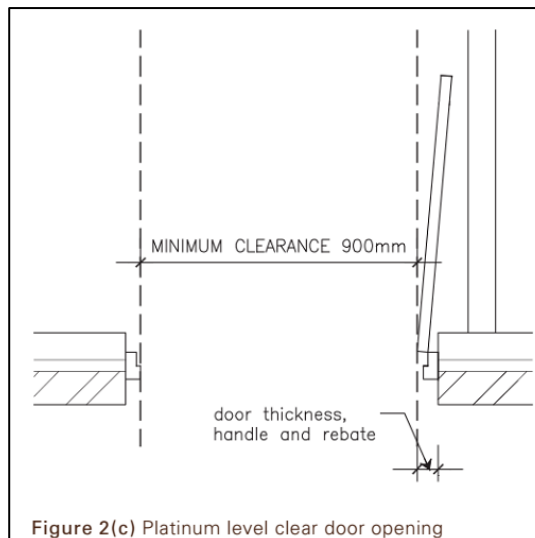

4. Toilet

Performance Statement - The ground (or entry) level has a toilet to support easy access for home occupants and visitors.

ADR

N/A

C

4.4 Dwellings should have a toilet on the ground (or entry) level that provides:

- vii. minimum clear width of 1200mm between the walls of the bathroom if located in a separate room, or between amenities if located in a combined bathroom.
- viii. a minimum 1200mm clear circulation space forward of the toilet pan exclusive of the swing of the door in accordance with Figure 3(a).
- ix. The toilet pan should be located in the corner of the room (if the toilet is located in a combined toilet /bathroom) to enable installation of grabrails at a future date. Reinforcement guidelines for walls in bathrooms and toilets are found in element 6.
- x. a toilet seat positioned between 450mm – 460mm from the nearest wall as measured from the centre line of the toilet;
- xiii. 600mm minimum clearance forward of the cistern measured from the front of the cistern to the front of the toilet seat. 800mm (+/-10mm) clearance is required if the cistern is recessed; and
- xiv. a height for the seat of between 460mm-480mm above the finished floor level.

✓

✓

✓

✓

✓

✓

Notes: Can be compliant at the CC stage

Note: Compliance with the platinum level does not equate to compliance with AS 1428.1 2009 for accessible sanitary facilities.

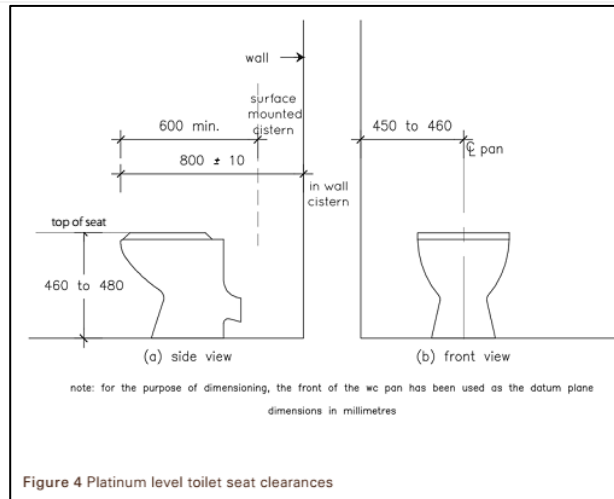

Figure 4 Platinum level toilet seat clearances

5. Shower

Performance Statement - The bathroom and shower is designed for easy and independent access for all home occupants.

ADR

N/A

C

5.4 One bathroom should feature a slip resistant, hobless shower recess. Shower screens are permitted provided they can be easily removed at a later date.

Notes: Can be compliant at the CC stage

✓

5.4 The shower recess should be located in the corner of the room to enable the installation of grabrails at a future date.

Notes: Can be compliant at the CC stage

✓

5.4 The hobless shower recess should be located in a bathroom on the ground (or entry) level. Notes: Can be compliant at the CC stage	<input type="checkbox"/>	<input type="checkbox"/>	✓
5.4 The hobless shower recess described should provide minimum dimensions of at least 1160mm (width) x 1100mm (length). A level transition and threshold (maximum vertical tolerance of 5mm between abutting surfaces is allowable provided the lip is rounded or bevelled); and Notes: Can be compliant at the CC stage	<input type="checkbox"/>	<input type="checkbox"/>	✓
5.4 The hobless shower recess described should provide a clear space of at least 1600mm(width) x 1400mm (length) forward of the shower recess as detailed in Figure 5(b). Notes: Can be compliant at the CC stage	<input type="checkbox"/>	<input type="checkbox"/>	✓

Note: For hobless specification please see Australian Standard AS3740-3.6. Reinforcement guidelines for walls in bathrooms and toilets are found in element 6.

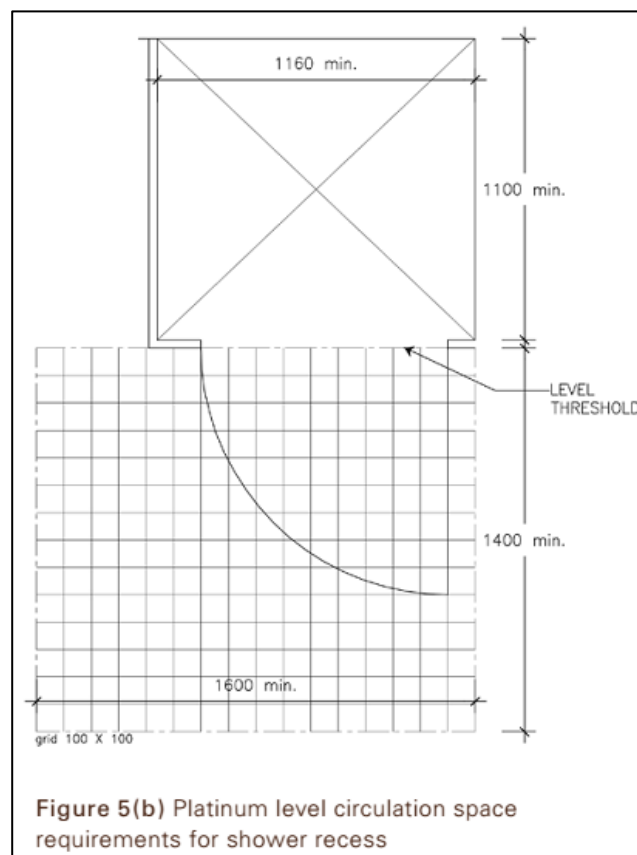

6. Reinforcement of bathroom & toilet walls

Performance Statement - The bathroom and toilet walls are built to enable grabrails to be safely and economically installed.

ADR

N/A

C

6.4 Except for walls constructed of solid masonry or concrete, the walls around the shower, bath (if provided) and toilet should be reinforced to provide a fixing surface for the safe installation of grabrails. Notes: Can be compliant at the CC stage	<input type="checkbox"/>	<input type="checkbox"/>	✓
6.4 The walls around the toilet are to be reinforced by installing: <ul style="list-style-type: none"> v. noggings with a thickness of at least 25mm in accordance with Figure 6(a); or vi. sheeting with a thickness of at least 12mm in accordance with Figure 6(b). Notes: Can be compliant at the CC stage	<input type="checkbox"/>	<input type="checkbox"/>	✓
	<input type="checkbox"/>	<input type="checkbox"/>	✓

- 6.4** The walls around the bath are to be reinforced by installing:
- v. noggings with a thickness of at least 25mm in accordance with Figure 7(a); or
 - vi. sheeting with a thickness of at least 12mm in accordance with Figure 7(b).



Notes: Can be compliant at the CC stage

- 6.4** The walls around the hobless shower recess are to be reinforced by installing:

- v. noggings with a thickness of at least 25mm in accordance with Figure 8(a); or
- vi. sheeting with a thickness of at least 12mm in accordance with Figure 8(b).



Notes: Can be compliant at the CC stage

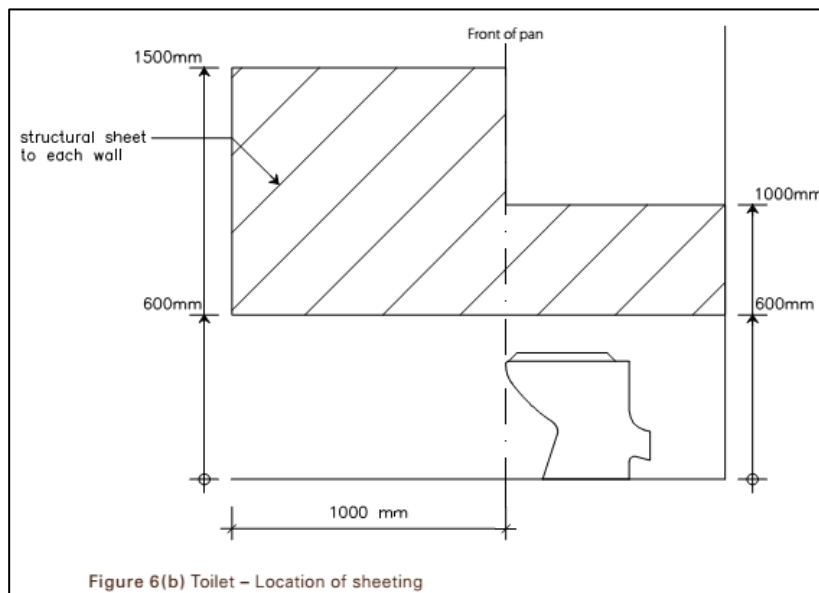
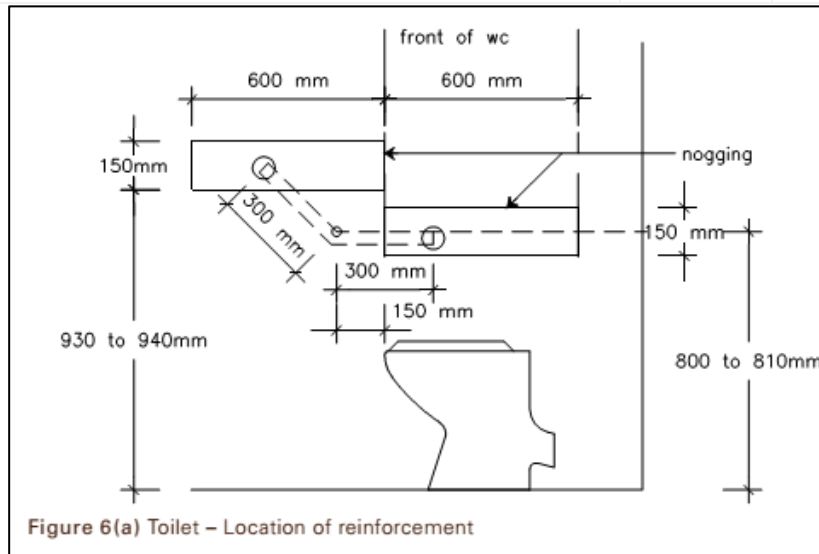

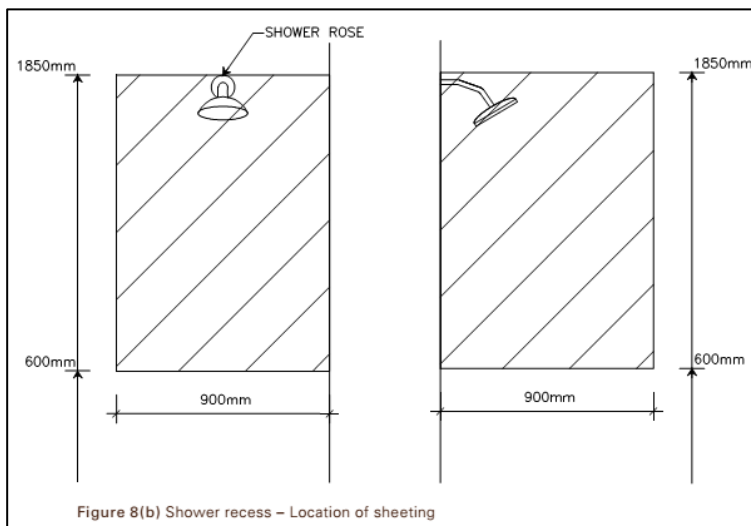
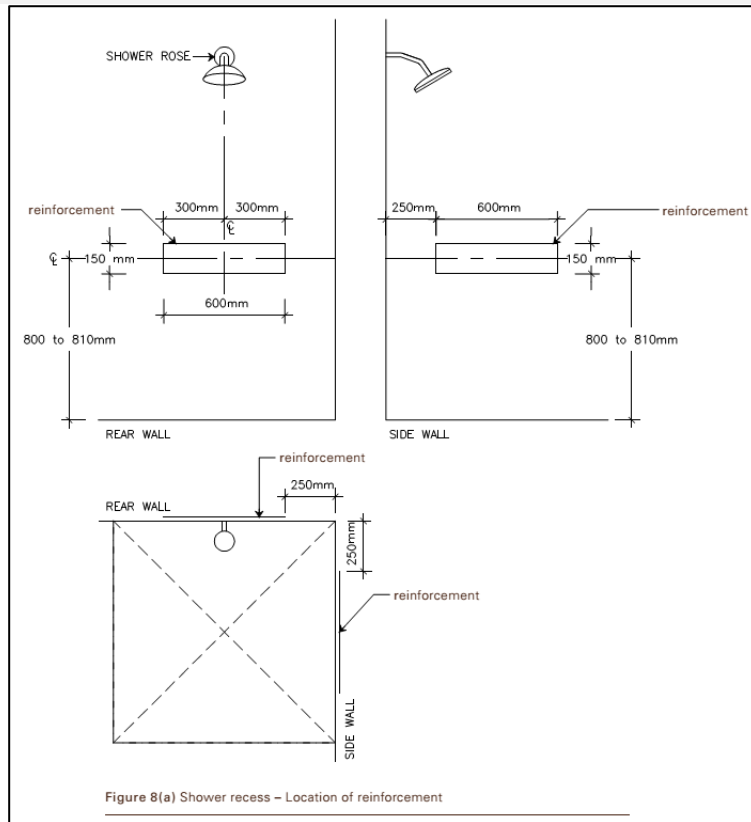

7. Internal stairways

Performance Statement - Where installed, stairways are designed to reduce the likelihood of injury and also enable safety pathway.

	ADR	N/A	C
7.4 Stairways in dwellings must feature a continues handrail on both sides of the stairway.	<input type="checkbox"/>	<input checked="" type="checkbox"/>	<input type="checkbox"/>
7.4 Stairways in dwellings must feature a minimum clear width of 1000mm;	<input type="checkbox"/>	<input checked="" type="checkbox"/>	<input type="checkbox"/>
7.4 Stairways in dwellings must be straight in design; and	<input type="checkbox"/>	<input checked="" type="checkbox"/>	<input type="checkbox"/>
7.4 Stairways in dwellings must be positioned adjoining a load bearing wall.	<input type="checkbox"/>	<input checked="" type="checkbox"/>	<input type="checkbox"/>
7.4 Stairways in dwellings must have closed risers	<input type="checkbox"/>	<input checked="" type="checkbox"/>	<input type="checkbox"/>

7.4 Stairways in dwellings must have minimum landing areas of 1200mm x 1200mm at the top and base of the stairway.	<input type="checkbox"/>	<input checked="" type="checkbox"/>	<input type="checkbox"/>
Note: The steps must provide a slip resistant finish and suitable non-slip tread as specified in the NCC.			
8. Kitchen space <i>Performance Statement - The kitchen space is designed to support ease of movement between fixed benches and to support easy adaptation.</i>	ADR	N/A	C
8.4 The kitchen space should be designed to support ease of movement and adaptation with at least 1550mm clearance in front of fixed benches and appliances (excluding handles); and Notes: Can be compliant at the CC stage	<input type="checkbox"/>	<input type="checkbox"/>	<input checked="" type="checkbox"/>
8.4 Slip resistant flooring to be provided Notes: Can be compliant at the CC stage	<input type="checkbox"/>	<input type="checkbox"/>	<input checked="" type="checkbox"/>
8.4 Floor finishes should extend under kitchen cabinetry to enable cupboards to be removed without affecting the flooring. Where fixtures cannot be easily removed (e.g. ovens which are built in) the floor finishes should not be continued. If relying on advice from a third party, Assessors are advised to provide a note in the comments section. Notes: Can be compliant at the CC stage	<input type="checkbox"/>	<input type="checkbox"/>	<input checked="" type="checkbox"/>
8.4 Task lighting installed above workspaces. Notes: Can be compliant at the CC stage	<input type="checkbox"/>	<input type="checkbox"/>	<input checked="" type="checkbox"/>
9. Laundry space <i>Performance Statement - The laundry space is designed to support ease of movement between fixed benches and to support easy adaptation.</i>	ADR	N/A	C
9.4 The laundry space should be designed to support ease of movement and adaptation with at least 1550mm clear width provided in front of fixed benches and appliances (excluding handles). Where the appliances are not installed then the recessed area provision for an appliance shall be a minimum of 600mm in depth. Notes: Can be compliant at the CC stage	<input type="checkbox"/>	<input type="checkbox"/>	<input checked="" type="checkbox"/>
9.4 Slip resistant flooring to be provided Notes: Can be compliant at the CC stage	<input type="checkbox"/>	<input type="checkbox"/>	<input checked="" type="checkbox"/>
9.4 Floor finishes should extend under laundry cabinetry to enable cupboards to be removed without affecting the flooring. Where fixtures cannot be easily removed the floor finishes should not be continued. If relying on advice from a third party, Assessors are advised to provide a note in the comments section. Notes: Can be compliant at the CC stage	<input type="checkbox"/>	<input type="checkbox"/>	<input checked="" type="checkbox"/>
10. Ground (or entry level) bedroom space <i>Performance Statement - There is a space on the ground (or entry) level that can be used as a bedroom.</i>	ADR	N/A	C
10.4 The dwelling should feature a space (or room) on the ground (or entry) level that is of as of at least 10m ² clearance exclusive of wardrobes; skirtings and wall lining; Notes: Can be compliant at the CC stage	<input type="checkbox"/>	<input type="checkbox"/>	<input checked="" type="checkbox"/>
10.4 Provides a space of at least 1540mm (width) x 2070mm (in the direction of travel) on the side on the bed that is closest to the door approach	<input type="checkbox"/>	<input type="checkbox"/>	<input checked="" type="checkbox"/>

Notes: Can be compliant at the CC stage			
10.4 Provides for a minimum path of travel of 1000mm on the remaining side of the bed Notes: Can be compliant at the CC stage	<input type="checkbox"/>	<input type="checkbox"/>	✓
10.4 Where no bed the design should assume a queen size. Notes: Can be compliant at the CC stage	<input type="checkbox"/>	<input type="checkbox"/>	✓
11. Switches and power points <i>Performance Statement - Light switches and power points are located at heights that are easy to reach for all home occupants.</i>	ADR	N/A	C
11.4 Light switches should be positioned in a consistent location: iii. between 900mm – 1100mm above the finished floor level; and iv. horizontally aligned with the door handle at the entrance to a room. Notes: Can be compliant at the CC stage	<input type="checkbox"/> <input type="checkbox"/>	<input type="checkbox"/> <input type="checkbox"/>	✓ ✓
11.4 Power points should be installed not lower than 300mm above the finished floor level Notes: Can be compliant at the CC stage	<input type="checkbox"/>	<input type="checkbox"/>	✓
11.4 Light and power point switches should be rocker action, toggle or push pad in design with a recommended width of 35mm Notes: Can be compliant at the CC stage	<input type="checkbox"/>	<input type="checkbox"/>	✓
12. Door and tap hardware <i>Performance Statement - Home occupants are able to easily and independently open and close doors and safely use tap hardware.</i>	ADR	N/A	C
12.4 Doorways should feature door hardware installed at between 900mm – 1100mm above the finished floor. Notes: Can be compliant at the CC stage	<input type="checkbox"/>	<input type="checkbox"/>	✓
12.4 Doorways should feature lever or D-pull style door hardware. The handle clearances for D-pull style door hardware should be the same as AS1428.1 2009. AS 1428.1-2009 is the most relevant set of specifications aimed at providing the greatest access to the greatest number of people and as such is an appropriate standard to reference for this Element. Notes: Can be compliant at the CC stage	<input type="checkbox"/>	<input type="checkbox"/>	✓
12.4 Basins, sinks and tubs should feature lever or capstan style tap hardware with a central spout. Notes: Can be compliant at the CC stage	<input type="checkbox"/>	<input type="checkbox"/>	✓
13. Family/living room space <i>Performance Statement - The family/living room features clear space to enable the home occupant to move in and around the room with ease.</i>	ADR	N/A	C
13.4 The family/living room should accommodate a free space, minimum 2250mm in diameter, to enable ease of movement clear of furniture. Notes: Can be compliant at the CC stage	<input type="checkbox"/>	<input type="checkbox"/>	✓
14. Window sills <i>Performance Statement - Windows sills are installed at a height that enables home occupants to view the outdoor space from either a seated or standing position.</i>	ADR	N/A	C

<p>14.4 Window sills on the ground (or entry) level in living areas and bedroom spaces should be positioned no higher than 1000mm above the finished floor level to enable enjoyment of the outlook. Note: A concession from (a) is reasonable in kitchen, bathroom and utility spaces. Notes: Can be compliant at the CC stage</p>	<input type="checkbox"/>	<input type="checkbox"/>	✓
<p>14.4 Window controls should be able to be easy to operate with one hand and located within easy reach from either a seated or standing position. Note: A concession from (a) is reasonable in kitchen, bathroom and utility spaces. Notes: Can be compliant at the CC stage</p>	<input type="checkbox"/>	<input type="checkbox"/>	✓
<p>15. Flooring Performance Statement - Floor coverings are slip resistant to reduce the likelihood of slips, trips and falls in the home.</p>	ADR	N/A	C
<p>15.4 All floor coverings should be firm, even and slip resistant; and Notes: Can be compliant at the CC stage</p>	<input type="checkbox"/>	<input type="checkbox"/>	✓
<p>15.4 All flooring should feature a level transition between abutting surfaces (a maximum vertical tolerance of 5mm between abutting surfaces is allowable provided the lip is rounded or beveled). Notes: Can be compliant at the CC stage</p>	<input type="checkbox"/>	<input type="checkbox"/>	✓

DISABILITY DISCRIMINATION ACT

Advisory Only

The Disability Discrimination Act (1992) (DDA) protects everyone in Australia against discrimination based on disabilities ranging from, but not limited to mobility, sensory and cognitive disabilities. There is no doubt that the introduction of the Premises Standards has led to widespread and important improvements in the accessibility world and safety of all new and upgraded public buildings in Australia.

Section 32 of the DDA makes it unlawful to contravene a provision of a disability standard & the persons responsible who fail to address the 'affected part' requirements when triggered for a building could be subject to a complaint under the DDA as a result.

If there is a difference between the technical requirements of the Access Code and any document referenced in the Access Code, including Australian Standards, the Access Code takes precedence.

The basic trigger for the application of the Premises Standards is when any building work is undertaken that requires building/construction approval. A building certifier, building developer or building manager of a relevant building must ensure that the building complies with the Access to Premises Standards.

The scope of the DDA also includes the area of the room measured within the finished surfaces of the walls and includes the area occupied by any cupboard or other built-in furniture, fixture, or fittings.

The scope of DDA extends beyond the building fabric and includes furniture and fittings. We cannot guarantee or certify DDA compliance because DDA compliance can only be assessed by the court.

People Helping People - PHP



People Helping People, “PHP” is a video interview series hosted by Rami Shakour, founder of Access Link Consulting. The series centers around the vital role of accessibility in enhancing community development and enabling individual independence.

Through enlightening conversations, each episode uncovers how creating accessible environments is not just about compliance with standards, but about fundamentally enhancing people's lives, enabling them to engage fully with their communities and live more independently.

The series features a diverse lineup of guests, including professionals from the fields of construction, architecture, NDIS, as well as individuals who share their personal experiences and the tangible impacts of accessible design. Our conversations delve into innovative solutions and obstacles faced by those working to make our world more accessible, offering insights and inspiration for all listeners. As we explore the stories of individuals from different industry sectors and walks of life, we aim to shed light on the people who are impacting and transforming lives and contributing to a more inclusive community.

Visit our YouTube channel to view our latest interviews.

www.youtube.com/@accesslinkconsulting

Accreditations

“Access Link Consulting was founded to fill a gap in the construction and modern accessibility industry and provide innovation, efficient solutions and proactivity.” – Rami Shakour / Founder



iCIRT

Access Link Consulting is proudly the first access consultancy firm to achieve the esteemed 4-Gold Star iCIRT Rating. The iCIRT Accreditation serves as a testament to our unwavering commitment to professionalism and performance, allowing clients and stakeholders to place their trust in us as a company that upholds the highest standards.



ISO 9001

Quality Management ensures that our processes are structured for efficiency, consistency and continual improvement. It guarantees that our clients receive high-quality, tailored accessibility solutions that meet regulatory requirements and industry best practices.



ISO 45001

Occupational Health & Safety demonstrates our commitment to implementing rigorous health and safety protocols, mitigating workplace risks and fostering a secure environment for our team, clients and stakeholders, ensuring the highest standards of occupational well-being.



ISO 14001

Environmental Management highlights our commitment to environmental management allowing us to minimise our ecological impact and continue to implement sustainable practices throughout our operations.

Partnerships



- Sponsor & Exclusive Consultancy Partner

Zero Barriers

At Access Link Consulting, our commitment to building inclusive communities shines through our partnership with Zero Barriers, a project by The Multicultural Network. As the exclusive Access Consultancy partner, we combine our accessibility expertise with Zero Barriers' practical community engagement approach. Together, we help businesses adopt inclusive practices, transforming accessibility into a reality for everyone.



SDA Alliance Supporter

Access Link Consulting proudly collaborates with The Specialist Disability Accommodation (SDA) Alliance, dedicated to enhancing SDA across sectors. This partnership brings our accessibility expertise to the forefront of SDA projects. Through advocacy, innovation, and shared values, we aim to create inclusive living environments for people with disabilities, supported by regular collaboration with other providers.



Trademark

Trademark Group is an Australian conglomerate operating in construction, development, and industrial manufacturing. It focuses on fostering collaboration, sharing expertise, and creating cross-border opportunities between Australia, the Kingdom of Saudi Arabia, and the broader GCC region. Access Link Consulting is a proud member of Trademark Group, gaining access to a global network of collaboration and opportunity.

Meet Our Team



Access Link Consulting extends beyond Australia's disability standards for access to premises. We aspire to create a world where dignified and seamless movement is a reality for all, surpassing compliance to achieve comprehensive accessibility solutions for the community.



Rami Shakour

Director

B. Architecture | M.P.M in Construction | Dip. Access Consulting | ACA Accredited Access Consultant | LHA/NCC Accredited Assessor | NDIS Accredited SDA Assessor | Changing Places Assessor

Rami Shakour is the founder and director of Access Link Consulting. With a remarkable track record spanning over 9 years in the accessibility, architecture, and construction industries, Rami brings an unparalleled wealth of expertise to his role as the leader of our consultation services for seamless accessibility facilities.

With Rami's specialised knowledge and forward-thinking approach, Access Link Consulting is uniquely positioned to offer consultation on innovative solutions across residential, commercial, industrial, and mixed-use developments as well as public and private open spaces. By delivering these services, we aim to advance an inclusive and accessible future for all.

Rami holds a Bachelor of Architecture, a Master of Project Management and a Diploma of Access Consulting. In addition to this, Rami is also an Accredited Access Consultant with Association of Consultants in Access Australia (ACAA), National Disability Insurance Scheme (NDIS) Accredited SDA Assessor, LHA/NCC Assessor and Changing Places Assessor.



Tony Walker

Senior Manager

B.LArch (Hons) | Dip. Access Consulting

Tony has developed extensive skills in the planning, design, construction, and management of public open spaces across urban, suburban, and natural landscapes. Previously as the Manager of Fairfield Place and Public Domain Planning for Fairfield City Council and Place Manager East for Parramatta City Council, Tony also developed impressive and outstanding complementary strategic place management and place making project management skills along with valuable community consultation and collaboration experience.

As a Senior Manager, Tony holds a Bachelor of Landscape Architecture (Hons), Dip. Access Consulting, Assoc. Dip. Environmental Control, and a Cert II Horticulture.

With a wealth of qualifications and an extensive skillset cultivated over numerous years of experience in the landscape construction and local government sectors, Tony brings invaluable expertise to Access Link Consulting. His commitment to delivering DDA-compliant outcomes stems from a place-based and community-oriented approach.

Tony's Vision is that public communal spaces which have involved Access Link Consulting, support the provision of dignified and inclusive access to all facilities and amenities including enriching place-based experiences.





Jessica Bechara

Access Consultant

Dip. Business Management | Cert. IV in Access Consulting | ACA Associate Access Consultant

As an experienced Consultant with a wealth of industry insight and experience, Jessica works collaboratively with accredited certifiers, developers, builders and individuals bringing a thorough understanding of both the construction and consultancy realms.

Jessica's expertise encompasses BCA & Access reviews, where she excels in assisting clients in achieving their project goals, from Development Applications to Occupational Certificates. Jessica holds a Certificate IV in Access Consultancy and has over six years' experience in the construction industry. Her extensive experience and first-hand knowledge in accessibility allow her to skillfully coordinate between architects, planners, and developers.

Jessica's dedication to excellence ensures that she delivers quality services to all clients, guided by a vision of accessibility that meets both current and future needs.



Tshkhoun Kechebashian

Account Manager

B. Economics in Management & Accounting | Cert. IV in Bookkeeping

Tshkhoun holds a Certificate IV in Bookkeeping and has extensive work experience, mostly in in-house accounts and administration, including experience in industrial companies.

Her career boasts a diverse range of roles, from General Accounting to Industrial Cost accounting and Human Resources, making Tshkhoun a crucial asset in the day-to-day management of the company. Notably, her involvement in various operational departments and her training in documentation and internal auditing for ISO standards have been pivotal in shaping her career at Access Link.

Drawing from her prior experience in customer service-related positions, Tshkhoun possesses exceptional problem-solving and communication skills, which play a vital role in the seamless management of accounts and related matters.

Tshkhoun considers her customer service experience, bookkeeping and accounting skills and administration expertise a big asset in her career journey.



www.accesslink.com.au

02 7232 0808 | contact@accesslink.com.au

Level 1, Suite 3, 117 Harris St, Pyrmont NSW 2009

P.O Box 123, Gosford NSW 2250

ACCESS LINK
CONSULTING

