



PEDESTRIAN WIND ENVIRONMENT STATEMENT

2 FISHBURN CRESCENT, CASTLE HILL (LOT 1 DP 1316896)

WJ274-06F02(REV0)- WS REPORT

SEPTEMBER 9, 2025

Prepared for:

ARADA MANAGEMENT SERVICES PTY LTD

12 Harvey Street, Pyrmont, NSW, 2009

AT THE LEADING EDGE

WINDTECH CONSULTANTS

www.windtechconsult.com

reception@windtechglobal.com

DOCUMENT CONTROL

Date	Revision History	Issued Revision	Prepared By (initials)	Instructed By (initials)	Reviewed & Authorised by (initials)
September 9, 2025	Initial.	0	CT	MM	TH

The work presented in this document was carried out in accordance with the Windtech Consultants Quality Assurance System, which is based on International Standard ISO 9001.

This document is issued subject to review and authorisation by the Team Leader noted by the initials printed in the last column above. If no initials appear, this document shall be considered as preliminary or draft only and no reliance shall be placed upon it other than for information to be verified later.

This document is prepared for our Client's particular requirements which are based on a specific brief with limitations as agreed to with the Client. It is not intended for and should not be relied upon by a third party and no responsibility is undertaken to any third party without prior consent provided by Windtech Consultants. The information herein should not be reproduced, presented or reviewed except in full. Prior to passing on to a third party, the Client is to fully inform the third party of the specific brief and limitations associated with the commission.

EXECUTIVE SUMMARY

This report presents an opinion on the likely impact of the development located 2 Fishburn Crescent, Castle Hill (Lot 1 DP 1316896), on the local wind environment at the critical outdoor areas within and around the subject site. The effect of wind activity has been examined for the three predominant wind directions for the region, namely the north-easterly, south to south-easterly and westerly winds. The analysis of the wind effects relating to the proposed development have been carried out in the context of the local wind climate, building morphology and land topography.

The conclusions of this report are drawn from our extensive experience in this field and are based on an examination of the latest architectural drawings. No wind tunnel testing has been undertaken for the subject development, and hence this report addresses only the general wind effects and any localised effects that are identifiable by visual inspection of the architectural drawings provided (received September 1, 2025). Any recommendations in this report are made only in-principle and are based on our extensive experience in the study of wind environment effects.

The results of this assessment indicate that the development has incorporated several design features and wind mitigating strategies and is expected to be suitable for the intended use for the majority of the outdoor trafficable areas. However, there are some areas that are likely to be exposed to stronger winds. It is expected that the wind effects identified in the report can be ameliorated with the consideration of the following treatment strategies into the design of the development:

Local Ground Level Areas (Lower Ground, Ground and Upper Ground Levels):

- Retention the proposed trees throughout the development (including the central courtyard), ensuring that the trees are of an evergreen and densely foliating species capable of growing to a height of at least 3-5m, with 3-5m wide canopies.
- Retention of the proposed porous screening surrounding the communal outdoor pool.
- Retention of the proposed impermeable awning structures above the communal outdoor table settings.
- Retention of the proposed set-back nature of the building envelope from the surrounding footpath areas to ensure minimal impact of the subject development on the surrounding public domain.
- Retention of the proposed set-back nature of the building lobby/foyer entrances to ensure that the entrance zones are shielded from the effects of the prevailing winds.
- Consider the inclusion of effective wind mitigation features within the communal courtyard, such as localised free-standing screening or densely foliating evergreen vegetation. In particular around outdoor areas intended for short and/or long-term stationary activities.

Communal Open Spaces:

- Level 7 – The inclusion of the following:
 - Inclusion of 1.5-1.8m high densely foliating and evergreen hedges/shrubs within the proposed planter areas where possible.
 - Retention of the 1.8m high proposed balustrades along the exposed perimeters of the communal open space located at the western end of Building B.
- Level 10 – The inclusion of the following:
 - Inclusion of 1.5-1.8m high densely foliating and evergreen hedges/shrubs within the proposed planter areas where possible.
 - Retention of the 1.8m high proposed balustrades along the exposed perimeters of the communal open space located at the western end of Building C.
 - Retention of the proposed two pergola structures, ensuring that their porosity does not exceed 40%.
- Level 18 (Building A Roof) – The inclusion of the following:
 - Inclusion of 1.5-1.8m high densely foliating and evergreen hedges/shrubs within the proposed planter areas where possible.
 - Retention of the 1.8m high proposed balustrades along the exposed perimeters of the communal open space located on the Level 18 (Building A Roof).
 - Retention of the proposed AWN3 structures, ensuring that their porosity does not exceed 40%.

Private Outdoor Terraces:

- Level 7 – The inclusion of the following:
 - Retention of the 1.8m high proposed balustrades along the exposed perimeters of the two larger balconies located at the southern end of Building B.
- Level 13 – The inclusion of the following:
 - Retention of the 1.8m high proposed balustrades along the exposed perimeters of the two terraces located at Level 13 of Building B.
 - Retention of the proposed balcony and AWN3 structures, ensuring that the porosity of the AWN3 does not exceed 40%.
- Level 14 – The inclusion of the following:
 - Retention of the 1.8m high proposed balustrades along the exposed perimeters of the two terraces located at Level 14 of Building A
 - Retention of the proposed two AWN3 structures, ensuring that their porosity does not exceed 40%.
- Level 16 – The inclusion of the following:
 - Retention of the 1.8m high proposed balustrades along the exposed perimeters of the terrace located at Level 16 of Building B.
 - Retention of the proposed AWN4 structure, ensuring that their porosity does not exceed 40%.

Private Balconies:

- Building A
 - The proposed balustrades along the Level 15 to Level 17 eastern perimeter edge of the south-eastern private balcony, as indicated in the architectural drawings, is to be raised in height to 1.8m above the finish floor level.
- Building B
 - The proposed balustrades along the Level 01 to Level 03 and Level 08 to Level 10 western perimeter edge of the south-western private balcony, as indicated in the architectural drawings, is to be raised in height to 1.5m above the finish floor level.
 - The proposed balustrades along the Level 11 to Level 12 and Level 14 to Level 15 western perimeter edge of the south-western private balcony, as indicated in the architectural drawings, is to be raised in height to 1.8m above the finish floor level.
 - The proposed balustrades along the Level 14 to Level 15 southern perimeter edge of the western private balcony, as indicated in the architectural drawings, is to be raised in height to 1.8m above the finish floor level.
- Building C
 - The proposed balustrades along the Level 01 to Level 09 western perimeter edge of the south-western private balcony, as indicated in the architectural drawings, is to be raised in height to 1.5m above the finish floor level.
- Retention of the proposed standard height balustrades along the remaining perimeters of the private balconies.

With the inclusion of the abovementioned recommendations in the final design, it is expected that the wind conditions for the various trafficable outdoor areas within and around the development will be suitable for their intended uses, and that the wind speeds will satisfy the applicable criteria for pedestrian comfort and safety.

In particular, the wind conditions within the public footpaths surrounding the subject development are expected to be suitable for walking activities, and with the inclusion of the recommended treatment measures, the wind conditions within the building entrance zones as well as the communal open spaces and the private outdoor terraces are expected to satisfy the standing criterion. With the recommended treatments, the wind conditions within the various private balconies are expected to be suitable for standing activities.

Wind tunnel testing is recommended to be undertaken at a more detailed design stage to quantitatively assess the wind conditions and to optimise the size and extent of the treatments.

CONTENTS

2	Description of Development and Surroundings	2
3	Regional Wind	4
4	Wind Effects on People	5
5	Results and Discussion	6
	5.1 Ground Level Trafficable Areas and Pedestrian Footpaths	7
	5.2 Private Outdoor Terraces and Communal Open Spaces	8
	5.3 Private Balconies	10
	5.4 Concluding Remarks	11
6	References	32

Appendix A Wind Effects Glossary

Appendix B List of Architectural Drawings referenced

INTRODUCTION

An opinion on the likely impact of the proposed design on the local wind environment affecting pedestrians within the critical outdoor areas within and around the subject development is presented in this report. The analysis of wind effects relating to the proposed development has been carried out in the context of the predominant wind directions for the region, building morphology of the development and nearby buildings, and local land topography. The conclusions of this report are drawn from our extensive experience in the field of wind engineering and studies of wind environment effects.

No wind tunnel testing has been undertaken for this assessment. Hence this report addresses only the general wind effects and any localised effects that are identifiable by visual inspection of the drawings provided (refer to Appendix B), and any recommendations in this report are made only in-principle.

DESCRIPTION OF DEVELOPMENT AND SURROUNDINGS

The site is located at 2 Fishburn Crescent, Castle Hill (Lot 1 DP 1316896), and is bounded by Carrington Road to the north, Middleton Avenue to the west, Fishburn Crescent to the south, and both Sexton Avenue and low-rise residential buildings to the east. The buildings surrounding the subject development are predominately low-rise residential and commercial buildings, with a few mid-rise residential buildings in the vicinity, and Castle Hill Showground to the north-west. Additionally, the site is neighbouring developments to the east that are approved and under construction.

A survey of the land topography indicates a gradual upward slope towards the east and north throughout the site and in the area immediately surrounding the site.

An aerial image of the subject site and the local surroundings is shown in Figure 1, with the frequency and magnitude of the prevailing winds is superimposed for each wind direction.

The existing site consists of 1-2 storey residential buildings. The proposed development is 20 storeys high.

The critical outdoor trafficable areas associated with the proposed development, which are the focus of this assessment with regards to wind effects, are listed as follows:

- Local Ground Level Areas (Lower Ground, Ground and Upper Ground Levels):
- Communal Open Spaces (Levels 07, 10 and Level 18 – Building A Roof).
- Private Open Terraces (Levels 07, 13, 14, Level 16).
- Private Balconies.



Figure 1: Aerial Image of the Site Location and Prevailing Wind Directions

3 REGIONAL WIND

The Castle Hill region is governed by three principal wind directions that can potentially affect the subject development. These winds prevail from the north-east, south to south-east and west. These wind directions were determined from an analysis undertaken by Windtech Consultants of recorded directional wind speeds obtained from the meteorological station located at Bankstown Airport by the Bureau of Meteorology (recorded from 1993 to 2016). The data has been corrected to represent winds over standard open terrain at a height of 10m above ground level. The results of this analysis are presented in Figure 2 in the form of a directional plot of the annual and 5% exceedance mean winds for the region. The frequency of occurrence of these winds is also shown in Figure 2.

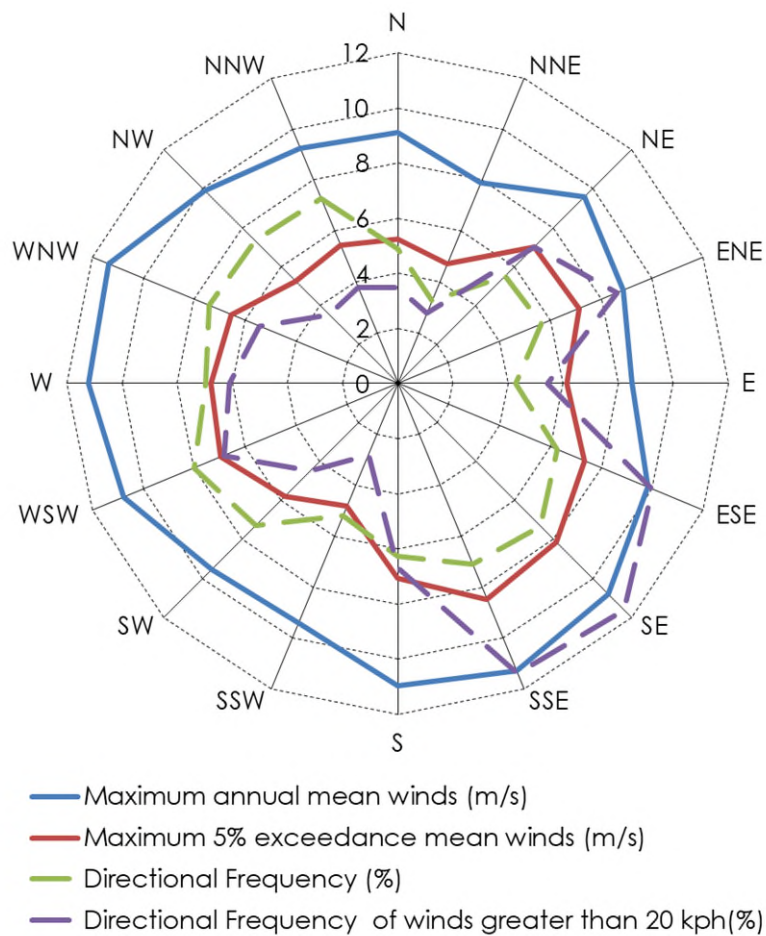

Figure 2: Directional Annual and 5% Exceedance Hourly Mean Wind Speeds (referenced to 10m height in standard open terrain), and Frequencies of Occurrence, for the Castle Hill Region

4 WIND EFFECTS ON PEOPLE

The acceptability of wind in any area is dependent upon its use. For example, people walking, or window-shopping will tolerate higher wind speeds than those seated at an outdoor restaurant. Various other researchers, such as A.G. Davenport, T.V. Lawson, W.H. Melbourne, and A.D. Penwarden, have published criteria for pedestrian comfort for pedestrians in outdoor spaces for various types of activities. Some Councils and Local Government Authorities have adopted elements of some of these into their planning control requirements.

For example, A.D. Penwarden (1973) developed a modified version of the Beaufort scale which describes the effects of various wind intensities on people. Table 1 presents the modified Beaufort scale. Note that the effects listed in this table refers to wind conditions occurring frequently over the averaging time (a probability of occurrence exceeding 5%). Higher ranges of wind speeds can be tolerated for rarer events.

Table 1: Summary of Wind Effects on People (A.D. Penwarden, 1973)

Type of Winds	Beaufort Number	Mean Wind Speed (m/s)	Effects
Calm	0	Less than 0.3	Negligible.
Calm, light air	1	0.3 – 1.6	No noticeable wind.
Light breeze	2	1.6 – 3.4	Wind felt on face.
Gentle breeze	3	3.4 – 5.5	Hair is disturbed, clothing flaps, newspapers difficult to read.
Moderate breeze	4	5.5 – 8.0	Raises dust, dry soil and loose paper, hair disarranged.
Fresh breeze	5	8.0 – 10.8	Force of wind felt on body, danger of stumbling
Strong breeze	6	10.8 – 13.9	Umbrellas used with difficulty, hair blown straight, difficult to walk steadily, wind noise on ears unpleasant.
Near gale	7	13.9 – 17.2	Inconvenience felt when walking.
Gale	8	17.2 – 20.8	Generally impedes progress, difficulty balancing in gusts.
Strong gale	9	Greater than 20.8	People blown over.

It should be noted that wind speeds affecting this particular development can only be accurately quantified with a wind tunnel study. This assessment addresses only the general wind effects and any localised effects that are identifiable by visual inspection and the acceptability of the conditions for outdoor areas are determined based on their intended use. Any recommendations in this report are made only in-principle and are based on our extensive experience in the study of wind environment effects.

RESULTS AND DISCUSSION

The expected wind conditions affecting the development are discussed in the following sub-sections of this report for the various outdoor areas within and around the subject development. The interaction between the wind and the building morphology in the area is considered and important features taken into account including the distances between the surrounding buildings and the proposed building form, as well as the surrounding landform. Note that only the potentially critical wind effects are discussed in this report. A glossary of the different wind effects described in this report included in Appendix A.

For this assessment, the wind speed criteria for pedestrian comfort that are considered are listed as follows:

- Walking Criterion (8m/s with a 5% probability of exceedance)
for general circulation and pedestrian thoroughfares, e.g. footpaths, private balconies/terraces, through-site links etc.
- Standing (Short Exposure) Criterion (6m/s with a 5% probability of exceedance)
for stationary activities generally less than an hour, e.g. waiting areas, communal terraces, main entries, café seating etc.
- Sitting (Long Exposure) (4m/s with a 5% probability of exceedance)
for stationary activities longer than an hour, e.g. outdoor cinemas, outdoor fine dining etc.

Note that the above wind comfort levels are derived from the Lawson (1975) criteria. Although this assessment is qualitative in nature, the abovementioned criteria for pedestrian comfort are considered when assessing the wind environment impacts. However, all areas are also assessed with consideration to a pedestrian safety criterion of 23m/s for the annual maximum gust.

5.1 Ground Level Trafficable Areas and Pedestrian Footpaths

The subject building massing is set-back significantly from all the pedestrian footpaths surrounding the site (i.e. pedestrian footpaths along the Carrington Road, Middleton Avenue, Fishburn Crescent and Sexton Avenue), and hence the inclusion of the proposed development within this site is not expected to alter the existing wind flow patterns within these footpaths.

Furthermore, given the location and orientation of the various buildings of the subject development in relation to the prevailing winds and their strength/frequency of occurrence, the wind conditions within various pedestrian trafficable areas within and around the site at the Ground Level are expected to satisfy the safety wind criteria. However, the wind effects caused by the interaction of the prevailing winds with the various facades, through-site links (i.e. walkways between Building A, B and C) and the central courtyard are expected to cause comfort exceedances.

In this regard, the north-easterly winds will have direct impact on the north-eastern corner of Building B (NE building) where the lobby entrance is located. These winds will also likely side stream along the northern and eastern façades of Building B. The north-easterly winds will also likely cause direct and side-streaming effects on the eastern façade of Building C, which will likely result corner acceleration effects around the south-eastern corner. Building A and the central courtyard are mostly protected from the north-easterly winds by the Building B massing. The south-easterly prevailing winds are expected to funnel through the space between Buildings B and C, and circulate around the central courtyard, while also travelling along the gaps between Building A and B, as well as Buildings A and C. The south-easterly winds will also have direct impacts and side-streaming off the southern and eastern façades of Building C. These winds may also down-wash off the southern façade of Building C onto the areas located directly underneath. The westerly winds are expected to have direct impact on the western aspects of Buildings A and C, while these winds may also down-wash off the respective western facades onto the areas located directly underneath. The westerly winds will also likely funnel between the through-site link between Buildings A and C. All these wind effects can be ameliorated with strategic inclusion of densely foliating vegetations within and around the site and free standing-screening. Proposed seating areas that are intended for longer stationary durations, are to include an impermeable awning structure and localised densely foliating vegetation to ensure that sitting comfort is achieved.

Furthermore, it is worth noting that the various building lobby entrances are either facing away from prevailing winds and/or set-back into the building form (due to the design of the envelope or due to their location in between wide columns) and hence the areas immediately outside of the lobby areas are expected to be suitable for standing activities.

The following treatment measures are recommended to be included in the design to ensure safe and comfortable wind conditions within and around the ground plane of the proposed development.

Local Ground Level Areas (Lower Ground, Ground and Upper Ground Levels)– Figures 3:

- Retention the proposed trees throughout the development (including the central courtyard), ensuring that the trees are of an evergreen and densely foliating species capable of growing to a height of at least 3-5m, with 3-5m wide canopies.
- Retention of the proposed porous screening surrounding the communal outdoor pool.
- Retention of the proposed impermeable awning structures above the communal outdoor table areas.
- Retention of the proposed set-back nature of the building envelope from the surrounding footpath areas to ensure minimal impact of the subject development on the surrounding public domain.
- Retention of the proposed set-back nature of the building lobby/foyer entrances to ensure that the entrance zones are shielded from the effects of the prevailing winds.
- Consider the inclusion of effective wind mitigation features within the communal courtyard, such as localised free-standing screening or densely foliating evergreen vegetation. In particular around outdoor areas intended for short and/or long-term stationary activities.

5.2 Private Outdoor Terraces and Communal Open Spaces

The subject development consists of large private open terraces at Levels 7, 13, 14 and 16, as well as communal open spaces at Levels 07, 10 and 18 (Building A Roof). Given the relatively higher height of the subject development in relation to the neighbouring buildings, these elevated pedestrian trafficable areas are generally exposed to at least two of the prevailing winds which can result in direct and/or side steaming winds which can also accelerate around the various corners.

The following treatment measures are recommended to be included in the design to ensure safe and comfortable wind conditions within various private outdoor terraces and communal open spaces of the proposed development.

Communal Open Spaces – Figures 3:

- Level 7 – The inclusion of the following:
 - Inclusion of 1.5-1.8m high densely foliating and evergreen hedges/shrubs within the proposed planter areas where possible.
 - Retention of the 1.8m high proposed balustrades along the exposed perimeters of the communal open space located at the western end of Building B.
- Level 10 – The inclusion of the following:
 - Inclusion of 1.5-1.8m high densely foliating and evergreen hedges/shrubs within the proposed planter areas where possible.
 - Retention of the 1.8m high proposed balustrades along the exposed perimeters of the communal open space located at the western end of Building C.
 - Retention of the proposed two pergola structures, ensuring that their porosity does not exceed 40%.

- Level 18 (Building A Roof) – The inclusion of the following:
 - Inclusion of 1.5-1.8m high densely foliating and evergreen hedges/shrubs within the proposed planter areas where possible.
 - Retention of the 1.8m high proposed balustrades along the exposed perimeters of the communal open space located on the Level 18 (Building A Roof).
 - Retention of the proposed AWN3 structures, ensuring that their porosity does not exceed 40%.

Private Outdoor Terraces – Figures 3:

- Level 7 – The inclusion of the following:
 - Retention of the 1.8m high proposed balustrades along the exposed perimeters of the two larger balconies located at the southern end of Building B.
- Level 13 – The inclusion of the following:
 - Retention of the 1.8m high proposed balustrades along the exposed perimeters of the two terraces located at Level 13 of Building B.
 - Retention of the proposed balcony and AWN3 structures, ensuring that the porosity of the AWN3 does not exceed 40%.
- Level 14 – The inclusion of the following:
 - Retention of the 1.8m high proposed balustrades along the exposed perimeters of the two terraces located at Level 14 of Building A
 - Retention of the proposed two AWN3 structures, ensuring that their porosity does not exceed 40%.
- Level 16 – The inclusion of the following:
 - Retention of the 1.8m high proposed balustrades along the exposed perimeters of the terrace located at Level 16 of Building B.
 - Retention of the proposed AWN4 structure, ensuring that their porosity does not exceed 40%.

5.3 Private Balconies

The majority of the private balconies of the development benefit from the inclusion of various wind mitigation features such as their overall recessed design, balustrades, and blade-walls/end-screens. These features should be retained in the final design. However, the prevailing winds have the potential to travel through the various corner balconies, which can cause undesirable wind conditions due to side-streaming and corner acceleration effects, especially within the upper levels.

The following treatment measures are recommended to be included in the design to ensure safe and comfortable wind conditions within the various private balconies of the proposed development.

Private Balconies – Figures 3:

- Building A
 - The proposed balustrades along the Level 15 to Level 17 eastern perimeter edge of the south-eastern private balcony, as indicated in the architectural drawings, is to be raised in height to 1.8m above the finish floor level.
- Building B
 - The proposed balustrades along the Level 01 to Level 03 and Level 08 to Level 10 western perimeter edge of the south-western private balcony, as indicated in the architectural drawings, is to be raised in height to 1.5m above the finish floor level.
 - The proposed balustrades along the Level 11 to Level 12 and Level 14 to Level 15 western perimeter edge of the south-western private balcony, as indicated in the architectural drawings, is to be raised in height to 1.8m above the finish floor level.
 - The proposed balustrades along the Level 14 to Level 15 southern perimeter edge of the western private balcony, as indicated in the architectural drawings, is to be raised in height to 1.8m above the finish floor level.
- Building C
 - The proposed balustrades along the Level 01 to Level 09 western perimeter edge of the south-western private balcony, as indicated in the architectural drawings, is to be raised in height to 1.5m above the finish floor level.
- Retention of the proposed standard height balustrades along the remaining perimeters of the private balconies.

5.4 Concluding Remarks

With the inclusion of the abovementioned recommendations in the final design, it is expected that the wind conditions for the various trafficable outdoor areas within and around the development will be suitable for their intended uses, and that the wind speeds will satisfy the applicable criteria for pedestrian comfort and safety.

In particular, the wind conditions within the public footpaths surrounding the subject development are expected to be suitable for walking activities, and with the inclusion of the recommended treatment measures, the wind conditions within the building entrance zones as well as the communal open spaces and the private outdoor terraces are expected to satisfy the standing criterion. With the recommended treatments, the wind conditions within the various private balconies are expected to be suitable for standing activities.

Wind tunnel testing is recommended to be undertaken at a more detailed design stage to quantitatively assess the wind conditions and to optimise the size and extent of the treatments.

Treatments Legend



Retention of the proposed trees, ensuring that the trees are of an evergreen and densely foliating species, capable of growing to a height of at least 3-5m, with 3-5m wide canopies.





Note: The locations of the trees can be moved slightly to align with future landscape plans, however these zones and tree heights are recommended to be considered. Trees may be replaced with 2m high densely foliating and evergreen hedges/shrubs where preferred.



Figure 3a: Recommended Treatment for the Ground Level

Treatments Legend

 The proposed balustrades, as indicated in the architectural drawings, are to be raised to a height of 1.5m.

 Retention of the proposed trees, ensuring that the trees are of an evergreen and densely foliating species, capable of growing to a height of at least 3-5m, with 3-5m wide canopies.

Note: The locations of the trees can be moved slightly to align with future landscape plans, however these zones and tree heights are recommended to be considered. Trees may be replaced with 2m high densely foliating and evergreen hedges/shrubs where preferred.



Figure 3b: Recommended Treatment for the Upper Ground Level

Treatments Legend

 The proposed balustrades, as indicated in the architectural drawings, are to be raised to a height of 1.5m.



Figure 3c: Recommended Treatment for Level 01

Treatments Legend

 The proposed balustrades, as indicated in the architectural drawings, are to be raised to a height of 1.5m.



Figure 3d: Recommended Treatment for Level 02

Treatments Legend

 The proposed balustrades, as indicated in the architectural drawings, are to be raised to a height of 1.5m.



Figure 3e: Recommended Treatment for Level 03

Treatments Legend

 The proposed balustrades, as indicated in the architectural drawings, are to be raised to a height of 1.5m.



Figure 3f: Recommended Treatment for Level 04

Treatments Legend

 The proposed balustrades, as indicated in the architectural drawings, are to be raised to a height of 1.5m.



Figure 3g: Recommended Treatment for Level 05

Treatments Legend

 The proposed balustrades, as indicated in the architectural drawings, are to be raised to a height of 1.5m.



Figure 3h: Recommended Treatment for Level 06

Treatments Legend

 The proposed balustrades, as indicated in the architectural drawings, are to be raised to a height of 1.5m.



Figure 3j: Recommended Treatment for Level 08

Treatments Legend

 The proposed balustrades, as indicated in the architectural drawings, are to be raised to a height of 1.5m.



Figure 3k: Recommended Treatment for Level 09

Treatments Legend



-  The proposed balustrades, as indicated in the architectural drawings, are to be raised to a height of 1.5m.
-  Inclusion of 1.5-1.8m high densely foliating evergreen hedges/shrubs within the proposed planter boxes.
-  Retention of the proposed pergola structure, as indicated in the architectural drawings, ensuring its porosity does not exceed 40%.



Figure 3l: Recommended Treatment for Level 10

Treatments Legend

 The proposed balustrades, as indicated in the architectural drawings, are to be raised to a height of 1.8m.



Figure 3m: Recommended Treatment for Level 11

Treatments Legend

 The proposed balustrades, as indicated in the architectural drawings, are to be raised to a height of 1.8m.



Figure 3n: Recommended Treatment for Level 12

Treatments Legend

-  Retention of the proposed AWN3 structure, as indicated in the architectural drawings, ensuring its porosity does not exceed 40%.



Figure 30: Recommended Treatment for Level 13

Treatments Legend

- █ The proposed balustrades, as indicated in the architectural drawings, are to be raised to a height of 1.8m.
- █ Retention of the proposed AWN3 structure, as indicated in the architectural drawings, ensuring its porosity does not exceed 40%.



Figure 3p: Recommended Treatment for Level 14

Treatments Legend

 The proposed balustrades, as indicated in the architectural drawings, are to be raised to a height of 1.8m.

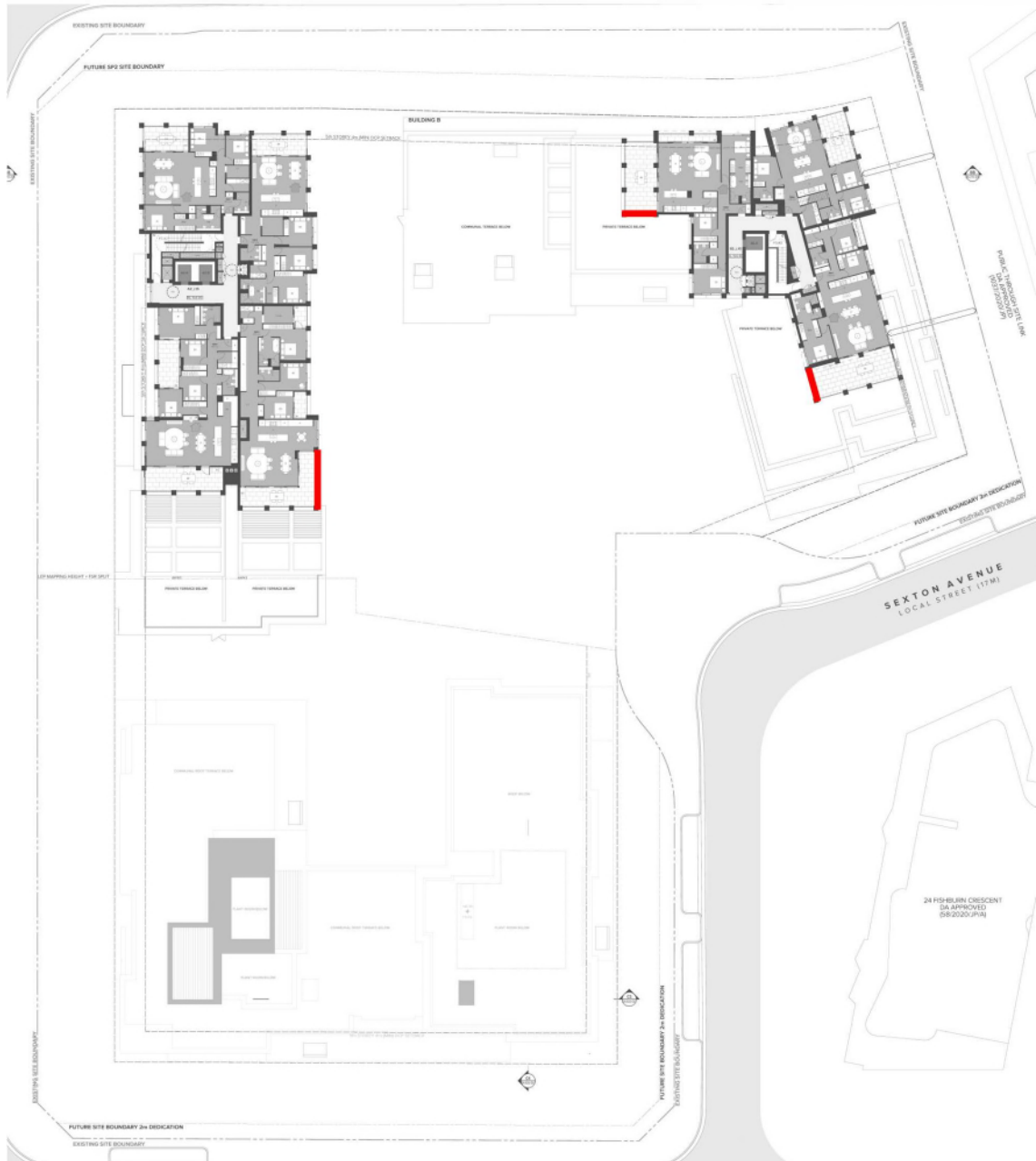

Figure 3q: Recommended Treatment for Level 15

Treatments Legend



-  The proposed balustrades, as indicated in the architectural drawings, are to be raised to a height of 1.8m.
-  Retention of the proposed AWN4 structure, as indicated in the architectural drawings, ensuring its porosity does not exceed 40%.



Figure 3r: Recommended Treatment for Level 16

Treatments Legend

 The proposed balustrades, as indicated in the architectural drawings, are to be raised to a height of 1.8m.



Figure 3s: Recommended Treatment for Level 17

Treatments Legend

- Retention of the proposed AWN3 structure, as indicated in the architectural drawings, ensuring its porosity does not exceed 40%.
- Inclusion of 1.5-1.8m high densely foliating evergreen hedges/shrubs within the proposed planter boxes.

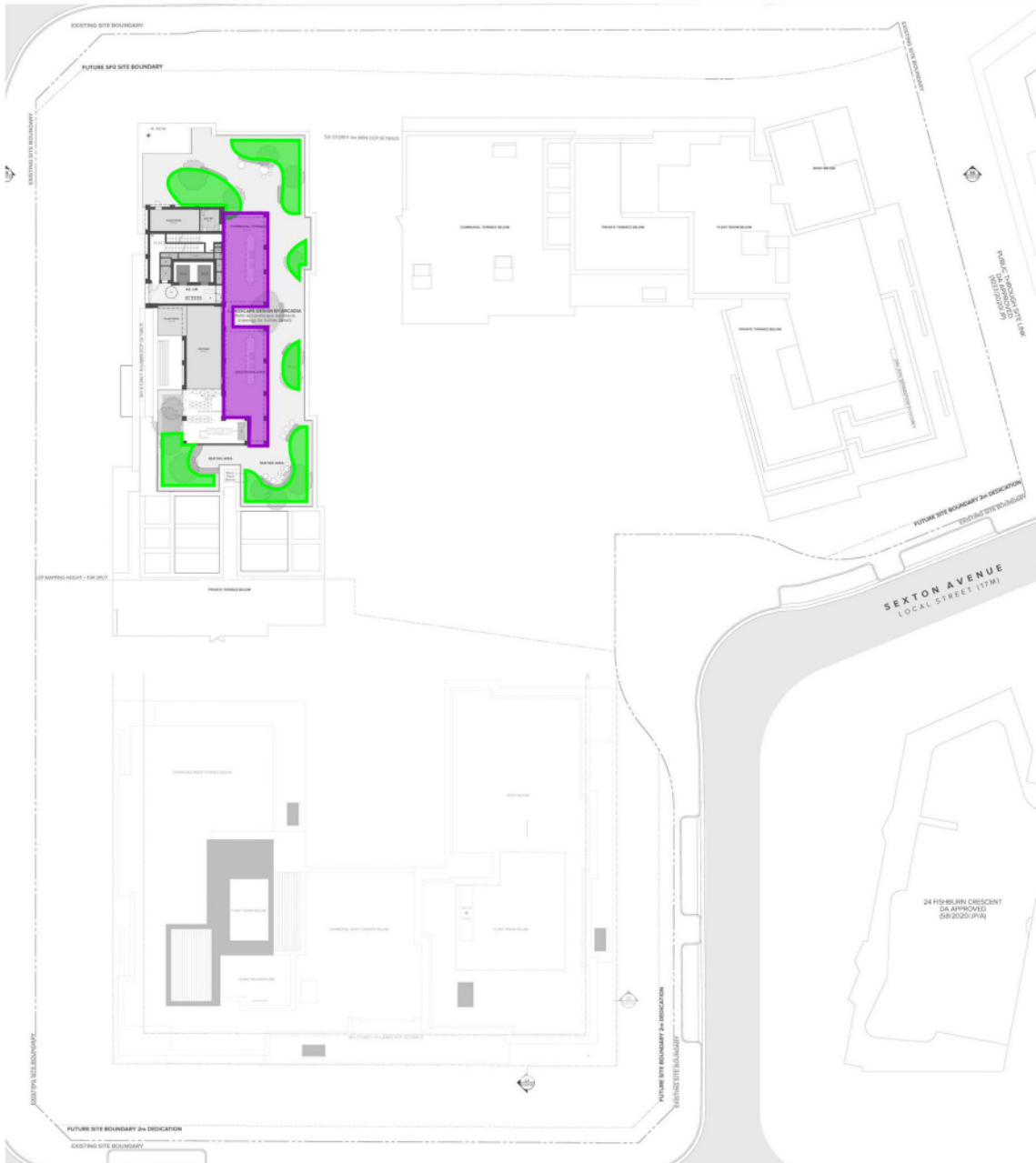

Figure 3t: Recommended Treatment for Level 18 (Building A Roof Level)

REFERENCES

Davenport, A.G., 1972, "An approach to human comfort criteria for environmental conditions". Colloquium on Building Climatology, Stockholm.

Lawson, T.V., 1973, "The wind environment of buildings: a logical approach to the establishment of criteria". Bristol University, Department of Aeronautical Engineering.

Lawson, T.V., 1975, "The determination of the wind environment of a building complex before construction". Bristol University, Department of Aeronautical Engineering.

Lawson, T.V., 1980, "Wind Effects on Buildings - Volume 1, Design Applications". Applied Science Publishers Ltd, Ripple Road, Barking, Essex, England.

Melbourne, W.H., 1978, "Criteria for Environmental Wind Conditions". *Journal of Wind Engineering and Industrial Aerodynamics*, vol. 3, pp241-249.

Penwarden, A.D. (1973). "Acceptable Wind Speeds in Towns", *Building Science*, vol. 8: pp259-267.

Penwarden, A.D., Wise A.F.E., 1975, "Wind Environment Around Buildings". Building Research Establishment Report, London.

APPENDIX A WIND EFFECTS GLOSSARY

A.1 Downwash and Upwash Effects

The downwash wind effect occurs when wind is deflected down the windward face of a building, causing accelerated winds at pedestrian level. This can lead to other adverse effects as corner acceleration as the wind attempts to flow around the building, as seen in Figure A.1.

This can also lead to recirculating flow in the presence of a shorter upstream building, causing local ground level winds to move back into the prevailing wind.

The upwash effect occurs near upper level edge of a building form as the wind flows over the top of the building. This has the potential to cause acceleration of winds near the leading edge, as well as potentially reattaching onto the roof area. This effect causes wind issues particularly near the leading edges of tall building and on the rooftop areas if there is sufficient depth along the wind direction. Upwash is more apparent in taller towers and podia.

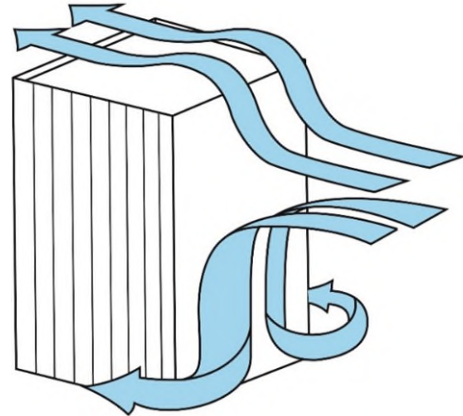

Figure A.1: Downwash Leading to Corner Wind Effect, and Upwash Effects

A.2 Funnelling/Venturi Effect

Funnelling occurs when the wind interacts with two or more buildings which are located adjacent to each other, which results in a bottleneck, as shown in Figure A.2. This causes the wind to be accelerated through the gap between the buildings, resulting in adverse wind conditions and pedestrian discomfort within the constricted space. Funnelling effects are common along pedestrian links and thoroughfares generally located between neighbouring buildings that have moderate gaps between them.

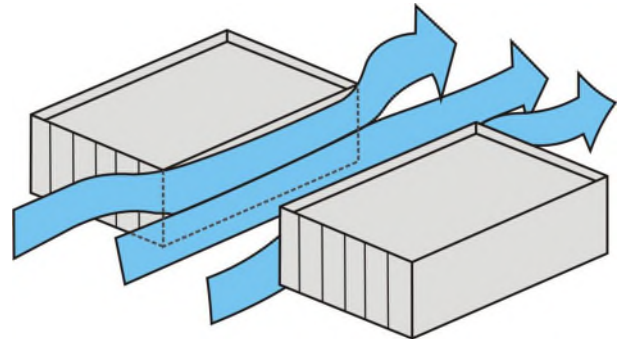

Figure A.2: Funnelling/Venturi Wind Effect

A.3 Gap Effect

The gap effect occurs in small openings in the façade that are open to wind on opposite faces, as seen in Figure 0. This can involve a combination of funnelling and downwash effects. Presenting a small gap in the façade on the windward aspect as the easiest means through which the wind can flow through can result in wind acceleration through this gap. The pressure difference between the windward façade and the leeward façade also tends to exacerbate the wind flow through this gap.

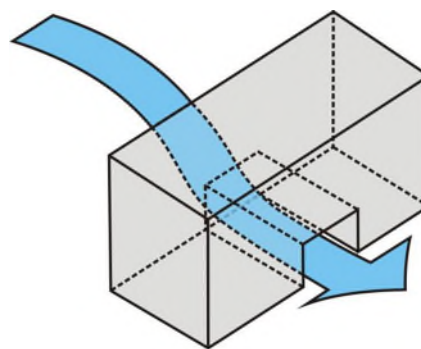

Figure A.3: Gap Wind Effect

A.4 Sidestream and Corner Effects

The sidestream effect is due to a gradual accumulation of wind shearing along the building façade that eventuates in an acceleration corner effect. The flow is parallel to the façade and can be exacerbated by downwash effects as well, or due to corner effect winds reattaching on the façade.

This is shown in Figure A.4. The corner refers to the acceleration of wind at the exterior vertical edge of a building, caused by the interaction of a large building massing with the incident wind, with the flow at the corner being accelerated due to high pressure differentials sets up between the windward façade and the orthogonal aspects. It can be further exacerbated by downwash effects that build up as the flow shears down the façade.

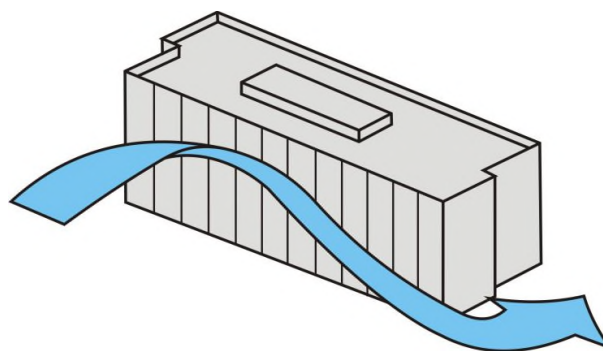

Figure A.4: Sidestream and Corner Wind Effect

A.5 Stagnation

Stagnation in a region refers to an area where the wind velocity is significantly reduced due to the effect of the flow being impeded by the bluff body. For a particular prevailing wind direction, this is typically located near the middle of the windward face of the building form or over a short distance in front of the windward face of a screen or fence. Concave building shapes tend to create an area of stagnation within the cavity, and wind speeds are generally low in these areas.

APPENDIX B LIST OF ARCHITECTURAL DRAWINGS REFERENCED

Table B1: List of Architectural Drawings Referenced (received September 1, 2025)

Drawing Number	Drawing Title	Revision	Date Received
DA-110-007	GA Plans – Lower Ground	ZA	29/08/2025
DA-110-008	GA Plans – Ground Level	Y	29/08/2025
DA-110-009	GA Plans – Upper Ground Level	W	29/08/2025
DA-110-010	GA Plans – Level 01	Q	29/08/2025
DA-110-011	GA Plans – Level 02	P	29/08/2025
DA-110-012	GA Plans – Level 03	P	29/08/2025
DA-110-013	GA Plans – Level 04	P	29/08/2025
DA-110-014	GA Plans – Level 05	P	29/08/2025
DA-110-015	GA Plans – Level 06	P	29/08/2025
DA-110-016	GA Plans – Level 07	S	29/08/2025
DA-110-017	GA Plans – Level 08	P	29/08/2025
DA-110-018	GA Plans – Level 09	P	29/08/2025
DA-110-019	GA Plans – Level 10	S	29/08/2025
DA-110-020	GA Plans – Level 11	Q	29/08/2025
DA-110-021	GA Plans – Level 12	P	29/08/2025
DA-110-022	GA Plans – Level 13	Q	29/08/2025
DA-110-023	GA Plans – Level 14	R	29/08/2025
DA-110-024	GA Plans – Level 15	N	29/08/2025
DA-110-025	GA Plans – Level 16	N	29/08/2025
DA-110-026	GA Plans – Level 17	N	29/08/2025
DA-110-027	GA Plans – Level 18	P	29/08/2025
DA-110-028	GA Plans – Roof Level	N	29/08/2025
DA-210-101	Elevations – North Elevation	B	29/08/2025
DA-210-201	Elevations – East Elevation	B	29/08/2025
DA-210-301	Elevations – South Elevation	B	29/08/2025
DA-210-401	Elevations – West Elevation	B	29/08/2025