

RESIDENTIAL DEVELOPMENT 24, 26 & 28 MIDDLE HARBOUR ROAD, LINDFIELD CIVIL ENGINEERING PLANS



LOCALITY PLAN
SOURCE: NEARMAP - 28.04.2025
NOT TO SCALE

DRAWING INDEX	
DRAWING NO.	DRAWING NAME
C00000	COVER SHEET, LOCALITY PLAN & DRAWING INDEX
C00001	GENERAL NOTES - SHEET 1
C02001	SEDIMENT & EROSION CONTROL PLAN
C02101	SEDIMENT & EROSION CONTROL DETAILS
C03001	CIVIL WORKS PLAN - BASEMENT 03
C03002	CIVIL WORKS PLAN - LOWER GROUND FLOOR
C03003	CIVIL WORKS PLAN - GROUND FLOOR
C05101	WATER SENSITIVE URBAN DESIGN PLAN & DETAILS
C05201	STORMWATER PUMP OUT PIT DETAILS - SHEET 1
C05301	STORMWATER ON-SITE DETENTION TANK DETAILS - SHEET 1
C09001	STORMWATER DRAINAGE DETAILS - SHEET 1

PRINTING NOTE:
THIS DRAWING TO BE PRINTED IN COLOUR.



NOT TO BE USED FOR CONSTRUCTION

DEVELOPMENT APPLICATION

1 ISSUE FOR DEVELOPMENT APPLICATION AH AH 07.05.2025 Rev Description Eng Draft Date	DKO	Deloitte.	X XAVIER KNIGHT T : 02 8810 5800 E : info@xavierknight.com.au A : Level 7, 210 Clarence Street, Sydney NSW 2000 xavierknight.com.au <small>This drawing is copyright and is the property of XAVIER KNIGHT CONSULTING ENGINEERS Pty. Ltd. and must not be used without authorisation.</small>	North 	Project RESIDENTIAL DEVELOPMENT 24, 26 & 28 MIDDLE HARBOUR ROAD, LINDFIELD Sheet Subject COVER SHEET, LOCALITY PLAN & DRAWING INDEX	Scale at A1 N.T.S.	Drawn AH	Approved FC
						Job No 250213	Drawing No C00000	Revision 1

GENERAL

- ALL DIMENSIONS AND ALL LEVELS SHOWN ON THE DRAWINGS ARE IN METERS AND ALL DETAILS ARE IN MILLIMETRES (U.N.O.).
- THESE DRAWINGS SHALL BE READ IN CONJUNCTION WITH ALL ARCHITECTURAL AND OTHER CONSULTANTS' DRAWINGS AND SPECIFICATIONS AND WITH SUCH OTHER WRITTEN INSTRUCTIONS AS MAY BE ISSUED DURING THE COURSE OF THE CONTRACT. ALL DISCREPANCIES SHALL BE REFERRED TO THE ARCHITECT AND ENGINEER BEFORE PROCEEDING WITH THE WORK.
- DIMENSIONS SHALL NOT BE OBTAINED BY SCALING OF THESE DRAWINGS. USE FIGURED DIMENSIONS ONLY.
- SETTING OUT DIMENSIONS AND LEVELS SHOWN ON THE DRAWINGS SHALL BE VERIFIED BY THE CONTRACTOR.
- ALL WORKMANSHIP AND MATERIALS SHALL BE IN ACCORDANCE WITH THE REQUIREMENTS OF THE CURRENT EDITIONS, INCLUDING AMENDMENTS OF THE RELEVANT STANDARDS AND CODES OF PRACTICE EXCEPT AS VARIED BY THE CONTRACT DOCUMENTS AND THE LAWS AND REQUIREMENTS OF THE STATUTORY AUTHORITIES.
- ALL WORKS SHALL BE CARRIED OUT IN ACCORDANCE WITH ALL THE WORKCOVER REQUIREMENTS AND OCCUPATIONAL HEALTH AND SAFETY ACT REGULATIONS
- WHERE THE ENGINEERS ARE ENGAGED FOR INSPECTIONS AND/OR SUPERVISION A MINIMUM OF 24 HOURS NOTICE SHALL BE GIVEN.
- DURING CONSTRUCTION, THE STRUCTURE SHALL BE MAINTAINED IN A STABLE CONDITION AND NO PART SHALL BE OVER-STRESSED. TEMPORARY STRUCTURES, FORMWORK, FALSEWORK, TEMPORARY BRACING, SHORING AND THE LIKE SHALL BE THE SOLE RESPONSIBILITY OF THE CONTRACTOR.
- CONSTRUCTION USING THESE DRAWINGS SHALL NOT COMMENCE UNTIL A CONSTRUCTION CERTIFICATE IS ISSUED BY THE PRINCIPAL CERTIFYING AUTHORITY

GROUND PREPARATION:

- EXCAVATION AND GROUND PREPARATION SHALL BE CARRIED OUT IN ACCORDANCE WITH THE SPECIFICATION FOLLOWING THE RECOMMENDATIONS OF THE GEOTECHNICAL REFERENCES AND ANY ADDITIONAL INSTRUCTIONS THAT MAY BE PROVIDED BY A GEOTECHNICAL ENGINEER DURING THE COURSE OF THE PROJECT.

STORMWATER DRAINAGE

- SELECTION AND INSTALLATION OF PITS, PIPES, TANKS AND TRENCHES SHALL BE IN ACCORDANCE WITH THE CURRENT EDITION OF AS/NZS3500, LOCAL AND STATUTORY REQUIREMENTS (U.N.O.)
- THE CONTRACTOR SHALL IDENTIFY AND LOCATE ALL SERVICES PRIOR TO COMMENCEMENT OF CONSTRUCTION.
- SEDIMENT AND EROSION CONTROLS TO BE PROVIDED IN ACCORDANCE WITH ALL LOCAL AND STATUTORY REGULATIONS.
- WHERE REQUIRED, STORMWATER EASEMENTS SHALL BE OBTAINED BY THE OWNER. ALL NEGOTIATIONS/COMPENSATION PAYMENTS AND THE INTEGRATION OF ANY EASEMENTS INTO THE TITLE DOCUMENTS SHALL BE BY THE OWNER UNLESS AGREED OTHERWISE.
- REFER TO ARCHITECT FOR BUILDING AND DRIVEWAY SETOUT.
- PIPE POSITIONS ARE INDICATIVE ONLY. FINAL POSITIONS TO BE DETERMINED ON-SITE AND SHALL CONFORM WITH THE INTENT OF THE DESIGN.
- THE ENGINEER SHALL BE ADVISED IF ANY EXISTING STRUCTURES ARE WITHIN THE ZONE OF INFLUENCE OF AN EXCAVATION. ANY REQUIRED UNDER-PINNING OR PIERING SHALL BE PROVIDED.
- WHERE EXCAVATING ADJACENT TO BOUNDARIES, ADEQUATE SHORING SHALL BE PROVIDED.
- THE CONTRACTOR SHALL ENSURE THAT ALL NEW STRUCTURES ARE FOUNDED BELOW THE ZONE OF INFLUENCE OF ANY EXCAVATIONS WHETHER THEY BE FOR PIPELINES, TANKS OR OTHER DRAINAGE FACILITIES.
- UNLESS NOTED OTHERWISE, THE MAXIMUM DEVIATION FROM NOMINATED LEVELS SHALL BE ±10mm. EXCEPT IN INSTANCES WHERE SUCH A DEVIATION COULD HAVE ADVERSE EFFECTS, IN WHICH CASE THE ENGINEER SHALL BE CONSULTED.
- LOAD CLASS FOR COVERS/GRATES SHALL BE IN ACCORDANCE WITH AS3996 - 2019. COMMON CASES ARE SUMMARISED IN THE FOLLOWING TABLE:-

CLASS	LOADING	DESCRIPTION
A	10kn	INACCESSIBLE TO VEHICLES, PEDESTRIAN TRAFFIC ONLY
B	80kn	FOR USE ON FOOTWAYS WHERE IT IS POSSIBLE FOR LIGHT VEHICLES OR LIVESTOCK TO USE THE PEDESTRIAN FACILITY
C	150kn	FOR USE IN PEDESTRIAN ACCESS INCLUDING OCCASIONAL MOTOR VEHICLES WITH WHEEL LOADS NOT EXCEEDING 3.7 TONNES OR FOR USE IN MINOR RESIDENTIAL ROADS & CUL-DE-SACS CARRYING SLOW MOVING COMMERCIAL VEHICLES (GENERATING NO IMPACT LOADING) WHERE WHEEL LOADS WILL NOT EXCEED 7.5 TONNES
D	210kn	FOR USE IN CARRIAGEWAYS OF ROADS WHICH CARRY FAST MOVING HEAVY VEHICLES WITH WHEEL LOADS NOT EXCEEDING 5.2 TONNES OR FOR USE IN AREAS TRAFFICKED BY SLOW MOVING HEAVY VEHICLES WITH WHEEL LOADS NOT EXCEEDING 10.5 TONNES

- UNTIL COMPLETION OF ALL WORKS, THE CONTRACTOR SHALL FIRSTLY FILTER ALL STORMWATER IN ACCORDANCE WITH APPROVED DETAILS TO ENSURE THE REMOVAL OF ALL CONCRETE AND PLASTERING FINES, AND OTHER BUILDING SITE POLLUTANTS.
- THE CONTRACTOR SHALL SEEK DIRECTION BEFORE COMMENCING ANY EXCAVATION THAT MAY RESULT IN DAMAGE TO ANY EXISTING TREES.
- UNLESS NOTED OTHERWISE, WHERE A PIT INVERT IS BELOW THE INVERT OF THE LOWEST OUTLET PIPE, THE CONTRACTOR SHALL EITHER PROVIDE DRAINAGE HOLES IN THE BASE OF THE PIT OR ELSE FILL THE BASE OF THE PIT WITH MASS CONCRETE TO THE INVERT OF THE LOWEST OUTLET PIPE.
- WHERE REQUIRED BY REGULATIONS, STEP IRONS IN ACCORDANCE WITH AS1657 SHALL BE INSTALLED IN DEEP PITS/TANKS TO ALLOW ACCESS FOR MAINTENANCE. PIT COVERS OVER DEEP PITS SHALL BE 'CHILD-PROOFED' BY BOLTING THEM DOWN, EXCEPT WHERE THE COVER WEIGHS OVER 30kg.
- ALL IMPERVIOUS SURFACES SHALL BE GRADED SUCH THAT THEY ARE FREE DRAINING.
- YARD PITS SHALL BE PROVIDED AS REQUIRED. YARDS SHALL BE GRADED TO FALL TO PITS UNLESS INDICATED OTHERWISE (eg. BY DESIGN CONTOURS, SPOT LEVELS OR A NOTE).
- WHERE REQUIRED BY THE PRINCIPAL CERTIFIER, WORK-AS-EXECUTED DETAILS SHALL BE PREPARED BY A REGISTERED SURVEYOR/CHARTERED PROFESSIONAL ENGINEER VERIFYING THAT THE DRAINAGE SYSTEM HAS BEEN CONSTRUCTED IN ACCORDANCE WITH THE DRAWINGS. ANY DEVIATIONS FROM THE APPROVED PLANS SHALL BE NOTED AND BROUGHT TO THE ATTENTION OF THE ENGINEER. ADEQUATE INSPECTIONS SHOULD BE CARRIED OUT DURING THE COURSE OF CONSTRUCTION.
- WHERE AN ENGINEER'S CERTIFICATE WILL BE REQUIRED, THE ENGINEER SHALL BE CALLED ON TO INSPECT THE WORKS PRIOR TO ANY CONCRETE POURS, PRIOR TO BACKFILLING AROUND ANY TANKS, AND AT THE COMPLETION OF WORKS. THE ENGINEER SHALL BE GIVEN A MINIMUM OF 24 HOURS NOTICE BEFORE AN INSPECTION IS REQUIRED.

PRINTING NOTE:
THIS DRAWING TO BE PRINTED IN COLOUR.

STORMWATER DRAINAGE CONTINUED

- ANY PROPOSED ALTERATIONS TO THE DETAILS SHOWN ON THE DRAWINGS SHALL BE SUBMITTED TO THE ENGINEER FOR APPROVAL.
- LEAF SCREENS, SILT CONTROLS AND ANY OTHER POLLUTANT CONTROL DEVICES SHALL BE REGULARLY SERVICED TO ENSURE THAT THE DRAINAGE SYSTEM REMAINS UNBLOCKED AND OPERATES AS ORIGINALLY INTENDED.
- OVERLAND FLOW PATHS SHALL BE REGULARLY MAINTAINED AND KEPT FREE OF OBSTRUCTIONS TO THE FLOW OF WATER. SUBSOIL DRAINAGE LINES SHALL BE PROVIDED BEHIND RETAINING WALLS AND OTHER AREAS AS REQUIRED TO RELIEVE HYDROSTATIC PRESSURE AND DRAIN GROUND WATERS. CONNECT INTO THE DRAINAGE SYSTEM IN SUCH A WAY AS TO AVOID BACKFLOW OF STORMWATER INTO THE SUBSOIL DRAINAGE LINE. IF IN DOUBT REFER TO ENGINEER.
- NEW FENCES, RETAINING WALLS AND OTHER LANDSCAPING ITEMS SHALL BE DETAILED IN SUCH A WAY SO AS TO AVOID IMPOUNDING OR DIVERTING SURFACE WATERS ON TO ADJOINING PROPERTIES.
- UPON COMPLETION, PIPE/PIT EXCAVATIONS SHALL BE BACKFILLED WITH SUITABLE COMPACTED MATERIAL IN ACCORDANCE WITH NOTES BELOW.
- ALL PVC PIPES ARE TO BE:-
 - SEWER GRADE (U.N.O.)
 - INSTALLED AND BACKFILLED IN ACCORDANCE WITH AS2566.1
- ALL CONCRETE PIPES ARE TO BE:-
 - STRENGTH LOAD CLASS 4 (U.N.O.)
 - INSTALLED AND BACKFILLED IN ACCORDANCE WITH AS3725 WITH CLASS H2 BEDDING SUPPORT.
- ALL PIPES ARE TO BE INSTALLED WITH 450mm MINIMUM COVER (U.N.O.), WHERE ADEQUATE COVER CANNOT BE PROVIDED PIPES SHALL BE ENCASED IN CONCRETE, REFER TO ENGINEER FOR DETAILS.
- THE CONTRACTOR SHALL ADEQUATELY SHIELD PIPES AGAINST CONSTRUCTION AND PERMANENT LOADS.
- PIPES HAVE BEEN DESIGNED TO WITHSTAND SM1600 TRAFFIC LOADING IN ACCORDANCE WITH AS5100

EXISTING SERVICES

- UTILITY INFORMATION SHOWN ON THE PLANS IS NOT INTENDED TO DEPICT MORE THAN THE PRESENCE OF ANY SERVICES. ACTUAL LOCATIONS SHOULD BE VERIFIED BY HAND EXCAVATION PRIOR TO CONSTRUCTION.
- THE CONTRACTOR SHALL ALLOW FOR THE CAPPING OFF, EXCAVATION AND REMOVAL (IF REQUIRED) OF ALL EXISTING SERVICES IN AREAS AFFECTED BY THE WORKS.
- THE CONTRACTOR SHALL ENSURE THAT SERVICES TO ALL BUILDINGS NOT AFFECTED BY THE WORKS ARE NOT DISRUPTED AT ALL TIMES. THE CONTRACTOR SHALL CONSTRUCT TEMPORARY SERVICES TO MAINTAIN EXISTING SUPPLY TO BUILDINGS REMAINING WHERE REQUIRED. ONCE THE WORKS ARE COMPLETE AND COMMISSIONED THE CONTRACTOR SHALL REMOVE ALL SUCH TEMPORARY SERVICES AND MAKE GOOD ALL DISTURBED AREAS.

EROSION CONTROL

- TEMPORARY PROTECTION FROM WIND AND WATER EROSION WILL BE UNDERTAKEN ON LANDS WHERE WORKS ARE UNLIKELY TO PROCEED FOR PERIODS OF AT LEAST TWO MONTHS AND FINAL SHAPING HAS NOT BEEN COMPLETED (eg. TOPSOIL STOCKPILES), THIS MAY BE ACHIEVED WITH A VEGETATIVE COVER. A RECOMMENDED LISTING OF PLANT SPECIES FOR TEMPORARY COVER IS AS FOLLOWS:-
SEPTEMBER - MARCH SOWING - JAPANESE MILLET @ 50 KG/HA
APRIL - AUGUST SOWING - OATS/RYE/CORN @ 50 KG/HA
- TETILA RYE @ 5 KG/HA
FOOT AND VEHICULAR TRAFFIC SHOULD BE KEPT AWAY FROM ANY REHABILITATED AREAS WHERE PRACTICAL.
- DURING WINDY WEATHER, LARGE, UNPROTECTED AREAS ARE TO BE KEPT MOIST (NOT WET) BY SPRINKLING WITH WATER FOR DUST CONTROL.
- FINAL SITE LANDSCAPING WILL BE UNDERTAKEN ON EACH PRECINCT/AREA AS SOON AS POSSIBLE AND WITHIN 20 WORKING DAYS FROM COMPLETION OF CONSTRUCTION ACTIVITIES.

LAND DISTURBANCE

- THE SOIL EROSION HAZARD ON THE SITE WILL BE KEPT AS LOW AS POSSIBLE AND PRACTICAL. TO THIS END, WORKS IS TO BE UNDERTAKEN IN THE FOLLOWING GENERAL SEQUENCE:-
a) CONSTRUCTION OF SEDIMENT AND EROSION CONTROLS PRIOR TO ANY WORK COMMENCING.
b) REHABILITATION OF ANY DISTURBED LANDS WITHIN 20 WORKING DAYS.
c) UNDERTAKE SITE DEVELOPMENT WORKS IN ACCORDANCE WITH THE ENGINEERING PLANS. WHERE POSSIBLE, PHASE DEVELOPMENT SO THAT LAND DISTURBANCE IS CONFINED TO AREAS OF WORKABLE SIZE.
- THE SITE MANAGER (PRINCIPAL CONTRACTOR) IS TO INFORM ALL CONTRACTORS AND SUBCONTRACTORS OF THEIR OBLIGATIONS UNDER THE EROSION AND SEDIMENT CONTROL PLAN.
- TOPSOIL FROM ALL AREAS THAT WILL BE DISTURBED IS TO BE STRIPPED AND STOCKPILED AT THE NOMINATED LOCATION.
- CUT AND FILL BATTER GRADIENTS TO BE 1 VERTICAL (MAX) : 2 HORIZONTAL (MIN).

INSPECTION AND MAINTENANCE:

- THE SITE MANAGER (PRINCIPAL CONTRACTOR) WILL ENSURE THAT ALL SEDIMENT AND EROSION CONTROL WORKS ARE LOCATED AS INSTRUCTED IN THIS SPECIFICATION OR IN ANY SUBSEQUENT SITE INSTRUCTION
- ALL BUILDERS AND SUB-CONTRACTORS SHALL BE INFORMED OF THEIR RESPONSIBILITIES BY THE SITE MANAGER (PRINCIPAL CONTRACTOR) IN MINIMISING THE POTENTIAL FOR SOIL EROSION AND POLLUTION TO DOWNSLOPE LANDS AND WATERWAYS.
- RECEPTORS FOR CONCRETE AND MORTAR SLURRIES, PAINTS, ACID WASHINGS, LIGHT-WEIGHT WASTE MATERIALS AND LITTER ARE TO BE IDENTIFIED AS NECESSARY. DISPOSAL OF WASTE SHALL BE IN A MANNER APPROVED BY THE SITE SUPERINTENDENT AND GENERALLY OFF SITE.
- AT LEAST WEEKLY, THE CONTRACTOR SHALL INSPECT THE SITE AND ENSURE THAT:-
 - DRAINS OPERATE EFFECTIVELY AND INITIATE REPAIR OR MAINTENANCE AS REQUIRED.
 - SPILLED SOIL (OR OTHER MATERIAL) IS REMOVED FROM HAZARD AREAS, INCLUDING LIKELY AREAS OF CONCENTRATED OR HIGH VELOCITY FLOWS SUCH AS WATERWAYS, GUTTERS, PAVED AREAS AND DRIVEWAYS.
 - SEDIMENT IS REMOVED FROM BASINS AND/OR TRAPS WHEN LESS THAN 20m OF TRAPPING CAPACITY REMAIN PER 100m OF DISTURBED LANDS, AND/OR LESS THAN 500mm DEPTH REMAINS IN THE SETTLING ZONE. ANY COLLECTED SEDIMENT WILL BE DISPOSED IN AREAS WHERE FURTHER POLLUTION TO DOWNSLOPE LANDS AND WATERWAYS IS UNLIKELY.
 - REHABILITATED LANDS HAVE EFFECTIVELY REDUCED THE EROSION HAZARD AND INITIATE UPGRADING OR REPAIRS AS APPROPRIATE.
- THE CONTRACTOR SHALL PROVIDE A DETAILED 'LOG BOOK' RECORDING INFORMATION & DATA WITH RESPECT TO THE SEDIMENT & EROSION CONTROL PLAN AND TO ENSURE SEDIMENT CONTROL DEVICES ARE FUNCTIONING PROPERLY. THIS IS TO BE KEPT ON SITE AT ALL TIMES AND UPDATED DAILY. INFORMATION RECORDED MUST INCLUDE:-
 - RAINFALL EVENTS
 - RAINFALL IN MILLIMETRES
 - RESULTS OF ANY INSPECTIONS

SEDIMENT CONTROL

- THE ARRANGEMENT OF SEDIMENT CONTROL MEASURES SHOWN ON THE PLAN ARE INDICATIVE ONLY AND RELATE TO A PARTICULAR STAGE OF THE CONSTRUCTION WORKS. IT SHALL BE THE CONTRACTOR'S RESPONSIBILITY TO DESIGN, CONSTRUCT AND MAINTAIN ANY ADDITIONAL MEASURES THAT MAY BE REQUIRED FOR THE CONTRACTOR'S CONSTRUCTION METHODOLOGIES, IN ORDER TO MEET ALL CONDITIONS AND REQUIREMENTS IMPOSED BY ANY STATUTORY AUTHORITY.
- ALL SEDIMENT CONTROL MEASURES ARE TO BE INSTALLED PRIOR TO ANY SITE DISTURBANCE.
- STOCKPILES ARE NOT TO BE LOCATED WITHIN 2m OF HAZARD AREAS, INCLUDING LIKELY AREAS OF CONCENTRATED OR HIGH VELOCITY FLOWS SUCH AS WATERWAYS, PAVED AREAS AND DRIVEWAYS. WHERE THEY ARE BETWEEN 2m AND 5m FROM SUCH AREAS, SPECIAL SEDIMENT CONTROL MEASURES SHOULD BE TAKEN TO MINIMISE POSSIBLE POLLUTION OF DOWNSLOPE WATERWAYS (eg. THROUGH INSTALLATION OF SEDIMENT FENCING).
- WATER IS TO BE PREVENTED FROM ENTERING THE PERMANENT DRAINAGE SYSTEM UNLESS THE CATCHMENT AREA HAS BEEN PERMANENTLY LANDSCAPED AND/OR ANY LIKELY SEDIMENT HAS BEEN FILTERED THROUGH AN APPROVED STRUCTURE.
- CONSTRUCT SEDIMENT FENCE AS CLOSE AS POSSIBLE TO PARALLEL TO THE CONTOURS OF THE SITE.
- A STRIP OF TURF 600mm WIDE IS TO BE PLACED IMMEDIATELY BEHIND THE KERB ON ALL NEW ROADS TO ACT AS A FILTER TRAP.
- ALL EXPOSED FILL AREAS ARE TO BE LEFT WITH A LIP AT THE TOP OF THE SLOPE AT THE END OF EACH DAYS OPERATION.
- ALL CUT AND FILL SLOPES ARE TO BE SEEDED AND MULCHED WITHIN 10 DAYS OF COMPLETION OF FORMATION.
- ANY SAND USED IN THE CONCRETE CURING PROCESS (SPREAD OVER THE SURFACE) IS TO BE REMOVED AS SOON AS POSSIBLE AND WITHIN 10 WORKING DAYS AFTER PLACEMENT.
- TEMPORARY SEDIMENT AND EROSION CONTROL STRUCTURES ARE TO BE REMOVED ONLY AFTER THE LANDS THEY ARE PROTECTING ARE REHABILITATED AND WHEN REMOVAL IS APPROVED BY THE SITE SUPERINTENDENT.

UTILITIES

- LOCATE ALL PIPES, DUCTS, CABLES, RETAINING WALLS AND EXCAVATIONS OUTSIDE A 1:2 (VERTICAL:HORIZONTAL) ZONE OF INFLUENCE FROM THE BOTTOM EDGE OF THE FOOTING.
- THE CONTRACTOR MUST TAKE EVERY PRECAUTION TO PROTECT EXISTING GAS, WATER, STORMWATER, SEWERAGE, ELECTRICITY, TELEPHONE CONDUITS AND OTHER EXISTING WORKS AND SERVICES.
- CIVIL WORKS REQUIRED TO PROTECT EXISTING SERVICES IS TO BE AT THE FULL COST OF THE CONTRACTOR.

PAVEMENTS

- WHERE NEW WORKS ARE TO MATCH EXISTING, THE LEVELS GIVEN ARE APPROXIMATE ONLY. ALL NEW WORKS MUST NEATLY JOIN IN WITH EXISTING LEVELS.
- PRIOR TO THE CONSTRUCTION OF NEW ROAD PAVEMENTS, THE SUBGRADE CBR SHALL BE CONFIRMED.
- ADJUST SERVICE COVERS AS NECESSARY TO SUIT PROPOSED LEVELS PROVIDED ON ENGINEERING DRAWINGS.
- ALL JUNCTIONS BETWEEN NEW AND EXISTING PAVEMENT/KERB AND GUTTER WORKS SHALL BE NEATLY SAW CUT.

EARTHWORKS

- ALL TREES AND SHRUBS (UNLESS NOTED TO BE PROTECTED ON THE LANDSCAPE PLANS), RUBBLE, EXISTING PAVEMENT AND EXISTING STRUCTURES WITHIN THE SITE SHALL BE REMOVED AND REUSED OR RECYCLED WHERE POSSIBLE. WHERE NOT POSSIBLE, THIS MATERIAL SHALL BE REMOVED FROM SITE AND DISPOSED OF AS PART OF THE CONTRACT.
- ANY TREES WITHIN THE WORKS AREA WHICH, IN THE OPINION OF THE CONTRACT ADMINISTRATOR, ARE UNSOUND OR WOULD CONSTITUTE A DANGER, SHALL BE CUT DOWN AND REMOVED (EXCEPT THOSE IDENTIFIED AS BEING PROTECTED). ALL STUMPS OF TREES CUT DOWN WITHIN THE BOUNDS OF THE CONSTRUCTION AREA WHICH ARE LARGER THAN 250mm IN GIRTH, SHALL BE COMPLETELY REMOVED.
- ALL ROOTS SHALL BE REMOVED FOR A DEPTH OF 1m. CAVITIES FORMED BY THE REMOVAL OF ROOTS SHALL BE BACKFILLED AND COMPACTED.
- AFTER CLEARING AND GRUBBING ARE COMPLETE, THE CONTRACTOR SHALL STRIP AND STOCKPILE TOPSOIL FROM THE CLEARED AREA (INCLUDING AREAS THAT HAVE BEEN CLEARED AND GRUBBED). REMOVAL OF TOPSOIL FROM ANY SECTION OF THE WORKS SHALL ONLY COMMENCE AFTER SEDIMENT AND EROSION CONTROLS HAVE BEEN IMPLEMENTED.
- TOPSOIL SHALL BE STRIPPED FROM WITHIN THE FORMATION AREAS OF ROADS, PATHWAYS, BUILDING PADS AND MISCELLANEOUS PAVEMENTS, INCLUSIVE OF BATTERS, AND IS TO BE CONSERVED FOR THE TOP-DRESSING OF FORMED FOOTWAYS, BERMS AND BATTERS TO THE SPECIFIED DEPTH, OR WHERE NO DEPTH IS SPECIFIED TO A MINIMUM DEPTH OF 150mm, OR AS DETERMINED ON-SITE.
- EXCAVATED FILL MATERIAL NOT SUITABLE FOR REUSE ON-SITE MUST BE REMOVED OFF-SITE OR OTHERWISE USED IN LANDSCAPING AREAS WHERE AGREED IN ADVANCE WITH ENGINEER.
- EROSION AND SEDIMENT CONTROL MUST BE PROVIDED IN ACCORDANCE WITH THE REQUIREMENTS OF THE LOCAL CITY COUNCIL DCP, DA AND CC CONDITIONS, AND BE INSTALLED TO THE SATISFACTION OF THE ENGINEER.
- THE CONTRACTOR SHALL TAKE ALL NECESSARY STEPS TO LIMIT THE CREATION OF DUST NUISANCE, WHICH MIGHT ARISE DURING THE EXECUTION OF THE WORKS.
- FILL MATERIAL MUST BE PLACED IN MAXIMUM LAYERS OF 200mm (LOOSE) AND COMPACTED TO THE LEVELS AS SPECIFIED ON THE DRAWINGS.
- COMPACTED FILL MUST BE TESTED IN ACCORDANCE WITH THE REQUIREMENTS OF AS3798 AND AS GIVEN IN THE CIVIL SPECIFICATION.
- THE DESIGN CONTOURS AND LEVELS SHOWN ON THE EARTHWORKS DRAWINGS ARE THE FINISHED SURFACE LEVELS UNLESS NOTED OTHERWISE.
- THE CONTRACTOR SHALL PROOF ROLL THE PREPARED SUBGRADE AND EXCAVATED SURFACES IN THE PRESENCE OF THE CONTRACT ADMINISTRATOR. PROOF ROLLING SHALL COMPRISE 6 PASSES OF A MINIMUM 12 TONNE DEADWEIGHT ROLLER. THE FINAL PASS IS TO BE WITNESSED BY A SUITABLY QUALIFIED GEOTECHNICAL ENGINEER. THERE SHALL BE NO VISIBLE DEFLECTION OF THE SURFACE BEING PROOF ROLLED.

KERBING

- ALL KERBS, GUTTERS, DISH DRAINS AND CROSSINGS TO BE CONSTRUCTED ON MINIMUM 75mm GRANULAR BASECOURSE COMPACTED TO MINIMUM 98% MODIFIED MAXIMUM DRY DENSITY IN ACCORDANCE WITH AS1289 5.2.1.
- EXPANSION JOINTS (EJ) TO BE FORMED FROM 10mm COMPRESSIBLE CORK FILLER BOARD FOR FULL DEPTH OF THE SECTION AND CUT TO PROFILE. EXPANSION JOINTS TO BE LOCATED AT DRAINAGE PITS, ON TANGENT POINTS OF CURVES AND ELSEWHERE AT 12m CENTRES EXCEPT FOR INTEGRAL KERBS WHERE THE EXPANSION JOINTS ARE TO MATCH THE JOINT LOCATIONS IN SLABS.
- WEAKENED PLANE JOINTS TO BE MINIMUM 3mm WIDE AND LOCATED AT 3m CENTRES EXCEPT FOR INTEGRAL KERBS WHERE WEAKENED PLANE JOINTS ARE TO MATCH THE JOINT LOCATIONS IN SLABS.
- PROVIDE BROOM FINISH TO ALL RAMPS AND VEHICULAR CROSSINGS. ALL OTHER KERBS OR DISH DRAINS TO BE STEEL FLOAT FINISHED.
- WHERE REPLACEMENT OF EXISTING KERBING IS REQUIRED, ROAD PAVEMENT IS TO BE SAWCUT 900mm FROM LIP OF GUTTER, UPON COMPLETION OF NEW KERBS, NEW BASECOURSE AND SURFACE IS TO BE LAID 900mm WIDE. MAKE GOOD ANY DAMAGE TO SURROUNDING KERBING OR PAVEMENT. EXISTING KERBS ARE TO BE COMPLETELY REMOVED WHERE NEW KERBS ARE SHOWN.

REINFORCEMENT:

- FIX REINFORCEMENT AS SHOWN ON THE DRAWINGS. THE TYPE AND GRADE IS INDICATED BY THE SYMBOL AS SHOWN BELOW ON THE DRAWINGS. THIS IS FOLLOWED BY A NUMERAL WHICH INDICATES A SIZE IN MILLIMETRES OF THE REINFORCEMENT.
N - HOT-ROLLED DEFORMED BAR (GRADE D500N)
R - PLAIN ROUND BAR (GRADE R250N)
SL - SQUARE MESH (GRADE 500L)
RL - RECTANGULAR MESH (GRADE 500L)
- PROVIDE BAR SUPPORTS OR SPACERS TO GIVE CONCRETE COVER TO ALL REINFORCEMENT.
- WELDING OF REINFORCEMENT WILL NOT BE PERMITTED UNLESS SHOWN ON THE STRUCTURAL DRAWINGS.
- SPLICES IN REINFORCEMENT SHALL BE MADE ONLY IN THE POSITIONS SHOWN. THE WRITTEN APPROVAL OF THE ENGINEER SHALL BE OBTAINED FOR ANY OTHER SPLICES WHERE THE LAP LENGTH IS NOT SHOWN.
- CLEAR CONCRETE COVER TO REINFORCEMENT IS AS FOLLOWS UNLESS SHOWN OTHERWISE ON THE DRAWINGS:

ELEMENT	BOTTOM (mm)	SIDES (mm)	TOP (mm)
ALL (U.N.O.)	40	40	40

- COVER TO REINFORCEMENT ENDS TO BE 50mm (U.N.O.).
- PROVIDE N12-450 SUPPORT BARS TO TOP REINFORCEMENT AS REQUIRED, LAP 450 (U.N.O.)
- HOOKS, BENDS, SPLICES AND LAPS TO BE IN ACCORDANCE WITH AS3600.
- AT SPLICES FABRIC SHALL BE LAPPED AS FOLLOWS:

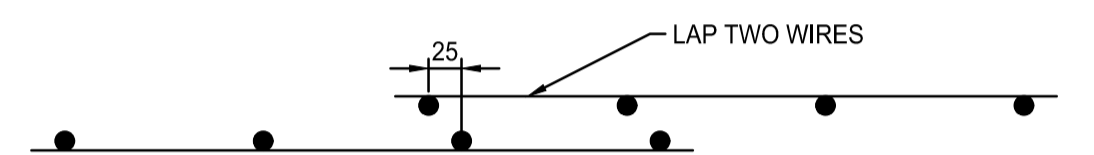

- LAPS IN REINFORCEMENT SHALL BE MADE ONLY WHERE SHOWN ON THE DRAWINGS UNLESS OTHERWISE APPROVED. LAP LENGTHS AS PER THE TABLE BELOW.

TENSION LAPS			COMPRESSION LAPS
BAR SIZE	TOP BARS IN BANDS & BEAMS	ALL OTHER BARS	
N12	570	480	450
N16	800	700	640
N20	1150	950	800
N24	1500	1250	960
N28	1850	1500	1120
N32	2250	1800	1280
N36	2700	2100	1440

CONCRETE:

- ALL WORKMANSHIP AND MATERIALS SHALL BE IN ACCORDANCE WITH AS3600, CURRENT EDITION WITH AMENDMENTS, EXCEPT WHERE VARIED BY THE CONTRACT DOCUMENTS.
- ALL CONCRETE TO BE MANUFACTURED AND SUPPLIED ACCORDING TO AS1379.
- USE TYPE 'GP' CEMENT UNLESS OTHERWISE SPECIFIED.
- CONCRETE QUALITY SHALL CONFORM TO THE FOLLOWING (U.N.O.):

ELEMENT	SLUMP (mm)	MAX. SIZE AGGREGATE (mm)	STRENGTH (MPa)	SHRINKAGE STRAIN μ (MAX.)
EXTERNAL	80	20	S32MPa	650
FOOTPATH	80	20	S32MPa	650
BLOCKWORK COREFILLING	-	-	S32MPa	-

- ALL CONCRETE SHALL BE SUBJECT TO PROJECT ASSESSMENT AND TESTING TO AS1379.
- CONSOLIDATE ALL CONCRETE BY MECHANICAL VIBRATION. CURE ALL CONCRETE SURFACES AS DIRECTED IN THE SPECIFICATION. (IF NO SPECIFICATION, IN ACCORDANCE WITH AS3600).
- FOR ALL FALLS IN SLAB, DRIP GROOVES, REGLETS, CHAMFERS ETC REFER TO ARCHITECTS DRAWINGS AND SPECIFICATION.
- NO HOLES OR CHASES OTHER THAN THOSE SHOWN ON THE STRUCTURAL DRAWINGS SHALL BE MADE IN CONCRETE MEMBERS WITHOUT THE PRIOR APPROVAL OF THE ENGINEER.
- CONSTRUCTION JOINTS WHERE NOT SHOWN ON DRAWINGS SHALL BE LOCATED SUBJECT TO THE APPROVAL OF THE ENGINEER.
- CONCRETE THICKNESSES SHOWN DO NOT INCLUDE THICKNESS OF APPLIED FINISHES.
- BEAM DEPTHS ARE NOTED FIRST AND INCLUDE SLAB THICKNESSES, IF ANY.
- FORMWORK: THE DESIGN, CERTIFICATION, CONSTRUCTION AND PERFORMANCE OF THE FORMWORK, FALSEWORK AND BACKPROPPING SHALL BE THE RESPONSIBILITY OF THE CONTRACTOR. THE PROPOSED METHOD OF INSTALLATION AND REMOVAL OF FORMWORK IS TO BE SUBMITTED TO THE SUPERINTENDENT FOR COMMENT PRIOR TO WORK BEING CARRIED OUT.













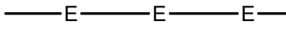
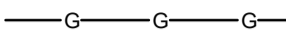
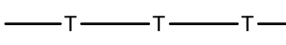
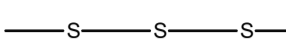
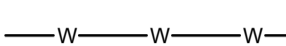

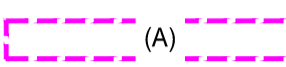

NOT TO BE USED FOR CONSTRUCTION

DEVELOPMENT APPLICATION

Architect		Client		North		Project		Scale at A1		Drawn		Approved			
						T : 02 8810 5800 E : info@xavierknight.com.au A : Level 7, 210 Clarence Street, Sydney NSW 2000 xavierknight.com.au This drawing is copyright and is the property of XAVIER KNIGHT CONSULTING ENGINEERS Pty. Ltd. and must not be used without authorisation.		RESIDENTIAL DEVELOPMENT		N.T.S.		AH		FC	
								24, 26 & 28 MIDDLE HARBOUR ROAD, LINDFIELD							
1 ISSUE FOR DEVELOPMENT APPLICATION AH AH 07.05.2025								Job No		Drawing No		Revision			
Rev Description Eng Draft Date								250213		C00001		1			

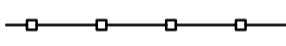
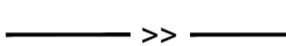
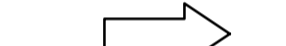
LEGEND

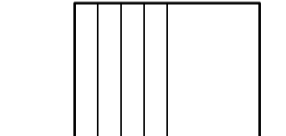
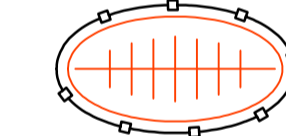
-  SITE BOUNDARY
-  LIMIT OF WORKS
-  SURVEY. REFER TO DRAWINGS BY CMS SURVEYORS PTY LTD, ISSUE 1, DATED 13/08/2024
-  EXISTING ELECTRICAL LINE
-  EXISTING GAS LINE
-  EXISTING TELECOMMUNICATION LINE
-  EXISTING SEWER LINE
-  EXISTING WATER LINE
-  EXISTING OVERHEAD POWER LINE
-  (A) EXISTING EASEMENT TO BE REMOVED REFER TO SURVEY FOR DETAILS
-  EXISTING STORMWATER PIPE FROM BYDA CONTRACTOR TO CONFIRM LEVELS & LOCATION ON SITE PRIOR TO COMMENCEMENT OF WORKS
-  EXISTING STORMWATER PITS FROM BYDA CONTRACTOR TO CONFIRM LEVELS & LOCATION ON SITE PRIOR TO COMMENCEMENT OF WORKS
-  EXISTING STORMWATER PITS FROM BYDA CONTRACTOR TO CONFIRM LEVELS & LOCATION ON SITE PRIOR TO COMMENCEMENT OF WORKS
-  EXISTING STORMWATER PIPES TO BE DEMOLISHED
-  EXISTING STRUCTURES TO BE DEMOLISHED
-  EXISTING TREES TO REMAIN REFER TO ARBORIST REPORT
-  EXISTING TREES TO BE REMOVED REFER TO ARBORIST REPORT
-  SEDIMENT FENCE
-  TEMPORARY CATCH DRAIN DURING CONSTRUCTION
-  FLOW DIRECTION
-  SAND BAG
-  PROPOSED STABILISED SITE ACCESS WITH SHAKER RAMP
-  PROPOSED STOCKPILE LOCATION WITH SEDIMENT FENCE

- NOTES:**
1. ALL EXISTING UTILITY & SERVICES INFORMATION TO BE VERIFIED BY CONTRACTOR PRIOR TO COMMENCEMENT OF WORKS
 2. ALL EXISTING STORMWATER PITS & PIPES' LOCATION TO BE CONFIRMED BY DETAILED SURVEY PRIOR TO DETAILED DESIGN STAGE
 3. ALL WORKS OUTSIDE SITE BOUNDARY SUBJECT TO S138 APPROVAL FROM COUNCIL
 4. ALL SEDIMENT & EROSION CONTROL MEASURES TO BE ADJUSTED BY CONTRACTOR ON SITE AS REQUIRED BASED ON SITE CONDITIONS
 5. REFER TO DRAWING C02101 FOR TYPICAL DETAILS OF ALL PROPOSED SEDIMENT & EROSION CONTROL MEASURES



SEDIMENT BASIN CALCULATION			
SOIL TYPE	D OR F	(ASSUMED)	
RAINFALL DEPTH =	60.7	mm	(2-YEAR ARI, 6 HOUR EVENT)
C _v =	0.79		(TABLE F2)
A =	0.476	Ha	
R _{50day} =	23.4	mm	(TABLE 6.3A)
SETTLING ZONE = 10 x C _v x A x R =	88	m ³	
SEDIMENT STORAGE ZONE = 50% OF SETTLING ZONE CAPACITY	44	m ³	
TOTAL SEDIMENT BASIN VOLUME =	132	m ³	

SURVEYOR NOTE:
POTHOLING OR SCANNING SURVEY NEEDED.

SERVICES LINES NOTE:
ALL SERVICES LINES ARE INDICATIVE AND TO BE CONFIRMED BY OTHERS PRIOR TO CONSTRUCTIONS

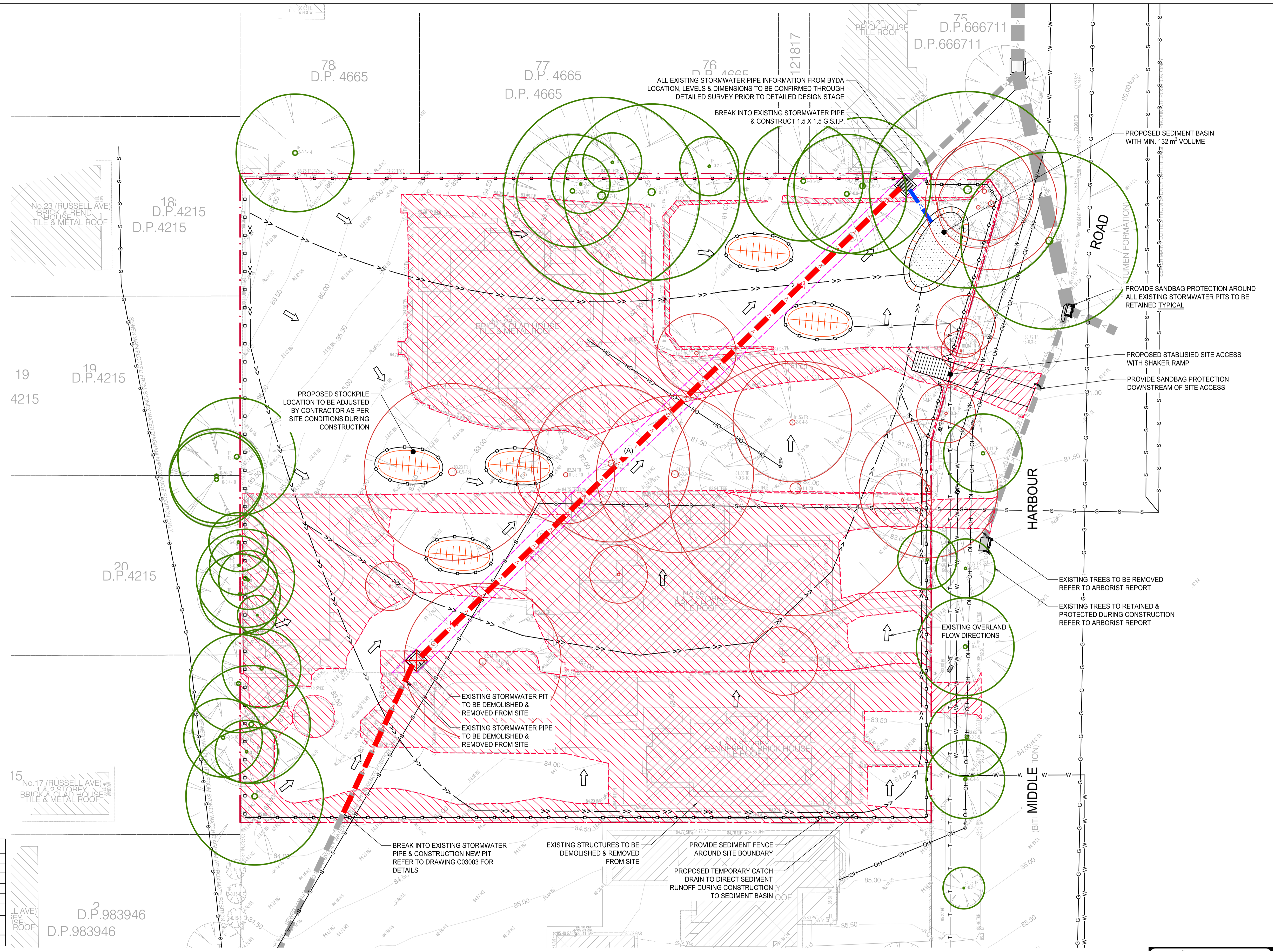
PRINTING NOTE:
THIS DRAWING TO BE PRINTED IN COLOUR.



A1 1:200			
Architect	Client	North	
			
1 ISSUE FOR DEVELOPMENT APPLICATION AH AH 07.05.2025		Project RESIDENTIAL DEVELOPMENT 24, 26 & 28 MIDDLE HARBOUR ROAD, LINDFIELD	
Rev Description	Eng Draft Date	Sheet Subject SEDIMENT & EROSION CONTROL PLAN	



T : 02 8810 5800 E : info@xavierknight.com.au
A : Level 7, 210 Clarence Street, Sydney NSW 2000
xavierknight.com.au
This drawing is copyright and is the property of XAVIER KNIGHT CONSULTING ENGINEERS Pty. Ltd. and must not be used without authorisation.

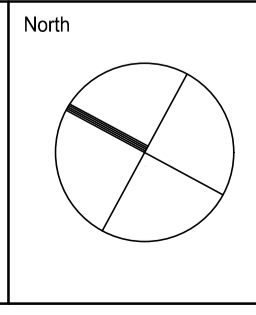

Project	Scale at A1	Drawn	Approved
RESIDENTIAL DEVELOPMENT 24, 26 & 28 MIDDLE HARBOUR ROAD, LINDFIELD	1:200	AH	FC
Sheet Subject	Job No	Drawing No	Revision
SEDIMENT & EROSION CONTROL PLAN	250213	C02001	1

NOT TO BE USED FOR CONSTRUCTION

DEVELOPMENT APPLICATION



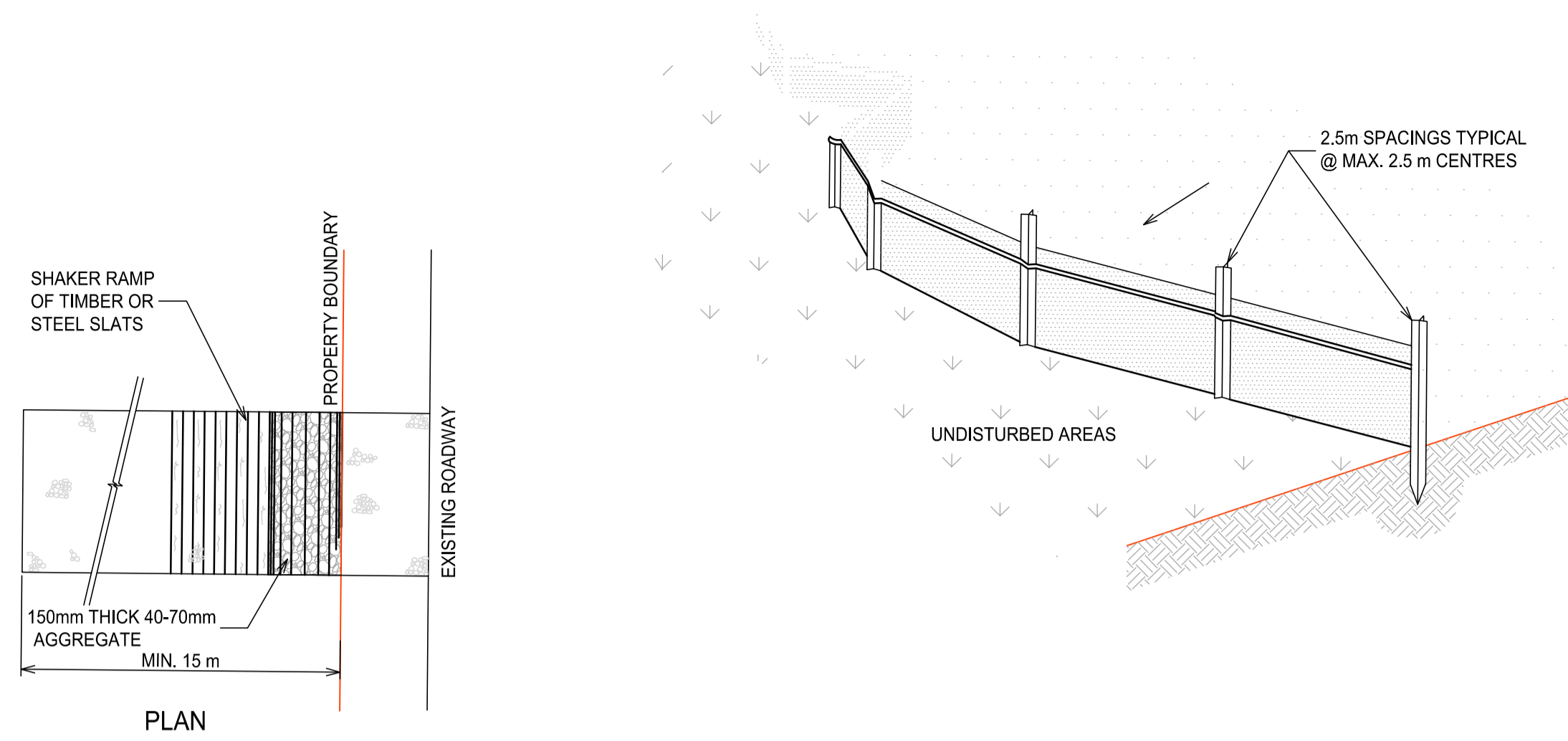

STABILISED SITE ACCESS WITH SHAKER RAMP
SCALE N.T.S.

SEDIMENT FENCE
SCALE N.T.S.

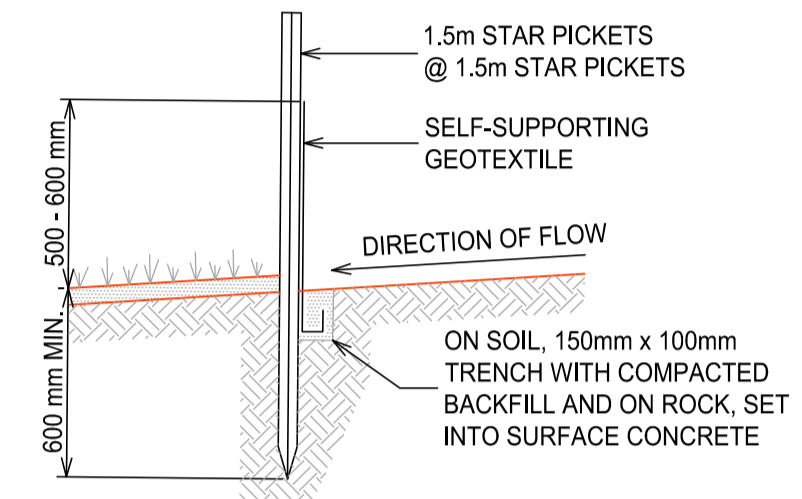
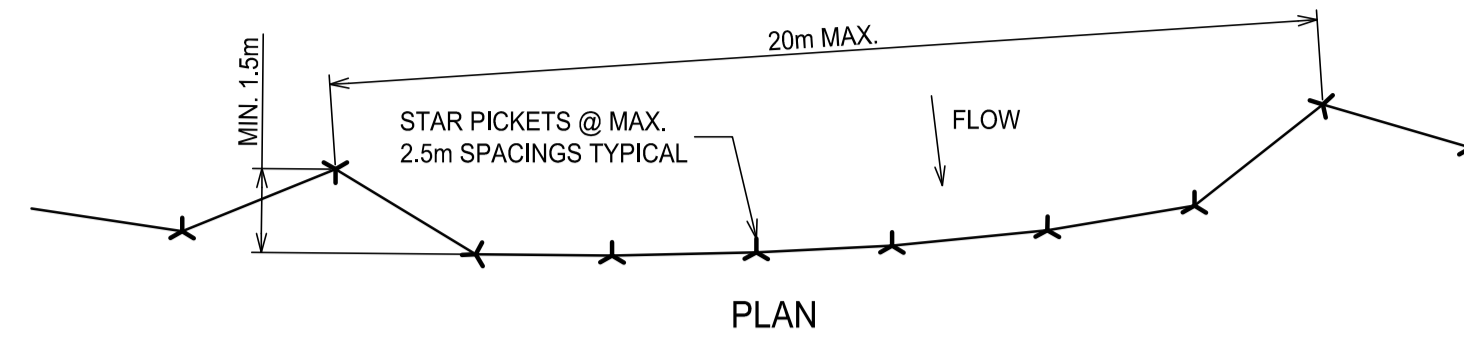

SECTION DETAIL

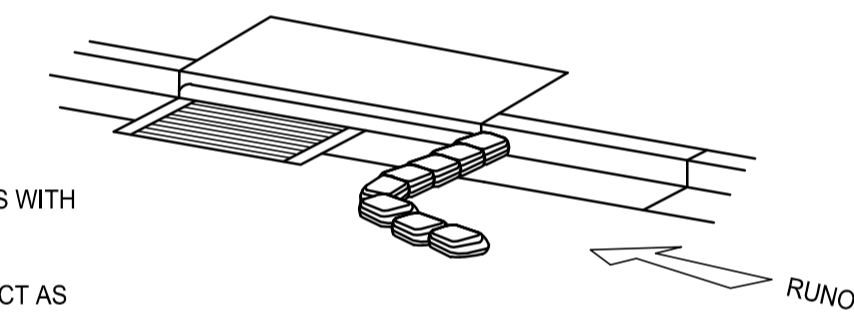

- NOTES:**
1. PROVIDE THREE LAYERS OF SANDBAGS WITH THEIR ENDS OVERLAPPED AND ALSO OVERLAPPING ONTO THE KERB.
 2. CREATE A GAP IN THE SANDBAGS TO ACT AS A SPILLWAY.
 3. SANDBAG BARRIER TO BE MIN. 2m FROM THE INLET AND EXTEND MIN. 0.9m OUT FROM THE KERB.

GULLY INLET SANDBAG PROTECTION DETAIL
SCALE N.T.S.

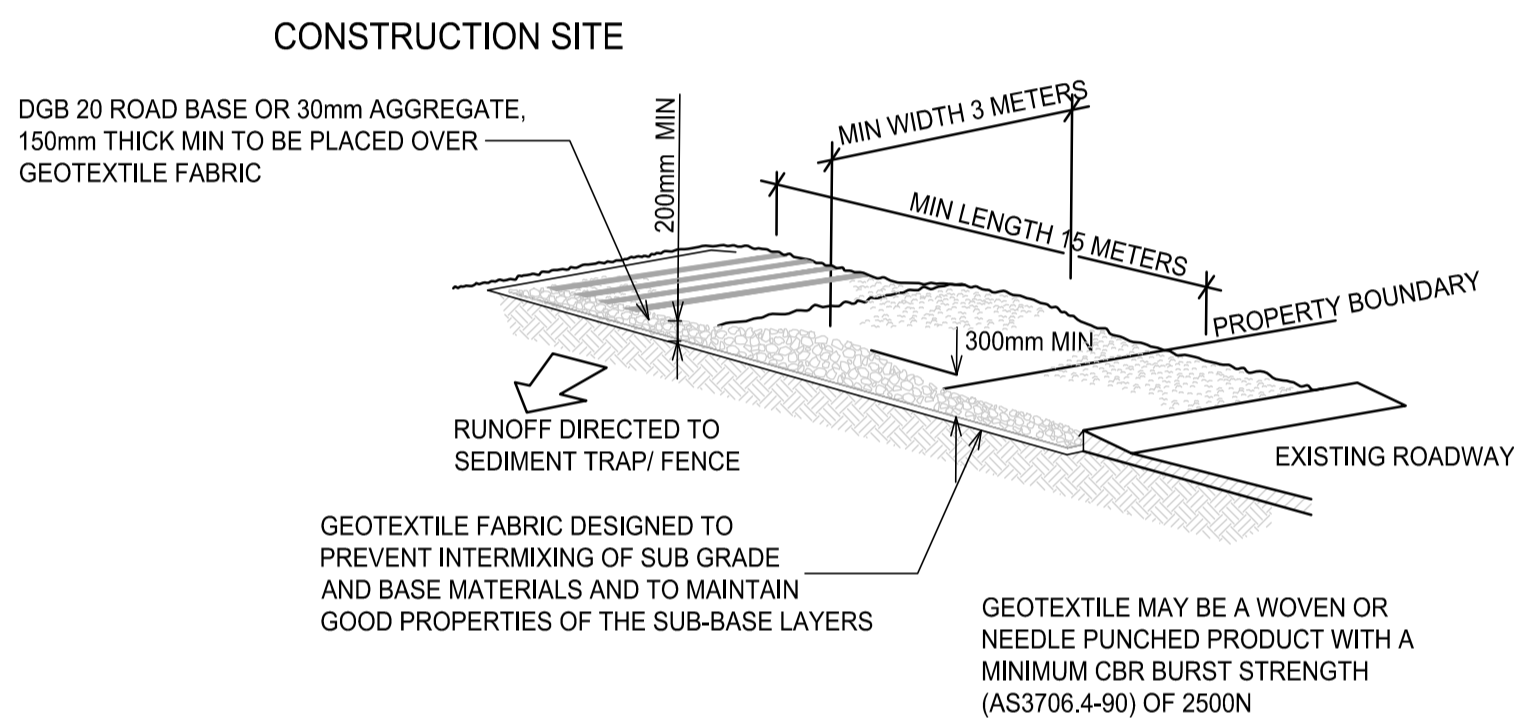

STABILISED SITE ACCESS WITH SHAKER RAMP
SCALE N.T.S.

- NOTES:**
1. THIS DEVICE IS TO BE LOCATED AT ALL EXITS FROM CONSTRUCTION SITE.
 2. THIS DEVICE IS TO BE REGULARLY CLEANED OF DEPOSITED MATERIAL SO AS TO MAINTAIN A 50mm DEEP SPACE BETWEEN PLANKS.
 3. ANY UNSEALED ROAD BETWEEN THIS DEVICE AND NEAREST ROADWAY IS TO BE TOPPED WITH 100mm THICK 40-70mm SIZE AGGREGATE.
 4. ALTERNATIVELY, THREE(3) PRECAST CONCRETE CATTLE GRIDS (AS MANUFACTURED BY "HUMES CONCRETE" MAY BE USED. 1, 2 & 3 ABOVE ALSO APPLY.

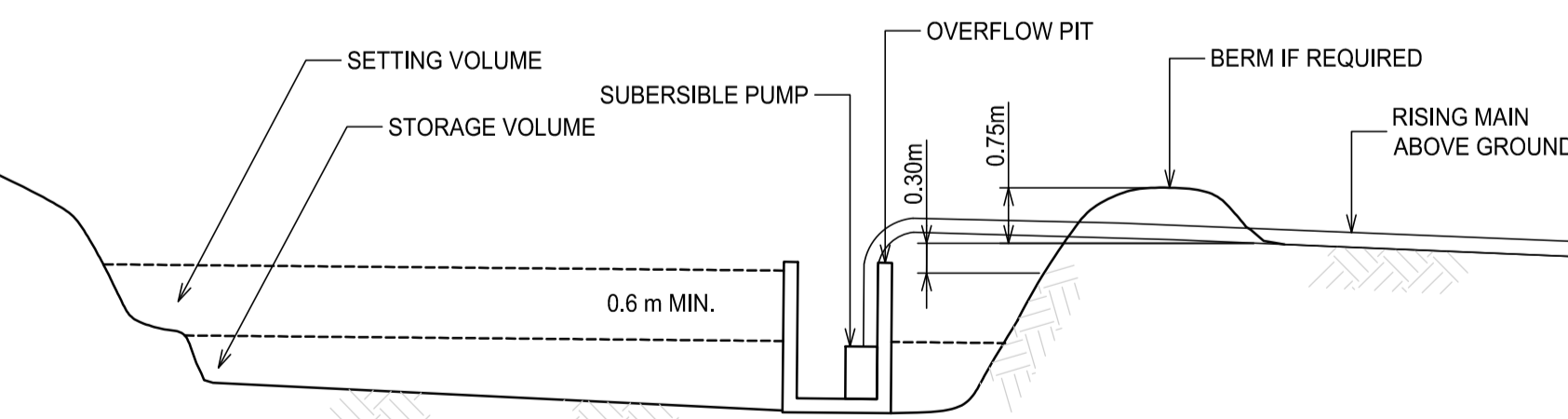

TYPICAL SEDIMENT BASIN
SCALE N.T.S.

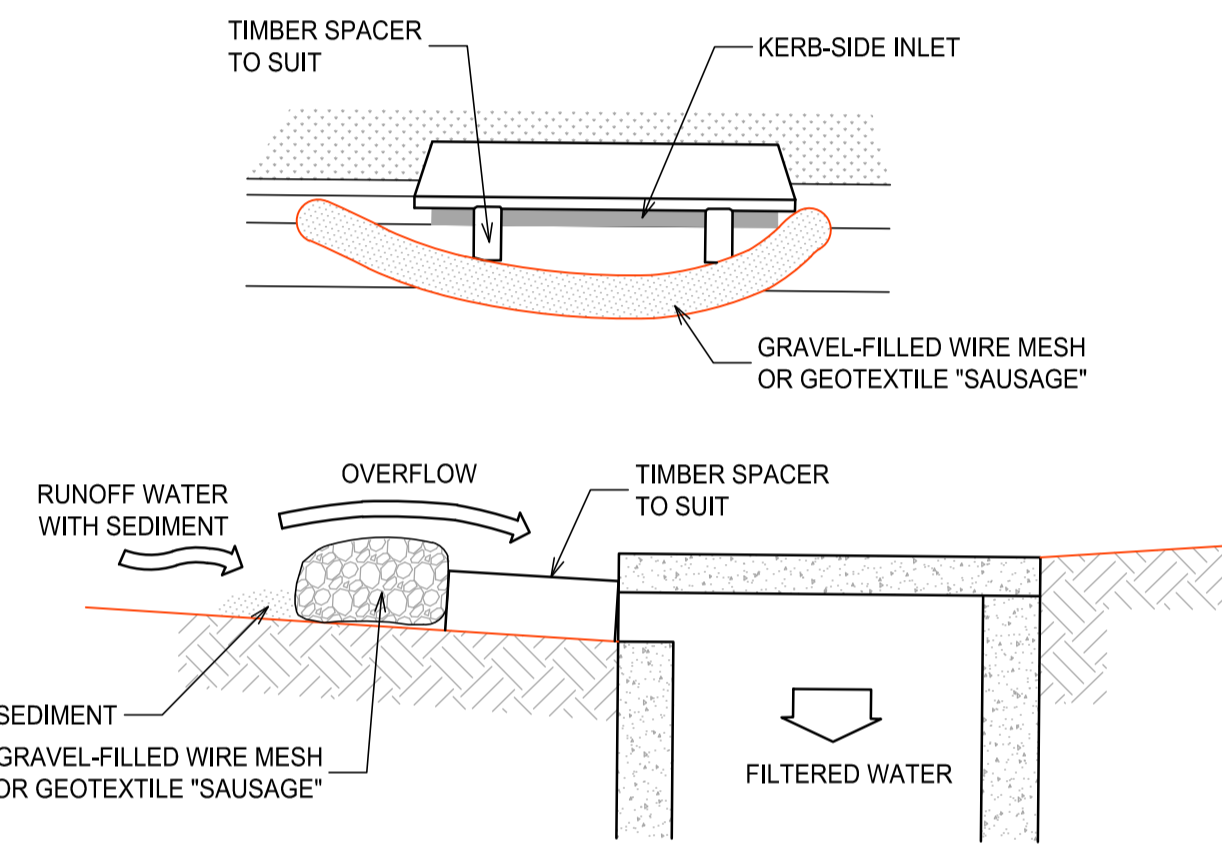

- MESH & GRAVEL INLET FILTER CONSTRUCTION NOTES:**
1. FABRICATE A SLEEVE MADE FROM GEOTEXTILE OR WIRE MESH LONGER THAN THE LENGTH OF THE INLET PIT AND FILL IT WITH 25mm TO 50mm GRAVEL.
 2. FORM AN ELLIPTICAL CROSS-SECTION ABOUT 150mm HIGH x 400mm WIDE.
 3. PLACE THE FILTER AT THE OPENING LEAVING AT LEAST A 100mm SPACE BETWEEN IT AND THE KERB INLET. MAINTAIN THE OPENING WITH SPACER BLOCKS.
 4. FORM A SEAL WITH THE KERB TO PREVENT SEDIMENT BYPASSING THE FILTER.
 5. SANDBAGS FILLED WITH GRAVEL CAN SUBSTITUTE FOR THE MESH OR GEOTEXTILE PROVIDING THEY ARE PLACED SO THAT THEY CAN FIRMLY ABUT EACH OTHER AND SEDIMENT / LADEN WATERS CANNOT PASS BETWEEN.

MESH & GRAVEL INLET FILTER
SCALE N.T.S.

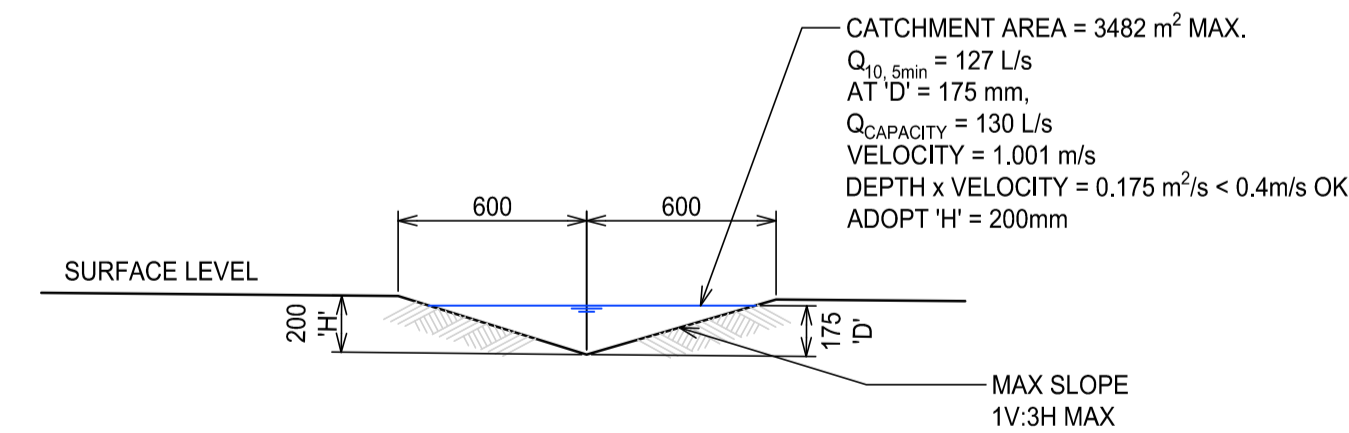

TYPICAL SECTION THROUGH CATCH DRAIN

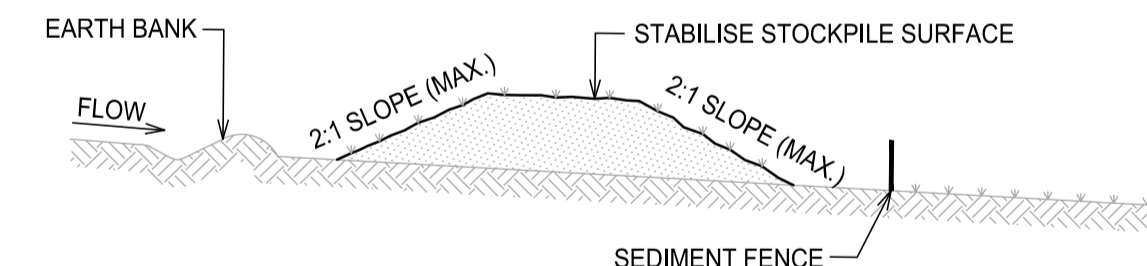

- STOCKPILE CONSTRUCTION NOTES:**
1. PLACE STOCKPILES MORE THAN 2 (PREFERABLY 5) METRES FROM EXISTING VEGETATION, CONCENTRATED WATER FLOW, ROADS AND HAZARD AREAS.
 2. CONSTRUCT ON THE CONTOUR AS LOW, FLAT, ELONGATED MOUNDS.
 3. WHERE THERE IS SUFFICIENT AREA, TOPSOIL STOCKPILES SHALL BE LESS THAN 2 METRES IN HEIGHT.
 4. WHERE THEY ARE TO BE PLACED FOR MORE THAN 10 DAYS, STABILISE FOLLOWING THE APPROVED E.S.C.P. OR S.W.M.P. TO REDUCE THE C-FACTOR TO LESS THAN 0.10.
 5. CONSTRUCT EARTH BANKS ON THE UPSLOPE SIDE TO DIVERT WATER AROUND STOCKPILES AND SEDIMENT FENCES 1 TO 2 METRES DOWNSLOPE.

STOCKPILES
SCALE N.T.S.

SEDIMENT FENCE CONSTRUCTION NOTES:

1. CONSTRUCT SEDIMENT FENCES AS CLOSE AS POSSIBLE TO BEING PARALLEL TO THE CONTOURS OF THE SITE, BUT WITH SMALL RETURNS AS SHOWN IN THE DRAWING TO LIMIT THE CATCHMENT AREA OF ANY ONE SECTION. THE CATCHMENT AREA SHOULD BE SMALL ENOUGH TO LIMIT WATER FLOW IF CONCENTRATED AT ONE POINT TO 50 LITRES PER SECOND IN THE DESIGN STORM EVENT, USUALLY THE 10-YEAR EVENT.
2. CUT A 150 mm DEEP TRENCH ALONG THE UPSLOPE LINE OF THE FENCE FOR THE BOTTOM OF THE FABRIC TO BE ENTRENCHED.
3. DRIVE 1.5 m LONG STAR PICKETS INTO GROUND @ 2.5 m INTERVALS (MAX.) AT THE DOWNSLOPE EDGE OF THE TRENCH. ENSURE ANY STAR PICKETS ARE FITTED WITH SAFETY CAPS.
4. FIX SELF-SUPPORTING GEOTEXTILE TO THE UPSLOPE SIDE OF THE POSTS ENSURING IT GOES TO THE BASE OF THE TRENCH. FIX THE GEOTEXTILE WITH WIRE TIES OR AS RECOMMENDED BY THE MANUFACTURER. ONLY USE GEOTEXTILE SPECIFICALLY PRODUCED FOR SEDIMENT FENCING. THE USE OF SHADE CLOTH FOR THIS PURPOSE IS NOT SATISFACTORY.
5. JOIN SECTIONS OF FABRIC AT A SUPPORT POST WITH A 150 mm OVERLAP.
6. BACKFILL THE TRENCH OVER THE BASE OF THE FABRIC AND COMPACT IT THOROUGHLY OVER THE GEOTEXTILE.

GENERAL INSTRUCTIONS:

1. THIS SOIL AND WATER MANAGEMENT WORKS FOR THE SITE SHALL BE CARRIED OUT IN ACCORDANCE WITH THE REQUIREMENTS OF "MANAGING URBAN STORMWATER - SOILS AND CONSTRUCTION, 4TH EDITION (2004)" BY LANDCOM.
2. AS REQUIRED BY COUNCIL, SEDIMENT CONTROL MEASURES WILL BE REQUIRED DURING THE CONSTRUCTION OF ALL DEVELOPMENTS/BUILDING WORKS. IT SHALL BE THE CONTRACTOR'S RESPONSIBILITY THAT THE WORKS ARE CARRIED OUT IN ACCORDANCE WITH THE SOIL AND WATER MANAGEMENT PLAN AND COUNCIL'S REQUIREMENTS.
3. THE CONTRACTOR SHALL ENSURE THAT ALL SUBCONTRACTORS ARE INFORMED OF THEIR RESPONSIBILITIES IN MINIMISING THE POTENTIAL FOR SOIL EROSION AND POLLUTION TO DOWNSLOPE AREAS.
4. THE NON-DISTURBED PORTION OF THE CATCHMENT OUTSIDE OF OPERATING AREA IS TO BYPASS THE BASINS BY MEANS OF LINED CATCH DRAINS.
5. WHERE PRACTICABLE, THE SOIL EROSION HAZARD SHALL BE KEPT AS LOW AS POSSIBLE. LIMITATIONS TO ACCESS ARE TO BE VIA STANLEY LANE UNLESS OTHERWISE APPROVED BY COUNCIL.
6. ENSURE THAT ALL DRAINS ARE OPERATING EFFECTIVELY AND SHALL MAKE ANY NECESSARY REPAIRS. REMOVE TRAPPED SEDIMENT WHERE THE CAPACITY OF THE TRAPPING DEVICE FALLS BELOW 60%.
7. CONSTRUCT ADDITIONAL EROSION OR SEDIMENT CONTROL WORKS AS MAY BE APPROPRIATE TO ENSURE THE PROTECTION OF DOWNSLOPE LANDS AND WATERWAYS.
8. MAINTAIN EROSION AND SEDIMENT CONTROL MEASURES IN A FULLY FUNCTIONING CONDITION AT ALL TIMES UNTIL THE SITE IS REHABILITATED.
9. REMOVE TEMPORARY SOIL CONSERVATION STRUCTURES AS THE LAST ACTIVITY IN THE REHABILITATION PROGRAM.

CONSTRUCTION SEQUENCE:

- WORKS SHALL BE UNDERTAKEN IN THE FOLLOWING SEQUENCE:
1. INSTALL SEDIMENT FENCING AND CUT DRAINS TO MEET THE REQUIREMENTS OF THE SOIL AND WATER MANAGEMENT PLAN. WASTE COLLECTION BINS SHALL BE INSTALLED ADJACENT TO SITE OFFICE.
 2. CONSTRUCT STABILISED SITE ACCESS IN ACCORDANCE WITH COUNCIL'S REQUIREMENTS.
 3. REDIRECT CLEAN WATER AROUND THE CONSTRUCTION SITE.
 4. INSTALL SEDIMENT CONTROL PROTECTION MEASURES AT ALL NATURAL AND MAN-MADE DRAINAGE STRUCTURES. MAINTAIN UNTIL ALL THE DISTURBED AREAS ARE STABILISED.
 5. CLEAR AND STRIP THE WORK AREAS. MINIMISE THE DAMAGE TO THE GRASS AND LOW GROUND COVER OF NON-DISTURBED AREAS.
 6. ANY DISTURBED AREAS, OTHER THAN BUILDING PAD AREAS, SHALL IMMEDIATELY BE COVERED WITH SITE TOPSOIL WITHIN 7 DAYS OF CLEARING. BUILDING PAD AREAS SHALL BE COVERED WITH BITUMEN EMULSION AS SPECIFIED.
 7. APPLY PERMANENT STABILISATION TO SITE (LANDSCAPING).

PRINTING NOTE:
THIS DRAWING TO BE PRINTED IN COLOUR.













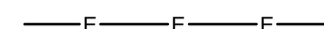
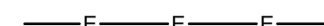
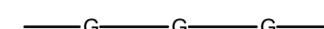

NOT TO BE USED FOR CONSTRUCTION

DEVELOPMENT APPLICATION

Architect	Client	North	Project	Scale at A1	Drawn	Approved
DKO	Deloitte		RESIDENTIAL DEVELOPMENT 24, 26 & 28 MIDDLE HARBOUR ROAD, LINDFIELD	N.T.S.	AH	FC
1 ISSUE FOR DEVELOPMENT APPLICATION			Sheet Subject	Job No	Drawing No	Revision
Rev Description			SEDIMENT & EROSION CONTROL DETAILS	250213	C02101	1

T : 02 8810 5800 E : info@xavierknight.com.au
A : Level 7, 210 Clarence Street, Sydney NSW 2000
xavierknight.com.au
This drawing is copyright and is the property of XAVIER KNIGHT CONSULTING ENGINEERS Pty. Ltd. and must not be used without authorisation.

LEGEND

-  SITE BOUNDARY
LIMIT OF WORKS
-  SURVEY. REFER TO DRAWINGS BY
CMS SURVEYORS PTY LTD, ISSUE 1,
DATED 13/08/2024
-  ARCHITECTURAL LAYOUT BY DKO
-  EXISTING ELECTRICAL LINE
-  EXISTING ELECTRICAL LINE
-  EXISTING GAS LINE
-  EXISTING TELECOMMUNICATION LINE
-  EXISTING SEWER LINE
-  EXISTING WATER LINE
-  EXISTING OVERHEAD POWER LINE
-  EXISTING STORMWATER PIPE FROM BYDA
CONTRACTOR TO CONFIRM LEVELS &
LOCATION ON SITE PRIOR TO COMMENCEMENT
OF WORKS
-  PROPOSED Ø150mm uPVC STORMWATER
PIPE @ MIN. 1% GRADE U.N.O.
-  STORMWATER RISING MAIN PIPE
-  600 X 600 HEEL SAFE GRATED SURFACE INLET PIT (G.S.I.P.)
U.N.O.
-  DOWN PIPE OUTLET
-  VERTICAL DROPPER

NOTES:

1. ALL EXISTING UTILITY & SERVICES INFORMATION TO BE VERIFIED BY CONTRACTOR PRIOR TO COMMENCEMENT OF WORKS
2. ALL EXISTING STORMWATER PITS & PIPES' LOCATION TO BE CONFIRMED BY DETAILED SURVEY PRIOR TO DETAILED DESIGN STAGE
3. ALL STORMWATER PIPES TO BE STRAPPED TO UNDERSIDE OF SLABS U.N.O.
4. ALL STORMWATER PIPES TO BE MIN. Ø150mm uPVC AT MIN. 1% GRADE TO PITS U.N.O.
5. ALL STORMWATER GRATED ACCESS LIDS TO BE HEEL SAFE
6. ALL STORMWATER PIT LIDS TO MEET REQUIREMENTS OF AS3996 AS SPECIFIED IN DRAWING C00001
7. ALL SLABS TO BE AT MIN. 1% GRADE TO INLET PITS
8. REFER TO DRAWING C05201 FOR PUMP OUT TANK DETAILS

PIPE NOTE:

ALL PIPES ARE Ø150mm uPVC @ MIN. 1% GRADE & STRAPPED UNDERNEATH THE BASEMENT SLAB

SLAB NOTE:

SLAB TO BE GRADED AT MIN. 1% GRADE TOWARDS PITS TO MEET REQUIREMENTS OF AS 2980

SERVICES LINES NOTE:

ALL SERVICES LINES ARE INDICATIVE AND TO BE CONFIRMED BY OTHERS PRIOR TO CONSTRUCTIONS

SURVEYOR NOTE:

POTHOLING OR SCANNING SURVEY NEEDED.

PRINTING NOTE:

THIS DRAWING TO BE PRINTED IN COLOUR.

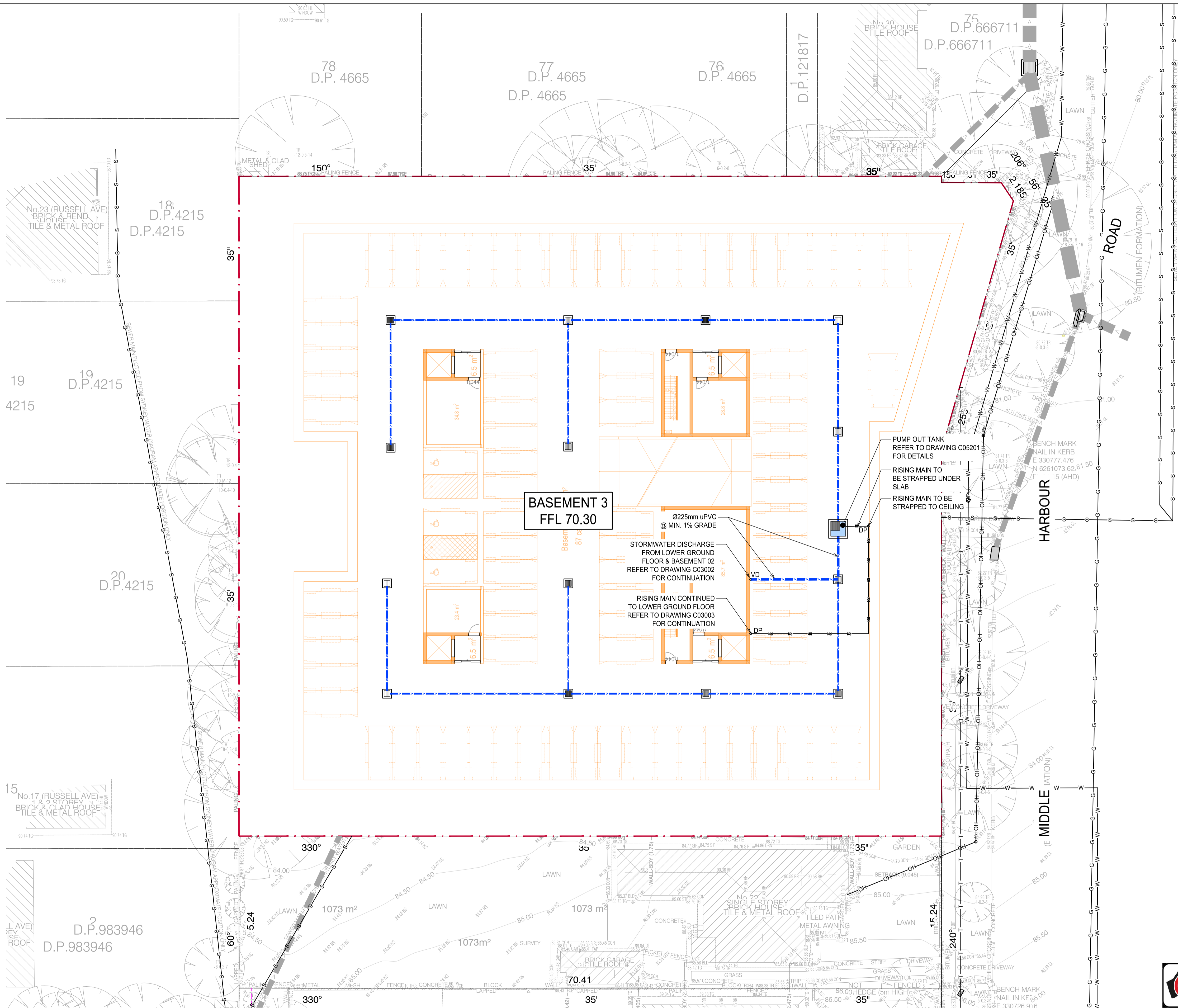

A1 1 2 3 4 5 6 7 8 9 10 11 12 13 14 15 16 17 18 19 20 1:200

Rev	Description	Eng	Draft	Date
1	ISSUE FOR DEVELOPMENT APPLICATION	AH	AH	07.05.2025



T : 02 8810 5800 E : info@xavierknight.com.au
A : Level 7, 210 Clarence Street, Sydney NSW 2000
xavierknight.com.au
This drawing is copyright and is the property of XAVIER KNIGHT CONSULTING ENGINEERS Pty. Ltd. and must not be used without authorisation.

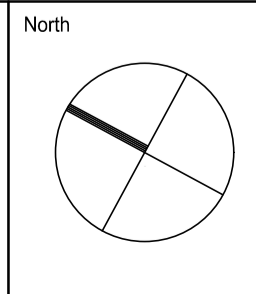

Project
RESIDENTIAL DEVELOPMENT
24, 26 & 28 MIDDLE HARBOUR ROAD, LINDFIELD

Sheet Subject
CIVIL WORKS PLAN - BASEMENT 03













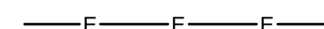
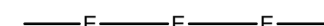
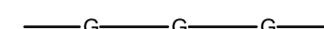

Scale at A1	Drawn	Approved
1:200	AH	FC
Job No	Drawing No	Revision
250213	C03001	1



NOT TO BE USED FOR CONSTRUCTION

DEVELOPMENT APPLICATION

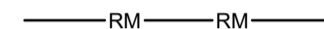
LEGEND

-  SITE BOUNDARY
LIMIT OF WORKS
-  SURVEY. REFER TO DRAWINGS BY
CMS SURVEYORS PTY LTD, ISSUE 1,
DATED 13/08/2024
-  ARCHITECTURAL LAYOUT BY DKO
-  EXISTING ELECTRICAL LINE
-  EXISTING ELECTRICAL LINE
-  EXISTING GAS LINE
-  EXISTING TELECOMMUNICATION LINE
-  EXISTING SEWER LINE
-  EXISTING WATER LINE
-  EXISTING OVERHEAD POWER LINE
-  OUTLINE OF LEVEL BELOW
-  EXISTING STORMWATER PIPE FROM BYDA
CONTRACTOR TO CONFIRM LEVELS &
LOCATION ON SITE PRIOR TO COMMENCEMENT
OF WORKS
-  PROPOSED Ø150mm uPVC STORMWATER
PIPE @ MIN. 1% GRADE U.N.O.
-  STORMWATER RISING MAIN PIPE
-  600 X 600 HEEL SAFE GRATED SURFACE INLET PIT (G.S.I.P.)
U.N.O.
-  DOWN PIPE OUTLET
-  VERTICAL DROPPER

NOTES:

1. ALL EXISTING UTILITY & SERVICES INFORMATION TO BE VERIFIED BY CONTRACTOR PRIOR TO COMMENCEMENT OF WORKS
2. ALL EXISTING STORMWATER PITS & PIPES' LOCATION TO BE CONFIRMED BY DETAILED SURVEY PRIOR TO DETAILED DESIGN STAGE
3. ALL STORMWATER PIPES TO BE STRAPPED TO UNDERSIDE OF SLABS U.N.O.
4. ALL STORMWATER PIPES TO BE MIN. Ø150mm uPVC AT MIN. 1% GRADE TO PITS U.N.O.
5. ALL STORMWATER GRATED ACCESS LIDS TO BE HEEL SAFE
6. ALL STORMWATER PIT LIDS TO MEET REQUIREMENTS OF AS3996 AS SPECIFIED IN DRAWING C00001
7. ALL SLABS TO BE AT MIN. 1% GRADE TO INLET PITS
8. REFER TO DRAWING C05301 FOR ON-SITE DETENTION (OSD) TANK DETAILS
9. REFER TO FLOOD IMPACT ASSESSMENT REPORT FOR PROPOSED FLOOD MITIGATION STRATEGY DETAILS

PIPE NOTE:

ALL PIPES ARE Ø150mm uPVC @ MIN. 1% GRADE & STRAPPED UNDERNEATH THE BASEMENT SLAB

SLAB NOTE:

SLAB TO BE GRADED AT MIN. 1% GRADE TOWARDS PITS TO MEET REQUIREMENTS OF AS 2980

SERVICES LINES NOTE:

ALL SERVICES LINES ARE INDICATIVE AND TO BE CONFIRMED BY OTHERS PRIOR TO CONSTRUCTIONS

SURVEYOR NOTE:

POTHOLING OR SCANNING SURVEY NEEDED.

PRINTING NOTE:

THIS DRAWING TO BE PRINTED IN COLOUR.

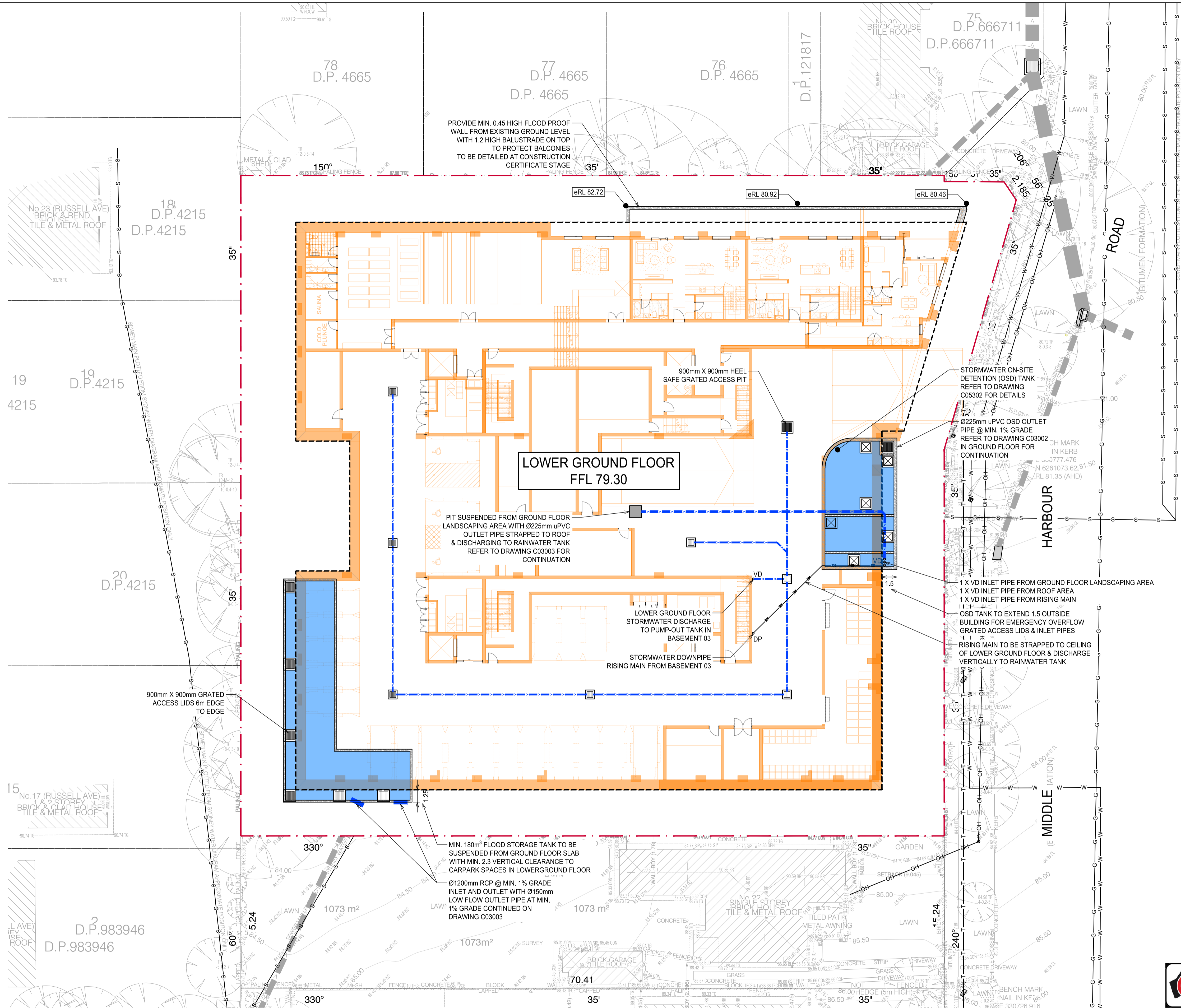

A1 1 2 3 4 5 6 7 8 9 10 11 12 13 14 15 16 17 18 19 20 21 22 23 24 25 26 27 28 29 30 31 32 33 34 35 36 37 38 39 40 41 42 43 44 45 46 47 48 49 50 51 52 53 54 55 56 57 58 59 60 61 62 63 64 65 66 67 68 69 70 71 72 73 74 75 76 77 78 79 80 81 82 83 84 85 86 87 88 89 90 91 92 93 94 95 96 97 98 99 100 1:200

1	ISSUE FOR DEVELOPMENT APPLICATION	AH	AH	07.05.2025
Rev	Description	Eng	Draft	Date



T : 02 8810 5800 E : info@xavierknight.com.au
A : Level 7, 210 Clarence Street, Sydney NSW 2000
xavierknight.com.au
This drawing is copyright and is the property of XAVIER KNIGHT CONSULTING ENGINEERS Pty. Ltd. and must not be used without authorisation.

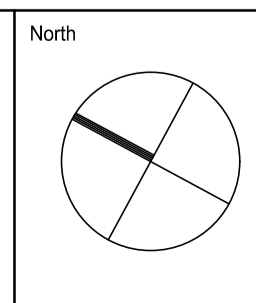

Project
RESIDENTIAL DEVELOPMENT
24, 26 & 28 MIDDLE HARBOR ROAD, LINDFIELD

Sheet Subject
CIVIL WORKS PLAN - LOWER GROUND FLOOR

Scale at A1 1:200	Drawn AH	Approved FC
Job No 250213	Drawing No C03002	Revision 1



NOT TO BE USED FOR CONSTRUCTION

DEVELOPMENT APPLICATION

LEGEND

- SITE BOUNDARY
- LIMIT OF WORKS
- SURVEY. REFER TO DRAWINGS BY CMS SURVEYORS PTY LTD, ISSUE 1, DATED 13/08/2024
- LANDSCAPE DESIGN BY LANDFORM
- ARCHITECTURAL LAYOUT BY DKO
- EXISTING ELECTRICAL LINE
- EXISTING GAS LINE
- EXISTING TELECOMMUNICATION LINE
- EXISTING SEWER LINE
- EXISTING WATER LINE
- EXISTING OVERHEAD POWER LINE
- OUTLINE OF LEVEL BELOW
- EXISTING STORMWATER PIPE FROM BYDA CONTRACTOR TO CONFIRM LEVELS & LOCATION ON SITE PRIOR TO COMMENCEMENT OF WORKS
- PROPOSED Ø1200mm RCP STORMWATER PIPE @ MIN. 1% GRADE U.N.O.
- STORMWATER RISING MAIN PIPE
- 900 X 900 HEEL SAFE GRATED SURFACE INLET PIT (G.S.I.P.) U.N.O.
- 900 X 900 PAVER INFILL SEALED LIDS TO BE DETAILED BY LANDSCAPE ARCHITECT AT CONSTRUCTION CERTIFICATE STAGE
- VERTICAL DROPPER
- ROCK LINED SWALE REFER TO DRAWING C09001 FOR DETAILS
- EXISTING TREES TO REMAIN REFER TO ARBORIST REPORT
- EXISTING TREES TO BE REMOVED REFER TO ARBORIST REPORT
- PROPOSED TREES REFER TO ARBORIST REPORT

NOTES:

1. ALL EXISTING UTILITY & SERVICES INFORMATION TO BE VERIFIED BY CONTRACTOR PRIOR TO COMMENCEMENT OF WORKS
2. ALL EXISTING STORMWATER PITS & PIPES' LOCATION TO BE CONFIRMED BY DETAILED SURVEY PRIOR TO DETAILED DESIGN STAGE
3. ALL STORMWATER PIPES TO BE STRAPPED TO UNDERSIDE OF SLABS U.N.O.
4. ALL STORMWATER PIPES TO BE MIN. Ø1200mm uPVC AT MIN. 1% GRADE TO PITS U.N.O.
5. ALL STORMWATER GRATED ACCESS LIDS TO BE HEEL SAFE
6. ALL STORMWATER PIT LIDS TO MEET REQUIREMENTS OF AS3996 AS SPECIFIED IN DRAWING C00001
7. ALL OUTDOOR AREAS TO BE GRADED AT MIN. 1% GRADE TO INLET PITS
8. REFER TO DRAWING C03002 FOR FLOOD STORAGE TANK DETAILS
9. REFER TO DRAWING C05301 FOR ON-SITE DETENTION (OSD) TANK DETAILS
10. REFER TO FLOOD IMPACT ASSESSMENT REPORT FOR PROPOSED FLOOD MITIGATION STRATEGY DETAILS
11. ALL HABITABLE FLOOR LEVELS INCLUDING ACCESS TO HABITABLE AREAS TO BE AT FFL 84.10 OR ABOVE

PIPE NOTE:
ALL PIPES ARE Ø150mm uPVC @ MIN. 1% GRADE & STRAPPED UNDERNEATH THE BASEMENT SLAB

SERVICES LINES NOTE:
ALL SERVICES LINES ARE INDICATIVE AND TO BE CONFIRMED BY OTHERS PRIOR TO CONSTRUCTIONS

SURVEYOR NOTE:
POTHOLING OR SCANNING SURVEY NEEDED.

PRINTING NOTE:
THIS DRAWING TO BE PRINTED IN COLOUR.

PIT SCHEDULE				
PIT No.	PIT WIDTH	PIT LENGTH	LID DIMENSIONS	LID TYPE
	mm	mm	mm	
A1	1500	6000	4 X (1500 X 1500)	GRATED
A2	1500	1500	1500 X 1500	GRATED
A3	1500	1500	1501 X 1500	GRATED
A4	1500	1500	1502 X 1500	GRATED
A5	1500	1500	1503 X 1500	GRATED
A6	1500	1500	1504 X 1500	GRATED
A7	2400	2400	2 X (1200 X 1200)	GRATED
A8	2400	2400	2 X (1200 X 1200)	GRATED

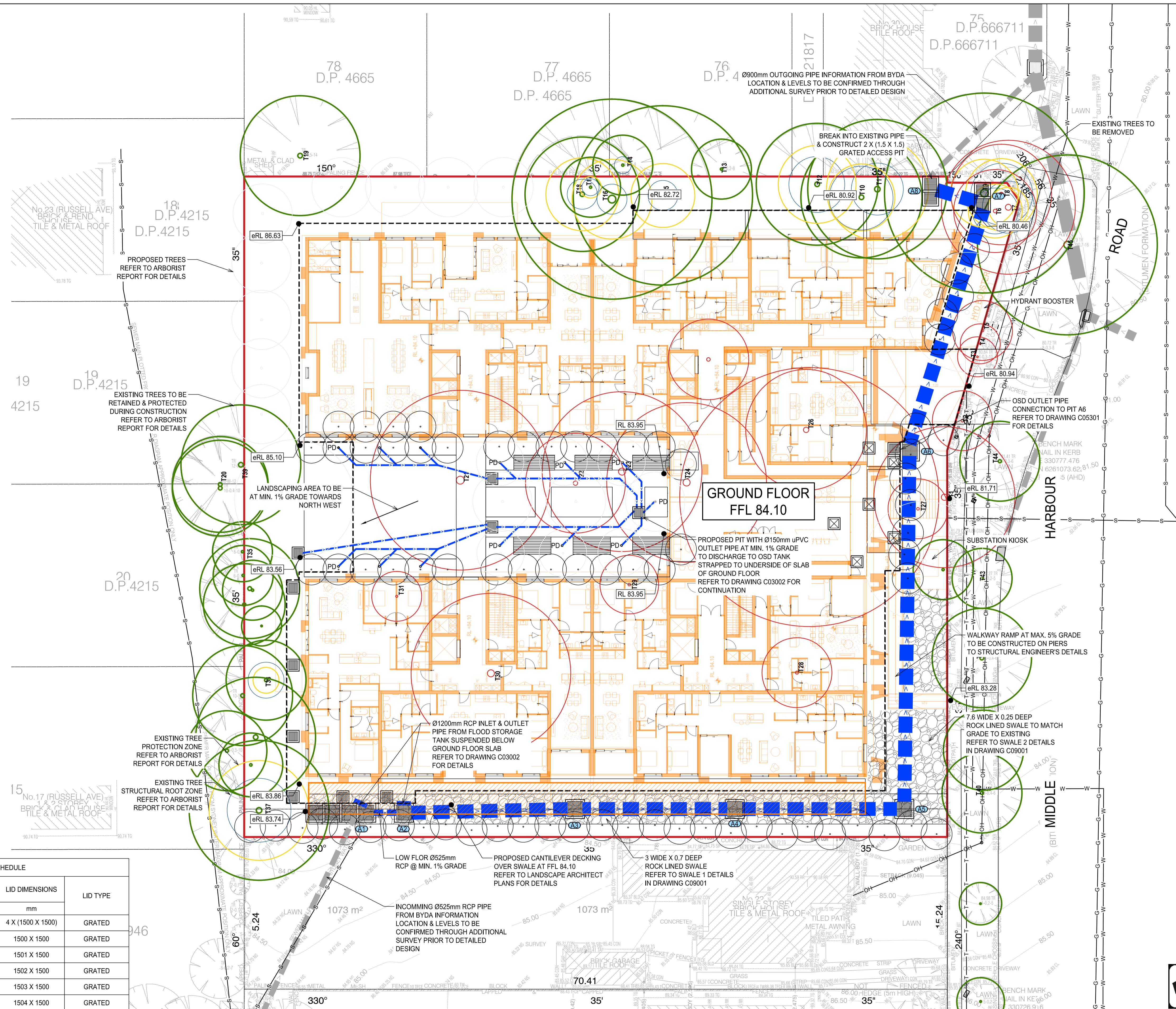

Rev	Description	Eng	Draft	Date
1	ISSUE FOR DEVELOPMENT APPLICATION	AH	AH	07.05.2025



T : 02 8810 5800 E : info@xavierknight.com.au
A : Level 7, 210 Clarence Street, Sydney NSW 2000
xavierknight.com.au
This drawing is copyright and is the property of XAVIER KNIGHT CONSULTING ENGINEERS Pty. Ltd. and must not be used without authorisation.

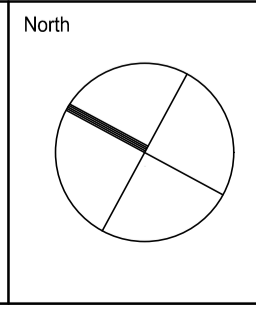

Project
RESIDENTIAL DEVELOPMENT
24, 26 & 28 MIDDLE HARBOUR ROAD, LINDFIELD

Sheet Subject
CIVIL WORKS PLAN - GROUND FLOOR







Scale at A1	Drawn	Approved
1:200	AH	FC
Job No	Drawing No	Revision
250213	C03003	1

DEVELOPMENT APPLICATION

NOT TO BE USED FOR CONSTRUCTION



LEGEND

-  ROOF AREA TO OSD
0.312 ha
-  PAVED AREA TO OSD
0.016 ha
-  LANDSCAPING PERVIOUS
AREA TO OSD
0.032 ha
-  BYPASS 1 - PERVIOUS AREA
0.056 ha
-  BYPASS 2 - IMPERVIOUS AREA
0.013 ha
-  BYPASS 2 - PERVIOUS AREA
0.047 ha

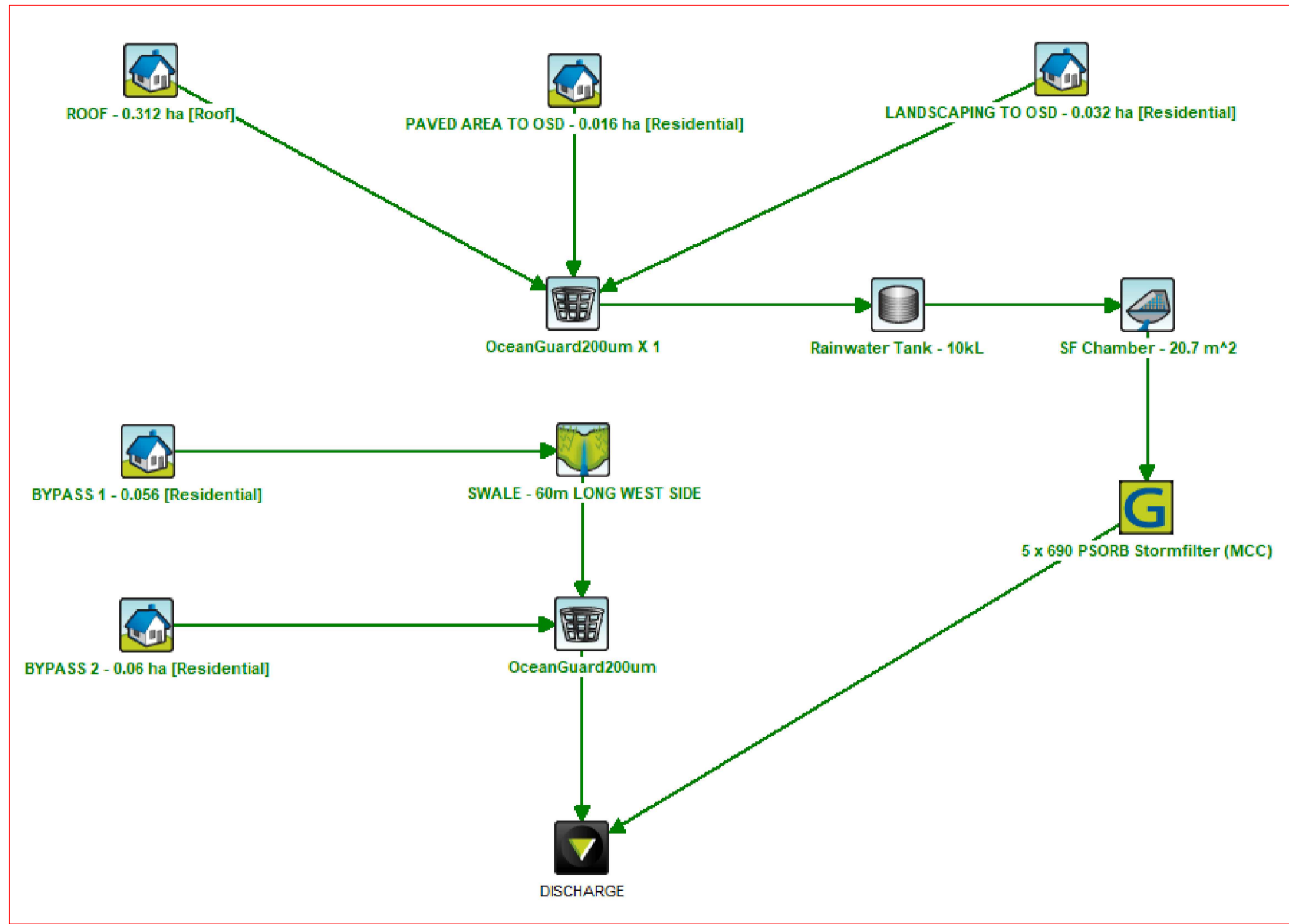

MUSIC MODEL
REFER TO MUSIC LINK REPORT

STORMWATER QUALITY - MUSIC MODEL RESULT SUMMARY		
POLLUTANT TYPES	REDUCTION TARGETS (%)	REDUCTION TARGET ACHIEVED (%)
TOTAL SUSPENDED SOLIDS (TSS)	85.0	85.8
TOTAL PHOSPHORUS (TP)	65.0	69.1
TOTAL NITROGEN (TN)	45.0	51.5
GROSS POLLUTANTS (GP)	70.0	100.0

SERVICES LINES NOTE:
ALL SERVICES LINES ARE INDICATIVE AND TO BE CONFIRMED BY OTHERS PRIOR TO CONSTRUCTIONS

SURVEYOR NOTE:
POTHOLING OR SCANNING SURVEY NEEDED.

PRINTING NOTE:
THIS DRAWING TO BE PRINTED IN COLOUR.

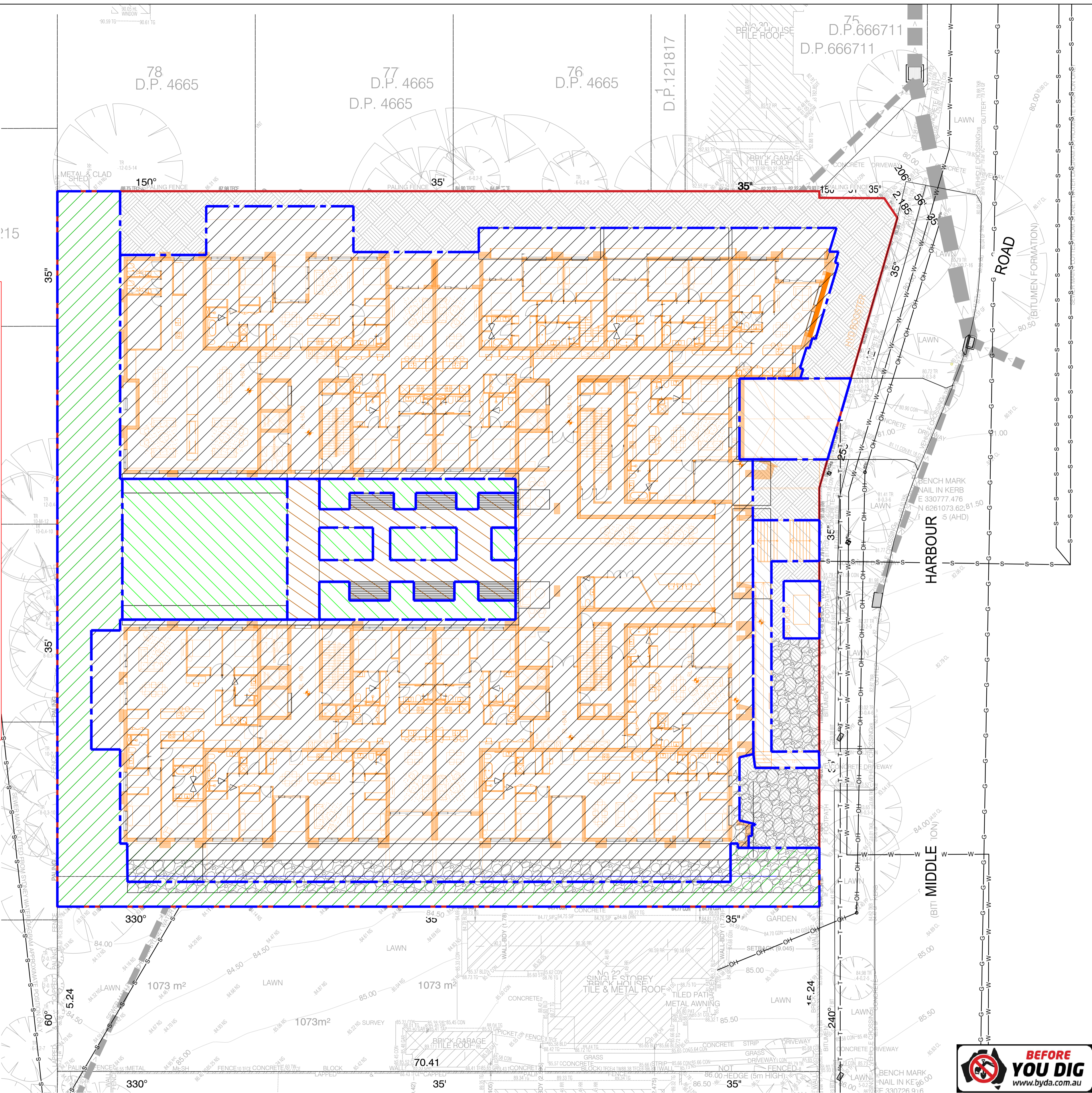

NOT TO BE USED FOR CONSTRUCTION

DEVELOPMENT APPLICATION

A1 1 2 3 4 5 6 7 8 9 10 11 12 13 14 15 16 17 18 19 20 1:200

Rev	Description	Eng	Draft	Date
1	ISSUE FOR DEVELOPMENT APPLICATION	AH	AH	07.05.2025



T : 02 8810 5800 E : info@xavierknight.com.au
A : Level 7, 210 Clarence Street, Sydney NSW 2000
xavierknight.com.au
This drawing is copyright and is the property of XAVIER KNIGHT CONSULTING ENGINEERS Pty. Ltd. and must not be used without authorisation.

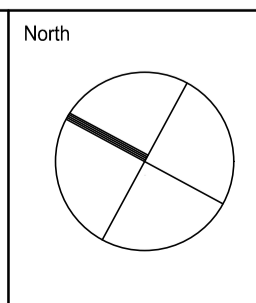

Project
RESIDENTIAL DEVELOPMENT
24, 26 & 28 MIDDLE HARBOUR ROAD, LINDFIELD

Sheet Subject
WATER SENSITIVE URBAN DESIGN PLAN & DETAILS

Scale at A1	Drawn	Approved
1:200	AH	FC
Job No	Drawing No	Revision
250213	C05101	1

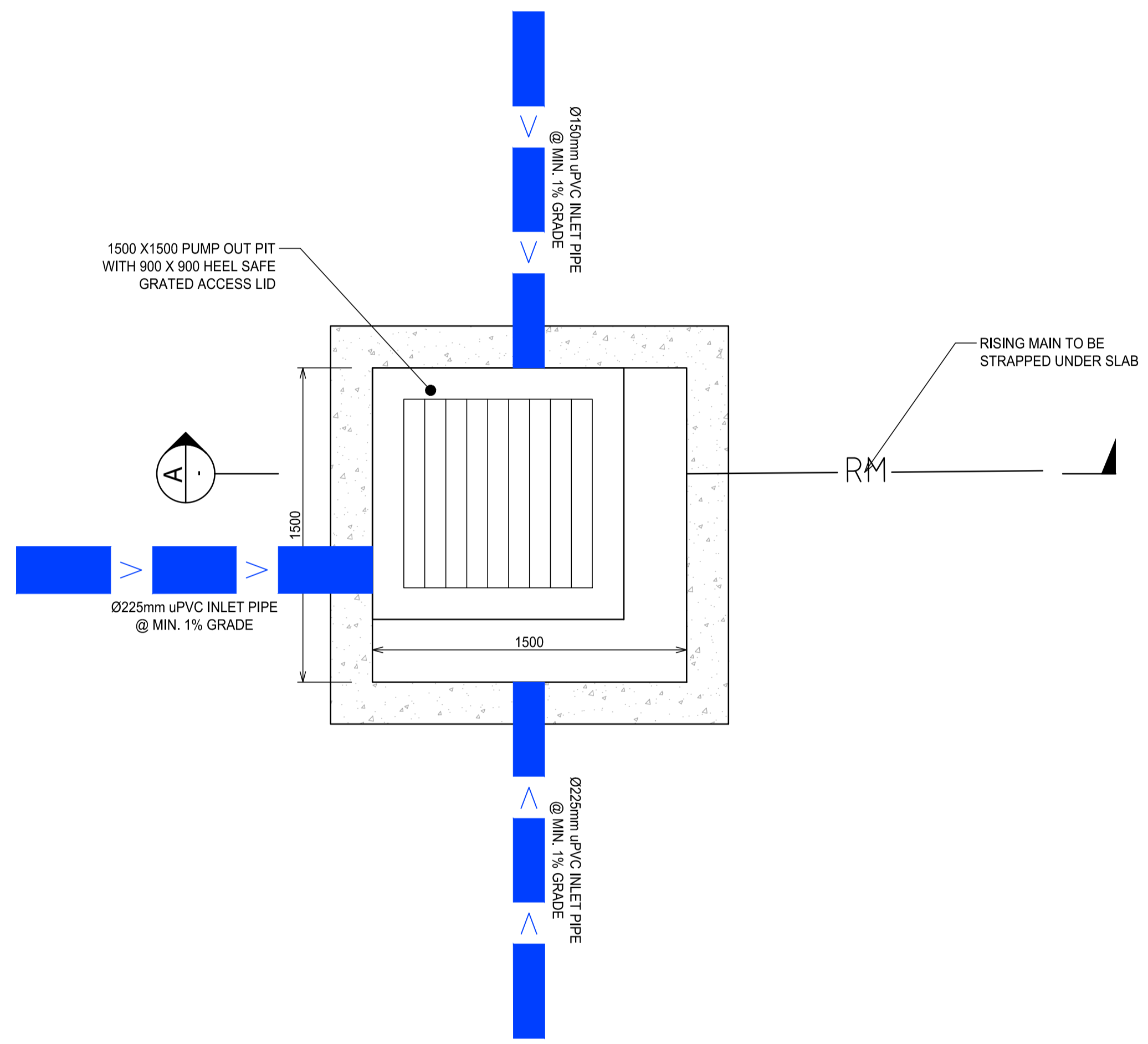

PUMP OUT PIT - PLAN
SCALE 1:20

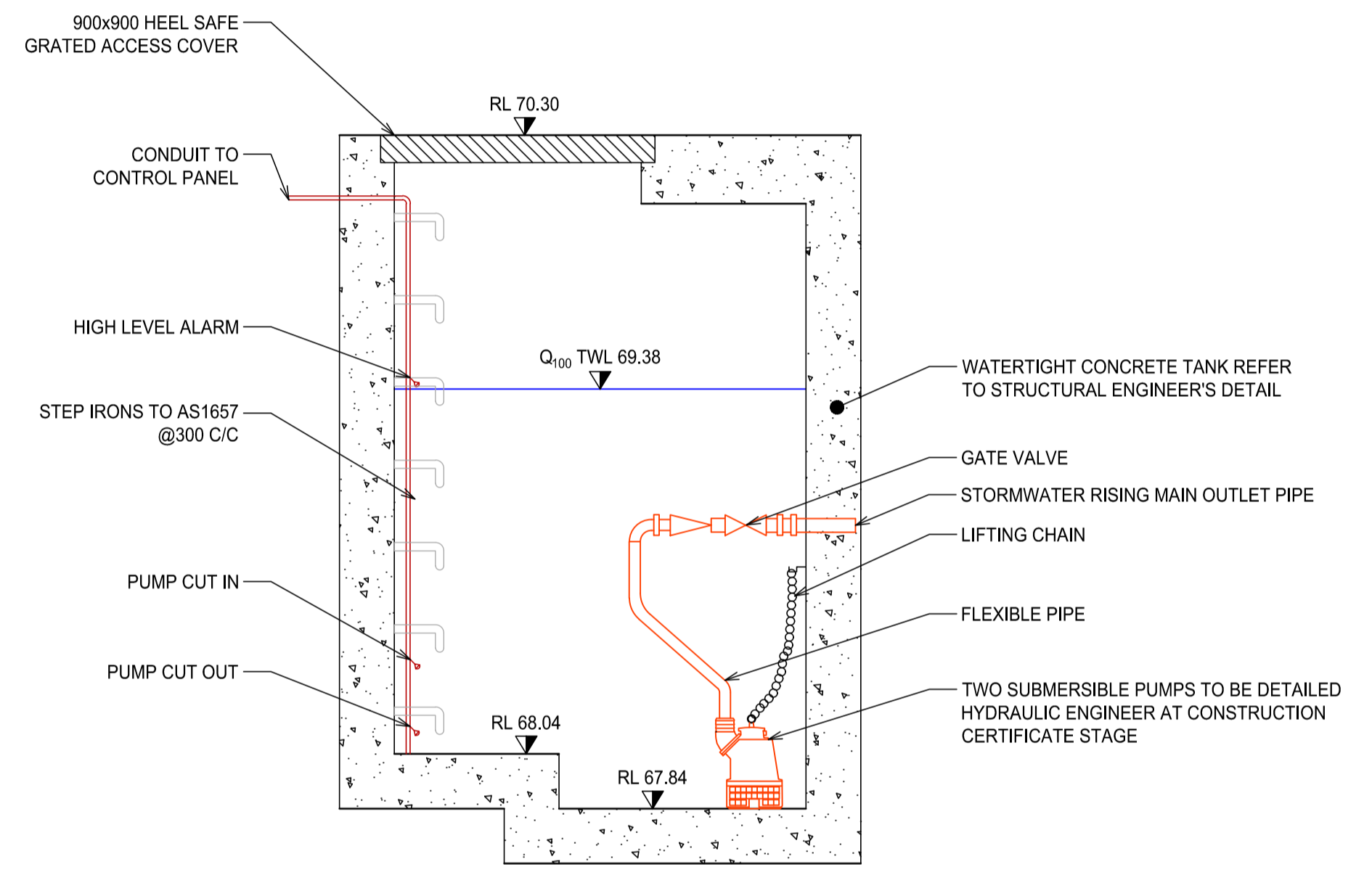

A SECTION
SCALE 1:20

PRINTING NOTE:
THIS DRAWING TO BE PRINTED IN COLOUR.

1	ISSUE FOR DEVELOPMENT APPLICATION	AH	TR	07.05.2025
Rev	Description	Eng	Draft	Date



T : 02 8810 5800 E : info@xavierknight.com.au
A : Level 7, 210 Clarence Street, Sydney NSW 2000
xavierknight.com.au
This drawing is copyright and is the property of XAVIER KNIGHT CONSULTING ENGINEERS Pty. Ltd. and must not be used without authorisation.

Project	RESIDENTIAL DEVELOPMENT 24, 26 & 28 MIDDLE HARBOUR ROAD, LINDFIELD
Sheet Subject	STORMWATER PUMP OUT PIT DETAILS - SHEET 1

Scale at A1	1:20	Drawn	TR	Approved	FC
Job No	250213	Drawing No	C05201	Revision	1



NOT TO BE USED FOR CONSTRUCTION

DEVELOPMENT APPLICATION

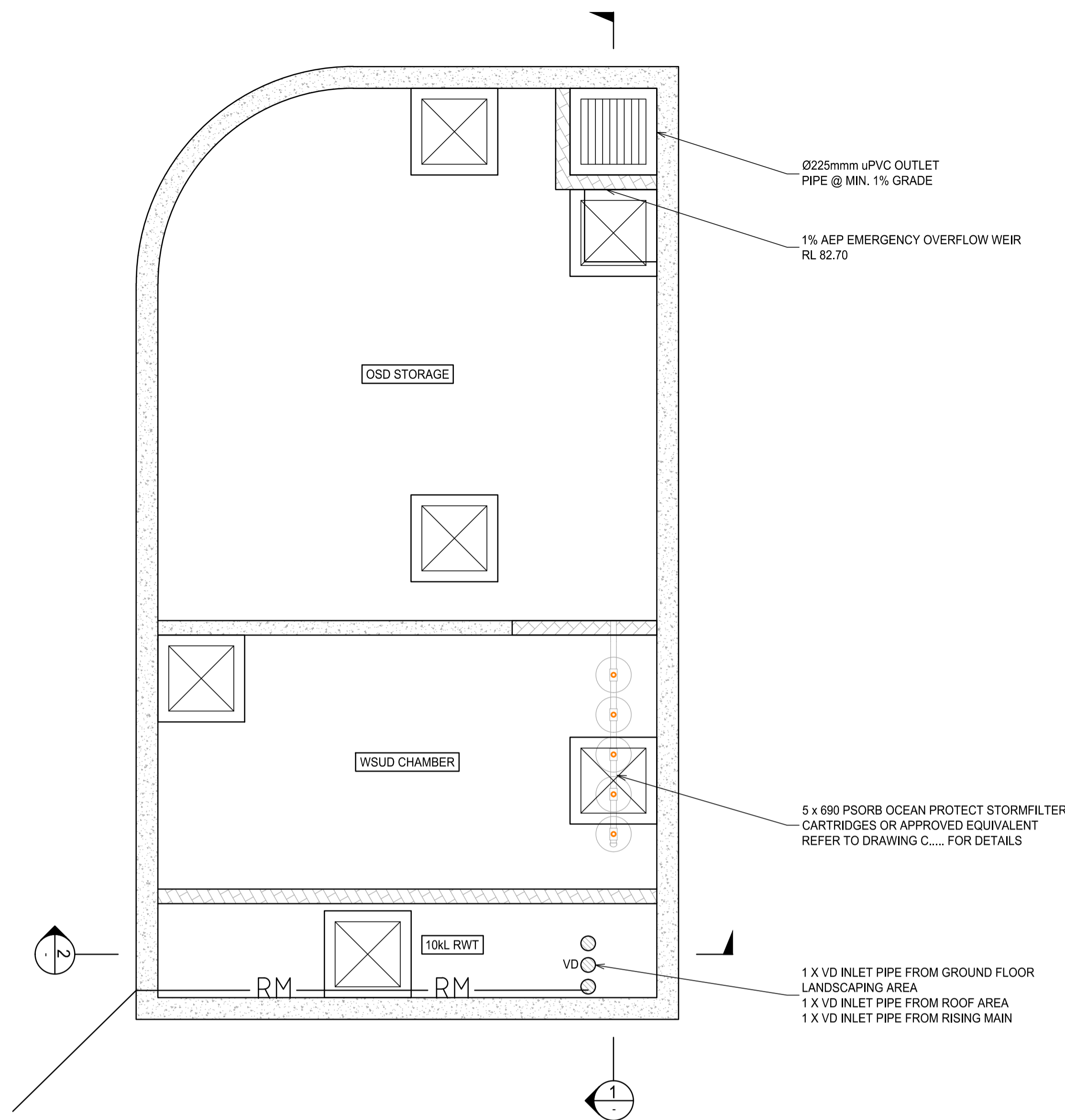

ON-SITE DETENTION TANK - PLAN
SCALE 1:50

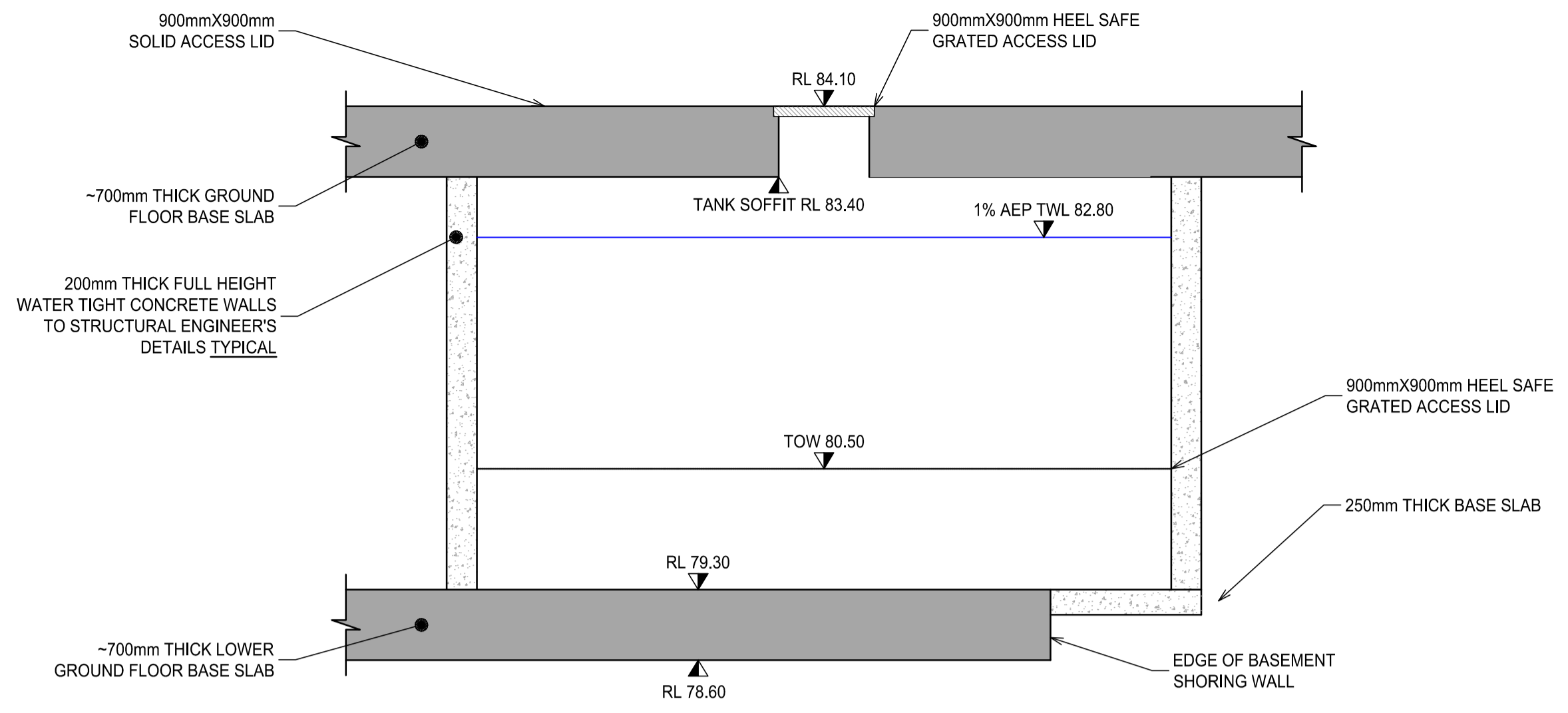

SECTION 1
SCALE 1:50

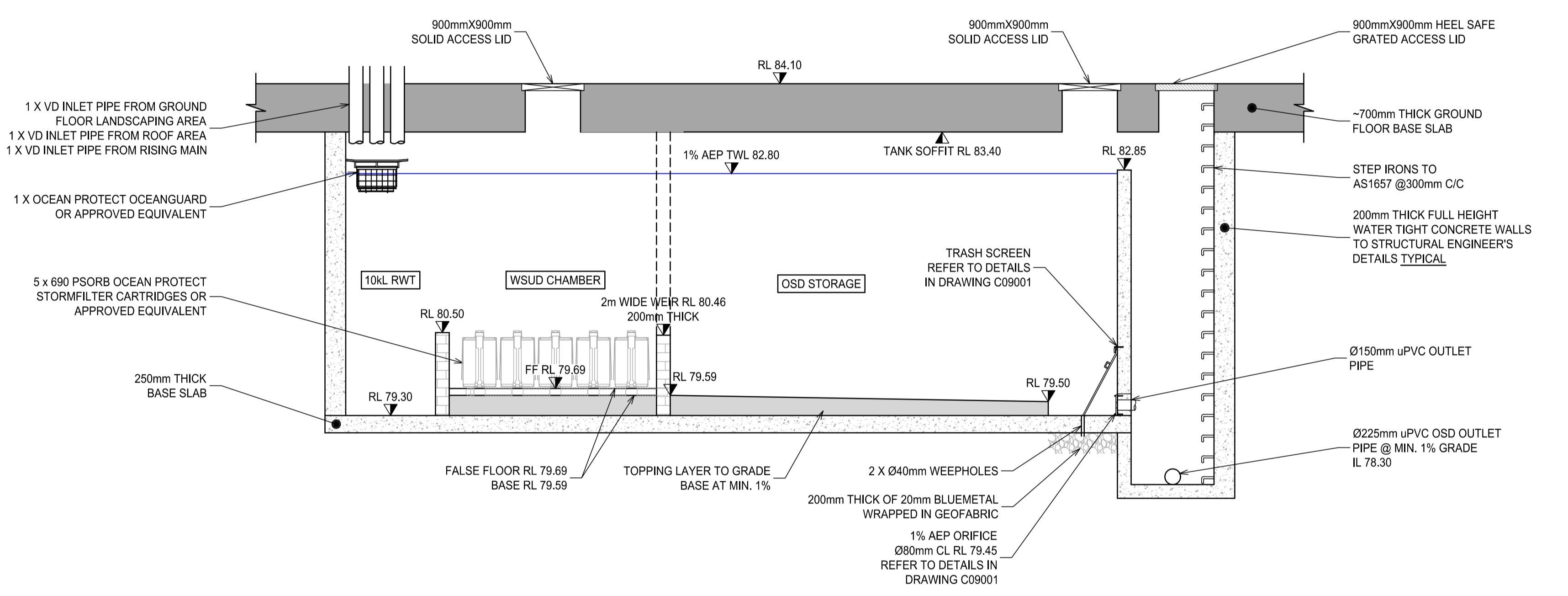

SECTION 2
SCALE 1:50

NOTES:

1. ALL EXISTING STORMWATER PITS & PIPES' LOCATION TO BE CONFIRMED BY DETAILED SURVEY PRIOR TO DETAILED DESIGN STAGE
2. ALL STORMWATER PIPES TO BE STRAPPED TO UNDERSIDE OF SLABS U.N.O.
3. ALL STORMWATER PIPES TO BE MIN. Ø150mm uPVC AT MIN. 1% GRADE TO PITS U.N.O.
4. ALL STORMWATER GRATED ACCESS LIDS TO BE HEEL SAFE
5. ALL STORMWATER PIT LIDS TO MEET REQUIREMENTS OF AS3996 AS SPECIFIED IN DRAWING C00001

OSD CALCULATIONS:

SITE AREA	4,757 m ²
BYPASS AREA / UNDISTURBED	1,785 m ²
EFFECTIVE SITE AREA OF DEVELOPMENT	2,972 m ²

STORAGE & DISCHARGE REQUIREMENTS BELOW HAVE BEEN CALCULATED USING KU RING GAI COUNCIL'S DEVELOPMENT CONTROL PLAN - DCP 47

MAX. PERMISSIBLE SITE DISCHARGE (PSD)	23 L/s
MIN. SITE STORAGE REQUIREMENT (SSR)	54 m ³

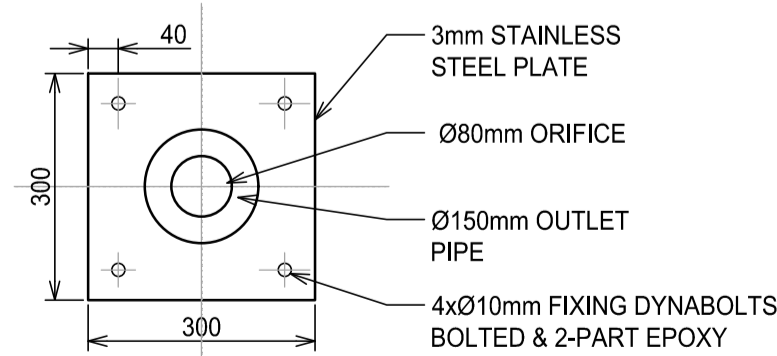

ORIFICE PLATE DETAIL
SCALE 1:10

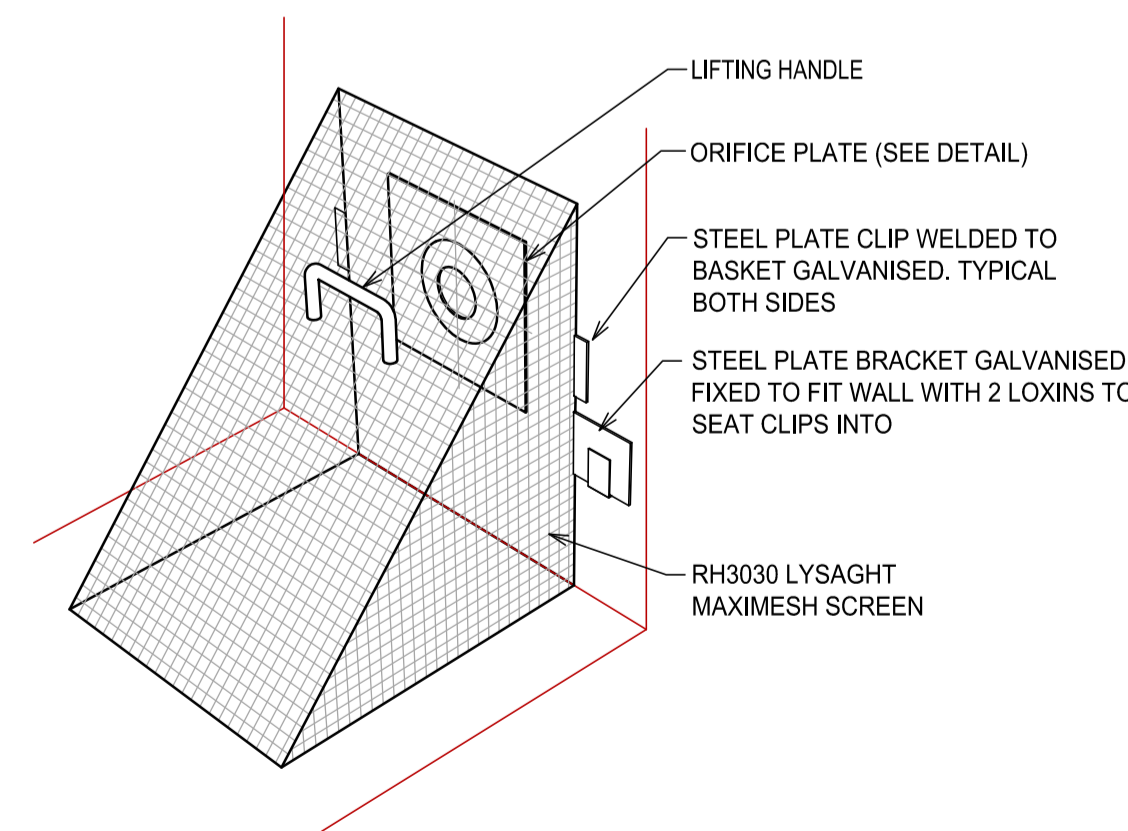

DEBRIS SCREEN
NOT TO SCALE

PRINTING NOTE:
THIS DRAWING TO BE PRINTED IN COLOUR.



NOT TO BE USED FOR CONSTRUCTION

DEVELOPMENT APPLICATION

A1 0 0.5 1.0 1.5 2.0 2.5 3.0 3.5 4.0 4.5 5.0 5.5 6.0 6.5 7.0 7.5 8.0 8.5 9.0 9.5 10.0 1:10

2	ISSUE FOR DEVELOPMENT APPLICATION	AH	AH	08.05.2025
1	ISSUE FOR DEVELOPMENT APPLICATION	AH	AH / TR	07.05.2025
Rev	Description	Eng	Draft	Date



T : 02 8810 5800 E : info@xavierknight.com.au
A : Level 7, 210 Clarence Street, Sydney NSW 2000
xavierknight.com.au
This drawing is copyright and is the property of XAVIER KNIGHT CONSULTING ENGINEERS Pty. Ltd. and must not be used without authorisation.

North	Project RESIDENTIAL DEVELOPMENT 24, 26 & 28 MIDDLE HARBOUR ROAD, LINDFIELD	Scale at A1 AS SHOWN	Drawn AH / TR	Approved FC
	Sheet Subject STORMWATER DETENTION TANK DETAILS - SHEET 1	Job No 250213	Drawing No C05301	Revision 1

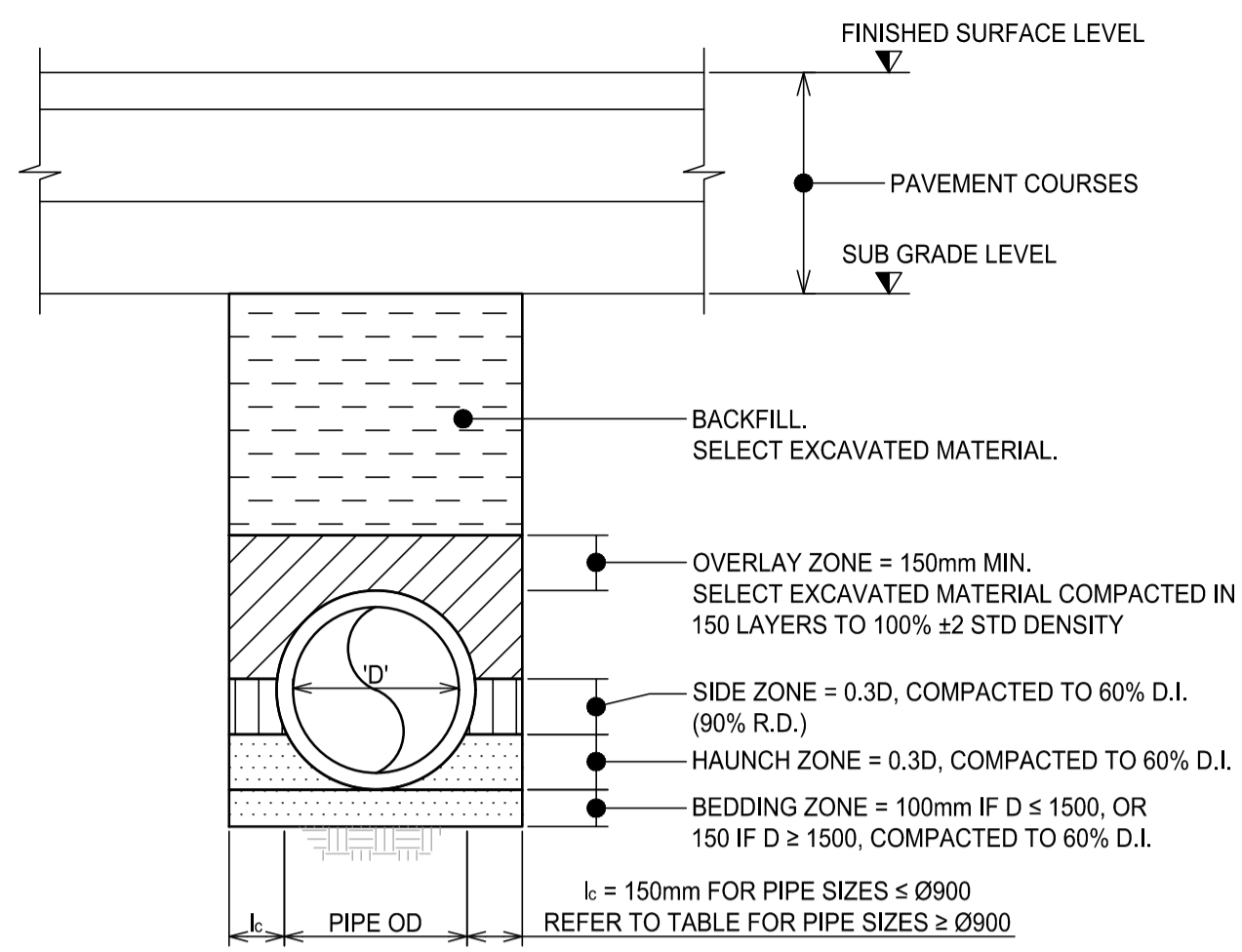

TYPE HS2 SUPPORT TO CONCRETE PIPES UNDER PAVEMENT

SCALE 1:20
D ≤ 1350, MAX FILL = 4.0m
D ≥ 1350, MAX FILL = 3.0m

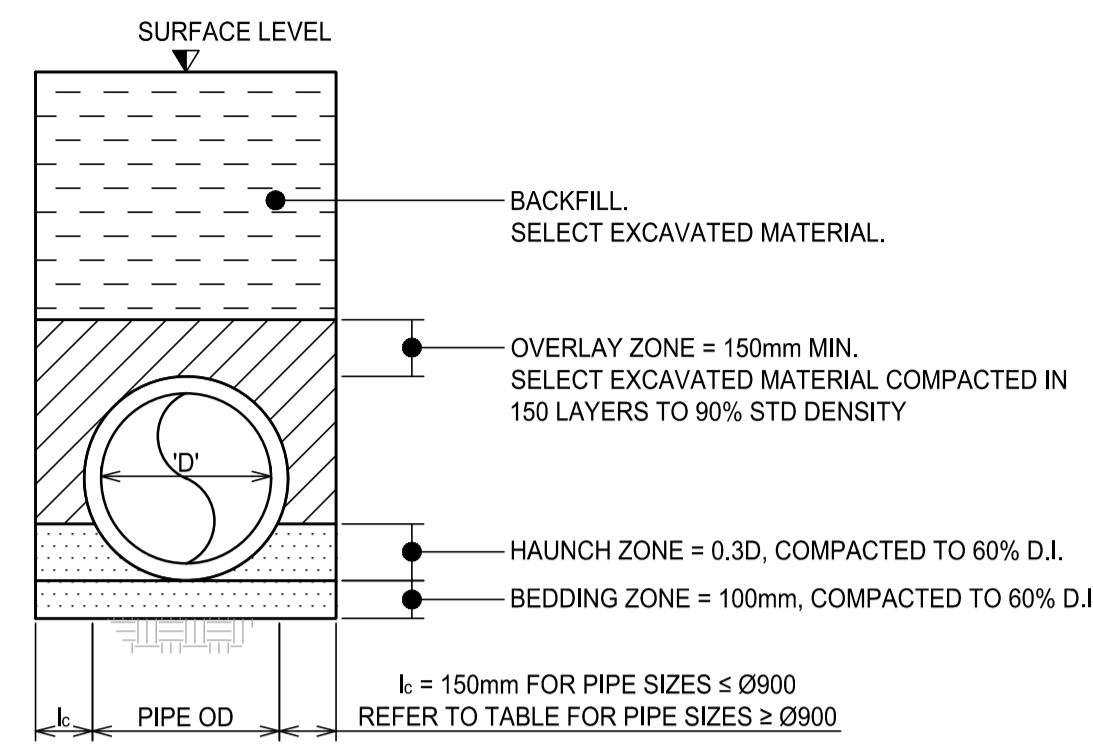

TYPE H1 SUPPORT TO CONCRETE PIPES AT LANDSCAPE AREAS

SCALE 1:20

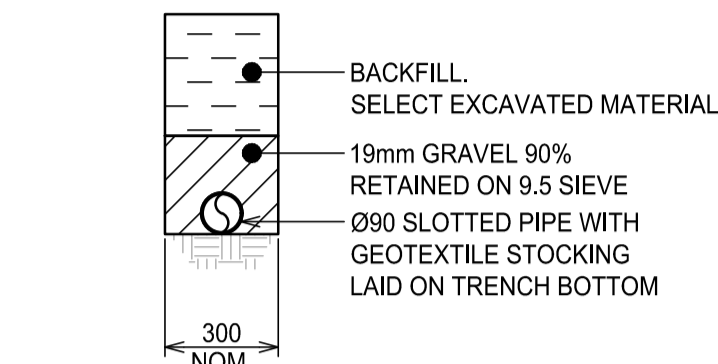

SUPPORT TO SUBSOIL PIPE

SCALE 1:20

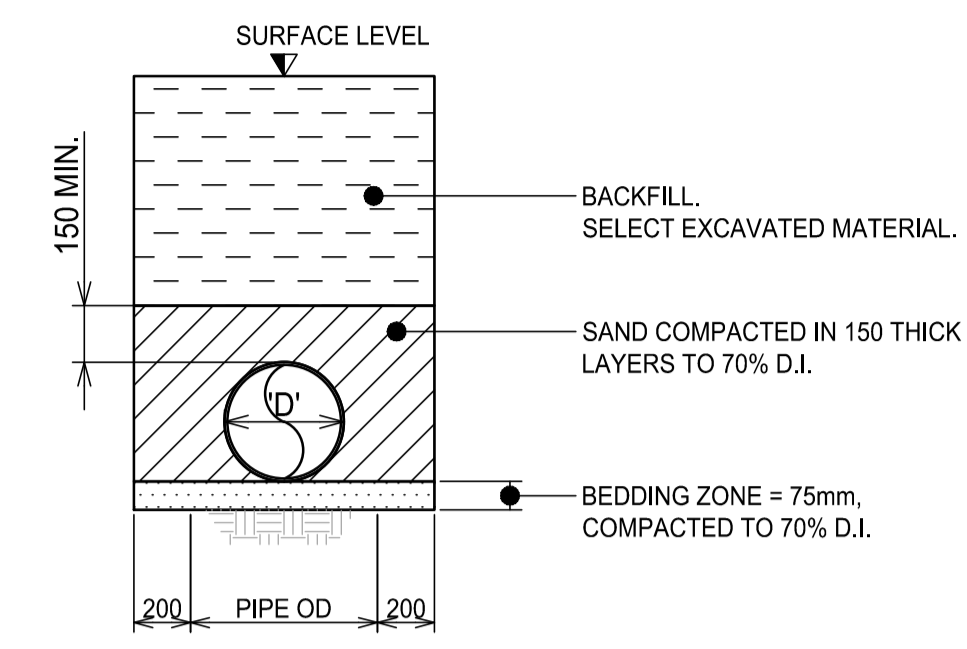

SUPPORT TO uPVC PIPES

SCALE 1:20

BEDDING AND HAUNCH MATERIAL GRADING	
SIEVE SIZE (mm)	WEIGHT PASSING (%)
19	100
2.36	100 - 50
0.60	90 - 20
0.30	60 - 10
0.15	25 - 0
0.075	10 - 0

SIDE ZONE MATERIAL GRADING	
SIEVE SIZE (mm)	WEIGHT PASSING (%)
75	100
9.5	100 - 50
2.36	100 - 30
0.60	50 - 15
0.075	25 - 0

SIDE ZONE WIDTH	
PIPE SIZE (mm)	l _c (mm)
≤ Ø900	150
Ø1050	175
Ø1200	200
Ø1350	225
Ø1500	250
Ø1650	275
Ø1800	300

NOTE: REFER TO ENGINEER TO TRENCH WIDTHS FOR PIPE SIZES > Ø1800

NOTE: SELECT FILL MATERIAL IN ACCORDANCE WITH TABLE 1 OF AS 3725

NOTE: ALL ROCKS LARGER THAN 150mm IN OVERLAY ZONES ARE TO BE REMOVED. A MAXIMUM OF 20% OF MATERIAL TO BE 75-150mm PARTICLE SIZE.

PIPE LAYING DETAILS

SCALE 1:20

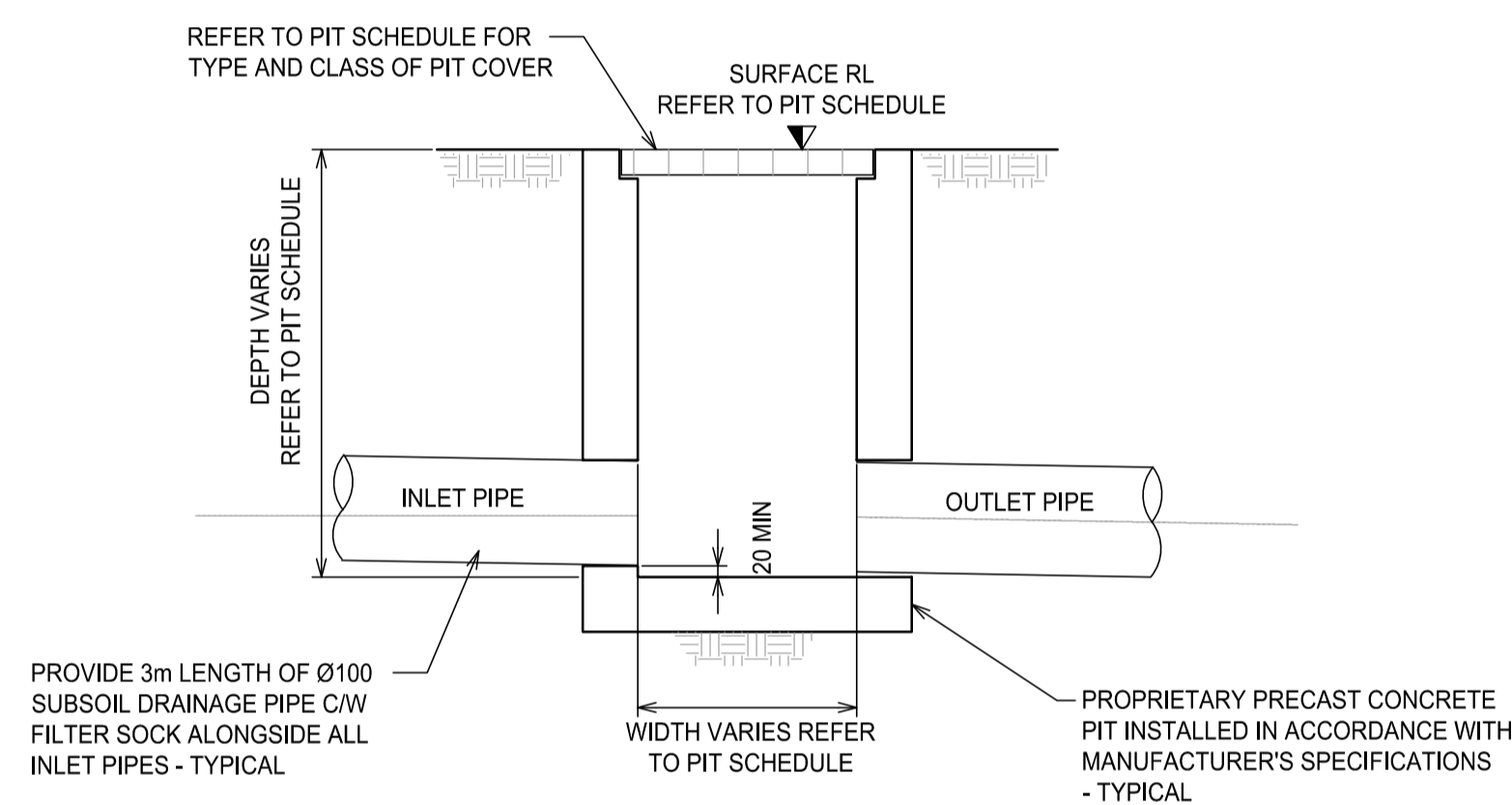
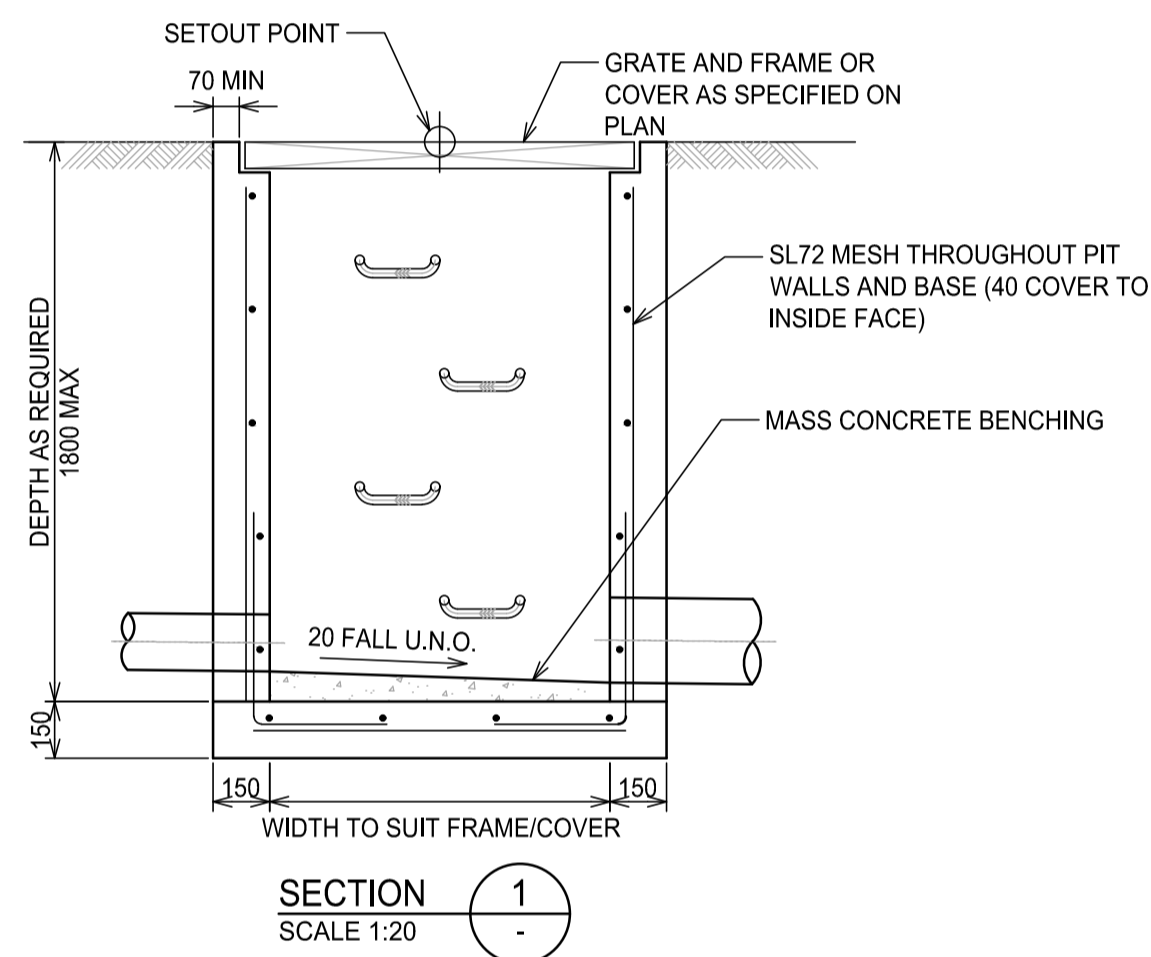

STORMWATER DRAINAGE PIT - PRECAST PIT

SCALE 1:20

TABLE 1	
SIEVE SIZE (mm)	WEIGHT PASISNG (%)
75.0	100
9.5	100 TO 50
2.36	100 TO 30
0.60	50 TO 15
0.075	25 TO 0

TABLE 2	
SIEVE SIZE (mm)	WEIGHT PASISNG (%)
19.0	100
2.36	100 TO 50
0.60	90 TO 20
0.30	60 TO 10
0.15	25 TO 0
0.075	10 TO 0

TABLE 3				
SUPPORT TYPE	BED ZONE X	HAUNCH ZONE Y	BED AND HAUNCH ZONES COMPACTION	MAX BEDDING FACTOR
HS1		0.1D	50	2.0
HS2	100 IF D<=1500, OR 150 IF D>=1500	0.3D	60	2.5
HS3		0.3D	70	4.0

TYPICAL PIT CHAMBER SIZES

IT IS THE CONTRACTOR'S RESPONSIBILITY TO SELECT PIT CHAMBER SIZE WITH REGARDS TO PIPE SIZE, DEPTH TO INVERT AND SKEW ANGLE. REFER SKETCHES BELOW.

- SELECT PIT CHAMBER USING THE STEPS BELOW:
- SELECT PIT CHAMBER SIZE DEPENDING ON THE PIPE DIAMETERS.
- CHECK PIT CHAMBER SIZE TO SATISFY DEPTH TO INVERT REQUIREMENTS. CHECK PIT CHAMBER DIMENSIONS TO SATISFY THE SKEW ANGLE IN THE TABLE.

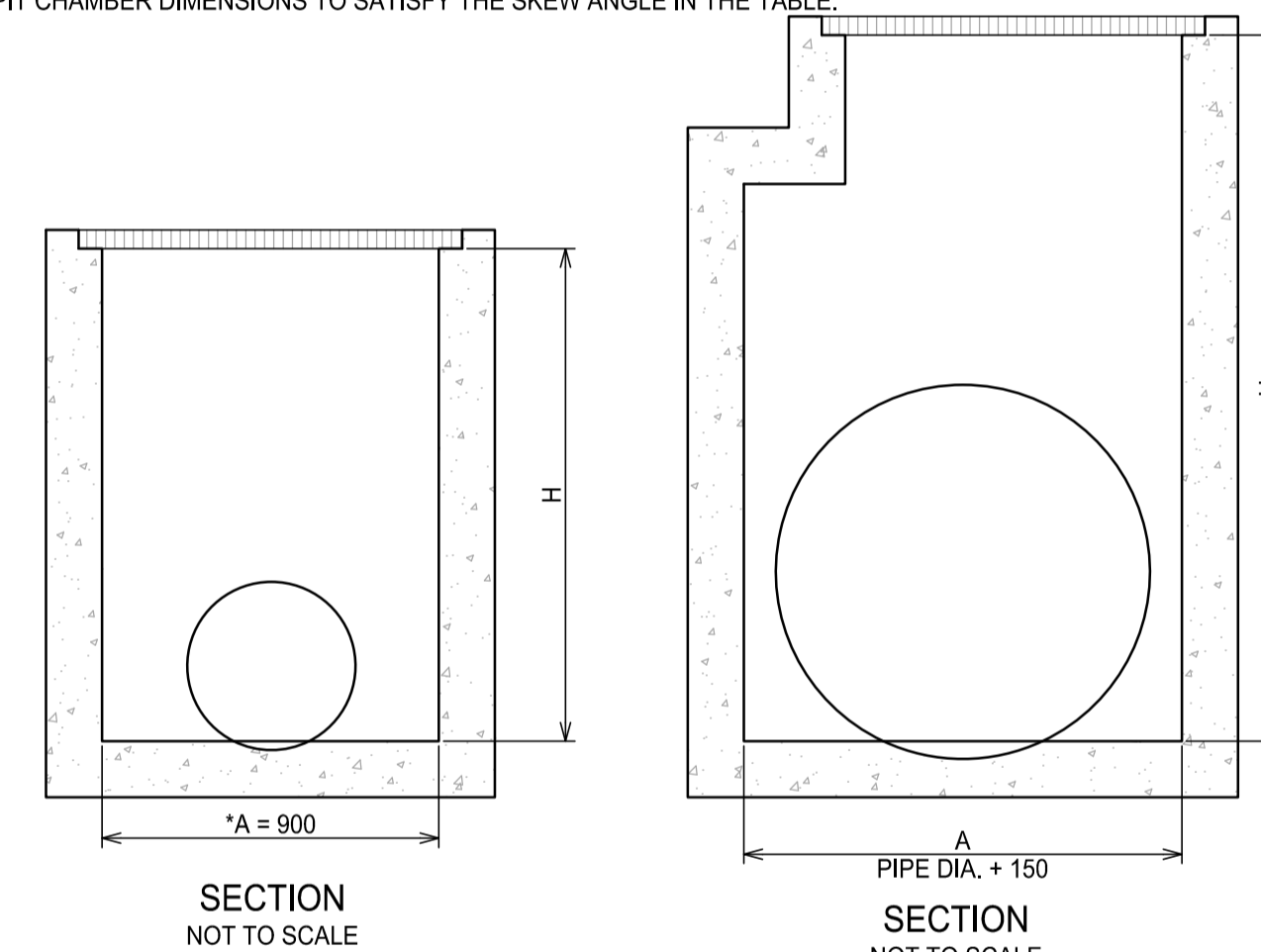

*A = 600 FOR PIPES UP TO 375 DIA.

① PIT CHAMBER DIMENSIONS FOR PIPES UP TO 600 DIA.

② PIT CHAMBER FOR PIPES GREATER THAN 600 DIA.

FOR B = 600mm - MAX. SIDE ENTRY PIPE AT 45° SKEW = 225mm
FOR B = 900mm - MAX. SIDE ENTRY PIPE AT 45° SKEW = 375mm
FOR B = 1200mm - MAX. SIDE ENTRY PIPE AT 45° SKEW = 600mm
FOR B = 1500mm - MAX. SIDE ENTRY PIPE AT 45° SKEW = 825mm
FOR B = 1900mm - MAX. SIDE ENTRY PIPE AT 45° SKEW = 1050mm

② PIT SIZE & DEPTH REQUIREMENTS

H = 0-900mm - A x B = 600 x 600mm
H = 900-1200mm - A x B = 900 x 600mm
H = >1200mm - A x B = 900 x 900mm

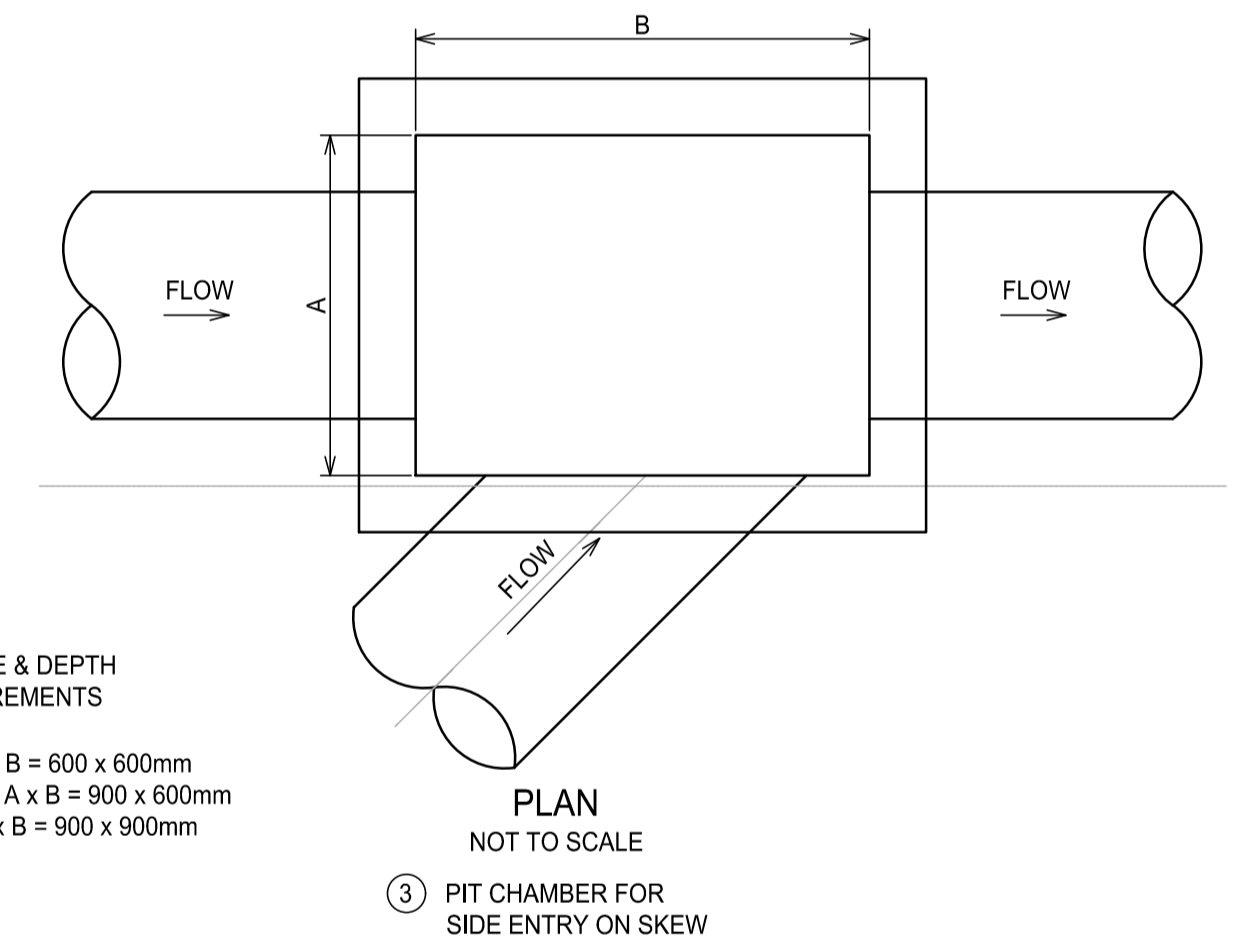

③ PIT CHAMBER FOR SIDE ENTRY ON SKEW

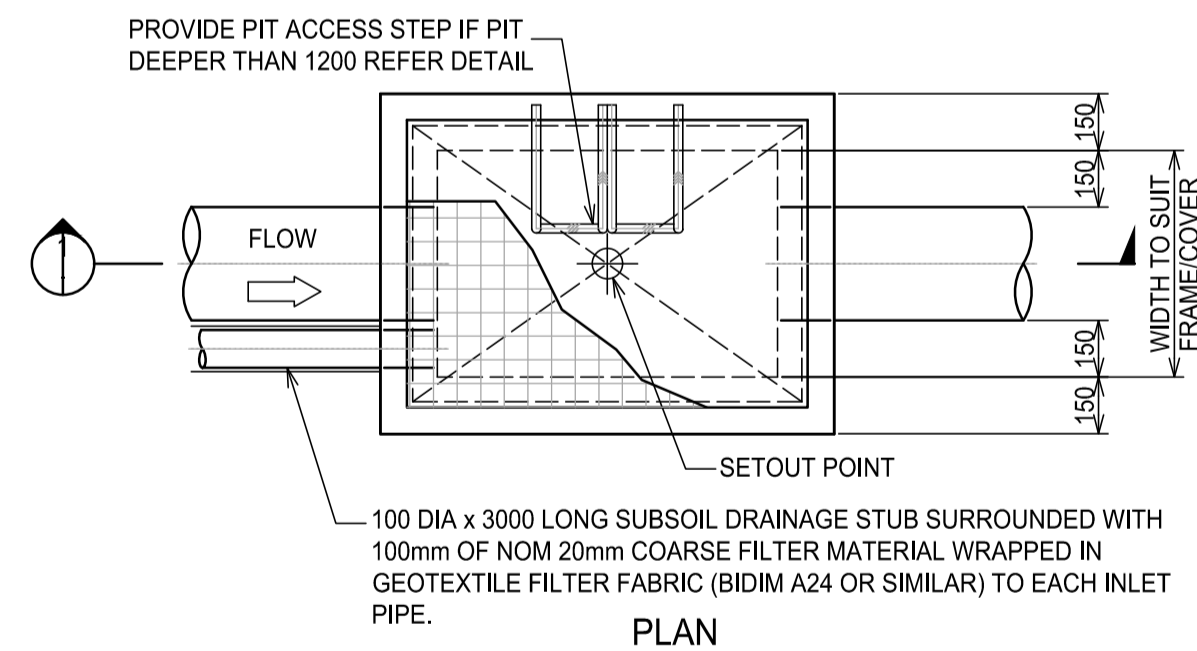

GRATED PIT DETAIL

SCALE 1:20

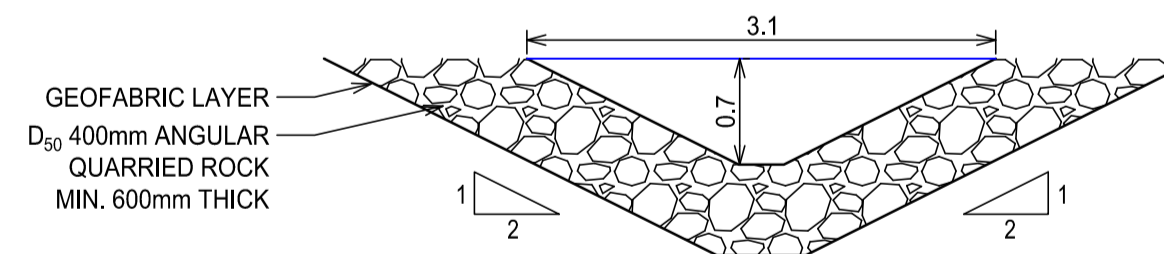

SWALE 1

SCALE 1:50

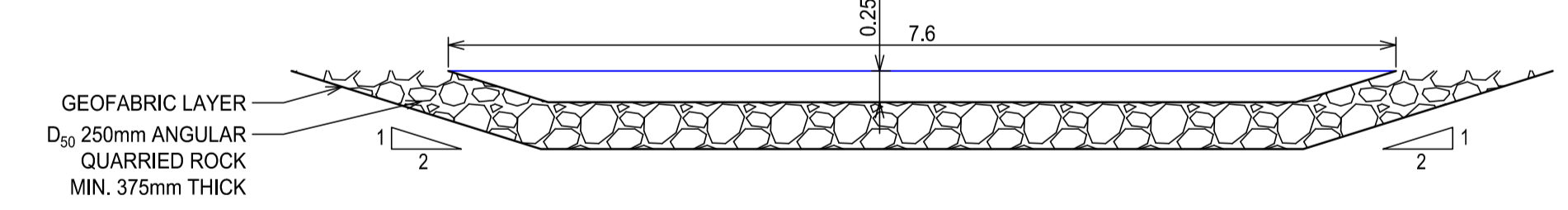

SWALE 2

SCALE 1:50

PRINTING NOTE:
THIS DRAWING TO BE PRINTED IN COLOUR.

A1 0 0.5 1.0 1.5 2.0 2.5 3.0 3.5 4.0 4.5 5.0 1:50 A1 0 0.5 1.0 1.5 2.0 1:20

Rev	Description	Eng	Draft	Date
1	ISSUE FOR DEVELOPMENT APPLICATION	AH	AH	TR 07.05.2025



T : 02 8810 5800 E : info@xavierknight.com.au
A : Level 7, 210 Clarence Street, Sydney NSW 2000
xavierknight.com.au
This drawing is copyright and is the property of XAVIER KNIGHT CONSULTING ENGINEERS Pty. Ltd. and must not be used without authorisation.

North	Project	Scale at A1	Drawn	Approved
	RESIDENTIAL DEVELOPMENT 24, 26 & 28 MIDDLE HARBOUR ROAD, LINDFIELD	AS SHOWN	AH	FC
	Sheet Subject	Job No	Drawing No	Revision
	STORMWATER DRAINAGE DETAILS - SHEET 1	250213	C09001	1

NOT TO BE USED FOR CONSTRUCTION

DEVELOPMENT APPLICATION

