



Macarthur Gardens North,
R3 Affordable Housing,
Goldsmith Ave, Macarthur NSW 2560
Residential Development

OPERATIONAL WASTE MANAGEMENT PLAN

28/07/2025
Report No. 6610
Revision C

Client

Landcom

<https://www.landcom.com.au/>

Architect

DKO

<https://dko.com.au/>

REVISION REFERENCE

Revision	Date	Prepared by	Reviewed by	Description
A	06/02/25	S. Dib	S. Lee	Draft
B	13/06/25	S. Lee	J. Parker	Draft
C	28/07/25	S. Lee	J. Parker	Final

The information contained in this document produced by Elephants Foot Consulting (EFC) is solely for the use of the client identified on the cover sheet for the purpose for which it has been prepared for. EFC undertakes no duty, nor accepts any responsibility for any third party who may rely upon this document. Reproduction, publication or distribution of this document without written permission from EFC is strictly prohibited.

TABLE OF CONTENTS

1.0	ACKNOWLEDGEMENT OF COUNTRY	3
2.0	EXECUTIVE SUMMARY	3
3.0	INTRODUCTION.....	3
3.1	SCOPE OF REPORT	4
3.2	SECRETARY’S ENVIRONMENTAL ASSESSMENT REQUIREMENTS (SEARS).....	4
3.3	REPORT CONDITIONS	5
4.0	LEGISLATION & GUIDANCE.....	6
5.0	DEVELOPMENT OVERVIEW.....	7
5.1	BACKGROUND.....	7
5.2	SITE LOCATION.....	8
6.0	RESIDENTIAL WASTE MANAGEMENT	9
6.1	RESIDENTIAL WASTE GENERATION ESTIMATES.....	9
6.2	RESIDENTIAL BIN SUMMARY	10
6.3	RESIDENTIAL CHUTE DISCHARGE EQUIPMENT SUMMARY	11
6.4	RESIDENTIAL WASTE DISPOSAL PROCEDURES.....	11
6.4.1	RESIDENTIAL GENERAL WASTE AND RECYCLING DISPOSAL PROCEDURES.....	11
6.4.2	RESIDENTIAL FOGO DISPOSAL PROCEDURES	12
6.5	RESIDENTIAL BIN COLLECTION PROCEDURES	12
6.6	OTHER RESIDENTIAL WASTE MANAGEMENT CONSIDERATIONS	13
6.6.1	RESIDENTIAL COMMON AREAS.....	13
6.6.2	LANDSCAPED AREAS AND GARDEN ORGANICS.....	13
6.6.3	RESIDENTIAL BULKY WASTE PROCEDURES.....	13
7.0	STAKEHOLDER ROLES & RESPONSIBILITIES	14
8.0	SOURCE SEPERATION	15
9.0	EDUCATION	16
9.1	SIGNAGE.....	16
10.0	POLLUTION PREVENTION.....	16
11.0	BIN WASHING.....	17
12.0	BIN MOVING PATHS.....	17
13.0	EQUIPMENT SUMMARY	18
14.0	WASTE ROOMS	19
15.0	CONSTRUCTION REQUIREMENTS.....	21
15.1	ADDITIONAL CONSIDERATIONS.....	21
16.0	CUMULATIVE IMPACTS	22
17.0	MITIGATION MEASURES.....	22
18.0	CONCLUSION	23
19.0	USEFUL CONTACTS.....	24

APPENDIX A:	ARCHITECTURAL PLANS.....	25
APPENDIX: A.1	BASEMENT FLOOR PLAN	26
APPENDIX: A.2	GROUND FLOOR PLAN	27
APPENDIX B:	INSTALLATION EQUIPMENT	28
APPENDIX: B.1	TYPICAL SINGLE CHUTE SHAFT & PENETRATION LAYOUT	29
APPENDIX: B.2	EXAMPLE RESIDENTIAL LEVEL RECYCLING BIN LAYOUT	30
APPENDIX: B.3	TYPICAL LINEAR TRACK SYSTEM FOR 1100L BINS	31
APPENDIX C:	PRIMARY WASTE MANAGEMENT PROVISIONS.....	33
APPENDIX: C.1	TYPICAL BIN SPECIFICATIONS.....	34
APPENDIX: C.2	SIGNAGE FOR WASTE AND RECYCLING BINS.....	35
APPENDIX: C.3	EXAMPLE COLLECTION VEHICLE INFORMATION.....	37
APPENDIX D:	SECONDARY WASTE MANAGEMENT PROVISIONS.....	39
APPENDIX: D.1	EXAMPLE HANDHELD BIN MOVERS	40
APPENDIX: D.2	EXAMPLE SEATED BIN MOVERS	41
APPENDIX: D.3	EXAMPLE BIN TRAILERS	42
APPENDIX: D.4	EXAMPLE BIN TOWING ATTACHMENTS	43
APPENDIX: D.5	EXAMPLE BIN LIFTER FOR 240L BINS.....	44
APPENDIX: D.6	EXAMPLE SOURCE SEPARATION RECEPTACLES	45

TABLE OF FIGURES

Figure 1: Masterplan Site	7
Figure 2: Site Location.....	8
.....	8

LIST OF TABLES

Table 1: Relevant SEARs	4
Table 2: Estimated General Waste, Recycling and FOGO Volumes	9
Table 3: Recycling Bins Per Level	10
Table 3: Chute Discharge Equipment Summary	11
Table 4: Stakeholder Roles and Responsibilities	14
Table 5: Operational Waste Streams.....	15
Table 6: Equipment Summary.....	18
Table 7: Waste Room Areas.....	19
Table 8: Waste Room Requirements	20
Table 10: Mitigation Measures	22

GLOSSARY OF ABBREVIATIONS AND TERMS

TERM	DESCRIPTION
<i>Bin-Carting Route</i>	Travel path for transporting bins from their allocated storage location to the nominated collection point
<i>Bin Lifter</i>	A device used to mechanically lift bins for the purpose of emptying them into larger bins and/or compactors.
<i>Bin Mover</i>	Either a handheld device (commonly referred to as a bin tug) or a ride-on device (typically a tractor or Class C vehicle with an attached bin trailer) used to facilitate the movement of bins across long distances or up ramps
<i>Bulky Waste</i>	Recycling items that are too large to be deposited into bins, including furniture, whitegoods, electronics and mattresses
<i>Collection Area/Point</i>	Designated area or point where bins are loaded onto the collection vehicle for servicing
<i>Communal Bin Room</i>	A central, shared bin room accessible to all residents or staff to dispose of their waste stream
<i>DA</i>	Development Application
<i>DCP</i>	Development Control Plan
<i>EPA</i>	Environment Protect Authority
<i>FOGO</i>	Food Organics and Garden Organics
<i>General Waste</i>	All non-recyclable and non-hazardous waste that is sent to landfill
<i>HRV</i>	Heavy Rigid Vehicle
<i>L</i>	Litre
<i>LEP</i>	Local Environmental Plan
<i>Mixed Use Development</i>	A development comprising a combination of both residential and commercial units or two or more different land uses within the one development.
<i>Mobile Bins</i>	Containers with a capacity up to and including 1100L designed to be collected by a rear-loading vehicle
<i>Multi-unit Residential Development</i>	Also known as MUD's, residential flat buildings, or apartment blocks, this is a residential development with multiple units that typically share facilities and services such as bins and collections.
<i>MRV</i>	Medium Rigid Vehicle
<i>Onsite Collection</i>	A collection arrangement whereby all bins are serviced by a collection vehicle within the property boundary, either in the building's basement or at grade and off-street.
<i>Owners Corporation</i>	An organisation or group of persons that is identified by a particular name and that acts, or may act, as an entity

<i>Recycling</i>	Waste stream that combines all recycling, including comingled recycling, paper/cardboard and metals.
<i>Source Separation Receptacles</i>	Communal containers used throughout the development for the day-to-day disposal of different waste streams
<i>SRV</i>	Small Rigid Vehicle
<i>Waste Stream</i>	A classification used to describe waste of a particular type (eg. food waste stream)
<i>WHS</i>	Workplace Health and Safety

1.0 ACKNOWLEDGEMENT OF COUNTRY

Elephants Foot Consulting (EFC) acknowledges that every project we work on takes place on First Peoples land. We recognise Aboriginal and Torres Strait Islander People as Traditional Custodians of this land. We pay respect to ancestors and Elders, past and present.

2.0 EXECUTIVE SUMMARY

This Operational Waste Management Plan has been prepared by Elephants Foot Consulting to accompany a State Significant Development Application (SSDA) for an affordable housing development within the Macarthur Gardens North precinct (MGN) in the Campbelltown Local Government Area (LGA). The MGN precinct is identified as Lot 1097 in DP1182558.

This report has been prepared to address the Secretary's Environmental Assessment Requirements (SEARs) issued for the project (SSD-80482713) on 6 March 2025.

This report concludes that the proposed development is suitable and warrants approval subject to the implementation of the following mitigation measures.

- Reduce waste generation at the source
- Recycle materials wherever possible
- Manage and dispose of all waste streams properly
- Collect and report waste management data

Following the implementation of the above mitigation measures, the remaining impacts are considered appropriate.

3.0 INTRODUCTION

Robust waste management strategies are required for new developments to support the design and sustainable performance of the building. It is EFC's belief that a successful waste management strategy contains three key objectives:

- Promote responsible source separation** to reduce the amount of waste that goes to landfill by implementing convenient and efficient waste management systems.
- Ensure adequate waste and recycling provisions and procedures** are established that will cater for potential changes during the operational phase of the development.
- Comply** with all relevant council codes, policies, and guidelines.

To achieve these objectives, this OWMP identifies and details the following components:

- Waste streams expected to be generated onsite and anticipated volumes;
- Suitable bin sizes and quantities;
- Waste and recycling disposal procedures;
- Bin room size estimations and equipment recommendations; and
- Waste collection strategies, locations and frequencies.

It is vital that this OWMP is integrated into the overall management of the building and is clearly communicated to all relevant stakeholders.

3.1 SCOPE OF REPORT

This OWMP only applies to the **operational** phase of the proposed development; therefore, the requirements outlined in this OWMP must be implemented during the operational phase of the site and may be subject to review upon further expansion of, and/or changes to the development.

The waste management of the **construction** and **demolition** phases of the development are not addressed in this report. A construction and demolition WMP will need to be provided separately.

3.2 SECRETARY'S ENVIRONMENTAL ASSESSMENT REQUIREMENTS (SEARS)

This report has been prepared in response to the requirements contained within the Secretary's Environmental Assessment Requirements (SEARs) dated 6 March 2025 and issued for the SSDA (SSD-80482713). Specifically, this report has been prepared to respond to the SEARs requirement issued below.

Table 1: Relevant SEARs

17. Waste Management	Relevant Section of Report
<i>Provide measures to be implemented to manage, reuse, recycle and safely dispose of waste in accordance with any council waste management requirements</i>	Section 5
<i>Identify appropriately sited waste storage areas, collection access paths/roads and appropriate servicing arrangements for the site.</i>	Section 5

3.3 REPORT CONDITIONS

The purpose of this report is to document an OWMP as part of a development application, which is supplied by EFC with the following limitations:

- Drawings, estimates and information contained in this OWMP have been prepared by analysing the information, plans and documents supplied by the client and third parties including Council and other government agencies. The assumptions based on the information contained in the OWMP is outside the control of EFC,
- The figures presented in the report are an estimate only – the actual amount of waste generated will be dependent on the occupancy rate of the building/s and waste generation intensity as well as the building management’s approach to educating residents and tenants regarding waste management operations and responsibilities,
- The building manager will adjust waste management operations as required based on actual waste volumes (e.g. if waste is greater than estimated) and increase the number of bins and collections accordingly,
- The report will not be used to determine or forecast operational costs or prepare any feasibility study or to document any safety or operational procedures,
- The report has been prepared with all due care; however no assurance is made that the OWMP reflects the actual outcome of the proposed waste facilities, services, and operations, and EFC will not be liable for plans or results that are not suitable for purpose due to incorrect or unsuitable information or otherwise,
- EFC offer no warranty or representation of accuracy or reliability of the OWMP unless specifically stated,
- Any manual handling equipment recommended in this OWMP should be provided at the recommendation of the appropriate equipment provider who will assess the correct equipment for supply,
- Design of waste management chute equipment and systems must be approved by the supplier,
- EFC cannot be held accountable for late changes to the design after the OWMP has been submitted to Council,
- EFC will provide specifications and recommendations on bin access and travel paths within the OWMP, however it is the architect’s responsibility to ensure the architectural drawings meet these provisions,
- EFC are not required to provide information on collection vehicle swept paths, head heights, internal manoeuvring or loading requirements. It is assumed this information will be provided by a traffic consultant,
- Council are subject to changing waste and recycling policies and requirements at their own discretion.
- This OWMP is only finalised once the draft watermark has been removed. If the draft watermark is present, the information in the OWMP is not confirmed.

4.0 LEGISLATION & GUIDANCE

Waste management and resource recovery regulation in Australia is administered by the Australian Constitution, Commonwealth laws, and international agreements. State and territory governments maintain primary responsibility for controlling development and regulating waste. The following legislation has been enacted in New South Wales, and provides the lawful underpinnings of this OWMP.

- NSW Environmental Planning & Assessment Act 1979
- NSW Protection of the Environment Operations Act 1997
- NSW Waste Avoidance & Resource Recovery Act 2001

At the local level, councils or Local Government Areas (LGAs) require OWMPs to be included in new development applications. This OWMP is specifically required by:

- Campbelltown Development Control Plan 2015
- Campbelltown Local Environmental Plan 2015

The primary purpose of a Development Control Plan (DCP) is to guide the planning process according to the aims of the corresponding local environmental plan (LEP). The DCP must be read in conjunction with the provisions of the relevant LEP.

Information provided in this OWMP comes from a wide range of waste management guidance at the local, state, and federal levels. The primary sources of guidance include:

- Campbelltown Development Control Plan 2015 – Part 5 Residential Flat Buildings and Mixed-Use Development
- NSW Better Practice Guide For Resource Recovery In Residential Developments 2019
- NSW Better Practice Guidelines for Waste Management and Recycling in Commercial and Industrial Facilities 2012
- NSW Waste Avoidance and Resource Recovery (WARR) Strategy 2014-2021
- NSW Waste Classification Guidelines 2014
- Australia's National Waste Policy 2018

5.0 DEVELOPMENT OVERVIEW

The SSDA seeks development consent for a 100% affordable housing development on site R3 of the MGN Precinct.

Specifically, the SSDA seeks development consent for:

- construction of two 3 to 9 storey residential flat buildings
- 130 dwellings, all of which are affordable housing
- one basement level for car parking
- landscaping
- communal open space area

The purpose of the project is to facilitate the delivery of high-quality affordable housing, on a strategically located site consistent with the vision for MGN.

All figures and calculations are based on area schedules as advised by our client and shown on architectural drawings.

5.1 BACKGROUND

On 14 December 2022, the Sydney Western City Planning Panel approved 3944/2021/DA-SW which comprised:

- a concept masterplan for mixed use development within MGN (see figure below)
- stage 1 works (parks, civil works, landscaping and subdivision of the site into superlots)

The masterplan sets the planning context for MGN. Importantly, the use and building envelopes for the site subject to this SSDA outlined in red below.

Figure 1: Masterplan Site

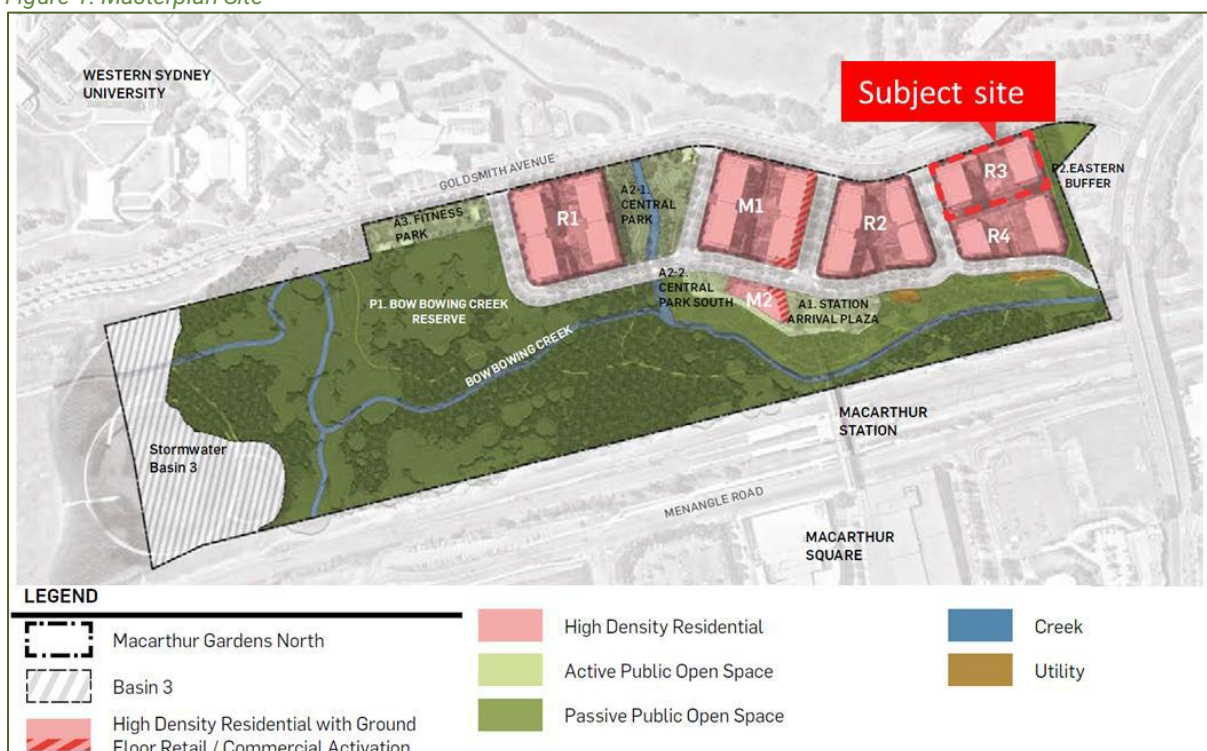

5.2 SITE LOCATION

The site is located in the MGN precinct within the Campbelltown LGA. The MGN Precinct is legally described as Lot 1097 in DP1182558.

As shown within the figure below, the site is within the north eastern corner of MGN and is rectangular in shape. The site has an area of 4,895m² and is currently bound by Goldsmith Avenue to the north, vacant land (known as site R4 within the 3944/2021/DASW concept masterplan) to the south and a pedestrian link and road, which are under construction, to the east and west respectively.

The site is zoned R4 High Density Residential pursuant to the Campbelltown Local Environmental Plan 2015 and is currently vacant land which has been excavated in accordance with Stage 1 of the 3944/2021/DA-SW approval.

Figure 2: Site Location



Source: Nearmaps

The site is also strategically located within the Glenfield to Macarthur Urban Renewal Corridor which is identified by the Department of Planning Housing and Infrastructure as a corridor to accelerate housing and jobs.

The vision on MGN is a mixed-use development precinct. Once developed, the site will be immediately bound by high density residential, roads and landscape buffers.

Outside of the MGN precinct, the broader site context is characterised by educational establishments to the north and northwest (Western Sydney University and TAFE), vacant undeveloped land to the west, Macarthur Train Station, railway lines, commercial premises (including Macarthur Square Shopping Centre) and low density residential to the south and a recreation area known as Gilchrist Oval to the east. The site is also located approximately 43 kilometres south west of the Sydney CBD, and 20km south west of Liverpool.

6.0 RESIDENTIAL WASTE MANAGEMENT

The following section outlines best practice waste management for the residential component of the development, including waste stream generation estimates and disposal and collection procedures.

6.1 RESIDENTIAL WASTE GENERATION ESTIMATES

The *Campbelltown Development Control Plan 2015* has been referenced to calculate the total number of general waste and recycling bins. The New South Wales State Government is requiring all local councils to introduce a FOGO (Foods Organics and Garden Organics) collection service to be implemented within the next 2-7 years. Therefore, the food waste stream will be included in the waste management planning detailed in this report. NSW EPA's *Better Practice Guide for Resource Recovery in Residential Developments 2019* has been referenced to calculate the total number of food waste bins required for the residential units.

Calculations are based on generic general waste, recycling and Food Organics and Garden Organics (FOGO) rates. Actual volumes of general waste, recycling and FOGO generated in operation may differ according to the residents' actual waste management practices.

The following tables show the estimated volume (L) of general waste, recycling and FOGO generated by the development.

Table 2: Estimated General Waste, Recycling and FOGO Volumes

Building/ Core	# Units	General Waste Generation Rate (L/unit/week)	Generated General Waste (L/week)	Recycling Generation Rate (L/unit/week)	Generated Recycling (L/week)	FOGO Waste Generation Rate (L/unit/week)	Generated FOGO Waste (L/week)
A	64	110	7040	48	3072	25	1600
B	66	110	7260	48	3168	25	1650
TOTAL	130		14300		6240		3250
Bins & Collections		General Waste Bin Size (L)	1100	Recycling Bin Size (L)	1100	FOGO Waste Bin Size (L)	240
		General Waste Collections per Week	1	Recycling Collections per Week	1	FOGO Waste Collections per Week	1
		Total General Waste Bins Required	14	Total Recycling Bins Required	6	Total FOGO Waste Bins Required	14
Bins per Building/ Core		Building/ Core	# Bins	Building/ Core	# Bins	Building/ Core	# Bins
		A	7	A	3	A	7
		B	7	B	3	B	7

Note: At the time of writing, Council do not have an active FOGO collection service. Provision for FOGO bins at this development have been included to account for a future FOGO collection service.

Table 3: Recycling Bins Per Level

Core	Level	Units	Recycling Generation Rate (L/unit/week)	Generated Recycling (L/week)	Recycling Bins per Week	Recycling Collection Per Week	Total Recycling Bins Required
Core A	Ground	8	48	384	2	1	2
	Level 1	10	48	480	2	1	2
	Level 2	10	48	480	2	1	2
	Level 3	7	48	336	2	1	2
	Level 4	7	48	336	2	1	2
	Level 5	7	48	336	2	1	2
	Level 6	5	48	240	1	1	1
	Level 7	5	48	240	1	1	1
	Level 8	5	48	240	1	1	1
Core B	Ground	10	48	480	2	1	2
	Level 1	10	48	480	2	1	2
	Level 2	10	48	480	2	1	2
	Level 3	7	48	336	2	1	2
	Level 4	7	48	336	2	1	2
	Level 5	7	48	336	2	1	2
	Level 6	5	48	240	1	1	1
	Level 7	5	48	240	1	1	1
	Level 8	5	48	240	1	1	1
TOTAL		130		6240	30		30

Note: This table shows that some levels will need the 240L recycling bin replaced twice per week. These 240L bins will be decanted in to larger 1100L recycling bins.

6.2 RESIDENTIAL BIN SUMMARY

Based on the estimated volumes of general waste, recycling and FOGO generated by the development, the recommended bin quantities and collection frequencies are as follows:

General Waste: 14 x 1100L bins collected **1 x weekly**

Recycling: 6 x 1100L bins collected **1 x weekly**

FOGO: 14 x 240L bins collected **1 x weekly**

During operation, it is the responsibility of the building manager to monitor the number of bins required for the residential component of the development. General waste, recycling and FOGO volumes may change according to residents' attitudes to waste disposal, building occupancy levels or the development's management. Any requirements for adjusting the capacity of the waste facilities may be achieved by changing the number of bins, the bin sizes or collection frequencies. Building management will be required to negotiate any changes to bins or collections with the collection service provider.

6.3 RESIDENTIAL CHUTE DISCHARGE EQUIPMENT SUMMARY

It is strongly recommended that the bins and equipment at the base of each chute allows for at least 2 days' worth of general waste generation. Based on the estimated general waste volumes generated by each building/core, the following equipment is recommended:

Table 4: Chute Discharge Equipment Summary

General Waste			
Tower	Generated General Waste (L/week)	# 1100L Bins Required for 2 days' Capacity	Recommended Chute Discharge Equipment
A	7040	1.83	2-Bin Linear System
B	7260	1.89	2-Bin Linear System

The above is a recommendation only and equivalent volume handling equipment may be used subject to equipment supplier's recommendation/review.

6.4 RESIDENTIAL WASTE DISPOSAL PROCEDURES

Each unit will be provided with a storage area capable of holding separate receptacles for general waste, recycling and FOGO. This is typically located within kitchen areas beneath the workbench. This space should be sized to accommodate 40L receptacles (minimum) to account for 2 days' worth of general waste and recycling and 20L for FOGO storage.

6.4.1 RESIDENTIAL GENERAL WASTE AND RECYCLING DISPOSAL PROCEDURES

Single general waste chutes will be installed in each core with access provided to all residents on each residential level. Separate 240L recycling bins will be provided in a compartment adjacent to the general waste chute for the storage of recycling.

Residents will be responsible for walking their general waste and recycling to their allocated disposal point and placing their general waste into the general waste chute and recycling into the 240L recycling bins. The 240L recycling bins will be taken down to the chute discharge rooms to be decanted into the larger 1100L recycling bins using a bin lifter, and returned to each level to resume operational use.

Residents will wrap or bag their general waste before placing in the chute. Bagged waste should not exceed 3kg in weight, or 35cm x 35cm x 35cm. Residents will be responsible for loosely placing their recycling into the 240L bins. Recycling should be clean and must not be bagged as soft plastics contaminate recycling.

The general waste will discharge from the chutes into 1100L bins on linear tracks in the Chute Discharge Rooms located in the basement. The building manager will monitor bin capacities under the general waste chutes and exchange full bins with empty bins on the track systems when required. Recycling bins on each level will also be monitored by the building caretaker and full bins will be exchanged with empty bins as required.

Full and spare bins will be kept in the Bin Holding Room.

Refer to Council guidance for the types of materials accepted in the general waste and recycling streams.

6.4.2 RESIDENTIAL FOGO DISPOSAL PROCEDURES

The majority of organics waste generated from multi-unit residential developments (MUD's) comprises of food waste as opposed to garden waste. As such, calculations and management recommendations provided in this report considers that FOGO bins will primarily comprise of food organics.

The residents of each unit will be provided with a kitchen caddy for the separation of FOGO. Food organics must be contained in accordance with Campbelltown Council's future FOGO collection service procedures (for example a compostable liner). Any clippings from residential units can also be disposed of with the FOGO.

Each core will be provided with a FOGO Bin Cupboard which contains 240L bins for FOGO. The residents will be responsible for walking their FOGO down to their respective FOGO Bin Cupboard and placing it into the bins.

Building management is responsible for ensuring that the FOGO Bin Cupboards and FOGO bins are washed down frequently to ensure that hygiene and odour is managed.

6.5 RESIDENTIAL BIN COLLECTION PROCEDURES

Council will be engaged to collect the residential general waste, recycling and FOGO in accordance with Council's collection schedule. This report assumes that general waste will be collected weekly, recycling fortnightly and FOGO weekly.

Prior to collections, the Building Manager/Caretaker will be responsible for transporting the bins from Chute Discharge Rooms to the allocated collection point located in the basement. The Building Manager/Caretaker is also responsible for ensuring that the bins are adequately arranged for an efficient collection.

It is the responsibility of the caretaker to ensure that the loading area is clear of any vehicles or obstructions prior to waste collection.

On the day of collection, a Council collection vehicle will enter the site from the proposed secondary street and park in the loading bay. The Building Manager/Caretaker will be responsible for ensuring that the collection staff have access to the collection point. The collection staff will exit the vehicle and collect the bins from the bin holding room and return the empty bins once serviced.

Upon completion of servicing, the collection vehicle will exit the site onto the proposed secondary street in a forward direction. The Building Manager/Caretaker is responsible for returning the bins to their operational location to resume use.

All access and clearances to the collection point must be able to accommodate Council's waste vehicle.

6.6 OTHER RESIDENTIAL WASTE MANAGEMENT CONSIDERATIONS

The following sections outline other waste management considerations for the residential components.

6.6.1 RESIDENTIAL COMMON AREAS

Residential common areas will be supplied with suitably branded source separation receptacles where considered appropriate. Receptacles should be placed in convenient locations which are accessible to all residents. The building manager will monitor the capacity of these receptacles and empty the contents into the central collection bins as required.

6.6.2 LANDSCAPED AREAS AND GARDEN ORGANICS

Garden organics generated from surrounding landscaped areas and indoor foliage typically consists of lawn clippings, cuttings, leaves and branches.

Garden organics generated from surrounding landscaped areas will be managed and removed from the site by the designated landscaping contractors as they carry out scheduled landscaping maintenance works.

Garden organics generated from within residential units will be managed by the residents and should be disposed of into the FOGO bins.

6.6.3 RESIDENTIAL BULKY WASTE PROCEDURES

An area will be made available for the storage of discarded residential bulky waste items (e.g. whitegoods, furniture, etc.). This room should be located within close proximity of the collection point and must have a minimum doorway width of 1.5m to facilitate the movement of large items in and out of the room.

Campbelltown Council requires the Bulky Waste Room to be within 10m of the loading area and at least 10m² per building. Based on this rate, the Bulky Waste Room required for this development is a minimum of 20m².

Residents will need to liaise with building management regarding the transportation of bulky items and the availability of the Bulky Waste Room. It is the caretaker's responsibility to arrange collection dates with Council and coordinate these times with the residents.

On the day of bulky waste collection, a Council collection vehicle will enter the site from the proposed secondary street and park in the loading bay. Collection staff will collect the bulky waste items from the Bulky Waste Room. Once bulky items have been loaded onto the vehicle, the collection vehicle will exit the site onto the proposed secondary street in a forward direction

7.0 STAKEHOLDER ROLES & RESPONSIBILITIES

The following table outlines the primary roles and responsibilities of the respective stakeholders:

Table 5: Stakeholder Roles and Responsibilities

Roles	Responsibilities
Strata, Body Corporate or Management	<ul style="list-style-type: none"> • Co-ordinate the waste strategy within the site. • Ensure all waste service providers submit monthly reports on all equipment movements and waste quantities/weights. • Organise internal waste audits/visual assessments on a regular basis. • Purchase any on-going waste management equipment or maintenance of equipment once building is operational; and • Manage any non-compliances/complaints reported through waste audits.
Building Manager or Waste Caretaker	<ul style="list-style-type: none"> • Co-ordinate general waste, recycling and FOGO collections • Clean and transport bins as required. • Organise replacement or maintenance requirements for bins. • Organise, maintain and clean bin storage areas. • Organise bulky waste collections when required. • Investigate and ensure prompt clean-up of illegally dumped waste materials. • Prevent storm water pollution by taking necessary precautions (secure bin rooms, prevent overfilling of bins). • Abide by all relevant WH&S legislation, regulations, and guidelines. • Provide staff/contractors with equipment manuals, training, health and safety procedures, risk assessments, and PPE to control hazards associated with all waste management. • Assess any manual handling risks and prepare a manual handling control plan for bin transfers. • Ensure site safety for residents, children, visitors, staff and contractors; and • Ensure effective signage, communication and education is provided to occupants, tenants, maintenance staff, and cleaning contractors.
Residents	<ul style="list-style-type: none"> • Dispose of all general waste, recycling and FOGO in the allocated bins provided. • Ensure adequate separation of general waste, recycling and FOGO; and • Comply with the provisions of Council and the OWMP.
Waste Collection Contractor	<ul style="list-style-type: none"> • Provide a reliable and appropriate bin collection service. • Provide feedback to building managers/residents regarding contamination of recyclables; and • Work with building managers to customise waste systems where possible.
Gardening/Landscaping Contractor	<ul style="list-style-type: none"> • Remove all garden organics generated during gardening maintenance activities for recycling at an offsite location.
Developer	<ul style="list-style-type: none"> • Purchase all equipment required to implement this OWMP prior to the occupation of the building to be provided to the Strata or Body Corporate.

8.0 SOURCE SEPERATION

Better practice waste management includes the avoidance, reuse, and recovery of unwanted items, which can be achieved through source separation. The table below outlines what is typically included in various waste streams and how they can be managed. Refer to your local council for a list of accepted materials. Planet Ark can be accessed online to find other facilities that recover unwanted items.

Table 6: Operational Waste Streams

Waste Stream	Description	Typical Destination	Waste Stream Management
General Waste	The remaining portion of the waste stream that is not recovered for re-use, processing, or recycling. May include soft plastics, food scraps, polystyrene, etc.	Landfill	General waste should be bagged before placing in chutes.
Recycling	A mixture of items that are commonly recycled usually segregated through a MRF. Typically include food and beverage containers (e.g. aluminium, glass, steel, hard plastics, cartons). Also included cardboard and paper products.	Resource Recovery Centre	Recycling must not be bagged, and instead should be placed loosely in the designated recycling bins. Cardboard should be flattened before placing in the designated recycling bin.
FOGO	FOGO consists of unwanted or uneaten kitchen scraps that are easily compostable/biodegradable (e.g. vegetable peels, fruit rinds, coffee grounds) and garden organics including lawn clippings, leaves, pruning's and branches.	Composting Facility	FOGO should be bagged in compostable liners when deposited into the chute/s or bins and will be collected by Council.
Garden Organics	Garden organics consists of unwanted organic materials that are easily biodegradable and/or compostable (e.g. lawn clippings, branches)	Resource Recovery Centre	Landscape Maintenance Contractors will remove the garden organics from site during scheduled maintenance.
Electronic Waste	Discarded e-waste, electronic components and materials such as computers, mobile phones, keyboards, etc.	Resource Recovery Centre	Building manager arranges collection for e-waste recycling as needed by residents.
Bulky Waste Items	Items that are too large to place into general rubbish collection. This includes disused and/or broken furniture, mattresses, white goods, etc.	Resource Recovery Centre or Landfill	Residents liaise with building manager to store in Bulky Goods Room. Building manager arranges with Council for removal.
Other	Other recyclable items that require special recovery may include ink cartridges, batteries, chemical waste, fluorescent tubes, etc.	Resource Recovery Facility	Building manager arranges collection by appropriate recycling services when required.

9.0 EDUCATION

Educational material encouraging correct separation of general waste, recycling and FOGO must be provided to each resident. This should include the correct disposal process for bulky waste such as old furniture, large discarded items, and other materials including electronic and chemical wastes. It is recommended that the building caretaker provide information in multiple languages to support correct behaviours, and to minimise the possibility of chute blockages and contamination in communal bins.

Education and communication must be provided consistently on a regular basis to encourage behaviour change and account for transient building personnel such as new residents, tenants, or cleaning staff. Information should include:

- Descriptions of items accepted in the general waste, recycling and FOGO streams (refer to Council guidance);
- How to dispose of bulky waste and any other items that are not general waste, recycling or FOGO (refer to Council guidance);
- Residents' obligations to health and safety as well as building management; and
- How to prevent cross contamination among waste streams.

9.1 SIGNAGE

Signage and education are essential components to support best practice waste management including resource recovery, source separation, and diversion of waste from landfill. Signage should include:

- Clear and correctly labelled bins,
- Instructions for separating and disposing of waste items. Different languages should be considered,
- Locations of, and directions to, the waste storage areas with directional signs, arrows, or lines,
- The identification of all hazards or potential dangers associated with the waste facilities, and
- Emergency contact information should there be issues with the waste systems or services in the building.

The building manager is responsible for waste room signage including safety signage. Appropriate signage must be prominently displayed on doors, walls and above all bins, clearly stating what type of waste or recyclables is to be placed in each bin. All signage should conform to the relevant Australian Standards.

10.0 POLLUTION PREVENTION

Building management shall be responsible for the following to minimise dispersion of site litter and prevent stormwater pollution to avoid impact to the environment and local amenity:

- Promoting adequate waste disposal into the bins
- Securing all bin rooms (whilst affording access to staff/contractors)
- Prevent overfilling of bins, keep all bin lids closed and bungs leak-free
- Taking action to prevent dumping or unauthorised use of waste areas
- Require collection contractor/s to clean up any spillage when clearing bins

11.0 BIN WASHING

The bins will be cleaned by the building manager periodically to ensure hygiene and minimise odour.

Bin washing can occur within the bin rooms, using the room clean down facilities (i.e tap connection and drain). Alternatively, a specialist bin washing contractor can be engaged to clean the bins to an agreed schedule. The specialist bin contractor would collect the bins from the bin holding area and clean the bins with their specialised vehicle.

12.0 BIN MOVING PATHS

The building manager is responsible for the transportation of bins from their designated operational locations to the collection area, returning them once emptied to resume operational use.

Any movement of bins should minimise manual handling where possible, as bins become heavy when full. The building manager must assess manual handling risks and provide any relevant documentation to key personal.

The routes along the bin moving path should;

- Allow for a continuous route that is wholly within the property boundary.
- Be free from obstruction and obstacles such as steps and kerbs.
- Be constructed of solid materials with a non-slip surface
- Be A minimum of 300mm wider than the largest bin used onsite.
- If bins are moved manually, the route must not exceed a grade of 1:14.
- If a bin moving device is used, the route cannot exceed the maximum operating grade of the device. This is typically a grade of 1:4, however this will vary depending on the model of bin moving device acquired for the site.

As the distance of the bin moving paths exceeds 10m, a bin moving device will be required to aid the movement of full bins. The developer is responsible for supplying all equipment required for moving bins this includes any bin lifters, bin moving devices and waste transfer bins. This equipment must be new and appropriate for the site. The developer should contact a bin-tug, trailer or tractor consultant to provide equipment recommendations.

Once the site is operational (and the developers is no longer involved) the building proprietors/strata will be responsible for maintaining, repairing and replacing waste management equipment.

13.0 EQUIPMENT SUMMARY

Table 7: Equipment Summary

	Part	Qty	Notes
Chutes	Please refer to supplier's information	1	(See APPENDIX: B.1 for Typical Single Chute Layout)
Chute Equipment	General Waste 2-bin 1100L bin Linear Track System	2	(See APPENDIX: B.3 for Typical Linear System)
Bin Mover	Suitable Bin Moving Device	1	(See APPENDIX: D.2 for Typical Bin Movers)
Bin Lifter	Suitable Bin Lifter	2	(See APPENDIX: D.5 APPENDIX: D.2 for Typical Bin Lifter)

14.0 WASTE ROOMS

The areas allocated for waste storage and collection areas are detailed in the table below and are estimates only.

The equipment recommended in the chute discharge rooms is to manage 2 days' worth of estimated general waste from that building core. Therefore, this represents the minimum equipment required in these rooms to satisfy best practice requirements. Additional bins or volume handling equipment can be included in these rooms to increase days of capacity or manual labour required in operation

Table 8: Waste Room Areas

Level	Waste Room Type	Equipment	Estimated Area Required (m ²)	Actual Area Provided (m ²)
Basement	Core A Chute Discharge Room	General Waste: 1 x 2-bin 1100L bin Linear Track System 1 x 1100L service bin 1 x 1100L recycling bin Bin Lifter	23	33
	Core A FOGO Bin Cupboard	FOGO: 2 x 240L bins	2	2
Basement	Core B Chute Discharge Room	General Waste: 1 x 2-bin 1100L bin Linear Track System 1 x 1100L service bin 1 x 1100L recycling bin Bin Lifter	23	30
	Core B FOGO Bin Cupboard	FOGO: 2 x 240L bins	2	2
Basement	Bin Holding Room/Collection Area	General Waste: 14 x 1100L bins Recycling: 6 x 1100L bins FOGO: 14 x 240L bins Bin mover and trailer for 4 x 240L bins	78	85
	Bulky Waste Room		20	21

EFC recommends bins sizes, collection frequencies and/or equipment for best practice waste management at this site, however EFC also acknowledges there are a range of other suitable options that may alter waste room requirements (e.g. floor area, accessibility, head height, etc.)

The waste room areas have been calculated based on equipment requirements and/or bin dimensions with an additional 70% of bin GFA factored in for manoeuvrability.

In addition, all doorways and passageways facilitating the movement of bins and/or bulky waste items must be at least 1500mm wide. The following table provides further waste room requirements.

Table 9: Waste Room Requirements

Waste Room Type	Waste Room Requirements
Chute Discharge Room	<ul style="list-style-type: none"> • Ceiling clearance height must be a minimum of 3000mm (subject to penetration location) • The chute penetration must have a minimum 500mm clearance of any service pipes or other overhead obstacles • All chute discharge points should be caged off to ensure the safety of any personnel accessing the waste room • 200mm clearance is required around compaction equipment • Where a chute offset is required, the angle of the offset must not exceed 30 degrees (subject to number of consecutive offset and/or up to 1500mm)
Residential Bin Holding Room and/or Bin Collection Area	<ul style="list-style-type: none"> • Bins must not be stacked in rows that are more than two bins deep.
Bulky Waste Room	<ul style="list-style-type: none"> • May be a dedicated room or screened area within another waste room • Must be in close proximity to the collection area • Area must also be allocated for the segregation of e-waste, gas bottles, cardboard, etc. • Doorway should be a minimum of 1500mm wide

15.0 CONSTRUCTION REQUIREMENTS

Waste room construction must comply with the minimum standards as outlined in the *Campbelltown Development Control Plan 2015*, in order to minimise odours, deter vermin, protect surrounding areas, and make it a user-friendly and safe area.

The *NSW Better practice guide for resource recovery in residential developments (2019)* also states that better practice bin storage areas should achieve more than the minimum compliance requirements, which are as follows:

- Ensuring BCA compliance, including ventilation. Where required, ventilation system must comply with AS1668.4-2012 The use of ventilation and air conditioning in buildings.
- Ensuring storage areas are well lit (sensor lighting preferred) and have lighting available 24 hours a day.
- Provision of bin washing facilities, including taps for hot and cold water provided through a centralised mixing valve. The taps must be protected from bins and be located where they can be easily accessed even when the area is at bin capacity.
- Floor constructed of concrete at least 75mm thick.
- Floor graded so that any water is directed to a sewer authority approved drainage connection to ensure washing bins and/or waste storage areas do not discharge flow into the stormwater drain.
- Provision of smooth, cleanable and durable floor and wall surfaces that extend up the wall to a height equivalent to any bins held in the area.
- Ensuring ceilings are finished with a smooth-faced non-absorbent material capable of being cleaned.
- All surfaces (walls, ceiling and floors) finished in a light colour.

15.1 ADDITIONAL CONSIDERATIONS

- Waste room floor to be sealed with a two-pack epoxy;
- All corners coved and sealed 1,200mm up, this is to eliminate build-up of dirt;
- Hot and cold water tap height and light switch height of 1.6m;
- Storm water access preventatives (grate);
- All walls painted with light colour and washable paint;
- Equipment electric outlets to be installed 1700mm above finished floor level;
- Optional automatic odour and pest control system installed
- If 660L or 1100L bins are utilised, 2 x 820mm (minimum) double-doors must be used;
- All personnel doors are hinged, lockable and self-closing;
- Conform to the Building Code of Australia, Australian standards and local laws; and
- Childproofing and public/operator safety shall be assessed and ensured
- Waste and recycling rooms must have their own exhaust ventilation system either;
 - Mechanically - exhausting at a rate of 5L/m² floor area, with a minimum rate of 100L/s minimum. Mechanical exhaust systems shall comply with AS1668.4.2012 and not cause any inconvenience, noise or odour problem; or
 - Naturally - permanent, unobstructed, and opening direct to the external air, not less than one-twentieth (1/20) of the floor area.

16.0 CUMULATIVE IMPACTS

A cumulative impact assessment has been undertaken to consider the potential interactions between the operational waste generation and other developments in the broader area. While cumulative impacts are typically relevant for shared environmental factors such as traffic and noise, their application to operational waste is limited due to the localised and self-contained nature of the waste management.

Waste from this development will be predominately managed by council. Based on available data, the waste infrastructure is not being subjected to cumulative pressure. The transportation of waste is relevant to traffic cumulative impacts rather than wastes. Waste from this project will not materially compound regional waste impacts or exceed landfill or recycling facility capacities. Therefore, the cumulative waste impact of this project is considered negligible.

17.0 MITIGATION MEASURES

Following the implementation of the above mitigation measures, any impacts will be acceptable and appropriate.

Table 10: Mitigation Measures

Project Stage	Mitigation Measure	Mitigation Measure – Actions Required	Reason for Mitigation Measure	Relevant Section of the Report
Site is Operational	Waste Reduction	Encourage practices that reduce waste generation at the source	Reducing waste at the source minimizes the volume of waste generated.	Section 9
	Safe Disposal Methods	Ensure proper management and disposal of all waste streams.	Effective waste management minimizes environmental contamination.	Sections 6-12
	Onsite operational waste management requirements	Management must ensure requirements outlined in this OWMP are implemented onsite.	Making sure all operational waste activities abide by requirements outlined in the report.	OWMP
	Monitoring & Reporting	Implement data collection and reporting systems for waste management activities.	Monitoring provides insights into waste generation patterns, helping identify areas for improvement and ensuring compliance with regulations.	Section 6
	Policy & Regulation Compliance	Regularly review and update waste management plans to comply with environmental regulations.	Compliance with regulations ensures that waste management practices are environmentally responsible.	Section 4

18.0 CONCLUSION

With the implementation of the mitigation measures outlined in this Operational WMP the residual impacts associated with operational waste are considered appropriate and acceptable. Waste will be managed in accordance with best practice guidelines, EPA regulations, and local council requirements, ensuring minimal landfill disposal and negligible cumulative impact.

19.0 USEFUL CONTACTS

EFC does not warrant or make representation for goods or services provided by suppliers.

LOCAL COUNCIL

Campbelltown City Council	Ph: (02) 4645 4000	E: council@campbelltown.nsw.gov.au
---------------------------	--------------------	---

PRIVATE WASTE COLLECTION PROVIDER

Capital City Waste Services	Ph: 02 9599 9999	E: service@ccws.net.au
Sydney Waste	Ph: 02 8661 0031	
Waste Clear	Ph: 1300 525 352	E: admin@wasteclear.com.au

BIN MOVING DEVICE SUPPLIERS

Elephants Foot Equipment	Ph: 1300 435 374	E: equipment@elephantsfoot.com.au
Sitecraft	Ph: 1300 363 152	E: sales@sitecraft.com.au

BALER SUPPLIERS

Elephants Foot Equipment	Ph: 1300 435 374	E: equipment@elephantsfoot.com.au
--------------------------	------------------	---

ORGANIC DIGESTERS AND DEHYDRATORS

Elephants Foot Equipment	Ph: 1300 435 374	E: equipment@elephantsfoot.com.au
Waste Master	Ph: 1800 614 272	E: hello@wastemasterpacific.com.au

COOKING OIL CONTAINERS AND DISPOSAL

Cookers	Ph: 1300 882 299	E: info@cookers.com.au
Auscol	Ph: 1800 629 476	E: sales@auscol.com

ODOUR CONTROL

Elephants Foot Equipment	Ph: 1300 435 374	E: equipment@elephantsfoot.com.au
--------------------------	------------------	---

SOURCE SPERATION BINS

Method Recycling	Ph: 0499 890 455
------------------	------------------

BINS AND BIN EQUIPMENT

Elephants Foot Equipment	Ph: 1300 435 374	E: equipment@elephantsfoot.com.au
SULO	Ph: 1300 364 388	E: sulosales@pactgroup.com

CHUTES, COMPACTORS AND EDIVERTER SYSTEMS

Elephants Foot Chute Solutions	Ph: 1300 435 374	E: chutes@elephantsfoot.com.au
--------------------------------	------------------	---

APPENDIX A: ARCHITECTURAL PLANS

APPENDIX: A.1 BASEMENT FLOOR PLAN

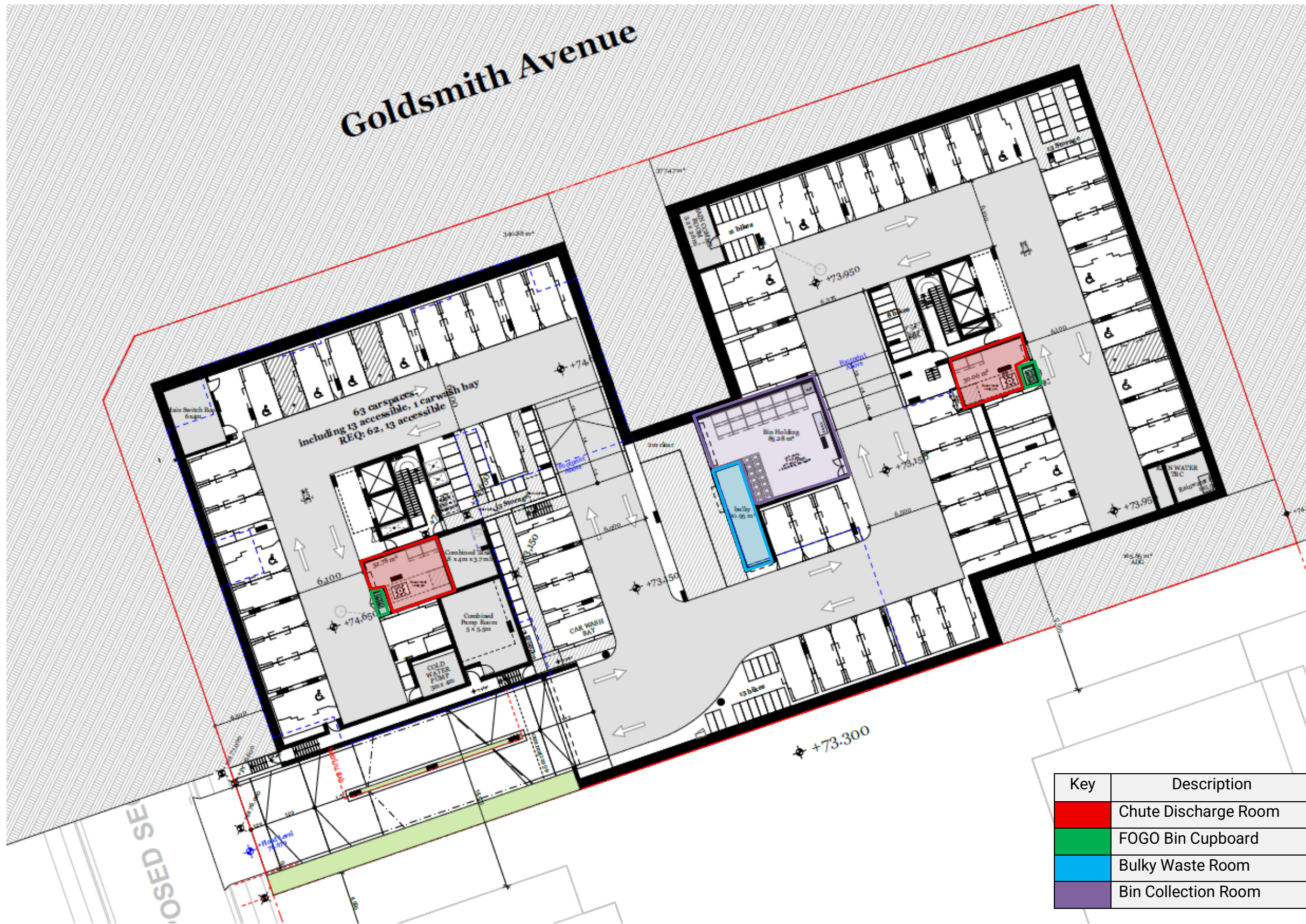

Source: DKO, DA200, Revision A – Basement Level 01

APPENDIX: A.2 GROUND FLOOR PLAN



Source: DKO, DA201, Revision A – Ground Floor

APPENDIX B: INSTALLATION EQUIPMENT

APPENDIX: B.1 TYPICAL SINGLE CHUTE SHAFT & PENETRATION LAYOUT



CHUTE SHAFT & PENETRATION SET-OUT
SINGLE Ø610 STEEL

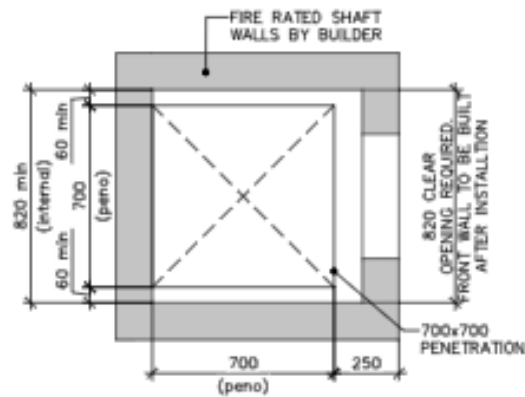

01 SINGLE (610Ø) GALV. STEEL CHUTE PENETRATION SET-OUT

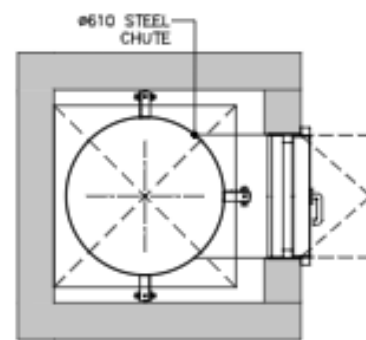

02 SINGLE (610Ø) GALV. STEEL CHUTE LAYOUT

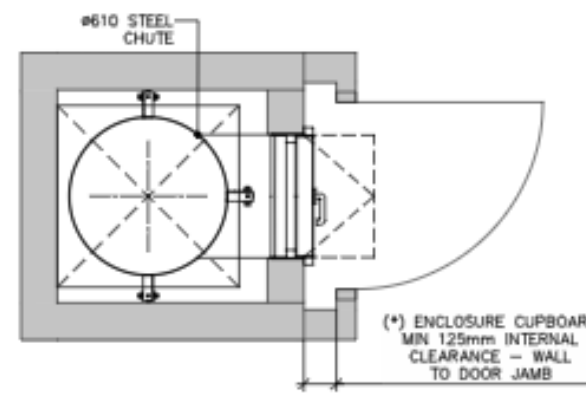

03 SINGLE (610Ø) GALV. STEEL CHUTE LAYOUT with ENCLOSURE CUPBOARD (*)

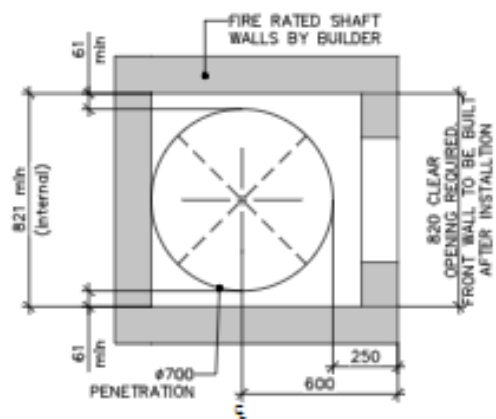

04 SINGLE (610Ø) GALV. STEEL CHUTE WITH CIRCULAR PENETRATION SET-OUT

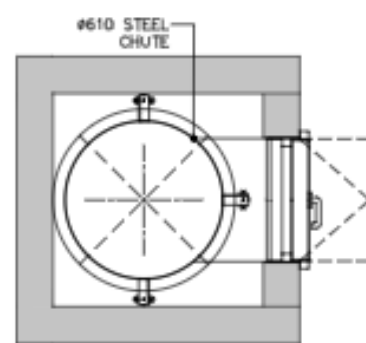

05 SINGLE (610Ø) GALV. STEEL CHUTE LAYOUT (WITH CIRCULAR PENETRATION)

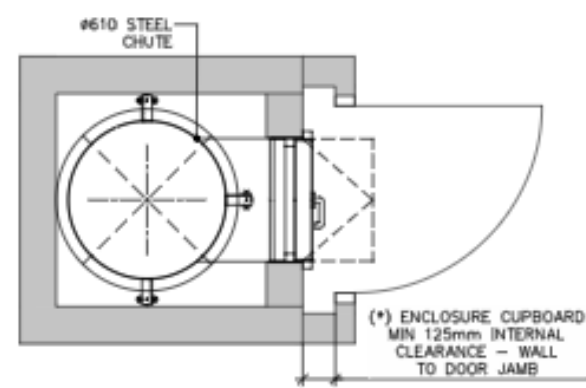

06 SINGLE (610Ø) GALV. STEEL CHUTE LAYOUT with ENCLOSURE CUPBOARD (*)

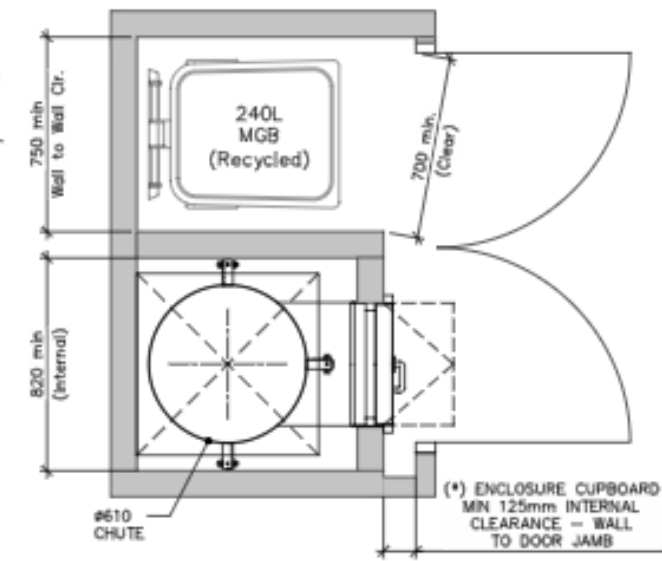

07 TYPICAL (610Ø) GALV. STEEL CHUTE LAYOUT with ENCLOSURE(*) & RECYCLING COMPARTMENT

(* NOTE: ENCLOSURES ARE RECOMMENDED IF THE CHUTE OPENS DIRECTLY TO A CORRIDOR OR IS NOT LOCATED IN A WASTE ROOM. IF CHUTE ACCESS IS WITHIN A WASTE ROOM THEN THE CUPBOARD ENCLOSURES ARE NOT REQUIRED.

SCALE 1:25 @ A3

Chute Shaft & Peno – Ver 1.2 April 26, 2022

Please Note: This is an example only – please refer to supplier's information and specification.

APPENDIX: B.2 EXAMPLE RESIDENTIAL LEVEL RECYCLING BIN LAYOUT

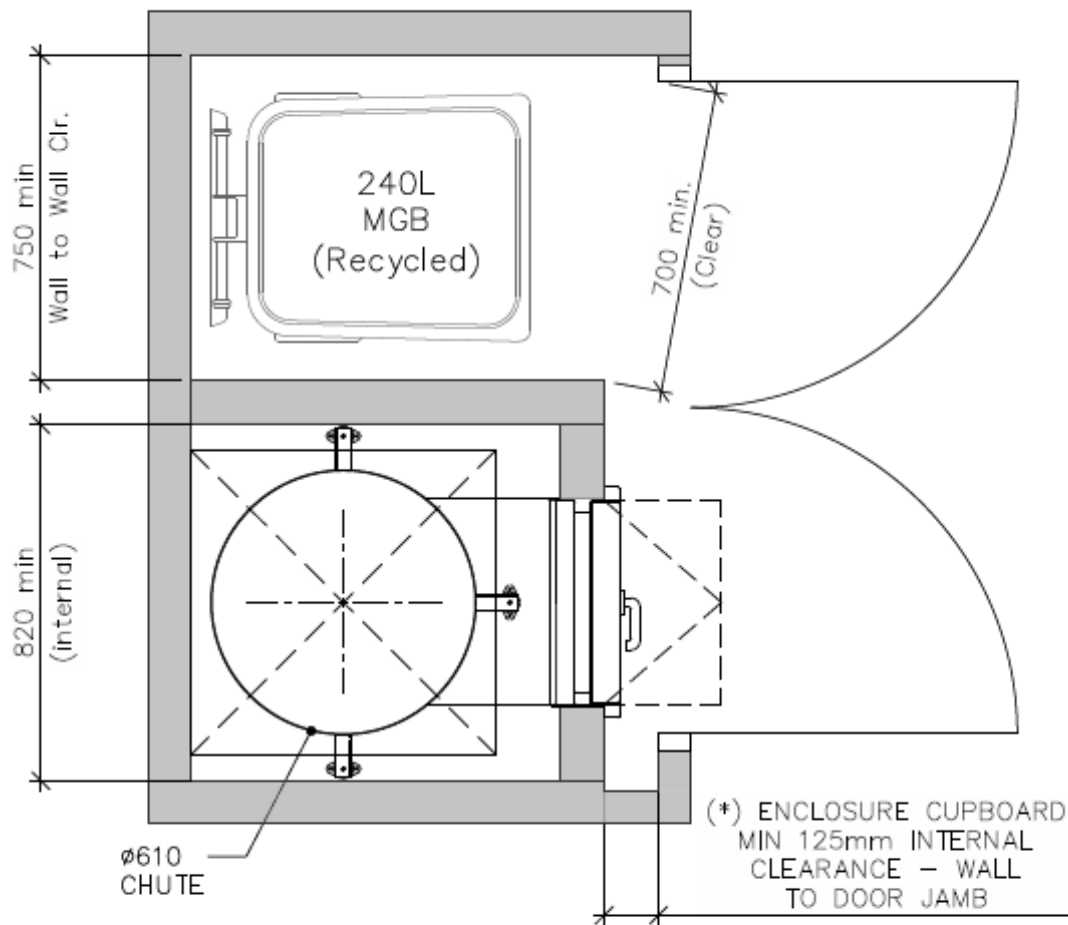

07 TYPICAL (610 ϕ) GALV. STEEL CHUTE LAYOUT with ENCLOSURE(*) & RECYCLING COMPARTMENT

Please Note: This is an example only – please refer to supplier’s information and specification

APPENDIX: B.3 TYPICAL LINEAR TRACK SYSTEM FOR 1100L BINS



1100 LITRE LINEAR TRACK SYSTEM

PRODUCT INFORMATION

Elephants Foot 1100 Litre bin Linear Track System is a versatile waste handling solution for many types of multi-storey or multi-level developments. The Linear Track System collects waste or recycling being disposed from the floors above through the chute system, discharging the material via a hopper that feeds the bins. Electromechanically driven with automated operation, the system utilises linear motion to automatically change over full bins. Once all the bins are filled, an indicator light will illuminate signifying that the bins are ready for withdrawal and collection. Available with or without compaction unit, our standard 660 litre bin Linear Track System is available in the standard 2 bin option. Our 3 Bin option is available as a special order.



SPECIFICATIONS

System Control	Electric PLC
Power Supply	415 V AC / 10A / 5 PIN
Motor Size (kW)	1.1
Maximum bin load	440 kg
Noise (dBA)	<85
Bin Size (L)	1100
Cycle time (sec)	60
Bin Quantity options	2 or 3

OPTIONAL EXTRAS

- Compaction unit – Please refer to the bin compactor product information sheet for details and specifications
- Enhanced safety add on's – Interlocking barriers, occupancy sensors or safety light curtains (presence sensing light barriers)
- Full bin SMS and email notification
- CMMS and BMS integration
- Extend warranty – Terms and conditions apply

STANDARD FEATURES & BENEFITS

- Simple operation with user friendly controls
- Increased waste servicing efficiency for the development.
- Automatic system control with manual override
- Robust unit construction for long performance life
- Low service and maintain costs
- Rotating flashing beacon (activated during operation)
- Quiet and efficient system operation
- Maximise safety for residents, caretakers and collectors
- Restrained design with minimal moving parts
- Can suit low ceiling clearances
- Floor contact components fully galvanised steel
- Retro fitting options to suit other chutes systems
- Compliant with relevant Building Codes and Standards
- Standard 12 month warranty

1,100 LITRE LINEAR TRACK SYSTEM



No. of Bins	Reference (mm)		
	A	B	C
2	900	3700	5300
3	2100	5940	7550

Available with or without compaction unit, our standard 1100 litre bin Linear Track System is available in the standard 2 bin option. Our 3 Bin option is available as a special order.

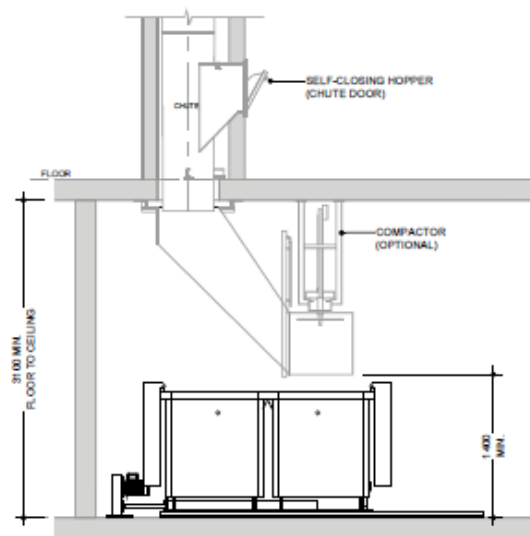
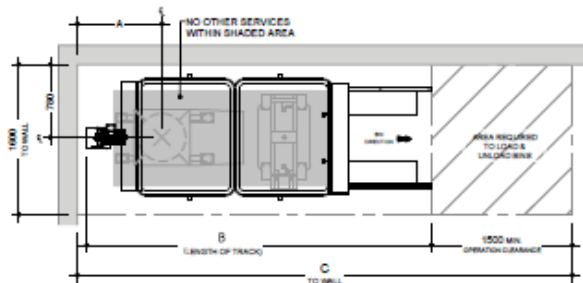

Notes:
Bins not provided by Elephants Foot

Drawings shown are for general information purposes only and provide minimum equipment spacial requirements for waste room design.

These drawings are not intended for site specific use or for construction. Each project is unique and will be designed to suit.

Additional equipment options, systems and configurations are available. For design assessment, information and advice, please contact an Elephants Foot design consultant on 1300 435 374

Please Note: This is an example only – please refer to supplier's information and specification

APPENDIX C: PRIMARY WASTE MANAGEMENT PROVISIONS

APPENDIX: C.1 TYPICAL BIN SPECIFICATIONS

Mobile bins

Mobile bins come in a variety of sizes and are designed for lifting and emptying by purpose-built equipment.

Mobile bins with capacities of up to 1700L must comply with *AS4123.6-2006 Mobile waste containers* which specifies standard sizes and sets out the colour designations for the bodies and lids of mobile waste containers indicating the type of materials they are used to collect.

The most common bin sizes are provided below, although not all sizes are shown. The dimensions are a guide only and differ slightly between manufacturers. Some bins have flat or domed lids and are used with different lifting devices. Refer to *AS4123.6-2006* for further details.

Table G1.1: Average dimension ranges for two-wheel mobile bins



Bin capacity	80L	120L	140L	240L	360L
Height (mm)	870	940	1065	1080	1100
Depth (mm)	530	530	540	735	820
Width (mm)	450	485	500	580	600
Approximate footprint (m ²)	0.24	0.26–0.33	0.27-0.33	0.41–0.43	0.49
Approximate weight (kg)	8.5	9.5	10.4	15.5	23
Approximate maximum load (kg)	32	48	56	96	Not known

Wheelie bin

Sources include Sulo, Single Waste, Cleanaway, SUEZ, just wheelie bins and Perth Waste for two-wheel mobile bins

Table G1.2: Average dimension ranges for four-wheel bulk bins



Bin capacity	660L	770L	1100L	1300L	1700L
Height (mm)	1250	1425	1470	1480	1470
Depth (mm)	850	1100	1245	1250	1250
Width (mm)	1370	1370	1370	1770	1770
Approx footprint (m ²)	0.86–1.16	1.51	1.33–1.74	2.21	2.21
Approx weight (kg)	45	Not known	65	Not known	Not known
Approx maximum load (kg)	310	Not known	440	Not known	Not known

Dome or flat lid container

Sources include Sulo, Signal Waste, Cleanaway, SUEZ, Just Wheelie Bins and Perth Waste

Source: *Better Practice Guide For Resource Recovery In Residential Developments 2019, NSW Environmental Protection Authority*

APPENDIX: C.2 SIGNAGE FOR WASTE AND RECYCLING BINS

Waste signs

Signs and educational materials perform several functions including:

- informing residents why it is important to recover resources and protect the environment
- providing clear instructions on how to use the bins and services provided
- alerting people to any dangers or hazards within the bin storage areas.

All waste, recycling and organic bins should be Australian Standard colours and clearly and correctly labelled, such as by a sticker on the lid and/or the body of the bin.

Communal bin storage areas should be clearly signposted with signs outlining how to correctly separate waste into the bins provided. The local council responsible for waste services may be a good source of signs and posters and can advise on what signs are suitable.

Information on who to contact to find out more about the recycling and/or other resource recovery services in the building should also be displayed in communal areas, such as on a noticeboard.

The Planet Ark website also has resources available free of charge for use by businesses and councils. These signs can be found at businessrecycling.com.au/research/signage.cfm

Figure I1.1: Examples of waste wall posters (EPA supplied)



Figure I1.2: Examples of bin lid stickers (EPA supplied)



Source: *Better Practice Guide For Resource Recovery In Residential Developments 2019*, NSW Environmental Protection Authority

Problem waste signs

The EPA has also produced a range of images and signs that can be used for problem wastes, such as fluoro globes and tubes, household and car batteries, e-waste and smoke detectors. To access these resources, contact the NSW EPA. Some examples are shown below.

Figure I2.1: Problem waste signs



Safety signs

The use of safety signs for waste resource recovery rooms must comply with *AS1319 Safety signs for occupational environments*. Safety signs must be used to regulate and control safety related to behaviour, warn of hazards and provide emergency information, including fire protection information. Suitable signs should be decided for each development as required.

Figure I3.1: Example safety signs



Source: *Better Practice Guide For Resource Recovery In Residential Developments 2019*, NSW Environmental Protection Authority

APPENDIX: C.3 EXAMPLE COLLECTION VEHICLE INFORMATION

General

Appropriate heavy rigid vehicle standards should be incorporated into the road and street designs in new developments where onsite collections are proposed. Road and street designs must comply with relevant Acts, regulations, guidelines, and codes administered by Austroads, Standards Australia, NSW Roads and Maritime Services, WorkSafe NSW and any local council traffic requirements.

Applicants and building designers should consult with councils and other relevant authorities before designing new roads or streets and access points for waste collection vehicles to establish specific design requirements.

Table H4.1: Australian Standards for turning circles for medium and heavy rigid class vehicles

Vehicle class	Overall length (m)	Design width (m)	Design turning radius (m)	Swept circle (m)	Clearance (travel) height (m)
Medium rigid vehicle	8.80	2.5	10.0	21.6	4.5
Heavy rigid vehicle	12.5	2.5	12.5	27.8	4.5

Source: *Better Practice Guide For Resource Recovery In Residential Developments 2019*, NSW Environmental Protection Authority

Large collection vehicles

Waste collection vehicles may be side-loading, rear-loading, front-lift-loading, hook or crane lift trucks. Vehicle dimensions vary by collection service, manufacturer, make and model. It is not possible to provide definitive dimensions, so architects and developers should consult with the local council and/or contractors.

The following characteristics represent typical collection vehicles and are provided for guidance only. Reference to *AS2890.2 Parking facilities: off-street commercial vehicle facilities* for detailed requirements, including vehicle dimensions, is recommended.

Table B2.1: Collection vehicle dimensions

Vehicle type	Rear-loading	Side-loading*	Front-lift-loading	Hook truck	Crane truck
Length overall (m)	10.5	9.6	11.8	10.0	10.0
Width overall (m)	2.5	2.5	2.5	3.0	2.5
Travel height (m)	3.9	3.6	4.8	4.7	3.8
Operational height for loading (m)	3.9	4.2	6.5	3.0	8.75
Vehicle tare weight (t)	13.1	11.8	16.7	13.0	13.0
Maximum payload (t)	10.0	10.8	11.0	14.5	9.5
Turning circle (m)	25.0	21.4	25.0	25.0	18

* The maximum reach of a side arm is 3 m.

Sources: JJ Richards, SUEZ, MacDonald Johnson, Cleanaway, Garwood, Ros Roca, Bingo and Edbro. Figures shown represent the maximum dimensions for each vehicle type.

Rear-loading collection vehicles

These vehicles are commonly used for domestic waste collections from MUDs and RFBs and sometimes for recycling. They can be used to collect waste stored in mobile bins or bulk bins, particularly where bins are not presented at the kerbside. They are also used for collecting bulky waste.

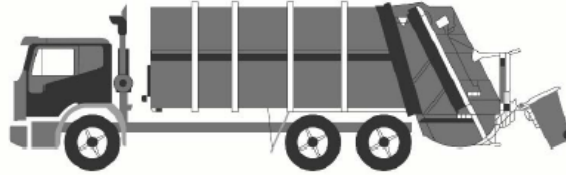

Rear-loading waste collection vehicle

Side-loading collection vehicles

This is the most commonly used vehicle for domestic waste, recycling and organics collections. It is only suitable for collecting mobile bins up to 360L in capacity.

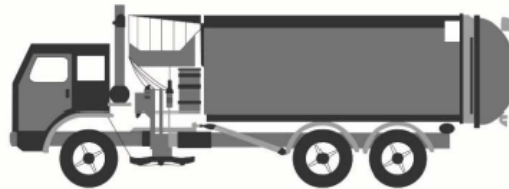

Side-loading waste collection vehicle

Front-lift-loading collection vehicles

These vehicles are commonly used for collecting commercial and industrial waste. They can only collect specially designed front-lift bulk bins and not mobile bins.



Front-lift-loading waste collection vehicle

Small collection vehicles

Typically, councils and their contractors operate with large collection vehicles (heavy rigid class vehicles) because they carry greater payloads and allow for more cost-effective collection services. Some councils, or their contractors, may have smaller collection vehicles in their fleet. Early discussion with the council is important to confirm this, but it should not be assumed that the council will have access to small collection vehicles.

The waste management systems and the location of the collection point should always be designed so that the council can provide the standard domestic waste service.

Source: *Better Practice Guide For Resource Recovery In Residential Developments 2019*, NSW Environmental Protection Authority

APPENDIX D: SECONDARY WASTE MANAGEMENT PROVISIONS

APPENDIX: D.1 EXAMPLE HANDHELD BIN MOVERS

moveXX
smart electric tugs

MOVEXX T2500
BIN MOVER BATTERY ELECTRIC

MoveXX T2500 Tow Tug is an extremely user friendly battery powered mobile towing unit that is ideal for applications where trolleys and rolling objects need to be moved from one place to another simply, efficiently and without physical effort. Some standard features included are: battery indicator, on board battery charger, battery, adjustable handle, dual speed and electric brake.

These units are fitted with an electromagnetic brake system for use on ramps and slopes

Features

- Electromagnetic brake for use on ramps and slopes
- Adjustable height handle



SPECIFICATION				
MODEL	DIMENSIONS (MM)	OPTIONS	PULL - PUSH CAPACITY (KG)	BATTERY
T2500-D	511 (w) x 757 (l)	* Centre mount 2x 240 lt. wheelie bin attachment	2500	AGM batteries 2x 85AH up to 8 hrs continuous operation
TOWING CAPACITY - ON FLAT GROUND (all models)			TOWING CAPACITY - SLOPE (all models)	
Towing up to 4x 660 lt. Wheelie Bin			Towing up to 2x 660 lt. Wheelie Bin Up / Down maximum 25% (1:4 slope)	
Towing up to 4x 1100 lt. Wheelie Bin			Towing up to 1x 1100 lt. Wheelie Bin Up / Down maximum 25% (1:4 slope)	
**Electromagnetic brake for use on ramps and slopes				



Please Note: This is an example only – please contact supplier for specific recommendations.

Source: Sitecraft - www.sitecraft.net.au

APPENDIX: D.2 EXAMPLE SEATED BIN MOVERS



MOTREC MT180

36V BATTERY ELECTRIC BIN MOVER

This hardworking tow device delivers outstanding performance. With its efficient motor and 4,500kg push-pull capacity. The MT180 is ideal for moving bin trailer also narrow enough to fit through most door openings. From its all-steel construction to its all-wheel braking, this tow tractor is built for years of heavy use in total comfort and safety. All this combined with superior AC technology makes short work of tough requests.

Features

- Front & rear brakes
- Pneumatic Tyres
- Comfortable ergonomic adjustable seat
- Complete with headlight, break lights, tailing lights & horn



SPECIFICATION

MODEL	DIMENSIONS (MM)	OPTIONAL EXTRAS	PULL - PUSH CAPACITY (KG)	BATTERY
MT180 36V	760 (w) x 2030 (l) x 1160 (h)	Flashing light on pole Conditional registration kit Cabin includes windscreen Weather Curtains	4500	48V TPPL battery pack, 157AH

TOWING CAPACITY - ON FLAT GROUND / SLOPE (all models) (all models)

Towing up to 5x 660 lt. Wheelie Bin Up / Down maximum 25% (1:4 slope)

Towing up to 4x 1100 lt. Wheelie Bin Up / Down maximum 25% (1:4 slope)



Please Note: This is an example only – please contact supplier for specific recommendations.

Source: Sitecraft - www.sitecraft.net.au

APPENDIX: D.3 EXAMPLE BIN TRAILERS



BIN TRAILER WITH ALUMINUM RAMP

Bin trailer suitable for moving 240lt, 660lt and 1,100lt bins including a 1200mm rear ramp complete with locking latches and gas strut assist. Height draw bar fitted with a jockey wheel large pneumatic tyres with precision bearing hubs



SPECIFICATION

MODEL	DIMENSION (MM)	SUITABLE FOR MOVING	PART NUMBERS	REAR RAMP DIMENSION (MM)
4x Bins Trailer	Internal - 1560 (l) x 1200 (w)	4x 240lt. Wheelie Bin	78811604	1200mm rear ramp complete with positive locking and gas strut assist
	External - 2300 (l) x 1500	2x 660lt. Wheelie Bin		
		1x 110lt. Wheelie Bin		
6x Bins Trailer	Internal - 2350 (l) x 1200 (w)	6x 240lt. Wheelie Bin	78811065	1200mm rear ramp complete with positive locking and gas strut assist
	External - 3100 (l) x 1500 (w)	3x 660lt. Wheelie Bin		
		2x 1100lt. Wheelie Bin		
8x Bins Trailer	Internal - 3200 (l) x 1200 (w)	8x 240lt. Wheelie Bin	78811066	1200mm rear ramp complete with positive locking and gas strut assist
	External - 3900 (l) x 1500 (w)	4x 660lt. Wheelie Bin		
		3x 1100lt. Wheelie Bin		
10x Bins Trailer	Internal - 3900 (l) x 1200 (w)	10x 240lt. Wheelie Bin	78811067	1200mm rear ramp complete with positive locking and gas strut assist
	External - 4600 (l) x 1500 (w)	5x 660lt. Wheelie Bin		
		4x 1100lt. Wheelie Bin		

OPTIONS

- Full registration
- Upgrade Includes : Lights | Wiring | Suspension | aaa Tyres | Compliance Plate

Please Note: This is an example only – please contact supplier for specific recommendations.

Source: Sitecraft - www.sitecraft.net.au

APPENDIX: D.4 EXAMPLE BIN TOWING ATTACHMENTS



UNIVERSAL BIN TOWING ATTACHMENTS

SUITE 660LT / 1100LT WHEELIE BINS

PARTS & FEATURES

Front Only - Part Number: 78811672

- Suit Sulo & Otto 600lt / 1100lt MGBs
- Spring loaded draw bar folds up
- No drilling of holes in the bin required
- Solidly fixed to the base of the bin using the castor mounting bolts
- Passivated zinc finish for long life
- Correct Rear Fixed or Directional Lock castors should be used

Rear Only - Part Number: 78811673

- Suit Sulo & Otto 600lt / 1100lt MGBs
- No drilling of holes in the bin required
- Solidly fixed to the base of the bin using the castor mounting bolts
- Passivated zinc finish for long life
- Correct Rear Fixed or Directional Lock castors should be used

For Steel Bin Front Only - Part Number: 78811781

- Suit Sulo & Otto 600lt / 1100lt MGBs
- No drilling of holes in the bin required
- Solidly fixed to the base of the bin using the castor mounting bolts
- Passivated zinc finish for long life
- Correct Rear Fixed or Directional Lock castors should be used

Direction Lock : 53191001

- Suit Sulo & Otto 600lt / 1100lt MGBs
- No drilling of holes in the bin required
- Solidly fixed to the base of the bin using the castor mounting bolts
- Passivated zinc finish for long life
- Correct Rear Fixed or Directional Lock castors should be used



Please Note: This is an example only – please contact supplier for specific recommendations.

Source: Sitecraft - www.sitecraft.net.au

APPENDIX: D.5 EXAMPLE BIN LIFTER FOR 240L BINS

versatip

Versatip Bin Tipper – 1500mm Tip



Specifications

Product Code	69121009
Product Name	1500mm Tip – Battery Powered
Capacity (kg)	250
Height (mm)	2085
Length (mm)	1330
Power Source	Battery Powered
Tipping Height (mm)	1500
Width (mm)	990

Please Note: This is an example only – please contact supplier for specific recommendations.

Source: Elephants Foot Equipment - www.elephantsfoot.com.au/equipment/

APPENDIX: D.6 EXAMPLE SOURCE SEPARATION RECEPTACLES

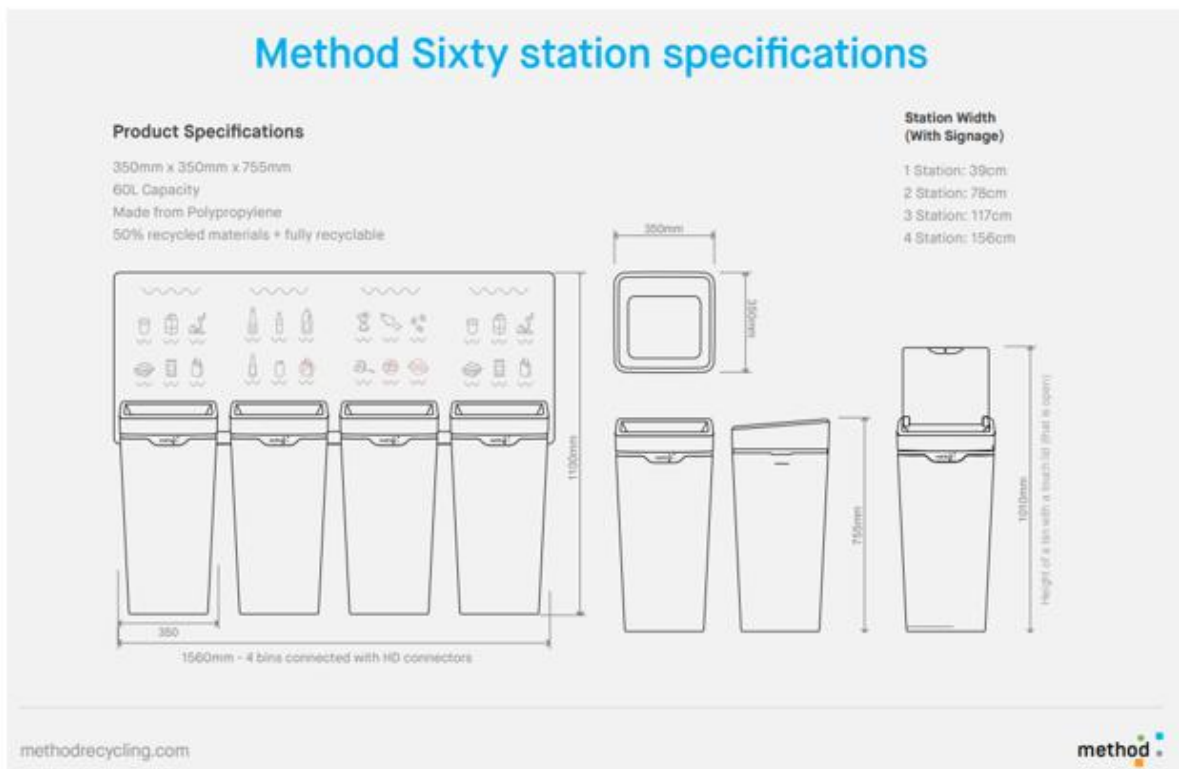
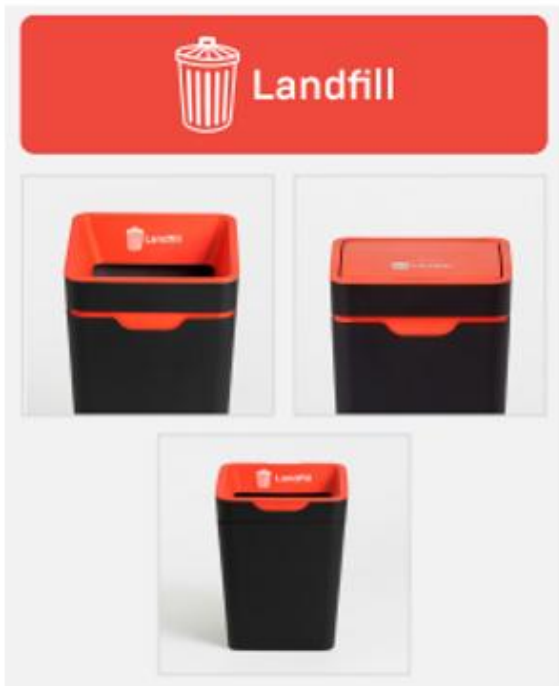

Source: Method Recycling - www.methodrecycling.com