

**NOTE:**  
 BOUNDARIES HAVE BEEN DETERMINED BY SURVEY ON 22/03/2017.  
 PRIOR TO ANY CONSTRUCTION WORK, SURVEY MARKS SHOULD BE PLACED TO DEFINE THE PROPERTY BOUNDARIES.  
 SERVICES SHOWN ARE INDICATIVE ONLY. POSITIONS ARE BASED ON SURFACE INDICATOR(S) LOCATED DURING FIELD SURVEY. CONFIRMATION OF THE EXACT POSITION SHOULD BE MADE PRIOR TO ANY EXCAVATION WORK. OTHER SERVICES MAY EXIST WHICH ARE NOT SHOWN.  
 LEVELS ARE BASED ON AUSTRALIAN HEIGHT DATUM (AHD) USING SSM 15774 WITH RL 52.762 (AHD).  
 RIDGE & GUTTER HEIGHTS HAVE BEEN OBTAINED BY INDIRECT METHOD AND ARE ACCURATE TO ± 0.05m.  
 CONTOURS SHOWN DEPICT THE TOPOGRAPHY. EXCEPT AT SPOT LEVELS SHOWN THEY DO NOT REPRESENT THE EXACT LEVEL AT ANY PARTICULAR POINT. THE SPOT LEVELS ARE TRUE FOR THEIR POSITION, AND ARE INTENDED TO BE USEFUL TO REPRESENT THE GENERAL TERRAIN. CARE SHOULD BE TAKEN IF EXTRAPOLATING.  
 JUNE 2022  
 SURVEY ADJUSTED TO MGA GDA2020 COORDINATES.  
 ORIGIN: PMS74624  
 CLASS: B  
 ORIENTATION: SSM 15774

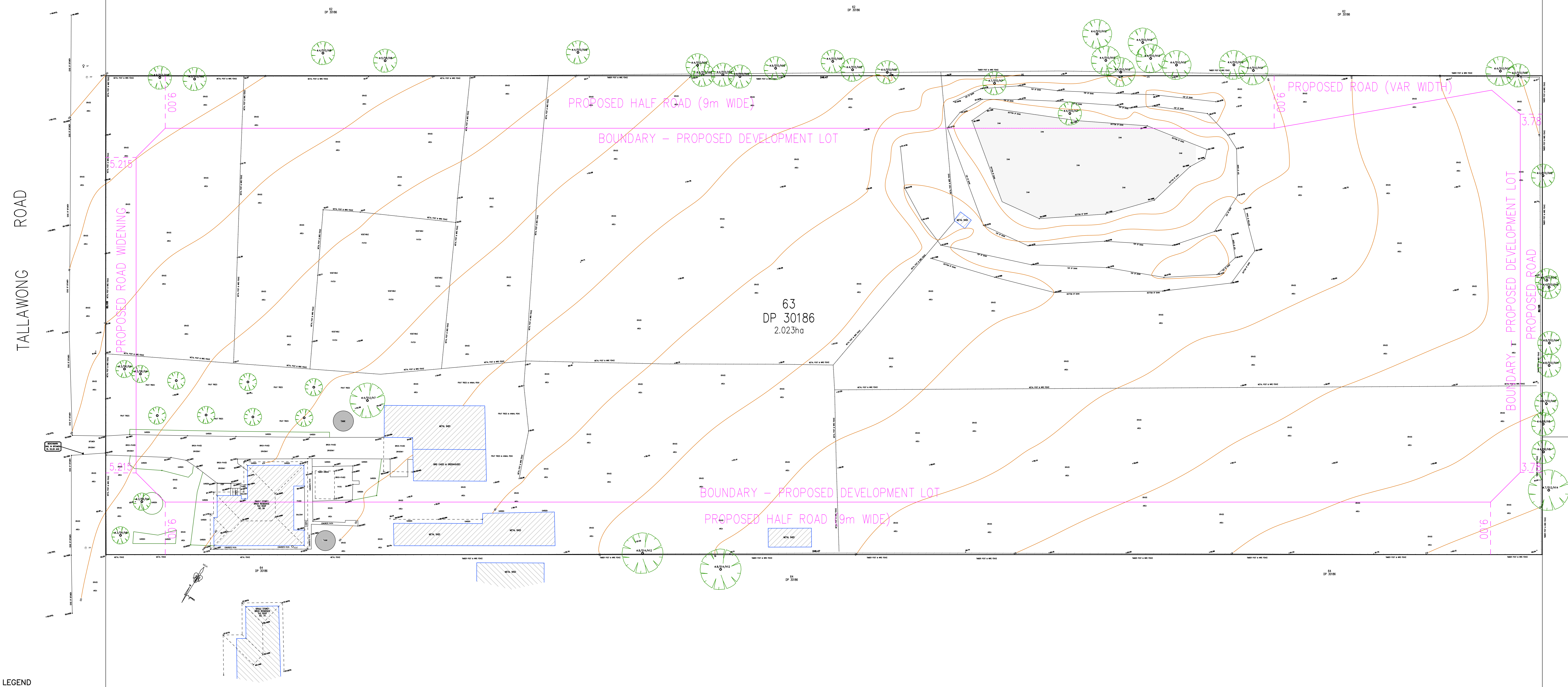
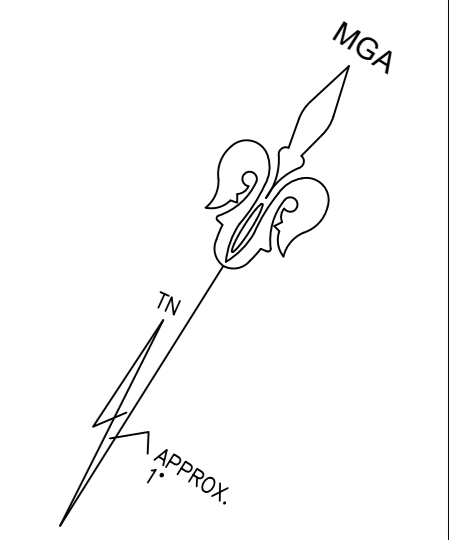

**LEGEND**

BENCH MARK	▲
TELSTRA PIT	⊠ TEL
ELECTRIC LIGHT POLE	⊠ LP
POWER POLE	⊠ PP
SIGN POST	⊠ SP
SEWER INSPECTION PIT	⊠ SIP
SEWER VENT	⊠ SEWER
MANHOLE	⊠ MH
SEWER MANHOLE	⊠ SMH
STOP VALVE	⊠ SV
WATER HYDRANT	⊠ HYD
WATER METER	⊠ WM
GAS METER	⊠ G
STATE SURVEY MARK	⊠ SSM

**TSS TOTAL SURVEYING SOLUTIONS**  
 ARTARMON | CAMDEN | MANLY VALE

**NOTE:**  
 INFORMATION CONTAINED IN THIS PLAN IS THE COPYRIGHT OF TOTAL SURVEYING SOLUTIONS. THE USE OR DUPLICATION WITHOUT THE WRITTEN CONSENT OF TOTAL SURVEYING SOLUTIONS CONSTITUTES AN INFRINGEMENT OF COPYRIGHT.

REVISION No.	REVISION DATE:	COMMENT:
C	26/6/2025	SURVEY MODEL MOVED TO MGA GDA2020 COORDINATES
D	25/8/2025	PROPOSED DEVELOPMENT IMPORTED FROM REVIT MODEL
E	29/8/2025	PROPOSED ROAD DEDICATION WIDTHS ADDED

**LEGEND:**

EC - EDGE OF CONCRETE	TB - TOP OF BANK
EB - EDGE OF BITUMEN	BB - BOTTOM OF BANK
TG - TOP OF GUTTER	AWN - AWNING
RR - ROOF RIDGE	
FL - FLOOR LEVEL	
Ø.4/S10/H16 - DIAMETER/SPREAD/HEIGHT	

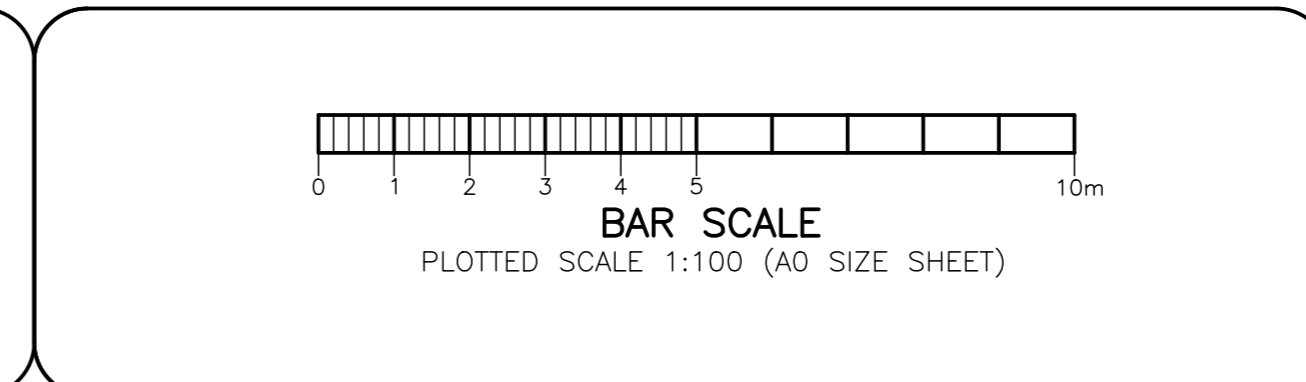

**PLAN SHOWING DETAIL & LEVELS**  
**OVER LOT 63 IN DP 30186**

CLIENT: LK GROUP - LKPG SPV 6 PTY LTD  
 PROJECT: ROUSE HILL  
 ADDRESS: 84 TALLAWONG ROAD, ROUSE HILL

JOB No.: 170515 (250462)	LGA: BLACKTOWN
PLAN No.: 170515 REV E	DATUM: AHD
DATE: 11/8/2017	SCALE: 1:250@A0
DRAWN: SF	CONT. INTERVAL: 0.25m
CHK: GS	COVER SHEET

Geoff Gallen  
 Registered Surveyor  
 No. 1063

**NOTE:**

BOUNDARIES HAVE BEEN DETERMINED BY SURVEY ON 22/03/2017.  
 PRIOR TO ANY CONSTRUCTION WORK, SURVEY MARKS SHOULD BE PLACED TO DEFINE THE PROPERTY BOUNDARIES.  
 SERVICES SHOWN ARE INDICATIVE ONLY. POSITIONS ARE BASED ON SURFACE INDICATOR(S) LOCATED DURING FIELD SURVEY. CONFIRMATION OF THE EXACT POSITION SHOULD BE MADE PRIOR TO ANY EXCAVATION WORK. OTHER SERVICES MAY EXIST WHICH ARE NOT SHOWN.  
 LEVELS ARE BASED ON AUSTRALIAN HEIGHT DATUM (AHD) USING SSM 15774 WITH RL 52.762 (AHD).  
 RIDGE & GUTTER HEIGHTS HAVE BEEN OBTAINED BY INDIRECT METHOD AND ARE ACCURATE TO ± 0.05m.  
 CONTOURS SHOWN DEPICT THE TOPOGRAPHY. EXCEPT AT SPOT LEVELS SHOWN THEY DO NOT REPRESENT THE EXACT LEVEL AT ANY PARTICULAR POINT. THE SPOT LEVELS ARE TRUE FOR THEIR POSITION, AND ARE INTENDED TO BE USEFUL TO REPRESENT THE GENERAL TERRAIN. CARE SHOULD BE TAKEN IF EXTRAPOLATING.  
 JUNE 2025  
 SURVEY ADJUSTED TO MGA GDA2020 COORDINATES.  
 ORIGIN: PMS74624  
 CLASS: B  
 ORIENTATION: SSM 15774

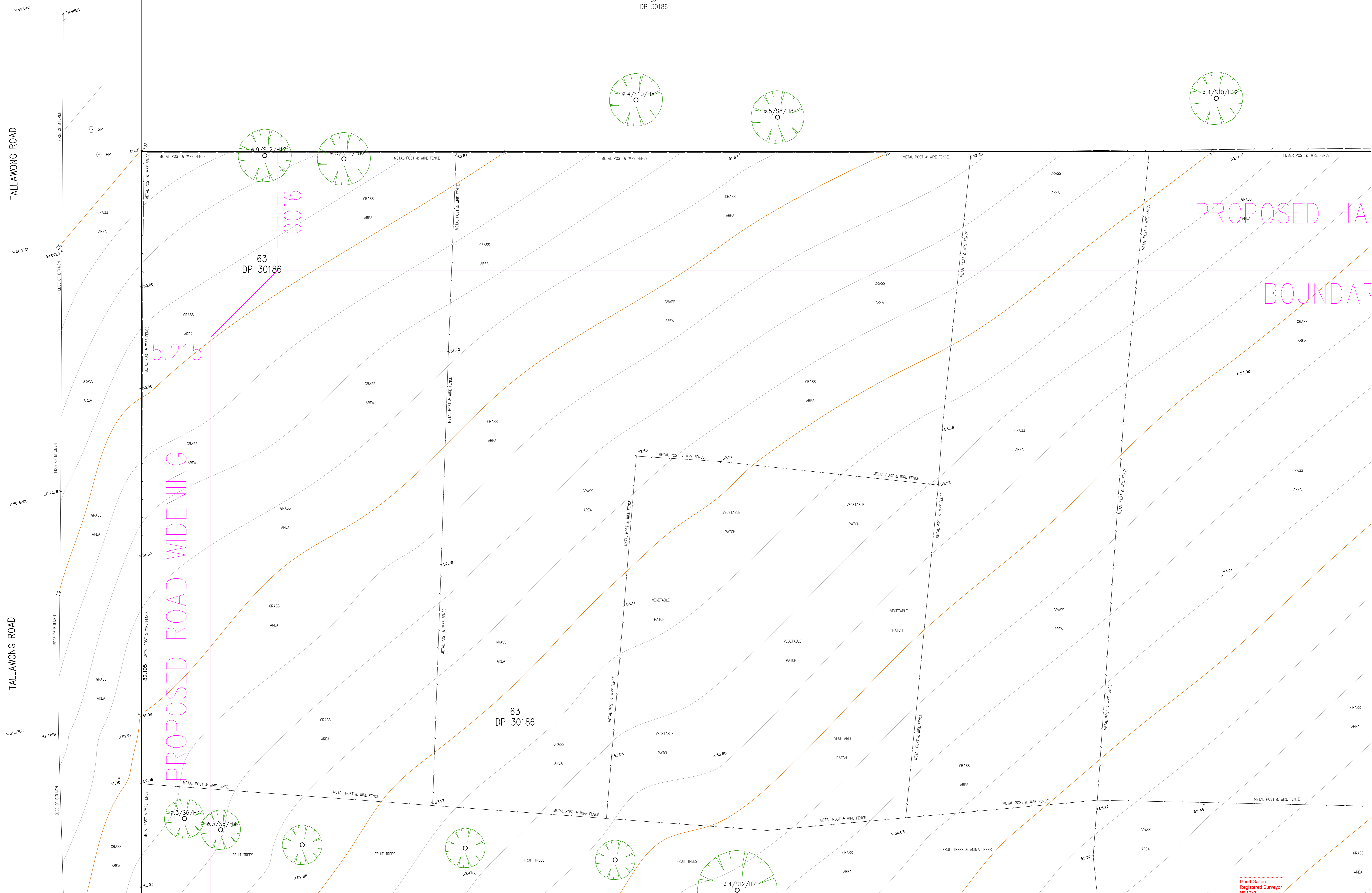
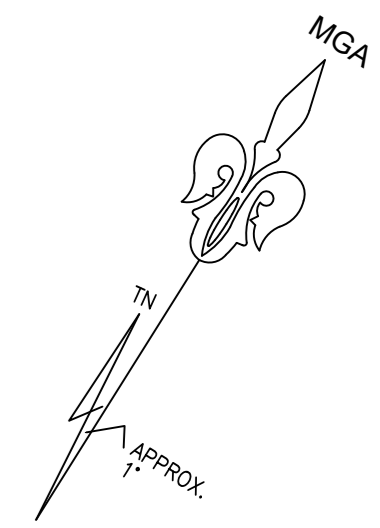

**LEGEND**

BENCH MARK	▲
TELSTRA PIT	⊠ TEL
ELECTRIC LIGHT POLE	⊠ LP
POWER POLE	⊠ PP
SIGN POST	⊠ SP
SEWER INSPECTION PIT	⊠ SIP
SEWER VENT	⊠ SEWER
MANHOLE	⊠ MH
SEWER MANHOLE	⊠ SMH
STOP VALVE	⊠ SV
WATER HYDRANT	⊠ HYD
WATER METER	⊠ WM
GAS METER	⊠ G
STATE SURVEY MARK	⊠ SSM

**TSS TOTAL SURVEYING SOLUTIONS**  
 ARTARMON | CAMDEN | MANLY VALE

**NOTE:**  
 INFORMATION CONTAINED IN THIS PLAN IS THE COPYRIGHT OF TOTAL SURVEYING SOLUTIONS. THE USE OR DUPLICATION WITHOUT THE WRITTEN CONSENT OF TOTAL SURVEYING SOLUTIONS CONSTITUTES AN INFRINGEMENT OF COPYRIGHT.

REVISION No.	REVISION DATE:	COMMENT:
C	26/6/2025	SURVEY MODEL MOVED TO MGA GDA2020 COORDINATES
D	25/8/2025	PROPOSED DEVELOPMENT IMPORTED FROM REVIT MODEL
E	29/8/2025	PROPOSED ROAD DEDICATION WIDTHS ADDED

**LEGEND:**

EC - EDGE OF CONCRETE	TB - TOP OF BANK
EB - EDGE OF BITUMEN	BB - BOTTOM OF BANK
TG - TOP OF GUTTER	AWN - AWNING
RR - ROOF RIDGE	
FL - FLOOR LEVEL	
Ø.4/S10/H16 - DIAMETER/SPREAD/HEIGHT	

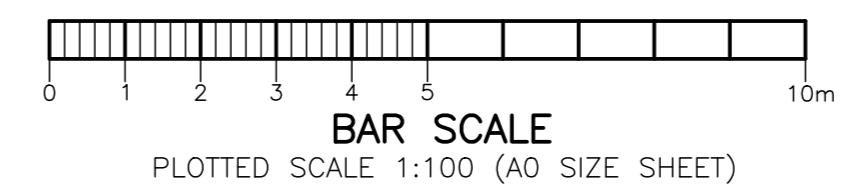

**PLAN SHOWING DETAIL & LEVELS**  
 OVER LOT 63 IN DP 30186

CLIENT: LK GROUP - LKPG SPV 6 PTY LTD  
 PROJECT: ROUSE HILL  
 ADDRESS: 84 TALLAWONG ROAD, ROUSE HILL

JOB No.: 170515 (250462)	LGA: BLACKTOWN
PLAN No.: 170515 REV E	DATUM: AHD
DATE: 11/8/2017	SCALE: 1:250@A0
DRAWN: SF	CONT. INTERVAL: 0.25m
CHK: GS	SHEET 1 OF 6

Geoff Gallen  
 Registered Surveyor  
 No. 1065

**NOTE:**  
 BOUNDARIES HAVE BEEN DETERMINED BY SURVEY ON 22/03/2017.  
 PRIOR TO ANY CONSTRUCTION WORK, SURVEY MARKS SHOULD BE PLACED TO DEFINE THE PROPERTY BOUNDARIES.  
 SERVICES SHOWN ARE INDICATIVE ONLY. POSITIONS ARE BASED ON SURFACE INDICATOR(S) LOCATED DURING FIELD SURVEY. CONFIRMATION OF THE EXACT POSITION SHOULD BE MADE PRIOR TO ANY EXCAVATION WORK. OTHER SERVICES MAY EXIST WHICH ARE NOT SHOWN.  
 LEVELS ARE BASED ON AUSTRALIAN HEIGHT DATUM (AHD) USING SSM 15774 WITH RL 52.762 (AHD).  
 RIDGE & GUTTER HEIGHTS HAVE BEEN OBTAINED BY INDIRECT METHOD AND ARE ACCURATE TO ± 0.05m.  
 CONTOURS SHOWN DEPICT THE TOPOGRAPHY, EXCEPT AT SPOT LEVELS SHOWN THEY DO NOT REPRESENT THE EXACT LEVEL AT ANY PARTICULAR POINT. THE SPOT LEVELS ARE TRUE FOR THEIR POSITION, AND ARE INTENDED TO BE USEFUL TO REPRESENT THE GENERAL TERRAIN. CARE SHOULD BE TAKEN IF EXTRAPOLATING.  
 JUNE 2022  
 SURVEY ADJUSTED TO MGA GDA2020 COORDINATES. ORIGIN: PMS74624  
 CLASS: B  
 ORIENTATION: SSM 15774

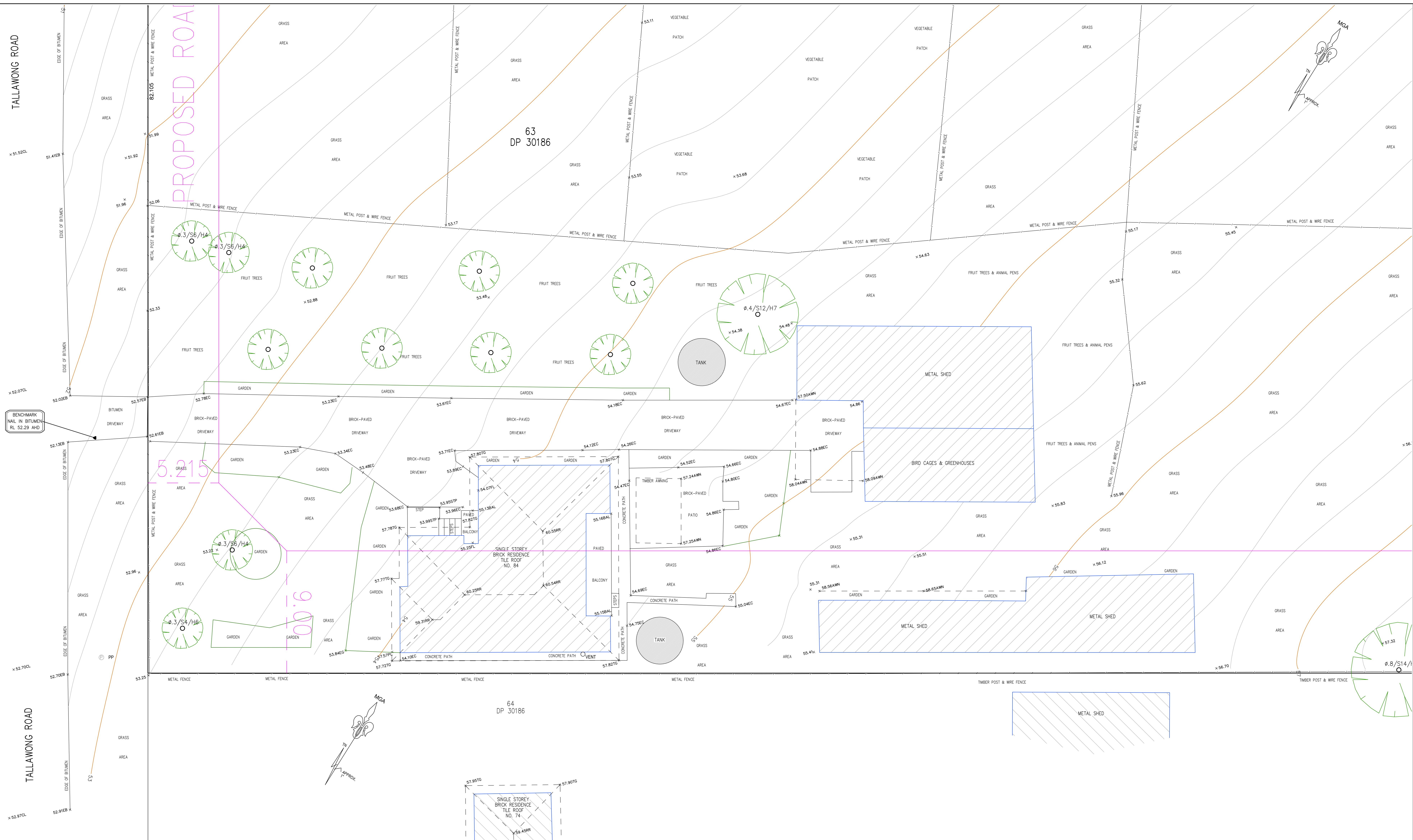

**LEGEND**

BENCH MARK	▲
TELSTRA PIT	⊠ TEL
ELECTRIC LIGHT POLE	⊕ LP
POWER POLE	⊕ PP
SIGN POST	⊕ SP
SEWER INSPECTION PIT	⊕ SIP
SEWER VENT	⊕ SEWER
MANHOLE	⊕ MH
SEWER MANHOLE	⊕ SMH
STOP VALVE	⊕ SV
WATER HYDRANT	⊕ HYD
WATER METER	⊕ WM
GAS METER	⊕ G
STATE SURVEY MARK	⊕ SSM

**NOTE:**  
 INFORMATION CONTAINED IN THIS PLAN IS THE COPYRIGHT OF TOTAL SURVEYING SOLUTIONS. THE USE OR DUPLICATION WITHOUT THE WRITTEN CONSENT OF TOTAL SURVEYING SOLUTIONS CONSTITUTES AN INFRINGEMENT OF COPYRIGHT.

REVISION No.	REVISION DATE:	COMMENT:
C	26/6/2025	SURVEY MODEL MOVED TO MGA GDA2020 COORDINATES
D	25/8/2025	PROPOSED DEVELOPMENT IMPORTED FROM REVIT MODEL
E	29/8/2025	PROPOSED ROAD DEDICATION WIDTHS ADDED

**LEGEND:**  
 EC - EDGE OF CONCRETE  
 EB - EDGE OF BITUMEN  
 TG - TOP OF GUTTER  
 RR - ROOF RIDGE  
 FL - FLOOR LEVEL  
 Ø.4/S10/H16 - DIAMETER/SPREAD/HEIGHT  
 TB - TOP OF BANK  
 BB - BOTTOM OF BANK  
 AWN - AWNING

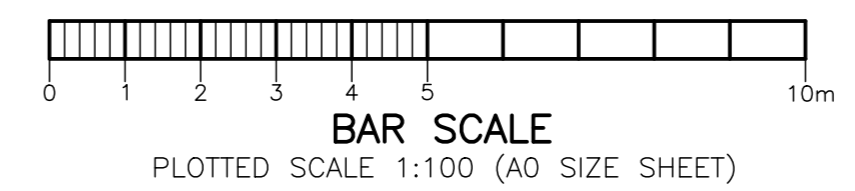

**PLAN SHOWING DETAIL & LEVELS**  
**OVER LOT 63 IN DP 30186**  
 CLIENT: LK GROUP - LKPG SPV 6 PTY LTD  
 PROJECT: ROUSE HILL  
 ADDRESS: 84 TALLAWONG ROAD, ROUSE HILL

JOB No.: 170515 (250462)	LGA: BLACKTOWN
PLAN No.: 170515 REV E	DATUM: AHD
DATE: 11/8/2017	SCALE: 1:250@A0
DRAWN: SF	CONT. INTERVAL: 0.25m
CHK: GS	SHEET 2 OF 6

**NOTE:**

BOUNDARIES HAVE BEEN DETERMINED BY SURVEY ON 22/03/2017.  
 PRIOR TO ANY CONSTRUCTION WORK, SURVEY MARKS SHOULD BE PLACED TO DEFINE THE PROPERTY BOUNDARIES.  
 SERVICES SHOWN ARE INDICATIVE ONLY. POSITIONS ARE BASED ON SURFACE INDICATOR(S) LOCATED DURING FIELD SURVEY. CONFIRMATION OF THE EXACT POSITION SHOULD BE MADE PRIOR TO ANY EXCAVATION WORK. OTHER SERVICES MAY EXIST WHICH ARE NOT SHOWN.  
 LEVELS ARE BASED ON AUSTRALIAN HEIGHT DATUM (AHD) USING SSM 15774 WITH RL 52.762 (AHD).  
 RIDGE & GUTTER HEIGHTS HAVE BEEN OBTAINED BY INDIRECT METHOD AND ARE ACCURATE TO ± 0.05m.  
 CONTOURS SHOWN DEPICT THE TOPOGRAPHY. EXCEPT AT SPOT LEVELS SHOWN THEY DO NOT REPRESENT THE EXACT LEVEL AT ANY PARTICULAR POINT. THE SPOT LEVELS ARE TRUE FOR THEIR POSITION, AND ARE INTENDED TO BE USEFUL TO REPRESENT THE GENERAL TERRAIN. CARE SHOULD BE TAKEN IF EXTRAPOLATING.  
 JUNE 2022  
 SURVEY ADJUSTED TO MGA GDA2020 COORDINATES.  
 ORIGIN: PMS74624  
 CLASS: B  
 ORIENTATION: SSM 15774

62  
 DP 30186

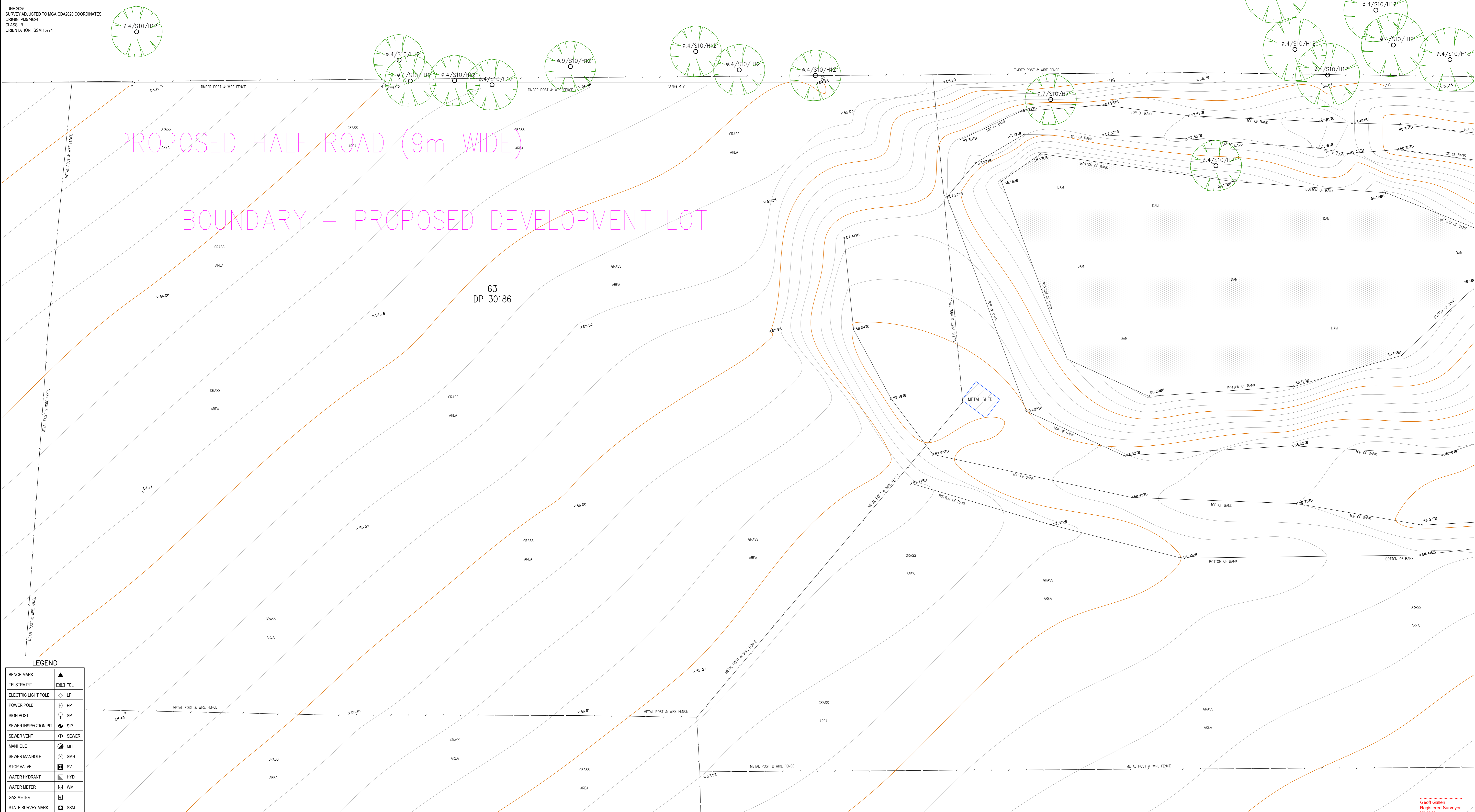
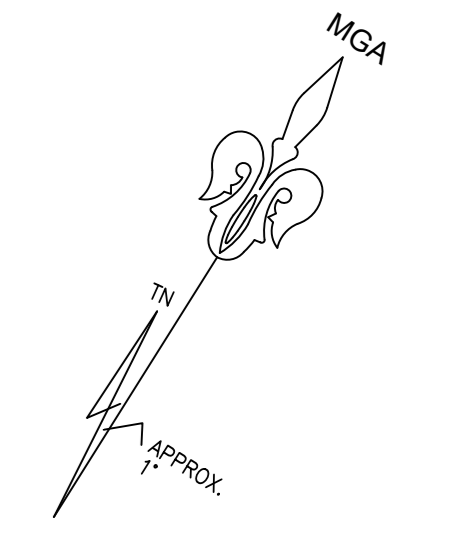

**LEGEND**

BENCH MARK	▲
TELSTRA PIT	⊠ TEL
ELECTRIC LIGHT POLE	⊠ LP
POWER POLE	⊠ PP
SIGN POST	⊠ SP
SEWER INSPECTION PIT	⊠ SIP
SEWER VENT	⊠ SEWER
MANHOLE	⊠ MH
SEWER MANHOLE	⊠ SMH
STOP VALVE	⊠ SV
WATER HYDRANT	⊠ HYD
WATER METER	⊠ WM
GAS METER	⊠ G
STATE SURVEY MARK	⊠ SSM

**TSS TOTAL SURVEYING SOLUTIONS**  
 ARTARMON | CAMDEN | MANLY VALE

**NOTE:**  
 INFORMATION CONTAINED IN THIS PLAN IS THE COPYRIGHT OF TOTAL SURVEYING SOLUTIONS. THE USE OR DUPLICATION WITHOUT THE WRITTEN CONSENT OF TOTAL SURVEYING SOLUTIONS CONSTITUTES AN INFRINGEMENT OF COPYRIGHT.

REVISION No.	REVISION DATE:	COMMENT:
C	26/6/2025	SURVEY MODEL MOVED TO MGA GDA2020 COORDINATES
D	25/8/2025	PROPOSED DEVELOPMENT IMPORTED FROM REVIT MODEL
E	29/8/2025	PROPOSED ROAD DEDICATION WIDTHS ADDED

**LEGEND:**

EC - EDGE OF CONCRETE	TB - TOP OF BANK
EB - EDGE OF BITUMEN	BB - BOTTOM OF BANK
TG - TOP OF GUTTER	AWN - AWNING
RR - ROOF RIDGE	
FL - FLOOR LEVEL	
Ø 4/S10/H12 - DIAMETER/SPREAD/HEIGHT	

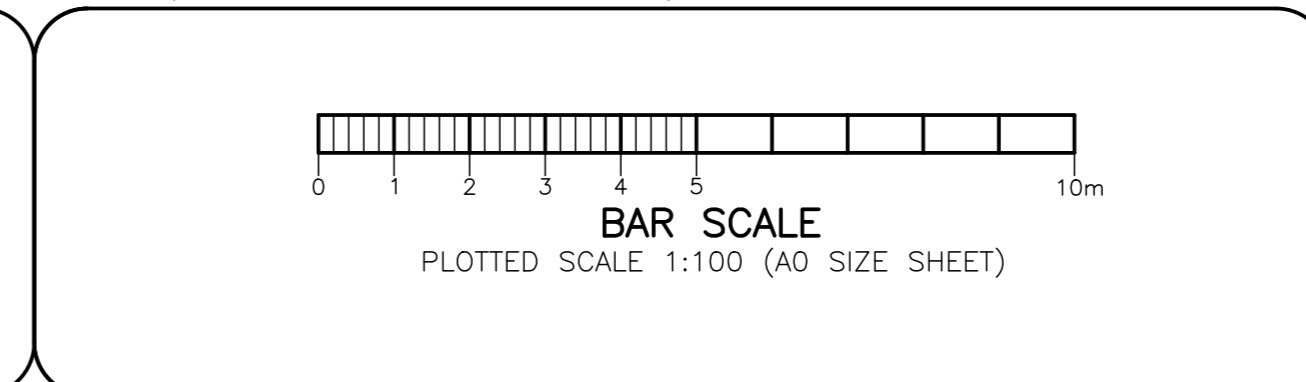

**PLAN SHOWING DETAIL & LEVELS  
 OVER LOT 63 IN DP 30186**

CLIENT: LK GROUP - LKPG SPV 6 PTY LTD	PROJECT: ROUSE HILL	ADDRESS: 84 TALLAWONG ROAD, ROUSE HILL
---------------------------------------	---------------------	--

JOB No.: 170515 (250462)	LGA: BLACKTOWN
PLAN No.: 170515 REV E	DATUM: AHD
DATE: 11/8/2017	SCALE: 1:250@A0
DRAWN: SF	CONT. INTERVAL: 0.25m
CHK: GS	SHEET 3 OF 6

Geoff Galen  
 Registered Surveyor  
 N° 1063

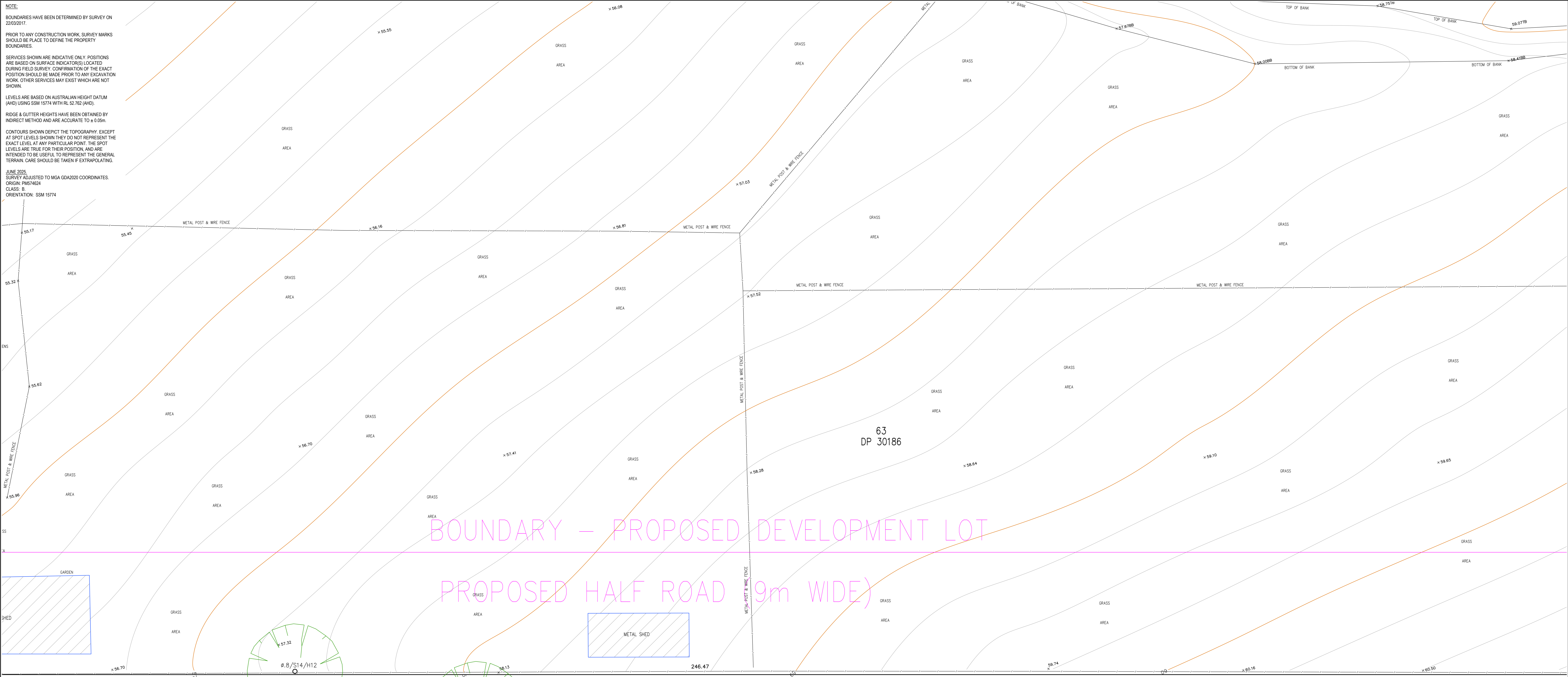

BOUNDARY – PROPOSED DEVELOPMENT LOT  
 PROPOSED HALF ROAD (9m WIDE)

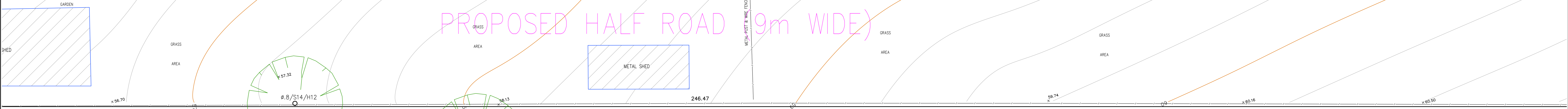

**LEGEND**

BENCH MARK	▲
TELSTRA PIT	TEL
ELECTRIC LIGHT POLE	LP
POWER POLE	PP
SIGN POST	SP
SEWER INSPECTION PIT	SIP
SEWER VENT	SEWER
MANHOLE	MH
SEWER MANHOLE	SMH
STOP VALVE	SV
WATER HYDRANT	HYD
WATER METER	WM
GAS METER	GM
STATE SURVEY MARK	SSM

NOTE:  
 INFORMATION CONTAINED IN THIS PLAN IS THE COPYRIGHT OF TOTAL SURVEYING SOLUTIONS. THE USE OR DUPLICATION WITHOUT THE WRITTEN CONSENT OF TOTAL SURVEYING SOLUTIONS CONSTITUTES AN INFRINGEMENT OF COPYRIGHT.

REVISION No.	REVISION DATE:	COMMENT:
C	26/6/2025	SURVEY MODEL MOVED TO MGA GDA2020 COORDINATES
D	25/8/2025	PROPOSED DEVELOPMENT IMPORTED FROM REVIT MODEL
E	29/8/2025	PROPOSED ROAD DEDICATION WIDTHS ADDED

**LEGEND:**

EC - EDGE OF CONCRETE	TB - TOP OF BANK
EB - EDGE OF BITUMEN	BB - BOTTOM OF BANK
TG - TOP OF GUTTER	AWN - AWNING
RR - ROOF RIDGE	
FL - FLOOR LEVEL	
Ø.4/S10/H16 - DIAMETER/SPREAD/HEIGHT	

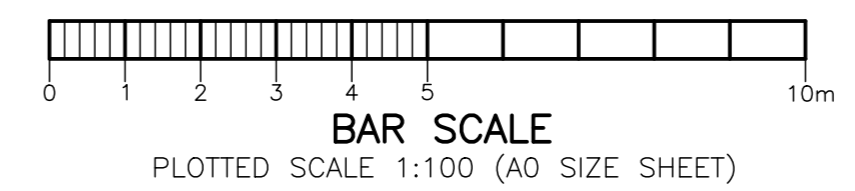

**PLAN SHOWING DETAIL & LEVELS  
 OVER LOT 63 IN DP 30186**

CLIENT: LK GROUP - LKPG SPV 6 PTY LTD	PROJECT: ROUSE HILL	ADDRESS: 84 TALLAWONG ROAD, ROUSE HILL
---------------------------------------	---------------------	--

JOB No.: 170515 (250462)	LGA: BLACKTOWN
PLAN No.: 170515 REV E	DATUM: AHD
DATE: 11/8/2017	SCALE: 1:250@A0
DRAWN: SF	CONT. INTERVAL: 0.25m
CHK: GS	SHEET 4 OF 6

MGA  
 APPROX  
 Geoff Gallen  
 Registered Surveyor  
 N° 1083

NOTE:  
 BOUNDARIES HAVE BEEN DETERMINED BY SURVEY ON 22/03/2017.  
 PRIOR TO ANY CONSTRUCTION WORK SURVEY MARKS SHOULD BE PLACED TO DEFINE THE PROPERTY BOUNDARIES.  
 SERVICES SHOWN ARE INDICATIVE ONLY. POSITIONS ARE BASED ON SURFACE INDICATOR(S) LOCATED DURING FIELD SURVEY. CONFIRMATION OF THE EXACT POSITION SHOULD BE MADE PRIOR TO ANY EXCAVATION WORK. OTHER SERVICES MAY EXIST WHICH ARE NOT SHOWN.  
 LEVELS ARE BASED ON AUSTRALIAN HEIGHT DATUM (AHD) USING SSM 15774 WITH RL 52.762 (AHD).  
 RIDGE & GUTTER HEIGHTS HAVE BEEN OBTAINED BY INDIRECT METHOD AND ARE ACCURATE TO ± 0.05m.  
 CONTOURS SHOWN DEPICT THE TOPOGRAPHY. EXCEPT AT SPOT LEVELS SHOWN THEY DO NOT REPRESENT THE EXACT LEVEL AT ANY PARTICULAR POINT. THE SPOT LEVELS ARE TRUE FOR THEIR POSITION, AND ARE INTENDED TO BE USEFUL TO REPRESENT THE GENERAL TERRAIN. CARE SHOULD BE TAKEN IF EXTRAPOLATING.  
 JUNE 2022  
 SURVEY ADJUSTED TO MGA GDA2020 COORDINATES.  
 ORIGIN: PMS74624  
 CLASS: B  
 ORIENTATION: SSM 15774

62  
 DP 30186

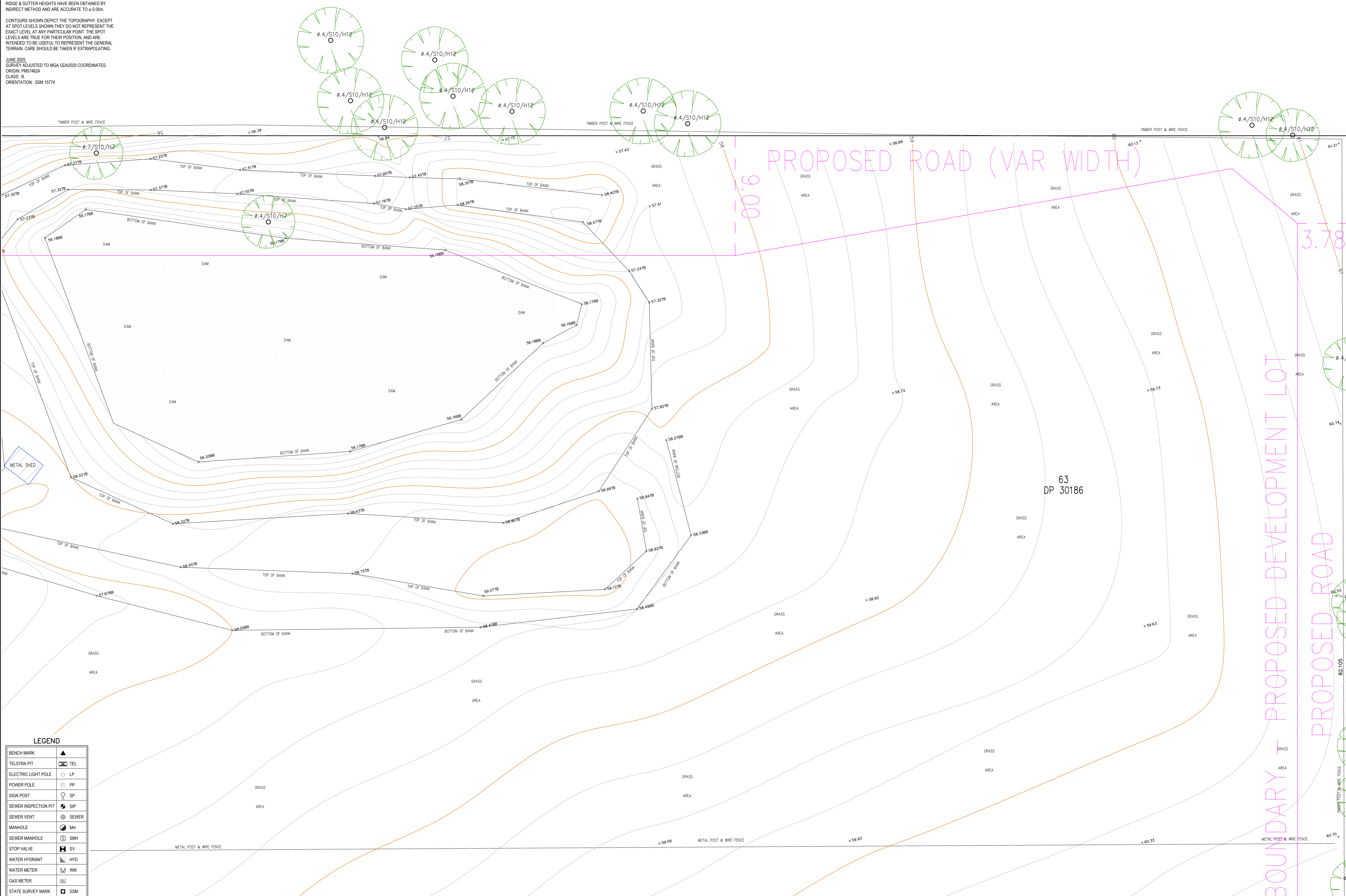
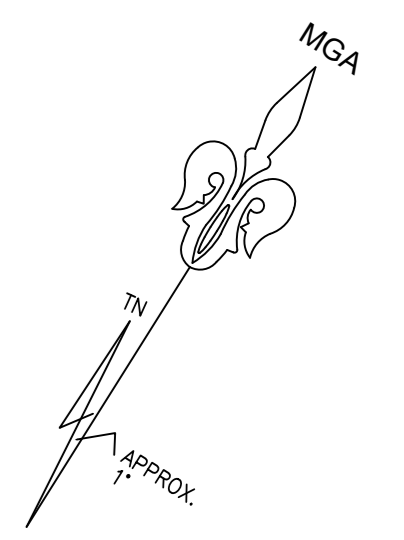

NOTE:  
 BOUNDARIES HAVE BEEN DETERMINED BY SURVEY ON 22/03/2017.  
 PRIOR TO ANY CONSTRUCTION WORK, SURVEY MARKS SHOULD BE PLACED TO DEFINE THE PROPERTY BOUNDARIES.  
 SERVICES SHOWN ARE INDICATIVE ONLY. POSITIONS ARE BASED ON SURFACE INDICATOR(S) LOCATED DURING FIELD SURVEY. CONFIRMATION OF THE EXACT POSITION SHOULD BE MADE PRIOR TO ANY EXCAVATION WORK. OTHER SERVICES MAY EXIST WHICH ARE NOT SHOWN.  
 LEVELS ARE BASED ON AUSTRALIAN HEIGHT DATUM (AHD) USING SSM 15774 WITH RL 52.762 (AHD).  
 RIDGE & GUTTER HEIGHTS HAVE BEEN OBTAINED BY INDIRECT METHOD AND ARE ACCURATE TO ± 0.05m.  
 CONTOURS SHOWN DEPICT THE TOPOGRAPHY. EXCEPT AT SPOT LEVELS SHOWN THEY DO NOT REPRESENT THE EXACT LEVEL AT ANY PARTICULAR POINT. THE SPOT LEVELS ARE TRUE FOR THEIR POSITION, AND ARE INTENDED TO BE USEFUL TO REPRESENT THE GENERAL TERRAIN. CARE SHOULD BE TAKEN IF EXTRAPOLATING.  
 JUNE 2025  
 SURVEY ADJUSTED TO MGA GDA2020 COORDINATES.  
 ORIGIN: PMS74624  
 CLASS: B  
 ORIENTATION: SSM 15774

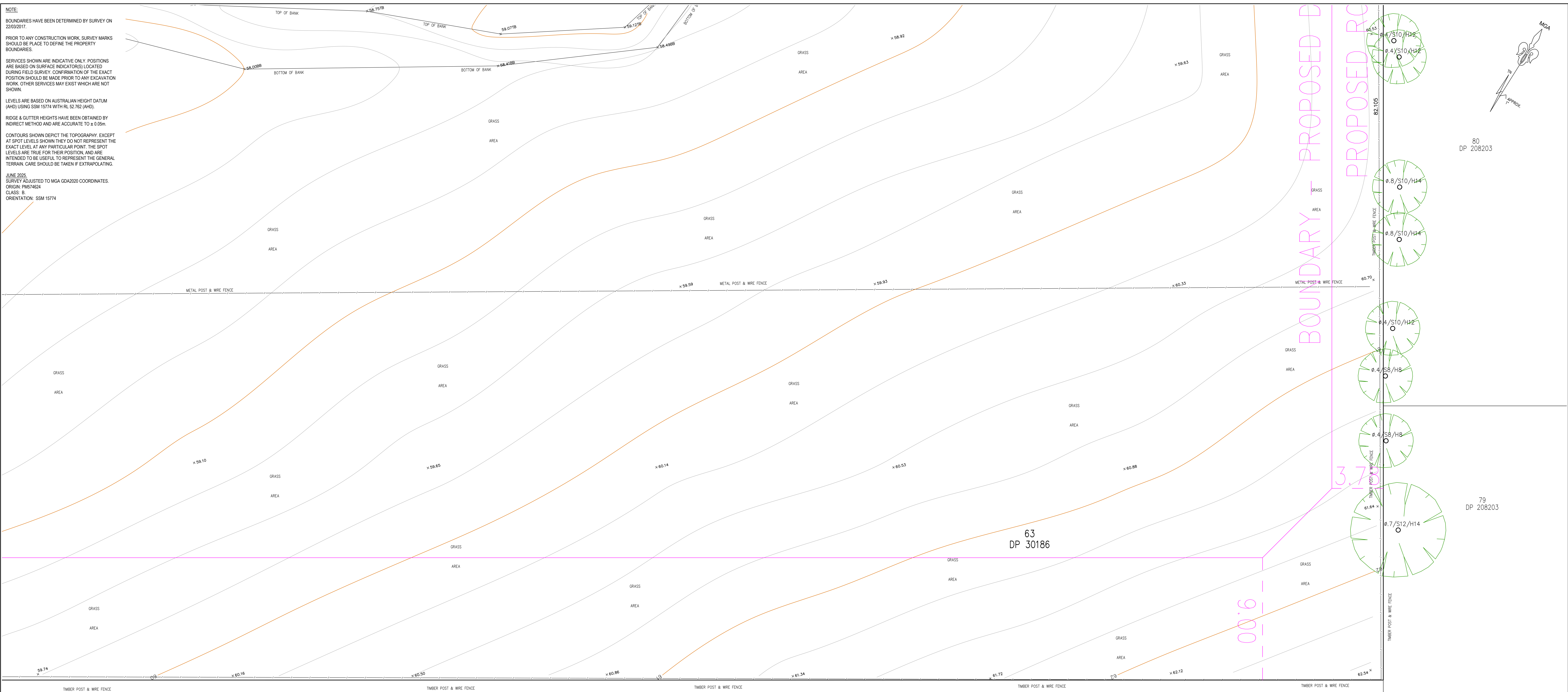

**LEGEND**

BENCH MARK	▲
TELSTRA PIT	TEL
ELECTRIC LIGHT POLE	LP
POWER POLE	PP
SIGN POST	SP
SEWER INSPECTION PIT	SIP
SEWER VENT	SEWER
MANHOLE	MH
SEWER MANHOLE	SMH
STOP VALVE	SV
WATER HYDRANT	HYD
WATER METER	WM
GAS METER	GM
STATE SURVEY MARK	SSM

NOTE:  
 INFORMATION CONTAINED IN THIS PLAN IS THE COPYRIGHT OF TOTAL SURVEYING SOLUTIONS. THE USE OR DUPLICATION WITHOUT THE WRITTEN CONSENT OF TOTAL SURVEYING SOLUTIONS CONSTITUTES AN INFRINGEMENT OF COPYRIGHT.

REVISION No.	REVISION DATE:	COMMENT:
C	26/6/2025	SURVEY MODEL MOVED TO MGA GDA2020 COORDINATES
D	25/8/2025	PROPOSED DEVELOPMENT IMPORTED FROM REVIT MODEL
E	29/8/2025	PROPOSED ROAD DEDICATION WIDTHS ADDED

**LEGEND:**

EC - EDGE OF CONCRETE	TB - TOP OF BANK
EB - EDGE OF BITUMEN	BB - BOTTOM OF BANK
TG - TOP OF GUTTER	AWN - AWNING
RR - ROOF RIDGE	
FL - FLOOR LEVEL	
Ø 4/S10/H16 - DIAMETER/SPREAD/HEIGHT	

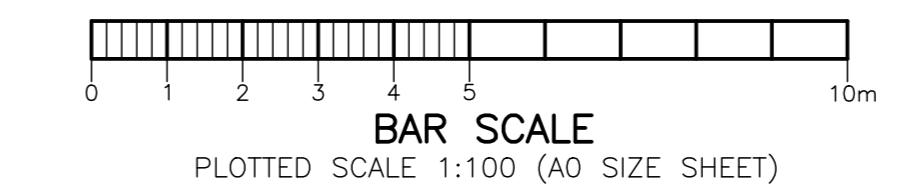

**PLAN SHOWING DETAIL & LEVELS  
 OVER LOT 63 IN DP 30186**

CLIENT: LK GROUP - LKPG SPV 6 PTY LTD	PROJECT: ROUSE HILL	ADDRESS: 84 TALLAWONG ROAD, ROUSE HILL
---------------------------------------	---------------------	--

JOB No.: 170515 (250462)	LGA: BLACKTOWN
PLAN No.: 170515 REV E	DATUM: AHD
DATE: 11/8/2017	SCALE: 1:250@A0
DRAWN: SF	CONT. INTERVAL: 0.25m
CHK: GS	SHEET 6 OF 6

Geoff Gallen  
 Registered Surveyor  
 N° 1065