



**VECTOR**  
ALLIANCE

# JULIUS AVENUE DATA CENTRE

---

## PRELIMINARY FIRE SAFETY STRATEGY

**Revision:** 1

**Date:** 09 December 2025

**Document Reference:** 24135-005

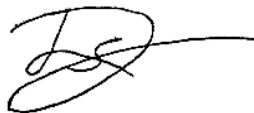
DOCUMENT ISSUE REGISTER		
Date	Revision	Description
09/12/2025	1	Draft issue for stakeholder review.
AUTHOR		
 <b>Ashtad Sadrzadeh</b> Fire Safety Engineer		
REVIEWER		
 <b>Damian La Starza</b> Certifier – Fire Safety (BDC05454)		

## EXECUTIVE SUMMARY

This report has been prepared by Vector Alliance to communicate the Preliminary Fire Safety Strategy for the proposed Data Centre Building located at 6-8 Julius Avenue, North Ryde NSW 2113.

A State Significant Development Application (SSDA) is proposed to be lodged for the Julius Avenue Data Centre Development. The intent of this report is to form part of the SSDA submission to assist the Department of Planning, Housing and Infrastructure (DPHI) and associated referral authorities in undertaking an informed review of the development from a Fire Safety perspective.

The Preliminary Fire Safety Strategy include required Essential Fire Safety Measures and proposed standards of construction, commissioning, management, use, and maintenance. It also includes advice with respect to other elements applicable to fire safety, including risk mitigation strategies pertaining to diesel fuel and lithium-ion batteries. The Preliminary Fire Safety Strategy will be subject to change as the design develops during future design phases.

Unless explicitly stated within this report, the building design is assumed to comply with the Deemed to Satisfy (DtS) Provisions of the National Construction Code Volume 1 2022 Amendment 2 (BCA). The Fire Safety Strategy integrates performance-based design elements as per the Performance Solution Summary Table presented in Table 1.

*Table 1 – Performance Solution Summary Table.*

Performance Solution	BCA DtS Clause(s)	BCA Performance Requirement(s)
Rationalised Fire Resistance Levels	C2D2, C3D8, Spec 5	C1P1, C1P2
Battery Rooms Supply and Exhaust Dampers	C4D15	C1P2, C1P8
Extended exit travel distances	D2D5, D2D6	D1P4, E2P2
Fire hydrant system outside of scope of AS 2419.1:2021	E1D2	E1P3
Omission of fire hose reels	E1D3	E1P1, E1P2
Fire brigade booster assembly location	E1D2, E1D4	E1P3, E1P4
Sprinkler Valve Rooms access	E1D4	E1P4
Tail-end fire sprinkler system area of protection	E1D4	E1P4
Omission of Stair Pressurisation Systems	E2D4	E2P2
Omission of Zone Pressurisation Systems	E2D6	E2P2
Omission of Emergency Warning Intercommunication System	E4D9	E4P3

The Julius Avenue Data Centre Building is proposed to contain lithium-ion battery energy storage systems within the building and have diesel fuel generators located external to the building. This report describes elements of the design proposed to address the special hazards presented by these systems.

This report has been prepared in accordance with the Australian Fire Engineering Guidelines 2021 (AFEG) and precedes the Performance Based Design Brief (PBDB) for the Julius Avenue Data Centre Building.

## Table of Contents

<b>EXECUTIVE SUMMARY</b> .....	<b>3</b>
<b>1 INTRODUCTION</b> .....	<b>5</b>
1.1 SCOPE OF THE PROJECT .....	5
1.2 REGULATORY FRAMEWORK .....	7
1.3 RELEVANT STAKEHOLDERS .....	7
1.4 REFERENCE DOCUMENTATION .....	9
1.5 OBJECTIVES .....	10
1.6 ASSUMPTIONS AND LIMITATIONS .....	11
<b>2 DEVELOPMENT CHARACTERISTICS</b> .....	<b>12</b>
2.1 SITE LOCATION AND ACCESS .....	12
2.2 BUILDING CHARACTERISTICS .....	16
2.3 DANGEROUS GOODS PRESENT ON SITE .....	18
2.4 DOMINANT OCCUPANT CHARACTERISTICS .....	19
<b>3 PRELIMINARY FIRE SAFETY STRATEGY</b> .....	<b>20</b>
3.1 FIRE RESISTANCE LEVELS .....	20
3.2 FIRE COMPARTMENTATION .....	20
3.3 PROVISIONS FOR ESCAPE .....	20
3.4 FIRE HYDRANT SYSTEM .....	21
3.5 AUTOMATIC FIRE SUPPRESSION SYSTEMS .....	22
3.6 PORTABLE FIRE EXTINGUISHERS .....	22
3.7 FIRE CONTROL CENTRE .....	23
3.8 AUTOMATIC FIRE DETECTION AND ALARM SYSTEM .....	23
3.9 AIR HANDLING SYSTEMS .....	23
3.10 OFF GAS DETECTION AND ALARM SYSTEM .....	24
3.11 OFF GAS VENTILATION SYSTEM .....	24
3.12 EXIT AND EMERGENCY LIGHTING .....	24
3.13 DIESEL FUEL GENERATORS .....	25
3.14 LITHIUM-ION BATTERY ENERGY STORAGE SYSTEMS .....	28
3.15 EV AND EV CHARGING .....	30
3.16 STANDARDS OF CONSTRUCTION AND COMMISSIONING .....	30
3.17 STANDARDS OF MANAGEMENT, USE AND MAINTENANCE .....	30

# 1 INTRODUCTION

## 1.1 SCOPE OF THE PROJECT

This report has been prepared by Vector Alliance to communicate the Preliminary Fire Safety Strategy for the proposed North Ryde Data Centre located at 6-8 Julius Avenue, North Ryde NSW 2113. The development of North Ryde Data Centre is understood to comprise the following:

- Site preparation works, including tree removal.
- Earthworks and additional site retaining.
- Infrastructure comprising civil works and utilities servicing.
- Construction of a data centre including the following:
  - Ground level loading dock, services plantrooms and car parking for 38 cars, including 2 accessible.
  - 8 data halls across four (4) storeys with an IT load of 76 MW and a maximum power consumption of 120 MW, plus rooftop plant.
  - Three (3) storey office/front of house building.
  - Five (5) storey enclosed generator gantry to rear of data centre.
- New Ausgrid precinct-wide 132 kilovolt (KV) Sub transmission Switching Station (STSS).
- One (1) new public street along the southern part of the Site.
- A new pedestrian through-site link from Julius Avenue to Richardson Place.
- Complimentary landscaping and offset planting.

The proposal includes works as identified in Table 2.

*Table 2 – Development Particulars.*

Component	Detail
Site Area	28,630 m <sup>2</sup>
Primary Land Use	Data Centre (16,647 m <sup>2</sup> GFA)
Ancillary Land Uses	Office premises (868 m <sup>2</sup> GFA)
Gross Floor Area	16,647 m <sup>2</sup>
Floor Space Ratio	0.58:1
IT Load	76 MW
Maximum Power Consumption	120 MW
Building Height	40 m
Car Parking	38 car parking spaces (including 2 accessible).
Landscaping/trees	Total landscaping and tree removal to be confirmed.
Back-Up Generators	48 x 3 MW diesel back-up generators (Data Centre) + 1 x 1 MW diesel back-up generator (Office)
Dangerous Goods	955 kL diesel storage capacity (Data Centre = 12 x 75kL bulk tanks + 48 x 1kL day tanks + Office = 1 x 6kL tank + 1kL day tank)
Estimated Jobs	Total estimated jobs (construction and operation) to be confirmed.

Refer to Figure 1 and Figure 2 for a site plan depicting the proposed North Ryde Data Centre development and 3D massing view, respectively.

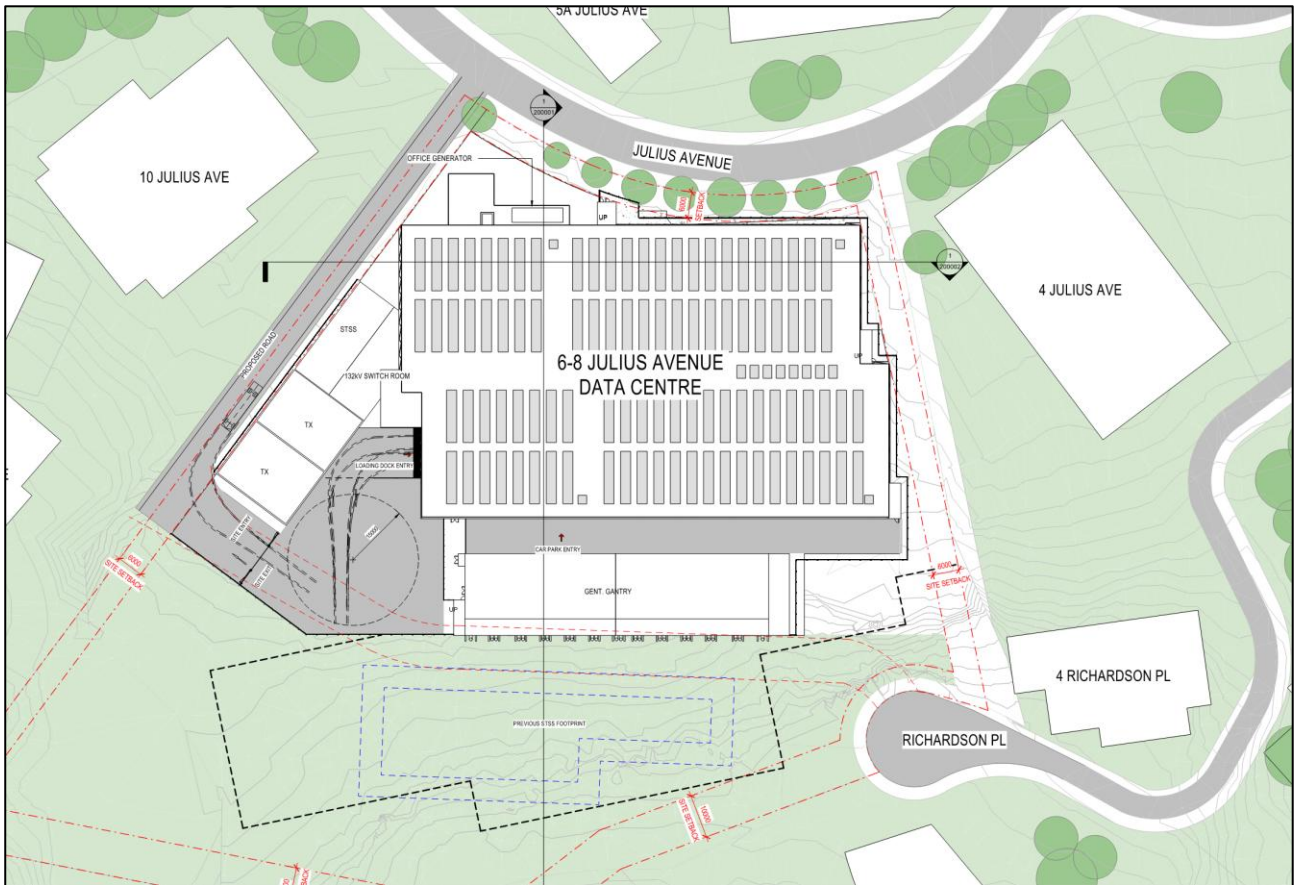

Figure 1 – Proposed North Ryde Data Centre Site Plan.



Figure 2 – Proposed North Ryde Data Centre Site – 3D Massing View.

All works shall be undertaken in accordance with the National Construction Code Volume 1 2022 Amendment 2 (BCA) and/or future edition(s) of the BCA depending on the date of approval for the construction. The design is proposed to incorporate a combination of Deemed-to-Satisfy (DtS) Solutions and Performance Solutions to comply with the Performance Requirements of the BCA.

This document comprises the Preliminary Fire Safety Strategy and has been prepared to communicate proposed Essential Fire Safety Measures, standards of construction, commissioning, management, use, and maintenance. The Preliminary Fire Safety Strategy will be subject to change as the design develops further.

This report has been prepared in accordance with the Australian Fire Engineering Guidelines 2021 (AFEG) and precedes the Performance Based Design Brief (PBDB).

## 1.2 REGULATORY FRAMEWORK

The project must meet the requirements of applicable Building Legislation, specifically the Environmental Planning and Assessment Act 1979 and the Environmental Planning and Assessment (Development Certification and Fire Safety) Regulations 2021. The BCA is adopted through this Legislation and provides technical building design requirements.

Building compliance is achieved through compliance with the BCA Performance Requirements. Compliance with the Performance Requirements can be demonstrated by satisfying the DtS Provisions, the requirements of a Performance Solution, or a combination of both.

Fire Safety Engineering assessment and reporting is undertaken to demonstrate that Performance Solutions pertaining to fire safety comply with the Performance Requirements. A Performance Solution is an aspect of the building design that does not satisfy the DtS Provisions but has been demonstrated to:

- Comply with all relevant Performance Requirements; or
- Be at least equivalent to the DtS Provisions.

A Performance Solution must be demonstrated to comply with the Performance Requirements using one or a combination of the methods prescribed in Clause A2G2 of the BCA.

## 1.3 RELEVANT STAKEHOLDERS

Engagement of stakeholders is fundamental to the Fire Safety Engineering process, required to ensure stakeholder requirements are considered in the development of a building solution. Stakeholders are also required to be informed of the Fire Safety Strategy to ensure the strategy is adopted as part of the design and construction to the building, in addition to ongoing maintenance, management and use of the building.

Relevant stakeholders at this stage of the Fire Safety Engineering process have been identified and listed in Table 3.

Table 3 – Schedule of Project Stakeholders.

Stakeholder	Representative	Role
ISPT	Alex Hancock Matthew Cox	Building Owner and Operator
Logic Projects	Dan D'Ambrosio Nathan Smith	Project Manager
Willow Town Planning	Asher Richardson Ash Unni	Town Planner
BM+G	Dean Goldsmith	BCA Consultant
Greenbox	Arash Daryaei Andrew Owens Mike Lodge	Architect
Arup	David Kim	Acoustics
	Clea Stirling	Project Manager
	Nicholas Ng	Mechanical Engineer
	Andrew Shannon Neil Langford Moe Esady	Hydraulic and Fire Services Engineer
IGS	Mays Chalak Vince Nigro	Electrical Engineer
TTW	Wystan Alexander	Structural Engineer
	Andrew Monteath	Civil Engineer
BMM Engineering	John Kan	Security Consultant
Bushfire Hazard Solutions	Andrew Muirhead	Bushfire Consultant
FRNSW	TBC	Fire Authority
Vector Alliance	Ashtad Sadrzadeh	Fire Safety Engineer
	Damian La Starza	Certifier - Fire Safety

## 1.4 REFERENCE DOCUMENTATION

The FSS has been based on correspondence and drawings listed in Table 4 and Table 5, respectively.

*Table 4 – Schedule of Referenced Documents.*

Document	Date	Revision
BCA Report - 240434	4 December 2025	2
Bushfire Assessment Report – 250413B	5 December 2025	6

*Table 5 – Schedule of Referenced Drawings.*

Discipline	Drawing Number	Drawing Name	Date	Revision
Architectural	010003	Site Plan	25.11.2025	4
Architectural	010004	Site Plan Easement Plan	05.12.2025	2
Architectural	101001	Ground Floor Plan	25.11.2025	2
Architectural	101101	Level 01 Plan	25.11.2025	2
Architectural	101201	Level 02 Plan	25.11.2025	2
Architectural	101301	Level 03 Plan	25.11.2025	2
Architectural	101401	Level 04 Plan	25.11.2025	2
Architectural	101501	Level 05 Plan	25.11.2025	2
Architectural	101601	Level 06 Plan	25.11.2025	2
Architectural	150001	Building Elevation 01	25.11.2025	2
Architectural	150002	Building Elevation 02	25.11.2025	2
Architectural	200001	Building Section – Sheet 01	25.11.2025	1
Architectural	200002	Building Section – Sheet 02	25.11.2025	1
Architectural	040001	GFA Calculations Diagram	09.12.2025	1

## 1.5 OBJECTIVES

The fire safety objectives have been developed in collaboration with project stakeholders. Objectives pertaining to Fire Safety Engineering are categorised as building regulatory objectives, other regulatory objectives, and non-regulatory objectives.

Building regulatory objectives applicable to the project are as identified in the BCA. The broad objectives pertaining to fire safety are prescribed in Objectives C1O1, D1O1, E1O1, E2O1, and E4O1. These objectives are summarised as follows:

- Safeguard people from illness or injury due to a fire in a building.
- Safeguard occupants from illness or by warning them of a fire so that they may safely evacuate.
- Safeguard occupants from illness or injury while evacuating a building during a fire or other emergency.
- In an emergency, safeguard occupants from injury by:
  - Having adequate visibility.
  - Having adequate identification of exits and paths of travel to exits.
  - Being made aware of the emergency.
- Facilitate the activities of emergency services personnel.
- Avoid the spread of fire between buildings.
- Protect other property from physical damage caused by structural failure of a building as a result of fire.
- Provide facilities for occupants and the fire brigade to undertake fire-fighting operations.
- Provide, as far as reasonable, people with safe, equitable and dignified access to:
  - A building.
  - The services and facilities within a building.

Other regulatory objectives are those presented in alternative Legislation and are generally broad in nature. Other regulatory objectives applicable to the project are summarised as follows:

- Environmental protection.
- Occupational health and safety.
- Accessibility.
- Fire brigade operational requirements.
- Land use and planning matters.

Non-regulatory objectives are additional objectives set by other stakeholders. The non-regulatory objectives pertaining to fire safety and applicable to the subject building are understood to comprise the following:

- Information security.
- Property and asset protection in accordance with ISTP, their clients, and insurer requirements.
- Access for large equipment installation and replacement.
- Minimise the extent of disruption and modification works required to achieve BCA compliance.
- Mitigate the likelihood and consequence of spurious fire alarms.

## 1.6 ASSUMPTIONS AND LIMITATIONS

The following assumptions and limitations are applicable to the Fire Safety Engineering assessment and reporting:

- The contents of this report are only applicable to the subject site and the current design and shall not be utilised for other projects.
- Unless explicitly stated otherwise within this report, the building design is assumed to comply with the BCA DtS Provisions applicable to fire safety.
- This assessment is based on documentation explicitly referenced within this report. Changes to this documentation or the provision of additional documentation may affect the outcomes of this assessment.
- This assessment does not address compliance with regulatory requirements associated with environmental, disability discrimination, and occupational health and safety.
- This assessment is limited to risks associated with accidental fire starts, considering a single fire occurring at any one time. Arson and other malicious acts that may result in a fire have not been identified as a considerable risk and therefore have not been assessed.
- This assessment is limited to addressing life safety and does not address property protection or business continuity following an incident. Client requirements exceeding BCA DtS Provisions have been adopted at the direction of the Client and included as part of the Fire Safety Strategy.
- This assessment is not based on achieving absolute safety, as there will always be a finite level of risk. The intent of the Fire Safety Engineering assessment is to demonstrate an adequate level of fire safety by demonstrating compliance with the BCA Performance Requirements.
- The diesel fuel generator assessment is limited to providing an overview of fire safety requirements applicable to the storage of diesel fuel and does not specify all ancillary compliance requirements or address the safe handling and use of the diesel fuel on site or general emergency management protocols.
- The diesel fuel generator assessment is based on the requirements of AS 1940:2017 and does not assess compliance with International Standards or Environmental Protection Authority requirements unless specifically noted within AS 1940:2017 or this report.
- The current edition of the BCA and referenced standards do not specifically address special risks associated with lithium-ion batteries. Therefore, Vector Alliance has relied on the material available at the time of writing this report. Risk mitigation strategies associated with lithium-ion battery energy storage systems are the subject of ongoing research. The analysis presented in this report represents the current understanding of the subject matter and is subject to limitations of the available data at the time of writing the report.

## 2 DEVELOPMENT CHARACTERISTICS

### 2.1 SITE LOCATION AND ACCESS

The proposed Julius Avenue Data Centre Development is located at 6-8 Julius Avenue, North Ryde NSW 2113. The site is proposed to be accessed via Julius Avenue on the north-west of the site. Access along the western boundary of the site is provided via a private access road as shown on Figure 1.

The private access road has minimum width of 6 m and sufficient turning circle within the rear of the buildings. Road widths and turning circles are proposed to be sufficient to facilitate access and operation of FRNSW specialist fire appliances having length of 12.5 m and width of 3 m. The proposed arrangement is proposed to achieve with *FRNSW Fire Safety Guidelines – Access for fire brigade vehicles and firefighters* Version 05 dated 4 October 2019 (Access Guidelines).

Furthermore, as per the Bushfire Assessment Report (250413B) Rev 6 dated 5 December 2025, the proposed access arrangement is understood to significantly exceeds the property access requirements within Section 7.4 of *Planning for Bush Fire Protection 2019* (PBP).

The size of fire compartments within buildings are not proposed to exceed the specified requirements of BCA Table C3D3. Therefore, no large isolated buildings are proposed to be constructed as part of the development and the proposed access provisions are expected to achieve compliance with the requirements of the BCA DtS Provisions. Fire compartment boundaries are proposed to be formed by construction (e.g. fire walls, floors, etc) in accordance with the definitions prescribed in the BCA and achieving FRLs as recommended within this report.

The site is within close proximity of multiple Fire Stations. Refer Table 6 for a list of surrounding fire stations.

*Table 6 – List of Surrounding Fire Stations.*

Fire Station	Address	Arrangement	Approximate Distance	Travel Time
FRNSW North Ryde Fire Station	120F Coxs Rd, North Ryde NSW 2113	Open 24 Hours Permanently Staffed	2.1 km	5 min (refer Figure 3)
FRNSW Willoughby Fire Station	53 Laurel St, Willoughby NSW 2068	Open 24 Hours Permanently Staffed	6.8 km	16 min (refer Figure 4)
FRNSW Lane Cove Fire Station	55 Dickson Ave, Artarmon NSW 2064	Open 24 Hours Permanently Staffed	7 km	10 min (refer Figure 5)
FRNSW Gordon Fire Station	966 Pacific Hwy, Gordon NSW 2072	Open 24 Hours Permanently Staffed	7.6 km	12 min (refer Figure 6)

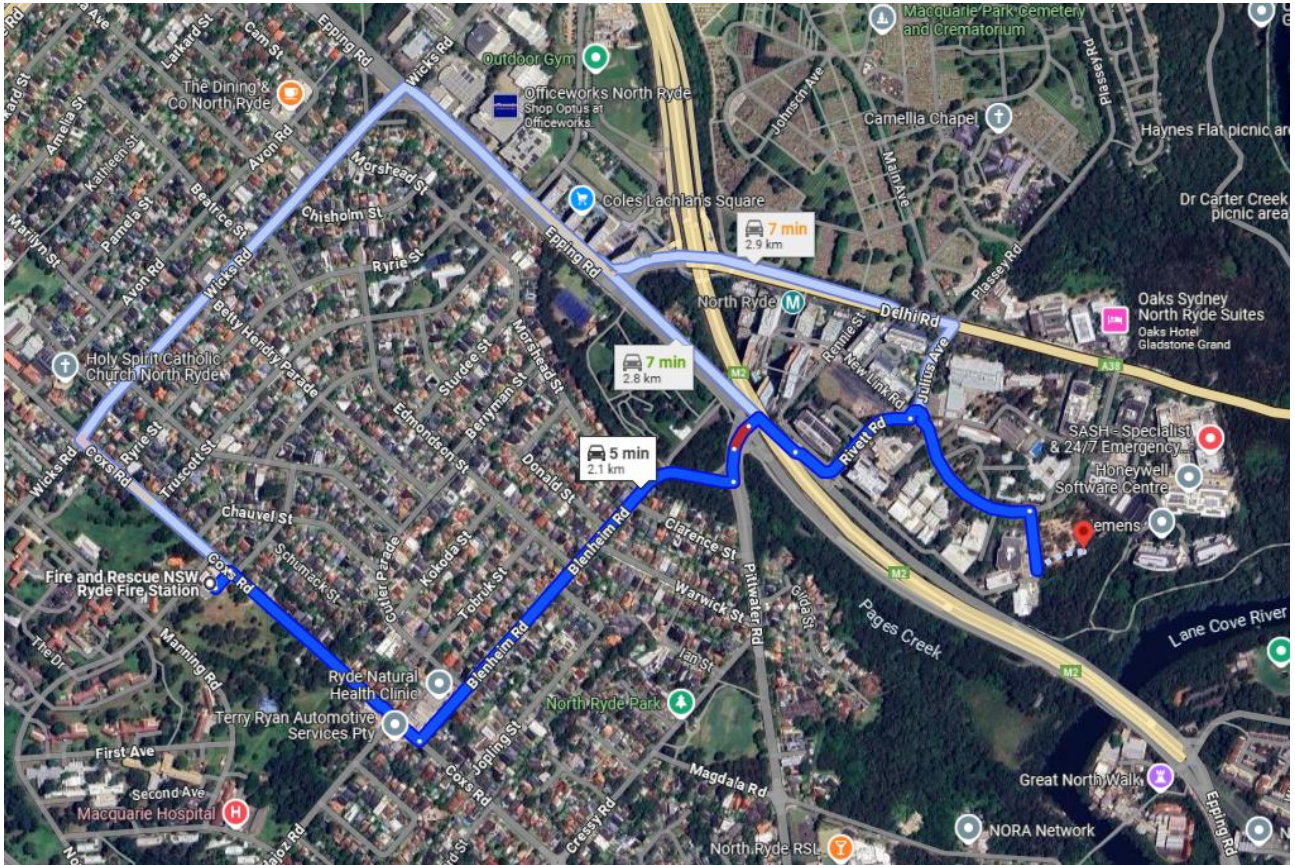

Figure 3 – Approximate Distance and Travel Time from Fire and Rescue NSW North Ryde Fire Station.

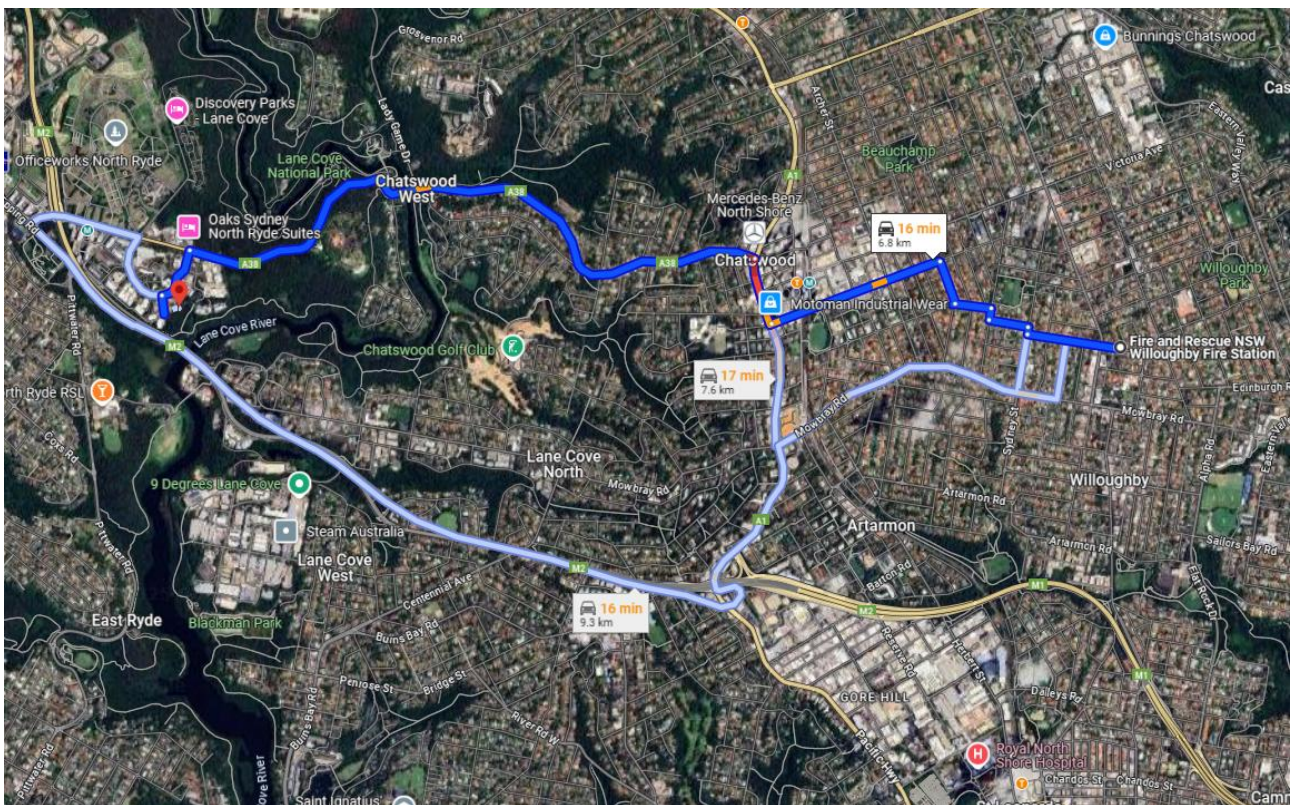

Figure 4 – Approximate Distance and Travel Time from Fire and Rescue NSW Willoughby Fire Station.

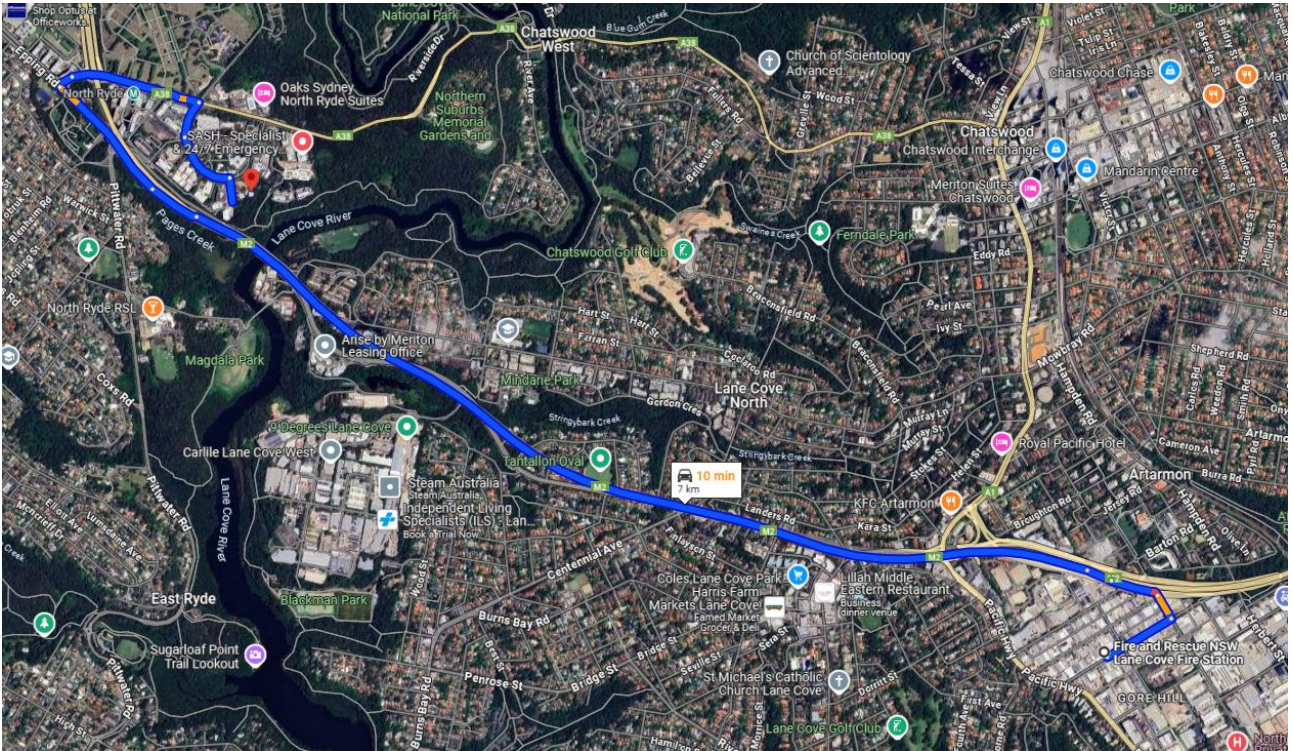

Figure 5 – Approximate Distance and Travel Time from Fire and Rescue NSW Lane Cove Fire Station.

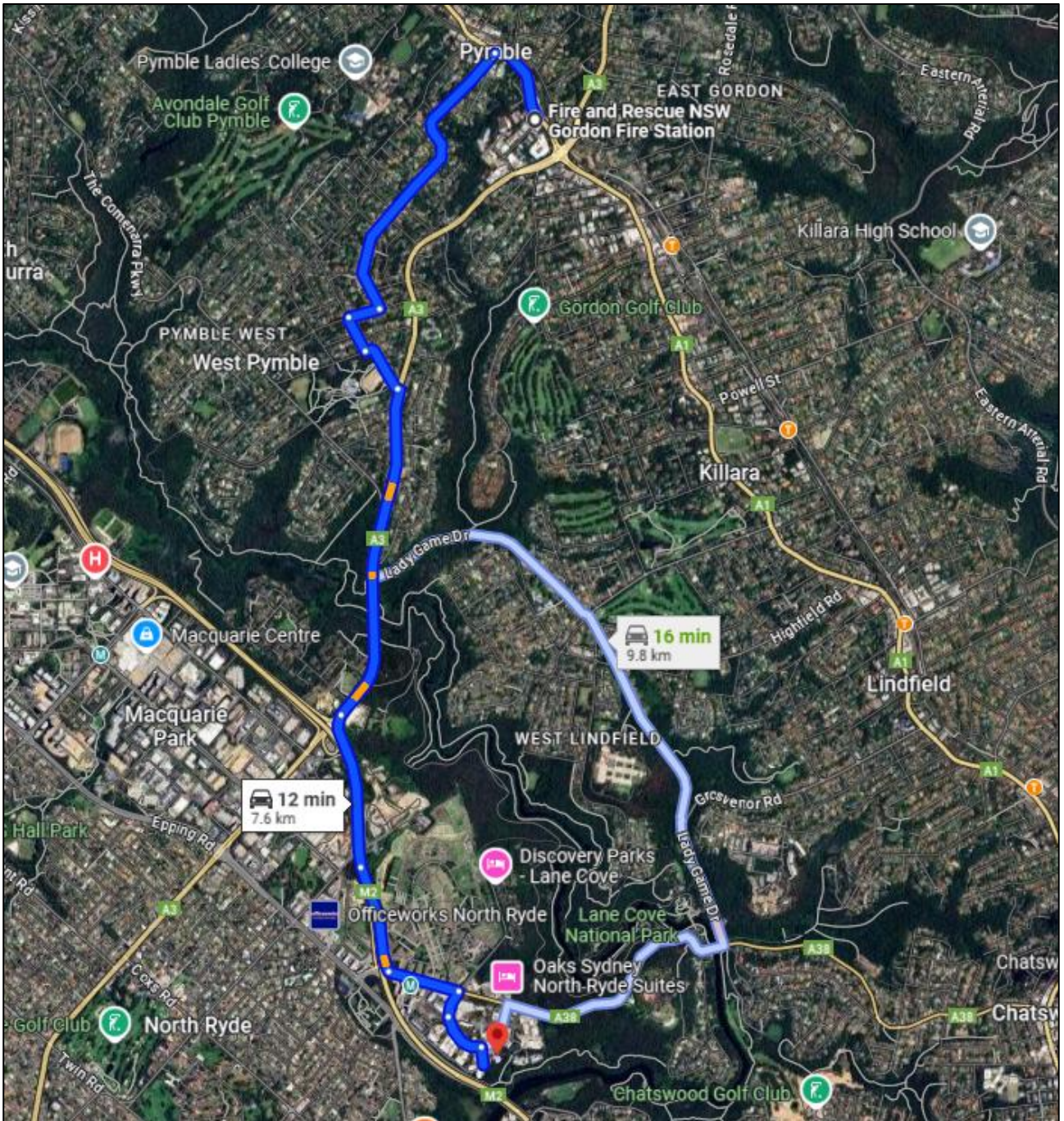

Figure 6 – Approximate Distance and Travel Time from Fire and Rescue NSW Gordon Fire Station.

## 2.2 BUILDING CHARACTERISTICS

The Julius Avenue Data Centre Development is proposed to operate 24/7 with limited occupancy outside of normal operation hours. The operating model of the Data Centre is yet to be determined (e.g., wholesale or hybrid).

Table 7 presents a summary of building uses and associated floor areas for the Data Centre Building and associated Generator Structure.

*Table 7 – Breakdown of Buildings by Storey and Use.*

Data Centre Building		
Storey	Classification	Use
Ground Floor	7a, 7b, and 8	Class 7a Carpark Area and Loading Dock Class 7b Plantroom and Storage. Class 8 HV Switchroom.
Level 1	7b	Class 7b areas including Data Halls, Mechanical Services Corridors, Circulation Corridors, Battery Rooms, Electrical Switchrooms, Storage Areas.
Level 2	5 and 7b	Class 5 office area and Class 7b areas including Data Halls, Mechanical Services Corridors, Circulation Corridors, Battery Rooms, and Electrical Switchrooms.
Level 3	5 and 7b	Same as Level 2.
Level 4	5 and 7b	Same as Level 2.
Level 5	7b	Lower Roof Level containing plant rooms.
Level 6	7b	Higher Roof Level containing open plant areas.
Generator Structure		
Storey	Classification	Use
Ground Floor	7b	Diesel storage
Level 1	7b	Generators Gantry
Level 2	7b	Generators Gantry
Level 3	7b	Generators Gantry
Level 4	7b	Generators Gantry

Table 8 presents a summary of key building characteristics for the proposed data centre building and associated external generator structure.

*Table 8 – Summary of Key Building Characteristics.*

<b>Data Centre Building</b>	
Characteristic	Value
Storeys Contained	7
Rise in Storeys	6
Occupancy Classifications	5, 7a, 7b, and 8
Type of Fire-Resisting Construction	A
Effective Height (Approximate)	35 m
Total Gross Floor Area (Approximate)	16,647 m <sup>2</sup>
Total Gross Building Area (Approximate)	40,236 m <sup>2</sup>
Floor Area of Largest Fire Compartment (Approximate)	3,710 m <sup>2</sup> (Level 5)
Height of Largest Fire Compartment (Approximate)	5 m
Volume of Largest Fire Compartment (Approximate)	18,550 m <sup>3</sup>
<b>External Generator Structure</b>	
Characteristic	Value
Number of Storeys Contained	5
Rise in Storeys	5
Occupancy Classifications	7b
Type of Fire-Resisting Construction	A
Effective Height (Approximate)	30 m
Total Building Floor Area (Approximate)	7,040 m <sup>2</sup>
Floor Area of Largest Fire Compartment (Approximate)	1,415 m <sup>2</sup>
Height of Largest Fire Compartment (Approximate)	6 m
Volume of Largest Fire Compartment (Approximate)	8,490 m <sup>3</sup>

## 2.3 DANGEROUS GOODS PRESENT ON SITE

The extent of dangerous goods proposed to be stored within the site is understood to be limited to the following:

- Diesel fuel stored within generator structures external to the building.
- Lithium-ion batteries generally stored within dedicated Battery Rooms and in Data Halls. Note, the storage areas are not expected to include batteries or other dangerous goods.

### 2.3.1 DIESEL FUEL ARRANGEMENT

There are total of 12 bulk storage diesel fuel storage tanks each with capacity of 75,000 L proposed to be located at the bottom level of generator structure. There are total of 48 generators (12 on Levels 1-4) each fitted with a day tank with expected capacity of 1,000 L. This results in overall expected diesel storage of 948 kL within the external generator structure.

It is understood that 7 kL of diesel fuel is expected to be present within the Data Centre Building serving the office generator (6 kL main tank and 1 kL day tank). Therefore, the overall diesel fuel stored on site is expected to be 955 kL.

### 2.3.2 LITHIUM-ION BATTERY ARRANGEMENT

Lithium-ion batteries are generally proposed to be provided within Battery Rooms and Data Halls. There are 12 off Battery Rooms proposed to be included per level within Level 1 to Level 4 of the building. This in total of 48 Battery Rooms within the building.

Refer to Figure 7 for an illustration of location of battery rooms containing lithium-ion battery energy storage system within a typical storey of the building containing Battery Rooms.

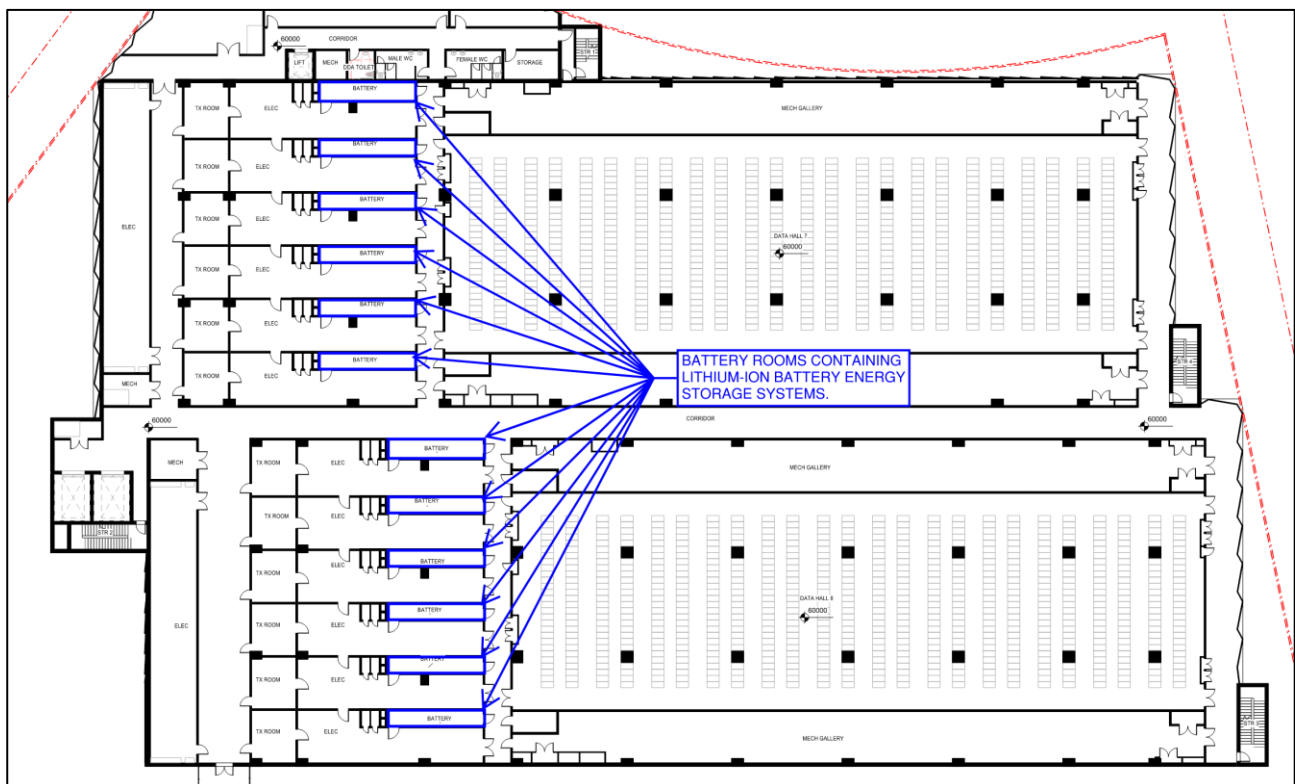

Figure 7 – Illustration of Location of Battery Rooms Containing Lithium-ion Battery Energy Storage System Within a Typical Storey of the Building Containing Battery Rooms.

## 2.4 DOMINANT OCCUPANT CHARACTERISTICS

Dominant occupant characteristics are based on the design occupant groups and are summarised in Table 9. These characteristics will influence the response of occupants in a fire scenario.

*Table 9 – Dominant Occupant Characteristics of Design Occupant Groups.*

Characteristic	Description
Distribution	Building occupants are expected to comprise of staff and infrequent escorted visitors and maintenance personnel. Children are not expected to be present.
State / Activity	The building is a place of employment and staff are expected to be conscious, awake, and sober. Occupants are expected to be alert and aware of their surroundings. Occupants in Data Halls and Plant Rooms are expected to be in a noisy environment. Occupants in other areas are not expected to be in a noisy or otherwise significantly distracting environment.
Physical attributes and level of assistance required	A minority of occupants may not be fully mobile and may require assistance evacuating. The majority of occupants are expected to be fully mobile, not require assistance when evacuating, and be able to provide assistance to others in an evacuation event.
Mental attributes	A minority may have difficulty recognising visual or audible alarm cues, understand evacuation instructions, evacuate in an orderly manner, or have the ability to make and implement decisions independently. The minority may require assistance evacuating. The majority of occupants are expected to recognise fire alarm cues, take instructions, and evacuate in an orderly and independent manner. The majority of occupants are expected to provide assistance to occupants who may not be able to independently respond to a fire scenario.
Level of assistance required / available	The level of assistance required by the minority of occupants to evacuate is expected to be limited. The building is generally expected to be fully occupied during working hours, and therefore adequate evacuation assistance is expected to be available where required.
Emergency training	Occupants are expected to be inducted and familiar with the emergency procedures. However, they are not expected to be trained in use fire suppression equipment. Staff are trained in the use of portable fire extinguishers in response to an event where pre-alarm thresholds are detected by an aspirating smoke detection system. Additionally, a basic level of response is expected, including an understanding of and response to emergency warning system tones, evacuation instructions, and exit signage.
Familiarity with the building	The building is the place of employment for the majority of occupants, who are therefore expected to be familiar with the building and paths of travel to exits. The minority of occupants who may not be familiar with the building are expected to follow the majority and therefore be able to evacuate in a similar manner.

### 3 PRELIMINARY FIRE SAFETY STRATEGY

The preventative and protective measures identified to address potential fire hazards form part of the Fire Safety Strategy proposed to demonstrate compliance with the BCA Performance. Items not specifically addressed in the Fire Safety Strategy are expected to comply with the DtS Provisions of the BCA.

The Preliminary Fire Safety Strategy will be subject to change as the design develops during future design phases.

All elements of the strategy shall be considered Essential Fire Safety Measures for the life of the building.

#### 3.1 FIRE RESISTANCE LEVELS

Building elements are generally proposed to comply with the fire compartmentation requirements of the BCA DtS Provisions for Type A fire-resisting construction. However, it is proposed to rationalise FRL requirements to a minimum of 120/120/120 for load bearing elements and -/120/120 for non-loadbearing elements in lieu of 240/240/240 and -/240/240, respectively.

All Battery Rooms are proposed to be fire separated from remainder of the building. It is proposed to adopt 4 hour FRL (240/240/240 for load-bearing elements and -/240/240 for non-load-bearing elements) for bounding construction (i.e., floors, walls, and slab above) of the Battery Rooms to adequately mitigate the risk of fire spread.

All Data halls are proposed to be fire separated from remainder of the building. It is proposed to adopt 2 hour FRL (120/120/120 for load-bearing elements and -/120/120 for non-load-bearing elements) for bounding construction (i.e., floors, walls, and slab above) of the Data Halls to adequately mitigate the risk of fire spread.

#### 3.2 FIRE COMPARTMENTATION

To increase occupant safety and to increase redundancy, the data centre buildings are proposed to be extensively fire compartmentalised with fire compartment sizes generally much lower than the limits of BCA DtS Provision C3D3. Fire compartmentation is generally configured as follows:

- Each storey shall be fire separated from other storeys.
- The following rooms within the building shall be fire compartmentalised from the remainder:
  - Circulation Corridors.
  - Combination of Mechanical Services Corridor(s) and Data Hall being served, grouped into a single compartment.
  - Battery Rooms.
  - Office areas.

#### 3.3 PROVISIONS FOR ESCAPE

Egress from the Data Centre building will be generally provided as follows:

- Multiple fire doors serving fire compartment boundaries are proposed to facilitate occupant egress throughout the building.
- Multiple building discharge points are available around the perimeter of the building to occupants egressing from Ground Floor, Level 1, and Level 2.
- Fire-isolated stairwells serve all floors of the building and also extend to the Roof Level.

Egress from the generator structure will be generally provided as follows:

- All levels are served via 2off dedicated fire-isolated stairs on the western and eastern sides of the generator structure that discharge at Ground Level.

Exit travel distances will be measured in accordance with the BCA DtS requirements and consideration of Security Zones, where an occupant cannot pass from a lower Security Zone to a higher Security Zone.

Exit travel distances are proposed to exceed the limitations prescribed in the BCA DtS Provisions with respect to maximum distance to an exit, maximum distance to a point of choice where at least two different exits are available, and the maximum distance between alternative exits.

Details of the exit travel distances are currently under review and are proposed to be addressed via Performance Solution. Plans depicting exit travel distances shall be provided as part of the PBDB.

### 3.4 FIRE HYDRANT SYSTEM

The building is to be served by a fire hydrant system supplied from combined fire hydrant and sprinkler water storage tank with capacity of 346 kL. The storage tank is proposed to be fed from a 150 mm connection to the 150 mm water main on Julius Avenue. The combined fire hydrant and fire sprinkler system are served by 2off electric booster pump and an electric jockey pump.

Fire hydrant coverage is proposed to be provided with a combination of internal and external fire hydrant outlets, generally located within fire-isolated stairways and adjacent external building access points, respectively. Additional fire hydrants shall be provided within Circulation Corridors as required to facilitate coverage.

The building volume exceeds 108,000 m<sup>3</sup> and therefore considered outside of the scope of AS 2419.1:2021 and must be the subject of a Performance Solution.

The fire hydrant system is generally proposed to comply with the requirements of AS 2419.1:2021 (despite volume exceeding 108,000 m<sup>3</sup>), with the exception of the following:

- Coverage from internal fire hydrant outlets is proposed to be achieved through 2 hose lengths (60 m hose + 10 m spray) in lieu of 1 hose length (30 m hose + 10 m spray).
- Coverage from 'additional' internal fire hydrants outside of fire-isolated stairs permitted to cross fire compartment boundaries.

Signage shall be located at the site fire brigade booster assembly, Fire Control Centre, FDCIEs, and at each fire hydrant to identify areas of the building require additional hose lengths. The signage shall be a permanent, fade resistant and weatherproof sign and utilise capital lettering with a height not less than 25 mm and in a colour contrasting the background. Signage shall state "*ADDITIONAL LENGTH OF FIRE FIGHTING HOSE IS REQUIRED TO REACH ALL AREAS FROM INTERNAL AND EXTERNAL HYDRANTS*" or equivalent.

### 3.5 AUTOMATIC FIRE SUPPRESSION SYSTEMS

An automatic fire sprinkler system is proposed to serve the building, supplied from combined fire hydrant and sprinkler water storage tank with capacity of 346 kL. The storage tank is fed from the 150 mm connection to the 150 mm water main on Julius Avenue. The combined fire hydrant and fire sprinkler system are served by 2off electric booster pump and an electric jockey pump.

A fire brigade booster assembly serving the combined system is proposed to be provided comprising 8off feed fire hydrants connected to site water main, and 8off inlets. A hard tank suction may also be provided to facilitate enhanced boosting capability.

The buildings are proposed to be served by automatic fire sprinkler systems generally complying with AS 2118.1:2017, FMDS 5-32, FMDS 5-33, and BCA Specification 17 with the exception of the following:

- Sprinkler Valve Rooms will not have direct egress to a road or open space. These will be subject to a Performance Solution demonstrating attending fire brigade personnel can safely access these rooms.
- Tail-end pre-action sprinkler system proposed to exceed the area limitations presented in AS 2118.1:2017.

Data Halls, Mechanical Services Corridors, and Electrical Rooms are proposed to be provided with pre-action automatic fire sprinkler suppression due to the risk of water damage to equipment that might result from damaged automatic sprinklers or piping. Pre-action automatic fire sprinkler protection shall extend to both above and below ceiling areas. Pre-action sprinkler systems shall be configured such that the control valve shall open and charge the system with water only in the event of both sprinkler head and smoke detector activation.

Conventional wet type automatic fire sprinkler protection is proposed to serve the following areas:

- Office areas.
- Storage areas.
- Front of house areas.
- Circulation Corridors.
- Carpark and Loading Dock
- Sprinkler Valve Room.

Fast response sprinkler heads with an activation temperature of 68°C shall be utilised throughout the building, except the activation temperature may be increased for areas of high ambient temperature in accordance with AS 2118.1:2017 and/or FMDS 5-32 and 5-33.

Fire water storage tanks shall be provided in accordance with AS 2419.1:2021 and AS 2118.1:2017. Infill from the Utility Water Main may also be provided to facilitate enhanced firefighting provisions to address (in part) the special hazards associated with this site.

### 3.6 PORTABLE FIRE EXTINGUISHERS

Portable fire extinguishers are proposed to be provided throughout in accordance with AS 2444:2001. Additional portable fire extinguishers are proposed to be provided in lieu of the provision of a fire hose reel system.

All areas of the building shall be located within 15 m of a 4.5 kg dry chemical ABE type portable fire extinguisher, or a 5 kg carbon dioxide type portable fire extinguisher. Foam based extinguishers shall be located within rooms where diesel fuel is stored. Fire blankets shall serve locations equipped with cooking facilities as required in office areas.

### 3.7 FIRE CONTROL CENTRE

A Fire Control Centre in accordance with BCA Specification 19 is proposed to be provided. The Fire Control Centre shall contain the main fire detection control and indicating equipment (FDCIE, i.e. fire panel), details of the building and drawings to support fire brigade operations for the Julius Avenue Data Centre site, including an Emergency Services Information Package (ESIP).

Additional signage shall be provided at the Fire Control Centre to notify the fire brigade of the following:

- Presence of battery ESS. Signage shall be installed stating: “LITHIUM-ION BATTERY ENERGY STORAGE SYSTEMS PRESENT WITHIN DATA CENTRE BUILDINGS”. The signage shall utilise capital lettering, not less than 50 mm, in a colour contrasting the background. Plans reflecting the location and capacity of the battery ESS shall be included in the Fire Control Centre.
- Requirement for the attending fire brigade to utilise additional hose lengths for adequate fire hydrant system coverage (refer Section 3.4).
- Requirement for firefighters to wait for power isolation prior to undertaking firefighting activities. Signage shall be installed stating: “FIRE BRIGADE TO WAIT FOR LOCALISED POWER ISOLATION PRIOR TO UNDERTAKING FIREFIGHTING ACTIVITIES”. The signage shall utilise capital lettering, not less than 50 mm, in a colour contrasting the background. Plans reflecting the location of doors containing firebolts shall be included in the Fire Control Centre.

### 3.8 AUTOMATIC FIRE DETECTION AND ALARM SYSTEM

An addressable monitored automatic fire detection and alarm system provided with an Alarm Signalling Equipment is proposed to be provided throughout each building in accordance with AS 1670.1:2018.

All areas of the building required to be provided with fire detectors in accordance with AS 1670.1:2018 shall be served by multi-point aspirating smoke detection systems generally complying with AS 1670.1:2018.

All aspirating smoke detection systems installed within areas of high airflow shall be designed in accordance with technical design documents prepared by the system manufacturer associated with areas of high airflow.

An emergency warning and intercom system (EWIS) in accordance with AS 1670.4:2018 is not proposed to be provided. Instead, an occupant warning system (OWS) shall be provided throughout the building in accordance with AS 1670.1:2018. Visual Alarm devices shall be provided where ambient sound pressure levels exceed the thresholds prescribed in Clause 3.22.4 of AS 1670.1:2018.

Activation of the fire detection system shall result in the following:

- Notification to the fire brigade.
- Emergency warning system activation.
- Signal to the building management systems, access control system, security systems and the like.
- Automatic shutdown of air handling systems required to shutdown in accordance with the BCA DtS Provisions / AS 1668.1:2015.

### 3.9 AIR HANDLING SYSTEMS

All air handling systems shall comply with the requirements of the BCA DtS Provisions with the exception of the following:

- Stair pressurisation system is not proposed to be provided within the building.
- Zone pressurisation system is not proposed to be provided within the building.

Data Halls are also proposed to be served by self-contained air handling systems (units located inside the Data Hall compartment that do not promote spread of smoke to other compartments) that are active at all times and continue to operate in general alarm. Smoke and/or fire dampers are provided as required by BCA DtS Provisions and applicable referenced standards.

Considering some of the air handling systems that only cycle air within a fire compartment (do not promote the spread of smoke between compartments) are proposed to run in fire mode, manual isolation shall be available for occupant or fire brigade use as required.

It is noted that an off-gas ventilation system is proposed for the Battery Rooms (refer Section 3.11).

Details of air handling systems serving the building and their intended operation in normal conditions and fire-mode is currently under review and shall be clarified as part of the PBDB.

### **3.10 OFF GAS DETECTION AND ALARM SYSTEM**

Battery Rooms containing lithium-ion batteries forming part of a battery ESS shall be protected by gas monitoring systems to monitor for the build up toxic and flammable gasses. The system shall include gas monitoring detection sensors capable of detecting battery off-gases (e.g. hydrogen gas) located within each room containing lithium-ion batteries.

The proposed gas monitoring system shall incorporate control panels located outside the room being monitored, allowing for occupants or the fire brigade to be provided with information associated with the environment within the room without needing to enter the room. Each control panel shall incorporate visual status LED indicators to advise whether the gas concentration is within normal range, exceeding normal range, or the equipment is in fault state.

Configuration and interfaces of off-gas detection (e.g. connected to BMS and/or Fire Detection and Alarm System) is currently under review and shall be clarified as part of the PBDB.

### **3.11 OFF GAS VENTILATION SYSTEM**

Battery Rooms containing lithium-ion batteries forming part of a battery ESS are proposed to be provided with a mechanical exhaust system to prevent the build-up of off gasses. Each Battery Room shall be served by an exhaust system with a minimum exhaust rate of 12.5 L/s per m<sup>2</sup> floor area of the room in accordance with FMDS 5-33. The off-gas ventilation system shall be activated in an event of:

- Activation of the off-gas detection system. The off-gas detection system shall be designed to activate when the level of off-gas within the Battery Room exceeds 25% of the Lower Flammability Limit (LFL).
- In an event of fire detected within the Battery Room (i.e. an event of general alarm initiated from the Battery Room).

The off-gas exhaust system is proposed to be provided with a dedicated fire rated ventilation shafts which are required to operate for emergency ventilation during a fire scenario.

The detail of the system operation and its components are currently under review and shall be clarified as part of the PBDB.

### **3.12 EXIT AND EMERGENCY LIGHTING**

Exit and emergency lighting shall be provided throughout in accordance with BCA DtS Provisions E4D2 - E4D8 and AS/NZS 2293.1:2018.

### 3.13 DIESEL FUEL GENERATORS

The diesel fuel arrangement is proposed to comply with the requirements of AS 1940:2017. Key AS 1940:2017 compliance items are as follows:

- Diesel tank construction and ventilation.
- Tank fill points.
- Location and spacing of diesel fuel storage tanks.
- Separation to buildings, boundary, and other protected places.
- Structural and fire resistance requirements of the generator supporting structure.
- Fire protection requirements.
- General safety requirements.

#### 3.13.1 TANK CONSTRUCTION AND VENTILATION

The diesel fuel tanks are in the form of self-bunded 'belly tanks' mounted to the base of the diesel generator engine skid. The tank shall be designed to comply with the construction and ventilation requirements of AS 1657:2018, AS 1692:2006, and AS 1940:2017. Therefore, this assessment does not focus on specific elements associated with the tank construction and provide the design requirements to facilitate installation on site.

#### 3.13.2 TANK FILL POINT

Section 5.3 of AS 1940:2017 provides the requirements for fill connections on storage tanks that are filled from a tank vehicle. In accordance with Clause 5.3.2, the following provisions shall be satisfied for the proposed diesel fuel arrangement:

- The fill point shall be readily accessible.
- The fill point shall be protected from accidental damage.
- The fill point for a tank containing combustible liquid shall be located outside where possible.
- The fill point shall be located such that the tank vehicle is not required to enter the tank compound to make the fuel delivery.
- The fill point shall be clearly identified.
- The areas around the tank fill point and vehicle hose connection point shall be impervious to the product.

Clause 5.3.3 of AS 1940:2017 outlines the requirements for tank liquid level indication.

#### 3.13.3 LOCATION AND SEPARATION REQUIREMENTS

Section 5.7 of AS 1940:2017 outlines the requirements for the separation of above-ground fuel storage tanks. Table 5.3 of AS 1940:2017 specifies the requirements for separation between fuel storage tanks, distances to security fence, and on-site protected places (buildings inside or outside the property boundary). Table 5.4 of AS 1940:2017 specifies the requirements for distances to off-site protected places based on the total volume of stored fuel. An assessment of the proposed diesel fuel storage arrangement with respect to location and separation requirements of AS 1940:2017 has been undertaken to confirm compliance, with the results summarised in Table 10.

Table 10 – Assessment of AS 1940:2017 Location and Separation Requirements.

AS 1940:2017 Requirements	Proposed Arrangement	Assessment Results
Table 5.3 requires a separation distance to other platforms or package storage to be at least 7.5 m.	No other platforms or package storage within vicinity of generator area.	Proposed arrangement meets the requirements of AS 1940:2017.
Table 5.3 requires distances to protected places that are considered 'office buildings, warehouses, manufacturing and processing areas, workshops or amenities blocks on the same premises' to be calculated based on Table 5.4 but not exceed 7.5 m. Considering 75 kL of diesel per bulk storage tank, Table 5.4 requires minimum distance of approximately 6.2 m.	Diesel storage tanks are proposed to be located more than 8 m from the building external wall.	Proposed arrangement meets the separation requirements of AS 1940:2017.
Table 5.3 requires distance to security fence to be diameter of the tank or 7.5 m, whichever is less, but at least 3 m.	Greater than 7.5 m (approximately 26 m) to security fence on allotment boundary.	Proposed arrangement meets the requirements of AS 1940:2017.
Considering the tanks as horizontal tanks, Clause 5.7.6 of AS 1940:2017 requires a minimum 0.6 m distance between tanks. Considering the tanks are double walled and have integral secondary containment, a spacing of 0.6 m between tanks is also required by Clause 5.9.2 (h) of AS 1940:2017.	Approximately 2.5 m distance between diesel storage tanks.	The distance between tanks meets the requirements of AS 1940:2017.
Table 5.4 requires the distance to off-site protected places to be at least 6.2 m.	Greater than 7.5 m (approximately 35 m) to security fence on allotment boundary.	Proposed arrangement meets the requirements of AS 1940:2017.

### 3.13.4 BUNDS AND COMPOUNDS

Section 5.8.1 of AS 1940:2017 requires storage tanks to be provided with adequate bunding compound or have integral secondary containment complying with Clause 5.9 of AS 1940:2017.

It is understood that tanks are proposed to have integral secondary containment in accordance with AS 1940:2017, not requiring the provision of a tank bunding compound.

### 3.13.5 SUPPORTING STRUCTURE

In order to comply with Clause 5.11.2 of AS 1940:2017, any supporting structure between the foundation and the tank shall comply with the following requirements:

- Any supporting structure, or ancillary structure used to provide rigidity, shall be made wholly of non-combustible material.
- Any metallic support that is more than 1 m high and supports a tank having a capacity greater than 10,000 L of combustible liquid, shall be protected by material having an FRL of at least 120/120/120. If metallic supports are proposed, they shall achieve 2hr FRL under AS 1940:2017, as 48,000 L of diesel fuel is expected to be supported (1000 L day tank for each generator).
- The structure shall be designed according to the requirements of the Australian Standard applicable to the particular construction (e.g. AS 4100:2020 for steel and AS 3600:2018 for concrete).
- The design shall take account of the total mass of the tank when full of either water or product, whichever is the greater, any wind loading, any possible uplift loading on restraining connections, and any likely seismic loading (refer to AS 1170.4:2007). Any such anchorage shall be designed to overcome the maximum anticipated buoyancy force.

### 3.13.6 FIRE SERVICES AND EQUIPMENT

Section 11 of AS 1940:2017 sets out the minimum requirements for fire protection system. Section 11.3 describes the general requirements for fire protection equipment and states that tanks within the boundary of a single property may be treated as separate storages for the purpose of determining total fire protection requirements, provided that all parts of the total storage are physically separated from each other by at least the distance given in Table 5.4. Table 5.4 requires 6.2 m separation distance. Considering separation distance of approximately 2.5 m, the tanks are treated as a group of tanks in accordance with requirements of Section 11.3.

Considering the aggregate capacity of diesel storage tanks within the generator compound is 955,000 L, Section 11.12 of AS 1940:2017 is utilised to set the minimum fire protection requirements as this Section outlines the minimum fire protection requirements for above-ground tank storage of aggregate capacity of 60 m<sup>3</sup> to 2000 m<sup>3</sup>. To satisfy compliance with this section, the following measures shall be provided:

- A fire hose reel and foam-making equipment.
- At least two powder-type portable fire extinguishers where the travel distance to any fire extinguisher does not exceed 15 m.

It is recommended to pursue the use of power-type portable fire extinguishers, avoiding the requirement for firefighting foam. It is recommended 9 kg powder type portable fire extinguishers having a rating of 2A 60B(E) are provided to serve the generators in accordance with AS/NZ 1841.5:2007, AS 4265:1995, AS 1850:2009, and AS 2444:2001 as applicable.

Please note, the above measures are the minimum requirements solely to address AS 1940:2017 compliance. Other fire services and equipment in addition to the above may be considered required by the BCA (subject to BCA assessment) and Fire Safety Study (to mitigate the risks identified). Other protective and preventive measures for the generator structure are currently under review and shall be clarified as part of the PBDB.

### 3.14 LITHIUM-ION BATTERY ENERGY STORAGE SYSTEMS

The proposed development incorporates lithium-ion battery ESS, with the majority of batteries being confined to battery racks in Battery Rooms. However, decentralised systems are also proposed to be implemented within Data Halls.

The special hazards presented by lithium-ion battery ESS are proposed to be addressed through fire compartmentation, use of tested and certified battery systems, active fire protection, off gas detection, and ventilation.

#### 3.14.1 BATTERY ROOMS

The detail of the batteries, including testing data, inherent safety measures, arrangement, and quantities are currently under review. Plans depicting this information shall be provided as part of the PBDB.

All battery systems within Battery Rooms are proposed to comply with requirements of FMDS 5-33.

#### 3.14.2 DATA HALLS

Provision of lithium-ion battery backup units within server racks may be proposed in Data Halls. These battery backup units are installed to provide a localised uninterruptible power supply in the event of mains power failure. Lithium-ion battery backup units within server racks are proposed to be installed in accordance with the requirements of FMDS 5-32.

Battery management systems shall be configured to alert onsite staff of battery voltage, temperature, or current fluctuations outside of normal operating conditions.

Lithium-ion battery backup units within server racks shall be installed in accordance with the requirements of FMDS 5-32 and provided with the following:

- Lithium-ion batteries comply with requirements of UL1642.
- Lithium-ion batteries comply with requirements of UL1973.
- Lithium-ion batteries comply with requirements of AS/IEC 62619.
- Maximum power capacity of 20 kWh per server rack as a distributed power configuration.
- No more than two shelves containing battery backup unit modules shall be located together in the same area of the rack as illustrated in Figure 8.
- Aisle spacing between server rows shall be at least 1.2 m.
- Vertical barriers comprising minimum 20-gauge (0.9 mm) solid sheet metal shall be provided on the side of every third server rack to limit the fire spread as illustrated in Figure 9. Vertical barriers shall be provided throughout any server rack row where lithium-ion battery backup units are installed or expected to be installed in the future.
- Enhanced fire sprinkler protection design criteria as per FMDS 5-32.

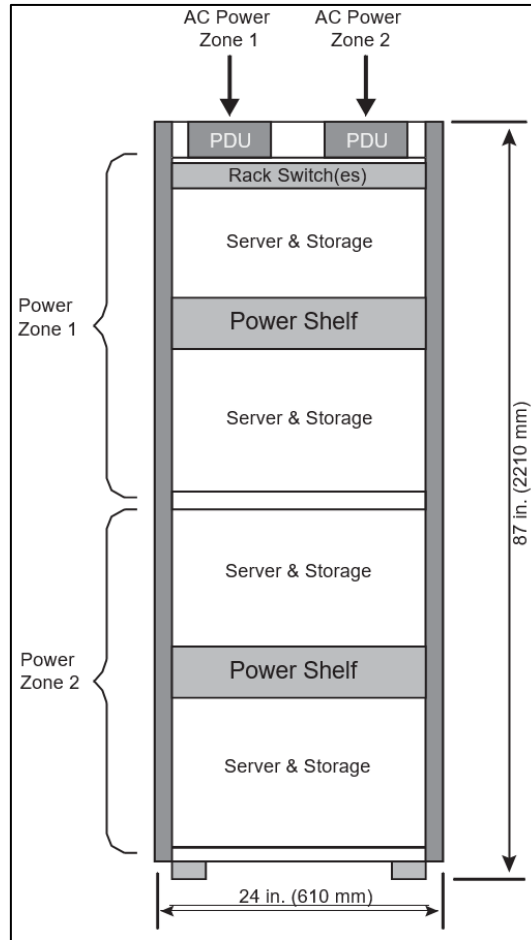

Figure 8 – Extract from FMDS 5-32 – Illustration of Lithium-ion Battery Backup Units in a Server Rack.

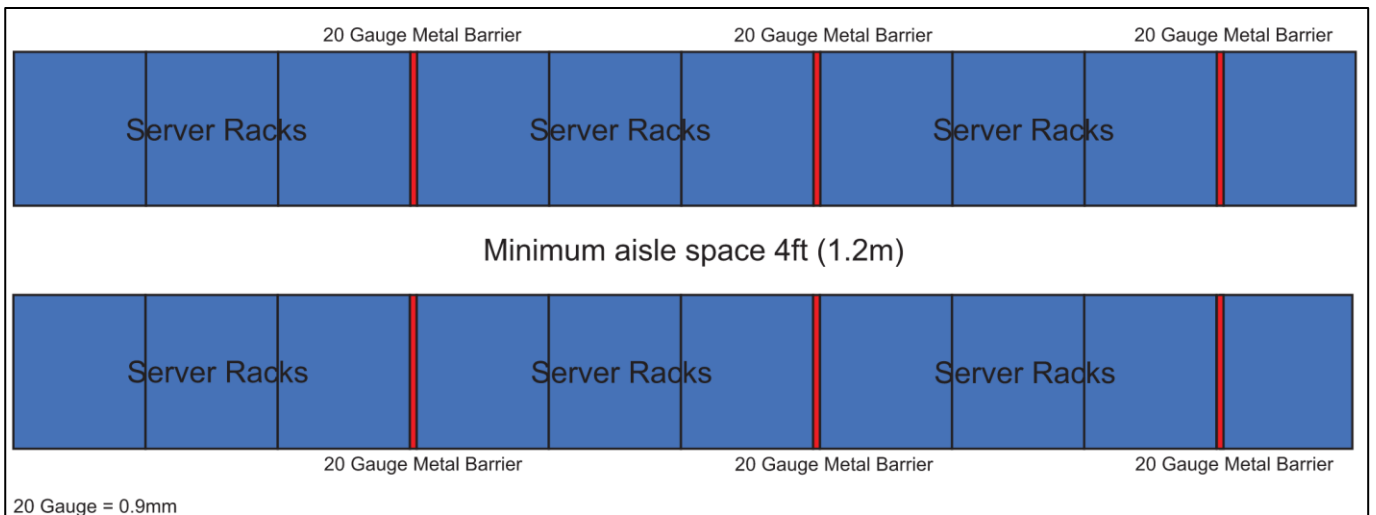

Figure 9 – Extract from FMDS 5-32 – Illustration of Server Rack Vertical Barriers.

### 3.15 EV AND EV CHARGING

The detail of EV and EV charging is currently under review and shall be clarified as part of the PBDB.

It is proposed to adopt requirements of AFAC Position Statement on EVs and EV charging equipment in the built environment (Doctrine ID 3098 Version 1 dated 20 December 2022) which is endorsed by FRNSW.

The EV charging stations be protected by bollards to protect against vehicular damage.

The EV charging stations shall be interfaced with a remote emergency shutdown facility. The emergency shutdown facility to be located at the building entrance and/or adjacent the fire panel.

EVs with mechanical damage shall not be permitted within the site.

All EV charging stations shall be provided with blue “EV” stickers or badges on number plates to indicate that it is an EV or hybrid vehicle as per FRNSW recommendations.

Block plans identifying the location of the EV charging station and the master isolation switch to be located at the Fire Control Centre.

### 3.16 STANDARDS OF CONSTRUCTION AND COMMISSIONING

Essential Safety Measures shall be installed, tested, and commissioned in accordance with the Australian Standards applicable to the installed Essential Safety Measures and this Fire Safety Strategy. Commissioning tests required to be undertaken include but are not limited to:

- Confirmation of operation of all installed fire detectors and subsequent activation of the occupant warning system and other systems required to operate / shutdown in fire mode.
- Testing of all fire dampers, air conditioning shutdowns or controls required in order to achieve the building fire mode operational requirements.
- Testing of signals to building management system, access control system, security systems and the like.
- Testing of fire alarm transmission signal to the local fire authority or monitoring facility.
- Sound pressure level testing of the occupant warning system.
- Flow and pressure testing of the fire hydrant and fire sprinkler systems.
- Hydrostatic pressure testing of the fire hydrant and fire sprinkler systems.
- Exit and emergency lighting discharge testing.
- Testing of gas monitoring and ventilation systems serving rooms containing lithium-ion batteries.

Records of testing and commissioning activities shall be included in Operation and Maintenance Manuals, forming part of the baseline documentation package for the building.

### 3.17 STANDARDS OF MANAGEMENT, USE AND MAINTENANCE

The Fire Safety Strategy extends for the life of the buildings, and it is the responsibility of the building owner to ensure fire safety management and maintenance tasks are being undertaken in accordance with this Fire Safety Strategy.

The following fire safety management and emergency response strategies shall be implemented:

- All occupants shall undertake an induction process which identifies all relevant exit locations and advises on emergency response procedures.
- A hazardous goods register shall be established and maintained by building management.
- A register of doorsets required to comprise of fire resisting elements shall be kept onsite and verified during annual maintenance activities.
- The building owner shall prepare and follow management procedures to conduct reviews of the storage of goods and general housekeeping to maintain a reasonable fire load within the building and ensure egress paths and access to Fire Services equipment are maintained.
- Work permits and safe work method statements are required for any works conducted onsite. A management system shall be developed and implemented for the management of hot work (e.g. welding).

- Electrical systems, equipment and plant shall be regularly inspected and maintained in accordance with regulatory requirements, in intervals not exceeding 1 year.

Emergency response procedures shall be developed to facilitate the following general fire emergency response strategy for the buildings:

- In the event of a confirmed fire incident, early occupant fire suppression via the use of portable fire extinguishers shall be undertaken if deemed appropriate.
- The local fire brigade shall be notified automatically through the automatic fire detection and alarm system to facilitate prompt intervention.
- Fire brigade intervention shall only occur if a threat to life safety is introduced as a result of a fire event and shall commence only after an emergency shutdown procedure of electrical plant has occurred. If the fire risk is life-threatening (as deemed by attending firefighters), the building occupants are expected to undertake an emergency shutdown procedure prior to fire brigade search and rescue commencement. The shutdown procedure shall include shutdown to all electrical supply to the room required to be electrically isolated to facilitate fire brigade intervention.
- On duty site security personnel shall open all security access gates when appropriate to facilitate fire brigade perimeter access to the buildings.
- Should doors providing access to secure areas within the Data Centre facility be provided with a mechanical locking provision, Onsite Security shall ensure keys to mechanical locking are made available to the attending fire brigade.

Maintenance of all Essential Fire Safety Measures shall be undertaken in accordance with relevant Legislation. All systems that fall within the scope of AS 1851:2012 shall be tested and maintained in accordance with the requirements of AS 1851:2012.

The exit and emergency lighting system shall be tested and maintained in accordance with AS/NZS 2293.2:2019. Maintenance records shall be kept up to date and located onsite.

FRNSW shall be notified of all planned activities requiring isolation of active Essential Fire Safety Measures.