



215, 229-239 Pitt St, Merrylands NSW
Mixed-Use Development

OPERATIONAL WASTE MANAGEMENT PLAN

8/10/2025
Report No. 6071
Revision E

Client

Anglicare

<https://www.anglicare.org.au/>

Architect

Fuse Architects

<https://www.fusearchitects.co.uk/>

REVISION REFERENCE

Revision	Date	Prepared by	Reviewed by	Description
A	18/03/2025	S. Dib	H. Wilkes	Draft
B	14/07/2025	H Wilkes	J Parker	Amendment
C	18/07/2025	H Wilkes	J Parker	Amendment
D	18/08/2025	H Wilkes	J Parker	Final
E	8/10/2025	H Wilkes	J Parker	Amendment

The information contained in this document produced by Elephants Foot Consulting (EFC) is solely for the use of the client identified on the cover sheet for the purpose for which it has been prepared for. EFC undertakes no duty, nor accepts any responsibility for any third party who may rely upon this document. Reproduction, publication or distribution of this document without written permission from EFC is strictly prohibited.

TABLE OF CONTENTS

1.0	ACKNOWLEDGEMENT OF COUNTRY	3
2.0	INTRODUCTION.....	3
2.1	SCOPE OF REPORT	3
2.2	REPORT CONDITIONS	4
3.0	LEGISLATION & GUIDANCE.....	5
4.0	DEVELOPMENT OVERVIEW.....	6
4.1	SITE LOCATION.....	6
5.0	RESIDENTIAL WASTE MANAGEMENT	7
5.1	RESIDENTIAL WASTE GENERATION ESTIMATES.....	7
5.2	RESIDENTIAL BIN SUMMARY	8
5.3	RESIDENTIAL CHUTE DISCHARGE EQUIPMENT SUMMARY	8
5.4	RESIDENTIAL WASTE DISPOSAL PROCEDURES.....	8
5.4.1	RESIDENTIAL GENERAL WASTE AND RECYCLING DISPOSAL PROCEDURES	9
5.4.2	RESIDENTIAL FOGO DISPOSAL PROCEDURES	9
5.5	RESIDENTIAL BIN COLLECTION PROCEDURES	10
5.6	OTHER RESIDENTIAL WASTE MANAGEMENT CONSIDERATIONS	10
5.6.1	RESIDENTIAL COMMON AREAS.....	10
5.6.2	LANDSCAPED AREAS AND GARDEN ORGANICS.....	10
5.6.3	RESIDENTIAL BULKY WASTE PROCEDURES.....	11
6.0	COMMERCIAL AND RETAIL WASTE MANAGEMENT	12
6.1	COMMERCIAL AND RETAIL WASTE GENERATION ESTIMATES.....	12
6.2	COMMERCIAL AND RETAIL BIN SUMMARY	13
6.3	COMMERCIAL AND RETAIL WASTE DISPOSAL PROCEDURES.....	13
6.4	COMMERCIAL AND RETAIL WASTE COLLECTION PROCEDURES.....	13
6.5	OTHER COMMERCIAL AND RETAIL WASTE MANAGEMENT CONSIDERATIONS..	14
6.5.1	WASHROOM FACILITIES.....	14
6.5.2	PRINTING & PHOTOCOPYING ROOMS	14
6.5.3	LIQUID WASTE	14
6.5.4	PROBLEM WASTE.....	14
7.0	STAKEHOLDER ROLES & RESPONSIBILITIES	15
8.0	SOURCE SEPARATION.....	16
9.0	EDUCATION	17
9.1	SIGNAGE.....	17
10.0	POLLUTION PREVENTION.....	18
11.0	BIN WASHING.....	18
12.0	BIN MOVING PATHS.....	18
13.0	EQUIPMENT SUMMARY	19

14.0	WASTE ROOMS	19
15.0	CONSTRUCTION REQUIREMENTS.....	21
15.1	ADDITIONAL CONSIDERATIONS.....	21
16.0	USEFUL CONTACTS.....	22
APPENDIX A:	ARCHITECTURAL PLANS.....	23
APPENDIX: A.1	GROUND FLOOR PLAN – WASTE AREAS AND COLLECTION POINT	24
APPENDIX: A.2	GROUND FLOOR PLAN MEZZANINE – WASTE AREAS.....	25
APPENDIX: A.3	BASEMENT LEVEL 3 – BULKY WASTE ROOM	26
APPENDIX B:	INSTALLATION EQUIPMENT	27
APPENDIX: B.1	TYPICAL DUAL CHUTE SHAFT & PENETRATION LAYOUT	28
APPENDIX: B.2	EXAMPLE RESIDENTIAL LEVEL RECYCLING BIN LAYOUT	29
APPENDIX: B.3	EXAMPLE CAROUSEL SYSTEM FOR 1100L BINS	30
APPENDIX: B.4	TYPICAL LINEAR TRACK SYSTEM FOR 1100L BINS	32
APPENDIX C:	PRIMARY WASTE MANAGEMENT PROVISIONS.....	34
APPENDIX: C.1	TYPICAL BIN SPECIFICATIONS.....	35
APPENDIX: C.2	SIGNAGE FOR WASTE AND RECYCLING BINS.....	36
APPENDIX: C.3	EXAMPLE COLLECTION VEHICLE INFORMATION.....	38
APPENDIX D:	SECONDARY WASTE MANAGEMENT PROVISIONS.....	40
APPENDIX: D.1	EXAMPLE HANDHELD BIN MOVERS	41
APPENDIX: D.2	EXAMPLE SEATED BIN MOVERS	42
APPENDIX: D.3	EXAMPLE BIN TRAILERS	43
APPENDIX: D.4	EXAMPLE BIN TOWING ATTACHMENTS	45
APPENDIX: D.5	EXAMPLE BIN LIFTER FOR 240L BINS.....	46
APPENDIX: D.6	EXAMPLE SOURCE SEPARATION RECEPTACLES	47

TABLE OF FIGURES

Figure 1: Site Location.....	6
------------------------------	---

LIST OF TABLES

Table 1: Estimated Waste and Recycling Volumes – Residential.....	7
Table 2: Estimated FOGO Volumes – Residential.....	7
Table 3: Chute Discharge Equipment Summary – General Waste.....	8
Table 4: Chute Discharge Equipment Summary – Recycling	8
Table 5: Estimated Waste and Recycling Volumes – Commercial and Retail	12
Table 6: Stakeholder Roles and Responsibilities	15
Table 7: Operational Waste Streams.....	16
Table 8: Equipment Summary.....	19
Table 9: Waste Room Areas.....	19
Table 10: Waste Room Requirements.....	20

GLOSSARY OF ABBREVIATIONS AND TERMS

TERM	DESCRIPTION
<i>Bin-Carting Route</i>	Travel path for transporting bins from their allocated storage location to the nominated collection point
<i>Bin Hoist</i>	A device used for lifting or lowering bins between different levels
<i>Bin Lifter</i>	A device used to mechanically lift bins for the purpose of emptying them into larger bins and/or compactors.
<i>Bin Mover</i>	Either a handheld device (commonly referred to as a bin tug) or a ride-on device (typically a tractor or Class C vehicle with an attached bin trailer) used to facilitate the movement of bins across long distances or up ramps
<i>Bulk Bins</i>	Containers with a capacity greater than 1100L designed to be collected by a front-loading vehicle
<i>Bulky Waste</i>	Recycling items that are too large to be deposited into bins, including furniture, whitegoods, electronics and mattresses
<i>Chute</i>	A vertical pipe passing from floor to floor of a building with openings at each level for the disposal of general waste, recycling or FOGO.
<i>Chute Discharge</i>	The termination point of a chute whereby the chute offsets deposited general waste, recycling or FOGO into bins
<i>Chute Discharge Room</i>	A room enclosing the termination point of the chute/s, including bins and volume handling equipment that is accessible only to the building caretaker
<i>Collection Area/Point</i>	Designated area or point where bins are loaded onto the collection vehicle for servicing
<i>Compactor</i>	A device used for compressing general waste inside it's bin typically at a ratio of 2:1
<i>Comingled Recycling</i>	Waste stream for the recycling of plastic bottles, other plastics, paper, glass and metal containers
<i>Communal Bin Room</i>	A central, shared bin room accessible to all residents or staff to dispose of their waste stream
<i>DA</i>	Development Application
<i>DCP</i>	Development Control Plan
<i>eDiverter</i>	A single chute fitted with a diversion system to allow two separate waste streams (typically general waste and recycling) to be disposed of concurrently.
<i>EPA</i>	Environment Protect Authority
<i>FOGO</i>	Food Organics and Garden Organics
<i>General Waste</i>	All non-recyclable and non-hazardous waste that is sent to landfill
<i>HRV</i>	Heavy Rigid Vehicle

<i>Kerbside Collection</i>	A collection arrangement whereby bins are presented in a single row along the kerb and serviced by a collection vehicle on the street.
<i>L</i>	Litre
<i>LEP</i>	Local Environmental Plan
<i>Mixed Use Development</i>	A development comprising a combination of both residential and commercial units or two or more different land uses within the one development.
<i>Mobile Bins</i>	Containers with a capacity up to and including 1100L designed to be collected by a rear-loading vehicle
<i>Multi-unit Residential Development</i>	Also known as MUD's, residential flat buildings, or apartment blocks, this is a residential development with multiple units that typically share facilities and services such as bins and collections.
<i>MRV</i>	Medium Rigid Vehicle
<i>Onsite Collection</i>	A collection arrangement whereby all bins are serviced by a collection vehicle within the property boundary, either in the building's basement or at grade and off-street.
<i>Owners Corporation</i>	An organisation or group of persons that is identified by a particular name and that acts, or may act, as an entity
<i>Paper/ Cardboard Recycling</i>	Waste stream for the recycling of paper and cardboard only.
<i>Recycling</i>	Waste stream that combines all recycling, including comingled recycling, paper/cardboard and metals.
<i>Ro-Ro Compactor Unit</i>	A large, portable compactor unit which is collected and serviced by a hook lift vehicle
<i>Service Bins</i>	Supplementary bins which are provided to residents or staff for use during collection periods either in communal bin rooms or under chutes
<i>Source Separation Receptacles</i>	Communal containers used throughout the development for the day-to-day disposal of different waste streams
<i>SRV</i>	Small Rigid Vehicle
<i>Volume Handling Equipment</i>	Equipment which comes in the form of either carousel or linear tracks positioned at the base of the chute/s to mechanically replace full bins with empty bins
<i>Waste Stream</i>	A classification used to describe waste of a particular type (eg. food waste stream)
<i>WHS</i>	Workplace Health and Safety
<i>Wheel-Out Wheel Back</i>	A collection arrangement whereby a collection vehicle parks on the street and collection staff exit the vehicle to wheel each bin from a designated storage area to the vehicle for servicing and returns them upon completion.

1.0 ACKNOWLEDGEMENT OF COUNTRY

Elephants Foot Consulting (EFC) acknowledges that every project we work on takes place on First Peoples land. We recognise Aboriginal and Torres Strait Islander People as Traditional Custodians of this land. We pay respect to ancestors and Elders, past and present.

2.0 INTRODUCTION

Elephants Foot Consulting (EFC) has been engaged to prepare the following Operational Waste Management Plan (OWMP) for the mixed-use development located at 215, 229-239 Pitt St, Merrylands NSW 2160.

Robust waste management strategies are required for new developments to support the design and sustainable performance of the building. It is EFC's belief that a successful waste management strategy contains three key objectives:

- i. **Promote responsible source separation*** to reduce the amount of waste that goes to landfill by implementing convenient and efficient waste management systems.
- ii. **Ensure adequate waste and recycling provisions and procedures*** are established that will cater for potential changes during the operational phase of the development.
- iii. **Comply*** with all relevant council codes, policies, and guidelines.

To achieve these objectives, this OWMP identifies and details the following components:

- Waste streams expected to be generated onsite and anticipated volumes;
- Suitable bin sizes and quantities;
- Waste and recycling disposal procedures;
- Bin room size estimations and equipment recommendations; and
- Waste collection strategies, locations and frequencies.

It is vital that this OWMP is integrated into the overall management of the building and is clearly communicated to all relevant stakeholders.

2.1 SCOPE OF REPORT

This OWMP only applies to the **operational** phase of the proposed development; therefore, the requirements outlined in this OWMP must be implemented during the operational phase of the site and may be subject to review upon further expansion of, and/or changes to the development.

The waste management of the **construction** and **demolition** phases of the development are not addressed in this report. A construction and demolition WMP will need to be provided separately.

2.2 REPORT CONDITIONS

The purpose of this report is to document an OWMP as part of a development application, which is supplied by EFC with the following limitations:

- Drawings, estimates and information contained in this OWMP have been prepared by analysing the information, plans and documents supplied by the client and third parties including Council and other government agencies. The assumptions based on the information contained in the OWMP is outside the control of EFC,
- The figures presented in the report are an estimate only – the actual amount of waste generated will be dependent on the occupancy rate of the building/s and waste generation intensity as well as the building management's approach to educating residents and tenants regarding waste management operations and responsibilities,
- The building manager will adjust waste management operations as required based on actual waste volumes (e.g. if waste is greater than estimated) and increase the number of bins and collections accordingly,
- The report will not be used to determine or forecast operational costs or prepare any feasibility study or to document any safety or operational procedures,
- The report has been prepared with all due care; however no assurance is made that the OWMP reflects the actual outcome of the proposed waste facilities, services, and operations, and EFC will not be liable for plans or results that are not suitable for purpose due to incorrect or unsuitable information or otherwise,
- EFC offer no warranty or representation of accuracy or reliability of the OWMP unless specifically stated,
- Any manual handling equipment recommended in this OWMP should be provided at the recommendation of the appropriate equipment provider who will assess the correct equipment for supply,
- Design of waste management chute equipment and systems must be approved by the supplier,
- EFC cannot be held accountable for late changes to the design after the OWMP has been submitted to Council,
- EFC will provide specifications and recommendations on bin access and travel paths within the OWMP, however it is the architect's responsibility to ensure the architectural drawings meet these provisions,
- EFC are not required to provide information on collection vehicle swept paths, head heights, internal manoeuvring or loading requirements. It is assumed this information will be provided by a traffic consultant,
- Council are subject to changing waste and recycling policies and requirements at their own discretion.
- This OWMP is only finalised once the draft watermark has been removed. If the draft watermark is present, the information in the OWMP is not confirmed.

3.0 LEGISLATION & GUIDANCE

Waste management and resource recovery regulation in Australia is administered by the Australian Constitution, Commonwealth laws, and international agreements. State and territory governments maintain primary responsibility for controlling development and regulating waste. The following legislation has been enacted in New South Wales, and provides the lawful underpinnings of this OWMP.

- NSW Environmental Planning & Assessment Act 1979
- NSW Protection of the Environment Operations Act 1997
- NSW Waste Avoidance & Resource Recovery Act 2001

At the local level, councils or Local Government Areas (LGAs) require OWMPs to be included in new development applications. This OWMP is specifically required by:

- Cumberland Development Control Plan 2021
- Cumberland Local Environmental Plan 2021

The primary purpose of a Development Control Plan (DCP) is to guide the planning process according to the aims of the corresponding local environmental plan (LEP). The DCP must be read in conjunction with the provisions of the relevant LEP.

Information provided in this OWMP comes from a wide range of waste management guidance at the local, state, and federal levels. The primary sources of guidance include:

- Cumberland Development Control Plan 2021- Chapter G - Miscellaneous Development Controls Part 8 – Waste Management
- NSW Better Practice Guide For Resource Recovery In Residential Developments 2019
- NSW Better Practice Guidelines for Waste Management and Recycling in Commercial and Industrial Facilities 2012
- NSW Waste Avoidance and Resource Recovery (WARR) Strategy 2014-2021
- NSW Waste Classification Guidelines 2014
- Australia's National Waste Policy 2018

4.0 DEVELOPMENT OVERVIEW

The proposed development falls under the LGA of Cumberland City Council, and consists of:

- A building with 35 levels and 5 basement levels
 - 238 residential units in total.
 - Retail tenancies with a total GFA of 627 m²
 - Commercial tenancies with a total GFA of 2,289 m²

All figures and calculations are based on area schedules as advised by our client and shown on architectural drawings.

4.1 SITE LOCATION

The site is located at 215, 229-239 Pitt St, Merrylands NSW 2160, as shown in Figure.1 (boundaries are indicative only). The site has frontages to Pitt Street, Milne Lane, Reyes Lane and McFarlane Street, with vehicle access via Milne Street and Reyes Lane.

Figure 1: Site Location



Source: Google Earth 2025

5.0 RESIDENTIAL WASTE MANAGEMENT

The following section outlines best practice waste management for the residential component of the development, including waste stream generation estimates and disposal and collection procedures.

5.1 RESIDENTIAL WASTE GENERATION ESTIMATES

The *Cumberland Development Control Plan (2021) - Part G8 - Waste Management* has been referenced to calculate the total number of residential general waste and recycling bins while the *NSW EPA's Better Practice Guide for Resource Recovery in Residential Developments (2019)* has been referenced to calculate the total number of residential FOGO bins.

Calculations are based on generic general waste, recycling and Food Organics and Garden Organics (FOGO) rates. Actual volumes of general waste, recycling and FOGO generated in operation may differ according to the residents' actual waste management practices.

The following tables shows the estimated volume (L) of general waste, recycling and FOGO generated by the residential component of the development.

Table 1: Estimated Waste and Recycling Volumes – Residential

# Units	General Waste Generation Rate (L/unit/week)	Generated General Waste (L/week)	Recycling Generation Rate (L/unit/week)	Generated Recycling (L/week)
238	135	31995	80	18960
Bins & Collections	General Waste Bin Size (L)	1100	Recycling Bin Size (L)	1100
	General Waste Bins per Week	29.2	Recycling Bins per Week	17.5
	General Waste Collections per Week	2	Recycling Collections per Week	1
	Total General Waste Bins Required	15	Total Recycling Bins Required	18
	General Waste Bins per Day	4.2	Recycling Bins per Day	2.5

Table 2: Estimated FOGO Volumes – Residential

# Units	FOGO Waste Generation Rate (L/unit/week)	Generated FOGO Waste (L/week)
238	25	5925
Bins & Collections	FOGO Waste Bin Size (L)	240
	FOGO Waste Bins per Week	24.8
	FOGO Waste Collections per Week	1
	Total FOGO Waste Bins Required	25

Note: At the time of writing, Council do not have an active FOGO collection service. Provision for FOGO bins at this development have been included to account for a future FOGO collection service.

5.2 RESIDENTIAL BIN SUMMARY

Based on the estimated volumes of general waste, recycling and FOGO generated by the residential component of this development, the recommended bin quantities and collection frequencies are as follows:

General Waste: 15 x 1100L bins collected **2 x weekly**

Recycling: 18 x 1100L bins collected **1 x weekly**

FOGO: 25 x 240L bins collected **1 x weekly**

During operation, it is the responsibility of the building manager to monitor the number of bins required for the residential component of the development. General waste, recycling and FOGO volumes may change according to residents' attitudes to waste disposal, building occupancy levels or the development's management. Any requirements for adjusting the capacity of the waste facilities may be achieved by changing the number of bins, the bin sizes or collection frequencies. Building management will be required to negotiate any changes to bins or collections with the collection service provider.

5.3 RESIDENTIAL CHUTE DISCHARGE EQUIPMENT SUMMARY

Cumberland Council has a requirement that the equipment at the base of the chute has capacity for 3 days' worth of general waste generation. For functionality the equipment at the base of the chute must manage at least one day's worth of waste generation.

Based on the estimated general waste volumes generated by each building/core, the following equipment is recommended:

Table 3: Chute Discharge Equipment Summary – General Waste

General Waste Volume Handling Equipment		
Generated General Waste (L/week)	# 1100L Bins Required for 1 days' Capacity	Recommended Chute Discharge Equipment
31995	4.16	4-bin carousel for 1100L bins – custom solution required

Table 4: Chute Discharge Equipment Summary – Recycling

Recycling Volume Handling Equipment		
Generated Recycling (L/week)	# 1100L Bins Required for 1 days' Capacity	Recommended Chute Discharge Equipment
19040	2.47	3-Bin Linear System

The above is a recommendation only and equivalent volume handling equipment may be used subject to equipment supplier's recommendation/review.

5.4 RESIDENTIAL WASTE DISPOSAL PROCEDURES

All units will be provided with a storage area capable of holding separate receptacles for general waste, recycling and FOGO. This is typically located within kitchen areas beneath the workbench. This space should be sized to accommodate 40L receptacles (minimum) to account for 2 days' worth of general waste, recycling and 20L for FOGO storage.

5.4.1 RESIDENTIAL GENERAL WASTE AND RECYCLING DISPOSAL PROCEDURES

Dual chute systems comprising of a single general waste chute and single recycling chute will be installed. Access will be provided to all residents on each residential level.

Residents will be responsible for walking their general waste and recycling to their allocated disposal point and placing their general waste into the general waste chute and recycling into the recycling chute.

Residents will wrap or bag their general waste before placing in the general waste chute. Bagged waste should not exceed 3kg in weight, or 35cm x 35cm x 35cm. Residents will be responsible for loosely placing their recycling into the recycling chute. Recycling should be clean and must not be bagged as soft plastics contaminate recycling.

Cardboard boxes or large containers should not be disposed of in the recycling chute. These items should be disposed of directly into the collection bins in coordination with the building manager.

The general waste will discharge from the chute into 1100L bins on carousel tracks and the recycling will discharge into 1100L bins on linear or carousel tracks in the Chute Discharge Rooms located on the ground level mezzanine.

The building manager will monitor bin capacities under the dual chute systems and exchange full bins with empty bins on the track systems when required.

Full and spare bins will be kept in the Chute Discharge Room/ Residential Bin Holding Room.

5.4.2 RESIDENTIAL FOGO DISPOSAL PROCEDURES

The majority of organics waste generated from multi-unit residential developments comprises of food waste as opposed to garden waste. As such, calculations and management recommendations provided in this report considers that FOGO bins will primarily comprise of food organics.

The residents of each unit will be provided with a kitchen caddy for the separation of FOGO. Food organics must be contained in accordance with Cumberland Council's future FOGO collection service procedures (for example a compostable liner). Any clippings from residential units can also be disposed of with the FOGO.

The building will be provided with a Communal FOGO Bin Room which contains 240L bins for FOGO. The residents will be responsible for walking their FOGO down to the Communal FOGO Bin Room and placing it into the bins.

The Communal FOGO bin room will have capacity for 3 day's worth of bins. The building Manager will monitor the fullness of bins in the Communal FOGO bin room and rotate full bins with empty bins. Full and spare bins will be kept in the Residential Bin Room.

Building management is responsible for ensuring that the Communal FOGO Bin Room and FOGO bins are washed down frequently to ensure that hygiene and odour is managed.

5.5 RESIDENTIAL BIN COLLECTION PROCEDURES

Council will be engaged to collect the residential general waste, recycling and FOGO in accordance with Council's collection schedule. This report assumes that FOGO and Recycling is collected weekly and General Waste is collected twice weekly. It is also assumed that FOGO is collected on a separate day to the General Waste and Recycling collections.

Prior to collections, the Building Manager will be responsible for transporting the bins from the Chute Discharge Room/ Residential Bin Holding Room on the mezzanine to the Temporary Bin Presentation Area adjacent to the loading dock on ground level. It is recommended that service bins are placed at the base of the chute.

The Building Manager is also responsible for ensuring that the bins are adequately arranged for an efficient collection and that the loading area is clear of any vehicles or obstructions prior to waste collection.

On the day of collection, a Council collection vehicle will enter the site from Milne Lane and park in the loading dock. The collection staff will exit the vehicle and collect the bins from the Temporary Bin Presentation Area.

Upon completion of servicing, the collection vehicle will exit the site onto Milne Lane in a forward direction.

The Building Manager is responsible for returning the empty bins to their operational location to resume use.

All access and clearances to the collection point must be able to accommodate a HRV per AS2890.2-2002.

5.6 OTHER RESIDENTIAL WASTE MANAGEMENT CONSIDERATIONS

The following sections outline other waste management considerations for the residential components.

5.6.1 RESIDENTIAL COMMON AREAS

Residential common areas will be supplied with suitably branded source separation receptacles where considered appropriate. Receptacles should be placed in convenient locations which are accessible to all residents. The building manager will monitor the capacity of these receptacles and empty the contents into the central collection bins as required.

5.6.2 LANDSCAPED AREAS AND GARDEN ORGANICS

Garden organics generated from surrounding landscaped areas and indoor foliage typically consists of lawn clippings, cuttings, leaves and branches.

Garden organics generated from surrounding landscaped areas will be managed and removed from the site by the designated landscaping contractors as they carry out scheduled landscaping maintenance works.

Garden organics generated from within residential units will be managed by the residents and should be disposed of into the FOGO bins.

5.6.3 RESIDENTIAL BULKY WASTE PROCEDURES

An area will be made available for the storage of discarded residential bulky waste items (e.g. whitegoods, furniture, etc.). This room should be located within close proximity of the collection point and must have a minimum doorway width of 1.5m to facilitate the movement of large items in and out of the room.

As per the Cumberland Development Control Plan (2021) - Part G8 - Waste Management, Council requires the size of the Bulky Waste Room to be proportional to the number of units in the building. The required space is 10m² for the first 40 units, with an additional 2m² for every 10 units thereafter. Additionally, space for a charity bin or other recycling collection must be provided, with a minimum area of 6m².

Based on this rate, the Bulky Waste Room required is as follows;

Bulky Waste Room Size

$$2 \left(\frac{(237 - 40)}{10} \right) + 10 = 49.4$$

bulky waste storage area: minimum 50m² + 6m² for a charity bin or other.

Residents will need to liaise with building management regarding the transportation of bulky items and the availability of the Bulky Waste Room. It is the caretaker's responsibility to arrange collection dates with Council and coordinate these times with the residents.

Prior to the schedule bulky waste collection, the Building Manager will transport the bulky waste from the Bulky Waste Room to the Temporary Bin Presentation Area in the Loading Area on ground level.

On the day of bulky waste collection, a Council collection vehicle will enter the site from Milne Lane and park in the loading dock. Collection staff will collect the bulky waste items from the Temporary Bin Presentation Area. Once bulky items have been loaded onto the vehicle, the collection vehicle will exit the site onto Milne Lane in a forward direction.

6.0 COMMERCIAL AND RETAIL WASTE MANAGEMENT

The following section outlines best practice waste management for the commercial and retail components of the development, including waste generation estimates and waste disposal and collection procedures.

6.1 COMMERCIAL AND RETAIL WASTE GENERATION ESTIMATES

The *Cumberland Development Control Plan (2021) - Part G8 - Waste Management* has been referenced to calculate the total number of bins required for the anticipated tenants. Calculations are based on generic generation rates. Actual volumes of waste and recycling may differ in operation according to the tenants' actual waste management practices.

The following table shows the estimated volume (L) of general waste and recycling that will be generated by the commercial and retail tenants.

These estimates are based on a five-day operating week for the commercial offices and a seven-day operating week for the retail tenancies. The total GFA of the retail component has been divided into two to take into account the waste generation of future possible tenancies. It is assumed that retail tenancies will share bins, bin storage facilities and collections.

Table 5: Estimated Waste and Recycling Volumes – Commercial and Retail

Name of Generation Rate	Floor Area (m ²)	General Waste Generation Rate (L/100m ² /day)	Generated General Waste (L/week)	Recycling Generation Rate (L/100m ² /day)	Generated Recycling (L/week)
Restaurants, Cafe	313.5	660	14484	130	2853
Shops (>100m ²)	313.5	50	1097	50	1097
Offices	2289	10	1145	10	1145
TOTAL	2916.0		16725		5095
Bins & Collections		General Waste Bin Size (L)	1100	Recycling Bin Size (L)	1100
		General Waste Bins per Day	2.2	Recycling Bins per Day	0.7
		General Waste Collections per Week	3	Recycling Collections per Week	3
		Total General Waste Bins Required	7	Total Recycling Bins Required	2

6.2 COMMERCIAL AND RETAIL BIN SUMMARY

Based on the estimated waste and recycling volumes generated the commercial and retail tenancies, the recommended bin quantities and collection frequencies are as follows:

General Waste: 7 x 1100L bins collected **every 3 days (2-3 times weekly)**

Recycling: 2 x 1100L bins collected **every 3 days (2-3 times weekly)**

Bin sizes, quantities, and/or collection frequencies may be modified by the building manager once the proposed development is operational. Building management will be required to negotiate any changes to bins or collections with the collection service provider. Seasonal peak periods should also be considered.

6.3 COMMERCIAL AND RETAIL WASTE DISPOSAL PROCEDURES

Each tenancies will be responsible for their general waste and recycling management within their tenancy space.

On completion of each trading day or as required, nominated staff or contracted cleaners will transport all general waste and recycling to the Retail/Commercial Bin Room and place into the appropriate collection bins.

6.4 COMMERCIAL AND RETAIL WASTE COLLECTION PROCEDURES

A private waste contractor will be engaged to service the retail general waste and recycling bins as per an agreed collection schedule. This report assumes that general waste and recycling is collected every 3 days (2-3 times weekly).

On the morning before the commercial/retail collection, the building manager will move the retail/commercial bins from the Retail/Commercial Bin Room to the temporary bin presentation area.

On the day of service, a private waste collection vehicle will enter the site from Milne Lane and park in the loading bay. The waste collection staff will collect the bins directly from the Temporary Bin Presentation Area. Once the bins are serviced, the collection vehicle will exit the site onto Milne Lane in a forward direction.

As soon as possible, the same day as collection the building manager is responsible for returning the retail/commercial bins to the Retail/Commercial Bin Room

Please note: The collection of commercial/retail bins must occur on separate days from the collection of residential bins to minimise conflicting uses of the loading area.

6.5 OTHER COMMERCIAL AND RETAIL WASTE MANAGEMENT CONSIDERATIONS

Based on the types of tenancies anticipated for this development, the following waste management practices are recommended.

6.5.1 WASHROOM FACILITIES

Washroom facilities should be supplied with collection bins for paper towels (if used). Sanitary bins for female restroom facilities must also be arranged with an appropriate contractor.

6.5.2 PRINTING & PHOTOCOPYING ROOMS

It is recommended that rooms designed for printing or photocopying be provided with an area for the interim storage of paper receptacles, as well as separate receptacles for used toner and/or printer cartridges for recycling. The cleaners or nominated staff are responsible for monitoring these receptacles and ensuring that items are collected and recycled by an appropriate contractor.

6.5.3 LIQUID WASTE

Liquid wastes such as cleaning products, chemicals, paints, solvents, and motor and cooking oil will be stored in a secure room and enclosed by a low wall intended to contain any liquid spillage or inundation to other areas. Liquid waste will be drained to a grease trap, in accordance with legislation and the requirements of State government authorities and agencies. Further information can be provided by the Services Consultant.

6.5.4 PROBLEM WASTE

The building manager is responsible for making arrangements for the disposal and recycling of problem waste streams with an appropriate contractor. Problem wastes cannot be placed in the general waste stream as they can have adverse impacts to human health and the environment if disposed of in landfill. Retail and commercial tenants must liaise with the building manager when disposing of problem waste streams.

Problem waste streams include:

- Chemical Waste
- Liquid wastes
- Toner cartridges
- Lightbulbs
- eWaste
- Batteries

7.0 STAKEHOLDER ROLES & RESPONSIBILITIES

The following table outlines the primary roles and responsibilities of the respective stakeholders:

Table 6: Stakeholder Roles and Responsibilities

Roles	Responsibilities
Strata, Body Corporate or Management	<ul style="list-style-type: none"> • Co-ordinate the waste strategy within the site. • Ensure all waste service providers submit monthly reports on all equipment movements and waste quantities/weights. • Organise internal waste audits/visual assessments on a regular basis. • Purchase any on-going waste management equipment or maintenance of equipment once building is operational; and • Manage any non-compliances/complaints reported through waste audits.
Building Manager or Waste Caretaker	<ul style="list-style-type: none"> • Co-ordinate general waste, recycling and FOGO collections • Clean and transport bins as required. • Maintain and clean chute doors on each level. • Organise replacement or maintenance requirements for bins. • Organise, maintain and clean bin storage areas. • Organise bulky waste collections when required. • Investigate and ensure prompt clean-up of illegally dumped waste materials. • Prevent storm water pollution by taking necessary precautions (secure bin rooms, prevent overfilling of bins). • Abide by all relevant WH&S legislation, regulations, and guidelines. • Provide staff/contractors with equipment manuals, training, health and safety procedures, risk assessments, and PPE to control hazards associated with all waste management. • Assess any manual handling risks and prepare a manual handling control plan for bin transfers. • Ensure site safety for residents, children, visitors, staff and contractors; and • Ensure effective signage, communication and education is provided to occupants, tenants, maintenance staff, and cleaning contractors.
Residents	<ul style="list-style-type: none"> • Dispose of all general waste, recycling and FOGO in the allocated chutes and/or bins provided. • Ensure adequate separation of general waste, recycling and FOGO; and • Comply with the provisions of Council and the OWMP.
Retail/Commercial Tenants	<ul style="list-style-type: none"> • Management co-ordinates own private contractor collections. • Manage general waste and recycling within their tenancy during daily operations. • Correctly separate general waste and recycling streams. • Flatten cardboard within the recycling bin. • If required, arrange for storing used and unused cooking oil in a bunded area, • Organise grease interceptor trap servicing, and • Ensure the suitable storage for chemicals, pesticides and cleaning products waste back of house.
Waste Collection Contractor	<ul style="list-style-type: none"> • Provide a reliable and appropriate bin collection service. • Provide feedback to building managers/residents regarding contamination of recyclables; and • Work with building managers to customise waste systems where possible.
Gardening/Landscaping Contractor	<ul style="list-style-type: none"> • Remove all garden organics generated during gardening maintenance activities for recycling at an offsite location.
Developer	<ul style="list-style-type: none"> • Purchase all equipment required to implement this OWMP prior to the occupation of the building to be provided to the Strata or Body Corporate.

8.0 SOURCE SEPARATION

Better practice waste management includes the avoidance, reuse, and recovery of unwanted items, which can be achieved through source separation. Waste . Refer to your local council for a list of accepted materials. Planet Ark can be accessed online to find other facilities that recover unwanted items.

Table 7: Operational Waste Streams

Waste Stream	Description	Typical Destination	Waste Stream Management
General Waste	The remaining portion of the waste stream that is not recovered for re-use, processing, or recycling. May include soft plastics, food scraps, polystyrene, etc.	Landfill	Waste should be bagged before placing in chutes, or in designated waste bins.
Recycling	A mixture of items that are commonly recycled usually segregated through a MRF. Typically include food and beverage containers (e.g. aluminium, glass, steel, hard plastics, cartons). Also included cardboard and paper products.	Resource Recovery Centre	Recycling must not be bagged, and instead should be placed loosely in the designated recycling bins. Bulky cardboard must not be placed in any chute. Cardboard should be flattened before placing in the designated recycling bin.
FOGO	FOGO consists of unwanted or uneaten kitchen scraps that are easily compostable/biodegradable (e.g. vegetable peels, fruit rinds, coffee grounds) and garden organics including lawn clippings, leaves, pruning's and branches.	Composting Facility	FOGO should be bagged in compostable liners when deposited into the chute/s or bins and will be collected by Council.
Garden Organics	Garden organics consists of unwanted organic materials that are easily biodegradable and/or compostable (e.g. lawn clippings, branches)	Resource Recovery Centre	Landscape Maintenance Contractors will remove the garden organics from site during scheduled maintenance. Garden organics will be collected in Council or private contractor bins and removed from site.
Secure Documents	Secure documents are printed paper materials that contain sensitive information.	Recycling Facility	Secure documents are placed in allocated secure document bins. Private contractor removes bins from site.
Electronic Waste	Discarded e-waste, electronic components and materials such as computers, mobile phones, keyboards, etc.	Resource Recovery Centre	Building manager arranges collection for e-waste recycling as needed by residents. Commercial tenants arrange for recycling of their e-waste.
Bulky Waste Items	Items that are too large to place into general rubbish collection. This includes disused and/or broken furniture, mattresses, white goods, etc.	Resource Recovery Centre or Landfill	Residents liaise with building manager to store in Bulky Goods Room. Building manager arranges with Council for removal. Commercial tenants are responsible for removal of their bulky items.
Sanitary Waste	Feminine hygiene waste generated from female bathrooms.	Incineration or Landfill	Sanitary bins are serviced by sanitary waste contractor.
Other	Other recyclable items that require special recovery may include ink cartridges, batteries, chemical waste, fluorescent tubes, etc.	Resource Recovery Facility	Building manager arranges collection by appropriate recycling services when required.

9.0 EDUCATION

Educational material encouraging correct separation of general waste, recycling and FOGO must be provided to each resident and commercial/retail tenant. This should include the correct disposal process for bulky waste such as old furniture, large discarded items, and other materials including electronic and chemical wastes. It is recommended that the building caretaker provide information in multiple languages to support correct behaviours, and to minimise the possibility of chute blockages and contamination in communal bins.

Education and communication must be provided consistently on a regular basis to encourage behaviour change and account for transient building personnel such as new residents, tenants, or cleaning staff. It is also recommended that the owners' corporation website contain information for residents' referral regarding use of the chute. Information should include:

- Directions on using the chute doors;
- Descriptions of items accepted in the general waste, recycling and FOGO streams (refer to Council guidance);
- How to dispose of bulky waste and any other items that are not general waste, recycling or FOGO (refer to Council guidance);
- Residents' obligations to health and safety as well as building management; and
- How to prevent damage or blockages to the chute (example below).

9.1 SIGNAGE

Signage and education are essential components to support best practice waste management including resource recovery, source separation, and diversion of waste from landfill.

Signage should include:

- Clear and correctly labelled bins,
- Instructions for separating and disposing of waste items. Different languages should be considered,
- Locations of, and directions to, the waste storage areas with directional signs, arrows, or lines,
- The identification of all hazards or potential dangers associated with the waste facilities, and
- Emergency contact information should there be issues with the waste systems or services in the building.

The building manager is responsible for waste room signage including safety signage. Appropriate signage must be prominently displayed on doors, walls and above all bins, clearly stating what type of waste or recyclables is to be placed in each bin.

All chute doors on all residential levels will be labelled with signs directing chute operations and use of chute door.

All signage should conform to the relevant Australian Standards.

10.0 POLLUTION PREVENTION

Building management shall be responsible for the following to minimise dispersion of site litter and prevent stormwater pollution to avoid impact to the environment and local amenity:

- Promoting adequate waste disposal into the bins
- Securing all bin rooms (whilst affording access to staff/contractors)
- Prevent overfilling of bins, keep all bin lids closed and bungs leak-free
- Taking action to prevent dumping or unauthorised use of waste areas
- Require collection contractor/s to clean up any spillage when clearing bins

11.0 BIN WASHING

The bins will be cleaned by the building manager periodically to ensure hygiene and minimise odour.

Bin washing can occur within the bin rooms, using the room clean down facilities (i.e tap connection and drain). Alternatively, a specialist bin washing contractor can be engaged to clean the bins to an agreed schedule. The specialist bin contractor would collect the bins from the bin holding area and clean the bins with their specialised vehicle.

12.0 BIN MOVING PATHS

Minimal movement of bins is anticipated for this site, as bins are to be collected directly from their storage location. The building manager will be responsible for any transportation of bins that does occur.

Any movement of bins should minimise manual handling where possible, as bins become heavy when full. The building manager must assess manual handling risks and provide any relevant documentation to key personal.

The routes along any bin moving paths should;

- Allow for a continuous route that is wholly within the property boundary.
- Be free from obstruction and obstacles such as steps and kerbs.
- Be constructed of solid materials with a non-slip surface
- Be A minimum of 300mm wider than the largest bin used onsite.
- If bins are moved manually, the route must not exceed a grade of 1:14.
- If a bin moving device is used, the route cannot exceed the maximum operating grade of the device. This is typically a grade of 1:4, however this will vary depending on the model of bin moving device acquired for the site.

13.0 EQUIPMENT SUMMARY

Table 8: Equipment Summary

	Part	Qty	Notes
Chutes	Please refer to supplier's information	1	(See APPENDIX: B.1 for Typical Dual Chute Layout)
Chute Equipment	General Waste 4-bin 1100L bin Carousel or custom solution	1	(See Appendix C.3 for Typical Carousel)
	Recycling 3-bin 1100L bin Linear track	1	(See Appendix C.4 for Typical Linear)
Other Equipment	240L Bin Lifter (to decant 240L recycling bins into 1100L bins for collection)	1	(See APPENDIX: D.5 for Typical Bin Lifter)

14.0 WASTE ROOMS

The areas allocated for waste storage and collection areas are detailed in the table below and are estimates only.

Table 9: Waste Room Areas

Level	Waste Room Type	Equipment	Estimated Area Required (m ²)
Ground – Mezzanine	Chute Discharge Room and Residential Bin Holding Room	<i>Chute Discharge -</i> General Waste: 1x 4-bin 1100L bin Carousel Recycling: 1x 3-bin 1100L bin Linear Track Service Bin: 2x 1100L bin General Waste: 11 x 1100L bins Recycling: 15 x 1100L bins	>144
Ground – Mezzanine	FOGO Bin Room	FOGO: 25 x 240L bins	>25
Ground	Temporary Bin Presentation Area (collection point)	<i>Maximum bins – Residential Collection:</i> General Waste: 15 x 1100L bins Recycling: 18 x 1100L bins	>107
Basement Level 3	Bulky Waste Room	50m ² for bulky waste 6m ² for charity bins	>56
Ground	Retail/ Commercial Bin Room	General Waste: 7 x 1100L bins Recycling: 2 x 1100L bins	>32

The “estimated area required” in the table above have been calculated based on equipment requirements and/or bin dimensions with an additional 90% of bin GFA factored in for manoeuvrability. Other factors such as the shape of the room, position of the chutes, configuration of the equipment, access needs and position of the door may impact the size of the room required. Thus a smaller or larger room size may also be suitable for purpose, as long as the room can accommodate the required equipment with adequate access.

In addition, all doorways and passageways facilitating the movement of bins and/or bulky waste items must be at least 1500mm wide.

The following table provides further waste room requirements.

Table 10: Waste Room Requirements

Waste Room Type	Waste Room Requirements
Chute Discharge Room	<ul style="list-style-type: none"> • Ceiling clearance height must be a minimum of 3000mm (3100mm with compactor) (subject to penetration location) • The chute penetration must have a minimum 500mm clearance of any service pipes or other overhead obstacles • All chute discharge points should be caged off to ensure the safety of any personnel accessing the waste room • 200mm clearance is required around compaction equipment • Where a chute offset is required, the angle of the offset must not exceed 30 degrees (subject to number of consecutive offset and/or up to 1500mm) • Where the chute discharge room also acts as the collection point, the chute discharge and any equipment underneath the chute should be caged off to ensure the safety of personnel accessing the room.
Residential Bin Room and/or Bin Collection Area	<ul style="list-style-type: none"> • Bins must not be stacked in rows that are more than two bins deep.
Communal FOGO Rooms	<ul style="list-style-type: none"> • Bins should be arranged so that all bins are accessible. Bins are not to be placed in front of one another or in such a way as to restrict access to the other bins for use. • Rooms must be well ventilated either naturally or mechanically in accordance with AS1668.4.2012 • Cleaning facilities such as hose hock and drainage for odour and hygiene control must be provided. • It is recommended a dustpan and broom is provided in this room for residents to clean up unexpected spillages when using bins.
Bulky Waste Room	<ul style="list-style-type: none"> • May be a dedicated room or screened area within another waste room • Must be in close proximity to the collection area • Area must also be allocated for the segregation of e-waste, gas bottles, cardboard, etc. • Doorway should be a minimum of 1500mm wide
Retail/Commercial Bin Room	<ul style="list-style-type: none"> • In order to ensure staff safety, all bins should be arranged so they can be accessed without moving another bin • Bins must be coordinated with the hinge of the lid facing the back. This is to allow for ideal access to the bin.

15.0 CONSTRUCTION REQUIREMENTS

Waste room construction must comply with the minimum standards as outlined in the *Cumberland Development Control Plan 2021*, in order to minimise odours, deter vermin, protect surrounding areas, and make it a user-friendly and safe area.

The *NSW Better practice guide for resource recovery in residential developments (2019)* also states that better practice bin storage areas should achieve more than the minimum compliance requirements, which are as follows:

- Ensuring BCA compliance, including ventilation. Where required, ventilation system must comply with AS1668.4-2012 The use of ventilation and air conditioning in buildings.
- Ensuring storage areas are well lit (sensor lighting preferred) and have lighting available 24 hours a day.
- Provision of bin washing facilities, including taps for hot and cold water provided through a centralised mixing valve. The taps must be protected from bins and be located where they can be easily accessed even when the area is at bin capacity.
- Floor constructed of concrete at least 75mm thick.
- Floor graded so that any water is directed to a sewer authority approved drainage connection to ensure washing bins and/or waste storage areas do not discharge flow into the stormwater drain.
- Provision of smooth, cleanable and durable floor and wall surfaces that extend up the wall to a height equivalent to any bins held in the area.
- Ensuring ceilings are finished with a smooth-faced non-absorbent material capable of being cleaned.
- All surfaces (walls, ceiling and floors) finished in a light colour.

15.1 ADDITIONAL CONSIDERATIONS

- Waste room floor to be sealed with a two-pack epoxy;
- All corners coved and sealed 1,200mm up, this is to eliminate build-up of dirt;
- Hot and cold water tap height and light switch height of 1.6m;
- Storm water access preventatives (grate);
- All walls painted with light colour and washable paint;
- Equipment electric outlets to be installed 1700mm above finished floor level;
- Optional automatic odour and pest control system installed
- If 660L or 1100L bins are utilised, 2 x 820mm (minimum) double-doors must be used;
- All personnel doors are hinged, lockable and self-closing;
- Conform to the Building Code of Australia, Australian standards and local laws; and
- Childproofing and public/operator safety shall be assessed and ensured
- Waste and recycling rooms must have their own exhaust ventilation system either;
 - Mechanically - exhausting at a rate of 5L/m² floor area, with a minimum rate of 100L/s minimum. Mechanical exhaust systems shall comply with AS1668.4.2012 and not cause any inconvenience, noise or odour problem; or
 - Naturally - permanent, unobstructed, and opening direct to the external air, not less than one-twentieth (1/20) of the floor area.

16.0 USEFUL CONTACTS

EFC does not warrant or make representation for goods or services provided by suppliers.

LOCAL COUNCIL

Cumberland Customer Service Ph: (02) 8757 9000 E: council@cumberland.nsw.gov.au

PRIVATE WASTE COLLECTION PROVIDER

Capital City Waste Services Ph: 02 9599 9999 E: service@ccws.net.au
 Sydney Waste Ph: 02 8661 0031
 Waste Clear Ph: 1300 525 352 E: admin@wasteclear.com.au

BIN MOVING DEVICE SUPPLIERS

Elephants Foot Equipment Ph: 1300 435 374 E: equipment@elephantsfoot.com.au
 Sitecraft Ph: 1300 363 152 E: sales@sitecraft.com.au

BALER SUPPLIERS

Elephants Foot Equipment Ph: 1300 435 374 E: equipment@elephantsfoot.com.au

ORGANIC DIGESTERS AND DEHYDRATORS

Elephants Foot Equipment Ph: 1300 435 374 E: equipment@elephantsfoot.com.au
 Waste Master Ph: 1800 614 272 E: hello@wastemasterpacific.com.au

COOKING OIL CONTAINERS AND DISPOSAL

Cookers Ph: 1300 882 299 E: info@cookers.com.au
 Auscol Ph: 1800 629 476 E: sales@auscol.com

ODOUR CONTROL

Elephants Foot Equipment Ph: 1300 435 374 E: equipment@elephantsfoot.com.au

SOURCE SPERATION BINS

Method Recycling Ph: 0499 890 455

BINS AND BIN EQUIPMENT

Elephants Foot Equipment Ph: 1300 435 374 E: equipment@elephantsfoot.com.au
 SULO Ph: 1300 364 388 E: sulosales@pactgroup.com

CHUTES, COMPACTORS AND EDIVERTER SYSTEMS

Elephants Foot Chute Solutions Ph: 1300 435 374 E: chutes@elephantsfoot.com.au

APPENDIX A: ARCHITECTURAL PLANS

APPENDIX: A.2 GROUND FLOOR PLAN MEZZANINE – WASTE AREAS

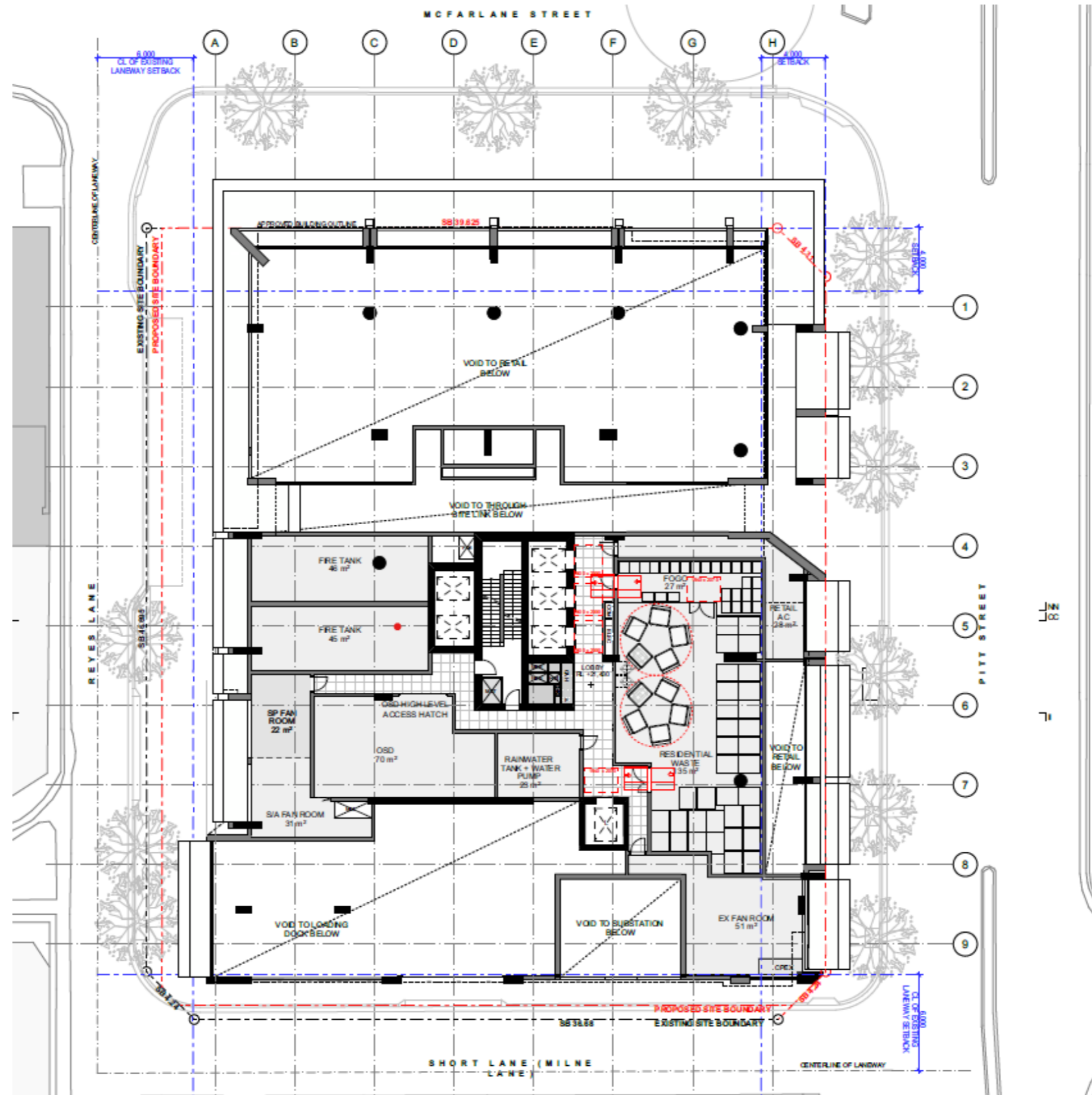

Source Fuse Architects, SSDA 107, Rev A, Oct2025 - Ground Level Plan - Mezzanine:

APPENDIX B: INSTALLATION EQUIPMENT



CHUTE SHAFT & PENETRATION SET-OUT

DUAL Ø610 STEEL

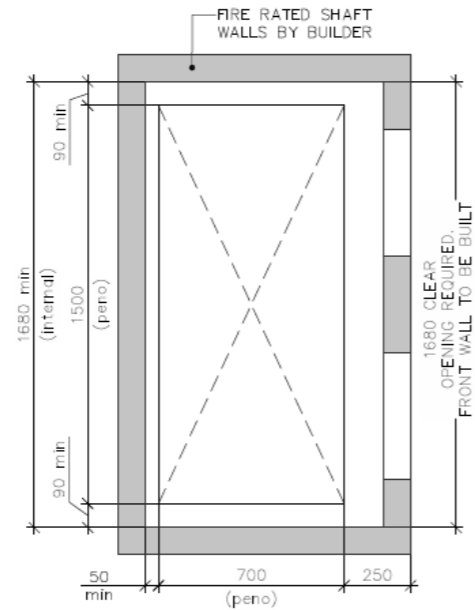

01 DUAL (610Ø) GALV. STEEL CHUTE LAYOUT PENETRATION SET-OUT

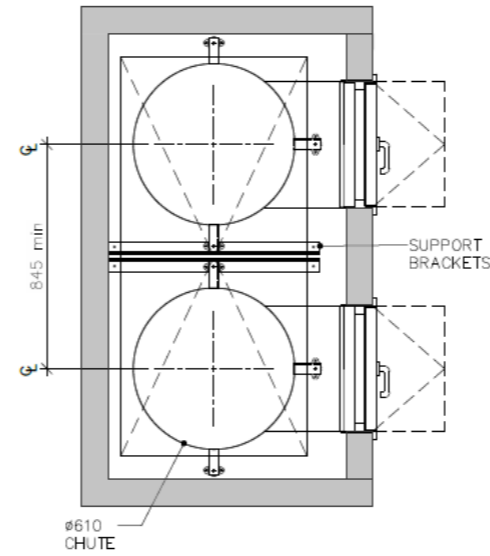

02 DUAL (610Ø) GALV. STEEL CHUTE LAYOUT

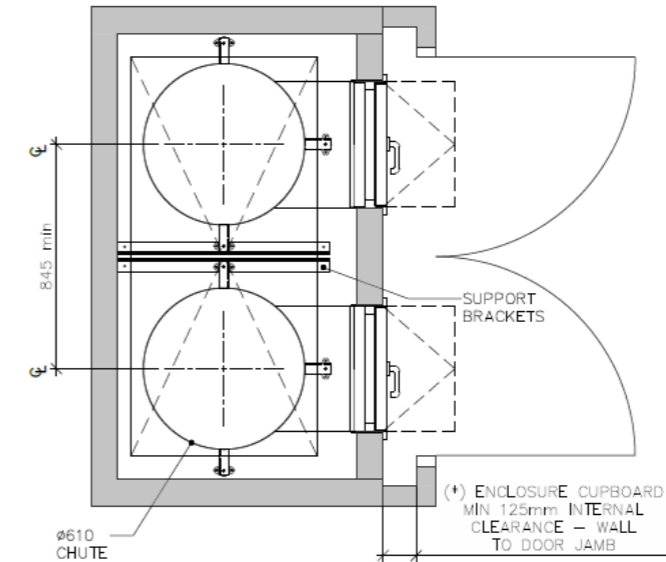

03 DUAL (610Ø) GALV. STEEL CHUTE LAYOUT with ENCLOSURE CUPBOARD (*)

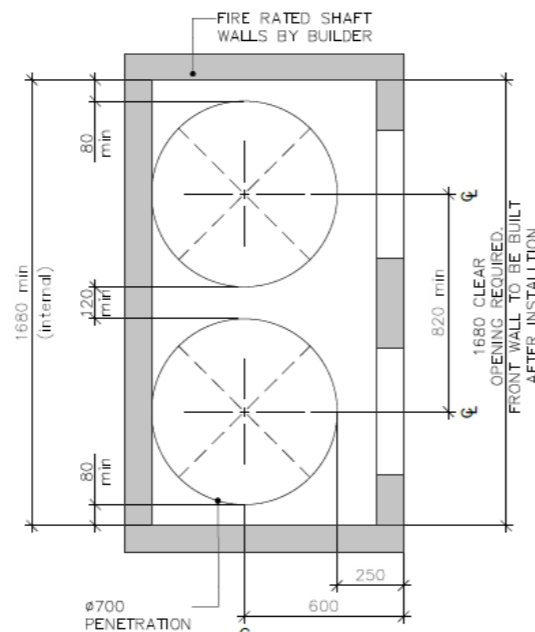

04 DUAL (610Ø) GALV. STEEL CHUTE LAYOUT WITH CIRCULAR PENETRATION SET-OUT

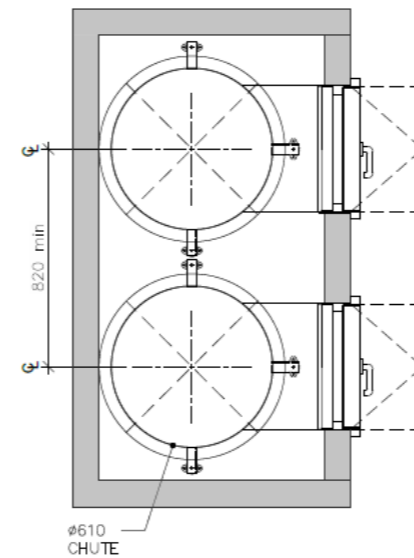

05 DUAL (610Ø) GALV. STEEL CHUTE LAYOUT (W/ CIRCULAR PENETRATION)

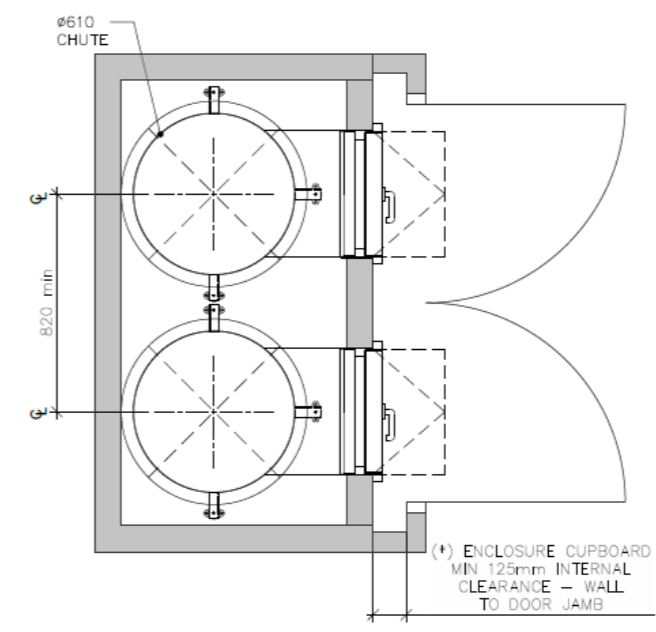

06 DUAL (610Ø) GALV. STEEL CHUTE LAYOUT with ENCLOSURE CUPBOARD (*)

(*) NOTE: ENCLOSURES ARE RECOMMENDED IF THE CHUTE OPENS DIRECTLY TO A CORRIDOR OR IS NOT LOCATED IN A WASTE ROOM. IF CHUTE ACCESS IS WITHIN A WASTE ROOM THEN THE CUPBOARD ENCLOSURES ARE NOT REQUIRED.

SCALE 1:25 @ A3

Chute Shaft & Peno – Ver 1.2 April 26, 2022

Please Note: This is an example only – please refer to supplier's information and specification.

APPENDIX: B.2 EXAMPLE RESIDENTIAL LEVEL RECYCLING BIN LAYOUT

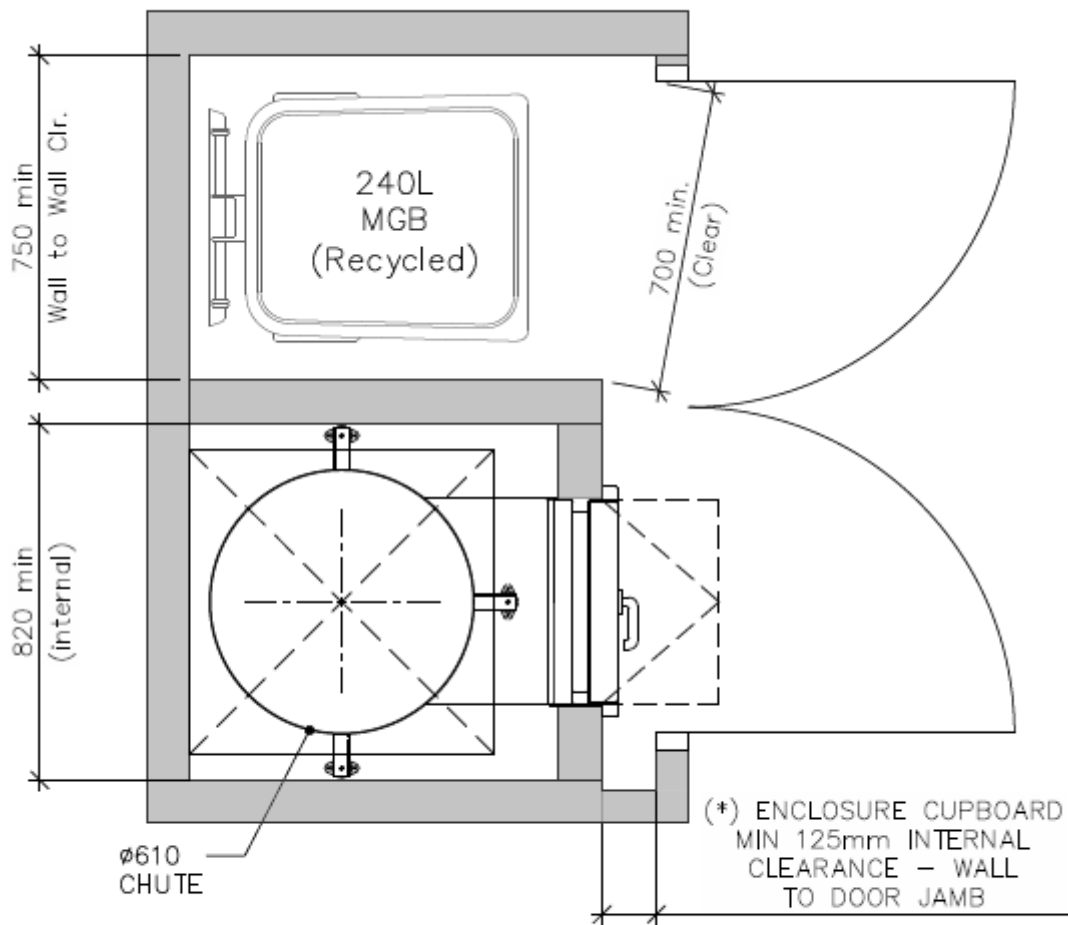

07 TYPICAL (610 ϕ) GALV. STEEL CHUTE LAYOUT
with ENCLOSURE(*) & RECYCLING COMPARTMENT

Please Note: This is an example only – please refer to supplier's information and specification

APPENDIX: B.3 EXAMPLE CAROUSEL SYSTEM FOR 1100L BINS



ELEPHANTS FOOT RECYCLING SOLUTIONS
44-46 GIBSON AVE. PADSTOW NSW 2211
E info@elephantsfoot.com.au W elephantsfoot.com.au
Free Call: 1300 4 ELEPHANT (1300 435 374)

1100 LITRE CAROUSEL SYSTEM

PRODUCT INFORMATION

Elephants Foot 1100 Litre bin Carousel System is a versatile waste handling solution for many types of multi-storey or multi-level developments. The Carousel System collects waste or recycling being disposed from the floors above through the chute system, discharging the material via a hopper that feeds the bins positioned on the unit. Electromechanically driven with automated operation, the Carousel System automatically replaces full bins by a revolving circular platform. Once all the bins on the system are filled, an indicator light will illuminate signifying that the bins are ready for withdrawal and collection. Available with or without compaction unit, our standard 660litre bin Carousel System is available in standard 2, 3 or 4 bin options. Our 5 Bin option is available as a special order.



SPECIFICATIONS

System Control	Electric PLC
Power Supply	415 V AC / 10A / 5 PIN
Motor Size (kW)	0.37
Maximum bin load	440 kg
Noise (dBA)	<85
Bin Size (L)	660
Cycle time (sec)	60
Bin Quantity options	2, 3, 4 or 5

STANDARD FEATURES & BENEFITS

OPTIONAL EXTRAS

- Compaction unit – Please refer to the bin compactor product information sheet for details and specifications
- Enhanced safety add on's - Interlocking barriers, occupancy sensors or safety light curtains (presence sensing light barriers)
- Full bin SMS and email notification
- CMMS and BMS integration
- Extend warranty – Terms and conditions apply

- Simple operation with user friendly controls
- Increased waste servicing efficiency for the development.
- Automatic system control with manual override
- Robust unit construction for long performance life
- Low service and maintain costs
- Rotating flashing beacon (activated during operation)
- Quiet and efficient system operation
- Maximise safety for residents, caretakers and collectors
- Restrained design with minimal moving parts
- Can suit low ceiling clearances
- Floor contact components fully galvanised steel
- Retro fitting options to suit other chutes systems
- Compliant with relevant Building Codes and Standards
- Standard 12 month warranty



1,100 LITRE CAROUSEL SYSTEM

No. of Bins	Reference (mm)			
	A	B	C	D
2	650	1700	3200	3350
3	650	1850	3480	3800
4	650	2050	3940	4050

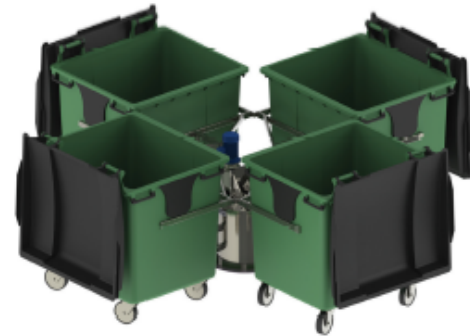

Available with or without compaction unit, our standard 1100 litre bin Carousel System is available in standard 2, 3 or 4 bin options. Our 5 Bin option is available as a special order.

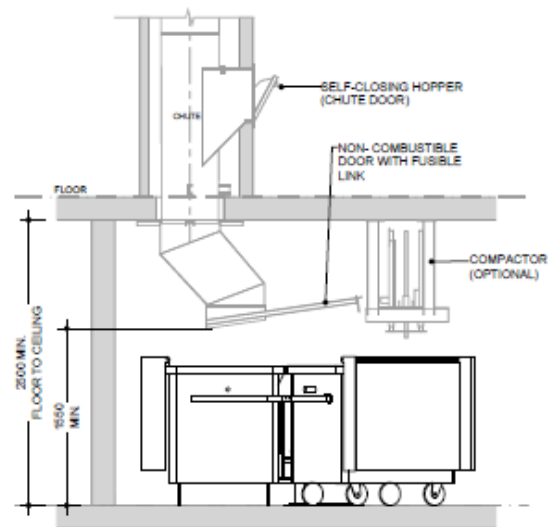
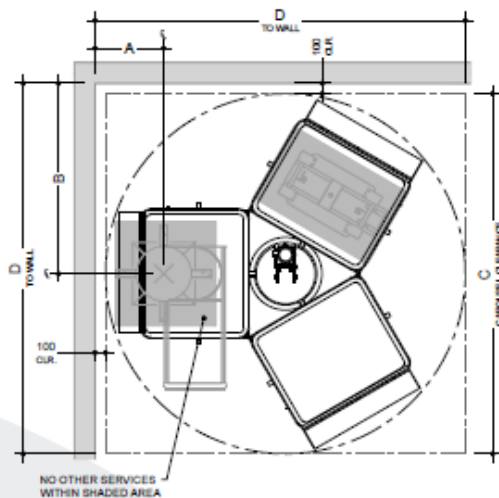

Notes:

Bins not provided by Elephants Foot

Drawings shown are for general information purposes only and provide minimum equipment spacial requirements for waste room design.

These drawings are not intended for site specific use or for construction. Each project is unique and will be designed to suit.

Additional equipment options, systems and configurations are available. For design assessment, information and advice, please contact an Elephants Foot design consultant on 1300 435 374

Please Note: This is an example only – please refer to supplier's information and specification

APPENDIX: B.4 TYPICAL LINEAR TRACK SYSTEM FOR 1100L BINS



1100 LITRE LINEAR TRACK SYSTEM

PRODUCT INFORMATION

Elephants Foot 1100 Litre bin Linear Track System is a versatile waste handling solution for many types of multi-storey or multi-level developments. The Linear Track System collects waste or recycling being disposed from the floors above through the chute system, discharging the material via a hopper that feeds the bins. Electromechanically driven with automated operation, the system utilises linear motion to automatically change over full bins. Once all the bins are filled, an indicator light will illuminate signifying that the bins are ready for withdrawal and collection. Available with or without compaction unit, our standard 660 litre bin Linear Track System is available in the standard 2 bin option. Our 3 Bin option is available as a special order.



SPECIFICATIONS

System Control	Electric PLC
Power Supply	415 V AC / 10A / 5 PIN
Motor Size (kW)	1.1
Maximum bin load	440 kg
Noise (dBA)	<85
Bin Size (L)	1100
Cycle time (sec)	60
Bin Quantity options	2 or 3

OPTIONAL EXTRAS

- Compaction unit – Please refer to the bin compactor product information sheet for details and specifications
- Enhanced safety add on's – Interlocking barriers, occupancy sensors or safety light curtains (presence sensing light barriers)
- Full bin SMS and email notification
- CMMS and BMS integration
- Extend warranty – Terms and conditions apply

STANDARD FEATURES & BENEFITS

- Simple operation with user friendly controls
- Increased waste servicing efficiency for the development.
- Automatic system control with manual override
- Robust unit construction for long performance life
- Low service and maintain costs
- Rotating flashing beacon (activated during operation)
- Quiet and efficient system operation
- Maximise safety for residents, caretakers and collectors
- Restrained design with minimal moving parts
- Can suit low ceiling clearances
- Floor contact components fully galvanised steel
- Retro fitting options to suit other chutes systems
- Compliant with relevant Building Codes and Standards
- Standard 12 month warranty



1,100 LITRE LINEAR TRACK SYSTEM



No. of Bins	Reference (mm)		
	A	B	C
2	900	3700	5300
3	2100	5940	7550

Available with or without compaction unit, our standard 1100 litre bin Linear Track System is available in the standard 2 bin option. Our 3 Bin option is available as a special order.

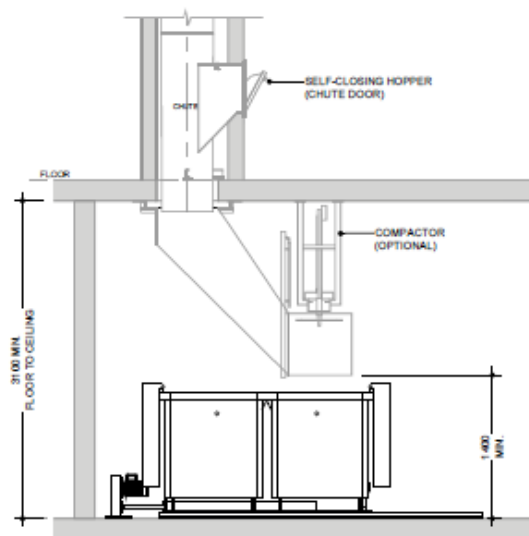
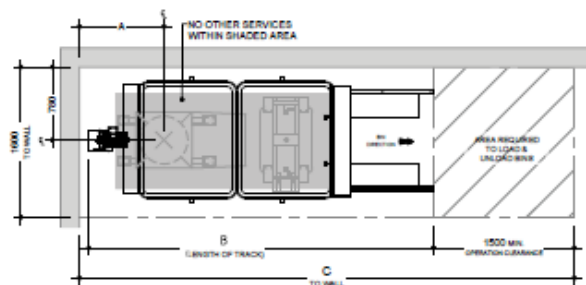

Notes:
Bins not provided by Elephants Foot

Drawings shown are for general information purposes only and provide minimum equipment spacial requirements for waste room design.

These drawings are not intended for site specific use or for construction. Each project is unique and will be designed to suit.

Additional equipment options, systems and configurations are available. For design assessment, information and advice, please contact an Elephants Foot design consultant on 1300 435 374

Please Note: This is an example only – please refer to supplier's information and specification

APPENDIX C: PRIMARY WASTE MANAGEMENT PROVISIONS

APPENDIX: C.1 TYPICAL BIN SPECIFICATIONS

Mobile bins

Mobile bins come in a variety of sizes and are designed for lifting and emptying by purpose-built equipment.

Mobile bins with capacities of up to 1700L must comply with *AS4123.6-2006 Mobile waste containers* which specifies standard sizes and sets out the colour designations for the bodies and lids of mobile waste containers indicating the type of materials they are used to collect.

The most common bin sizes are provided below, although not all sizes are shown. The dimensions are a guide only and differ slightly between manufacturers. Some bins have flat or domed lids and are used with different lifting devices. Refer to *AS4123.6-2006* for further details.

Table G1.1: Average dimension ranges for two-wheel mobile bins



Bin capacity	80L	120L	140L	240L	360L
Height (mm)	870	940	1065	1080	1100
Depth (mm)	530	530	540	735	820
Width (mm)	450	485	500	580	600
Approximate footprint (m ²)	0.24	0.26–0.33	0.27-0.33	0.41–0.43	0.49
Approximate weight (kg)	8.5	9.5	10.4	15.5	23
Approximate maximum load (kg)	32	48	56	96	Not known

Wheelie bin

Sources include Sulo, Single Waste, Cleanaway, SUEZ, just wheelie bins and Perth Waste for two-wheel mobile bins

Table G1.2: Average dimension ranges for four-wheel bulk bins



Bin capacity	660L	770L	1100L	1300L	1700L
Height (mm)	1250	1425	1470	1480	1470
Depth (mm)	850	1100	1245	1250	1250
Width (mm)	1370	1370	1370	1770	1770
Approx footprint (m ²)	0.86–1.16	1.51	1.33–1.74	2.21	2.21
Approx weight (kg)	45	Not known	65	Not known	Not known
Approx maximum load (kg)	310	Not known	440	Not known	Not known

Dome or flat lid container

Sources include Sulo, Signal Waste, Cleanaway, SUEZ, Just Wheelie Bins and Perth Waste

Source: *Better Practice Guide For Resource Recovery In Residential Developments 2019, NSW Environmental Protection Authority*

APPENDIX: C.2 SIGNAGE FOR WASTE AND RECYCLING BINS

Waste signs

Signs and educational materials perform several functions including:

- informing residents why it is important to recover resources and protect the environment
- providing clear instructions on how to use the bins and services provided
- alerting people to any dangers or hazards within the bin storage areas.

All waste, recycling and organic bins should be Australian Standard colours and clearly and correctly labelled, such as by a sticker on the lid and/or the body of the bin.

Communal bin storage areas should be clearly signposted with signs outlining how to correctly separate waste into the bins provided. The local council responsible for waste services may be a good source of signs and posters and can advise on what signs are suitable.

Information on who to contact to find out more about the recycling and/or other resource recovery services in the building should also be displayed in communal areas, such as on a noticeboard.

The Planet Ark website also has resources available free of charge for use by businesses and councils. These signs can be found at businessrecycling.com.au/research/signage.cfm

Figure I1.1: Examples of waste wall posters (EPA supplied)



Figure I1.2: Examples of bin lid stickers (EPA supplied)



Source: *Better Practice Guide For Resource Recovery In Residential Developments 2019*, NSW Environmental Protection Authority

Problem waste signs

The EPA has also produced a range of images and signs that can be used for problem wastes, such as fluoro globes and tubes, household and car batteries, e-waste and smoke detectors. To access these resources, contact the NSW EPA. Some examples are shown below.

Figure I2.1: Problem waste signs



Safety signs

The use of safety signs for waste resource recovery rooms must comply with *AS1319 Safety signs for occupational environments*. Safety signs must be used to regulate and control safety related to behaviour, warn of hazards and provide emergency information, including fire protection information. Suitable signs should be decided for each development as required.

Figure I3.1: Example safety signs



Source: *Better Practice Guide For Resource Recovery In Residential Developments 2019*, NSW Environmental Protection Authority

APPENDIX: C.3 EXAMPLE COLLECTION VEHICLE INFORMATION

General

Appropriate heavy rigid vehicle standards should be incorporated into the road and street designs in new developments where onsite collections are proposed. Road and street designs must comply with relevant Acts, regulations, guidelines, and codes administered by Austroads, Standards Australia, NSW Roads and Maritime Services, WorkSafe NSW and any local council traffic requirements.

Applicants and building designers should consult with councils and other relevant authorities before designing new roads or streets and access points for waste collection vehicles to establish specific design requirements.

Table H4.1: Australian Standards for turning circles for medium and heavy rigid class vehicles

Vehicle class	Overall length (m)	Design width (m)	Design turning radius (m)	Swept circle (m)	Clearance (travel) height (m)
Medium rigid vehicle	8.80	2.5	10.0	21.6	4.5
Heavy rigid vehicle	12.5	2.5	12.5	27.8	4.5

Source: *Better Practice Guide For Resource Recovery In Residential Developments 2019*, NSW Environmental Protection Authority

Large collection vehicles

Waste collection vehicles may be side-loading, rear-loading, front-lift-loading, hook or crane lift trucks. Vehicle dimensions vary by collection service, manufacturer, make and model. It is not possible to provide definitive dimensions, so architects and developers should consult with the local council and/or contractors.

The following characteristics represent typical collection vehicles and are provided for guidance only. Reference to *AS2890.2 Parking facilities: off-street commercial vehicle facilities* for detailed requirements, including vehicle dimensions, is recommended.

Table B2.1: Collection vehicle dimensions

Vehicle type	Rear-loading	Side-loading*	Front-lift-loading	Hook truck	Crane truck
Length overall (m)	10.5	9.6	11.8	10.0	10.0
Width overall (m)	2.5	2.5	2.5	3.0	2.5
Travel height (m)	3.9	3.6	4.8	4.7	3.8
Operational height for loading (m)	3.9	4.2	6.5	3.0	8.75
Vehicle tare weight (t)	13.1	11.8	16.7	13.0	13.0
Maximum payload (t)	10.0	10.8	11.0	14.5	9.5
Turning circle (m)	25.0	21.4	25.0	25.0	18

* The maximum reach of a side arm is 3 m.

Sources: JJ Richards, SUEZ, MacDonald Johnson, Cleanaway, Garwood, Ros Roca, Bingo and Edbro. Figures shown represent the maximum dimensions for each vehicle type.

Rear-loading collection vehicles

These vehicles are commonly used for domestic waste collections from MUDs and RFBs and sometimes for recycling. They can be used to collect waste stored in mobile bins or bulk bins, particularly where bins are not presented at the kerbside. They are also used for collecting bulky waste.

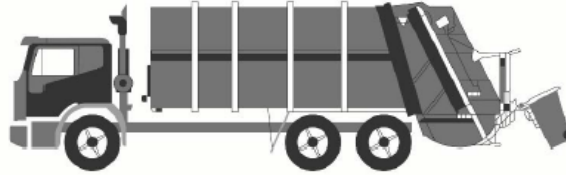

Rear-loading waste collection vehicle

Side-loading collection vehicles

This is the most commonly used vehicle for domestic waste, recycling and organics collections. It is only suitable for collecting mobile bins up to 360L in capacity.

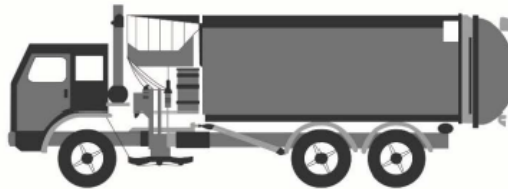

Side-loading waste collection vehicle

Front-lift-loading collection vehicles

These vehicles are commonly used for collecting commercial and industrial waste. They can only collect specially designed front-lift bulk bins and not mobile bins.



Front-lift-loading waste collection vehicle

Small collection vehicles

Typically, councils and their contractors operate with large collection vehicles (heavy rigid class vehicles) because they carry greater payloads and allow for more cost-effective collection services. Some councils, or their contractors, may have smaller collection vehicles in their fleet. Early discussion with the council is important to confirm this, but it should not be assumed that the council will have access to small collection vehicles.

The waste management systems and the location of the collection point should always be designed so that the council can provide the standard domestic waste service.

Source: *Better Practice Guide For Resource Recovery In Residential Developments 2019*, NSW Environmental Protection Authority

APPENDIX D: SECONDARY WASTE MANAGEMENT PROVISIONS

APPENDIX: D.1 EXAMPLE HANDHELD BIN MOVERS

moveXX
smart electric tugs

MOVEXX T2500
BIN MOVER BATTERY ELECTRIC

MoveXX T2500 Tow Tug is an extremely user friendly battery powered mobile towing unit that is ideal for applications where trolleys and rolling objects need to be moved from one place to another simply, efficiently and without physical effort. Some standard features included are: battery indicator, on board battery charger, battery, adjustable handle, dual speed and electric brake.

These units are fitted with an electromagnetic brake system for use on ramps and slopes

Features

- Electromagnetic brake for use on ramps and slopes
- Adjustable height handle



SPECIFICATION				
MODEL	DIMENSIONS (MM)	OPTIONS	PULL - PUSH CAPACITY (KG)	BATTERY
T2500-D	511 (w) x 757 (l)	* Centre mount 2x 240 lt. wheelie bin attachment	2500	AGM batteries 2x 85AH up to 8 hrs continuous operation
TOWING CAPACITY - ON FLAT GROUND (all models)			TOWING CAPACITY - SLOPE (all models)	
Towing up to 4x 660 lt. Wheelie Bin			Towing up to 2x 660 lt. Wheelie Bin Up / Down maximum 25% (1:4 slope)	
Towing up to 4x 1100 lt. Wheelie Bin			Towing up to 1x 1100 lt. Wheelie Bin Up / Down maximum 25% (1:4 slope)	
**Electromagnetic brake for use on ramps and slopes				



Please Note: This is an example only – please contact supplier for specific recommendations.

Source: Sitecraft - www.sitecraft.net.au

APPENDIX: D.2 EXAMPLE SEATED BIN MOVERS



MOTREC MT180

36V BATTERY ELECTRIC BIN MOVER

This hardworking tow device delivers outstanding performance. With its efficient motor and 4,500kg push-pull capacity. The MT180 is ideal for moving bin trailer also narrow enough to fit through most door openings. From its all-steel construction to its all-wheel braking, this tow tractor is built for years of heavy use in total comfort and safety. All this combined with superior AC technology makes short work of tough requests.

Features

- Front & rear brakes
- Pneumatic Tyres
- Comfortable ergonomic adjustable seat
- Complete with headlight, break lights, tailing lights & horn



SPECIFICATION				
MODEL	DIMENSIONS (MM)	OPTIONAL EXTRAS	PULL - PUSH CAPACITY (KG)	BATTERY
MT180 36V	760 (w) x 2030 (l) x 1160 (h)	Flashing light on pole Conditional registration kit Cabin includes windscreen Weather Curtains	4500	48V TPPL battery pack, 157AH
TOWING CAPACITY - ON FLAT GROUND / SLOPE (all models) (all models)				
Towing up to 5x 660 lt. Wheelie Bin Up / Down maximum 25% (1:4 slope)				
Towing up to 4x 1100 lt. Wheelie Bin Up / Down maximum 25% (1:4 slope)				



Please Note: This is an example only – please contact supplier for specific recommendations.

Source: Sitecraft - www.sitecraft.net.au

APPENDIX: D.3 EXAMPLE BIN TRAILERS



BIN TRAILER WITH ALUMINUM RAMP

Bin trailer suitable for moving 240lt, 660lt and 1,100lt bins including a 1200mm rear ramp complete with locking latches and gas strut assist. Height draw bar fitted with a jockey wheel large pneumatic tyres with precision bearing hubs



SPECIFICATION

MODEL	DIMENSION (MM)	SUITABLE FOR MOVING	PART NUMBERS	REAR RAMP DIMENSION (MM)
4x Bins Trailer	Internal - 1560 (l) x 1200 (w)	4x 240lt. Wheelie Bin	78811604	1200mm rear ramp complete with positive locking and gas strut assist
	External - 2300 (l) x 1500	2x 660lt. Wheelie Bin		
		1x 110lt. Wheelie Bin		
6x Bins Trailer	Internal - 2350 (l) x 1200 (w)	6x 240lt. Wheelie Bin	78811065	1200mm rear ramp complete with positive locking and gas strut assist
	External - 3100 (l) x 1500 (w)	3x 660lt. Wheelie Bin		
		2x 1100lt. Wheelie Bin		
8x Bins Trailer	Internal - 3200 (l) x 1200 (w)	8x 240lt. Wheelie Bin	78811066	1200mm rear ramp complete with positive locking and gas strut assist
	External - 3900 (l) x 1500 (w)	4x 660lt. Wheelie Bin		
		3x 1100lt. Wheelie Bin		
10x Bins Trailer	Internal - 3900 (l) x 1200 (w)	10x 240lt. Wheelie Bin	78811067	1200mm rear ramp complete with positive locking and gas strut assist
	External - 4600 (l) x 1500 (w)	5x 660lt. Wheelie Bin		
		4x 1100lt. Wheelie Bin		

OPTIONS

- Full registration
- Upgrade Includes : Lights | Wiring | Suspension | aaa Tyres | Compliance Plate

Please Note: This is an example only – please contact supplier for specific recommendations.

Source: Sitecraft - www.sitecraft.net.au

APPENDIX: D.4 EXAMPLE BIN TOWING ATTACHMENTS



UNIVERSAL BIN TOWING ATTACHMENTS

SUITE 660LT / 1100LT WHEELIE BINS

PARTS & FEATURES

Front Only - Part Number: 78811672

- Suit Sulo & Otto 600lt / 1100lt MGBs
- Spring loaded draw bar folds up
- No drilling of holes in the bin required
- Solidly fixed to the base of the bin using the castor mounting bolts
- Passivated zinc finish for long life
- Correct Rear Fixed or Directional Lock castors should be used

Rear Only - Part Number: 78811673

- Suit Sulo & Otto 600lt / 1100lt MGBs
- No drilling of holes in the bin required
- Solidly fixed to the base of the bin using the castor mounting bolts
- Passivated zinc finish for long life
- Correct Rear Fixed or Directional Lock castors should be used

For Steel Bin Front Only - Part Number: 78811781

- Suit Sulo & Otto 600lt / 1100lt MGBs
- No drilling of holes in the bin required
- Solidly fixed to the base of the bin using the castor mounting bolts
- Passivated zinc finish for long life
- Correct Rear Fixed or Directional Lock castors should be used

Direction Lock : 53191001

- Suit Sulo & Otto 600lt / 1100lt MGBs
- No drilling of holes in the bin required
- Solidly fixed to the base of the bin using the castor mounting bolts
- Passivated zinc finish for long life
- Correct Rear Fixed or Directional Lock castors should be used



Please Note: This is an example only – please contact supplier for specific recommendations.

Source: Sitecraft - www.sitecraft.net.au

APPENDIX: D.5 EXAMPLE BIN LIFTER FOR 240L BINS

versatip

Versatip Bin Tipper – 1500mm Tip



Specifications

Product Code	69121009
Product Name	1500mm Tip – Battery Powered
Capacity (kg)	250
Height (mm)	2085
Length (mm)	1330
Power Source	Battery Powered
Tipping Height (mm)	1500
Width (mm)	990

Please Note: This is an example only – please contact supplier for specific recommendations.

Source: Elephants Foot Equipment - www.elephantsfoot.com.au/equipment/

APPENDIX: D.6 EXAMPLE SOURCE SEPARATION RECEPTACLES

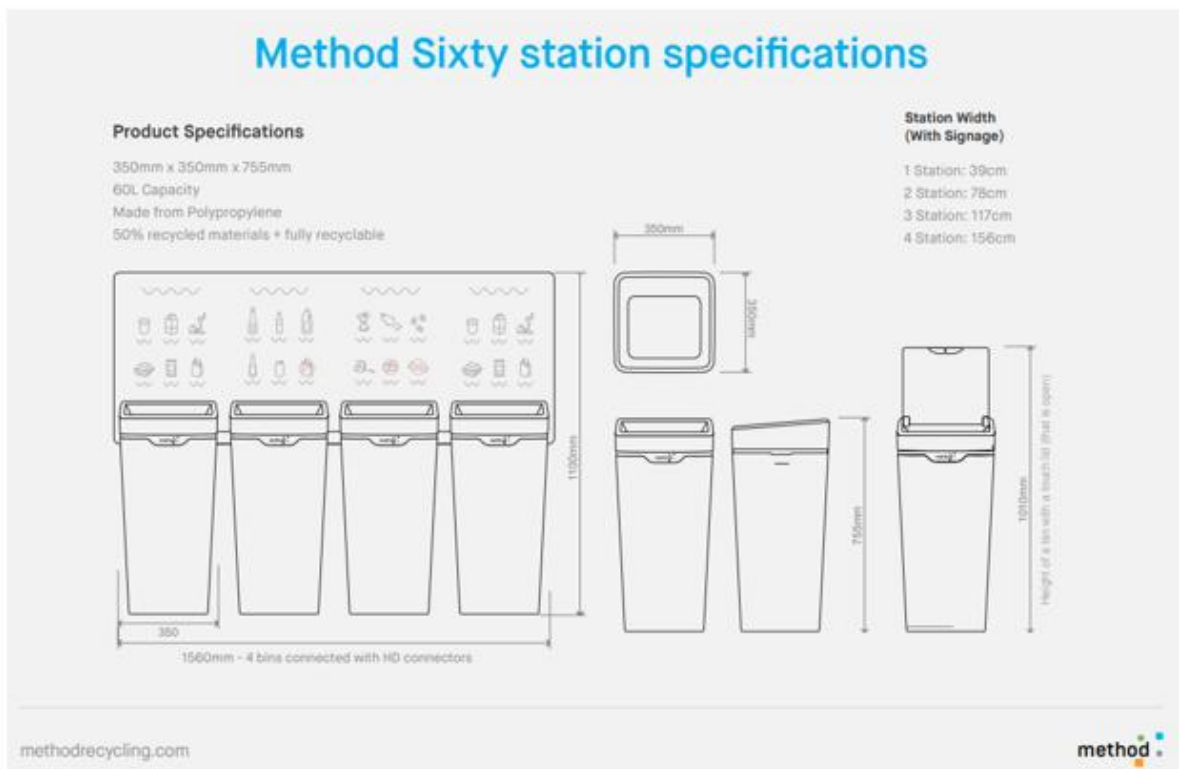
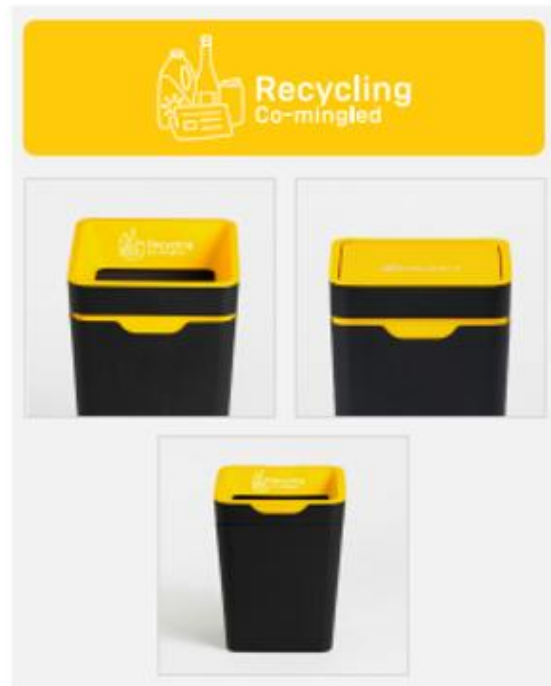
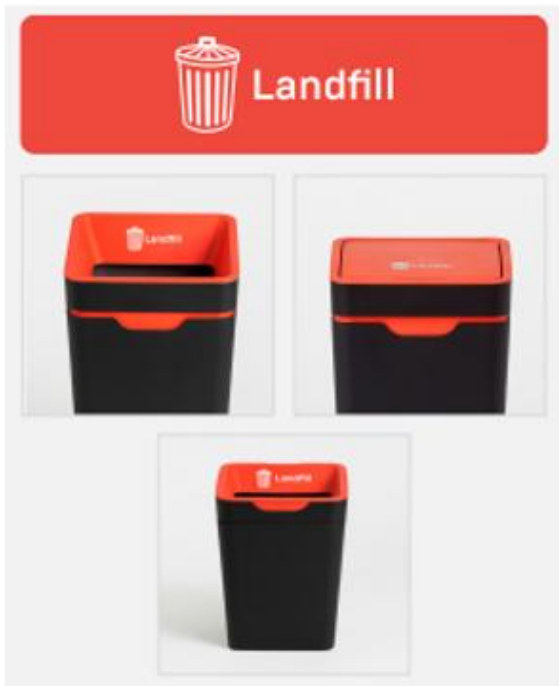

Source: Method Recycling - www.methodrecycling.com