

WATERLOO METRO QUARTER OVER STATION DEVELOPMENT

Environmental Impact Statement
Appendix H – BCA and DDA Assessment Report

SSD-79307746 Central Precinct

Detailed State Significant Development
Development Application

Prepared for **WL Developer Pty Ltd**

18th September 2025

BCA & DDA Assessment Report

Waterloo Metro Quarter Development
Building 2

Prepared for:

WL Developer

Revision 3

19 September 2025

Reference: S250130



bplusg.com.au

Liability limited by a scheme approved under Professional Standards Legislation.

Executive Summary

This report contains an assessment of the referenced architectural documentation for the proposed construction of Building 2 at Waterloo Metro Quarter Development against the deemed-to-satisfy provisions of the Building Code of Australia 2022 Amendment 2.

Arising from the assessment, key compliance issues have been identified that require further resolution, either by way of fire engineered Performance Solutions or plan amendments prior to the building approval.

Notwithstanding the above, it is considered that the proposed development can readily achieve compliance.

A. Matters requiring fire safety engineered Performance Solutions:

+ BCA (DtS) Clause	+ Description
1. C3D8	Building 2 is a United Building with Waterloo Metro Station & Buildings 1A & 1B. It is proposed to consider horizontal fire separation (at the Metro Station roof) in lieu of vertical fire wall separation to consider them as separate buildings.
2. C3D9 and C3D10	To rationalise the applicable FRL for separation of classification on the ground floor.
3. C3D15	The total length of public corridors on L3-L23 is 70m in lieu of 40m without smoke proof walls and doors.
4. C4D12 & Spec 5	To rationalise the bounding construction requirements between rooms and the corridor on level 3 and 24 due to there being no SOU's on the storey.
5. Spec 5	To potentially rationalise the ground floor FRL requirements due to the class 6 classification.
6. Spec 5	To rationalise the method of vertical fire separation at the slab edge and horizontal fire separation where fire walls meet the external wall.
7. D2D3	Note: FRNSW Fire Safety in Early Childhood Centres require a 'dedicated fire-isolated exit'. We note that the dedicated exit is non-fire-isolated and this should be addressed in the fire engineering assessment.
8. D2D4	The main egress stairway from the Childcare is not fire-isolated.
9. D2D4	To potentially allow the second exit from the level 25 plant floor to be an AS 1657 exit rather than a fire-isolated exit.
10. D2D5	<ul style="list-style-type: none">+ Level 4-23: Up to 13m to a point of choice from SOU doorways.+ Level 25: Up to 28m to a single exit from the roof.
11. D2D12	<ul style="list-style-type: none">+ To allow the fire-isolated stairs to discharge into a covered area which is >6m from open space.+ To allow the fire-isolated exits to discharge past non-fire-rated external walls and unprotected openings on the basis that egress can occur in opposite directions.

+ BCA (DtS) Clause		+ Description
12.	D2D16	To rationalise needing to accommodate all occupants of the childcare centre on both sides of the horizontal exit considering the population is split between level 1 and 2.
13.	D3D27	Confirm method of re-entry for fire-isolated stairs. Typically dealt with as a performance solution to rationalise extent of intercoms.
14.	E1D2	+ The hydrant booster is not within sight of the main entry. + Fire services designer to verify any fire hydrant non-compliances, such as booster location and hydrant locations
15.	E1D3	Fire services designer to verify any fire hose reel non-compliances.
16.	E1D4	Fire services designer to verify any sprinkler non-compliances.
17.	E1D15	The fire control room does have direct access to the entrance of the building. The front entrance of the building is considered to be the residential and commercial lobbies.
18.	E2D4	Mechanical designer to verify if there are any other fire engineered performance solution required for stairway pressurisation.
19.	E2D6	To rationalise the zone smoke control system. Examples include pressure differentials between childcare and residential floors and basement and retail ground floor.
20.	NSW E2D16	To rationalise the air-handling shutdown and zone smoke control system to the class 9b childcare with consideration of the conflicting requirements.
21.	E4D9	We assume the cascade of the EWIS may be rationalised to ensure a cascade of the fire alarm does not extend to Buildings 1A & 1B based on alarm activation in Building 2.

B. BCA & Access matters requiring Performance Solutions:

+ BCA (DtS) Clause		+ Description
1.	D4D2 – accessible SOU's	To rationalise the requirements relating to accessible class 3 SOU's. The two potential options for the performance solution are: Option 1: 5x fully accessible rooms (i.e. wheelchair users) 14x accessible rooms to consider other accessible needs. Option 2: 3x fully accessible rooms (i.e. wheelchair users) 16x accessible rooms to consider other accessible needs with 5-7x rooms being readily adaptable.
2.	D4D4 – doorway circulation	The cot room in playroom 4 of the childcare centre does not achieve doorway circulation. Either provide or we can support as a performance solution.
3.	F4D4 – unisex facilities	To allow the childcare staff sanitary facilities to be unisex.
4.	F4D4 – childcare kitchen	The childcare kitchen area is not capable of facilitating supervision of children younger than 2 years hold.
5.	F4D5 – accessible WC	To allow no accessible sanitary facility to be provided on level 2 of the childcare centre.

C. Other matters requiring Performance Solutions by Others:

+ BCA (DtS) Clause	+ Description
6.	<p data-bbox="284 315 347 338">F3D5</p> <p data-bbox="496 315 1458 376">A performance solution report may be required to be prepared to Performance Requirement F3P1 in relation to weatherproofing of external walls.</p> <p data-bbox="496 387 1417 416">This may be through Verification Method F3V1, or an alternative suitable method.</p> <p data-bbox="496 427 1031 456">This will be required from the Façade Engineer.</p>

+ Contents

- Executive Summary2**

- A. Matters requiring fire safety engineered Performance Solutions:2
- B. BCA & Access matters requiring Performance Solutions:3
- C. Other matters requiring Performance Solutions by Others:4

- 1.0 Introduction7**
 - 1.1 Background.....7
 - 1.2 Purpose and Project Description7
 - 1.3 Aim8
 - 1.4 Project Team8
 - 1.5 Referenced Documentation9
 - 1.6 BCA Regulatory Framework9
 - 1.7 DDA Regulatory Framework.....9
 - 1.8 Relevant Version of the Building Code of Australia 11
 - 1.9 Compliance with the National Construction Code 11
 - 1.10 Limitations and Exclusions 13
 - 1.11 Report Terminology 14

- 2.0 Building Characteristics..... 16**
 - 2.1 Proposed Development 16
 - 2.2 Fire Compartment Floor Area Limitations 17
 - 2.3 Distance to Fire Source Features 17

- 3.0 BCA Assessment 18**

- 4.0 DDA, BCA Part D4 & AS1428.1-2021 Assessment..... 76**
 - 4.1 DDA, BCA, BCA Part D4 & AS 1428.1-2021 Assessment 76

- 5.0 Conclusion 108**

- + Appendix 1 – Fire Resisting Construction Requirements 110**

- + Appendix 2 – Fire Safety Measures 112**

+ Report Status

+ Date	19.09.25
+ Revision	3
+ Status	Concept Design / SSDA
+ Author	Jack Gunning
+ Reviewed	Michael Potts

Prepared by:



Jack Gunning
Assistant Building Surveyor
BM+G

Prepared and reviewed by:



Michael Potts
Director
BM+G
Building Surveyor-Unrestricted (NSW)
BDC No.: 2516

+ Revision History

+ Revision	0	+ Date	26.08.25
+ Status	Concept Design / SSDA		

+ Revision	2	+ Date	18.09.25
+ Status	Concept Design / SSDA – Updated as per Clients Comments		

+ Revision	3	+ Date	19.09.25
+ Status	Concept Design / SSDA – Updated as per Clients Comments		

1.0 Introduction

1.1 Background

BM+G Pty Ltd have been commissioned by WL Developer to undertake an assessment of Building 2 as part of the Waterloo Metro Quarter Development at Waterloo Metro Station against the relevant provisions of the Building Code of Australia 2022 Amendment 2 (BCA) and the Disability (Access to Premises – Buildings) Standards 2024.

This Report focuses solely on Building 2 from ground level to the top storey of the building. Refer to separate Reports for the assessment in relation to Building 1A & 1B & Building 1A & 1B basement.

1.2 Purpose and Project Description

This report has been prepared by BM+G on behalf of WL Developer Pty Ltd (the applicant) to accompany a State Significant Development Application (SSDA) for the detailed Central Precinct SSD (SSD-79307746), located within the Waterloo Metro Quarter (WMQ) at 150 Cope Street, Waterloo. This SSD will replace the previous detailed approval applying to the Central precinct.

This report has been prepared to respond to Item 5 of the Planning Secretary’s Environmental Assessment Requirements (SEARs) issued by Department of Planning, Infrastructure and Housing (DPHI) on 13 February 2025.

The figure below indicates the land to which this DA applies in relation to the overall WMQ site (shaded in Green).

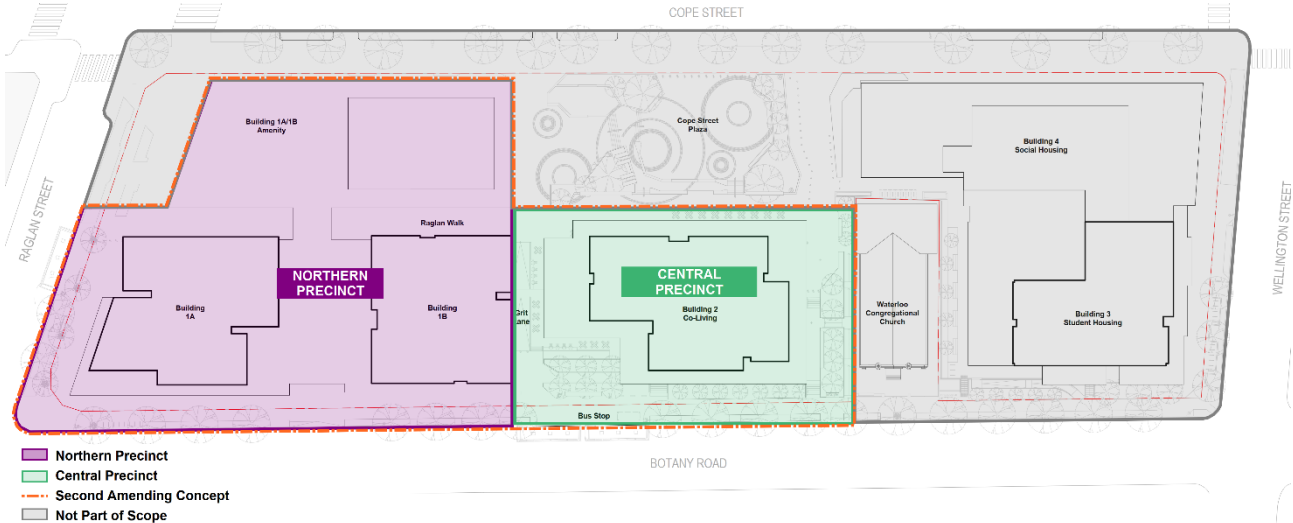

This application seeks consent for the design, construction and operation of a 26 storey (including plant level) mixed use building within the Central Precinct (the site) of the WMQ estate. The proposal comprises a Co-living housing tower above a three storey podium containing retail and community facility in the form of a childcare centre. Specially, the proposal comprises:

- + Ground level retail tenancies, community facility and childcare, co-living and shared basement access lobbies.
- + Community centre in the form of a childcare centre at Level 1 and Level 2.
- + A Co-living housing tower from Levels 3 to 24 comprising:
 - Self-contained co-living accommodation rooms across 20 levels, with capacity for around 500 rooms
 - Indoor and outdoor communal amenity at Levels 3 and 24

- Communal space also provided on each accommodation level;
- + Ground level vehicular access from Church Square shared zone to the shared basement, delivery of a pedestrian thoroughfare through the site, landscaping and public domain works.
- + Indicative building signage zones

This application is submitted for concurrent assessment with a DA to amend the Waterloo Metro Over Station Development (OSD) Concept DA (SSD 9393 (the Concept DA) - referred to as the Second Amending Concept DA. The Second Amending Concept DA seeks consent to modify the existing concept approval as it relates to the Northern and Central Precincts, by amending the building envelopes to redistribute floor space to suit a new mix of land uses. This Central Precinct SSD will be consistent with the Concept DA as amended.

Separately, a Detailed SSDA for the detailed design, construction and operation of the Northern Precinct (SSD-79307758) and a Section 4.55 Modification Application to modify the approved detailed Basement SSDA (SSD 10438), will be concurrently submitted with this application.

1.3 Aim

The aim of this report is to:

- + Undertake an assessment of the proposed development against the Deemed-to-Satisfy (DtS) provisions of the BCA.
- + Identify matters that require plan amendments in order to achieve compliance with the BCA.
- + Identify matters that are to be required to be addressed by Performance Solutions.
- + Enable the certifying authority to satisfy its statutory obligations under Clause 19(1) of the Environmental Planning and Assessment (Development Certification and Fire Safety) Regulation 2021.
- + Undertake an assessment of the proposed development against the Disability (Access to Premises – Buildings) Standards 2024.
- + Identify matters that require plan amendments in order to achieve compliance with the Access to Premises Standard and Part D4 of the BCA;

1.4 Project Team

The following BM+G team members have contributed to this Report:

- + **Jack Gunning** – Report Preparation (Assistant Building Surveyor)
- + **Michael Potts** – Project Director/Report Preparation (Director) | Building Surveyor-Unrestricted
- + **Brian Maguire** – Peer Review (Director) | Building Surveyor-Unrestricted

1.5 Referenced Documentation

The following documentation has been reviewed, referenced and/or relied upon in the preparation of this report:

- + Building Code of Australia 2022 (Amendment 2) (BCA).
- + The Guide to the Building Code of Australia 2022 (Amendment 2).
- + Architectural Plans prepared by Bates Smart numbered:

+ Drawing No.	+ Revision	+ Date
AR-DRG-DA000	01	
AR-DRG-DA010	01	
AR-DRG-DA100	01	
AR-DRG-DA101	01	
AR-DRG-DA102	01	
AR-DRG-DA103	01	
AR-DRG-DA104	01	
AR-DRG-DA105	01	
AR-DRG-DA124	01	
AR-DRG-DA125	01	
AR-DRG-DA126	01	

+ Drawing No.	+ Revision	+ Date
AR-DRG-DA130	01	
AR-DRG-DA131	01	
AR-DRG-DA135	01	
AR-DRG-DA136	01	
AR-DRG-DA137	01	
AR-DRG-DA140	01	
AR-DRG-DA141	01	
AR-DRG-DA145	01	
AR-DRG-DA190	01	
AR-DRG-DA191	01	

1.6 BCA Regulatory Framework

Pursuant to Section 19(1) of the Environmental Planning and Assessment (Development Certification and Fire Safety) Regulation 2021 all new building work must comply with the current BCA however the existing features of an existing building need not comply with the BCA unless upgrade is required by other clauses of the legislation.

1.7 DDA Regulatory Framework

The figure below represents the statutory framework addressing accessibility as noted in the below Act, Code Standards.

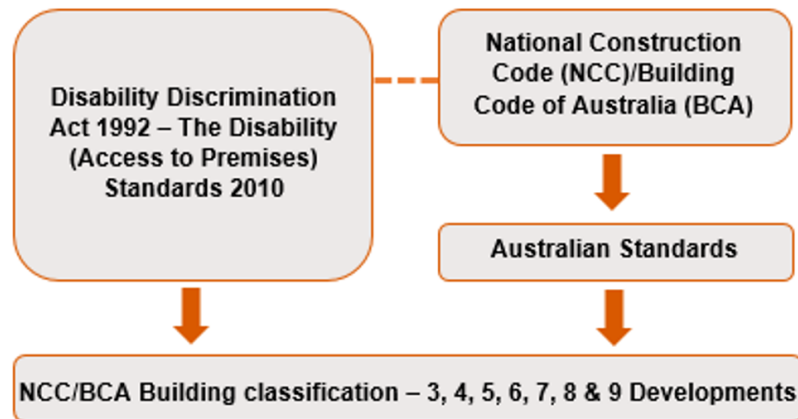

The Disability Discrimination Act 1992 (DDA) is Commonwealth legislation enacted in 1993 that seeks to ensure that all new building infrastructure, refurbishments, services and transport projects provide independent and equitable access. The DDA is a complaints based legislation administered by the Australian Human Rights Commission (AHRC).

Subordinate to the DDA are the Disability Standards, which include; Disability (Access to Premises – Buildings) Standards 2010, Disability Standards for Education 2005, and the Disability Standards for Accessible Public Transport 2002. These Disability standards refer back to the AS 1428 suite of standards and Building Code of Australia.

Since 2011, the Building Code of Australia has adopted the key accessibility provisions of the Disability (Access to Premises – Buildings) Standards 2010, with compliance with AS 1428.1 – 2009, AS 1428.4.1 – 2009, and AS 2890.6 – 2009 becoming mandatory. As such, compliance with the relevant sections of the BCA ensures compliance with the Disability (Access to Premises – Buildings) Standards 2010 and vicariously the DDA.

With respect to existing works, there are statutory upgrade requirements within the Disability (Access to Premises – Buildings) Standards 2010 that apply to all building works which require consent (including Crown building work). This relates to the upgrade of any 'affected part' of the building, which includes;

- + The principal pedestrian entry (i.e. entry door and ramp), and
- + The pathway / corridor / lift / ramp which form an accessible path of travel to any area of new work (note: only one accessible path of travel is required to any new part under this requirement).

Section 23 of the Disability Discrimination Act DDA 1992 states;

It is unlawful for a person to discriminate against another person on the ground of the other person's disability:

- *By refusing to allow the other person access to, or the use of, any premises that the public or a section of the public is entitled or allowed to enter or use (whether for payment or not); or*
- *In the terms or conditions on which the first-mentioned person is prepared to allow the other person access to, or the use of, any such premises; or*
- *In relation to the provision of means of access to such premises.*

The DDA Act 1992 is a complaints-based legislation whilst compliance with The Disability (Access to Premises) Standards 2010 affords some certainty regarding the minimum compliance requirements it does not prevent a claim being made under the DDA Act 1992. Whilst implementing the minimum compliance requirements under the Disability (Access to Premises) Standards 2010 and BCA will satisfy the minimum compliance requirements there is nothing preventing a greater degree of access than those minimum requirements specified.

Note: The below report also includes recommendations for best practice/non mandatory items for consideration by the project team stakeholders and as applicable have been identified in the below report in *italics*.

1.8 Relevant Version of the Building Code of Australia

Pursuant to Section 19 of the Environmental Planning and Assessment (Development Certification and Fire Safety) Regulation 2021 the proposed development is subject to compliance with the relevant requirements of the BCA as in force at the day on which the application for the Construction Certificate is made. The current version of the BCA is BCA 2022 (Amendment 2), which is currently in force.

Note: The adoption date of BCA 2025 has not been announced. If the application for the Construction Certificate is lodged after the date on which BCA 2025 comes into force, reassessment will be required.

Where the building is a multi-storey building and multiple Construction Certificates will be issued under the same development consent, the relevant version of the BCA may be 'locked in' based on the day in which the application is made for the Construction Certificate which involves the *entrance floor*.

1.9 Compliance with the National Construction Code

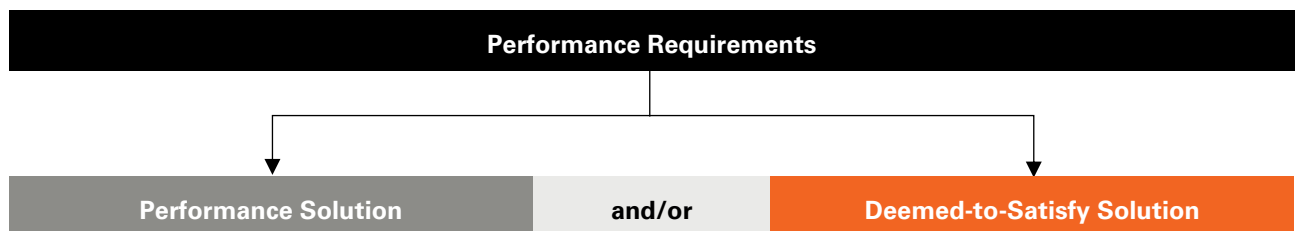

Compliance with the NCC is achieved by complying with:

- + the Governing Requirements of the NCC; and
- + the Performance Requirements.

Performance Requirements are satisfied by one of the following, as shown in the Figure below:

- + A Performance Solution.
- + A Deemed-to-Satisfy Solution.
- + A combination of the above two options.

Where a *Performance Requirement* is proposed to be satisfied by a *Performance Solution*, the following steps must be undertaken:

- + Prepare a performance-based design brief in consultation with relevant stakeholders.
- + Carry out analysis, using one or more of the Assessment Methods listed in A2G2(2), as proposed by the performance-based design brief.
- + Evaluation the results against the acceptance criteria in the performance-based design brief.
- + Prepare a final report that includes:
 - All Performance Requirements and/or Deemed-to-Satisfy provisions identified through A2G2(3) or A2G4(3) as applicable; and
 - Identification of all Assessment Methods used; and
 - Details of steps (a) to (c); and

- Confirmation that the Performance Requirement has been met; and
- Details of conditions or limitations, if any exist, regarding the Performance Solution.

1.10 Limitations and Exclusions

The limitations and exclusions of this report are as follows:

- + Whilst the BCA specifies a minimum standard of compliance with AS1428 (Parts 1-3) and Part D4 of the BCA for access and facilities for people with disabilities, compliance with such requirements may not necessarily preclude the possibility of a future complaint made under the DDA 1992. The DDA is a complaint based legislation and is presently not identified by the State Building Codes and Regulations. In this regard the building owner should be satisfied that their obligations under the DDA have been addressed.
- + No assessment has been undertaken with respect to the following areas of the NCC:
 - Structural
 - Weatherproofing
 - Waterproofing
 - Acoustic
 - Passive Fire Protection
 - Section J / ESD
 - Fire Safety Engineering
- + Where relevant to this development, it is assumed that these assessments will be undertaken by others.
- + This report does not constitute a detailed assessment of the architectural documentation against the requirements of Section J. It is understood that a suitably qualified consultant will be engaged to determine compliance in this regard.
- + **BM+G** has not undertaken an assessment of any Performance Solution Reports at the time of the preparation of this report.
- + The Report does not address matters in relation to the following Local Government Act and Regulations:
 - Work Health and Safety Act and Regulations.
 - Work Cover Authority requirements.
 - Water, drainage, gas, telecommunications and electricity supply authority requirements.
 - Disability Discrimination Act 1992.
- + **BM+G** Pty Ltd cannot guarantee acceptance of this report by Local Council, Fire & Rescue NSW or other approval authorities.
- + This report may not be relied upon under the provisions of the Design and Building Practitioners Act & Regulation for the purposes of issuing a Design Compliance Declaration.
- + No part of this document may be reproduced in any form or by any means without written permission from **BM+G** Pty Ltd. This report is based solely on client instructions, and therefore should not be used by any third party without prior knowledge of such instructions.
- + No Assessment has been undertaken unless it explicitly relates to the Access the Premises Standard of Part D4 of the BCA. As an example, AS1428.2-1992 has not been assessed.
- + Evacuation of occupants with a disability. No assessment has been undertaken to consider the equitable evacuation of all occupants.

1.11 Report Terminology

Building Code of Australia – Document published on behalf of the Australian Building Codes Board. The BCA is a uniform set of technical provisions for the design and construction of buildings and other structures throughout Australia and is adopted in NSW under the provisions of the Environmental Planning & Assessment Act & Regulation.

Climatic Zone – Means an area defined in Figure 2 and in Table 2 (of BCA Schedule 3) for specific locations, having energy efficiency provisions based on a range of similar climatic characteristics.

Construction Certificate – Building Approval issued by the Certifying Authority pursuant to Part 6 of the EP&A Act 1979.

Construction Type – The construction type is a measure of a building's ability to resist a fire. The minimum type of fire-resisting construction of a building must be that specified in Table C2D2 and Specification 5, except as allowed for:

- + certain Class 2, 3 or 9c buildings in C2D6; and
- + a Class 4 part of a building located on the top storey in C2D4(2); and
- + open spectator stands and indoor sports stadiums in C2D8.

Note: Type A construction is the most fire-resistant and Type C the least fire-resistant of the types of construction.

Deemed-to-Satisfy (DtS) Provisions of the BCA – Means the prescriptive provisions of the BCA which are deemed to satisfy the performance requirements.

Effective Height – The vertical distance between the floor of the lowest storey included in the calculation of rise in storeys and the floor of the topmost storey (excluding the topmost storey if it contains only heating, ventilating, lift, or other equipment, water tanks or similar service units).

Exit – Any, or any combination of the following if they provide egress to a road or open space:

- + An internal or external stairway.
- + A ramp.
- + A fire-isolated passageway.
- + A doorway opening to a road or open space.

Fire Compartment – The total space of the building; or when referred to in

- + The Performance Requirements – any part of a building separated from the remainder by barriers to fire such as walls and/or floors having an

appropriate resistance to the spread of fire with any openings adequately protected; or

- + The Deemed-to-Satisfy Provisions – any part of a building separated from the remainder by walls and/or floors each having an FRL not less than that required for a fire wall for that type of construction and where all openings in the separating construction are protected in accordance with the Deemed-to-Satisfy Provisions of the relevant part.

Fire Resistance Level (FRL) – The grading periods in minutes for the following criteria:

- + structural adequacy; and
- + integrity; and
- + insulation.

and expressed in that order.

Fire Source Feature (FSF) – The far boundary of a road adjoining the allotment; or a side or rear boundary of the allotment; or an external wall of another building on the allotment which is not a Class 10 building.

Health-Care Building – A building whose occupants or patients undergoing medical treatment generally need physical assistance to evacuate the building during an emergency and includes—

- + a public or private hospital; or
- + a nursing home or similar facility for sick or disabled persons needing full-time care; or
- + a clinic, day surgery or procedure unit where the effects of the predominant treatment administered involve patients becoming non-ambulatory and requiring supervised medical care on the premises for some time after the treatment.

Horizontal Exit – A required doorway between 2 parts of a building separated from each other by a fire wall.

National Construction Code Series (NCC) – The NCC was introduced 1 May 2011 by the Council of Australian Governments (COAG). The BCA Volume One (Class 2 to 9 Buildings) is now referenced as the National Construction Code Series Volume One — BCA.

Occupiable Outdoor Area – A space on a roof, balcony or similar part of a building:

- + that is open to the sky; and
- + to which access is provided, other than access only for maintenance; and
- + that is not open space or directly connected with open space.

Occupation Certificate (OC) – Building Occupation Approval issued by the Principal Certifying Authority pursuant to Part 6 of the EP&A Act 1979.

Open Space – A space on the allotment, or a roof or other part of the building suitably protected from fire, open to the sky and connected directly with a public road.

Performance-Based Design Brief (PBDB) – The process and the associated report that defines the scope of work for the performance-based analysis, the technical basis for analysis, and the criteria for acceptance of any relevant Performance Solution as agreed by stakeholders.

Performance Requirements of the BCA – A Building Solution will comply with the BCA if it satisfies the Performance Requirements. A Performance

requirement states the level of performance that a Building Solution must meet.

Compliance with the Performance Requirements can only be achieved by-

- + complying with the Deemed-to-Satisfy Provisions; or
- + formulating a Performance Solution which-
 - complies with the Performance Requirements; or
 - is shown to be at least equivalent to the Deemed-to-Satisfy Provisions; or
- + a combination of the above.

Performance Solution – A method of complying with the performance requirements other than by a Deemed-To-Satisfy Solution.

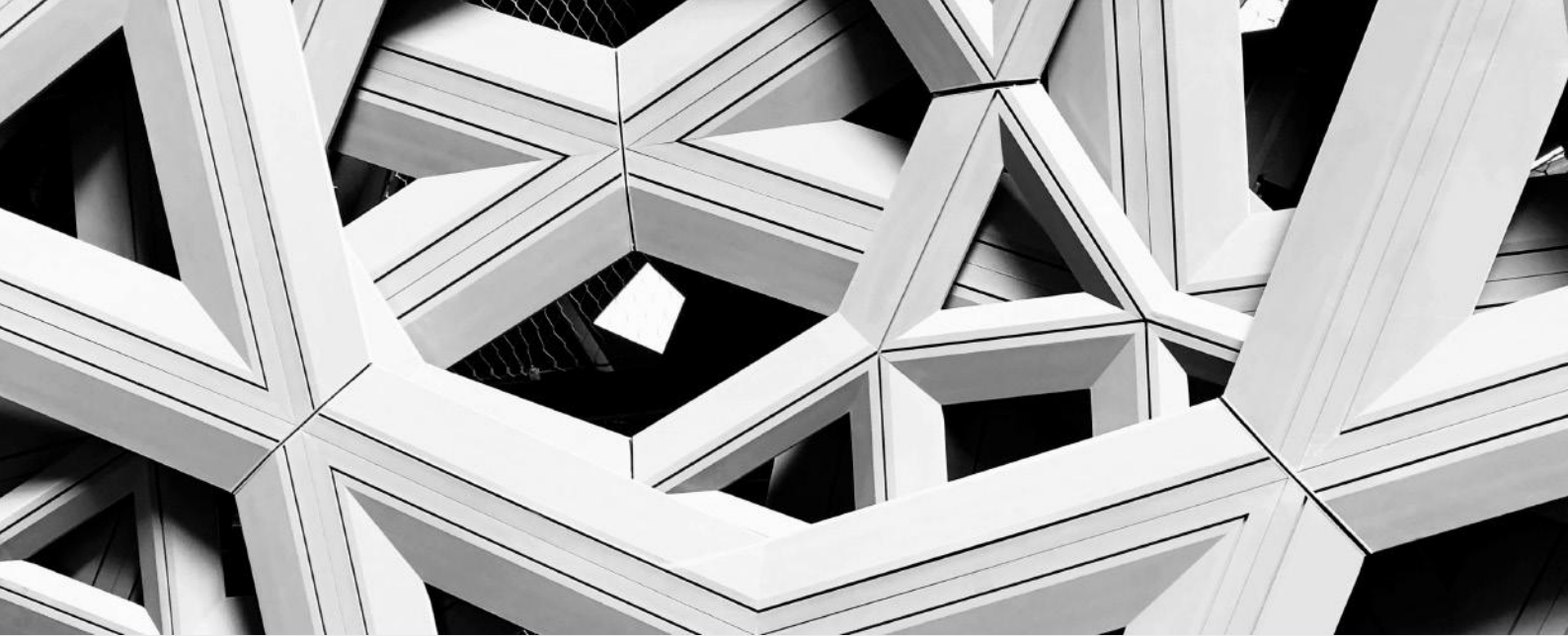

2.0 Building Characteristics

2.1 Proposed Development

The proposed development consists of the proposed Building 2 associated with the Waterloo Metro Quarter Development.

The building is classified as follows:

+ BCA Classifications:	Class 3 (Co-Living) – G, L3-L25 Class 6 (Retail) – ground floor Class 7a (Carpark) – basement levels Class 7b (Storage) – basement levels Class 9b (Childcare) – G-L2
+ Rise in Storeys: (Refer to Note 1)	28 Storeys (25 Storeys for Building 2 in isolation)
+ Storeys Contained: (Refer to Note 1)	30 Storeys (27 Storeys for Building 2 in isolation)
+ Type of Construction:	Type A Construction
+ Importance Level (Structural)	Importance Level 3
+ Sprinkler Protected Throughout	Yes
+ Effective Height	95.79m (effective height is taken from Bld 1)
+ Total Floor Area	~17,444m ²
+ Largest Fire Compartment	TBC
+ Climate Zone	Zone 5

Note 1: The proposed development is considered to be a united building with the Waterloo Station Box and Building 1A & 1B as per BCA Section A. It is united via the common basement carpark with Building 1A/1B and the station box due to a portion of Building 1A/1B being on top of the station box and connected via a link bridge. Note however, that the above BCA Classifications and characteristics are only of Building 2.

Note 2: The proposed use is 'co-living' based on the SEPP Housing definition. Based on our current understanding on how the building will be used (shared amenities and primary place of residency) we consider the use to be class 3.

2.2 Fire Compartment Floor Area Limitations

Maximum size of fire compartment/atrium is:

+ Classification		+ Type A	+ Type B	+ Type C
6, 7	Max. floor area	5,000m ²	3,500m ²	2,000m ²
	Max. volume	30,000m ³	21,000m ³	12,000m ³
9b	Max. floor area	8,000m ²	5,500m ²	3,000m ²
	Max. volume	48,000m ³	33,000m ³	18,000m ³

2.3 Distance to Fire Source Features

Based upon a review of the plans, it is noted that each elevation of the building is located within the following distances from fire source features on the site.

+ Elevation	+ Fire Source Feature	+ Distance
North	Raglan St	>6m from Building 2
East	Cope St Plaza / Allotment Boundary	To be advised – assumed to be >3m
West	Botany Road	>6m
South	103 Botany Rd	>6m

Note: Fire Source Feature (FSF) – The far boundary of a road adjoining the allotment; or a side or rear boundary of the allotment; or an external wall of another building on the allotment which is not a Class 10 building.

3.0 BCA Assessment

+ Legend

Complies	The referenced documentation show compliance with this clause / documentation has been submitted to BM+G that demonstrates compliance.
Compliance Readily Achievable	The referenced documentation does not include sufficient information to establish compliance with this clause however BM+G are satisfied that compliance is readily achievable. Compliance is to be verified during construction and/or installation certification (or other forms of documentation) should be provided to the Certifying Authority demonstrating that compliance has been achieved.
Further Information Required	The referenced plans do not show sufficient information to establish compliance with this clause. Further details, should be submitted with the application for the building approval.
Performance Solution	The referenced plans do not comply with this clause and a Performance Solution is required/proposed to demonstrate compliance with the Performance Requirements.
Does Not Comply	The proposal does not comply with this clause and redesign is required.
Note/Not Applicable	Provisions contained within this BCA clause are provided for guidance, or are to be read in conjunction with other BCA clauses.

+ Clause	+ Reference	+ Comment
Section B	Structure	
Part B1	Structural Provisions	
B1D3 Determination of Individual Actions	<p>Structural engineering details prepared by an appropriately qualified structural engineer to be provided to demonstrate compliance with Part B1 in relation to the new structural elements of the building.</p> <p>Design Statement from a Professional Engineer to be provided confirming that the design achieves compliance with the following is required at the time of Choose an item.. Application, inclusive of reference to the following Australian Standards (where relevant):</p> <ul style="list-style-type: none"> + AS 1170.0 – 2002 General Principles + AS 1170.1 – 2002, including certification for balustrading (dead and live loads) + AS 1170.2 – 2021, Wind loads + AS 1170.4 – 2007, Earthquake loads + AS 3700 – 2018, Masonry code 	<p>Compliance Readily Achievable:</p> <p>A compliance certificate from a Structural Engineer registered on the NER is required for all structural works at the completion of building works and prior to the issuance of a Occupation Certificate.</p> <p>Provision must be made in the design by all consultants (i.e. non-structural</p>

+ Clause	+ Reference	+ Comment
	<ul style="list-style-type: none"> + AS 3600 – 2018, Concrete code + AS 4100 – 2021, Steel Structures + AS 4600 – 2018, Cold formed steel. + AS 2047 – 2014, Windows in buildings + AS 1288 – 2021, Glass in buildings 	
B1D4 Determination of Structural Resistance of Materials	The structural resistance of materials and forms of construction must be determined in accordance with the requirements of this clause.	Compliance Readily Achievable: Detail and design certification to be provided at the Construction Certificate stage.
Section C		
Fire resistance		
Part C2		
Fire Resistance and Stability		
C2D2 Type of Construction Required	<p>The minimum type of fire-resisting construction of a building must be that specified in Table C2D2 and Spec. C2D2 except as allowed for in this clause.</p> <p>Table C2D2 does not apply to Class 2, 3 or 9c buildings classified in Part C2D6 or open spectator stands/indoor sports stadiums.</p>	<p>Note:</p> <p>Type A Construction applies to the building.</p> <p>Refer to Spec 5 of the BCA & APPENDIX 1 of this Report for the applicable FRLs to the project. Reference shall also be made to the project Fire Engineering Report.</p>
C2D4 Buildings of Multiple Classification	In a building of multiple classifications, the type of construction required for the building is the most fire-resisting type resulting from the application of Table C2D2 on the basis that the classification applying to the top storey applies to all storeys.	<p>Note:</p> <p>Type A Construction applies to the building.</p>
C2D9 Lightweight Construction	Lightweight construction must comply with Spec. 6 if used in a wall system that is required to have an FRL.	Compliance Readily Achievable: Detail to be included in the design to ensure compliance with this clause.
C2D10 Non-Combustible Building Elements	<p>In a building of Type A construction, the following building elements and their components must be non-combustible.</p> <ul style="list-style-type: none"> + External walls and common walls, including all components incorporated in them, including the façade covering, framing and insulation. + The flooring and floor framing of lift pits. + Non-loadbearing internal walls where they are required to be fire-resisting. <p>This clause contains provisions for combustible materials that may be used wherever a non-combustible material is required under the BCA, including:</p>	<p>Compliance Readily Achievable:</p> <p>Documentation is required to be provided as relevant to:</p> <ul style="list-style-type: none"> + Any external wall claddings. + Any framing or integral formwork systems. I.e. timber framing, sacrificial formwork, etc. + Any external linings or trims. I.e. external UPVC window linings, timber window blades, etc. + Any sarking or insulation contained within the wall assembly. <p>An External Wall Disclosure statement is to be provided, at</p>

+ Clause	+ Reference	+ Comment
	<ul style="list-style-type: none"> + Combustible elements permitted within the external wall under C2D10(4). + Materials, where comprised entirely of itself, which are deemed non-combustible under C2D10(5). + Materials which are permitted for use where non-combustible materials are required under C2D10(6). <p><i>Note: Sarking type materials that do not exceed 1mm in thickness and have a Flammability Index not greater than 5 are permitted to be installed with an external wall.</i></p>	<p>Detailed Design stage, which captures all elements within the external wall make-up along with supporting evidence of suitability.</p>
<p>C2D11 Early Fire Hazard Properties</p>	<p>The fire hazard properties of the outlined linings, materials and assemblies in a Class 2 to 9 building must comply with Spec. 7.</p> <p>Refer below to extracts from Tables S7C3 and S7C4 of Spec. 7. as relevant to wall, floor, and ceiling linings.</p> <p>For additional detailed requirements relating to additional building elements, refer to the relevant clause of Spec 7 as outlined below:</p> <ul style="list-style-type: none"> + Floor linings and coverings – S7C3 + Wall linings and ceiling linings – S7C4 + Air-handling ductwork – S7C5. + Lift Cars – S7C6. + Fire control rooms and fire-isolated exits – S7C7. + Fixed seating and proscenium curtains in Class 9b theatres, public halls and the like – S7C7. + Escalators, moving walkways, and non-required non-fire-isolated stairways and ramps – S7C7. + Sarking-type materials – S7C7. + Attachments to internal floors, walls, and ceilings – S7C7. + Other materials – S7C7. 	<p>Compliance Readily Achievable:</p> <p>A schedule of all wall, floor, and ceiling linings along with associated test reports are to be provided for review to ensure compliance with the fire hazard property requirements of the BCA. Noting:</p> <ul style="list-style-type: none"> + Minimum Group Numbers apply to wall and ceiling linings. AS 5637 test reports must be provided to determine compliance. + Minimum Critical Radiant Flux values apply to floor linings. AS ISO 9239.1 test reports must be provided to determine compliance.

+ Clause	+ Reference	+ Comment
----------	-------------	-----------

+ Table S7C3 of Specification 7 – Critical Radiant Flux of Floor Linings and Floor Coverings

+ Class of building	+ Building not fitted with a sprinkler system	+ Building fitted with a sprinkler system (other than a FPA101D or FPA101H system)	+ Fire-isolated exits and fire control rooms
Class 3, 6, 7 or 9b	2.2 kW/m ²	1.2 kW/m ²	2.2 kW/m ²

+ Table S7C4 of Specification 7 – Wall and Ceiling Lining Materials (Materials Groups Permitted)

+ Class of building	+ Fire-isolated exits and fire control rooms	+ Public corridors	+ Specific areas	+ Other areas
Class 3 Sprinklered	Walls: 1 Ceilings: 1	Walls: 1, 2, 3 Ceilings: 1, 2, 3	Walls: 1, 2, 3 Ceilings: 1, 2, 3	Walls: 1, 2, 3 Ceilings: 1, 2, 3
Class 6, 7 Sprinklered	Walls: 1 Ceilings: 1	Walls: 1, 2, 3 Ceilings: 1, 2, 3	Walls: 1, 2, 3 Ceilings: 1, 2, 3	Walls: 1, 2, 3 Ceilings: 1, 2, 3
Class 9b other than schools, Sprinklered	Walls: 1 Ceilings: 1	Walls: 1, 2 Ceilings: 1, 2	Walls: 1, 2, 3 Ceilings: 1, 2, 3	Walls: 1, 2, 3 Ceilings: 1, 2, 3

C2D14
Ancillary Elements

An ancillary element must not be fixed, installed or attached to the internal parts or external face of an external wall that is required to be non-combustible unless it is one of the following:

- + An ancillary element that is non-combustible.
- + A gutter, downpipe or other plumbing fixture or fitting.
- + A flashing.
- + A grate, grille or similar cover not more than 2m² in area associated with a building service.
- + An electrical switch, socket-outlet, cover plate or the like.
- + A light fitting
- + A required sign.
- + A sign other than one provided under (a) or (g) that—
- + achieves a group number of 1 or 2; and
 - does not extend beyond one storey; and
 - does not extend beyond one fire compartment; and
 - is separated vertically from other signs permitted under (h) by at least 2 storeys.
- + An awning, sunshade, canopy, blind or shading hood other than one provided under (a) that—
- + meets the relevant requirements of Table S7C7 as for an internal element; and
- + serves a storey—
 - at ground level; or

Compliance Readily Achievable:

Documentation is required to be provided as relevant to:

- + External signage
- + Window Shades
- + Decorative battens or the like
- + Any other element forming an ancillary element to the external wall.

An External Wall Disclosure statement is to be provided, at Detailed Design stage, which captures all elements attached to the external face, or internal parts of, the external wall make-up along with supporting evidence of suitability.

+ Clause	+ Reference	+ Comment
	<ul style="list-style-type: none"> - immediately above a storey at ground level; and + does not serve an exit, where it would render the exit unusable in a fire. + A part of a security, intercom or announcement system. + Wiring. + Waterproofing material installed in accordance with AS 4654.2 and applied to an adjacent floor surface, including vertical upturn, or a roof surface. + Collars, sleeves and insulation associated with service installations. + Screens applied to vents, weepholes and gaps complying with AS 3959. + Wiper and brush seals associated with doors, windows or other openings. + A gasket, caulking, sealant or adhesive directly associated with (a) to (o). 	
<p>C2D15 Fixing of bonded laminated cladding panels</p>	<p>In a building required to be of Type A or B construction, externally located bonded laminated cladding panels must have all layers of cladding mechanically supported or restrained to the supporting frame.</p> <p>An externally located bonded laminated panel need not comply with this requirement if it is one of the following:</p> <ul style="list-style-type: none"> + A laminated glass system. + Layered plasterboard product. + Perforated gypsum lath with a normal paper finish. + Fibrous-plaster sheet. + Fibre-reinforced cement sheeting. + A component of a garage door. 	<p>Compliance Readily Achievable: An External Wall Disclosure statement is to be provided, at Detailed Design stage, which captures all elements within the external wall make-up along with supporting evidence of suitability.</p>
<p>Part C2</p>	<p>Fire Compartmentation and Separation</p>	
<p>C3D3 General Floor Area Limitations</p>	<p>Limitations on the area and volume of fire compartments in Class 5 / 6 / 7 / 8 / 9 buildings as required by sub-clauses (a), (b) & (c) must be adhered to unless excepted by Clause C3D2 or C3D4.</p> <p><i>Note: These requirements do not apply to:</i></p> <ul style="list-style-type: none"> + A carpark protected by a sprinkler system (other than a FPAA101D or FPAA101H system) + An open deck car park + An open spectator stand. 	<p>Compliance Readily Achievable: Details of fire walls and compartmentation to be developed at Detailed Design stage.</p>

+ Clause	+ Reference	+ Comment
<p>C3D6 Class 9 Buildings</p>	<p>In a building containing a Class 9b early childhood centre—</p> <ul style="list-style-type: none"> + unless the Class 9b early childhood centre is the only use in the building, it must be separated from the remainder of the building by walls and/or floors with an FRL not less than that required for a fire wall; and + each storey must contain not less than 2 fire compartments. 	<p>Compliance Readily Achievable: Details of fire walls and compartmentation to be developed at Detailed Design stage.</p> <p>Level 1 and 2 requires a fire wall running east-west.</p>
<p>C3D8 Separation by Fire Walls</p>	<p><u>Construction-</u> A fire wall must be in accordance with the following:</p> <ul style="list-style-type: none"> + The fire wall has the relevant FRL prescribed by Spec. 5. + Unless permitted by Part C4, must not reduce the FRL prescribed by Spec. 5. + Building elements (other than roof battens of 75x50 or sarking-type material) must not pass through a fire wall unless the FRL of the wall can be maintained. <p><u>Separation of buildings-</u> A part of a building may be considered separate from the remainder of the building if separated by a fire wall in accordance with the following:</p> <ul style="list-style-type: none"> + The fire wall extends through all storeys and is carried through to the underside of the roof covering. <ul style="list-style-type: none"> - Where roofs of separate buildings are at different heights, the fire wall must extend to the underside of: <ul style="list-style-type: none"> - The higher roof, or >6m above the lower roof. - The lower roof if it has an FRL not less than that of the fire wall and no openings closer than 3m to any wall above the lower roof. - The lower roof if its covering is non-combustible and the lower part is sprinkler protected. <p><u>Separation of fire compartments-</u> A part of a building, separated from the remainder by a fire wall, may be treated as a separate fire compartment if the fire wall extends to the underside of:</p> <ul style="list-style-type: none"> + A floor having an FRL required for a fire wall; or + The roof covering. 	<p>Performance Solution: Building 2 is a United Building with Waterloo Metro Station & Buildings 1A & 1B. It is proposed to consider horizontal fire separation (at the Metro Station roof) in lieu of vertical fire wall separation to consider them as separate buildings.</p> <p>Compliance Readily Achievable: Details of fire walls and compartmentation to be developed at Detailed Design stage.</p>

+ Clause	+ Reference	+ Comment
C3D9 Separation of Classifications in the Same Storey	Each building element in that storey must have the higher FRL prescribed in Spec. 5 or have those parts of the building separated by a fire wall.	Performance Solution: To rationalise the applicable FRL for separation of classification on the ground floor.
C3D10 Separation of Classifications in Different Storeys	Parts of different classification that are situated one above the other in adjoining storeys must be separated as follows: + Type A construction – The floor between the adjoining parts must have an FRL of not less than that prescribed in Spec. 5 for the classification of the lower storey.	Performance Solution: To rationalise the applicable FRL for separation of classification on the ground floor.
C3D11 Separation of Lift Shafts	This clause applies to all classes of buildings and specifies the protection requirements for openings for lift shafts and lift landing doors. The requirements are set out in sub-clauses (1), (2) (3) & (4) which relate to openings in Type A, B and C construction. Also note the Deemed to Satisfy Provisions of Part C4.	Compliance Readily Achievable: Detail and design certification to be provided at the Construction Certificate stage.
C3D12 Stairways and Lifts in One Shaft	A stairway and lift must not be in the same shaft if either the stairway or the lift is required to be in a fire-resisting shaft.	Complies: The current plans show that stairways and lifts have been provided in separate shafts.
C3D13 Separation of Equipment	Equipment as listed below must be separated from the remainder of the building with construction that achieves an FRL of 120/120/120 (or that required by Spec 5, whichever is greater) and doorways being self-closing -/120/30 fire doors: + Lift motors and lift control panels; or + Emergency generators used to sustain emergency equipment operating in the emergency mode; or + Central smoke control plant; or + Boilers; or + A battery or batteries installed in the building that have a voltage exceeding 12 volts and a capacity exceeding 200kWh. + Separation of on-site fire pumps must comply with the requirements of AS 2419.1.	Compliance Readily Achievable: Details of fire walls and compartmentation to be developed at Detailed Design stage.
C3D14 Electricity Supply System	An electrical substation located within a building or a main switchroom which sustains emergency equipment, must: + Be separated from the building by construction achieving an FRL of 120/120/120; and	Compliance Readily Achievable: Details of fire walls and compartmentation to be developed at Detailed Design stage.

+ Clause	+ Reference	+ Comment														
	<ul style="list-style-type: none"> + Have any doorway protected with a self-closing fire door achieving an FRL of - /120/30. + Electrical conductors within a building must be protected in accordance with sub-clause (3). 															
C3D15 Public Corridors in Class 2 and 3 Buildings	A public corridor, if more than 40m in length, must be divided at intervals of not more than 40m with smoke proof walls complying with SC11C2	Performance Solution: The total length of public corridors on L3-L23 is 70m in lieu of 40m without smoke proof walls and doors.														
Part C4	Protection of Openings															
C4D2 Application of Part	Openings listed in C4D2(1) need not comply with the Deemed-to-Satisfy Provisions of Part C4.	Note: As the project falls under NCC 2022 Amendment 2, all fire rated products must be tested to AS 1530.4 – 2014. Test Reports to previous revisions of the standard will no longer be accepted.														
C4D3 Protection of Openings in External Walls	<p>Openings in an external wall required to have an FRL must be protected in accordance with C4D5 if the opening is less than:</p> <ul style="list-style-type: none"> + 3m from a side or rear boundary; or + 6m from the far boundary of a road, river, lake or the like adjoining the allotment if not located at or near ground level; or + Less than 6m from another building on the allotment that is not Class 10. 	<p>Further Information Required:</p> <p>Confirm where the allotment boundary is in relation to the eastern elevation of the Building. We understand the external wall is >3m from the allotment boundary.</p>														
C4D4 Separation of External Walls and Associated Openings in Different Fire Compartments	<p>The distance between parts of external walls and any openings within them in different fire compartments separated by a fire wall must be at least that set out in Table C4D4 unless-</p> <ul style="list-style-type: none"> + Those parts of each wall have an FRL of at least 60/60/60; and + Any openings protected in accordance with C4D5. <p>Method of measurement between adjoining fire compartments is set out below: -</p> <table border="1"> <thead> <tr> <th>+ Angle between walls</th> <th>+ Min. Distance</th> </tr> </thead> <tbody> <tr> <td>0° (walls opposite)</td> <td>6m</td> </tr> <tr> <td>More than 0° to 45°</td> <td>5m</td> </tr> <tr> <td>More than 45° to 90°</td> <td>4m</td> </tr> <tr> <td>More than 90° to 135°</td> <td>3m</td> </tr> <tr> <td>More than 135° to 180°</td> <td>2m</td> </tr> <tr> <td>0° or more</td> <td>Nil</td> </tr> </tbody> </table>	+ Angle between walls	+ Min. Distance	0° (walls opposite)	6m	More than 0° to 45°	5m	More than 45° to 90°	4m	More than 90° to 135°	3m	More than 135° to 180°	2m	0° or more	Nil	<p>Compliance Readily Achievable:</p> <p>Details of fire walls and compartmentation to be developed at Detailed Design stage.</p>
+ Angle between walls	+ Min. Distance															
0° (walls opposite)	6m															
More than 0° to 45°	5m															
More than 45° to 90°	4m															
More than 90° to 135°	3m															
More than 135° to 180°	2m															
0° or more	Nil															
C4D5	Where protection is required, doorways, windows and other openings must be protected as follows:	<p>Compliance Readily Achievable:</p> <p>Details to be developed at detailed design stage.</p>														

+ Clause	+ Reference	+ Comment
<p>Acceptable Methods of Protection</p>	<ul style="list-style-type: none"> + Doorways – <ul style="list-style-type: none"> – Internal or external wall-wetting sprinklers as appropriate used with doors that are self-closing or automatic closing; or – -/60/30 fire doors that are self-closing or automatic closing. + Windows – <ul style="list-style-type: none"> – Internal or external wall-wetting sprinklers as appropriate used with windows that are automatic closing or permanently fixed in the closed position; or – -/60/- automatic closing fire shutters. + Other openings – <ul style="list-style-type: none"> – Excluding voids – internal or external wall-wetting sprinklers, as appropriate; or – Construction having FRL not less than -/60/-. 	
<p>C4D6 Doorways in Fire Walls</p>	<p>Openings in fire walls, that are not part of a horizontal exit, must be protected in accordance with one of the methods set out in this clause.</p> <p>Doorways in fire walls, that are not part of a horizontal exit, must:</p> <ul style="list-style-type: none"> + In aggregate door width, not exceed ½ of the length of the fire wall. + Be protected by fire doors achieving the FRL required for the wall in accordance with Spec. 5 for Type A Construction. + Be self-closing or automatically close on the activation of a smoke detector and applicable sprinkler system. 	<p>Compliance Readily Achievable: Details to be included into the design where applicable.</p>
<p>C4D7 Sliding Fire Doors</p>	<p>If doorway in a fire wall is fitted with a sliding fire door which is held in the open position whilst the building is occupied, the door must:</p> <ul style="list-style-type: none"> + Be held open with an electromagnetic device, which upon de-activation, must close the door in not less than 20 seconds. + Fail-safe to the closed position. + Be provided with an audible warning device and a red flashing warning device on each side of the doorway. + Signs must be installed on each side of the doorway over the opening stating: ‘WARNING – SLIDING FIRE DOOR’ 	<p>Note: We understand there are no sliding fire doors proposed in the design.</p>

+ Clause	+ Reference	+ Comment
	<p>(Capital letters. 50mm high. Colour contrasting with background)</p> <ul style="list-style-type: none"> + Be de-activated by heat or smoke detector activation and the activation of an applicable sprinkler system. 	
<p>C4D8 Protection of Doorways in Horizontal Exits</p>	<p>A doorway that is part of a horizontal exit must be protected by:</p> <ul style="list-style-type: none"> + A fire door with an FRL as required for the wall under Spec. 5, except that the door must have an insulation rating of at least 30; or; + Class 7 – Two fire doors, one on each side of the doorway, achieving ½ the FRL required for the wall under Spec 5, except that the door must have an insulation level of at least 30. + Be self-closing, or automatic-closing activated by heat or smoke detector activation and the activation of an applicable sprinkler system. 	<p>Compliance Readily Achievable: Details to be included into the design where applicable.</p>
<p>C4D9 Openings in Fire Isolated Exits</p>	<p>Doorways that open to fire-isolated exits (excluding those that open to a road or open space), must be protected by -/60/30 self-closing, or automatic closing fire doors.</p> <p>A window in an external wall of a fire-isolated exit must be protected in accordance with C4D5 if it is exposed to and within 6m of another opening in wall of the same building (excludes openings in the same fire-isolated exit).</p>	<p>Compliance Readily Achievable: Detail to be included in the design where applicable.</p>
<p>C4D10 Service Penetrations in Fire Isolated Exits</p>	<p>Fire isolated exits may only be penetrated by:</p> <ul style="list-style-type: none"> + Electrical wiring permitted by D3D8 (6). + Ducting associated with a pressurisation system. <ul style="list-style-type: none"> – is constructed of material having an FRL of not less than -/120/60 where it passes through any other part of the building; and – does not open into any other part of the building; or + Water supply and test drain pipes for fire services. 	<p>Compliance Readily Achievable: Ensure no services are provided within stairways unless permitted. Details to be developed for review.</p>
<p>C4D11 Openings in Fire Isolated Lift Shafts</p>	<p><u>Doorways</u> – Lift shafts required to be fire-isolated must be protected by -/60/- self-closing fire doors complying with AS1735.11.</p> <p><u>Lift Indicator Panels</u> – If exceeding 35,000mm², lift indicator panels must be backed by no less than FRL-/60/60 construction.</p>	<p>Compliance Readily Achievable: The entrance doorways to all lifts are required to be protected in accordance with this clause.</p>

+ Clause	+ Reference	+ Comment
<p>C4D12 Bounding Construction: Class 2, 3 and 4 Parts</p>	<p>A doorway in a Class 3 building must be protected if it provides access from a SOU to:</p> <ul style="list-style-type: none"> + A public corridor, lobby, or the like; or + A room not within a SOU; or + The landing of an internal non-fire-isolated required stairway; or + Another SOU. <p>If it provides access from a room not within a SOU to, the following doorways must be protected:</p> <ul style="list-style-type: none"> + A public corridor, lobby, or the like; or + The landing of an internal non-fire-isolated required stairway. <p><i>Protection</i> under this part refers to:</p> <ul style="list-style-type: none"> + Type A Construction: self-closing, -/60/30 fire door + In a Class 3 building where a path of travel does not offer a choice of travel in different directions to different exits and is located along an open balcony, landing, or the like and passes an external wall of- + Another SOU or a room not within a SOU, Then that external wall must- + Be constructed of concrete or masonry, or lined internally with a fire-protective covering. + Have any door fitted with a self-closing solid core door >35mm thick. + Having any windows or other openings protected in accordance with C4D5 or located >1.5m above finished floor level. 	<p>Performance Solution:</p> <p>To rationalise the bounding construction requirements between rooms and the corridor on level 3 and 24 due to there being no SOU's on the storey.</p> <p>Compliance Readily Achievable:</p> <p>Fire rating plans to be developed at reviewed at Design Development stage.</p>
<p>C4D13 Openings in Floors and Ceilings for Services</p>	<p>Where a service passes through:</p> <ul style="list-style-type: none"> + A floor required to have an FRL (integrity and insulation), or; + A ceiling required to have a resistance to the incipient spread of fire, <p>That service must be protected:</p> <ul style="list-style-type: none"> + In a building of Type A construction, by a shaft complying with Spec 5, and; + The performance of any <i>required</i> fire-protective floor covering must not be reduced by service penetrations. 	<p>Compliance Readily Achievable:</p> <p>Details to be included into the design.</p>
<p>C4D14 Openings in Shafts</p>	<p>In a building of Type A Construction, service shafts must be protected by:</p> <ul style="list-style-type: none"> + A fire door, hopper or access panel achieving FRL -60/30. 	<p>Compliance Readily Achievable:</p> <p>Details to be included into the design.</p> <p>Details to be provided of the base of the fire rating shaft serving the</p>

+ Clause	+ Reference	+ Comment
	<ul style="list-style-type: none"> + If in a sanitary compartment - a non-combustible door and frame achieving an FRL of -/30/30. + If the shaft is a garbage shaft – a non-combustible door or hopper. 	<p>garbage chute. A non-combustible hopper door required to be installed at the bottom of the chute.</p>
<p>C4D15 Openings for Service Installations</p>	<p>When a service penetrates a building element that is required to have an FRL with respect to integrity or insulation or a resistance to the incipient spread of fire, that penetration must:</p> <ul style="list-style-type: none"> + Be identical to a tested prototype assembly, tested in accordance with AS4072.1 and AS1530.4. + In the case of ventilating or air-conditioning ducts/equipment, the installation must comply with AS1668.1. 	<p>Compliance Readily Achievable: Detail of fire stopping details and design certification to be provided at the Construction Certificate stage.</p>
<p>C4D16 Construction Joints</p>	<p>Construction joints, spaces and the like in and between building elements required to be fire-resisting with respect to integrity and insulation must be protected in a manner-</p> <ul style="list-style-type: none"> + identical with a prototype tested in accordance with AS 1530.4 and AS 4072.1 to achieve the required FRL, or + that differs from a prototype in accordance with Section 4 of AS 4072.1 and achieves the required FRL. 	<p>Compliance Readily Achievable: Detail and design certification to be provided at the Construction Certificate stage.</p>
<p>C4D17 Columns Protected with Lightweight Construction to Achieve an FRL</p>	<p>A column protected by lightweight construction to achieve an FRL which passes through a building element that is required to have an FRL or a resistance to the incipient spread of fire, must be installed using a method and materials identical with a prototype assembly of the construction which has achieved the required FRL or resistance to the incipient spread of fire.</p> <p>The determination of the required FRL must be confirmed in a report from an Accredited Testing Laboratory in accordance with Spec. 1 and 2.</p> <p>The requirements of (1) do not apply where joints, spaces and the like between fire-protected timber elements are provided with cavity barriers in accordance with Spec. 9.</p>	<p>Compliance Readily Achievable: Detail and design certification to be provided at the Construction Certificate stage.</p>
<p>Part C Specifications</p>		

+ Clause	+ Reference	+ Comment
<p>Spec. 5 Fire-Resisting Construction</p>	<p>The new building works are required to comply with the requirements detailed within Spec 5 for Type A Construction.</p>	<p>Performance Solution:</p> <p>To potentially rationalise the ground floor FRL requirements due to the class 6 classification.</p> <p>To rationalise the method of vertical fire separation at the slab edge and horizontal fire separation where fire walls meet the external wall.</p> <p>To rationalise the bounding construction requirements between rooms and the corridor on level 3 and 24 due to there being no SOU's on the storey.</p> <p>Compliance Readily Achievable:</p> <p>Fire rating plans to be developed at reviewed at Design Development stage.</p>
<p>Spec. 12 Fire Doors and Smoke Doors</p>	<p><u>Fire doors</u> must comply with AS1905.1 and not fail the period specified for integrity in the required FRL due to glazed parts.</p> <p><u>Smoke doors</u> must be constructed to prevent the free passage of smoke from one side of the doorway to the other. If they are glazed, there must be minimal danger of a person being injured by walking into them. A smoke door must be constructed as follows-</p> <ul style="list-style-type: none"> + The door must swing in direction of egress, or both directions. + The leaves are capable of resisting smoke at 200°C for 30 minutes. Solid core leaves of minimum 35mm thick satisfy. + The leaves are fitted with smoke seals. + The leaves are normally in the closed position, or the leaves are closed automatically through interface with smoke detectors present on each side of the doorway no more than 1.5m horizontal distance from the doorway. In the event of a power failure, the leaves must fail-safe to the closed position. + The leaves return to the fully closed position after each manual opening. + Any glazing part complies with AS1288. If a glazed panel may be mistake for an unobstructed exit, identification via opaque construction must be present. 	<p>Compliance Readily Achievable:</p> <p>Details to be included into the design.</p> <p>Note: Based on FRNSW Position Statement, fire bolts in fire doors should be avoided.</p>

+ Clause	+ Reference	+ Comment
	<p>A required fire shutter or fire window must be identical with a tested prototype that has met the required FRL as well as installed in the same manner. If a metallic fire shutter is not prohibited by C4D6, a required fire shutter must be a steel shutter complying with AS 1905.2.</p>	
Section D Access and Egress		
Part D2 Provision for Escape		
D2D3 Number of Exits Required	<p>In addition to horizontal exits, following buildings/areas are required to be provided with two exits-</p> <ul style="list-style-type: none"> + Class 3 / 6 Each storey if the building has an effective height >25m. + Class 9- <ul style="list-style-type: none"> - Each storey in a Class 9b used as an early childhood centre. 	<p>Compliance Readily Achievable:</p> <p>All storeys have not less than 2 exits. In relation to L25 roof plant level, we understand the whole floor is open to the sky so it is not a 'storey' and only a single exit is required.</p> <p>Performance Solution:</p> <p>Note: FRNSW Fire Safety in Early Childhood Centres require a 'dedicated fire-isolated exit'. We note that the dedicated exit is non-fire-isolated and this should be addressed in the fire engineering assessment.</p>
D2D4 When Fire Isolated Exits are Required	<p>Class 3 Buildings – Every stairway or ramp serving as a required exit must be fire-separated unless it connects or passes by not more than:</p> <ul style="list-style-type: none"> + 3 consecutive storeys in a Class 2; or + 2 consecutive storeys in a Class 3. <p>One additional storey of any classification may be included if:</p> <ul style="list-style-type: none"> + It is only for the accommodation of motor vehicles or for other ancillary purposes; or + The building is sprinkler protected; or + The required exit does not provided access to or egress from the additional storey, and is fire and smoke separated. <p>Class 6 / 9 Buildings – Every stairway or ramp serving as a required exit must be fire-isolated unless –</p>	<p>Performance Solution:</p> <p>The main egress stairway from the Childcare is not fire-isolated.</p> <p>To potentially allow the second exit from the level 25 plant floor to be an AS 1657 exit rather than a fire-isolated exit.</p> <p>Compliance Readily Achievable:</p> <p>All other vertical exits are required to be fire-isolated exits.</p>
D2D5 Exit Travel Distances	<p>For Class 3 buildings:</p> <ul style="list-style-type: none"> + Maximum 6m to an exit or to a point of choice between alternative exits from sole-occupancy units; 	<p>Performance Solution:</p> <p>Level 4-23: Up to 13m to a point of choice from SOU doorways.</p> <p>Level 25: Up to 28m to a single exit from the roof.</p>

+ Clause	+ Reference	+ Comment
	<ul style="list-style-type: none"> + 20m from a single exit to open space or road when the storey is on the same level of egress from sole-occupancy units; + Maximum 20m to an exit or to a point of choice between alternative exits from any other part of the floor not in a sole-occupancy unit. <p>For Class 6 / 9b buildings:</p> <ul style="list-style-type: none"> + Maximum 20m to an exit or to a point of choice between alternative exits. + In a Class 6 building, the distance to a single exit serving a storey at the level of access to a road or open space may be increased to 30m. + Maximum distance to one of those exits is 40m. 	<p>Further Information Required:</p> <p>The following details are required to complete the travel distance assessment:</p> <ul style="list-style-type: none"> + The rooftop plant layout and location of second exit
<p>D2D6 Distances Between Alternative Exits</p>	<p>Exits that are required as alternative means of egress must be-</p> <ul style="list-style-type: none"> + Distributed as uniformly as practical within the storey served. + Located so that unobstructed access to 2 exits is available from all points. + Not less than 9m apart + Not more than <ul style="list-style-type: none"> - Class 2/3: 45m apart - Class 9a patient care: 45m - In all other cases – 60m. <p>Located so that alternative paths of travel do not converge <6m.</p>	<p>Compliance Readily Achievable:</p> <p>All storeys are readily able to achieve compliance subject to final door locations.</p>
<p>D2D7 Dimensions of Exits</p>	<p>In a required exit or path of travel to an exit the unobstructed height throughout must be not less than 2m, except the unobstructed height of any doorway may be reduced to not less than 1980mm.</p>	<p>Compliance Readily Achievable:</p> <p>Detail to be included in the design.</p>
<p>D2D8 Width of exits, paths of travel to exits and doorways</p>	<p>The unobstructed width of each required exit or path of travel to an exit, except for ladders provided in accordance with D2D21, D3D23 or I3D5, and doorways, must be not less than—</p> <ul style="list-style-type: none"> + 1m. <p>If the storey, mezzanine or open spectator stand accommodates more than 100 persons but not more than 200 persons, the aggregate unobstructed width of each required exit or path of travel to an exit, except for doorways, must be not less than—</p> <ul style="list-style-type: none"> + 1 m plus 250mm for each 25 persons (or part) in excess of 100; or 	<p>Further Information Required:</p> <p>Confirm the proposed retail populations.</p> <p>Compliance Readily Achievable:</p> <p>We note the childcare spaces will accommodate a total of 155 people including staff and children which will be evenly split over the two childcare levels. The current aggregate egress width shown on plan complies with the requirements of this clause.</p>

+ Clause	+ Reference	+ Comment
----------	-------------	-----------

If the storey, mezzanine or open spectator stand accommodates more than 200 persons, the aggregate unobstructed width of each required exit or path of travel to an exit, except for doorways, must be not less than—

- + 2 m plus 500mm for every 60 persons (or part) in excess of 200 persons if egress involves a change in floor level by a stairway or ramp with a gradient steeper than 1 in 12; or
- + in any other case, 2 m plus 500mm for every 75 persons (or part) in excess of 200.

Level 1: 67 children, 9 staff
 Level 2: 64 children, 14 staff

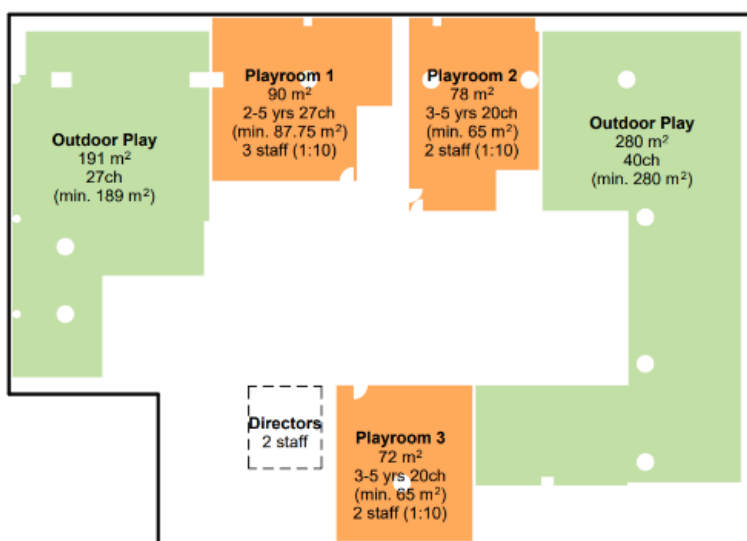

1 Level 01 - Indoor Outdoor Play
 1:200

+ Clause	+ Reference	+ Comment
----------	-------------	-----------

--

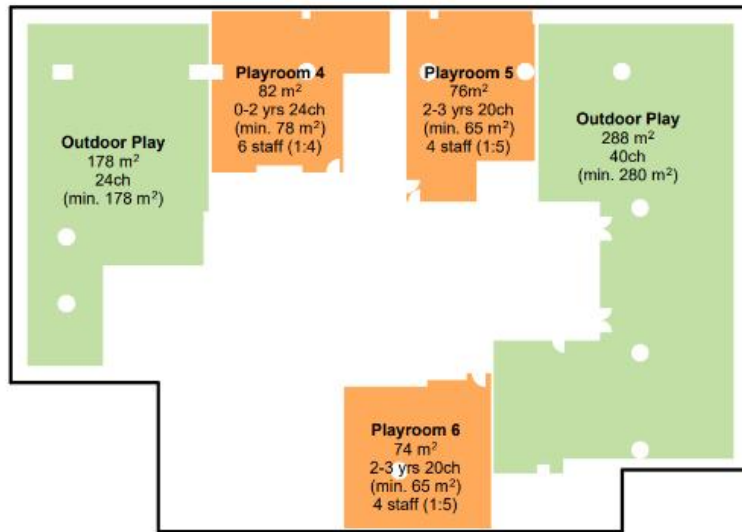

3 Level 02 - Indoor Outdoor Play
1 : 200

<p>D2D9 Width of doorway in exits or paths of travel to exits</p>
--

<p>In a required exit or path of travel to an exit, the unobstructed width of a doorway must be not less than—</p> <ul style="list-style-type: none"> + the unobstructed width of each exit provided to comply with D2D8(1), (2), (3) or (4), minus 250mm; or + in any other case except where it opens to a sanitary compartment or bathroom — 750mm wide.

<p>Compliance Readily Achievable: Detail to be included in the design.</p>

<p>D2D10 Exit width not to diminish in direction of travel</p>

<p>The unobstructed width of a required exit must not diminish in the direction of travel to a road or open space, except where the width is increased in accordance with D2D8(1)(b) or D2D9(a)(i).</p>

<p>Compliance Readily Achievable: Detail to be included in the design.</p>

<p>D2D11 Determination and measurement of exits and paths of travel to exits</p>

<p>For the purposes of D2D7 to D2D10 the following apply:</p> <ul style="list-style-type: none"> + The required width of a stairway or ramp in a required exit or path of travel to an exit must— <ul style="list-style-type: none"> – be measured clear of all obstructions such as handrails, projecting parts of barriers and the like; and – extend without interruption, except for ceiling cornices, to a height not less than 2m vertically above a line along the nosings of the treads or the floor surface of the ramp or landing. + To determine the aggregate unobstructed width, the number of persons accommodated must be calculated according to D2D18.
--

<p>Noted.</p>

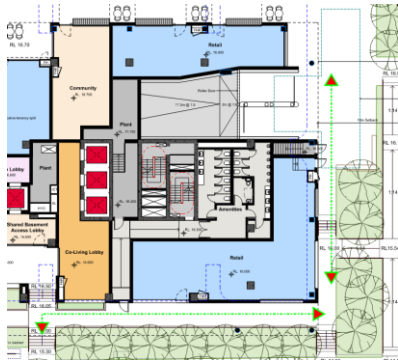
+ Clause	+ Reference	+ Comment
<p>D2D12 Travel via Fire Isolated Exits</p>	<p>A doorway from a room must not open directly into a stairway, passageway or ramp that is required to be fire-isolated unless it is from a public corridor/lobby, sole-occupancy unit occupying all of a storey or a sanitary compartment/airlock.</p> <p>Each fire isolated stairway or ramp must provide independent egress from each storey served and must discharge to –</p> <ul style="list-style-type: none"> + A road or open space; or + To a point in a space within the building that is only used for pedestrian movement or car parking that is open a minimum of 2/3 of its perimeter and from which a path of travel under 20m is available to a road or open space; or + A covered area that adjoins a road or open space, is open for a minimum of 1/3 of its perimeter, has an unobstructed height of at least 3m throughout and provides a path of travel the point of discharge to a road or open space within 6m. <p>In a fire-isolated ramp must be provided at any change in floor level less than 600mm. A ramp for changes of level in a fire isolated passageway is required in a Class 9 building.</p> <p>Where a path of travel from the point of discharge of a fire isolated exit necessitates passing within 6m of any part of an external wall of the same building, that part of the wall must have –</p> <ul style="list-style-type: none"> + an FRL of not less than 60/60/60; and + Any openings protected internally in accordance with BCA Clause C4D5, <p>For a distance of 3m above or below, as appropriate, the level of the path of travel, or for the height of the wall, whichever is the lesser.</p>	<p>Performance Solution:</p> <p>To allow the fire-isolated stairs to discharge into a covered area which is >6m from open space.</p> <p>To allow the fire-isolated exits to discharge past non-fire-rated external walls and unprotected openings on the basis that egress can occur in opposite directions.</p> 
<p>D2D15 Discharge From Exits</p>	<p>The path of travel to the road from a required exit leading to open space must have an unobstructed exit width of that of the required exit, or if larger, 1m.</p> <p>If the discharge point of the exit is at a different level from the road, a stairway or ramp achieving no more than 1:14 must be provided, except for a Class 9a where a ramp must be provided.</p> <p>The discharge point of alternative exits must be located as far apart as practical and be</p>	<p>Complies:</p> <p>All exits discharge to a path/public domain area which connects with the road.</p>

+ Clause	+ Reference	+ Comment
	suitably protected from vehicles potentially blocking the exit.	
D2D16 Horizontal Exits	<p>Horizontal exits must have a clear area on the side of the fire wall to which occupants evacuate no less than:</p> <p>+ 0.5m² per person in any other case.</p> <p>In a Class 9b Early Childhood Centre, the clear area required by this clause must accommodate all occupants.</p> <p>The clear area required by this clause must be connected to the horizontal exit by an unobstructed path that has at least the dimensions required for the horizontal exit and may include the area of the unobstructed path.</p>	<p>Performance Solution:</p> <p>To rationalise needing to accommodate <u>all</u> occupants of the childcare centre on both sides of the horizontal exit considering the population is split between level 1 and 2.</p> <p>Compliance Readily Achievable:</p> <p>Level 1 has 76 people. There is 38m² of available space to accommodate the occupants on each side of the horizontal exits.</p> <p>Level 2 78 people. There is 39m² of available space to accommodate the occupants on each side of the horizontal exits.</p>
D2D18 Number of Persons Accommodated	Outlines the number of persons accommodated in a storey as per Table D2D18 and NSW Table D2D18 of BCA 2022 Amendment 2.	<p>Note:</p> <p><i>Compliance commentary only. No action is required in this regard.</i></p>
D2D21 Plant Rooms & Lift Motor Rooms Concession	<p>A ladder may be used in lieu of a stairway to provide egress from a plant room with a floor area of not more than 100m² or all but one point of egress from a plant room or a lift machine room with a floor area not more than 200m².</p> <p>Sub-clause (2) sets out the parameters for the ladders permitted to be used in this circumstance.</p>	<p>Compliance Readily Achievable:</p> <p>Details to be included into the design.</p>
D2D22 Access to Lifts Pits	Access to lift pits with a depth of under 3m must be provided through the lowest landing doors. If a lift pit exceeds 3m in depth, access must be provided in accordance with sub-clause (b).	<p>Compliance Readily Achievable:</p> <p>Details to be included into the design.</p>
Part D3	Construction of Exits	
D3D2 Application of Part	With the exception of specified clauses in this part the Deemed-to-Satisfy Provisions of this Part do not apply to the internal parts of sole-occupancy units in Class 3 buildings.	<p>Note:</p> <p>Compliance commentary only. No action is required in this regard.</p>
D3D3 Fire Isolated Stairways & Ramps	A stairway or ramp, including landings that are required to be within a fire-resisting shaft must be constructed of non-combustible materials to protect the structural integrity of the shaft.	<p>Compliance Readily Achievable:</p> <p>Details to be included into the design.</p>
D3D5	In a required fire-isolated stairway there must be no direction connection between –	Rising and descending stairs are not provided.

+ Clause	+ Reference	+ Comment
Separation of rising and descending stair flights	<ul style="list-style-type: none"> + A flight rising from a storey below the level of access to open space; and + A flight descending from a storey above that level. <p>Any construction that separates or is common to the rising and descending flights must be non-combustible and smoke proof.</p>	
D3D8 Installations in Exits and Paths of Travel	<p>If installed in a path of travel to an exit, electrical distribution boards, communication cupboards and the like containing motors, etc. are to be enclosed with non-combustible construction (or a fire protective covering), and doors are to be provided with smoke seals to the perimeter.</p>	<p>Compliance Readily Achievable: Details to be included into the design.</p>
D3D9 Enclosure of Space Under Stairs and Ramps	<p>The space below a required fire-isolated stairway or ramp in a fire-isolated shaft must not be enclosed to form a cupboard or other enclosed space.</p> <p>If the required stairway or ramp is non-fire-isolated, (including an external stairway) any cupboard underneath must have an FRL of 60/60/60, with a self-closing -/60/30 door.</p>	<p>Compliance Readily Achievable: Details of the proposed pram storage under the childcare stairway to be provided for review.</p>
D3D10 Width of Required Stairways and Ramps	<p>A required stairway or ramp that exceeds 2m in width is considered as having a width of only 2m unless it is divided by a handrail or barrier and each division has a width not more than 2m.</p>	<p>Note: We note there are no stairways or ramps that exceed 2m in width.</p>
D3D12 Fire-Isolated Passageways	<p>The enclosing construction of a fire-isolated passageway must have an FRL when tested for a fire outside the passageway in another part of the building of-</p> <ul style="list-style-type: none"> + If the passageway discharges from a fire-isolated stairway or ramp – not less than that required for the stairway or ramp shaft; or + In any other case – not less than 60/60/60. <p>Notwithstanding the above, the top construction of a fire-isolated passageway need not have an FRL if the walls of the fire-isolated passageway extend to the underside of-</p> <ul style="list-style-type: none"> + A non-combustible roof covering; or + A ceiling having a resistance to the incipient spread of fire of not less than 60 minutes separating the roof space or ceiling space in all areas surrounding the passageway within the fire compartment. 	<p>Compliance Readily Achievable: Details to be included into the design and reviewed at Detailed Design stage.</p>
D3D13 Roof as Open Space	<p>If an exit discharges to a roof, it must have an FRL of at least 120/120/120 and not have any roof-lights or other openings within 3m of the</p>	<p>Compliance Readily Achievable: Details to be included into the design and reviewed at Detailed</p>

+ Clause	+ Reference	+ Comment												
	<p>path of travel of persons using the exit to reach a road or open space.</p>	<p>Design stage. It is necessary to check and review there is no penetrations in the ground floor slab externally which can be exposed to the egress paths of travel.</p>												
<p>D3D14 Goings and Risers</p>	<p>The stairs must comply with the tread, riser and going dimensions of this clause and the nosing of the stairs must be provided with a non-slip tread and meet the provisions of AS1428.1-2009.</p> <p>The following will apply in relation to the construction of all stairways:</p> <ul style="list-style-type: none"> + Stairway must have not more than 18 and not less than 2 risers in each flight. + Goings and risers within the stair flights must be constant throughout. + Risers must be solid construction with no gaps and treads must have non slip finishes and stair nosings. + Goings and risers are to be in accordance with BCA Table D3D14 <p>In a Class 9b building used as an entertainment venue, the must be provided:</p> <ul style="list-style-type: none"> + not more than one helical stairway serving as a required exit and that stairway must— <ul style="list-style-type: none"> – have a width of not less than 1500mm; and – be of constant radius; and – be constructed so that each tread, when measured 500mm in from its narrow end, has a width of at least 280mm; and + In a curved stairway serving as a required exit — an internal radius of not less than twice the width of the stair. + Conspicuous edges must be provided to the treads of steps. <table border="1" data-bbox="448 1675 975 1832"> <thead> <tr> <th data-bbox="448 1675 767 1742">+ Application</th> <th colspan="2" data-bbox="767 1675 975 1742">+ Surface Conditions</th> </tr> <tr> <td data-bbox="448 1742 767 1771"></td> <th data-bbox="767 1742 871 1771">+ Dry</th> <th data-bbox="871 1742 975 1771">+ Wet</th> </tr> </thead> <tbody> <tr> <td data-bbox="448 1771 767 1800">Tread or landing surface</td> <td data-bbox="767 1771 871 1800">P3/R10</td> <td data-bbox="871 1771 975 1800">P4/R11</td> </tr> <tr> <td data-bbox="448 1800 767 1832">Nosing or landing strip</td> <td data-bbox="767 1800 871 1832">P3</td> <td data-bbox="871 1800 975 1832">P4</td> </tr> </tbody> </table>	+ Application	+ Surface Conditions			+ Dry	+ Wet	Tread or landing surface	P3/R10	P4/R11	Nosing or landing strip	P3	P4	<p>Compliance Readily Achievable:</p> <p>Details to be included into the design and reviewed at Detailed Design stage.</p>
+ Application	+ Surface Conditions													
	+ Dry	+ Wet												
Tread or landing surface	P3/R10	P4/R11												
Nosing or landing strip	P3	P4												
<p>D3D15 Landings</p>	<p>In a stairway –</p> <ul style="list-style-type: none"> + Landings must be a minimum of 750mm long, and where it involves a change of direction the length is measured 500mm from the inside edge of the landing. 	<p>Compliance Readily Achievable:</p> <p>Details to be included into the design and reviewed at Detailed Design stage.</p>												

+ Clause	+ Reference	+ Comment																		
	<p>+ Have a slip resistance of the surface of the nosing strip in accordance with Table D3D15 and tested in accordance with AS 4586.</p> <table border="1" data-bbox="446 387 973 638"> <thead> <tr> <th data-bbox="446 387 766 477">+ Application</th> <th colspan="2" data-bbox="766 387 973 477">+ Surface Conditions</th> </tr> <tr> <td data-bbox="446 477 766 510"></td> <th data-bbox="766 477 869 510">+ Dry</th> <th data-bbox="869 477 973 510">+ Wet</th> </tr> </thead> <tbody> <tr> <td data-bbox="446 510 766 544">Ramps steeper than 1:14</td> <td data-bbox="766 510 869 544">P4/R11</td> <td data-bbox="869 510 973 544">P5/R12</td> </tr> <tr> <td data-bbox="446 544 766 589">Ramp steeper than 1:20 but not steeper than 1:14</td> <td data-bbox="766 544 869 589">P3/R10</td> <td data-bbox="869 544 973 589">P4/R11</td> </tr> <tr> <td data-bbox="446 589 766 622">Tread or landing surface</td> <td data-bbox="766 589 869 622">P3/R10</td> <td data-bbox="869 589 973 622">P4/R11</td> </tr> <tr> <td data-bbox="446 622 766 645">Nosing or landing strip</td> <td data-bbox="766 622 869 645">P3</td> <td data-bbox="869 622 973 645">P4</td> </tr> </tbody> </table>	+ Application	+ Surface Conditions			+ Dry	+ Wet	Ramps steeper than 1:14	P4/R11	P5/R12	Ramp steeper than 1:20 but not steeper than 1:14	P3/R10	P4/R11	Tread or landing surface	P3/R10	P4/R11	Nosing or landing strip	P3	P4	
+ Application	+ Surface Conditions																			
	+ Dry	+ Wet																		
Ramps steeper than 1:14	P4/R11	P5/R12																		
Ramp steeper than 1:20 but not steeper than 1:14	P3/R10	P4/R11																		
Tread or landing surface	P3/R10	P4/R11																		
Nosing or landing strip	P3	P4																		
<p>D3D16 Thresholds</p>	<p>The threshold of a doorway must not incorporate a step or ramp at any point closer to the doorway than the width of the door leaf unless –</p> <ul style="list-style-type: none"> – the doorway opens to a road or open space, external stair landing or external balcony; and – the door sill is not more than 190mm above the finished surface of the ground, balcony, or the like, to which the doorway opens. 	<p>Compliance Readily Achievable: Details to be developed at detailed design stage.</p>																		
<p>D3D17 Barriers to Prevent Falls</p>	<p>A continuous barrier must be provided along the side of—</p> <ul style="list-style-type: none"> + a roof to which general access is provided; and + a stairway or ramp; and + a floor, corridor, hallway, balcony, deck, verandah, mezzanine, access bridge or the like; and + any delineated path of access to a building, <p>if the trafficable surface is 1m or more above the surface beneath.</p> <p>The above requirements of do not apply to—</p> <ul style="list-style-type: none"> + the perimeter of a stage, rigging loft, loading dock or the like; or + areas referred to in D3D23; or + a retaining wall unless the retaining wall forms part of, or is directly associated with a delineated path of access to a building from the road, or a delineated path of access between buildings; or + a barrier provided to an openable window covered by D3D29. <p>A barrier required by this clause must be constructed in accordance with D3D18, D3D19, D3D20 and, if a wire barrier is used, D3D21.</p>	<p>Compliance Readily Achievable: Details to be included into the design and reviewed at Detailed Design stage.</p>																		

+ Clause	+ Reference	+ Comment
<p>D3D18 Height of Barriers</p>	<p>The height of a barrier required by D3D17 must be not less than the following:</p> <ul style="list-style-type: none"> + For stairways or ramps with a gradient of 1:20 or steeper — 865mm. + For landings to a stair or ramp where the barrier is provided along the inside edge of the landing and does not exceed 500mm in length — 865mm. + In front of fixed seating on a mezzanine or balcony within an auditorium in a Class 9b building, <ul style="list-style-type: none"> – 1m; or – 700mm where the horizontal projection extends not less than 1m outwards from the top of the barrier; or + For all other locations — 1m. <p>For a barrier provided from D3D17 —</p> <ul style="list-style-type: none"> + barrier heights are measured vertically from the surface beneath, except that for stairways the height must be measured above the nosing line of the stair treads; and + a transition zone may be incorporated where the barrier height changes from 865mm on a stair flight or ramp to 1m at a landing or floor. 	<p>Compliance Readily Achievable: Details to be included into the design and reviewed at Detailed Design stage.</p>
<p>D3D19 Openings in Barriers</p>	<p>Openings in a required balustrade must not allow a 125mm sphere to pass through unless in a fire-isolated stairway, fire-isolated ramp or other area used primarily for emergency purposes. This is to the exception of fire-isolated stairs and ramps serving a Class 9b early childhood centre, or generally external stairways, which must still comply with the 125mm gap requirement.</p> <p>In a fire-isolated stairway, fire-isolated ramps or other areas used primarily for emergency purposes openings in a required balustrade –</p> <ul style="list-style-type: none"> + must not allow a 300mm sphere to pass through; or + where rails are used – <ul style="list-style-type: none"> – a 150mm sphere must not be able to pass through the opening between the nosing line of the stair treads and the rail or between the rail and the floor of the landing, balcony, or the like; and – the opening between rails must not be more than 460mm. 	<p>Compliance Readily Achievable: Details to be included into the design and reviewed at Detailed Design stage.</p>

+ Clause	+ Reference	+ Comment
	<p>In a class 7 (other than carparks) and Class 8 buildings, opening in a required balustrade –</p> <ul style="list-style-type: none"> + must not allow a 300mm sphere to pass through; or + where rails are used - <ul style="list-style-type: none"> – a 150mm sphere must not be able to pass through the opening between the nosing line of the stair treads and the rail or between the rail and the floor of the landing, balcony or the like; and – the opening between the rails must not be more than 460mm. <p>The maximum 125mm balustrade opening for a stairway, such as a non-fire isolated stairway, is measured above the nosing line of the stair treads.</p> <p>Where a required balustrade is fixed to the vertical face forming an edge of a landing, balcony, deck, stairway or the like, the opening formed between the balustrade and the face must not exceed 40 mm. The opening is measured horizontally from the edge of the surface to the nearest internal face of the balustrade</p>	
<p>D3D20 Barrier Climbability</p>	<p>A barrier required by D3D17, located on a floor more than 1m above the surface beneath, must not incorporate horizontal or near horizontal elements that could facilitate climbing between 150mm and 760mm above the floor.</p> <p>This does not apply to –</p> <ul style="list-style-type: none"> + Fire isolated stairways, fire-isolated ramps and other areas used primarily for emergency purposes, <u>other than</u> – <ul style="list-style-type: none"> – external stairways; and – external ramps; and + Class 7 (other than carparks) and Class 8 buildings 	<p>Compliance Readily Achievable: Details to be included into the design and reviewed at Detailed Design stage.</p> <p>Note: Climbability of wire mesh to be reviewed in the childcare centre.</p>
<p>D3D22 Handrails</p>	<p>Handrails must be located along at least one side of a ramp or flight unless the width is 2m or more requiring handrails on both sides.</p> <p>In a Class 9b primary school or a building that contains an early childhood centre;</p> <ul style="list-style-type: none"> + have one handrail fixed at a minimum height of 865mm and a second handrail fixed between 665mm and 750mm, and + with a cross sectional dimension not less than 16mm and not greater than 45mm 	<p>Compliance Readily Achievable: Details to be included into the design and reviewed at Detailed Design stage.</p>

+ Clause	+ Reference	+ Comment
	<p>as measured in any direction across its centre, fixed at a height between 450mm and 700mm in a class 9b early childhood centre.</p> <p>In other cases, handrails must be fixed at a minimum height of 865mm and be continuous between stair flight landings and have no on or above them that may break the hand hold. If in a required exit serving an accessible area, must comply with AS 1428.1.</p> <p>Handrails in a Class 3 must –</p> <ul style="list-style-type: none"> + Be located along at least one side; and + Be located along the full length, except where it is associated with a barrier; and + Have the top surface of the handrail a minimum of 865mm above the stairs or floor; and + Have no obstruction on or above that may break a handhold, except for newel posts, stanchions or the like. <p>These requirements do not apply to handrails referred to in D3D23, a stairway or ramp providing a change in elevation of less than 1m, a land <u>or</u> a winder where a newel post is installed to provide a handhold.</p>	
<p>D3D23 Fixed Platforms, Walkways Stairways and Ladders</p>	<p>A fixed platform, walkway, stairway, ladder, any going and riser, any balustrade or other barrier attached thereto may comply with AS1657 if it only serves a machinery or plant room.</p>	<p>Compliance Readily Achievable: Details to be included into the design and reviewed at Detailed Design stage.</p>
<p>D3D24 Doorways and Doors</p>	<p>A doorway forming part of a required exit – or a doorway in a patient care area of a Class 9a health-care building must not be fitted with a revolving door and must not be fitted with a roller shutter or tilt-up door unless it serves a part with a floor area not more than 200m² and the doorway is the only required exit from the building or part; and it is held in the open position while the building or part is lawfully occupied.</p> <p>Must not be fitted with a sliding door unless it leads directly to a road or open space; and the door is able to be opened manually under a force of not more than 110N. Except for a door in a patient care area of a Class 9a health-care building, if fitted with a door which is power-operated it must be able to be opened manually under a force of not more than 110N if there is a malfunction or failure of the power source; and if it leads</p>	<p>Compliance Readily Achievable: Details to be developed at detailed design stage.</p> <p>Note: No roller shutters in egress paths are noted in the design.</p>

+ Clause	+ Reference	+ Comment
	<p>directly to a road or open space it must open automatically if there is a power failure to the door or on the activation of a fire or smoke alarm anywhere in the fire compartment served by the door.</p> <p>A power-operated door in a path of travel to a required exit must be able to be opened manually under a maximum force of 110N if there is a malfunction.</p>	
<p>D3D25 Swinging Doors</p>	<p>A swinging door forming part of a required exit must not encroach the required width of a required exit by way of the swing of the door, or the door itself including associated hardware whilst in the open position.</p> <p>A swinging door must not swing against the direction of egress unless</p> <ul style="list-style-type: none"> + it serves a building or part with a floor area not more than 200m², it is the only <i>required exit</i> from the building or part and it is fitted with a device for holding it in the open position; or + it serves a sanitary compartment or airlock (in which case it may swing in either direction); 	<p>Further Information Required:</p> <p>If the retail tenancies on the north are combined to form a single retail tenancy of >200m² the exit doors must swing out in the direction of egress.</p> <p>Compliance Readily Achievable:</p> <p>All exit doorways (doors into fire stairways, to open space or horizontal exits) must open in the direction of egress.</p> <p>Note: If the retail tenancies on the north are combined to form a single retail tenancy of >200m² the exit doors must swing out in the direction of egress.</p> <p>Note: The single exits to retail tenancies which swing against egress must have hold-open device. This is permissible on the basis of each tenancy being a part of the floor which is <200m².</p>
<p>D3D26 Operation of Latch</p>	<p>A door in a path of travel to an exit must be readily openable via the provision of single downward lever action hardware located between 900-1100mm AFFL in an area required to be accessible, otherwise single pushing action hardware between 900-1200mm AFFL is permitted.</p> <p>These requirements do not apply to a door serving:</p> <ul style="list-style-type: none"> + a vault, strong-room, sanitary compartment, or the like, + a sole-occupancy unit in a Class 2 building or a Class 4 part of a building; or + a sole-occupancy unit in a Class 3 building (other than an entry door to a sole-occupancy unit of a boarding house, guest house, hostel, lodging house or backpacker accommodation); or 	<p>Compliance Readily Achievable:</p> <p>Details to be developed at detailed design stage.</p>

+ Clause	+ Reference	+ Comment
	<ul style="list-style-type: none"> + a sole-occupancy unit with a floor area not more than 200m² in a Class 5, 6, 7 or 8 building; or + a space which is otherwise inaccessible to persons at all times when the door is locked; 	
<p>D3D27 Re-entry From Fire-Isolated Exits</p>	<p>Doors of a fire-isolated exit must not be locked from the inside in a fire-isolated exit serving a storey above 25m effective height, throughout the exit.</p> <p>This clause details the exceptions to the above requirements if the doors are fitted with an automatic failsafe device that automatically unlocks the door upon the activation of a fire alarm as follows:</p> <ul style="list-style-type: none"> + On at least every fourth storey, the doors are not able to be locked and a sign is fixed on such doors stating that re-entry is available; or + An intercommunication system, or an audible or visual alarm system, operated from within the enclosure is provided near the doors and a sign is fixed adjacent to such doors explaining its purpose and method of operation. <p>In a class 9b early childhood centre the requirements detailed above do not apply if the door is fitted with a fail-safe device that automatically unlocks the door upon activation of a fire alarm.</p>	<p>Further Information Required / Performance Solution</p> <p>Confirm method of re-entry for fire-isolated stairs. Typically dealt with as a performance solution to rationalise extent of intercoms.</p>
<p>D3D28 Signs on Doors</p>	<p>It is a requirement that signs to alert persons that the operation of smoke doors, fire doors, and doors discharging from fire isolated exits, must not be impaired must be installed where they can be readily seen.</p>	<p>Compliance Readily Achievable:</p> <p>Details to be developed at detailed design stage.</p>

- + A sign, to alert persons that the operation of certain doors must not be impaired, must be installed where it can readily be seen on, or adjacent to, a—
 - A required fire door providing direct access to a fire-isolated exit; and
 - A required smoke door, on the side of the door that faces a person seeking egress and, if the door is fitted with a device for holding it in the open position, on either the wall adjacent to the doorway or both sides of the door; and
 - Fire door forming part of a horizontal exit; and
 - Smoke door that swings in both directions; and
 - Door leading from a fire isolated *exit* to a road or *open space*, on each side of the door.
- + A sign referred to in (a) must be in capital letters not less than 20 mm high in a colour contrasting with the background and state—

Any new self-closing fire and/or smoke doors leading into the fire stair or forming part of a Horizontal Exit or smoke compartment are to be provided with signage as follows:

+ Clause	+ Reference	+ Comment
----------	-------------	-----------

FIRE SAFETY DOOR
DO NOT OBSTRUCT
DO NOT KEEP OPEN

Any new automatic closing fire and/or smoke doors which are held on hold open devices that leads into the fire stair or forming part of a Horizontal Exit or smoke compartment are to be provided with signage as follows:

FIRE SAFETY DOOR
DO NOT OBSTRUCT

In addition to the above, the doors which provide access to the fire isolated exits and also the Horizontal Exits must have signage provided adjacent to the entry doorway which states the following (ref Clause 109 of EP&A (DCFS) Regulation 2021):

**OFFENCES
RELATING TO
FIRE EXITS**

By virtue of the regulations under the Environmental Planning And Assessment Act 1979, it is an offence:

(a) to place anything in this exit that may impede the free passage of persons, or

(b) to interfere with or cause obstruction or impediment to, the operation of the doors providing access to this exit, or

(c) to remove, damage or otherwise interfere with this notice.

D3D29 Protection of Openable Windows	In a Class 3 / 9b early childhood centre, a window must be provided with protection if the floor below the window is 2m or more above the surface beneath. Where the lowest level of the window opening is less than 1.7m above the floor, a window opening must be protected.	Compliance Readily Achievable: Details to be developed at detailed design stage.
--	--	--

Part D4 Access for People with Disabilities

D4D2 General Building Access Requirements	<p>The extent of access required depends on the classification of the building. Buildings and parts of buildings must be accessible as set out in this clause.</p> <p><u>Residential parts.</u> Access is required to all common areas and to the doorway of each sole-occupancy unit.</p> <p><u>Class 6 parts.</u> To and within all areas normally used by occupants.</p> <p><u>Commercial parts.</u> Access is required to and within all areas normally used by the occupants, including the ancillary class 7a part.</p> <p>A building, or part thereof, must comply with the requirements of BCA Part 4 if accessibility is deemed to be applicable under D4D2, unless otherwise exempted under Clause D4D5.</p>	Refer to our access assessment in Section 4.0 of this report.
---	--	---

Section E Services and Equipment

Part E1 Fire Fighting Equipment

+ Clause	+ Reference	+ Comment
<p>E1D2 Fire Hydrants</p>	<p>A Hydrant system is required to be installed in accordance with AS 2419.1 – 2021 given the total floor area of the building exceeding 500m².</p> <p><u>Note:</u> The below comprises a limited summary of requirements under AS 2419.1 – 2021. Refer to the full standard for all applicable requirements.</p> <p>+ Fire Brigade Booster Assemblies:</p> <p>A fire brigade booster assembly shall be located (including but not limited to) -</p> <ul style="list-style-type: none"> + within or affixed to the facade of the building containing the principal pedestrian entrance and not more than 20 m from the principal pedestrian entrance; + within or affixed to the facade of the building containing the principal pedestrian entrance and identified by a visual alarm device (VAD) in accordance with Clause 7.3.2; or + remote from the building and within sight of the principal pedestrian entrance to the building - <ul style="list-style-type: none"> - adjacent to the site boundary and the principal vehicle access for the fire brigade pumping appliance to the building or site; or - not more than 20m from the facade of the building containing the principal pedestrian entrance and not more than 20m from the main pedestrian entrance. <p>In addition, a fire brigade booster assembly shall be (including but not limited to):</p> <ul style="list-style-type: none"> + Not more than 10m from a hardstand + Not less than 10m from: <ul style="list-style-type: none"> - Any high voltage electrical distribution equipment such as transformers and distribution boards; - Any electric vehicle charging station regardless of voltage; - Any stored quantity of dangerous goods; - Any external combustible storage. + Not less than 3m from the vent terminal of any gas assembly or gas measurement systems. + Not less than 3m from the discharge outlet of any building exhaust system when operating in fire mode. 	<p>Performance Solution:</p> <p>The hydrant booster is not within sight of the main entry.</p> <p>Fire services designer to verify any fire hydrant non-compliances, such as booster location and hydrant locations.</p> <p>Compliance Readily Achievable:</p> <p>Details to be developed at detailed design stage. Fire Hydrant coverage markups to be provided demonstrating compliance.</p>

+ Clause	+ Reference	+ Comment
	<p>Where located less than 10m from a non-sprinkler protected building, the booster shall be protected in accordance with the requirements of Cl. 7.6.2 of AS 2419.1 -2021.</p> <p>+ Internal Hydrants</p> <p>Any Internal Hydrants are to be located within the fire isolated exits or within 4m of the top riser of the non-fire isolated exits (external stairs in lieu of fire stairs). In addition, if floor coverage cannot be achieved a Performance Solution is required to locate hydrants >4m from an exit in Class 5-9 buildings.</p> <p>+ External Hydrants</p> <p>External hydrants are required to be located:</p> <ul style="list-style-type: none"> + Not less than 10m from: <ul style="list-style-type: none"> - Any high voltage electrical distribution equipment such as transformers and distribution boards - Any electric vehicle charging station regardless of voltage; - Any stored quantity of dangerous goods; - Any external combustible storage. + Not less than 3m from the vent terminal of any gas assembly or gas measurement systems + Not less than 3m from the discharge outlet of any building exhaust system when operating in fire mode. <p>+ Hydrant Pump Rooms</p> <p>Where required, a hydrant pump room is required to have a door opening to a road or open space, or a door opening direct into a fire isolated airlock connected to a fire stair. Pump rooms shall be weatherproof and only contain firefighting pump sets and associated equipment. A minimum of 1m clearance must be provided around all sides of each pump set. For additional requirements refer to Cl. 6.11 of AS 2419.1 – 2017.</p> <p>+ Applicability of AS 2419.1 – 2021</p> <p>A Performance Solution is required for a hydrant system serving:</p> <ul style="list-style-type: none"> + Buildings and associated areas that include special hazards. 	

+ Clause	+ Reference	+ Comment
<p>E1D3 Fire Hose Reels</p>	<p>Does not apply to Class 3</p> <p>A fire hose reel system must be provided to serve a building where one or more internal fire hydrants are installed or in a building with a floor area greater than 500m².</p> <p>Fire Hose Reels are to be located within 4m of an exit, or located adjacent to an internal hydrant (other than one within a fire isolated exit). Where system coverage is not achieved by the above, additional FHR may be located in paths of travel to an exit. Fire hose reels must be located internally, externally or in any combination to achieve the system coverage specified in AS 2441.</p> <p>Fire hose reels must not pass through any fire or smoke doors except if it is a doorway referred to in BCA Clause C3D6 (1)(e), C3D6(5)(d), C3D13, C3D14 or C4D14.</p> <p>Fire hose reels must only serve the storey on which they are located except for an SOU or not more than 2 storeys for a Class 6 / 9 building may be served by a single fire hose reel located at the level of egress.</p>	<p>Performance Solution: Fire services designer to verify any fire hose reel non-compliances.</p> <p>Compliance Readily Achievable: Details to be developed at detailed design stage. Fire Hose Reels coverage markups to be provided demonstrating compliance.</p>
<p>E1D4 Sprinklers</p>	<p>A sprinkler system must be installed in a building or part of a building where required by Clause E1D5 – E1D12 as applicable, and comply with Spec 17 and 18 as applicable.</p>	<p>Performance Solution: Fire services designer to verify any sprinkler non-compliances.</p> <p>Compliance Readily Achievable: Design statement to be provided at Construction Certificate stage.</p>
<p>E1D5 Where sprinklers are required: all classifications</p>	<p>Sprinklers are required throughout all buildings if any part of the building has an effective height of more than 25m –</p> <ul style="list-style-type: none"> + including an open-deck carpark within a multi-classified building; but + excluding <ul style="list-style-type: none"> - an open-deck carpark being a separate building; and - a class 8 electricity network substation, with a floor area not more than 200m², located within a multi-classified building. 	<p>Compliance Readily Achievable: Design statement to be provided at Construction Certificate stage.</p>
<p>E1D14 Portable Fire Extinguishers</p>	<p>Portable fire extinguishers must be provided as listed in Table E1D14 and must be selected, located and distributed in accordance with Sections 1, 2, 3 and 4 of AS 2444.</p> <p>In a Class 3 building, portable fire extinguishers must be located within 10m of each SOU doorway.</p>	<p>Compliance Readily Achievable Design statement to be provided at Construction Certificate stage.</p>

+ Clause	+ Reference	+ Comment
E1D15 Fire Control Centres	<p>A Fire Control Centre facility in accordance with Spec 19 must be provided for building with a total floor area of >18,000m² or over 25m Effective Height.</p> <p>The fire control centre must provide an area from which fire-fighting operations or other emergency procedures can be directed or controlled.</p>	<p>Performance Solution:</p> <p>The fire control room does have direct access to the entrance of the building. The front entrance of the building is considered to be the residential and commercial lobbies.</p>
E1D16 Fire Precautions During Construction	<p>In buildings under construction at least one fire extinguisher to suit Class A, B and C fires and electrical fires must be provided at all times on each storey adjacent to a required exit and if the building has reached an effective height of 12m the required hydrant and hose reel systems must be installed in at least every storey that's covered by the roof or floor structure above (except the 2 uppermost storeys) and any required booster connections must be installed.</p>	<p>Note:</p> <p>Contractor to Note</p>
E1D17 Provisions for Special Hazards	<p>Suitable additional provisions must be made for fire-fighting if unique problems could arise due to;</p> <ul style="list-style-type: none"> + The nature or quantity of materials stored, displayed or used in a building on the allotment; or + The location of the building in relation to a water supply for firefighting purposes. 	<p>Further Information Required:</p> <p>Services consultants to provide confirmation of any special hazards such as generators or battery storage.</p>

Part E1 Specifications

Spec. 17 Fire Sprinkler Systems	<p>+ Application of Sprinkler Standards</p> <p>Subject to the requirements of this specification, an automatic fire sprinkler system must comply with the applicable standard as listed in S17C2.</p> <p>+ Separation of Sprinkler Protected and Non Sprinkler Protected Areas</p> <p>Where a part of a building is not protected with sprinklers, the sprinklered and non-sprinklered parts must be fire-separated with a wall or floor which must—</p> <ul style="list-style-type: none"> + comply with any specific requirement of the Deemed-to-Satisfy Provisions of the BCA; or + where there is no specific requirement, comply with the relevant part of AS 2118, FPAA101D or FPAA101H. + Any openings must be protected in accordance with the requirements of Part C4 of the BCA. <p>+ Quick Response Sprinklers</p>	<p>Compliance Readily Achievable:</p> <p>Design statement to be provided at Construction Certificate stage.</p> <p>Note: the childcare centre within the building is required to be provide with quick response sprinklers.</p>
---	--	--

+ Clause	+ Reference	+ Comment
	<p>Quick response sprinklers may be installed only if they are suitable for the type of application proposed and it is demonstrated that the sprinkler system is designed to accommodate their use.</p> <p>+ Sprinkler Valve Enclosures</p> <p>Sprinkler alarm valves must be located in a secure room or enclosure which has direct egress to a road or open space.</p> <p>All sprinkler valve rooms and enclosures must be secured with a system suitable for use by the fire brigade.</p> <p>+ Water Supply</p> <p>A required sprinkler system must be provided with at least one water supply.</p> <p>A required sprinkler system in a building greater than 25m in effective height must be provided with dual water supply except that a secondary water supply storage capacity of 25,000 litres may be used if—</p> <ul style="list-style-type: none"> + the storage tank is located at the topmost storey of the building; and + the building occupancy is classified as no more hazardous than Ordinary Hazard 2 (OH2) under AS 2118.1; and + an operational fire brigade service is available to attend a building fire. <p>+ Building Occupant Warning System</p> <p>A required sprinkler system, except a FPAA101D sprinkler system, must be connected to and activate a building occupant warning system complying with S20C7.</p> <p>+ Connection to Other Systems</p> <p>Where a smoke hazard management system is installed and is actuated by smoke detectors, the sprinkler system must, wherever practicable, be arranged to also activate the smoke hazard management system.</p> <p>+ Anti Tamper Devices</p> <p>Where a sprinkler system is installed—</p> <ul style="list-style-type: none"> + over any stage area in a theatre, public hall or the like, visual and audible status indication of sprinkler valves must be provided at the location normally used by the stage manager; or + in a space housing lift electrical and control equipment (including machine rooms, secondary floors and sheave 	

+ Clause	+ Reference	+ Comment
	<p>rooms), any valves provided to control sprinklers in these spaces must be located adjacent to the space.</p> <ul style="list-style-type: none"> + Any valves provided to control sprinklers must be fitted with anti-tamper monitoring devices connected to a monitoring panel. <p>+ Sprinklers in Car Parks</p> <p>A sprinkler system protecting a carpark complying with S5C19(3) in a multi-classified building must—</p> <ul style="list-style-type: none"> + be independent of the sprinkler system protecting any part of the building not used as a carpark; or + if forming part of a sprinkler system protecting a part of the building not used as a carpark, be designed such that the section protecting the non-carpark part can be isolated without interrupting the water supply or otherwise affecting the effective operation of the section protecting the carpark. <p>+ Residential Care Buildings</p> <p>In addition to the provisions of AS 2118.4, a sprinkler system in—</p> <ul style="list-style-type: none"> + a Class 3 building used as a residential care building; or + a Class 9a health-care building used as a residential care building; or + a Class 9c building, <p>must comply with the below.</p> <p>Any sprinkler system referred to above must—</p> <ul style="list-style-type: none"> + be provided with a monitored main stop valve in accordance with AS 2118.1; and + be permanently connected with a direct data link or other approved monitoring system to a fire station or fire station dispatch centre. <p>+ Sprinkler Systems in Lifts</p> <p>Where sprinklers are installed in a space housing lift electrical and control equipment, including machine rooms, secondary floors and sheave rooms, sprinklers in these spaces must—</p> <ul style="list-style-type: none"> + have heads protected from accidental damage by way of a guard that will not impair the performance of the head; and + be capable of being isolated and drained, either separately or collectively, without 	

+ Clause	+ Reference	+ Comment
	<p>isolating any other sprinklers within the building.</p> <p>Valves provided to control sprinklers referred to in (1) must be installed in accordance with S17C10(2).</p> <p style="text-align: center;">+ Early Childhood Centres</p> <p>Quick response sprinklers must be provided to a Class 9b early childhood centre required to have an automatic fire sprinkler system.</p> <p><i>Note: The above does not apply to a Class 9b early childhood centre—</i></p> <ul style="list-style-type: none"> + wholly within a storey that provides direct egress to a road or open space; or + with a rise in storeys of not more than 2, where the Class 9b early childhood centre is the only use in that building. 	
<p>Spec. 19 Fire Control Centres</p>	<p>This Specification describes the construction and content of required fire control centres and rooms.</p> <p>A fire control room is a fire control centre in a dedicated room with additional specific requirements.</p>	<p>Compliance Readily Achievable: Details to be provided at detailed design stage.</p>
<p>S19C3 Purpose and Content of Fire Control Centre</p>	<p>A fire control centre must—</p> <ul style="list-style-type: none"> + provide an area from which fire-fighting operations or other emergency procedures can be directed or controlled; and + contain controls, panels, telephones, furniture, equipment and the like associated with the required fire services in the building; and + not be used for any purpose other than the control of— <ul style="list-style-type: none"> - fire-fighting activities; and - other measures concerning the occupant safety or security. 	<p>Compliance Readily Achievable: Details to be developed at detailed design stage.</p>
<p>S19C4 Location of a Fire Control Centre</p>	<p>A fire control centre must be so located in a building that egress from any part of its floor, to a road or open space, does not involve changes in level which in aggregate exceed 300mm.</p>	<p>Compliance Readily Achievable: Details to be developed at detailed design stage.</p>
<p>S19C5 Equipment not Permitted within a Fire Control Centre</p>	<p>An internal combustion engine, pumps, sprinkler control valves, pipes and pipe fittings must not be located in a fire control centre, but may be located in rooms accessed through the fire control centre.</p>	<p>Compliance Readily Achievable: Details to be developed at detailed design stage.</p>

+ Clause	+ Reference	+ Comment
<p>S19C6 Ambient Sound Level for a Fire Control Centre</p>	<p>The ambient sound level within the fire control centre measured when all fire safety equipment is operating in the manner in which it operates in an emergency must not exceed 65 dB(A). Noting:</p> <ul style="list-style-type: none"> + The measurement must be taken for a sufficient time to characterise the effects of all sound sources. + Where there is not a great variation in noise level, a measurement time of 60 seconds may be used. 	<p>Compliance Readily Achievable: Details to be developed at detailed design stage.</p>
<p>S19C7 Construction of a Fire Control Room</p>	<p>A fire control centre in a building more than 50m in effective height must be in a separate room where—</p> <ul style="list-style-type: none"> + the enclosing construction is of concrete, masonry or the like, sufficiently impact resistant to withstand the impact of any likely falling debris, and with an FRL of not less than 120/120/120; and + any material used as a finish, surface, lining or the like within the room complies with the requirements of Spec 7; and + services, pipes, ducts and the like that are not directly required for the proper functioning of the fire control room do not pass through it; and + openings in the walls, floors or ceiling which separate the room from the interior of the building are confined to doorways, ventilation and other openings for services necessary for the proper functioning of the facility. 	<p>Compliance Readily Achievable: Details to be developed at detailed design stage.</p>
<p>S19C8 Protection of Openings in a Fire Control Room</p>	<p>Openings permitted by S19C7 must be protected as follows:</p> <ul style="list-style-type: none"> + Openings for windows, doorways, ventilation, service pipes, conduits and the like, in an external wall of the building that faces a road or open space, must be protected in accordance with the Deemed-to-Satisfy Provisions of Part C4. + Openings in the floors, ceilings and internal walls enclosing a fire control room must, except for doorways, be protected in accordance with the Deemed-to-Satisfy Provisions of Part C4. + A door opening in the internal walls enclosing a fire-control room, must be fitted with a self-closing –/120/30 smoke sealed fire door. + Openings associated with natural or mechanical ventilation must— 	<p>Compliance Readily Achievable: Details to be developed at detailed design stage.</p>

+ Clause	+ Reference	+ Comment
	<ul style="list-style-type: none"> - not be made in any ceiling or floor immediately above or below the fire control room; and - be protected by a –/120/– fire damper if the opening is for a duct through a wall required to have an FRL, other than an external wall. 	
<p>S19C9 Doors to a Fire Control Room</p>	<p>Required doors to a fire control room must open into the room, be lockable and located so that persons using escape routes from the building will not obstruct or hinder access to the room.</p>	<p>Compliance Readily Achievable: Details to be developed at detailed design stage.</p>
<p>S19C10 Size and Contents of a Fire Control Room</p>	<p>The fire control room must be accessible via two paths of travel:</p> <ul style="list-style-type: none"> + one from the front entrance of the building; and + one direct from a public place or fire-isolated passageway which leads to a public place and has a door with an FRL of not less than –/120/30. 	<p>Performance Solution: The fire control room does have direct access to the entrance of the building. The front entrance of the building is considered to be the residential and commercial lobbies.</p>
<p>S19C11 Ventilation and Power Supplier for a Fire Control Room</p>	<p>A fire control room must be ventilated by—</p> <ul style="list-style-type: none"> + natural ventilation from a window or doorway in an external wall of the building which opens directly into the fire control room from a road or open space; or + a pressurisation system that only serves the fire control room, and is installed in accordance with AS 1668.1 as though the room is a fire-isolated stairway; and – is activated automatically by operation of the fire alarm, or sprinkler system complying with Spec. 17, installed in the building and manually by an over-riding control in the room; and – provides a flow of fresh air through the room of not less than 30 air changes per hour when the system is operating and any door to the room is open; and – has fans, motors and ductwork that form part of the system but not contained within the fire control room – protected by enclosing construction with an FRL of not less than 120/120/120; and – has any electrical supply to the fire control room or equipment necessary for its operation connected to the supply side of the main disconnection switch for the building. <p>No openable devices other than necessary doorways, pressure controlled relief louvres</p>	<p>Compliance Readily Achievable: Details to be developed at detailed design stage.</p>

+ Clause	+ Reference	+ Comment
	and windows that are openable by a key, must be constructed in the fire control room.	
S19C12 Sign for a Fire Control Room	The external face of the door to the fire control room must have a sign with the words— <p style="text-align: center;">FIRE CONTROL ROOM</p> in letters not less than 50mm high and of a colour which contrasts with that of the background.	Compliance Readily Achievable: Details to be developed at detailed design stage.
S19C13 Lighting for a Fire Control Room	Emergency lighting in accordance with the Deemed-to-Satisfy Provisions of Part E4. must be provided in a fire control room, except that an illumination level of not less than 400 lux must be maintained at the surface of the plan table.	Compliance Readily Achievable: Details to be developed at detailed design stage.
Part E2	Smoke Hazard Management	
E2D3 General Requirements	<ul style="list-style-type: none"> + An air-handling system which does not form part of a smoke hazard management system in accordance with E2D4 to E2D20 and which recycles air from one fire compartment to another fire compartment or operates in a manner that may unduly contribute to the spread of smoke from one fire compartment to another fire compartment must be designed and installed— <ul style="list-style-type: none"> – to operate as a smoke control system in accordance with AS 1668.1; or – such that it— <ul style="list-style-type: none"> ▪ incorporates smoke dampers where the air-handling ducts penetrate any elements separating the fire compartments served; and ▪ is arranged such that the air-handling system is shut down and the smoke dampers are activated to close automatically by smoke detectors complying with clause 7.5 of AS 1670.1. + For the purposes of the above, each sole-occupancy unit in a Class 2 or 3 building is treated as a separate fire compartment. + Miscellaneous air-handling systems covered by Sections 5 and 6 of AS 1668.1 serving more than one fire compartment (other than a carpark ventilation system) and not forming part of a smoke hazard management system 	Compliance Readily Achievable: Design statement to be provided at Construction Certificate stage.

+ Clause	+ Reference	+ Comment
	<p>must comply with these Sections of the Standard.</p> <ul style="list-style-type: none"> + A smoke detection system must be installed in accordance with S20C6 to operate AS 1668.1 systems that are provided for zone pressurisation and automatic air pressurisation for fire-isolated exits. 	
<p>E2D4 Fire-isolated exits</p>	<ul style="list-style-type: none"> + A part of a building listed below must be provided with <ul style="list-style-type: none"> – An automatic air pressurisation system for fire-isolated exits in accordance with AS 1668.1 or; – Open access ramps of balconies in accordance with D3D6 + The above requirements apply to— <ul style="list-style-type: none"> – The required fire-isolated stairway, including any associated fire-isolated passageway or fire-isolated ramp serving— <ul style="list-style-type: none"> ▪ Any storey above an effective height of 25m; or – A required fire-isolated passageway or fire-isolated ramp with a length of travel more than 60m to a road or open space. + An automatic air pressurisation system for a fire-isolated exit must serve the entire exit. 	<p>Further Information Required / Performance Solution</p> <p>Mechanical designer to verify if there are any other fire engineered performance solution required for stairway pressurisation.</p>
<p>E2D5 Building more than 25m in effective height: Class 2 and 3 buildings and Class 4 part of a building</p>	<p>An automatic smoke detection and alarm system complying with Spec. 20 must be provided to:</p> <ul style="list-style-type: none"> + Class 2 or 3 buildings that are more than 25m in effective height. 	<p>Compliance Readily Achievable:</p> <p>Design statement to be provided at Construction Certificate stage.</p>
<p>E2D6 Buildings more than 25 m in effective height: Class 5, 6, 7b, 8 or 9b buildings</p>	<ul style="list-style-type: none"> + A Class 6 building or part of a building must be provided with a zone pressurisation system between vertically separated fire compartments in accordance with AS 1668.1, if the building is more than 25 m in effective height. + The requirements of the above do not apply to a building that has a fire compartment containing a Class 6 / 9b part (or a combination of these classes in the same fire compartment) where there is only one fire compartment containing 	<p>Performance Solution:</p> <p>To rationalise the zone smoke control system. Examples include pressure differentials between childcare and residential floors and basement and retail ground floor.</p> <p>Compliance Readily Achievable:</p> <p>Design statement to be provided at Construction Certificate stage.</p>

+ Clause	+ Reference	+ Comment
	<p>these classifications in an otherwise Class 3 building.</p> <ul style="list-style-type: none"> + For the purposes of the above, 'vertically separated fire compartments' are fire compartments above and below each other, and not fire compartments within the same storey. 	
<p>NSW E2D16 (Previously Table E2.2a) (NSW Variation)</p> <p>Class 9b – assembly buildings: nightclubs, discotheques and the like</p>	<p>The following provisions apply to all Class 9b assembly buildings:</p> <ul style="list-style-type: none"> + A building or part of a building used as an assembly building must be provided with automatic shutdown of any air-handling system (other than non-ducted individual room units with a capacity not more than 1000 L/s and miscellaneous exhaust air systems installed in accordance with Sections 5 and 6 of AS 1668.1) which does not form part of the smoke hazard management system, on the activation of— <ul style="list-style-type: none"> - smoke detectors installed complying with S20C6; and - any other installed fire detection and alarm system, including a sprinkler system (other than a FPAA101D or FPAA101H system) complying with Specification 17. 	<p>Performance Solution:</p> <p>To rationalise the air-handling shutdown and zone smoke control system to the class 9b childcare with consideration of the conflicting requirements.</p> <p>Compliance Readily Achievable:</p> <p>Design statement to be provided at Construction Certificate stage.</p> <p>Note: Applicable to class 9b childcare. Mechanical air-handling shutdown required.</p>
<p>NSW E2D19 (Previously Table E2.2a)</p> <p>Assembly buildings: theatres and public halls (not listed in E2D18) including lecture theatres and cinema/auditorium complexes</p>	<p>A building or part of a building used as an assembly building (not being a night club, discotheque or the like; or an exhibition hall, museum or art gallery) where the floor area of a fire compartment is more than 2000m², the fire compartment must be provided with—</p> <ul style="list-style-type: none"> + An automatic smoke exhaust system complying with Specification 21; or + Roof mounted automatic smoke-and-heat vents complying with Specification 22, in a single storey building or the top storey of a multi storey building; or + If the floor area of the fire compartment is not more than 5000m² and the building has a rise in storeys of not more than 2— <ul style="list-style-type: none"> - An automatic smoke detection and alarm system complying with Specification 20; or - A sprinkler system (other than a FPAA101D or FPAA101H system) complying with Specification 17. <p>The following buildings are exempt from the provisions of this clause:</p> <ul style="list-style-type: none"> - Sporting complexes, (including sports halls, gymnasiums, 	<p>Compliance Readily Achievable:</p> <p>Design statement to be provided at Construction Certificate stage.</p> <p>Note: Applicable to class 9b childcare. Automatic smoke detection and alarm system required <u>throughout</u> the entire building (basement, bld1 and bld2).</p>

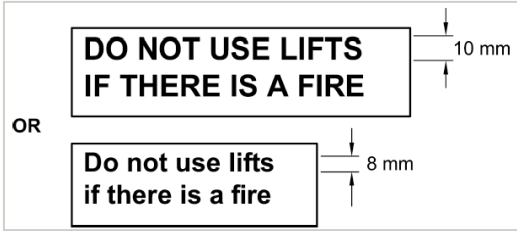
+ Clause	+ Reference	+ Comment
	<p>swimming pools, ice and roller rinks, and the like) other than indoor sports stadiums with total spectator seating for more than 1000 persons.</p> <ul style="list-style-type: none"> - Churches and other places used solely for religious worship. - School classrooms. <p>A building containing a Class 9b early childhood centre must be provided with an automatic smoke detection and alarm system complying with Specification 20 throughout the whole building, including any part of another Class.</p>	
<p>E2D21 Provision for special hazards</p>	<p>Additional smoke hazard management measures may be necessary due to the—</p> <ul style="list-style-type: none"> + Special characteristics of the building; or + Special function or use of the building; or + Special type or quantity of material stored, displayed or used in a building; or + Special mix of classifications within a building or fire compartment, which are not addressed in E2D4 to E2D20. 	<p>Further Information Required: Refer to comments under E1D17 above.</p>
<p>Part E3 Lift Installations</p>		
<p>E3D3 Stretcher Facilities in Lifts</p>	<p>Stretcher facilities, complying with this clause, must be provided in lifts in at least one emergency lift as required by E3D5 or in building where lifts serve any storey above an effective height of 12m.</p> <p>A stretcher facility must accommodate a raised stretcher with a patient lying on it horizontally by providing a clear space not less than 600mm wide x 2000mm long x 1400mm high above the floor level.</p>	<p>Compliance Readily Achievable: Details to be included in the design statement at BCA Construction Certificate Stage.</p>
<p>E3D4 Warning Against Use of Lifts in Fire</p>	<p>Warning signs required be provided must be displayed where they can be readily seen and must comply with the details and dimensions of Figure E3D4 below.</p> 	<p>Compliance Readily Achievable: Detail to be included in the design.</p>
<p>E3D5 Emergency Lifts</p>	<p>An emergency lift (complying with AS 1735.2 or Appendix A of AS 1735.1) must be installed in:</p> <ul style="list-style-type: none"> + A building exceeds 25m in effective height; and 	<p>Compliance Readily Achievable: Design statement to be provided at Construction Certificate stage.</p>

+ Clause	+ Reference	+ Comment
	<p>+ A class 9a building which has patient care areas located on a level that does not have direct egress to a road or open space.</p> <p>The emergency lift must be connected to a standby power supply system where installed; be contained within a fire resisting shaft; and have the following <u>minimum</u> internal dimensions (measured clear of all obstructions including handrails):</p> <ul style="list-style-type: none"> + Depth of car – 2280mm + Width of car – 1600mm + Floor to ceiling height – 2300mm + Door height – 2100mm + Door width – 1300mm 	
E3D6 Landings	Access and egress to and from lift well landings must comply with the Deemed-to-Satisfy Provisions of Parts D2, D3 and D4.	Compliance Readily Achievable: Design statement to be provided at Construction Certificate stage.
E3D7 Passenger Lift types and their limitations	In an accessible building, every passenger lift must be one of the types identified in this clause, have accessible features in accordance with Table E3D8 and not rely on a constant pressure device for its operation if the lift car is fully enclosed.	Compliance Readily Achievable: Design statement to be provided at Construction Certificate stage.
E3D9 Fire Service Controls	In passenger lifts designed in accordance with AS 1735 Parts 1 and 2, all lift cars serving any storey above an effective height of 12m must be provided with fire service controls.	Compliance Readily Achievable: Design statement to be provided at Construction Certificate stage.
E3D11 Fire Service Recall Operation Switch	Each group of lifts must be provided with one fire service control switch (required by Clause E3D9 above) that activates the fire service recall operation. This clause details the switch, the labelling, the key and operation procedures for a fire service recall operation.	Compliance Readily Achievable: Design statement to be provided at Construction Certificate stage.
E3D12 Lift Car Fire Service Drive Control Switch	The lift car fire service drive control switch required by E3D9 must be activated from within the lift car. This clause details the switch, the initiation, the labelling and operation for the fire service drive control switch.	Compliance Readily Achievable: Design statement to be provided at Construction Certificate stage.
Part E4	Emergency Lighting, Exit Signage and Warning Systems	
E4D2 Emergency Lighting	This clause details when emergency lighting must be installed in Class 2 to 9 buildings. The requirements for buildings and parts of buildings are detailed in sub-clauses (a) to (i) and each sub-clause must be considered as	Compliance Readily Achievable: Design statement to be provided at Construction Certificate stage.

+ Clause	+ Reference	+ Comment
	more than one may apply to any single building.	
E4D3 Measurement of Distances	Distance, other than vertical rise, must be measured along the shortest path of travel whether by straight lines, curves or a combination of both.	Note: Compliance commentary only. No action is required in this regard.
E4D4 Design and Operation of Emergency Lighting	Every required emergency lighting system must comply with AS 2293.1 – 2018.	Compliance Readily Achievable: Design statement to be provided at Construction Certificate stage.
E4D5 Exit Signs	An exit sign must be clearly visible to persons approaching the exit and must be installed on, above or adjacent to each door providing egress from a building. Sub-clauses (a) to (d) set out the situations where exit signs are required to be installed.	Compliance Readily Achievable: Design statement to be provided at Construction Certificate stage.
E4D6 Direction Signs	If an exit is not readily apparent to persons occupying or visiting the building then exit signs must be installed in appropriate positions in corridors, hallways, lobbies, and the like, indicating the direction to a required exit.	Compliance Readily Achievable: Design statement to be provided at Construction Certificate stage.
E4D8 Design and Operation of Exit Signs	Every required exit sign must comply with AS/NZS 2293.1 - 2018 and be clearly visible at all times when the building is occupied by any person having the legal right of entry into the buildings.	Compliance Readily Achievable: Design statement to be provided at Construction Certificate stage.
E4D9 Emergency Warning Intercom System (EWIS)	Emergency Warning Intercom System (EWIS) complying with AS 1670.4 - 2018 must be installed— + In a building with an effective height of more than 25m.	Performance Solution: We assume the cascade of the EWIS may be rationalised to ensure a cascade of the fire alarm does not extend to Buildings 1A & 1B based on alarm activation in Building 2. Compliance Readily Achievable: Design statement to be provided at Construction Certificate stage.
Section F	Health and Amenity	
Part F1	Surface water management, rising damp and external waterproofing	
F1D3 Stormwater Drainage	Stormwater drainage must comply with AS/NZ 3500.3 – 2021 Note: The requirements of this clause do not apply to a balcony, podium or similar horizontal surface part of a building— + where the flooring is of timber decking or other perforated flooring; or	Compliance Readily Achievable: Design statement to be provided at Construction Certificate stage.

+ Clause	+ Reference	+ Comment
<p>F1D4 Exposed joints</p>	<ul style="list-style-type: none"> + which is located directly above ground. <p>Exposed joints in the drainage surface on a roof, balcony, podium or similar horizontal surface part of a building must—</p> <ul style="list-style-type: none"> + be protected in accordance with Section 2.9 of AS 4654.2; and + not be located beneath or run through a planter box, water feature or similar part of the building. <p>Note: The requirements of this clause do not apply to—</p> <ul style="list-style-type: none"> + a balcony, podium or similar horizontal surface part of a building— <ul style="list-style-type: none"> – where the flooring is of timber decking or other perforated flooring; or – which is located directly above ground. – A roof with a covering complying with F3D2(a) to (d). 	<p>Compliance Readily Achievable: Design statement to be provided at Construction Certificate stage.</p>
<p>F1D5 External waterproofing membranes</p>	<p>A roof, balcony, podium or similar horizontal surface part of a building must be provided with a waterproofing membrane—</p> <ul style="list-style-type: none"> + consisting of materials complying with AS 4654.1; and + designed and installed in accordance with AS 4654.2. <p>Note: The requirements of this clause do not apply to—</p> <ul style="list-style-type: none"> + a balcony, podium or similar horizontal surface part of a building— <ul style="list-style-type: none"> – where the flooring is of timber decking or other perforated flooring; or – which is located directly above ground. + A roof with a covering complying with F3D2(a) to (d). 	<p>Compliance Readily Achievable: Details to be provided at detailed design stage.</p>
<p>F1D6 Damp-proofing</p>	<p>Moisture from the ground must be prevented from reaching—</p> <ul style="list-style-type: none"> + the lowest floor timbers and the walls above the lowest floor joists; and + the walls above the damp-proof course; and + the underside of a suspended floor constructed of a material other than timber, and the supporting beams or girders. 	<p>Compliance Readily Achievable: Design statement to be provided at Construction Certificate stage.</p>

+ Clause	+ Reference	+ Comment
	The following buildings need not comply with the above:	
F1D7 Damp-proofing of floors on the ground	<p>If a floor of a room is laid on the ground or on fill, moisture from the ground must be prevented from reaching the upper surface of the floor and adjacent walls by the insertion of a vapour barrier in accordance with AS 2870.</p> <p>The above requirements do not apply where—</p> <ul style="list-style-type: none"> + weatherproofing is not required; + or the floor is the base of a stair, lift or similar shaft which is adequately drained by gravitation or mechanical means. 	<p>Compliance Readily Achievable:</p> <p>Design statement to be provided at Construction Certificate stage.</p>
Part F2	Wet Areas and Overflow Protection	
F2D2 Wet area construction	This clause requires that wet areas in Class 2 to 9 buildings must be waterproofed. It prescribes the standards to which the work must be carried on the construction of rooms containing urinals and their installation.	<p>Compliance Readily Achievable:</p> <p>Details to be provided at detailed design stage.</p>
F2D3 Rooms containing urinals	Where a urinal is installed within a building, this clause contains design requirements around the requirements for floor wastes and impervious wall and floor surfaces.	<p>Note:</p> <p>Compliance commentary only. No action is required in this regard.</p>
F2D4 Floor wastes	<ul style="list-style-type: none"> + In a Class 2 or 3 building or Class 4 part of a building, a bathroom or laundry located at any level above a sole-occupancy unit or public space must have a floor waste. + Where a floor waste is installed— + The minimum continuous fall of a floor plane to the waste must be 1:80; and + The maximum continuous fall of a floor plane to the waste must be 1:50. 	<p>Compliance Readily Achievable:</p> <p>Details to be provided at detailed design stage.</p>
Part F3	Roof and Wall Cladding	
F3D2 Roof coverings	<p>A roof must be covered with—</p> <ul style="list-style-type: none"> + roof tiles complying with AS 2049, fixed in accordance with AS 2050; or + metal sheet roofing complying with AS 1562.1; or + plastic sheet roofing designed and installed in accordance with AS 1562.3; or + terracotta, fibre-cement and timber slates and shingles designed and installed in accordance with AS 4597, except in cyclonic areas; or + an external waterproofing membrane complying with F1D5. 	<p>Compliance Readily Achievable:</p> <p>Design statement to be provided at Construction Certificate stage.</p>

+ Clause	+ Reference	+ Comment
F3D3 Sarking	Sarking-type materials used for weatherproofing of roofs must comply with AS/NZS 4200 parts 1 and 2.	Compliance Readily Achievable: Details to be included into the design.
F3D4 Glazed assemblies	<p>The following glazed assemblies in an <i>external wall</i>, must comply with AS 2047 requirements for resistance to water penetration:</p> <ul style="list-style-type: none"> + Windows. + Sliding and swinging glazed doors with a frame, including French and bi-fold doors with a frame. + Adjustable louvres. + Shopfronts. + Window walls with one piece framing. <p>The following buildings need not comply with:</p> <ul style="list-style-type: none"> + A Class 7 or 8 building where in the particular case there is no necessity for compliance. + A garage, tool shed, sanitary compartment, or the like, forming part of a building used for other purposes, except where the construction of the garage, tool shed, sanitary compartment or the like contributes to the weatherproofing of the other part of the building. + An open spectator stand or open-deck carpark. <p>The following glazed assemblies need not comply:</p> <ul style="list-style-type: none"> + All glazed assemblies not in an external wall. + Revolving doors. + Fixed louvres. + Skylights, roof lights and windows in other than the vertical plane. + Sliding and swinging glazed doors without a frame. + Windows constructed on site and architectural one-off windows, which are not design tested in accordance with AS 2047. + Second-hand windows, re-used windows and recycled windows. Heritage windows. 	Compliance Readily Achievable: Details to be included into the design.

+ Clause	+ Reference	+ Comment
<p>F3D5 Wall cladding</p>	<p>External wall cladding must comply with one or a combination of the following:</p> <ul style="list-style-type: none"> + Masonry, including masonry veneer, unreinforced and reinforced masonry: AS 3700. + Autoclaved aerated concrete: AS 5146.3. + Metal wall cladding: AS 1562.1. <p>The following buildings need not comply:</p> <ul style="list-style-type: none"> + A Class 7 or 8 building where in the particular case there is no necessity for compliance. + A garage, tool shed, sanitary compartment, or the like, forming part of a building used for other purposes, except where the construction of the garage, tool shed, sanitary compartment or the like contributed to the weatherproofing of another part of the building that is required to be weatherproofed. + An open spectator stand or open deck carpark. 	<p>Performance Solution:</p> <p>A performance solution report may be required to be prepared to Performance Requirement F3P1 in relation to weatherproofing of external walls.</p> <p>This may be through Verification Method F3V1, or an alternative suitable method.</p> <p>This will be required from the Façade Engineer.</p>
Part F4		Sanitary and Other Facilities
<p>F4D2 Facilities in Residential Buildings</p>	<p>In a Class 3 other than residential care buildings:</p> <ul style="list-style-type: none"> + Provide a bath / shower, a closet pan and washbasin for each 10 residents + If one urinal is provided for each 25 males up to 50 and one additional urinal for each additional 50 males or part thereof, one closet pan for each 12 males may be provided. + Facilities for employees provided in relation with F24D4. + Facilities mentioned above do not be located in the same building. 	<p>Further Information Required:</p> <p>Provide details of where student accommodation staff sanitary facilities will be provided.</p> <p>Complies:</p> <p>Each class 3 SOU is provided with a bath/shower, closet pan and washbasin</p>
<p>F4D3 Calculation of Number of Occupants and Fixtures</p>	<p>This clause sets out the requirements for the calculation of the number of occupants and the number of sanitary facilities required to be installed in Class 2 to 9 buildings.</p>	<p>Compliance Readily Achievable:</p> <p>Details to be included into the design.</p>
<p>F4D4 Facilities in Class 3 to 9 buildings</p>	<p>This clause provides the requirements for sanitary facilities to be installed in Class 3, 5, 6, 7, 8 buildings.</p> <p>When accessible sanitary facilities are provided, they account once for each sex.</p> <p>Unisex sanitary compartments (other than strictly unisex accessible sanitary facilities) are not permitted for use, other than solely</p>	<p>Compliance Readily Achievable:</p> <p>The level 1 and 2 childcare sanitary facilities numbers comply.</p> <p>The retail sanitary facilities calculation has been combined between Building 1 and 2. The combined sanitary facilities on the</p>

+ Clause	+ Reference	+ Comment
	<p>by staff in circumstances where not more than 10 persons are employed.</p> <p>A Class 9b early childhood centre must be provided with—</p> <ul style="list-style-type: none"> + a kitchen or food preparation area with a kitchen sink, separate hand washing facilities, space for a refrigerator and space for cooking facilities, with— <ul style="list-style-type: none"> – the facilities protected by a door or gate with child proof latches to prevent unsupervised access to the facilities by children younger than 5 years old; and – the ability to facilitate supervision of children from the facilities if the early childhood centre accommodates children younger than 2 years old; and + one bath, shower or shower-bath; and + if the centre accommodates children younger than 3 years old— <ul style="list-style-type: none"> – a laundry facility comprising a washtub and space in the same room for a washing machine; and – a bench type baby bath, which is within 1 m of the nappy change bench; and – a nappy changing bench which— <ul style="list-style-type: none"> ▪ is within 1 m of separate adult hand washing facilities and bench type baby bath; and ▪ must be not less than 0.9m² in area and at a height of not less than 850mm, but not more than 900mm above the finished floor level; and ▪ must have a space not less than 800mm high, 500mm wide and 800mm deep for the storage of steps; and ▪ is positioned to permit a staff member changing a nappy to have visibility of the play area at all times. 	<p>ground floor can accommodate a retail population of up to 1,200 people.</p> <p>We understand the retail staff will utilise the basement EOT facilities. These facilities can accommodate a staff population of up to 80 people. If additional staff needs to be accommodated the retail patron population will need to be reduced</p> <p>Performance Solution:</p> <p>To allow the childcare staff sanitary facilities to be unisex.</p> <p>The childcare kitchen area is not capable of facilitating supervision of children younger than 2 years hold.</p> <p>Compliance Readily Achievable:</p> <p>Details to be included into the design for childcare centre requirements for kitchen, laundry, bath and nappy changing bench.</p>

+ Ground Floor – Retail Patrons (up to 1,200)

Occupancy Class as per F4D4

	Closet Pans		Urinals		Washbasins		Complies
	Required	Proposed	Required	Proposed	Required	Proposed	Yes/No
Male	4	2+3+2=7	9	2+6=8	TBC	6	Yes
Female	10	3+6+2=10	-	-	TBC	6	Yes

+ Clause	+ Reference	+ Comment
----------	-------------	-----------

Note 1: The accessible toilet facilities have been counted once for each sex in accordance with BCA clause F4D3.

+ Ground Floor – Retail Staff							
Occupancy Class as per F4D4							
	Closet Pans		Urinals		Washbasins		Complies
	Proposed	Pop. Served	Proposed	Pop. Served	Proposed	Pop. Served	Yes/No
Male	2	40	2	40	2	40	TBC
Female	3	40	-	-	2	40	TBC

Note 1: It is understood that retail staff are to rely upon the basement EOT facilities.

Note 2: The accessible toilet facilities have been counted once for each sex in accordance with BCA clause F4D3.

+ Childcare							
131 children							
23 staff							
Occupancy Class as per F4D4							
	Closet Pans		Urinals		Washbasins		Complies
	Required	Proposed	Required	Proposed	Required	Proposed	Yes/No
Staff	2	2	-	-	2	2	Yes
Children	9	14	-	-	10	10	Yes

Note 1: The accessible toilet facilities have been counted once for each sex for staff in accordance with BCA clause F4D3.

F4D5 Accessible Sanitary Facilities	Accessible unisex sanitary compartments must be provided, in accordance with F4D6 and unisex showers must be provided in accordance with Table F4D7, in buildings or parts that are required to be accessible.	Refer to our access assessment in Section 4.0 of this report.
F4D8 Construction of Sanitary Compartments	<p>Other than in an early childhood centre, sanitary compartments must have doors and partitions that separate adjacent compartments and extend –</p> <ul style="list-style-type: none"> + from floor level to the ceiling in the case of a unisex facility; or + a height of not less than 1.5m above the floor if primary school children are the principal users; or + 1.8m above the floor in all other cases. <p>The door to a fully enclosed sanitary compartment must open outwards; or slide: or be readily removable from the outside of the sanitary compartment, unless there is a clear space of at least 1.2m, measured in accordance with Figure F4D8 between the closet pan within the sanitary compartment and the doorway.</p>	

+ Clause	+ Reference	+ Comment
<p>F4D9 Interpretation: Urinals and Wash Basins</p>	<p>A urinal may be an individual stall or wall-hung urinal, each 600mm length of a continuous urinal trough or a closet pan used in place of a urinal.</p> <p>A washbasin may be an individual basin or a part of a hand washing trough served by a single water tap.</p>	<p>Note: Compliance commentary only. No action is required in this regard.</p>
<p>Part F1 Room Heights</p>		
<p>F5D2 Height of Rooms and Other Spaces.</p>	<p>The ceiling heights are prescribed and should be checked for all classes and parts during assessment or the design process.</p> <p>The ceiling minimum heights for a Class 3 building are as follows:</p> <ul style="list-style-type: none"> + Kitchen, laundry or the like – 2.1m + Corridor or passageway – 2.1m + A habitable room, excluding kitchen – 2.4m <p>The minimum ceiling heights in a Class 6 building are as follows:</p> <ul style="list-style-type: none"> + Generally – 2.4m. + Corridor, passageways, or the like – 2.1m. <p>The minimum ceiling heights in a Class 9b building are as follows:</p> <ul style="list-style-type: none"> + School classroom, or other assembly building or part accommodating not more than 100 persons – 2.4m. + Theatre, public hall, or other assembly building or part accommodating more than 100 persons – 2.7m. <p>In any building:</p> <ul style="list-style-type: none"> + Bathrooms, sanitary compartments, tea preparations rooms, pantries, store rooms or the like – 2.1m, + A commercial kitchen – 2.4m, + Above a stairway, ramp, landing or the like – 2m. 	<p>Compliance Readily Achievable: Details to be provided at detailed design stage.</p>
<p>F6D2 Provision of Natural Light</p>	<p>Natural lighting must be provided in:</p> <ul style="list-style-type: none"> + Class 3 buildings — to all bedrooms and dormitories. + Class 9b buildings — to all general purpose classrooms in primary or secondary schools and all playrooms or the like for the use of children in an early childhood centre. 	<p>Compliance Readily Achievable: Design statement to be provided at Construction Certificate stage.</p> <p>Note: Class 3 - all habitable rooms appear to have a natural light provision.</p> <p>Note: Class 9b childcare - all playrooms or the like appear to have a natural light provision.</p>

+ Clause	+ Reference	+ Comment
<p>F6D3/F6D4 Method and Extent of Achieving Natural Lighting</p>	<p>Windows or the like are to have an aggregate light transmitting area of not less than 10% of the floor area of the room.</p> <p>In a Class 3 or 9 building a required window that faces a boundary of an adjoining allotment or a wall of the same building or another building on the allotment must not be less than a horizontal distance from that boundary or wall that is the greater of—</p> <ul style="list-style-type: none"> + generally — 1m; and + 50% of the square root of the exterior height of the wall in which the window is located, measured in metres from its sill. <p>In a Class 9b early childhood centre, the sills of 50% of windows in children's rooms must be located not more than 500mm above the floor level.</p>	<p>Compliance Readily Achievable: Design statement to be provided at Construction Certificate stage.</p>
<p>F6D5 Artificial Lighting</p>	<p>Artificial lighting must be provided in required stairways, passageways, and ramps and where natural light is insufficient. The artificial lighting system must comply with AS/NZS 1680.0.</p> <p>Windows or the like are to have an aggregate light transmitting area of not less than 10% of the floor area of the room.</p> <p>In the 9c building windows must be transparent and located in an external wall with a windowsill not higher than 1.0m above the floor level and where the window faces an allotment, another building or structure, it must not be located less than 3m away to maintain amenity to the space. In this regard compliance is readily achieved.</p> <p>Artificial lighting must be provided where occupants seeking egress in an emergency, in—</p> <ul style="list-style-type: none"> + Class 3 and 9 buildings — to all rooms that are frequently occupied, all spaces required to be accessible, all corridors, lobbies, internal stairways, other circulation spaces and paths of egress. 	<p>Compliance Readily Achievable: Design statement to be provided at Construction Certificate stage.</p>
<p>F6D6 Ventilation of Rooms</p>	<p>A habitable room, office, shop, factory, workroom, sanitary compartment, bathroom, shower room, laundry and any other room occupied by a person for any purpose must have natural ventilation complying with F6D7 or a mechanical or air-conditioning system complying with AS1668.2 and AS/NZS 3666.1.</p>	<p>Compliance Readily Achievable: Design statement to be provided at Construction Certificate stage.</p>

+ Clause	+ Reference	+ Comment
	<p><i>Note: NSW F6D6 – a mechanical ventilation or air-conditioning system complying with AS 1668.2 – the reference to AS/NZS 3666.1 is deleted from the BCA in NSW as the need to comply with this standard is regulated under the relevant section of the Public Health Act 1991.</i></p>	
<p>F6D7 Natural Ventilation</p>	<p>Natural ventilation must consist of openings, windows, doors or other devices which can be opened— with a ventilating area not less than 5% of the floor area of the room required to be ventilated. Additionally, open to a suitably sized space open to the sky or an adjoining room in accordance with F6D8.</p>	<p>Compliance Readily Achievable: Design statement to be provided at Construction Certificate stage.</p>
<p>F6D8 Ventilation Borrowed from Adjoining Rooms</p>	<p>Natural ventilation to a room may come through a window, opening ventilating door or other device from an adjoining room (including an enclosed verandah) if both rooms are within a sole-occupancy unit or the enclosed verandah is common property and be carried out in accordance with the requirements of sub-clauses (a), (b) & (c).</p>	<p>Note: Compliance commentary only. No action is required in this regard.</p>
<p>F6D9 Restriction on Position of Water Closets and Urinals</p>	<p>A room containing a water closet pan or urinal must not open directly into a kitchen or pantry, public dining room or restaurant, a dormitory in a Class 3 building, a room used for public assembly (which is not an early childhood centre, primary school or open spectator stand) or a workplace normally occupied by more than 1 person.</p>	<p>Complies: Sanitary facilities on the ground floor and childcare open into corridors.</p>
<p>F6D10 Airlocks</p>	<p>If a sanitary compartment is prohibited under F6D9 from opening directly to another room—</p> <ul style="list-style-type: none"> + in a sole-occupancy unit in a Class 2 or 3 building or Class 4 part of a building— <ul style="list-style-type: none"> - access must be by an airlock, hallway or other room; or - the sanitary compartment must be provided with mechanical exhaust ventilation; and + in a Class 5, 6, 7, 8 or 9 building (which is not an early childhood centre, primary school or open spectator stand)— <ul style="list-style-type: none"> - access must be by an airlock, hallway or other room with a floor area of not less than 1.1m² and fitted with self-closing doors at all access doorways; or - the sanitary compartment must be provided with mechanical exhaust ventilation and the doorway to the room adequately screened from view. 	<p>Not applicable.</p>

+ Clause	+ Reference	+ Comment
F6D12 Kitchen Local Exhaust Ventilation	A commercial kitchen must be provided with a kitchen exhaust hood complying with AS 1668.1 and 1668.2.	Compliance Readily Achievable: Design statement to be provided at Construction Certificate stage.
Part F7 Sound Transmission and Insulation		
F7D4 Determination of Impact Sound Insulation Ratings	<p>A floor must have the required value for weighted normalised impact sound pressure level with spectrum adaptation term ($L_{n,w}$) determined in accordance with AS ISO 717.2 using results from laboratory measurements, or comply with Spec. 28.</p> <p>For a Class 2 building a wall must of discontinuous construction.</p> <p>For a class 9c building a wall must, for other than masonry, be two or more separate leaves without rigid mechanical connection except at the periphery, or be identical with a prototype that is no less resistant to the transmission of impact sound when tested than a wall listed in Spec. 28.</p>	Compliance Readily Achievable: Design statement and Acoustic Report to be provided at Construction Certificate stage.
F7D5 Sound Insulation Rating of Floors	<p>A floor in a Class 2 & 3 building must have an $R_w + C_{tr}$ (airborne) not less than 50 and an $L_{n,w}$ (impact) not more than 62.</p> <p>A floor in a Class 9c building separating sole-occupancy units must have an R_w of not less than 45.</p>	Compliance Readily Achievable: Design statement and Acoustic Report to be provided at Construction Certificate stage.
F7D6 Sound Insulation Rating of Walls	<p>A wall separating a sole occupancy unit from another part of the building must have an airborne sound insulation rating of not less than 50 and be provided with discontinuous construction if it separates a bathroom, sanitary compartment, laundry, kitchen in another sole occupancy unit or a plant room or lift shaft.</p> <p>A door that separates a sole occupancy unit from a public corridor must have a weighted sound reduction index of not less than 30.</p> <p>For a class 9c building, a wall must have an R_w not less than 45 if it separates SOUs, or a SOU from a kitchen, bathroom, sanitary compartment (excluding an ensuite), laundry, plant room, or utilities room.</p> <p>Where a wall is required to have sound insulation and has a floor or roof above, the wall must continue to the underside of the floor or roof above, or a ceiling that provides the sound insulation required for the wall.</p>	Compliance Readily Achievable: Design statement and Acoustic Report to be provided at Construction Certificate stage.

+ Clause	+ Reference	+ Comment
F7D7 Sound Insulation Rating of Internal Services	<p>If a duct, soil, waste or water supply pipe, including a duct or pipe that is located in a wall or floor cavity, serves or passes through more than one SOU, the duct or pipe must be separated from the rooms of an SOU by construction with a $R_w + C_{tr}$ (airborne) not less than-</p> <ul style="list-style-type: none"> + 40 if the adjacent room is a habitable room (other than a kitchen); or + 25 if the adjacent room is a kitchen or non-habitable room. <p>If a stormwater pipe passes through a SOU, it must also be separated in accordance with this clause.</p>	<p>Compliance Readily Achievable: Design statement and Acoustic Report to be provided at Construction Certificate stage.</p>
F7D8 Sound Isolation of Pumps	<p>A flexible coupling must be used at the point of connection between the service pipes in a building and any circulating or other pump.</p>	<p>Compliance Readily Achievable: Design statement and Acoustic Report to be provided at Construction Certificate stage.</p>
Section G Ancillary Provisions		
Part G1 Minor Structures and Components		
G1D3 Refrigerated Chambers, Strong Rooms and Vaults	<p>A refrigerated or cooling chamber, strongroom or vault which is of sufficient size for a person to enter must be capable of being opened from the inside by hand without a key. This clause also sets out the acceptable safety standards for a cooling chamber or strongroom by installation of dedicated controls within the chamber and the external lights that indicate that the space is in use. Additionally, a door in a cooling chamber must have a doorway with a clear width of at least 600mm and a clear height of at least 1.5m.</p>	<p>Compliance Readily Achievable: Details to be provided at detailed design stage.</p>
G1D4 Outdoor Play Spaces	<p>Any outdoor play space in a Class 9b early childhood centre must be enclosed on all sides with a barrier which—</p> <ul style="list-style-type: none"> + where the edge of the trafficable surface of the outdoor play space is at the same level or less than 2m above the surface beneath — complies with AS 1926.1; and + where the edge of the trafficable surface of the outdoor play space is 2m or more above the surface beneath— <ul style="list-style-type: none"> - is not less than 1.8m high, as measured from above the trafficable surface; and - is non-climbable and does not contain horizontal or other elements that could facilitate climbing; and 	<p>Compliance Readily Achievable: Details to be provided at detailed design stage.</p>

+ Clause	+ Reference	+ Comment
	<ul style="list-style-type: none"> - does not have any openings or apertures through which a 100mm or greater sphere could pass; and - is not within 1.8m, as measured directly from the top of the barrier, of any elements within the outdoor play space that facilitate climbing; and - Is not within 900mm of elements in a wall that facilitate climbing; and <p>+ has strength and rigidity complying with AS 1926.1.</p> <p>For the purposes of compliance with AS 1926.1, this is applied as if there is a swimming pool located outside the outdoor play space, so that the barrier restricts children from exiting the premises without the knowledge of staff in the centre.</p> <p>The above requirements of do not apply to a wall, including doors and windows, which form part of the Class 9b early childhood centre, except where the wall is within a non-climbable zone.</p>	
<p>NSW G1D5 Provision for Cleaning of Windows</p>	<p>A building must provide for a safe manner of cleaning any windows located 3 or more storeys above ground level.</p> <p>A building satisfies this requirement where the windows can be cleaned wholly from within the building; or provision is made for the cleaning of the windows by a method complying with the Work Health and Safety Act 2011 and regulations made under that Act.</p>	<p>Compliance Readily Achievable: Details to be included into the design.</p>
<p>Part G2</p>	<p>Boilers, Pressure Vessels, Heating Appliances, Fireplaces, Chimneys and Flues</p>	
<p>G2D2 Installation of Appliance</p>	<p>Domestic solid-fuel burning appliances must comply with AS/NZS 2918.</p> <p>Boilers and pressure vessels must comply with Spec. 30.</p>	<p>Further Information Required: Confirm if boilers or pressure vessels are proposed.</p>
<p>Part G6</p>	<p>Occupiable Outdoor Areas</p>	
<p>G6D1 Application of Part</p>	<p>The Deemed-to-Satisfy Provisions of this Part apply to buildings containing an occupiable outdoor area in addition to the other Deemed-to-Satisfy Provisions of the BCA.</p> <p>The Deemed-to-Satisfy Provisions of this Part take precedence where there is a difference to the Deemed-to-Satisfy Provisions of Sections C, D, E, F and G.</p> <p>Except for G6D2, the Deemed-to-Satisfy Provisions of this Part do not apply to—</p>	<p>Compliance Readily Achievable: Details to be provided at detailed design stage.</p>

+ Clause	+ Reference	+ Comment
	<ul style="list-style-type: none"> + an occupiable outdoor area of a sole-occupancy unit in a Class 2 or 3 building, Class 9c building or Class 4 part of a building; or + an occupiable outdoor area with an area less than 10m². 	
G6D2 Fire Hazard Properties	<p>Subject to the below, a lining, material or assembly in an occupiable outdoor area must comply with C2D11 as for an internal element.</p> <p>The following fire hazard properties of a lining, material or assembly in an occupiable outdoor area are not required to comply with C2D11:</p> <ul style="list-style-type: none"> + Average specific extinction area. + Smoke-Developed Index. + Smoke development rate + Smoke growth rate index 	<p>Compliance Readily Achievable: Details to be provided at detailed design stage.</p>
G6D3 Fire Separation	<p>For the purposes of the Deemed-to-Satisfy Provisions of C3D8, C3D9, C3D10, a reference to a storey includes an occupiable outdoor area, however a fire wall cannot be used to separate an occupiable outdoor area into different fire compartments.</p>	<p>Compliance Readily Achievable: Details to be provided at detailed design stage.</p>
G6D4 Provision of Escape	<p>For the purposes of the Deemed-to-Satisfy Provisions of Part D2, a reference to a storey or room includes an occupiable outdoor area.</p>	<p>Complies</p>
G6D5 Construction of Exits	<p>For the purposes of the Deemed-to-Satisfy Provisions of Part D3, a reference to a storey or room includes an occupiable outdoor area.</p>	<p>Compliance Readily Achievable: Details to be provided at detailed design stage.</p>
G6D6 Fire Fighting Equipment	<p>Except for S17C7(2)(a), for the purposes of the Deemed-to-Satisfy Provisions of Part E1, a reference to a storey includes an occupiable outdoor area.</p>	<p>Compliance Readily Achievable: Details to be provided at detailed design stage.</p>
G6D7 Lift Installations	<p>For the purposes of the Deemed-to-Satisfy Provisions of Part E3, a reference to a storey includes an occupiable outdoor area.</p>	<p>Compliance Readily Achievable: Details to be provided at detailed design stage.</p>
G6D8 Visibility in an Emergency, Exit Signs, and Warning Signs	<p>For the purposes of the Deemed-to-Satisfy Provisions of Part E4, a reference to a storey includes an occupiable outdoor area.</p>	<p>Compliance Readily Achievable: Detail to be included in the design. Ensure exit and emergency lighting comply within occupiable outdoor areas as if they were internal areas.</p>
Part G7	Livable Housing Design	
NSW G7	<p>Part G7 does not apply in NSW as livable housing design requirements do not apply to</p>	<p>Note: Not Applicable in NSW.</p>

+ Clause	+ Reference	+ Comment
Livable Housing Design	sole-occupancy units in a Class 2 building in NSW.	
Section J Energy Efficiency		
J1V3 Verification Using a Reference Building	Verification using referenced building.	Compliance Readily Achievable: We understand that a J1V3 report may be provided to achieve compliance in accordance with Section J.
Part J3 Elemental Provisions for a SOU of a Class 2 building or Class 4 part	This Part contains Deemed-to-Satisfy Provisions (elemental) for compliance with Part J1. It sets out provisions for the insulation of building fabric and the energy efficiency of domestic services of a sole-occupancy unit of a Class 2 building or a Class 4 part of a building.	Compliance Readily Achievable: Design statement and Section J Report to be provided at Construction Certificate stage.
Part J4 Building Fabric	This Part contains Deemed-to-Satisfy Provisions for compliance with Part J1. It sets out provisions for the building envelope including roofs, ceilings, roof lights, walls, glazing and floors.	Compliance Readily Achievable: Design statement and Section J Report to be provided at Construction Certificate stage.
Part J5 Building Sealing	This Part contains Deemed-to-Satisfy Provisions for compliance with Part J1. It sets out provisions for the sealing of a building's glazing, doors, exhaust fans and the like in order to increase thermal comfort for occupants and reduce the energy consumption of any installed air-conditioning systems.	Compliance Readily Achievable: Design statement and Section J Report to be provided at Construction Certificate stage.
Part J6 Air-conditioning and ventilation	This Part contains Deemed-to-Satisfy Provisions for compliance with Part J1. It sets out the provisions for the efficiency and control of air-conditioning, space heating and ventilation equipment, the efficiency, sealing and insulation requirements for ductwork systems containing fans, and for the efficiency and insulation of pipework and pump systems.	Compliance Readily Achievable: Design statement and Section J Report to be provided at Construction Certificate stage.
Part J7 Artificial lighting and power	This Part contains Deemed-to-Satisfy Provisions for compliance with Part J1. It sets out provisions for the design and configuration of artificial lighting and power, boiling and chilled water units, lifts and escalators and moving walkways.	Compliance Readily Achievable: Design statement and Section J Report to be provided at Construction Certificate stage.
Part J8 Heated Water Supply and Swimming Pool and Spa Pool Plant	This Part contains Deemed-to-Satisfy Provisions for compliance with Part J1. It sets out provisions for ensuring water heaters, swimming pool and spa heaters and pump systems use energy efficiently.	Compliance Readily Achievable: Design statement and Section J Report to be provided at Construction Certificate stage.
Part J9	This Part contains Deemed-to-Satisfy Provisions for compliance with Part J1. It	Compliance Readily Achievable:

+ Clause	+ Reference	+ Comment
Energy monitoring and on-site distributed energy resources	sets out provisions that enable the monitoring of energy use (other than for billing purposes) and facilitate easy retrofit of renewable energy and electric vehicle charging equipment.	Design statement and Section J Report to be provided at Construction Certificate stage.

4.0 DDA, BCA Part D4 & AS1428.1-2021 Assessment

4.1 DDA, BCA, BCA Part D4 & AS 1428.1-2021 Assessment

+ Clause	+ Reference	+ Comment
Section D		Access and Egress
Part D4		Access for people with a disability
D4D2 (Previously D3.1) General building access requirements	<p>Buildings and parts of buildings must be accessible as required by this clause, unless exempted by D4D5.</p> <p>(5) For a Class 3 building, access requirements are as follows:</p> <p>(a) Common areas:</p> <p>(i) From a pedestrian entrance required to be accessible to at least 1 floor containing sole-occupancy units and to the entrance doorway of each sole-occupancy unit located on that level.</p> <p>(ii) To and within not less than 1 of each type of room or space for use in common by the residents, including a cooking facility, sauna, gymnasium, swimming pool, common laundry, games room, TV room, individual shop, dining room, public viewing area, ticket purchasing service, lunch room, lounge room, or the like.</p> <p>(iii) Where a ramp complying with AS 1428.1 or a passenger lift is installed—</p> <p>(A) to the entrance doorway of each sole-occupancy unit; and</p> <p>(B) to and within rooms or spaces for use in common by the residents.</p> <p>(iv) The requirements of (iii) only apply where the space referred to in (A) and (B) are located on the levels served by the lift or ramp.</p> <p>(b) Sole-occupancy units — in accordance with Table D4D2b.</p> <p>For Class 6 buildings, access must be provided to and within all areas normally used by the occupants.</p> <p>For a Class 9b building, access requirements are as follows:</p> <p>(a) Schools and early childhood centres — to and within all areas normally used by the occupants.</p> <p>(b) An assembly building, not being a school or early childhood centre—to and within—</p> <p>(i) wheelchair seating spaces provided in accordance with D4D10; and</p>	<p>Performance Solution:</p> <p>To rationalise the requirements relating to accessible class 3 SOU's. The two potential options for the performance solution are:</p> <p>Option 1:</p> <ul style="list-style-type: none"> + 5x fully accessible rooms (i.e. wheelchair users) + 14x accessible rooms to consider other accessible needs. <p>Option 2:</p> <ul style="list-style-type: none"> + 3x fully accessible rooms (i.e. wheelchair users) + 16x accessible rooms to consider other accessible needs with 5-7x rooms being <i>readily adaptable</i>. <p>Compliance Readily Achievable:</p> <p>Details to be developed and provided at Design Development stage.</p> <p>Note: Based on initial advice we understand that the accessible unit are 'representative of the range of rooms available'. The building operator has confirmed that the price of accessible units will be the same as a standard room (not premium) and the Architect will provide advice that other considerations such as amenity, available views etc. are representative of a range of rooms available.</p>

+ Clause	+ Reference	+ Comment
----------	-------------	-----------

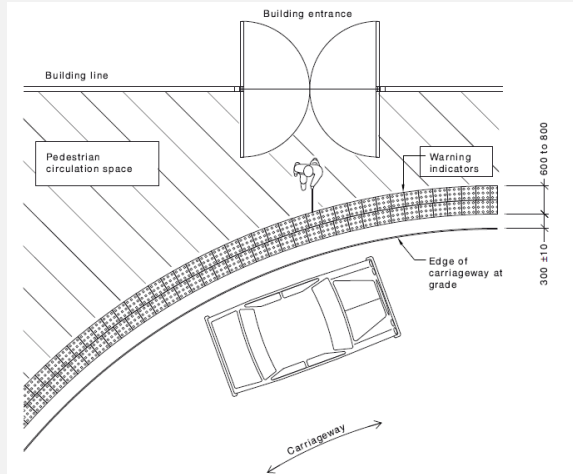

Figure 25(A)

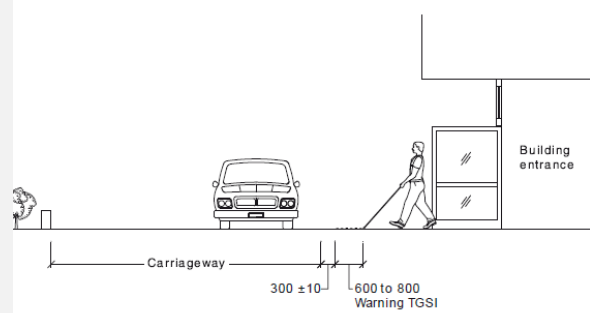

Figure 25(A)

D4D4 (Previously D3.3) Parts of buildings to be accessible	The works are required to comply with the requirements of AS 1428.1-2009.	Compliance Readily Achievable: Details to be developed and provided at Design Development stage.
AS1428.1 Cl. 6.1 General	A continuous accessible path of travel shall not include a step, stairway, turnstile, revolving door, escalator, moving walk or other impediment.	Compliance Readily Achievable: No impediments have been noted in the current design.
AS1428.1 Cl. 6.2 Height of paths	The minimum unobstructed height of a continuous accessible path of travel shall be 2000 mm or 1980 mm at doorways	Compliance Readily Achievable: Details to be incorporated into the design.
AS1428.1 Cl. 6.3 Widths of paths	Unless otherwise specified (such as at doors, curved ramps and similar), the minimum unobstructed width of a continuous accessible path of travel shall be 1000 mm and the following shall not intrude into the minimum unobstructed width of a continuous accessible path of travel: <ul style="list-style-type: none"> + Fixtures and fittings such as lights, awnings, windows that, when open, intrude into the circulation space, telephones, skirtings and similar objects. + Essential fixtures and fittings such as fire hose reels, fire extinguishers and switchboards. + Door handles less than 900 mm above the finished floor level. 	Compliance Readily Achievable: Details to be incorporated into the design. The terrace outdoor dining areas along Grit Lane must maintain a >1m clear width and provide 90 degree turns at corners when taking into consideration the furniture layout.
AS1428.1 Cl. 6.4 Passing Space	Accessways must have passing spaces complying with AS 1428.1 at maximum 20m intervals on those parts of an accessway where a direct line of sight is not available.	Compliance Readily Achievable: Passing space appears to be achievable for corridors longer than 20m where a direct line of sight

+ Clause	+ Reference	+ Comment
		<p>doesn't occur for level 3-25 of the building.</p>
<p>AS1428.1 Cl. 6.5 Turning Space</p>	<p>Turning spaces must comply with AS1428.1 and located within 2m of the end of accessways where it is not possible to continue travelling along the accessway, and at maximum 20m intervals along the accessway.</p> <p>(a) Space required in corridor (b) Space required in corridor</p>	<p>Compliance Readily Achievable: Turnaround space is provided on level 1, 2, and 4-23.</p> <p>Details to be developed to verify turnaround space on other levels.</p>
<p>AS1428.1 Cl. 7 Floor Transition/s</p>	<p><u>Tolerances for Abutment of Surfaces:</u> Transitions between floor finishes will need to comply with Clause 7.2 of AS1428.1-2009.</p> <p><u>Recessed / Soft Floor Coverings:</u></p> <ul style="list-style-type: none"> + Pile height or pile thickness shall not exceed 11mm and the carpet backing thickness shall not exceed 4mm. + Exposed edges of floor coverings be fastened to the floor with a trim along any exposed edges. + At leading edges, carpet or other soft materials shall have a vertical face no higher than 3mm or a rounded bevelled edge no higher than 5mm. Up to 10mm is permitted at a 1:8 gradient. + Recessed matting must be no more than a 3mm vertical, or 5mm rounded, proud of the adjacent floor surface. This also applies when the matting is depressed below surface level. <p><u>Grates:</u> Grates shall comply with the following:</p> <ul style="list-style-type: none"> + Circular openings shall be not greater than 13 mm in diameter. + Slotted openings shall be not greater than 13 mm wide and be oriented so that the long dimension is transverse to the dominant direction of travel. 	<p>Compliance Readily Achievable: Details to be incorporated into the design.</p>

+ Clause	+ Reference	+ Comment
----------	-------------	-----------

NOTE: Where slotted openings are less than 8 mm, the length of the slots may continue across the width of paths of travel.

Tolerances for Abutment of Surfaces:

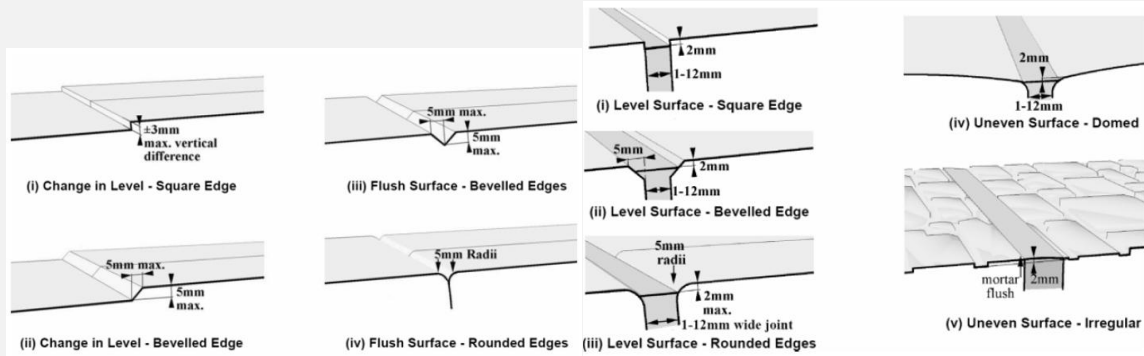

AS1428.1
Cl. 11.1
Stairway
Construction

- + Where the intersection is at the property boundary, the stair shall be set back by a minimum of 900 mm so that the handrail (complying with Clause 12) and TGSIs do not protrude into the transverse path of travel.
- + Where the intersection is at an internal corridor, the stair shall be set back so that handrails or TGSIs do not protrude in to the path of travel.
- + Stairs shall have opaque risers.
- + Stair nosings shall not project beyond the face of the riser and the riser may be vertical or have a splay backwards up to a maximum 25 mm.
- + Stair nosing profiles shall—
 - have a sharp intersection;
 - be rounded up to 5 mm radius; or
 - be chamfered up to 5 mm × 5 mm.
- + At the nosing, each tread shall have a strip not less than 50 mm and not more than 75 mm deep across the full width of the path of travel. The strip may be set back a maximum of 15 mm from the front of the nosing. The strip shall have a minimum luminance contrast of 30% to the background. Where the luminous contrasting strip is affixed to the surface of the tread, any change in level shall comply with Clause 7.2 and Clause 7.3.
- + Where the luminance contrasting strip is not set back from the front of the nosing then any area of luminance contrast shall not extend down the riser more than 10 mm.
- + TGSIs shall be installed in accordance with AS 1428.4.1.

Compliance Readily Achievable:

Details to be developed and provided at Design Development stage.

+ Clause	+ Reference	+ Comment
----------	-------------	-----------

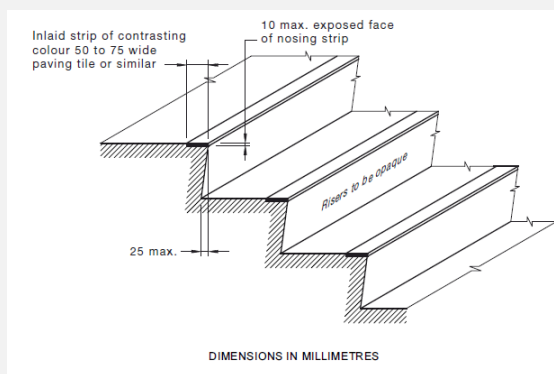

Example of Compliant Nosing Strip Detail

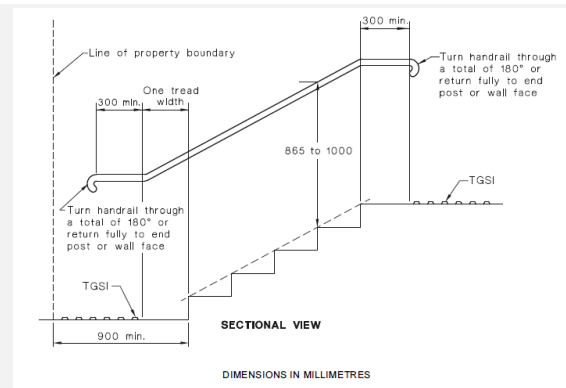

Example of Compliant Stairway Design

AS1428.1
Cl. 11.2
Stairway
Handrails

Handrails shall be continuous throughout the stair flight and, where practicable, around landings and have no obstruction on or above up to a height of 600 mm and as follows:

- + The design and construction of handrails shall comply with Clause 12 of AS 1428.1 – 2009.
- + Handrails shall be installed on both sides of the stairs.
- + Handrails shall have no vertical sections and shall follow the angle of the stairway nosings.
- + Where a handrail terminates at the bottom of a flight of stairs, the handrail shall extend at least one tread depth parallel to the line of nosings plus minimum of 300 mm horizontally from the last riser.
- + The handrail shall extend a minimum of 300 mm horizontally past the nosing on the top riser.
- + Where the handrail is continuous, the 300 mm extension is not required in the inner handrail at intermediate landings.
- + The dimensions indicating the heights of handrails shall be taken vertically from the nosing of the tread to the top of the handrail or from the landing to the top of the handrail.

Compliance Readily Achievable:
Details to be developed and provided at Design Development stage.

+ Clause	+ Reference	+ Comment
----------	-------------	-----------

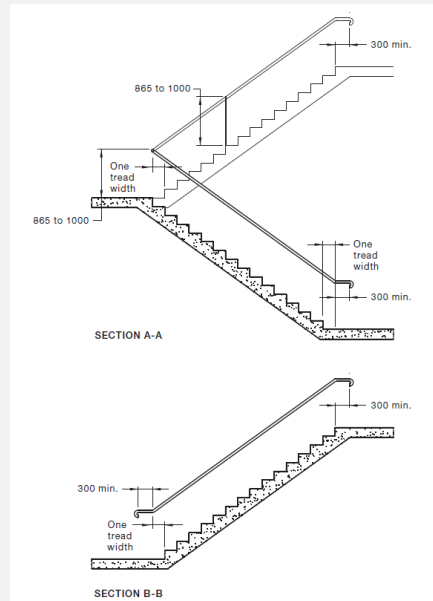
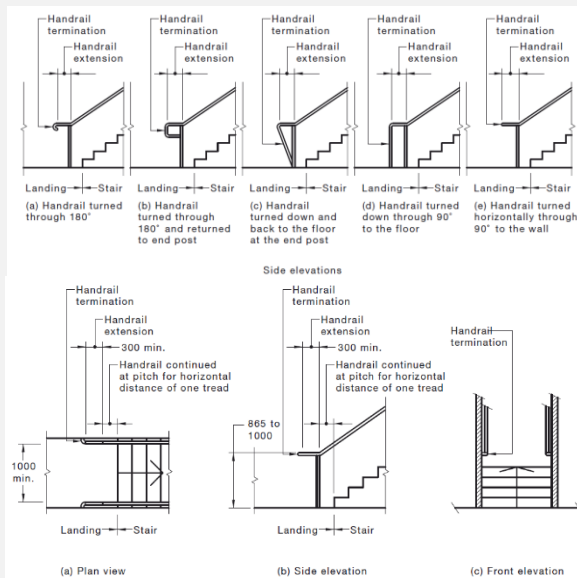

AS1428.1
Cl. 12
Handrails

The design and construction of handrails shall comply with the following:

- + The cross-section of handrails shall be circular or elliptical, between 30-50mm dia. for a width of not less than 270° around the uppermost surface.
- + Exposed edges shall have a radius of not less than 5mm.
- + The top of handrails shall be between 865-1000mm above the nosing line of a stairway, or the plane of finished floor otherwise.
- + The height of the top of the handrail shall be consistent through any stair, ramp, and landing.
- + Handrails shall be securely fixed and rigid, and their ends shall be turned through a total of 180°, or to the ground, or returned fully to end post or wall face.

The clearance between a handrail and an adjacent wall surface or other obstruction shall be not less than 50mm.

Compliance Readily Achievable:

Details to be developed and provided at Design Development stage.

AS1428.1
Cl. 13.1
Luminance Contrast

All doorways shall have a minimum luminance contrast of 30% provided between—

- + door leaf and door jamb;
- + door leaf and adjacent wall;
- + architrave and wall;
- + door leaf and architrave; or
- + door jamb and adjacent wall.

The minimum width of the area of luminance contrast shall be 50 mm.

Compliance Readily Achievable:

Details to be developed and provided at Design Development stage.

Note: Requirement also applies to glazed doors.

+ Clause **+ Reference** **+ Comment**

AS1428.1
Cl. 13.2 /
13.3
Doorways

The minimum width of an accessible doorway must have a *clear opening* width of not less than 850mm in accordance with AS1428.1. Where double doors are provided, at least one leaf must have a clear unobstructed width of 850mm.

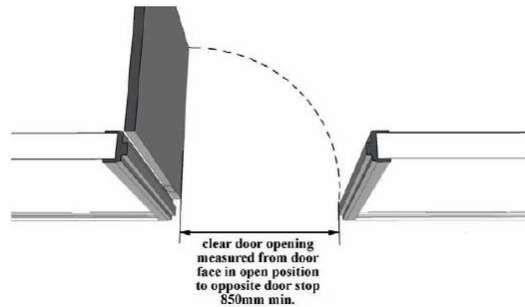

Clear Unobstructed Width of Doorway

Circulation space is required to all doorways throughout the building that are required to be accessible in accordance with Section 13 of AS 1428.1 – 2009 (see diagrams below). Circulation space is not required to be provided to rooms where access for a person with a disability is not required i.e. dirty utility / clean utility rooms, plant rooms, comms rooms etc. See below required doorway circulation space for swinging and sliding doors.

Further Information Required:

Refer to the markups below detailing door circulation non-compliances. These issues will need to be addressed as the design develops.

Performance Solution

The cot room in playroom 4 of the childcare centre does not achieve doorway circulation. Either provide or we can support as a performance solution.

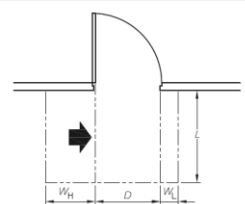

Dimension D	Dimension L	Dimension W _H	Dimension W _L
850	1220	560	340
900	1185	510	340
950	1160	460	340
1000	1140	410	340

(a) Hinge-side approach, door opens away from user

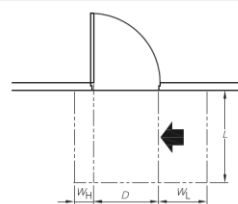

Dimension D	Dimension L	Dimension W _H	Dimension W _L
850	1240	240	660
900	1210	190	660
950	1175	140	660
1000	1155	90	660

(b) Latch-side approach, door opens away from user

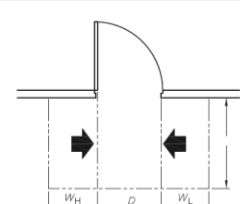

Dimension D	Dimension L	Dimension W _H	Dimension W _L
850	1240	560	660
900	1210	510	660
950	1175	460	660
1000	1155	410	660

(c) Either side approach, door opens away from user

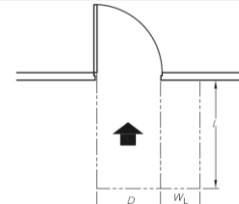

Dimension D	Dimension L	Dimension W _H	Dimension W _L
850	1450	0	510
900	1450	0	510
950	1450	0	510
1000	1450	0	510

(d) Front approach, door opens away from user

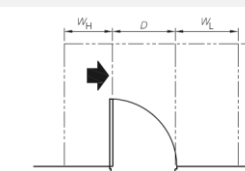

Dimension D	Dimension L	Dimension W _H	Dimension W _L
850	1670	660	900
900	1670	610	900
950	1670	560	900
1000	1670	510	900

(e) Hinge-side approach, door opens towards user

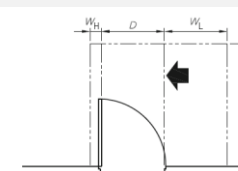

Dimension D	Dimension L	Dimension W _H	Dimension W _L
850	1670	110	900
900	1670	110	900
950	1670	110	900
1000	1670	110	900

(f) Latch-side approach, door opens towards user

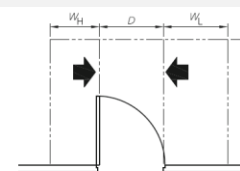

Dimension D	Dimension L	Dimension W _H	Dimension W _L
850	1670	660	900
900	1670	610	900
950	1670	560	900
1000	1670	510	900

(g) Either side approach, door opens towards user

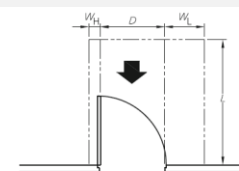

Dimension D	Dimension L	Dimension W _H	Dimension W _L
850	1450	110	530
900	1450	110	530
950	1450	110	530
1000	1450	110	530

(h) Front approach, door opens towards user

+ Clause **+ Reference** **+ Comment**

Dimension	Dimension	Dimension	Dimension
D	L	W _H	W _L
850	1280	660	395
900	1280	610	395
950	1280	560	395
1000	1280	510	395

(a) Slide-side approach

Dimension	Dimension	Dimension	Dimension
D	L	W _H	W _L
850	1230	185	660
900	1230	180	660
950	1230	180	660
1000	1230	180	660

(b) Latch-side approach

Dimension	Dimension	Dimension	Dimension
D	L	W _H	W _L
850	1280	660	660
900	1280	610	660
950	1280	560	660
1000	1280	510	660

(c) Either side approach

Dimension	Dimension	Dimension	Dimension
D	L	W _H	W _L
850	1450	0	530
900	1450	0	530
950	1450	0	530
1000	1450	0	530

(d) Front approach

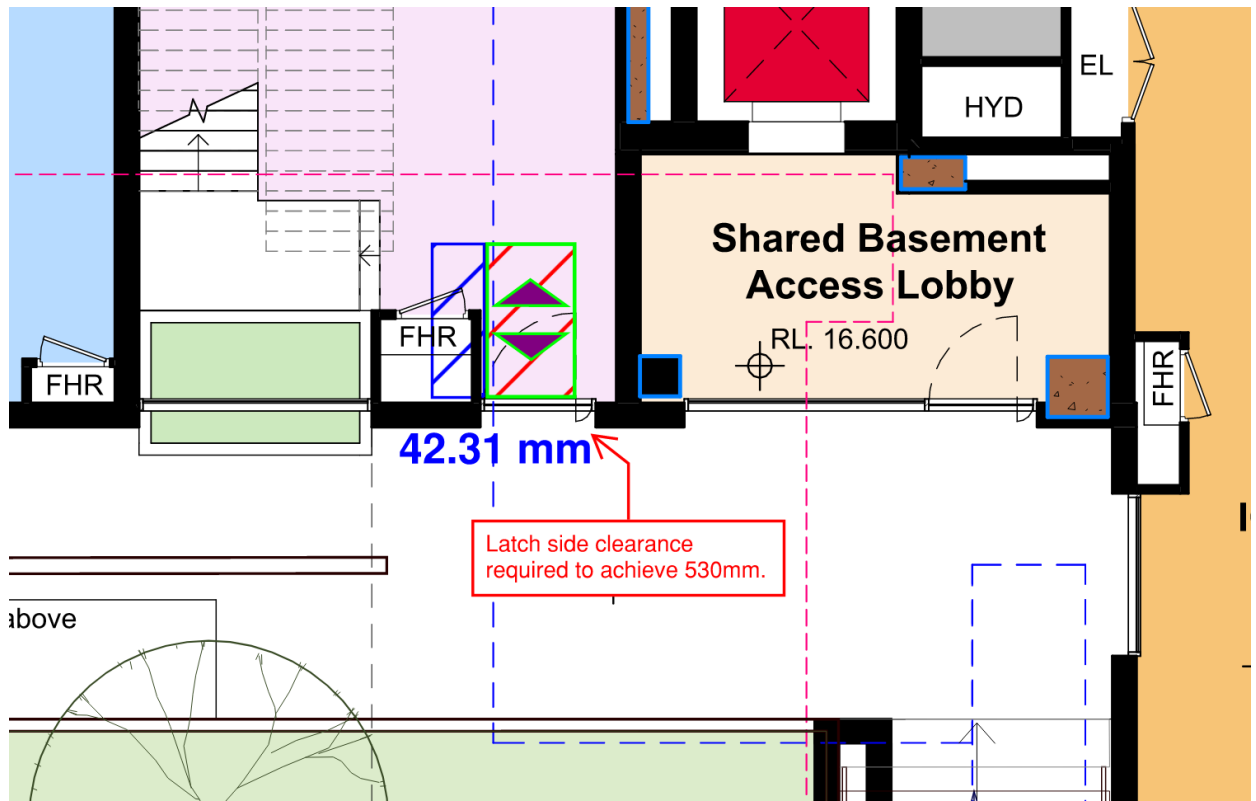

Figure 1: Non-Compliant Doorway Circulation Space at Ground Floor Childcare Lobby

+ Clause	+ Reference	+ Comment
----------	-------------	-----------

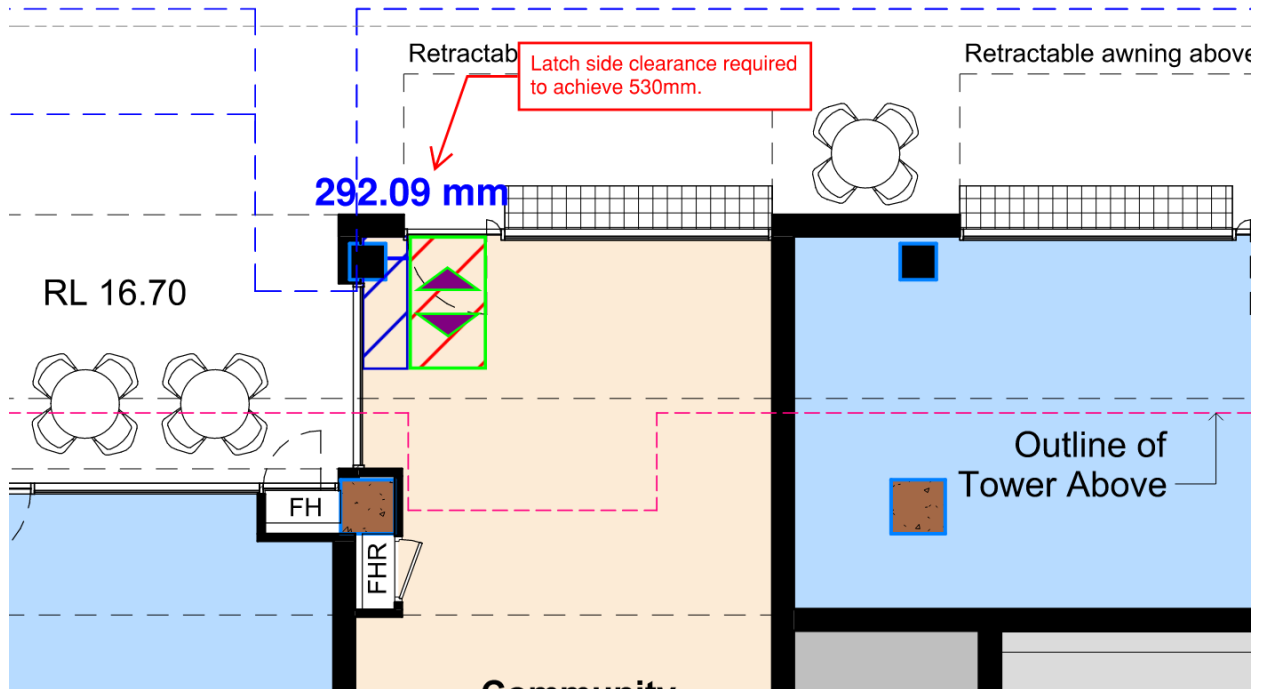

Figure 2: Non-Compliant Doorway Circulation Space at Ground Floor Community Room

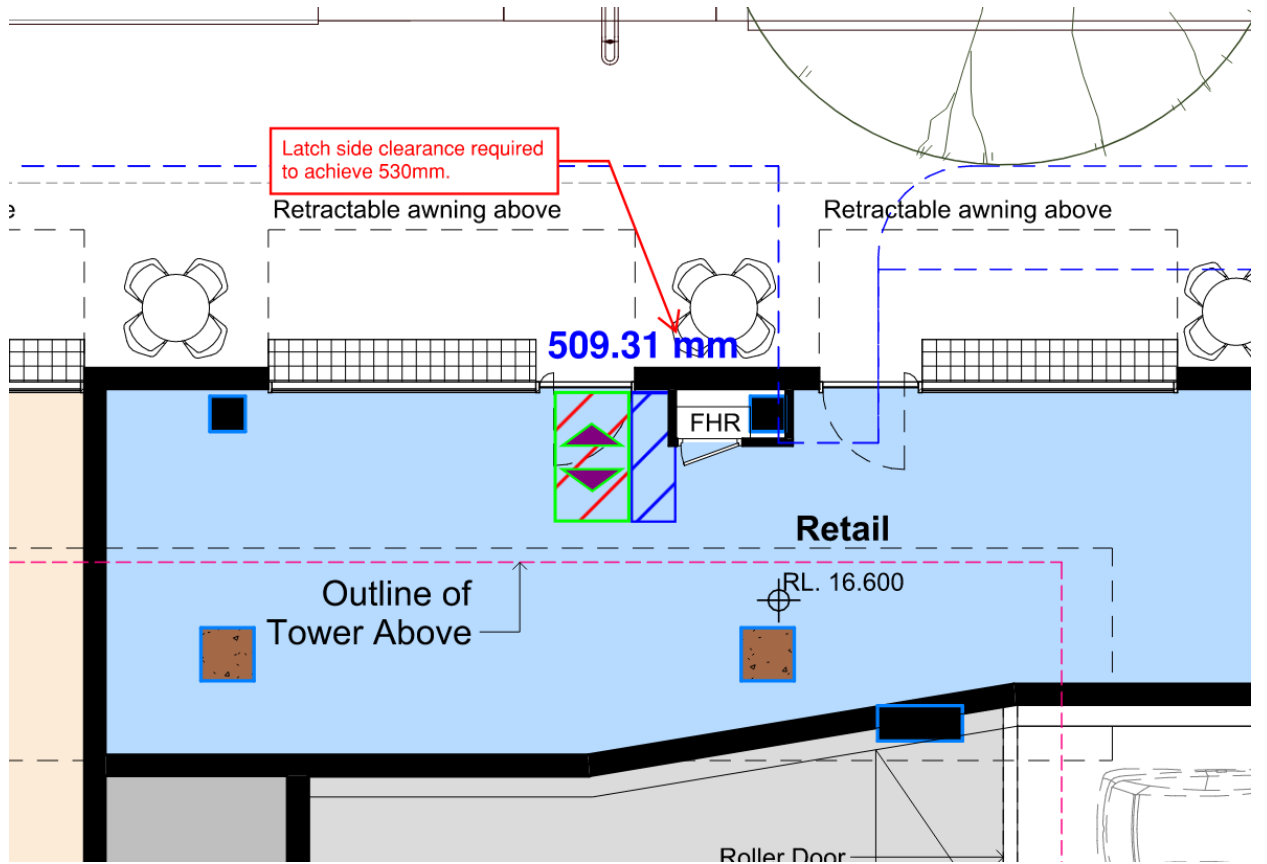

Figure 3: Non-Compliant Doorway Circulation Space at Ground Floor Eastern Retail

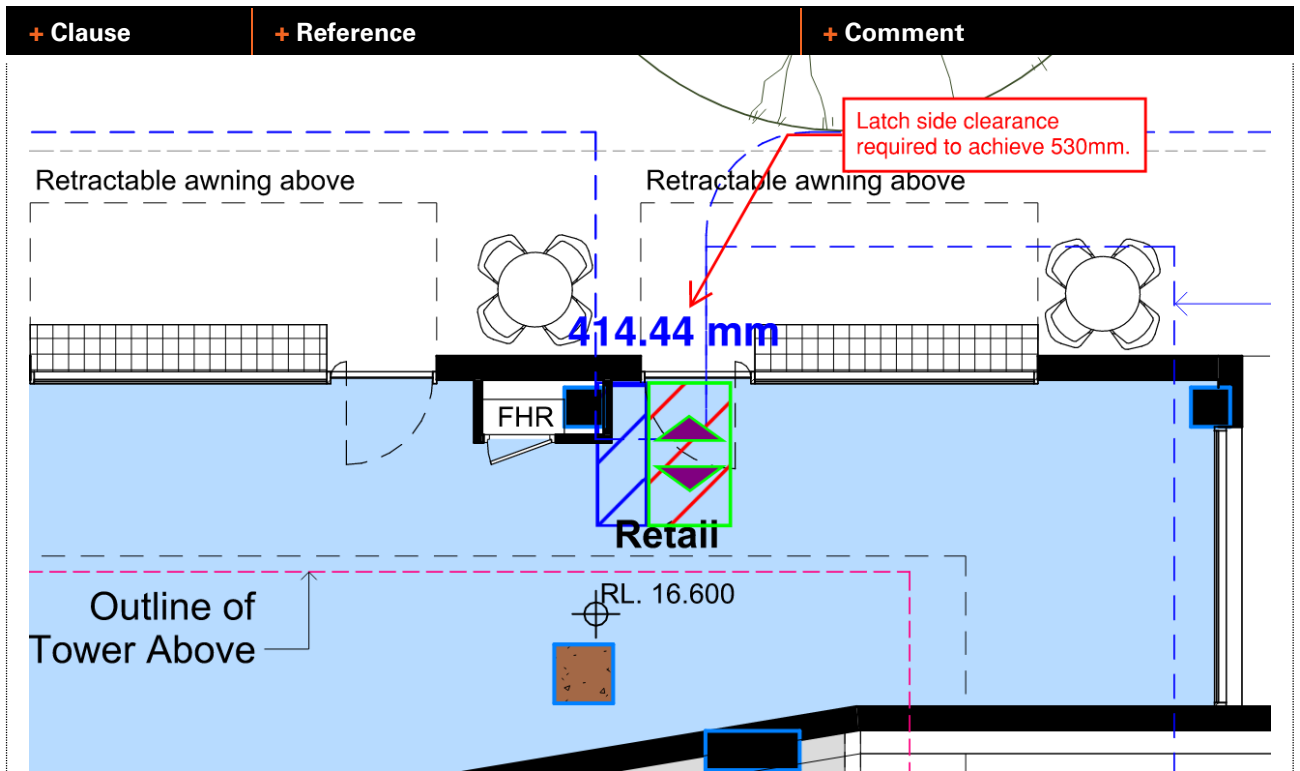

Figure 4: Non-Compliant Doorway Circulation Space at Ground Floor Eastern Retail

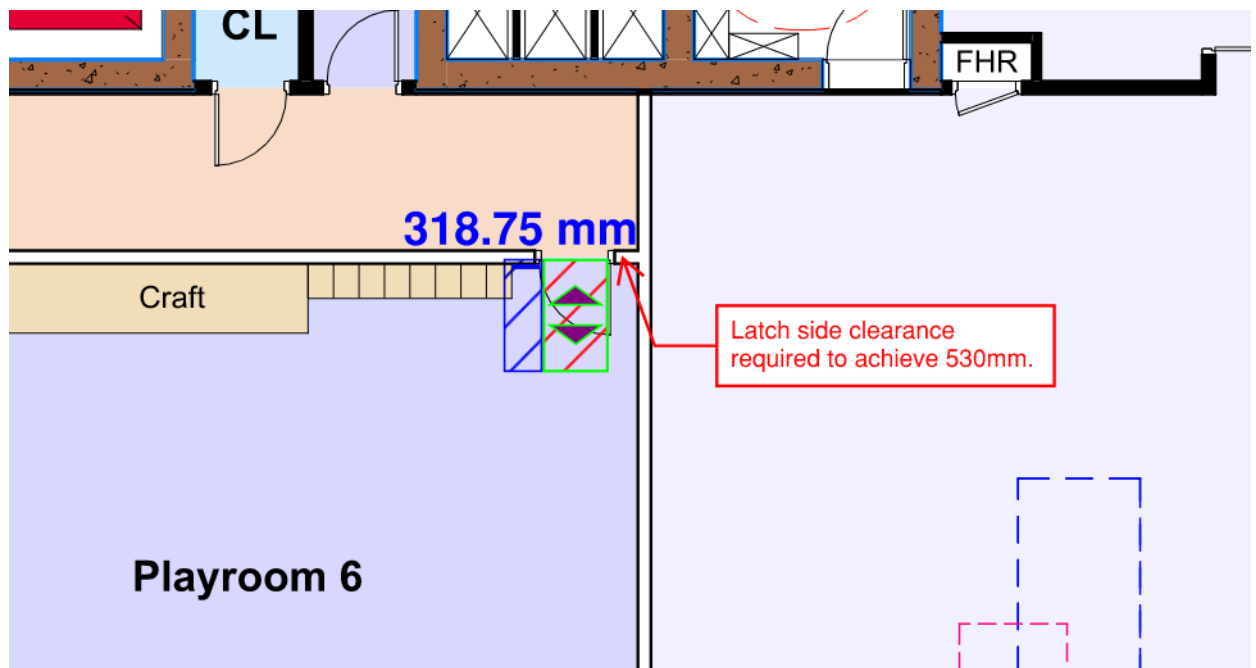

Figure 5: Non-Compliant Doorway Circulation Space at Level 2 Playroom 6

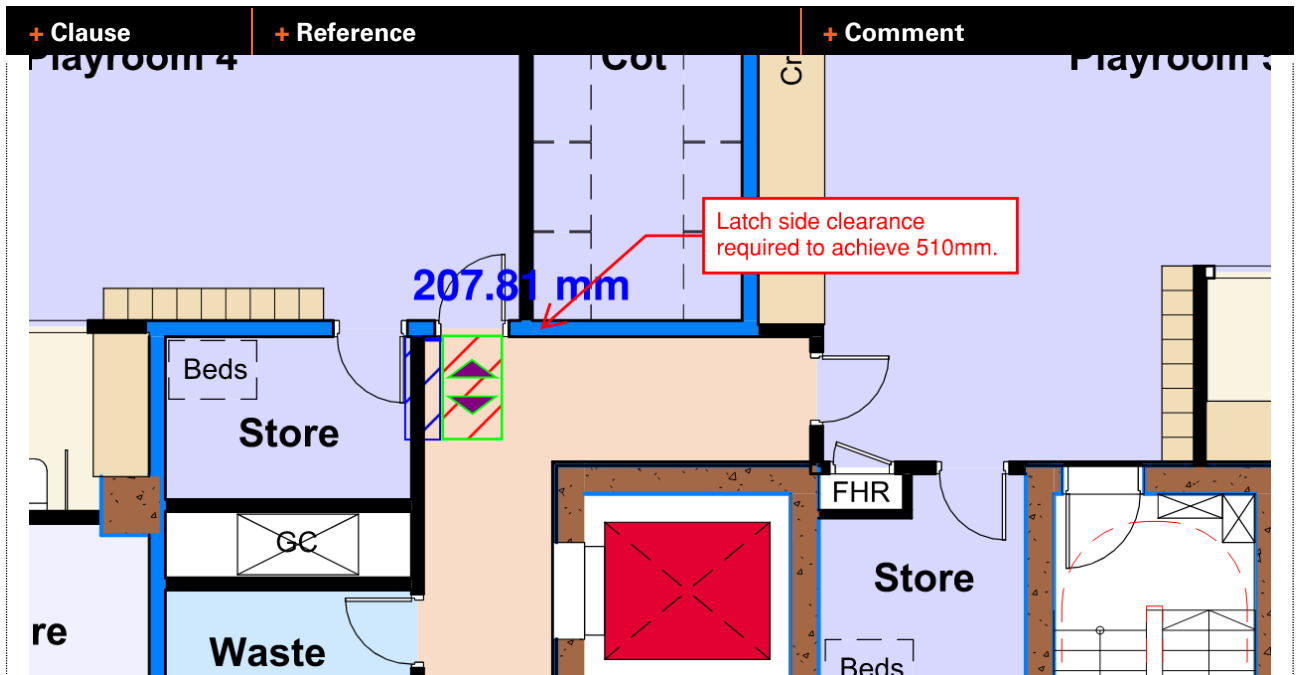
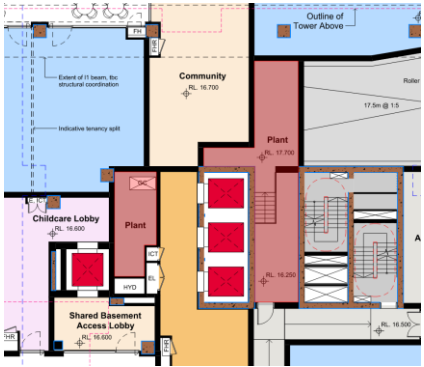
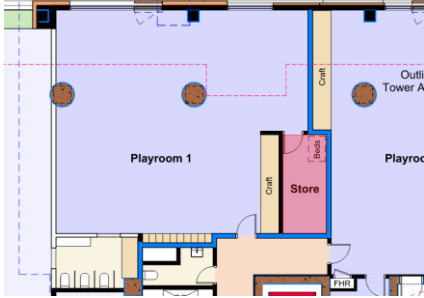
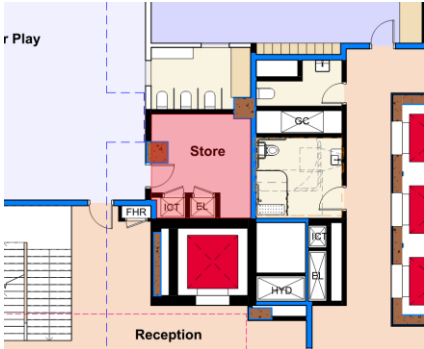
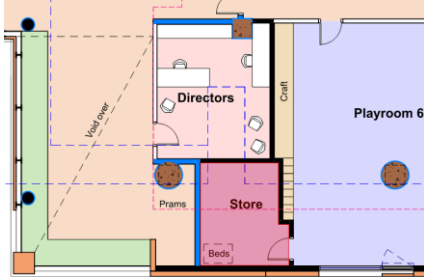

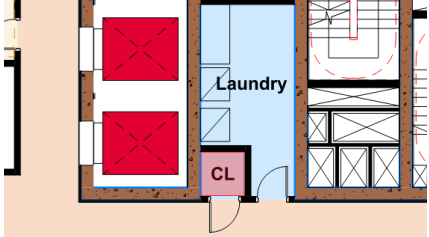
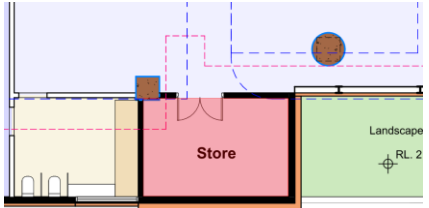

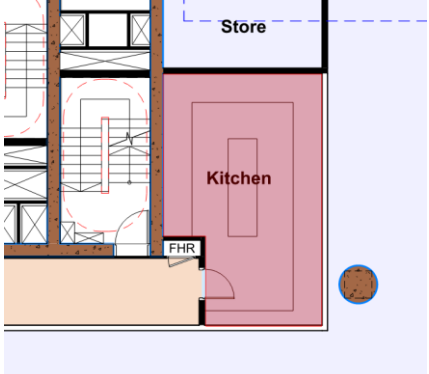
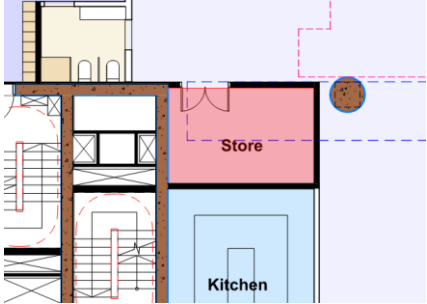
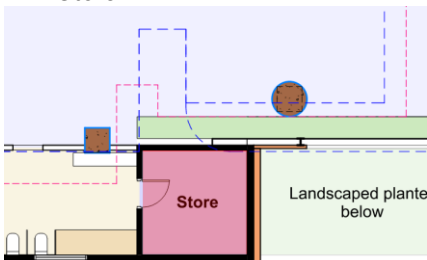





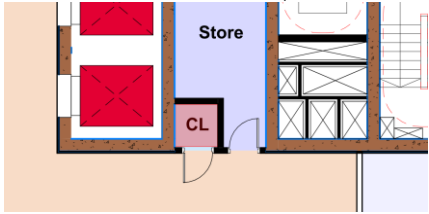

Figure 6: Non-Compliant Doorway Circulation Space at Level 2 Playroom 4 Entry



<p>AS1428.1 Cl. 13.4 Successive Doorways in Passages</p>	<p>The distance between doorways in vestibules, air locks and other similarly enclosed spaces shall be not less than 1450 mm. Where the doors encroach into space, the distance shall be not less than 1450 mm plus the door leaf width.</p> <p>(a) Continuous accessible path of travel</p> <p>DIMENSIONS IN MILLIMETRES</p> <p>FIGURE 34 (in part) DISTANCE BETWEEN SUCCESSIVE DOORWAYS IN VESTIBULES AND AIR LOCKS</p>	<p>We note there are no successive doorways along accessible paths of travel in the design.</p>
<p>AS1428.1 Cl.13.5 Door Controls</p>	<p>Door handles and hardware to rooms required to be accessible must comply with the requirements of Clause 13.5 of AS 1428.1 – 2009.</p>	<p>Compliance Readily Achievable: Details to be developed and provided at Design Development stage.</p>
<p>AS1428.1 Cl.14.1 Switches and GPO's</p>	<p>All switches and controls shall be positioned at a height of 900-1000mm above the FFL and be no closer than 500mm to any corner</p>	<p>Compliance Readily Achievable: Details to be developed and provided at Design Development stage.</p>
<p>AS1428.1 Cl.14.2 Switches</p>	<p>Accessible SOU's and accessible WC's are required to be provided with 30mm x 30mm toggle switches</p> <p>Where push button switches are located associated with the security system of the entry doors, then the push button will need to be the mushroom type.</p>	<p>Compliance Readily Achievable: Details to be developed and provided at Design Development stage.</p>

+ Clause	+ Reference	+ Comment
<p>D4D5 (Previously D3.4) Exemptions</p>	<p>The following areas, and any path of travel providing access <u>only</u> to these areas, are not required to be accessible:</p> <ul style="list-style-type: none"> + An area deemed inappropriate to access due to the areas particular use + An area that would pose a health or safety risk for people with a disability. 	<p>Compliance Readily Achievable</p> <p>Confirmation to be provided of any D4D5 exempt rooms.</p> <p>The following areas may be subject to a D4D5 Exemption:</p> <ul style="list-style-type: none"> + Ground Floor Plant:  + Level 1 Playroom 1 Store.  + Level 1 Northern Outdoor Play Store.  + Level 1 Playroom 6 Store.  + Level 1 Laundry.



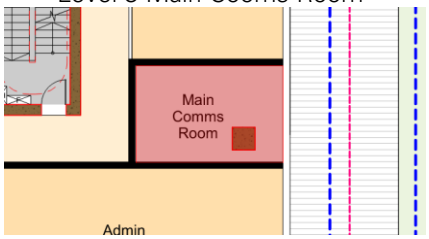

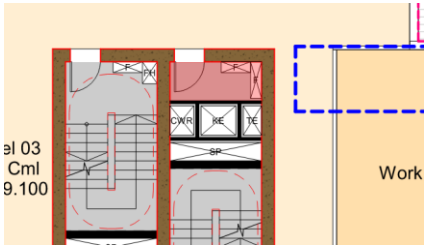
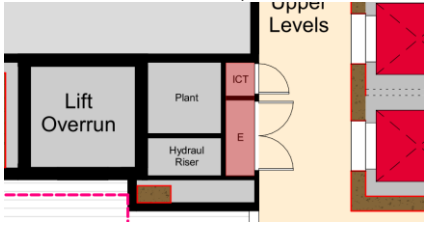
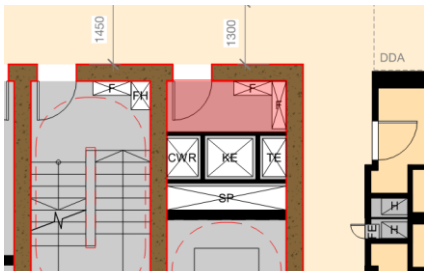
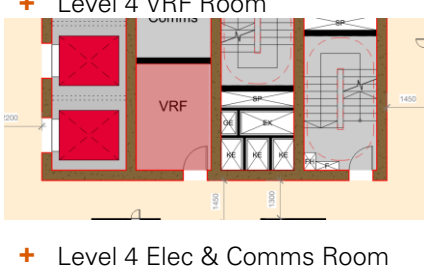

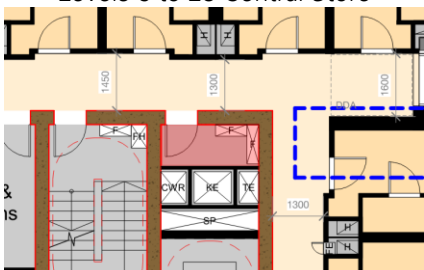
+ Clause	+ Reference	+ Comment
		 <p data-bbox="992 555 1358 589">+ Level 1 Cleaners Cupboard.</p>  <p data-bbox="992 913 1406 976">+ Level 1 western Outdoor Play Store.</p>  <p data-bbox="992 1211 1342 1245">+ Level 1 Playroom 2 Store.</p>  <p data-bbox="992 1621 1230 1655">+ Level 1 Kitchen.</p> 

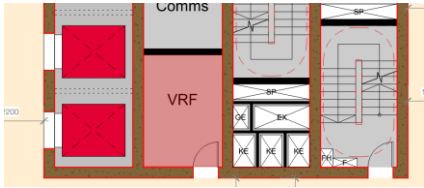
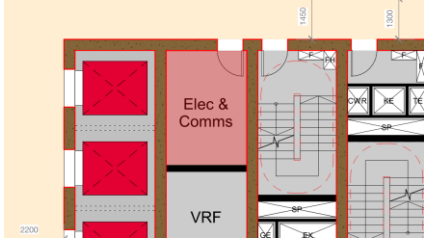
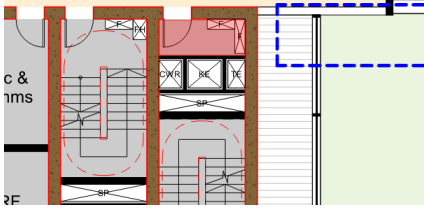
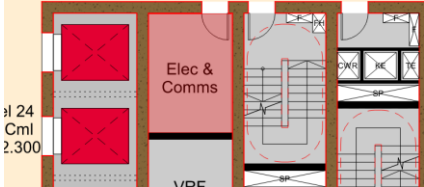
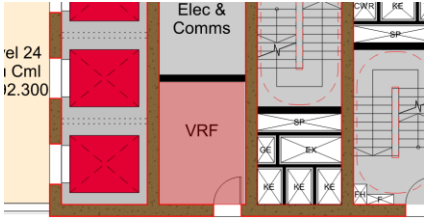
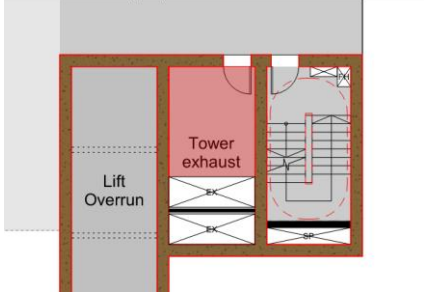
+ Clause	+ Reference	+ Comment
		<p>+ Level 1 Eastern Outdoor Play Store.</p>  <p>+ Level 2 Western Outdoor Play Store.</p>  <p>+ Level 2 Northern Outdoor Play Store.</p>  <p>+ Level 2 Playroom 4 Store.</p>  <p>+ Level 2 Southern Outdoor Play Store.</p>

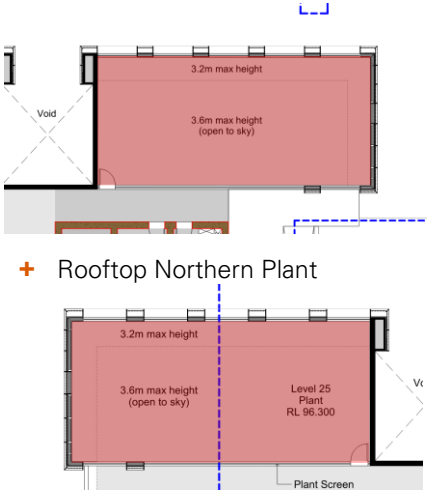
+ Clause	+ Reference	+ Comment
		 <p data-bbox="992 595 1286 629">+ Level 2 Waste Chute</p>  <p data-bbox="992 904 1334 938">+ Level 2 Playroom 4 Store</p>  <p data-bbox="992 1167 1353 1200">+ Level 2 Cleaners Cupboard</p>  <p data-bbox="992 1429 1286 1462">+ Level 2 Central Store</p>  <p data-bbox="992 1691 1358 1724">+ Level 3 Main Comms Room</p>  <p data-bbox="992 1977 1286 2011">+ Level 3 Central Store</p>

+ Clause	+ Reference	+ Comment
		 <p data-bbox="992 385 1040 452">el 03 Cml 9.100</p> <p data-bbox="1369 407 1417 430">Work</p> <p data-bbox="992 519 1311 542">+ Level 3 Plant Cupboard</p>  <p data-bbox="992 631 1072 698">Lift Overrun</p> <p data-bbox="1152 631 1200 654">Plant</p> <p data-bbox="1152 676 1248 698">Hydraul Riser</p> <p data-bbox="1200 609 1232 631">ICT</p> <p data-bbox="1200 676 1216 698">E</p> <p data-bbox="1248 542 1311 564">Upper Levels</p> <p data-bbox="992 788 1279 810">+ Level 4 Central Store</p>  <p data-bbox="992 922 1040 945">1450</p> <p data-bbox="1200 810 1248 833">1300</p> <p data-bbox="992 1102 1248 1124">+ Level 4 VRF Room</p>  <p data-bbox="992 1214 1040 1236">1450</p> <p data-bbox="992 1258 1040 1281">1300</p> <p data-bbox="992 1370 1375 1393">+ Level 4 Elec & Comms Room</p>  <p data-bbox="992 1505 1040 1527">1450</p> <p data-bbox="1200 1393 1248 1415">1300</p> <p data-bbox="1359 1393 1407 1415">1600</p> <p data-bbox="992 1639 1359 1662">+ Levels 5 to 23 Central Store</p>  <p data-bbox="992 1774 1040 1796">1450</p> <p data-bbox="1200 1662 1248 1684">1300</p> <p data-bbox="992 1953 1327 1975">+ Levels 5 to 23 VRF Room</p>

+ Clause	+ Reference	+ Comment
		 <p data-bbox="1002 459 1407 526">+ Levels 5 to 23 Elec & Comms Room</p>  <p data-bbox="1002 788 1300 817">+ Level 24 Central Store</p>  <p data-bbox="1002 1093 1396 1122">+ Level 24 Elec & Comms Room</p>  <p data-bbox="1002 1355 1396 1384">+ Level 24 Elec & Comms Room</p>  <p data-bbox="1002 1624 1316 1691">+ Rooftop Tower Exhaust</p>  <p data-bbox="1002 2004 1316 2033">+ Rooftop Southern Plant</p>

+ Clause	+ Reference	+ Comment		
		 <p>+ Rooftop Northern Plant</p> <p>A letter confirming which areas are subject to an accessibility exemption is required to be provided during the Construction Certificate stage.</p>		
<p>D4D7 (Previously D3.6) Signage</p>	<p>In a building required to be accessible, braille and tactile signage must be provided to all:</p> <ul style="list-style-type: none"> + Required accessible sanitary facilities + Spaces with hearing augmentation + Ambulant sanitary facilities + Non-accessible pedestrian entrances + Each door required to be provided with an exit sign <p>Braille and tactile signage is to comply with sub-clause (a) and Specification 15.</p>	<p>Compliance Readily Achievable:</p> <p>Details to be developed and provided at Design Development stage.</p>		
<p>AS1428.1 Cl.8.1 Forms of Signage</p>	<p>The below signs are examples of required sanitary facility signage.</p> <p>The signs shall be positioned so that the raised braille is between 1200-1600mm above FFL.</p>			
 <p>Unisex Toilets LH UNISEX TOILETS LH</p>	 <p>Female Toilet FEMALE TOILET</p>	 <p>Male Toilet MALE TOILET</p>	 <p>Female Ambulant Toilet FEMALE AMBULANT TOILET</p>	 <p>Male Ambulant Toilet MALE AMBULANT TOILET</p>
<p>Spec 15 Braille and tactile signage</p>	<p><u>Signage Specification:</u> -</p> <p>The signage is to be: -</p> <ol style="list-style-type: none"> (a) Located between 1200-1600mm above FFL (b) Signs with single lines of characters are to have the line of the tactile characters between 1250mm-1350mm above FFL (c) Signage tactile characters must be raised or embossed to a height between 1mm-1.5mm 			

+ Clause	+ Reference	+ Comment
	<ul style="list-style-type: none"> - 1000-2000 people – 35 receivers plus 1 receiver for every 50 people in excess of 1000; and - >2000 people – 55 receivers plus 1 receiver for every 100 people in excess of 2000. <p>Any screen or scoreboard capable of displaying public announcements must be capable of supplementing any public address system.</p> <p>The below symbol shall be provided on a sign in ultramarine blue in accordance with clause 5.1 of AS 1428.5-2010</p> 	
<p>D4D9 (Previously D3.8) Tactile Indicators</p>	<p>Tactile ground surface indicators must be provided to:</p> <ul style="list-style-type: none"> + A stairway, other than a fire-isolated stairway; and + An escalator or passenger conveyor; and + A ramp other than a fire-isolated ramp; and + In the absence of a suitable barrier- <ul style="list-style-type: none"> - An overhead obstruction <2m above floor level; and - An accessway meeting a vehicular way adjacent to any pedestrian entrance to a building including a pedestrian entrance serving an area referred to in D4D5, if there is no kerb or kerb ramp at that point. <p>Tactile indicators are required to be designed in accordance with AS 1428.4.1-2009.</p>	<p>Compliance Readily Achievable: Details to be developed and provided at Design Development stage.</p>

+ Clause	+ Reference	+ Comment
----------	-------------	-----------

AS1428.4.1
Cl.2.2.3
Placement

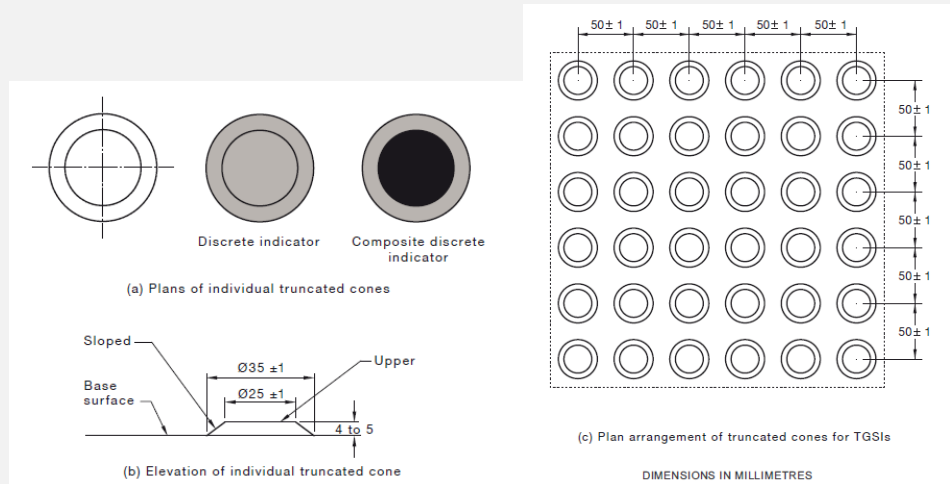

AS1428.4.1
Cl.2.4
Stairways

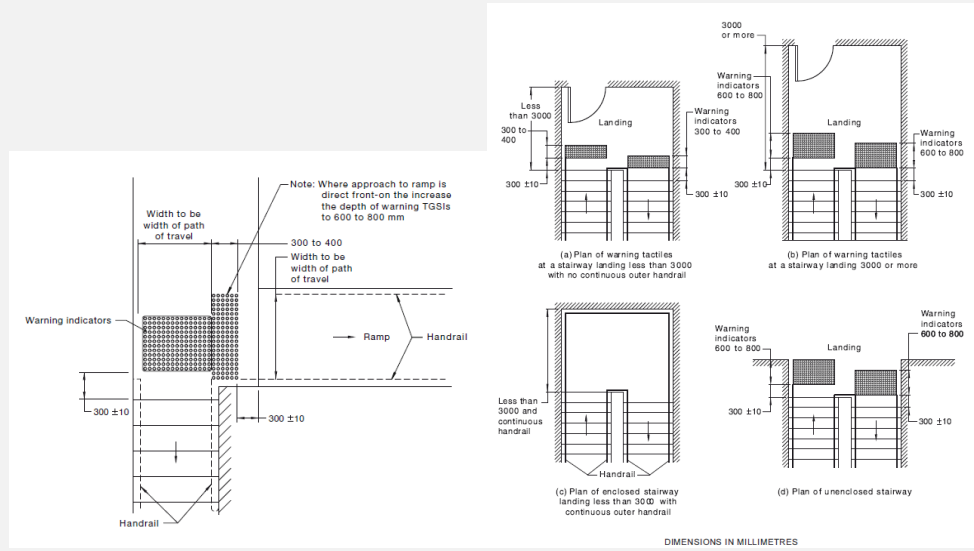

AS1428.4.1
C3
Kerb Ramps

- TGSI's are not required on kerb ramps if –
- + the distance between the building line/boundary and the top of the kerb ramp is less than 3 m;
 - + the change in gradient between that of the pedestrian surface at the top of the kerb ramp and the gradient of the kerb ramp surface lies between 1 in 8 to 1 in 8.5; and
 - + the kerb ramp is aligned with the building line and

+ Clause	+ Reference	+ Comment
----------	-------------	-----------

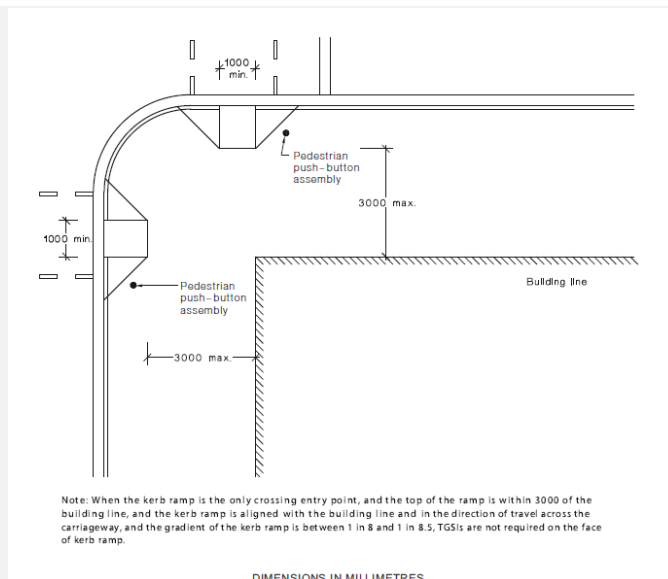

Tactiles are required when a kerb ramp where the gradient is shallower than 1 in 8.5.

<p>D4D12 (Previously D3.11) Ramps</p>	<p>Ramps may be used as part of an accessway where there is a change of level and must comply with the requirements set out in AS1428.1</p>	<p>Further Information Required: Show the location of the allotment boundary. Ramps cannot start closer than 900mm from an allotment boundary.</p>
<p>AS1428.1 Cl 10.1 Walkways, Ramps, and Landings - Generally</p>	<p>Walkways, ramps and landings that are provided on a continuous accessible path of travel shall be as follows:</p> <ul style="list-style-type: none"> + Sharp transitions shall be provided between the planes of landings and ramps. + Landings shall be provided at all changes in direction in accordance with Clause 10.8. + Landing or circulation space shall be provided at every doorway, gate, or similar opening. + For walkways and landings having gradients in the direction of travel shallower than 1 in 33, a camber or crossfall shall be provided for shedding of water and shall be no steeper than 1 in 40, except that bitumen surfaces shall have a camber or crossfall no steeper than 1 in 33. <p><i>NOTE: For requirements for ground surfaces, see Clause 7.</i></p>	<p>Compliance Readily Achievable: Details to be developed and provided at Design Development stage.</p>
<p>AS1428.1 Cl. 10.2 Walkways</p>	<p>The requirements for walkways are as follows:</p> <ul style="list-style-type: none"> + Walkways can have a gradient up to 1:20. Anything steeper is a ramp and requires kerbs or kerb rails plus handrails to both sides. 	<p>Compliance Readily Achievable: Details to be developed and provided at Design Development stage.</p>

+ Clause	+ Reference	+ Comment
----------	-------------	-----------

- + A walkway with a gradient less than 1 in 33 does not require landings but does require a crossfall of maximum 1 in 40 (maximum cross fall of 1 in 33 if the surface is bitumen).
- + Walkways steeper than 1 in 33 do not require a crossfall to the main walkway but do require a crossfall of 1 in 40 to landings

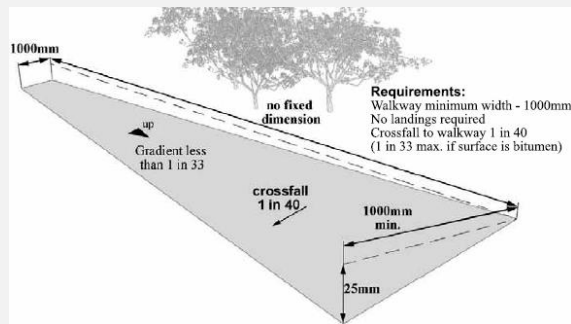

Requirements for a Walkway with a Gradient Less Than 1 in 33

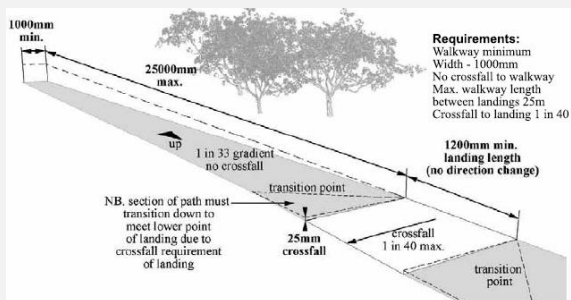

Requirements for a Walkway with a 1 in 33 Gradient

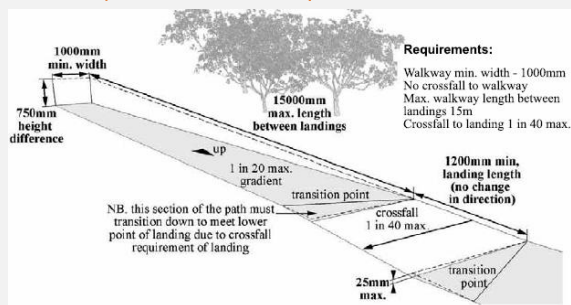

Requirements for a Walkway with a 1 in 20 Gradient

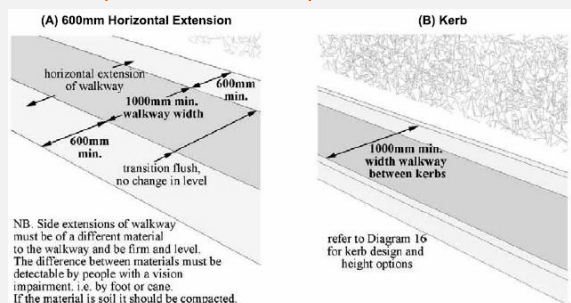

Requirements for Edges of Walkways

AS1428.1 Cl. 10.3	Ramps to comply with the following:	Compliance Readily Achievable:
------------------------------------	-------------------------------------	---------------------------------------

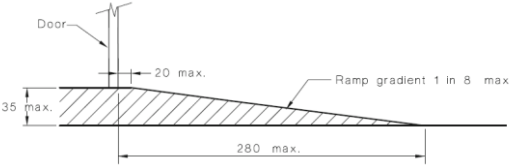
+ Clause	+ Reference	+ Comment
<p>Ramps</p>	<ul style="list-style-type: none"> + Maximum gradient of a ramp exceeding 1900mm shall be 1 in 14. + The gradient of a ramp shall be constant throughout its length. + Ramps shall be provided with landings: <ul style="list-style-type: none"> - For ramp gradients of 1 in 14, at intervals not greater than 9m. - For ramp gradients steeper than 1 in 20, at intervals not greater than 15m. - For ramp gradients between 1 in 14 and steeper than 1 in 20, at interpolated intervals. + Handrails must be provided on either side complying with Clause 12. + TGSIs shall be installed in accordance with AS 1428.4.1. + Ramps shall be set-back at internal corridors so that handrail extensions do not protrude in to paths of travel. + Ramps and intermediate landings shall have kerbs or kerb rails on either side. 	<p>Details to be developed and provided at Design Development stage.</p>
<p>AS1428.1 Cl. 10.5 Threshold Ramps</p>	<p>Threshold ramps at doorways on a continuous path of travel shall have—</p> <ul style="list-style-type: none"> + a maximum rise of 35 mm; + a maximum length of 280 mm; + a maximum gradient of 1:8; and + be located within 20 mm of the door leaf which it serves. 	<p>Compliance Readily Achievable: Details to be developed and provided at Design Development stage.</p>
<p>AS1428.1 Cl. 10.6 Step Ramps</p>	<p>Step ramps shall have—</p> <ul style="list-style-type: none"> + a maximum rise of 190 mm; + a length not greater than 1900 mm; and + a gradient not steeper than 1 in 10. <p>The edges of step ramp shall have a 45° splay where there is pedestrian cross traffic. Otherwise, it shall be protected by a suitable barrier, such as—</p> <ul style="list-style-type: none"> + a wall or suitable barrier with a minimum height of 450 mm; or + where an open balustrade is provided a kerb or kerb rail shall be provided. 	<p>Compliance Readily Achievable: Details to be developed and provided at Design Development stage.</p>

+ Clause	+ Reference	+ Comment
----------	-------------	-----------

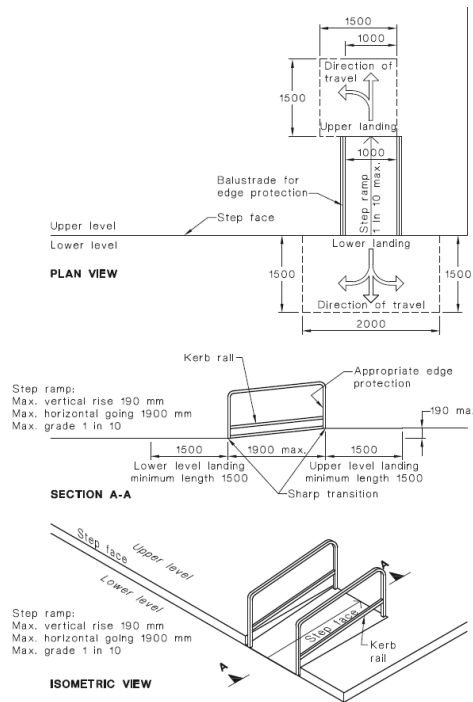

AS1428.1
Cl. 10.7
Kerb
Ramps

Kerb ramps shall have

- + a maximum rise of 190 mm; and
- + a length not greater than 1520 mm; and
- + a gradient not steeper than 1 in 8, located within or attached to a kerb; and

be aligned in the direction of travel as shown below.

We note no kerb ramps are noted in the design.

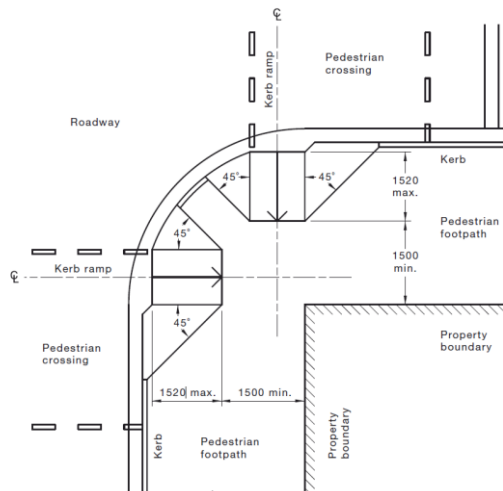

Refer to Clause 10.7 of AS 1428.1 - 2009 for the full requirements for Kerb Ramps.

AS1428.1
Cl. 10.8
Landings

Walkways and ramps
The length of landings at walkways (up to a gradient of 1 in 33) and ramps shall comply with one of the following:

Compliance Readily Achievable:
Details to be developed and provided at Design Development stage.

+ Clause	+ Reference	+ Comment
	<ul style="list-style-type: none"> + Where there is no change in direction, the length shall be not less than 1200 mm, as shown in Figure 25(A). + Where there is a change of direction not exceeding 90°, the landing shall be not less than 1500 mm. The internal corner shall be truncated for a minimum of 500 mm in both directions, as shown in Figure 25(B). + For a 180° turn, the landing shall be as shown in Figure 25(C). <p><u>Step ramps</u></p> <ul style="list-style-type: none"> + The length of landings at step ramps shall be not less than 1200 mm in the direction of travel, as shown in Figures 22(A) and 22(B). + Where a change in direction is required, the length of step ramp landings shall be a minimum of 1500 mm, as shown in Figure 22(A). + Where doorways are at landings, the dimensions of the landings shall be in accordance with the requirements of Clause 13.3 for circulation spaces at doorways shown in Figure 25(D). <p><u>Kerb ramps</u></p> <p>The length of landings at kerb ramps shall be not less than 1200 mm in the direction of travel.</p> <p>Where a 'T' junction occurs, the kerb ramp landing shall be a minimum of 1500 × 2000 mm, as shown in Figure 24(B).</p> <p>Where a single change in direction is required, the ramp landings shall be a minimum of 1500 mm × 1500 mm.</p> <p>See Below for Figures</p>	

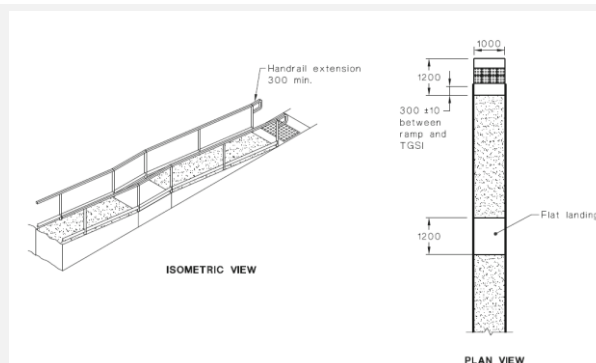

Figure 25A

+ Clause	+ Reference	+ Comment
----------	-------------	-----------

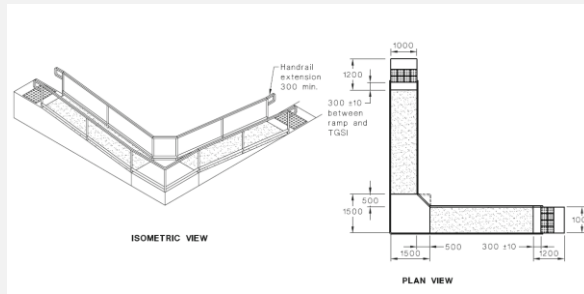

Figure 25B

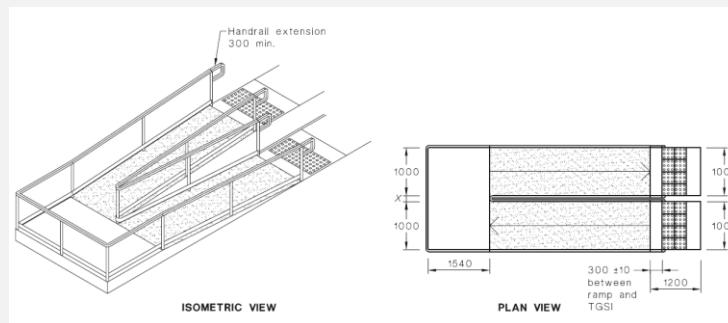

Figure 25C

D4D13
(Previously D3.12)
Glazing on an Accessway

AS1428.1
Cl. 6.6
Visual Indicators on Glazing

Where there is no chair rail, handrail or transom, all frameless or fully glazed doors, sidelights, including any glazing capable of being mistaken for a doorway or opening, shall be clearly marked for their full width with a solid and non-transparent contrasting line.

The contrasting line shall be not less than 75 mm wide and shall extend across the full width of the glazing panel. The lower edge of the contrasting line shall be located between 900 mm and 1000 mm above the plane of the finished floor level.

Any contrasting line on the glazing shall provide a minimum of 30% luminance contrast when viewed against the floor surface or surfaces within 2 m of the glazing on the opposite side.

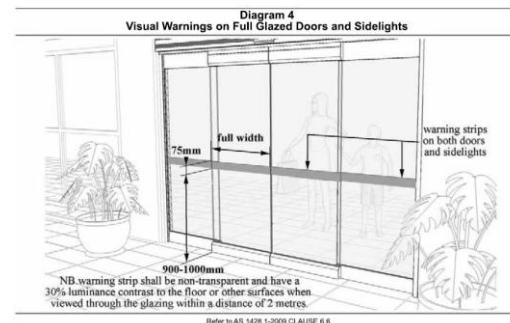

Compliance Readily Achievable:
Glazing decal details to be provided at Detailed Design Development stage.

Section E	Services and Equipment	
Part E3	Lift installations	

+ Clause	+ Reference	+ Comment
E3D7 (Previously E3.6, Table E3.6a, Table E3.6b) Passenger Lift types and their limitations	In an accessible building, every passenger lift must be one of the types identified in this clause, have accessible features in accordance with Table E3D8 and not rely on a constant pressure device for its operation if the lift car is fully enclosed.	Compliance Readily Achievable: Design statement to be provided at Construction Certificate stage.

Section E Health and Amenity

Part F4 Sanitary and Other Facilities

F4D5 (Previously F2.4) Accessible Sanitary Facilities	Accessible unisex sanitary compartments must be provided, in accordance with F4D6 and unisex showers must be provided in accordance with Table F4D7, in buildings or parts that are required to be accessible.	Compliance Readily Achievable: Details to be developed and provided at Design Development stage. Performance Solution: To allow no accessible sanitary facility to be provided on level 2 of the childcare centre.
---	--	---

+ Unisex Accessible WCs

- + Tap sets will need to be specified with lever or capstan handles in the accessible sanitary facilities.
- + Provision of wall strengthening for grab-rails will need to be provided adjacent to sanitary facilities.

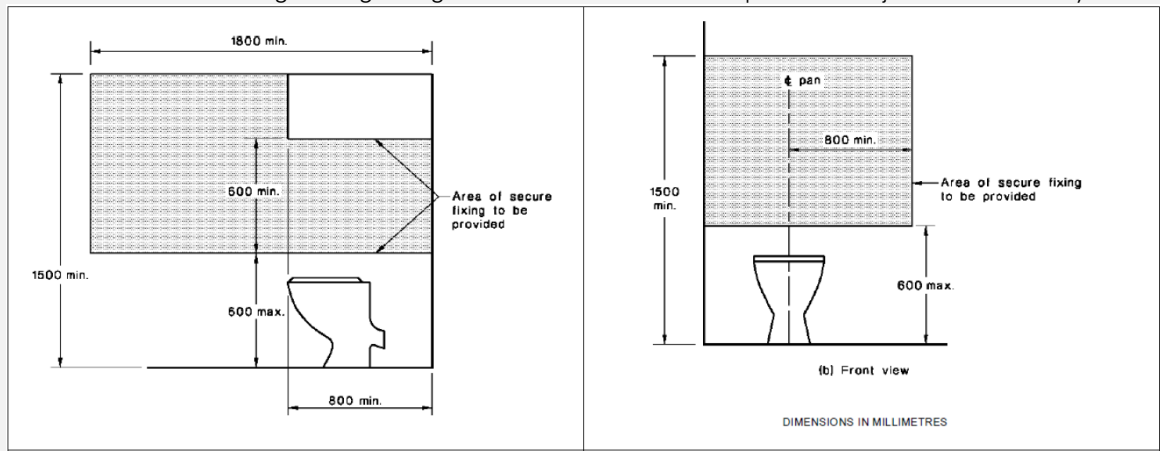

- + The location and installation of washbasins must comply with the requirements of AS 1428.1-2009.

+ Clause	+ Reference	+ Comment
----------	-------------	-----------

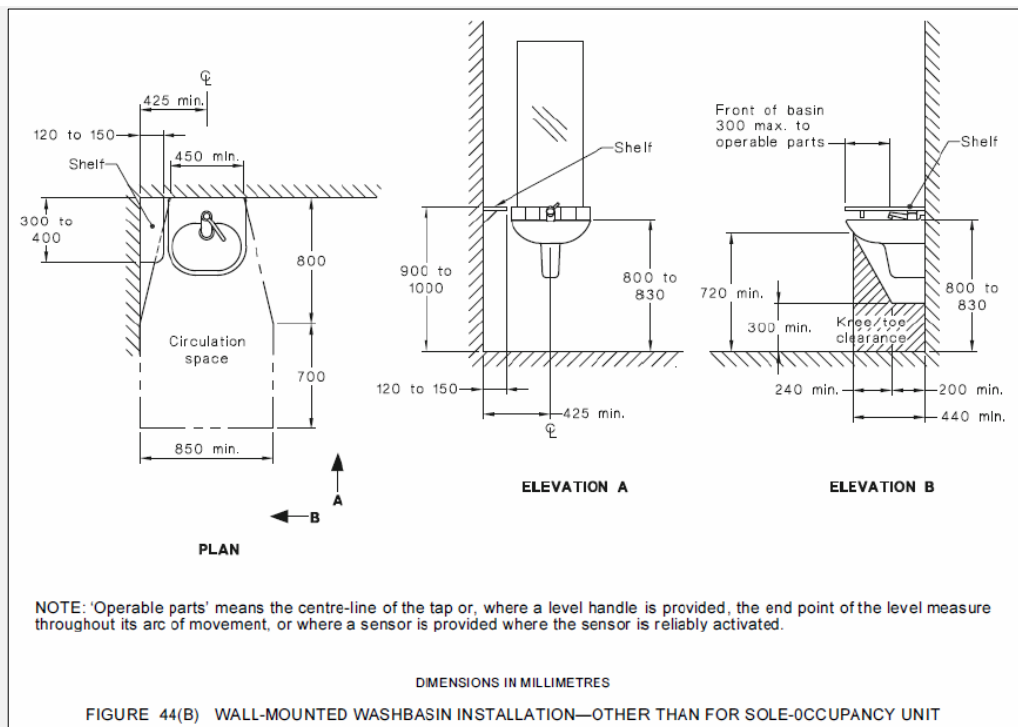

+ Checklist for Accessible WCs	
+ Entry Door	The detailing of the circulation at doorways shall comply with the provisions of Clause 13 of AS1428.1:2009
+ Entry Door	The luminance contrast provisions at the doorway shall comply with the provisions of Clause 13.1 of AS1428.1:2009
+ Force Required to Operate Door	The force required to operate the door if fitted with a door closer is a maximum of 20N. It is assumed that auto-doors will not be installed
+ Door Hardware	The position of door hardware is to be located between 900-1100mm AFFL.
+ WC Pan Circulation	1900x2300mm
+ Hand Basin Circulation	850x1500mm, the basin may encroach a maximum of 100 mm into the circulation space of the adjacent WC pan circulation
+ WC Pan Offset From Side Wall	450/460 mm
+ WC Pan Offset From Rear Wall	800±10 mm
+ WC Pan Backrest	To code requirements
+ WC Pan Toilet Seat	The toilet seat will need to be the full round type, securely fixed in position, be rated 250 KG and have a minimum limits contrast of 30% with the background pan, wall or floor against which it is viewed.
+ WC Pan Grab Rails	Grab rail to be mounted 800 mm above finish floor level, length of grab rail to be 1050 mm from rear wall, install 300mm grab rail to left-hand side of the WC pan. It is assumed that the walls to which the grab rails are fixed will have the required 1100N force rating wall reinforcement required by the standard
+ Hand Basin Mounting Height	Top of hand basin to be 800/830 mm above finish floor level
+ Hand Basin Clearances	The clearances around and under the hand basin need to comply with the provisions of clause 15.3 of AES 1428.1:2009. Specific attention is drawn to the plumbing installation where the required clearances under the hand basin necessitate special consideration of the bottle trap associated with the hand basin

+ Clause	+ Reference	+ Comment
+ Hand Basin Selection		The detailing of the hand basin requires the installation of a shelf unit. It may be possible to specify a hand basin that incorporates a shelf section thereby eliminating an additional component to be installed in the USAT
+ Hand Basin Mirror		The mirror is to be flush mounted on the wall above the sink the bottom of the mirror is to be no more than 900 mm above the finish floor level and the top of the mirror is to be a minimum of 1850 mm above the finish floor level
+ Hand Basin Tap		It is recommended that a lever hand basin tap be installed in lieu of the capstan type
+ Toilet Roll Holder		The position of the toilet roll holder is to be in accordance with code requirements
+ Coat Hooks		Coat hooks are to be installed 1200 to 1350 mm above finish floor level and not closer than 500 mm from an internal corner. The coat hook can be installed on the wall or on the back of the door
+ Soap Dispensers/Hand Towel		These items are to be able to be operated by one hand and shall be installed so that the tap or dispenser is not less than 900 and not more than 1100 mm above the finish floor level.
+ Braille Tactile Signage		The detailing of the Braille Tactile Signage will need to comply with the provision of NCC Clause D4D7 and NCC Specification 15. The location of the Braille Tactile sign is to be mounted on the latch-side wall. The sign is to indicate the handing of the grabrails to the WC Pan. The following is an example of the type of information to be provided in the Braille Tactile Sign.

+ Ambulant WCs

+ Checklist for Ambulant WCs

+ Entry Door	The entry doorway is to achieve a clear width of no less than 750mm.
+ Door Hardware	<ul style="list-style-type: none"> + Shall be provided with an in-use indicator and a bolt or catch. + Where a snip catch is used, the snib-handle shall have a minimum length of 45mm from the centre of the spindle. + In an emergency, the latch mechanism shall be openable from the outside.
+ Internal Dimensions	Width between internal walls is to achieve between 900 – 920mm. A 900x900 clear area must be provided in front of the toilet pan, fixtures (including door swing) cannot encroach on this distance, except for grab rails.

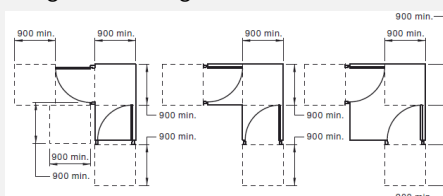

(b) Path of travel to ambulant toilets

DIMENSIONS IN MILLIMETRES

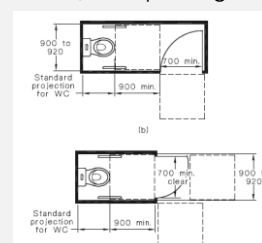

(tbl)

+ Clause	+ Reference	+ Comment
<p>+ Grab Rails</p>	<p>Grab rails are to be located on either side of the toilet pan and must be located between 800 – 810mm above finished floor level.</p> <ul style="list-style-type: none"> + Grab rail length and up-turn to be in accordance with Figure 53(A) of AS 1428.1 – 2009. + Grab rails shall have an outside diameter of 30 – 40mm. + Exposed edges and corners of grab rails shall have a radius of not less than 5mm. + The fastenings and the materials and construction of grab rails shall be able to withstand a force of 1100 N applied at any position. + Clearance between the grab rail and the adjacent wall shall be between 50 – 60mm. 	
<p>+ Toilet Roll Holder</p>	<p>The position of the toilet roll holder is to be in accordance with code requirements</p>	
<p>+ Coat Hook</p>	<p>A coat hook shall be provided within the sanitary compartment at a height between 1350mm to 1500mm from the floor.</p>	
<p>+ Braille Tactile Signage</p>	<p>The detailing of the Braille Tactile Signage will need to comply with the provision of NCC Clause D4D7 and NCC Specification 15. The location of the Braille Tactile sign is to be mounted on the latch-side wall. Signage content is to comply with the requirements of Clause 8 of AS 1428.1 – 2009.</p>	



5.0 Conclusion

This report contains an assessment of the referenced architectural documentation for the proposed construction of Building 2 at Waterloo Metro Quarter Development against the deemed-to-satisfy provisions of the Building Code of Australia 2022 Amendment 2.

Arising from the assessment, key compliance issues have been identified that require further resolution, either by way of fire engineered Performance Solutions or plan amendments prior to the building approval.

Notwithstanding the above, it is considered that the proposed development can readily achieve compliance with the BCA subject to resolution of the matters identified in the Section 3.0 and 4.0 of this report.



Appendices

+ Appendix 1 – Fire Resisting Construction Requirements

TYPE A CONSTRUCTION: FRL OF BUILDING ELEMENTS				
+ Building Element	+ Class of Building - FRL: (in minutes) Structural adequacy/integrity/insulation			
	2, 3 or 4 part	5, 7a or 9	6	7b or 8
EXTERNAL WALL – (Including any column and other building element incorporated within it) or other external building element, where the distance from any fire-source feature to which it is exposed is:				
For loadbearing parts:				
Less than 1.5m	90/90/90	120/120/120	180/180/180	240/240/240
1.5 to less than 3m	90/60/60	120/90/90	180/180/120	240/240/180
3m or more	90/60/30	120/60/30	180/120/90	240/180/90
For non-loadbearing parts:				
less than 1.5m	-/90/90	-/120/120	-/180/180	-/240/240
1.5 to less than 3m	-/60/60	-/90/90	-/180/120	-/240/180
3m or more	-/-/-	-/-/-	-/-/-	-/-/-
EXTERNAL COLUMN - Not incorporated in an external wall				
For loadbearing columns	90/-/-	120/-/-	180/-/-	240/-/-
For non-loadbearing columns	-/-/-	-/-/-	-/-/-	-/-/-
COMMON WALLS and FIRE WALLS	90/90/90	120/120/120	180/180/180	240/240/240
INTERNAL WALLS				
Fire-resisting lift and stair shafts				
Loadbearing	90/90/90	120/120/120	180/120/120	240/120/120s
Non-loadbearing	-/90/90	-/120/120	-/120/120	-/120/120
Bounding public corridors, public lobbies and the like:				
Loadbearing	90/90/90	120/-/-	180/-/-	240/-/-
Non-loadbearing	-/60/60	-/-/-	-/-/-	-/-/-
Between or bounding sole-occupancy units:				
Loadbearing	90/90/90	120/-/-	180/-/-	240/-/-
Non-loadbearing	-/60/60	-/-/-	-/-/-	-/-/-
Ventilating, pipe, garbage, and the like shafts not used for the discharge of hot products of combustion:				
Loadbearing	90/90/90	120/90/90	180/120/120	240/120/120
Non-loadbearing	-/90/90	-/90/90	-/120/120	-/120/120
OTHER LOADBEARING INTERNAL WALLS, INTERNAL BEAMS, TRUSSES, AND:				
COLUMNS	90/-/-	120/-/-	180/-/-	240/-/-

TYPE A CONSTRUCTION: FRL OF BUILDING ELEMENTS				
FLOORS	90/90/90	120/120/120	180/180/180	240/240/240
ROOFS	90/60/30	120/60/30	180/60/30	240/90/60

Notes:

1. Any lightweight construction in a fire wall or an internal wall required to have an FRL is to comply with Specification 11.
2. Where a part of a building required to have an FRL depends upon direct vertical or lateral support from another part to maintain its FRL, that supporting part must typically achieve the same FRL. Where that part is also required to be non-combustible, the supporting part must also be non-combustible.
3. A loadbearing internal wall and a loadbearing fire wall (including those that are part of a loadbearing shaft) must be constructed from, concrete or masonry.
4. The method of attaching or installing a finish, lining, ancillary element, or service installation to a building must not reduce the fire-resistance of that element to below that required.
5. Fire rated shafts are required to be enclosed at the top and bottom by construction having an FRL of not less than what the shaft requires (in both directions)
6. The concession granted under S5C15 results in the roof of the building not being required to be fire rated (the building is provided throughout with sprinklers). Notwithstanding, the Atrium provisions override this general concession in BCA Specification 5.
7. Lift shafts are required to be enclosed at the top of the shaft with fire rated construction having an FRL of 120/120/120.
8. Fire isolated exits are to be provided with a fire rated "lid" that achieves an FRL of 120/120/120.
9. Where roof lights are proposed they are required to be located not less than 3 metres from a roof light in an adjoining fire separated part; and must not be more than 20% of the area of the roof.
10. Any loadbearing internal walls or loadbearing fire walls are to be masonry or concrete.
11. External walls must be non-combustible construction. Non-loadbearing parts of an external wall that are more than 3m from a fire source feature need not be fire rated.
12. Internal columns in this building (being less than 25m in effective height) that are in the storey immediately below the roof, can be constructed as follows:
 - a. Building with a rise in storeys exceeding 3 – FRL 60/60/60
 - b. Building with a rise in storeys not exceeding 3 – no FRL

+ Appendix 2 – Fire Safety Measures

The following table is a list of the required fire safety measures within the building. These measures may be subject to further change pending the outcomes of the Fire Safety Engineering Review.

+ Statutory Fire Safety Measure	+ Design/Installation Standard	+ Proposed
Access Panels, Doors & Hoppers	BCA 2022 Amendment 2 Clause C4D14 AS 1530.4 – 2014 Manufacturer's Specifications	✓
Alarm Signalling Equipment	AS 1670.3 – 2018	✓
Automatic Fail-Safe Devices	BCA 2022 Amendment 2 Clause D3D26	✓
Automatic Fire Detection & Alarm System	BCA 2022 Amendment 2 Spec. 20 & 23 AS 1670.1 – 2018	✓
Automatic Fire Suppression Systems	BCA 2022 Amendment 2 Spec. 17 AS 2118.1 – 2017 or AS 2118.4, 6 – 2012	✓
Emergency Lifts	BCA 2022 Amendment 2 Clause E3D5 AS 1735.2 – 2001	✓
Emergency Lighting	BCA 2022 Amendment 2 Clauses E4D2 & E4D4 AS 2293.1 – 2018	✓
Emergency Evacuation Plan	AS 3745 – 2010	✓
Emergency Warning Intercom System (EWIS)	BCA 2022 Amendment 2 Clause E4D9 & Spec. 31 S31C19 AS 1670.4 – 2018	✓
Exit Signs	BCA 2022 Amendment 2 Clauses E4D5, NSWE4D6 & E4D8 AS 2293.1 – 2018	✓
Fire Control Rooms	BCA 2022 Amendment 2 Spec. 19	✓
Fire Blankets	BCA 2022 Amendment 2 Clause E1D14 AS 3504 – 1995 & AS 2444 – 2001	✓
Fire Dampers	BCA 2022 Amendment 2 Clause C4D15 AS 1668.1 – 2015 & AS 1682.1 & 2 – 2015 Manufacturer's Specification	✓
Fire Doors	BCA 2022 Amendment 2 Clauses C3D13, C3D14, C4D9 & C4D12 AS 1905.1 – 2015 Manufacturer's Specification	✓
Fire Hose Reels	BCA 2022 Amendment 2 Clause E1D3 AS 2441 – 2005	✓
Fire Hydrant Systems	BCA 2022 Amendment 2 Clause E1D2 AS 2419.1 – 2021	✓
Fire Seals	BCA 2022 Amendment 2 Clause C4D15 AS 1530.4 – 2014 & AS 4072.1 – 2014 Manufacturer's Specification	✓
Fire Shutters	BCA 2022 Amendment 2 Spec 12	TBC

+ Statutory Fire Safety Measure	+ Design/Installation Standard	+ Proposed
	AS 1905.2 – 2005	
Lightweight Construction	BCA 2022 Amendment 2 Clause C2D9 AS 1530.4 – 2014 Manufacturer’s Specification	✓
Mechanical Air Handling Systems (Automatic Shutdown)	BCA 2022 Amendment 2 Clause E2D3 AS/NZS 1668.1 – 2015 & AS 1668.2 – 2012	✓
Portable Fire Extinguishers	BCA 2022 Amendment 2 Clause E1D14 AS 2444 – 2001	✓
Smoke Alarms	BCA 2022 Amendment 2 Spec. 20 AS 3786 – 2014	✓
Smoke Hazard Management Systems - Stair Pressurisation.	BCA 2022 Amendment 2 Part E2 AS/NZS 1668.1 –2015	✓
Smoke Hazard Management Systems – Zone Smoke Control	BCA 2022 Amendment 2 Part E2 AS/NZS 1668.1 –2015	✓
Smoke Dampers	BCA 2022 Amendment 2 Spec. 11 AS/NZS 1668.1 – 2015	TBC
Warning & Operational Signs	BCA 2022 Amendment 2 Clauses D3D26, D3D28, D4D7, E4D4 AS 1905.1 – 2015 EP&A (DCFS) Regulation 2021 Section 108	✓
Fire Engineered Performance Solutions relating to: TBC	<i>To be developed</i>	✓

Please note that the above schedule will need to be revised prior to issue of the Building Approval to reference any proposed Fire Engineering Report and incorporate any additional measures required by the proposed Performance Solutions.