

ACCESS LINK CONSULTING

Solutions to last a lifetime

ACCESSIBILITY COMPLIANCE REPORT

For State Significant
Development Application -
SSDA

Project Address: 135 Badgerys Creek Rd, Bradfield NSW

Prepared For: Creative Vision

Issue No: C

Issue Date: 13/10/2025

Report No: SSDA-25039

Report Register:

The following report register documents the development and issue of this report as undertaken by Access Link Consulting Pty Ltd

Report No.	Issue No.	Issue Date	Report Details
SSDA-25039	A	14/09/2025	DRAFT Issue
SSDA-25039	B	21/09/2025	DRAFT Issue
SSDA-25039	C	13/10/2025	SSDA Issue

1.0 - Report Purpose:

This Accessibility report has been prepared on behalf of Bradfield Corporation Pty Ltd by Access Link Consulting Pty Ltd to accompany a State Significant Development Application (SSDA) for a mixed-use development for the site located at 135 Badgerys Creek Rd, Bradfield, **NSW**.

This report has been prepared in response to the Secretary's Environmental Assessment Requirements (SEARS) Ref. No. **SSD-77458970**.

The subject project achieves the spatial requirements to provide access for people with disability under the relevant standards and codes. It is required that a detailed assessment be undertaken covering, but not limited to, internal fit-out, details for stairs, ramps, finishes, amenities and other features to occur at CC "Construction Certificate" stage.

By adopting the recommendation set in this report, compliance with the report basis will be achieved and equitable and dignified access for all users of the building/facility will be provided.

2.0 – Project Description and Use:

The site is located at 135 Badgerys Creek Road, Bradfield and is approximately 2.02ha in area. It is legally described as Lot 7 DP 243457 and is located approximately 250m from the future Bradfield Metro Station and 4km from the Western Sydney Airport.

The site shares a western frontage with Badgerys Creek Road. The eastern boundary of the site adjoins the State government-led Bradfield City Centre, which is set to be a vibrant 24/7 global city, driving advancements in industry and will support 10,000 more homes and 20,000 new jobs in Western Sydney.

As defined by the Aerotropolis Precinct Plan, the site is located within the Aerotropolis Core Precinct, which is envisioned as an attractive place for workers, residents and visitors. The Aerotropolis Core Precinct will leverage the positive economic impact of the adjacent Western Sydney Airport and Bradfield City Centre. It will attract business hubs, research and development, professional services and creative industries in addition to providing residential development within walking distance of the Bradfield Metro station and proximity to blue and green infrastructure.

The proposed development will seek consent for the redevelopment of the site, comprising:

- Enabling works including vegetation removal and earthworks;
- The construction of three buildings, comprising:
 - Residential use, including approximately 400 apartment units;
 - Hotel use, including approximately 450 hotel rooms;
 - Commercial use, including supermarket, food and drink and other commercial uses;
 - Medical centre use;
 - Childcare centre use;
- Construction of two basement structures, including approximately 800 carparking spaces;
- Public domain upgrades, including:
 - Construction of an internal road;
 - A public plaza;
- Rehabilitation and augmentation of the existing riparian corridor;
- Landscaping embellishments on the ground level and within the built form; and
- Services augmentation as required.

Refer to the Environmental Impact Statement for a detailed summary of the proposed development.

3.0 – Project Classification:

This accessibility compliance report for a proposed building with classification as set below:

- Class 2 (Residential)
- Class 3 (Hotel)
- Class 5 (Office)
- Class 6 (Restaurant/café) (Retail) (Supermarket)
- Class 7a (Carparking)
- Class 7b (Storage)
- Class 8 (Substation)
- Class 9b (Childcare) (Gymnasium) (Tavern)

Note: The classification/s above is our understating of the relevant BCA classification/s. BCA consultant/certifier must confirm and determine the BCA classifications.

4.0 – Report Basis:

This report is based in the context of:

- National Construction Code 2022 Amd. 2, Volume One – Building Code of Australia (BCA).
 - D1P1, D1P2, D1P8, D1P9
 - E3P4
 - F4P1
 - Parts of D1, D4, E3 and F4
- AS 1428.1 – 2021
- AS 1428.4.1 – 2009
- AS 2890.6 – 2009
- AS 4299 – 1995
- AS 1735.12 – 1999
- Disability (Access to Premises-Building) Amended Standards 2010
- Australian Human Rights Commission’s Guidelines on application of APS version 2.
- Livable Housing Australia’s Livable Housing Design Guidelines – Fourth Edition

5.0 – Assessed Drawings:

Drawing No.	Drawing Title	Issue	Issue Date
DA-10B3	General Floor Plan –Basement 02	A	01/10/2025
DA-10B2	General Floor Plan –Basement 01	A	01/10/2025
DA-10B1	General Floor Plan –Lower Ground	A	01/10/2025
DA-10M1	General Floor Plan –Mezzanine	A	01/10/2025
DA-1000	General Floor Plan – Ground	A	01/10/2025
DA-1001	General Floor Plan – Level 01	A	01/10/2025
DA-1002	General Floor Plan – Level 02	A	01/10/2025
DA-1003	General Floor Plan – Level 03	A	01/10/2025
DA-1004	General Floor Plan – Level 04	A	01/10/2025
DA-1005	General Floor Plan – Level 05-08	A	01/10/2025
DA-1009	General Floor Plan – Level 09	A	01/10/2025
DA-1010	General Floor Plan – Level 10	A	01/10/2025
DA-1011	General Floor Plan – Level 11	A	01/10/2025
DA-6003	Pre & Post Adaptation Typologies – Sheet 01	A	01/10/2025
DA-6004	Pre & Post Adaptation Typologies – Sheet 02	A	01/10/2025
DA-6100	Hote Typologies Diagrams	A	01/10/2025

6.0 – Copyright

6.1 The contents of this report are copyright and prepared only for the attention of the client on this project. The rights to this report are owned by Access Link Consulting Pty Ltd.

- 6.2 The contents of this report contain Standard Australia Ltd copyrighted materials and must not be reproduced, sold, published, combined with external documents or altered without the prior written permission of its distributor, SAI Global Ltd and Access Link Consulting Pty Ltd.
- 6.3 This report may be reproduced in accordance with the terms of SAI Global Ltd License 1704-c045-2 to Access Link Consulting Pty Ltd.

7.0 – Exclusions and Liabilities

- 7.1 This Clause operates simultaneously with the terms set out in Access Link Consulting Pty Ltd.'s Fee Proposal/Cost Agreement.
- 7.2 Access Link Consulting Pty Ltd is only retained for the purpose of producing information relating to Access in the context of the codes, standards, regulations and guidelines listed in Clause 4.0 of this report. Access Link Consulting Pty Ltd is not liable for producing any other information outside this context.
- 7.3 The client acknowledges the following:
- 7.3.1 This report is solely for the purpose of reviewing, identifying and advising on Access issues/Access related provisions of the BCA.
- 7.3.2 This report does not identify or cover any information, compliance matters or issues that are related to other services associated to this project.
The client is aware that it is the architect's responsibility to coordinate and check all services against the information and requirements provided in this report to ensure that compliance has been met and achieved.
- 7.3.3 This report does not identify or cover any information, compliance matters or issues in relation to the construction stage of this project.
The client is aware that it is the builder's responsibility to coordinate and check that all the information and requirements provided in this report are met and achieved during the construction stage of this project.
- 7.3.4 This report does not identify or cover checks for:
- a) Slip resistance in surfaces such as set areas, parking areas, common spaces or stairs; and/or,
b) Wall reinforcement once the walls have already been constructed.
The client is aware that it is the builder's responsibility to ensure that the requirements are met as per AS 1428.1, AS 4299, AS 2890, AS 3661, AS 4586 and any other relevant codes that may arise.
- 7.3.5 Our Report does not assess compliance matters related to the following:
- a. Work, Health and Safety;
b. Structural design;
c. Service Design; and/or,
d. Parts of the Disability Discrimination Act other than those that relate to the APS, Parts of BCA or Parts of AS other than those directly referenced in our Report.
- 7.3.6 Access Link Consulting Pty Ltd does not guarantee or warrant that our Report is correct or complete and will not be liable for any losses arising from the reliance upon or use of our Report.
- 7.3.7 Should the Client engage services with another certifier or access consultant, we are not liable if that certifier or access consultant comes to a different conclusion in their report.
- 7.4 Access Link Consulting Pty Ltd is therefore not liable for any other services that are associated to this project.
- 7.5 Except as required by law, Access Link Consulting Pty Ltd is not liable for any inaccurate or incorrect information in this report supplied by SAI Global Ltd.
- 7.6 This document/report is based on the classification of this project and the drawings set out in Clause 6.0 of this report. In the event that changes are made to the classification or drawings, this report will be deemed invalid and will be required to be updated accordingly.

Yours Sincerely,

Assessed by

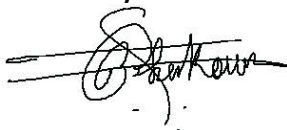

Rami Shakour

Director

ACA No. 488

Checklist Assessment Related to the Requirements Set in the BCA

The extract clauses from the NCC 2022 Amd. 2 Volume 1 – BCA below to be read in full format as set in the National Construction Code 2022 Amd. 2 Volume 1 – Building Code of Australia.

Part D3 – Construction of exits

D3D22 Handrails

ADR

N/A

C

In a Class 9b building used as a primary school or a building that contains an early childhood centre except for handrails referenced in D3D23, handrails must:

Class 9b

- | | | | | |
|------|---|--------------------------|--------------------------|--------------------------|
| I. | Have a handrail fixed at a height of not less than 865mm | <input type="checkbox"/> | <input type="checkbox"/> | ✓ |
| II. | In addition to (i), have a handrail | <input type="checkbox"/> | ✓ | <input type="checkbox"/> |
| | (a) fixed at a height between 665 mm and 750 mm in a primary school | <input type="checkbox"/> | <input type="checkbox"/> | ✓ |
| | (b) With a cross-sectional dimension not less than 16mm and not greater than 45mm as measured in any direction across its centre and fixed at a height between 450mm and 700mm in a Class 9b early childhood centre | <input type="checkbox"/> | <input type="checkbox"/> | <input type="checkbox"/> |
| III. | In any other case, be fixed at a height of not less than 865 mm; and | <input type="checkbox"/> | <input type="checkbox"/> | ✓ |
| IV. | Be continuous between stair flight landings and have no obstruction on or above them that will tend to break a hand-hold | <input type="checkbox"/> | <input type="checkbox"/> | ✓ |

Notes: See Att. 01 – Can be compliant at CC stage

D3D26 Operation of latch

ADR

N/A

C

The requirements of (1) and (2) do not comply for a door that complies with (4) and serves:

Class 9b

- | | | | | |
|-----|--|--------------------------|--------------------------|---|
| I. | The secure parts of an early childhood centre; and | <input type="checkbox"/> | <input type="checkbox"/> | ✓ |
| II. | Can be immediately unlocked by hand by a person/s, specifically nominated by the owner unlocked properly instructed as to the duties and responsibilities involved and available at all times when the building is lawfully occupied so that persons in the building or part may immediately escape if there is a fire | <input type="checkbox"/> | <input type="checkbox"/> | ✓ |

Notes: See Att. 01 – Can be compliant at CC stage

<p>Class 9b – Schools and early childhood centres</p> <ul style="list-style-type: none"> To and within all areas normally used by the occupants <p>Notes: See Att. 01 – Shown on plans The main entry is accessible by means of of a step-free continuous accessible path of travel. Furthermore, all common areas that are used by occupants are accessible.</p>	<input type="checkbox"/>	<input type="checkbox"/>	<input checked="" type="checkbox"/>
D4D3 Access To Buildings	ADR	N/A	C
<p>(a) Access way must be provided to a building;</p> <ol style="list-style-type: none"> From the main points of a pedestrian entry at the allotment boundary From another accessible building connected by a pedestrian link From any required accessible car parking space on the allotment <p>Reference: Figure 16, Figure 18, Figure 18(A), Figure 19 Notes: See Att. 01 – can be compliant at the CC stage Access way is provided from the allotment boundary via means of a step-free continuous accessible path of travel, stairs and walkways</p>	<input type="checkbox"/> <input type="checkbox"/> <input type="checkbox"/>	<input type="checkbox"/> <input type="checkbox"/> <input type="checkbox"/>	<input checked="" type="checkbox"/> <input checked="" type="checkbox"/> <input checked="" type="checkbox"/>
<p>(b) In a building required to be accessible,</p> <ol style="list-style-type: none"> an accessway must be provided through the principal pedestrian entrance, through not less than 50% of all pedestrian entrances including the principal pedestrian entrance; and in a building with a total floor area more than 500 m2, a pedestrian entrance which is not accessible must not be located more than 50 m from an accessible pedestrian entrance. <p>Notes: See Att. 01 – can be compliant at the CC stage Access way is provided through the main principal pedestrian entrance via means of a step-free continuous accessible path of travel, stairs and walkways</p>	<input type="checkbox"/> <input type="checkbox"/> <input type="checkbox"/>	<input type="checkbox"/> <input type="checkbox"/> <input checked="" type="checkbox"/>	<input checked="" type="checkbox"/> <input checked="" type="checkbox"/> <input type="checkbox"/>
<p>(c) Where a pedestrian entrance required to be accessible has multiple doorways—</p> <ol style="list-style-type: none"> if the pedestrian entrance consists of not more than 3 doorways — not less than 1 of those doorways must be accessible; if a pedestrian entrance consists of more than 3 doorways — not less than 50% of those doorways must be accessible <p>Notes: See Att. 01 – can be compliant at the CC stage</p>	<input type="checkbox"/> <input type="checkbox"/>	<input type="checkbox"/> <input checked="" type="checkbox"/>	<input checked="" type="checkbox"/> <input type="checkbox"/>
<p>(d) Access way must have a clear opening of 850mm in accordance with 1428.1</p> <p>Reference: Figure 29, Figure 29(A), Figure 29(B) Notes: See Att. 01 – can be compliant at the CC stage</p>	<input type="checkbox"/>	<input type="checkbox"/>	<input checked="" type="checkbox"/>
D4D4 Access To Buildings	ADR	N/A	C
<p>(a) every ramp and stairway must comply with;</p> <ol style="list-style-type: none"> For a ramp, clause 7 of AS 1428.1 For a stairway, clause 8 of AS 1428.1 For a fire isolated stair, clause 8.1 (f) and (g) of AS 1428.1 <p>Reference: Figure 06, Figure 07, Figure 08, Figures 11 to 21 Notes: See Att. 01 – can be compliant at the CC stage</p>	<input type="checkbox"/> <input type="checkbox"/> <input type="checkbox"/>	<input type="checkbox"/> <input type="checkbox"/> <input type="checkbox"/>	<input checked="" type="checkbox"/> <input checked="" type="checkbox"/> <input checked="" type="checkbox"/>
<p>(b) every passenger lift must comply with E3D7 and E3D8</p> <p>Notes: Can be compliant at the CC stage – This has been assessed in further detail in Part E3, further in this report</p>	<input type="checkbox"/>	<input type="checkbox"/>	<input checked="" type="checkbox"/>
<p>(c) access ways must have;</p> <ol style="list-style-type: none"> Passing spaces complying with AS 1428.1 Turning spaces complying with AS 1428.1 <ol style="list-style-type: none"> Within 2m of the end of access ways where it is not possible to continue. at maximum 20m intervals along the access way <p>Reference: Figure 01, Figure 02, Figure 03 Notes: See Att. 01 – can be compliant at the CC stage</p>	<input type="checkbox"/> <input type="checkbox"/> <input type="checkbox"/>	<input type="checkbox"/> <input type="checkbox"/> <input type="checkbox"/>	<input checked="" type="checkbox"/> <input checked="" type="checkbox"/> <input checked="" type="checkbox"/>

(d) an intersection of access way satisfies the spatial requirements for a passing and turning space Reference: Figure 01 Notes: See Att. 01 – can be compliant at the CC stage	<input type="checkbox"/>	<input type="checkbox"/>	<input checked="" type="checkbox"/>															
(e) a passing space may serve as a turning space Reference: Figure 01 Notes: See Att. 01 – can be compliant at the CC stage	<input type="checkbox"/>	<input type="checkbox"/>	<input checked="" type="checkbox"/>															
(f) a ramp complying with AS 1428.1 or a passenger lift need not be provided to serve a storey or level other than the entrance storey in class 5, 6, 7b or 8 I. Containing not more than 3 storeys and II. With a floor area for each storey, excluding the entrance storey, of not more than 200m ²	<input type="checkbox"/>	<input checked="" type="checkbox"/>	<input type="checkbox"/>															
Slip Resistance Requirements as per the BCA BCA table D3D15 has the following slip resistance requirements/classification when tested in accordance with AS4586 Table D3D15: Slip-resistance classification	<input type="checkbox"/>	<input type="checkbox"/>	<input checked="" type="checkbox"/>															
<table border="1"> <thead> <tr> <th>Application</th> <th>Dry surface conditions</th> <th>Wet surface conditions</th> </tr> </thead> <tbody> <tr> <td>Ramp steeper than 1:14</td> <td>P4 or R11</td> <td>P5 or R12</td> </tr> <tr> <td>Ramp steeper than 1:20 but not steeper than 1:14</td> <td>P3 or R10</td> <td>P4 or R11</td> </tr> <tr> <td>Tread or landing surface</td> <td>P3 or R10</td> <td>P4 or R11</td> </tr> <tr> <td>Nosing or landing edge strip</td> <td>P3</td> <td>P4</td> </tr> </tbody> </table>	Application	Dry surface conditions	Wet surface conditions	Ramp steeper than 1:14	P4 or R11	P5 or R12	Ramp steeper than 1:20 but not steeper than 1:14	P3 or R10	P4 or R11	Tread or landing surface	P3 or R10	P4 or R11	Nosing or landing edge strip	P3	P4			
Application	Dry surface conditions	Wet surface conditions																
Ramp steeper than 1:14	P4 or R11	P5 or R12																
Ramp steeper than 1:20 but not steeper than 1:14	P3 or R10	P4 or R11																
Tread or landing surface	P3 or R10	P4 or R11																
Nosing or landing edge strip	P3	P4																
Notes: Can be compliant at the CC stage – the builder must provide a certificate stating that the slip resistance of all surfaces complies with the above table D3D15 when tested in accordance with AS4586																		
Carpet pile height and thickness The carpet pile height or pile thickness dimension, carpet backing thickness dimension and their combined dimension are shown in Figure 04 Reference: Figure 04 Notes: See Att. 01 – can be compliant at the CC stage	<input type="checkbox"/>	<input type="checkbox"/>	<input checked="" type="checkbox"/>															
D4D5 Exemptions	ADR	N/A	C															
Areas are not required to be accessible; (a) when access is not inappropriate because of particular purpose for which the area is used (b) an area which poses a health or safety risk for people with disability (c) path of travel providing access only to an area exempt by (a) or (b) Notes: Areas such as plant rooms, waste rooms serviced via a chute, service cupboards, tank rooms, substation and the like are not required to be accessible	<input type="checkbox"/>	<input type="checkbox"/>	<input checked="" type="checkbox"/>															
D4D6 Accessible car parking	ADR	N/A	C															
(a) Accessible parking spaces must be provided; I. Class 7a required to be accessible II. A car parking area on the same allotment as a building required to be accessible (b) Not required in class 7a where a parking service is provided and direct access to any of the car parking spaces is not available to the public. (c) must comply AS/NZS 2890.6 (d) need not be identified with signage where there is a total of not more than 5 carparking spaces, so as to restrict the use of the carparking space only for people with a disability. Reference: Figure 26, Figure 27, Figure 28 Notes: See Att. 01 – 55 accessible parking spaces are required and have been provided and can be compliant at the CC stage.	<input type="checkbox"/> <input type="checkbox"/> <input type="checkbox"/> <input type="checkbox"/>	<input type="checkbox"/> <input checked="" type="checkbox"/> <input type="checkbox"/> <input checked="" type="checkbox"/>	<input checked="" type="checkbox"/> <input type="checkbox"/> <input checked="" type="checkbox"/> <input type="checkbox"/>															

<p>Class 2 building</p> <p>There are no requirements set under the BCA for class 2 building, However, Liverpool City Council DCP states:</p> <p>10% of all apartments are to be designed to be capable of adaptation for disabled or elderly residents. Dwellings must be designed in accordance with the Australian Adaptable Housing Standard (AS 4299-1995), which includes 'pre-adaptation' design details to ensure visit ability is achieved.</p> <p>Notes: See Att. 01 – 42 accessible parking spaces are required and have been provided and can be compliant at the CC stage.</p>	<input type="checkbox"/>	<input type="checkbox"/>	✓
<p>Class 3 building</p> <p>(a) Boarding house, guest house, hostel, lodging house, backpacker's accommodation, or the residential part of a hotel or motel</p> <p>To be calculated by multiplying the total number of car parking spaces by the percentage of—</p> <p>(i) Accessible sole-occupancy units to the total. number of sole-occupancy units; or</p> <p>(ii) accessible bedrooms to the total number of bedrooms; and</p> <p>The calculated number is to be taken to the next whole figure.</p> <p>Notes: See Att. 01 – The percentage of the total number of accessible units has been divided against the total units for the development and then multiplied by the total number of parking spaces provided. Based on this calculation, a total of 8 accessible parking spaces are required and have been provided and can be compliant at the CC stage.</p>	<input type="checkbox"/>	<input type="checkbox"/>	✓
<p>Class 5</p> <p><i>1 space for every 100 carparking spaces or part thereof</i></p> <p>Notes: See Att. 01 – 1 accessible parking space is required and has been provided, and can be compliant at the CC stage</p>	<input type="checkbox"/>	<input type="checkbox"/>	✓
<p>Class 6</p> <p><i>1 space for every 50 carparking spaces or part thereof</i></p> <p>Notes: See Att. 01 – 3 accessible parking spaces are required and have been provided, 2x are provided for the retail section and 1x for the medical centre, and can be compliant at the CC stage</p>	<input type="checkbox"/>	<input type="checkbox"/>	✓
<p>Class 9b</p> <p><i>1 space for every 100 carparking spaces or part thereof</i></p> <p>Notes: See Att. 01 – 1 accessible parking space is required and have been provided, and can be compliant at the CC stage</p>	<input type="checkbox"/>	<input type="checkbox"/>	✓
D4D7 Signage	ADR	N/A	C
<p>(a) braille and tactile signage must incorporate the international symbol of access or deafness in accordance with AS 1428.1 and identify:</p> <p>I. sanitary facility (except within a sole-occupancy unit in a Class 1b or Class 3 building)</p> <p>II. Space with a hearing augmentation system.</p> <p>III. Identify each door required by E4D5 with an exit sign which states: "Exit" and "Level" followed by (a) the floor level number; or (b) a floor level descriptor; or (c) a combination of (a) and (b);</p> <p>Reference: Figure 23, Figure 24</p> <p>Notes: See Att. 01 – can be compliant at the CC stage</p>	<input type="checkbox"/>	<input type="checkbox"/>	✓
<p>(b) signage including the international symbol for deafness in accordance with AS 1428.1 must be provided within a room containing a hearing augmentation system identifying—</p> <p>I. The type of hearing augmentation.</p> <p>II. The area covered within the room.</p> <p>If receivers are being used and where the receivers can be obtained.</p> <p>Notes: See Att. 01 – Details to be added and can be compliant at the CC stage</p>	<input type="checkbox"/>	<input type="checkbox"/>	✓

(c) Signage in accordance with AS 1428.1 must be provided for accessible unisex sanitary facilities to identify if the facility is suitable for left (LH) or right (RH) handed use. Reference: Figure 23 Notes: See Att. 01 – ‘LH’ & ‘RH’ accessible WC’s have been provided and can be compliant at the CC stage.	<input type="checkbox"/>	<input type="checkbox"/>	<input checked="" type="checkbox"/>
(d) Signage to identify an ambulant accessible sanitary facility in accordance with AS 1428.1 must be located on the door of the facility. Reference: Figure 23 Notes: See Att. 01 – can be compliant at CC stage	<input type="checkbox"/>	<input type="checkbox"/>	<input checked="" type="checkbox"/>
(e) where a pedestrian entrance is not accessible, directional signage in accordance with AS 1428.1 must be provided to direct a person to the location of the nearest accessible pedestrian entrance.	<input type="checkbox"/>	<input checked="" type="checkbox"/>	<input type="checkbox"/>
(f) where a bank of sanitary facilities is not provided with an accessible unisex sanitary facility, directional signage in accordance with AS 1428.1 must be placed at the location of the sanitary facilities that are not accessible, to direct a person to the location of the nearest accessible unisex sanitary facility.	<input type="checkbox"/>	<input checked="" type="checkbox"/>	<input type="checkbox"/>
g) in a building subject to F4D12, directional signage complying with Specification D4D7 must be provided at the location of each— i. bank of sanitary facilities; and ii. accessible unisex sanitary facility, other than one that incorporates an accessible adult change facility, to direct a person to the location of the nearest accessible adult change facility within that building. Notes: Capable of compliance at the CC stage. Details to be added to the signage location, and requirements to be added to the plans	<input type="checkbox"/> <input type="checkbox"/>	<input type="checkbox"/> <input checked="" type="checkbox"/>	<input checked="" type="checkbox"/> <input type="checkbox"/>
All braille and tactile signage must comply with Specification D4D7 braille and tactile signs Reference: Figure 25 Notes: See Att. 01 – Notes on plans	<input type="checkbox"/>	<input type="checkbox"/>	<input checked="" type="checkbox"/>
D4D8 Hearing augmentation	ADR	N/A	C
(a) a hearing augmentation system must be provided where an inbuilt amplification system other than the one used only for emergency warning, is installed; I. In a room in a Class 9b building II. In an auditorium, conference room, meeting room or room for judicatory purposes III. At any ticket office, teller’s booth, reception area or the like, where the public is screened from the service provider Notes: Details and compliance can be achieved at the CC stage by specifying the hearing augmentation type and location	<input type="checkbox"/> <input type="checkbox"/> <input type="checkbox"/>	<input checked="" type="checkbox"/> <input type="checkbox"/> <input checked="" type="checkbox"/>	<input type="checkbox"/> <input checked="" type="checkbox"/> <input type="checkbox"/>
D4D9 Tactile indicators	ADR	N/A	C
(a) For a building required to be accessible, tactile ground surface indicators must be provided to warn people who are blind or have a vision impairment that they are approaching— I. A stairway, other than a fire-isolated stairway. II. An escalator. III. A passenger conveyor or moving walk. IV. A ramp other than a fire-isolated ramp, step ramp, kerb ramp or swimming pool ramp. V. Under an overhead obstruction less than 2 m above floor level, other than a doorway if no barrier is present. VI. Or when an access way meets a vehicular way adjacent to any pedestrian entrance to a building, if there is no kerb or kerb ramp present. Reference: Figure 05, Figure 06, Figure 07, Figure 08, Figure 09, Figure 10 Notes: See Att. 01 – can be compliant at the CC stage	<input type="checkbox"/> <input type="checkbox"/> <input type="checkbox"/> <input type="checkbox"/> <input type="checkbox"/> <input type="checkbox"/>	<input type="checkbox"/> <input checked="" type="checkbox"/> <input type="checkbox"/> <input type="checkbox"/> <input checked="" type="checkbox"/> <input type="checkbox"/>	<input checked="" type="checkbox"/> <input type="checkbox"/> <input checked="" type="checkbox"/> <input checked="" type="checkbox"/> <input type="checkbox"/> <input checked="" type="checkbox"/>

(b) Tactile ground surface indicators must comply with sections 1 and 2 of AS/NZS 1428.4.1. Reference: Figure 05 Notes: See Att. 01 – can be compliant at CC stage	<input type="checkbox"/>	<input type="checkbox"/>	✓
(c) A hostel for the aged, nursing home for the aged, a residential aged care building Class 3 accommodation for the aged, Class 9a health-care building or a Class 9c building need not comply with (a)(i) and (iv) if handrails incorporating a raised dome button in accordance with the requirements for stairway handrails in AS 1428.1 are provided to warn people who are blind or have a vision impairment that they are approaching a stairway or ramp.	<input type="checkbox"/>	✓	<input type="checkbox"/>
D4D10 Wheelchair seating spaces in Class 9b assembly buildings	ADR	N/A	C
Only applicable for class 9b building	<input type="checkbox"/>	✓	<input type="checkbox"/>
D4D11 Swimming pools	ADR	N/A	C
Only applicable where swimming pool is provided	<input type="checkbox"/>	<input type="checkbox"/>	✓
D4D12 Ramps	ADR	N/A	C
(a) a series of connected ramps must not have a combined vertical rise of more than 3.6m	<input type="checkbox"/>	<input type="checkbox"/>	✓
(b) a landing for a step ramp must not overlap a landing for another step ramp or ramp	<input type="checkbox"/>	✓	<input type="checkbox"/>
Notes: See Att. 01 – can be compliant at the CC stage			
D4D13 Glazing on an access way	ADR	N/A	C
On an access way where there is no chair rail, handrail or transom, all frameless or fully glazed doors, sidelights and any glazing capable of being mistaken for a doorway or opening, must be clearly marked in accordance with AS 1428.1 Reference: Figure 22 Notes: Compliance can be achieved at the CC stage – selecting glazing strips as specified in this section will ensure compliance at the construction stage. This is to be confirmed at the CC stage.	<input type="checkbox"/>	<input type="checkbox"/>	✓



Class 3 Requirements in accordance with AS1428.1

✓ (R) Required

✓ (C) Compliant

No.	AS1428.1 Requirements	R	C	Comments
1	<p>Doorways</p> <p>All doors including main entry door is to be provided with 850mm clear opening and to comply with doorway circulation spaces and fixtures as specified in AS1428.1</p>	✓	✓	See Att. 01 – Shown on plans
2	<p>Bathroom</p> <p>At least one bathroom has been provided and accomodatedes a WC pan, shower and hand wash basin. All fixtures and fittings including grabrails are to be in accordance with AS1428.1</p>	✓	✓	See Att. 01 – Shown on plans
3	<p>Laundry</p> <p>1550mm circulation space is to be provided in front of the laundry appliances.</p>	✓	✓	See Att. 01 – Shown on plans
4	<p>Main Bedroom</p> <p>At least one bedroom is to accommodate a queen size bed with 1540x2070mm circulation space on one side of the bed and 1000mm on the other 2 sides of the bed. A boarding house may accommodate for a single bed – the circulation spaces will still apply.</p>	✓	✓	See Att. 01 – Shown on plans
5	<p>Living Areas</p> <p>2250mm minimum circulation is required in the living area clear of any furniture.</p>	✓	✓	See Att. 01 – Shown on plans
6	<p>Kitchen/Kitchenette</p> <p>Where an internal kitchenette is provided, 1550mm circulation space is to be provided in front of the benchtops.</p> <p>A lever style tapware is to be provided 300mm from the edge of the bench.</p> <p>X1 DGPO is to be provided within 300mm of the front bench.</p> <p>Consideration is to be given to the provision of an 850mm section without any cabinetry installed to allow for an accessible benchtop with 800mm space between the fridge and cooktop.</p>	✓	✓	See Att. 01 – Shown on plans
7	<p>Balconies & Outdoor Areas</p> <p>Where access is provided from the unit to the outdoor areas such as balconies, courtyards, etc, a step free transition is required to be provided otherwise a 35mm threshold ramp is to be provided in accordance with AS1428.1</p>	✓	✓	See Att. 01 – Shown on plans

8	<p>Flooring</p> <p>All accessways are required to be provided with step free transition. Construction tolerances, slip resistance and waterproofing are to comply with the relevant Standards & the NCC.</p>	✓	✓	See Att. 01 – Shown on plans
9	<p>Switches & GPO's</p> <p>All switches, GPO's and controls (incl. but not limited to intercom facilities) are to be accessible as required by AS1428.1.</p>	✓	✓	See Att. 01 – Shown on plans
10	<p>Visual Indicators</p> <p>The contrasting line shall be not less than 75mm wide and must extend across the full width of the glazing panel. The lower edge of the contrasting line is to be located between 900mm and 1000mm above the plan FFL.</p>	✓	✓	See Att. 01 – Shown on plans



Part D4 – References

The references below to be read as set and referenced in each section of part D4

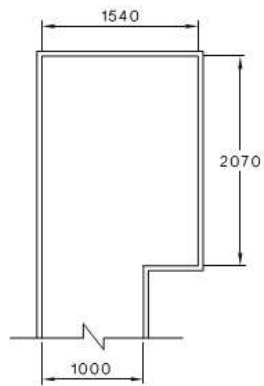

(a) Space required in corridor

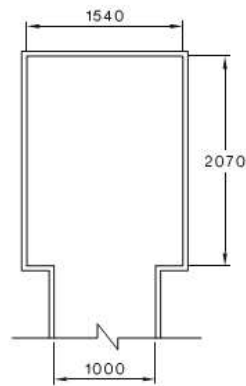

(b) Space required in corridor

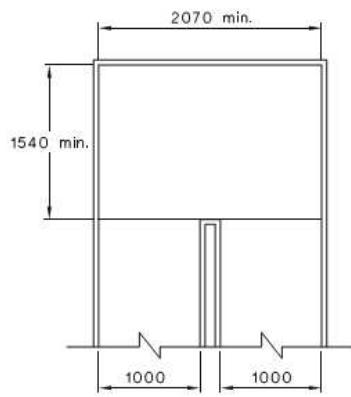

(c) Space required at ramp landing

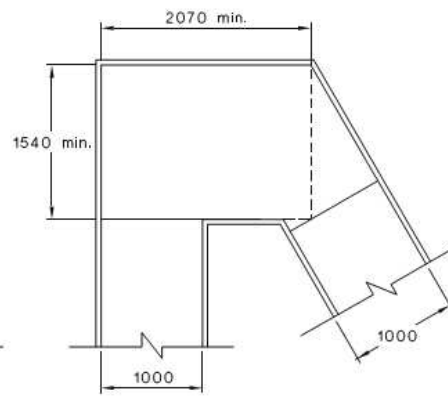

(d) Space required at ramp landing

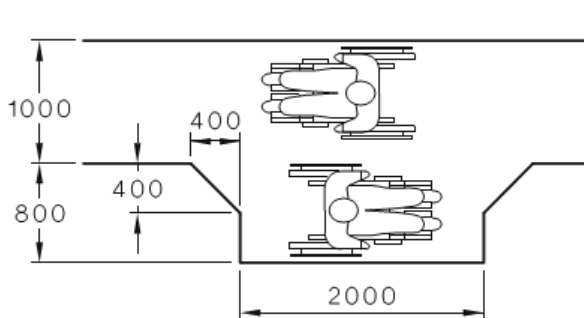
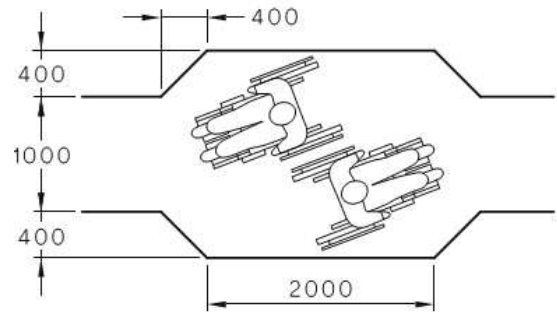

Figure 01



SAI Global Ltd License 1704-c045-2

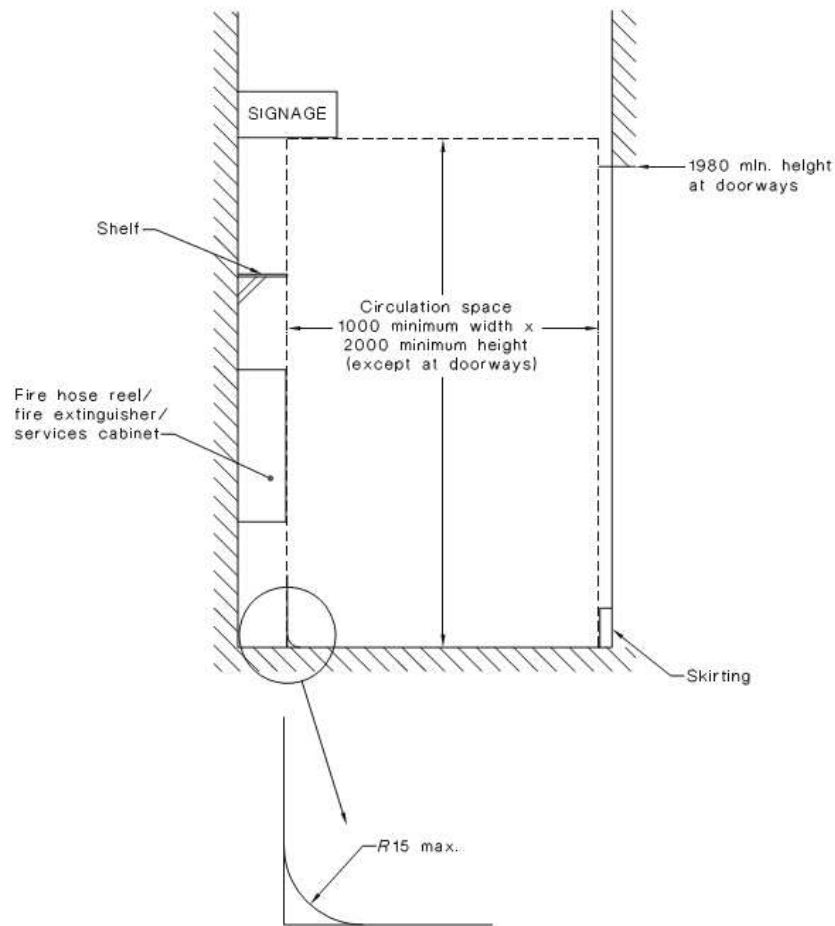

Figure 02

SAI Global Ltd License 1704-c045-2

Unless otherwise specified (such as at doors, curved ramps and similar), the minimum unobstructed width (see Figure 2) of a continuous accessible path of travel shall be 1000 mm and the following shall not intrude into the minimum unobstructed width of a continuous accessible path of travel:

- (a) Fixtures and fittings such as lights, awnings, windows that, when open, intrude into the circulation space, telephones, skirtings and similar objects.
- (b) Essential fixtures and fittings such as fire hose reels, fire extinguishers and switchboards.
- (c) Door handles less than 900 mm above the finished floor level.

Figure 03

SAI Global Ltd License 1704-c045-2

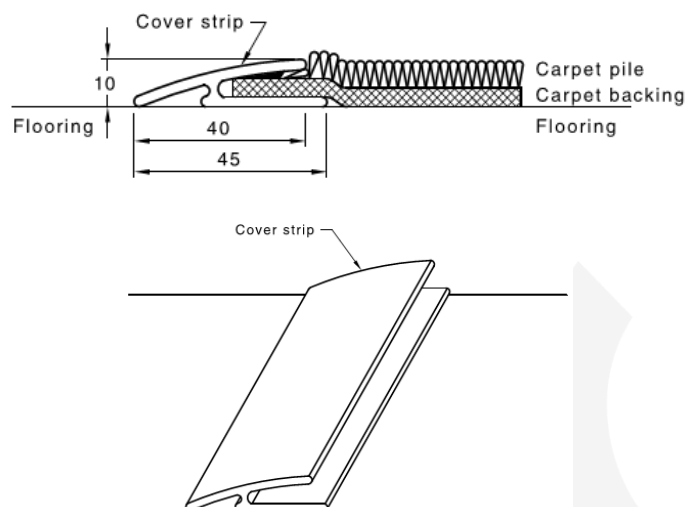

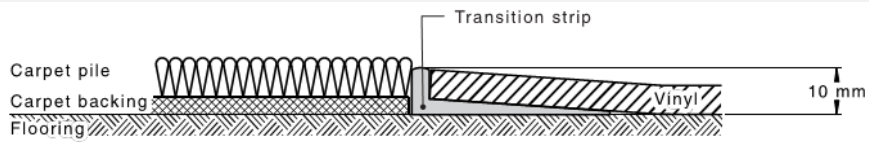

Figure 04

SAI Global Ltd License 1704-c045-2

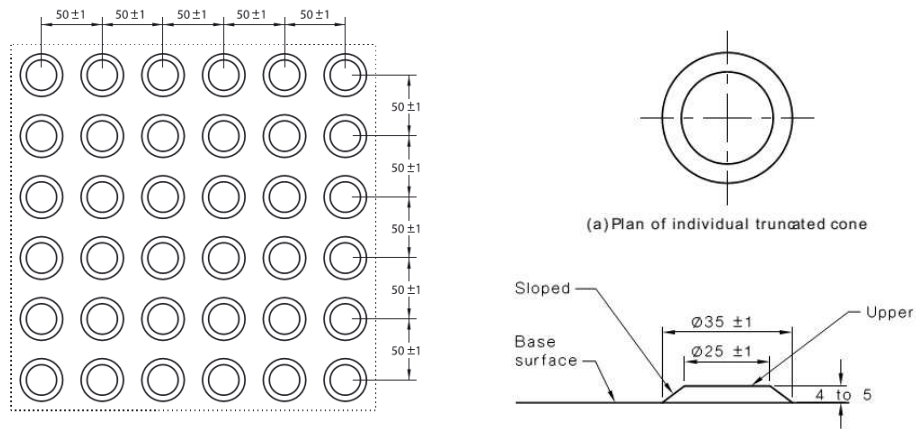

Figure 05

SAI Global Ltd License 1704-c045-2

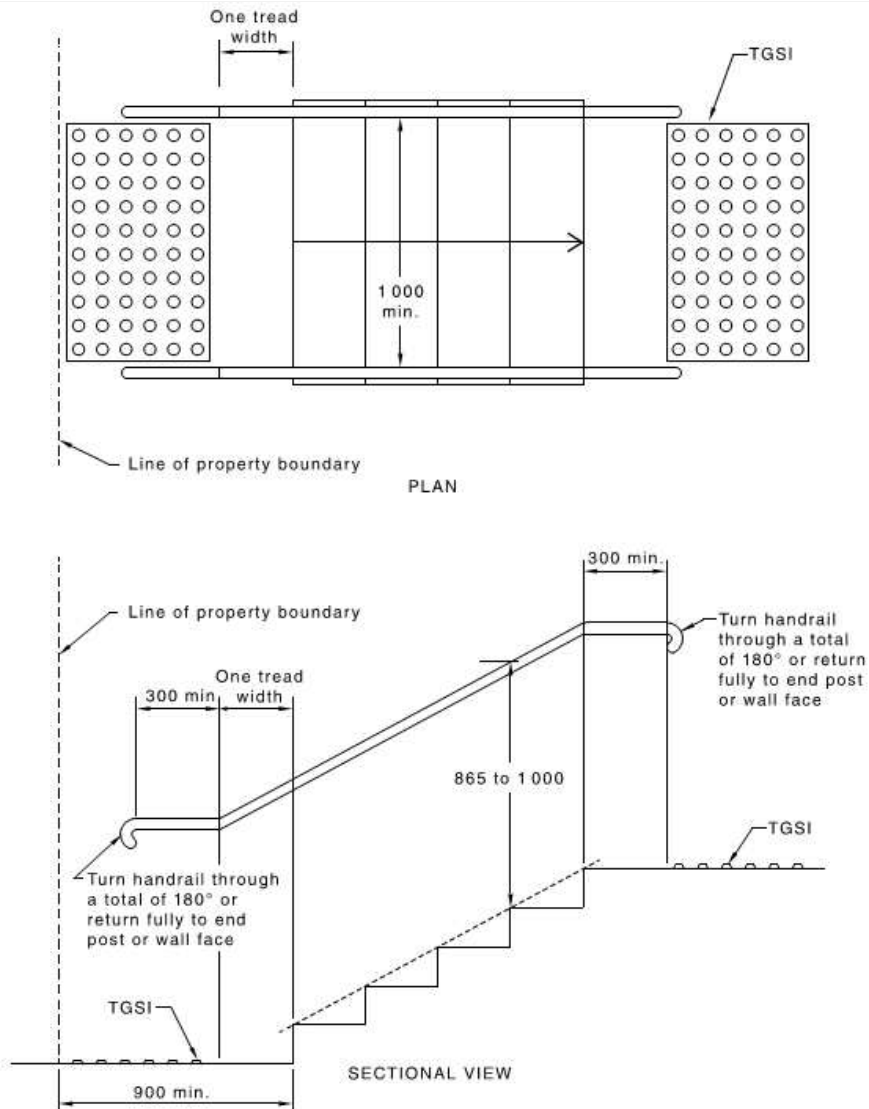
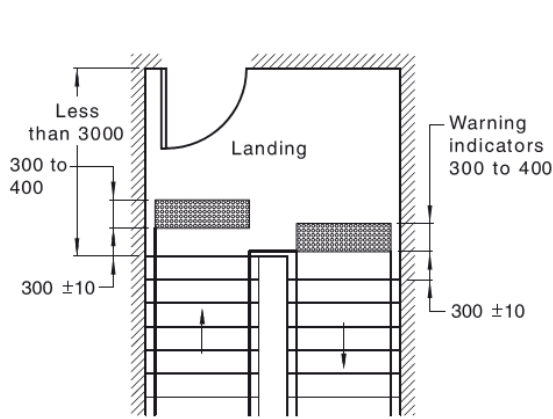

Figure 06

SAI Global Ltd License 1704-c045-2



(a) Plan of warning tactiles at a stairway landing less than 3000 with no continuous outer handrail

Figure 07

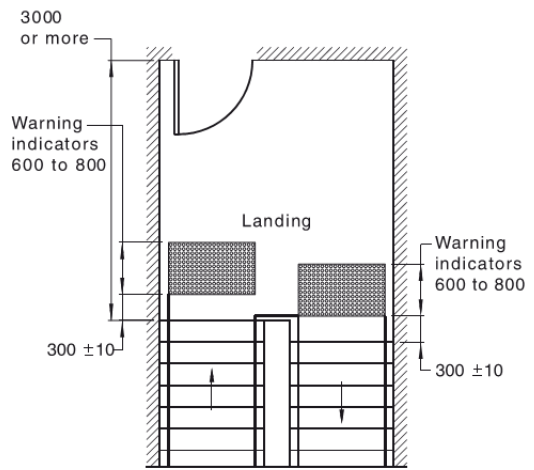

(b) Plan of warning tactiles at a stairway landing 3000 or more

SAI Global Ltd License 1704-c045-2

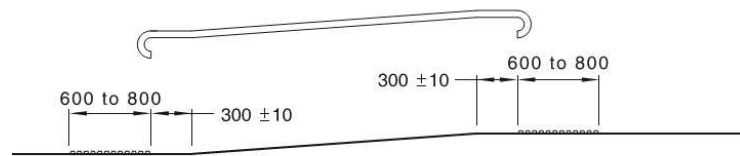

(c) Side elevation where top and bottom of ramp leads to an open area

Figure 08

SAI Global Ltd License 1704-c045-2

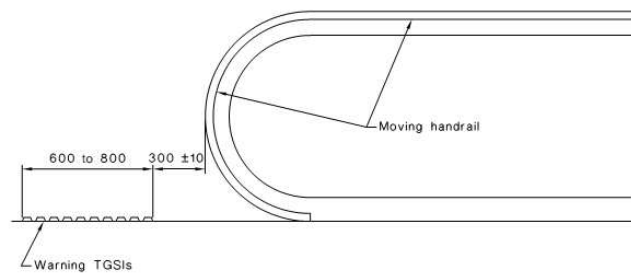

(b) Part elevation of escalators / moving walks

Figure 09

SAI Global Ltd License 1704-c045-2

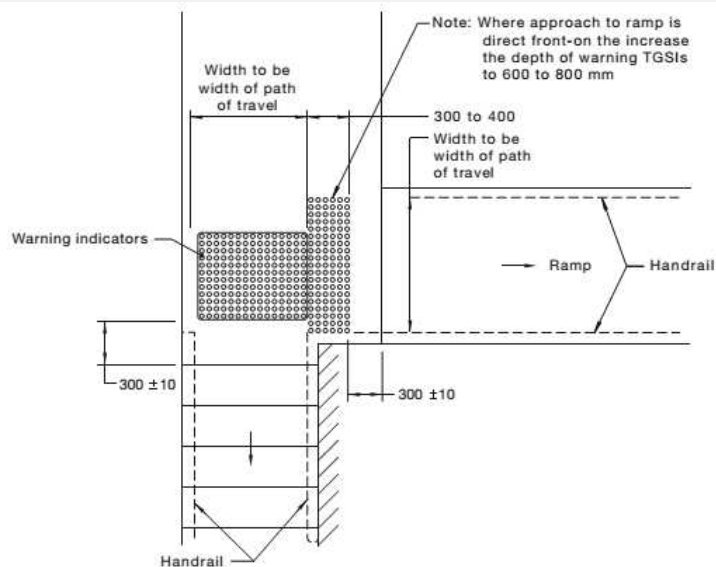

Figure 10

SAI Global Ltd License 1704-c045-2

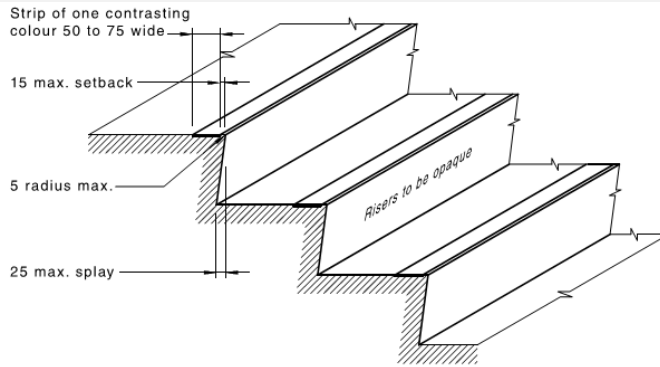

Figure 11

SAI Global Ltd License 1704-c045-2

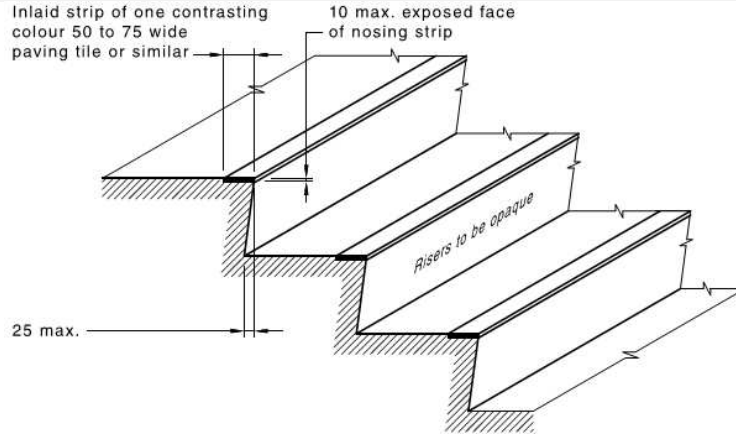
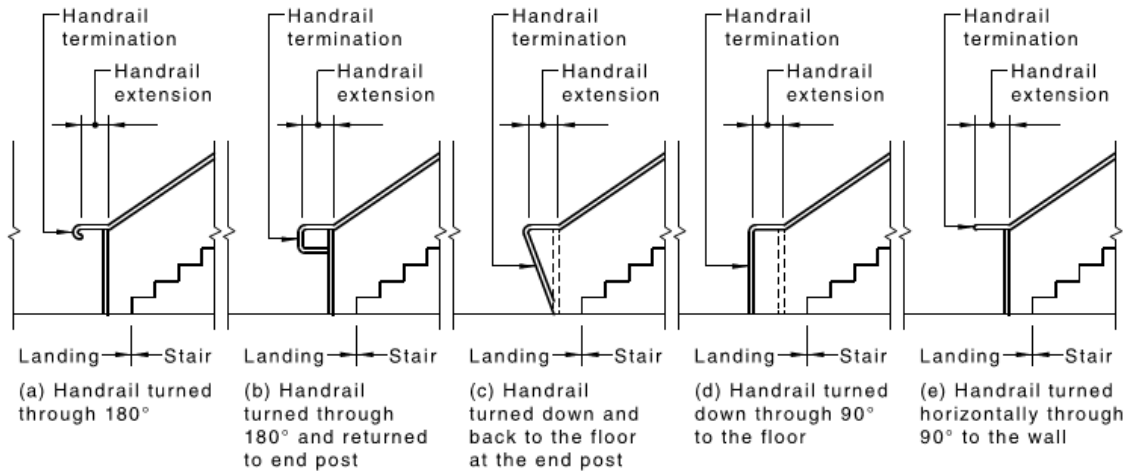

Figure 12

SAI Global Ltd License 1704-c045-2



Side elevations

(a) Examples of post mounted handrails

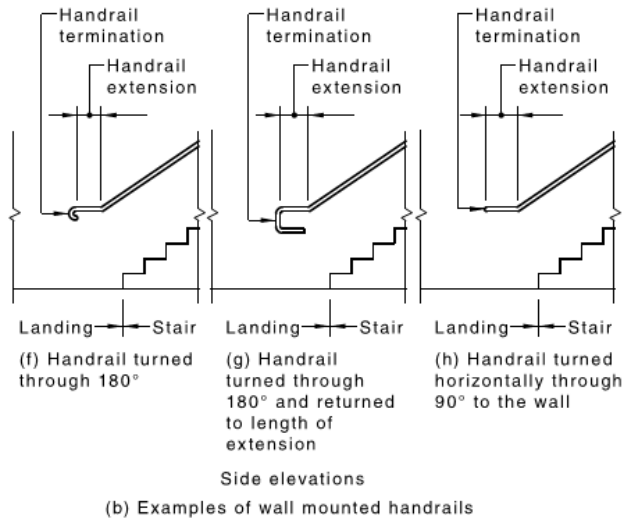

Stair handrails – Example of handrail termination

Figure 14

SAI Global Ltd License 1704-c045-2

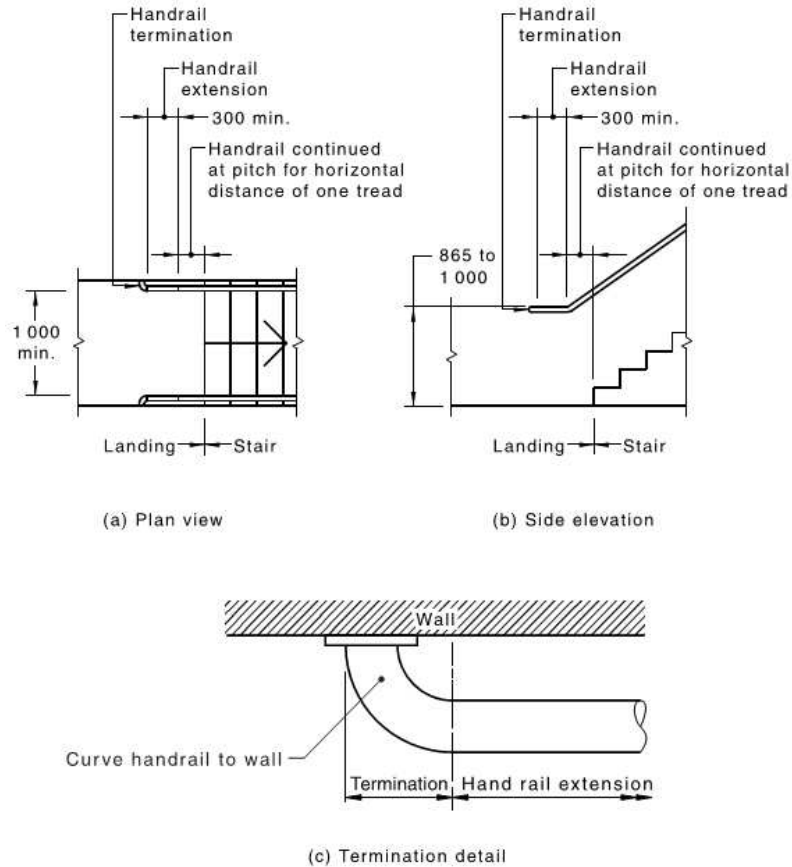

Example of detail for handrails terminated by turning horizontally through 90 degrees to the wall

Figure 15

SAI Global Ltd License 1704-c045-2

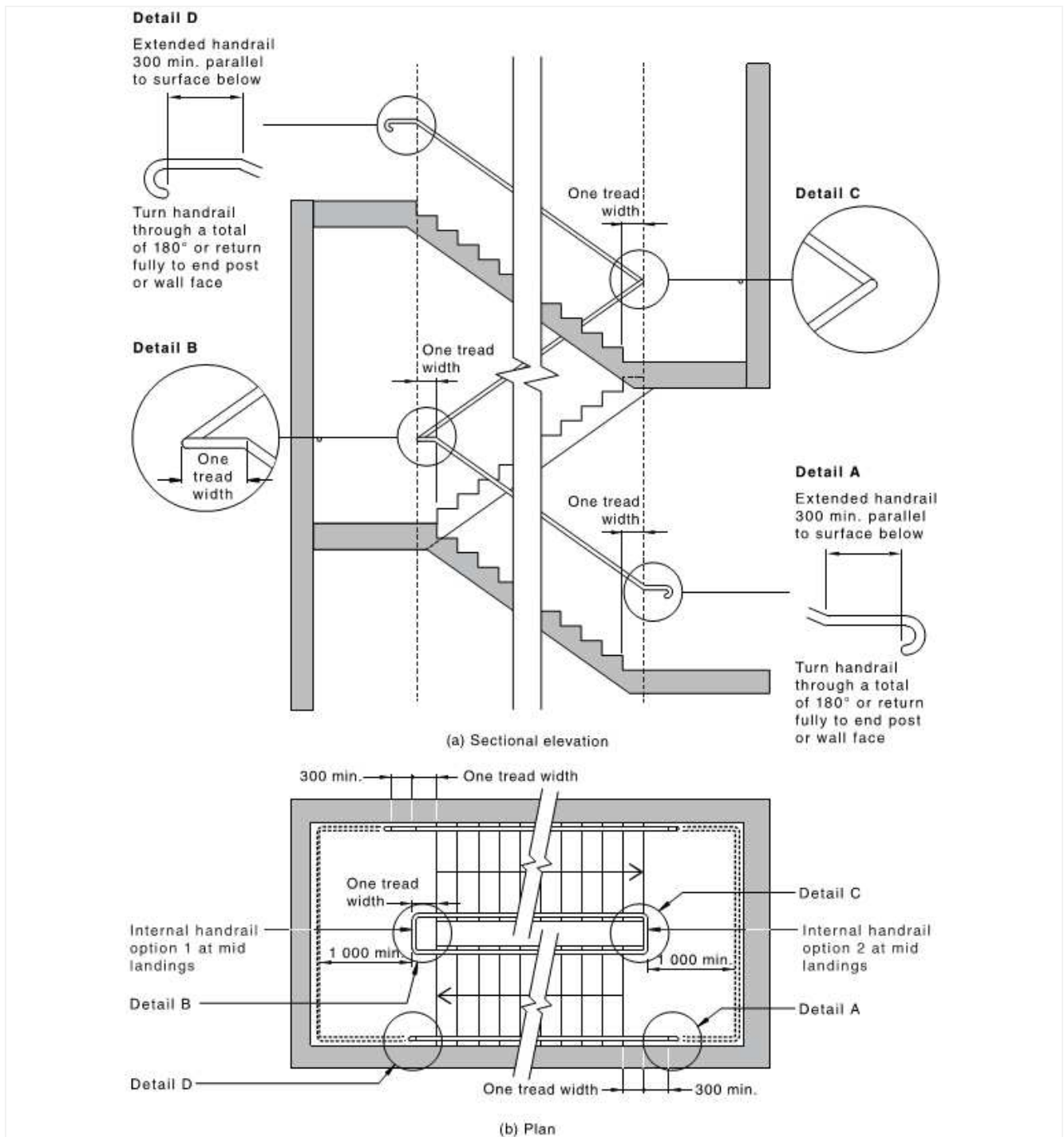

Figure 16

SAI Global Ltd License 1704-c045-2

(a) Handrails and balustrades shall not encroach into required circulation spaces.

(b) The cross-section of handrails shall be circular or elliptical, not less than 30 mm or greater than 50 mm in height or width for not less than 270° around the uppermost surface as shown in the Figures below. Elliptical handrails shall have the greater dimension in the horizontal axis as shown in Figure below.

(c) Exposed edges at ends and corners of handrails shall have a radius of not less than 5 mm.

(d) The top of handrails shall be not less than 865 mm nor more than 1000 mm above the nosing of stairway tread or the plane of the finished floor of the walkway, ramp or landing.

(e) The height of the top of the handrail, measured in accordance with Item (d), shall be consistent through the ramp (or stairs) and any landings.

- (f) If a balustrade is required at a height greater than the handrail, both shall be provided.
- (g) Handrails shall be securely fixed and rigid, and their ends shall be turned through a total of 180°, or to the ground, or returned fully to end post or wall face, as shown in Figures 14 and 15.
- (h) The clearance between a handrail and an adjacent wall surface or other obstruction shall be not less than 50 mm. This clearance shall extend above the top of the handrail by not less than 600 mm.
- (i) Handrails shall have no obstruction to the passage of a hand along the rail, as shown in below.
- (j) The inside handrail at landings shall always be continuous, as shown in Figure 16.

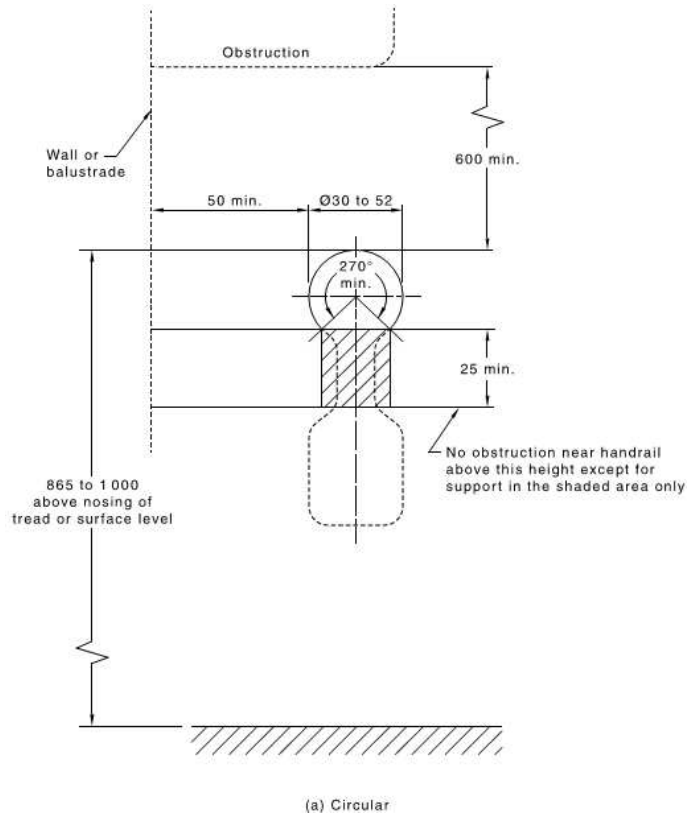

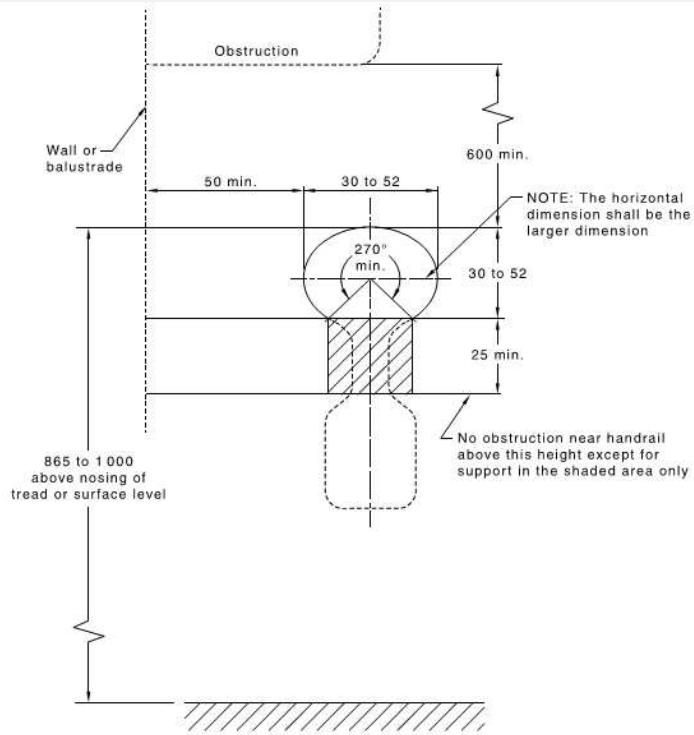

(b) Elliptical
Figure 17 SAI Global Ltd License 1704-c045-2

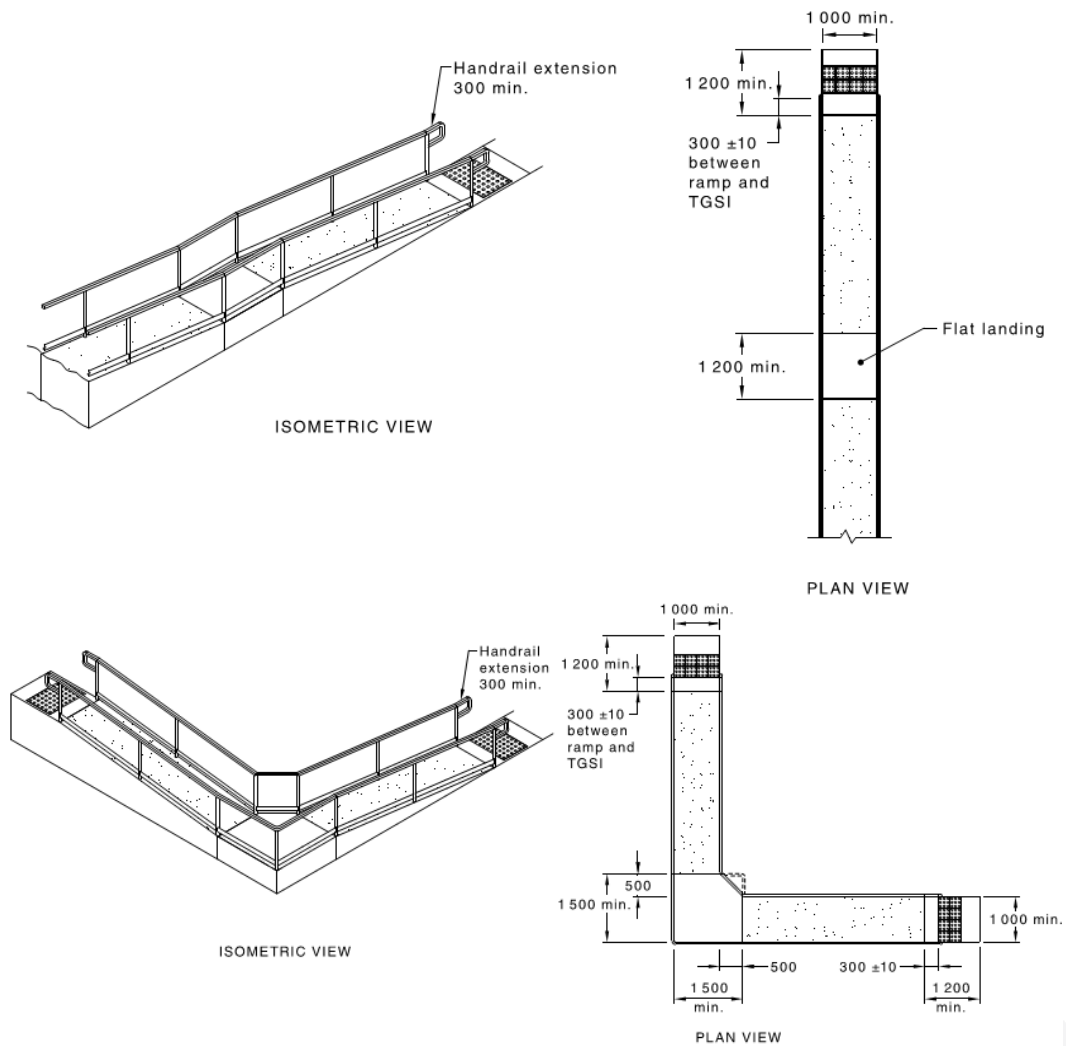

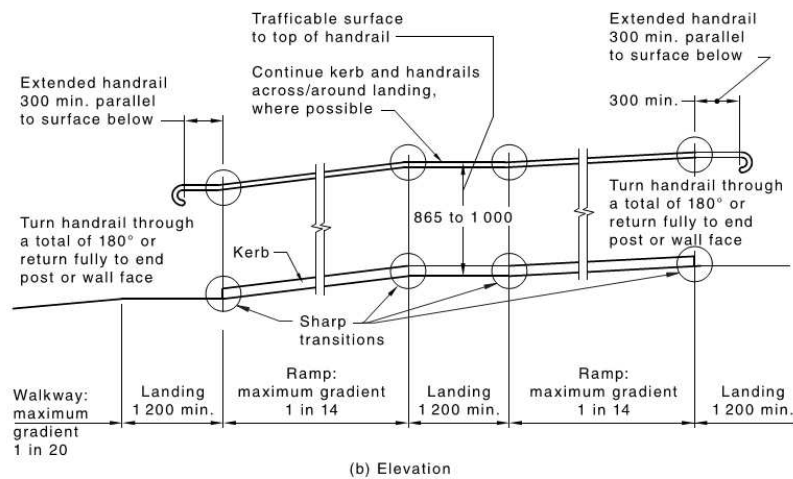
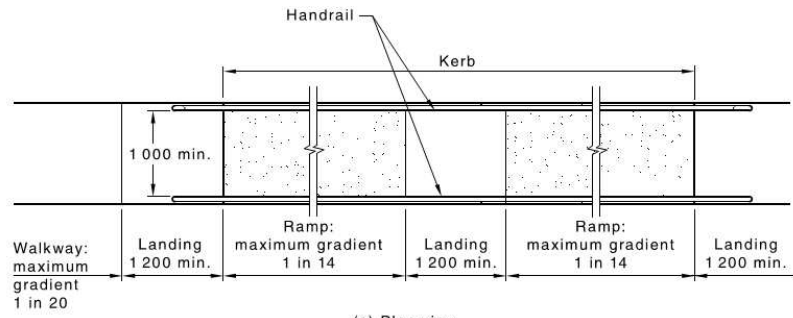
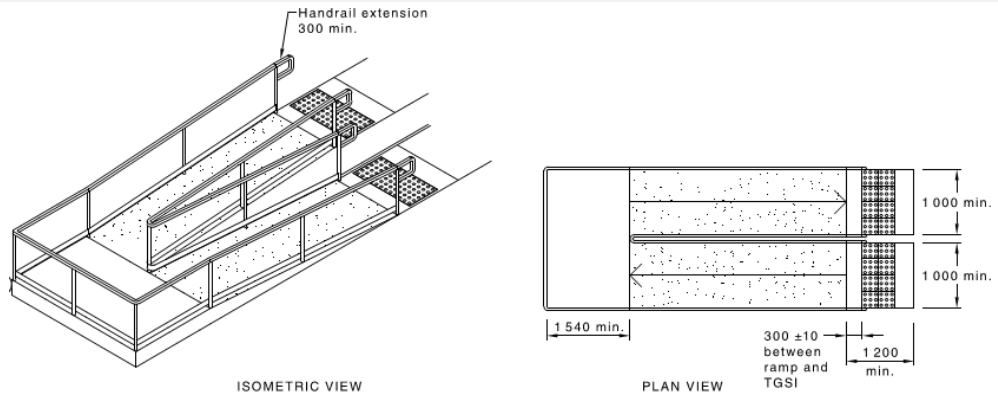

Figure 18

SAI Global Ltd License 1704-c045-2

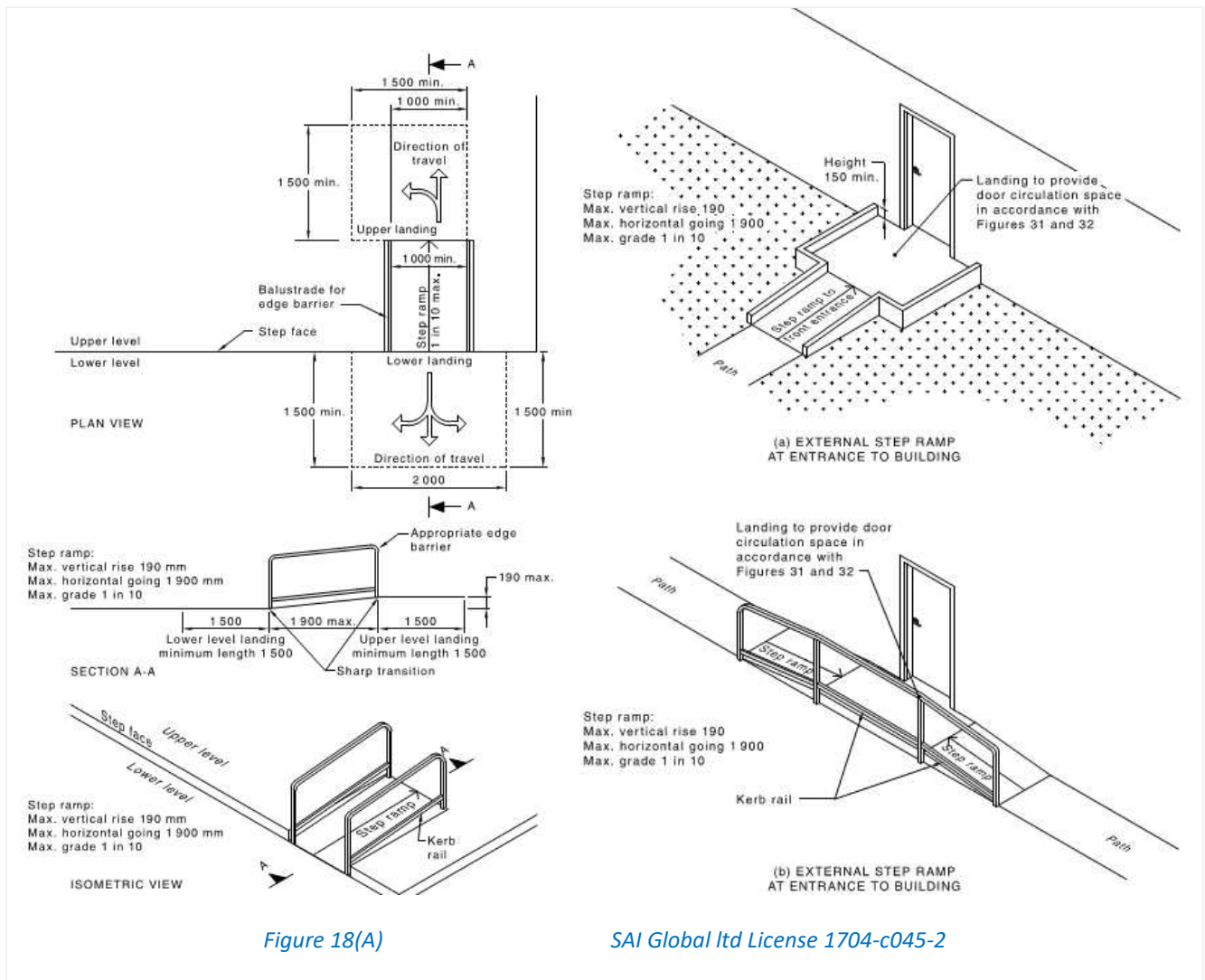

Figure 18(A)

SAI Global Ltd License 1704-c045-2

Walkways

Walkways shall be in accordance with the following:

- (a) The floor or ground surface abutting the sides of the walkway shall provide a firm and level surface of a different material to that of the walkway at the same level of the walkway, follow the grade of the walkway and extend horizontally for a minimum of 600 mm unless one of the following is provided:
 - (i) Kerb in accordance with the Figure “*kerb*” below; or
 - (ii) Kerb rail and handrail in accordance with the Figure “*kerb or kerb rail options*” below; or
 - (iii) A wall, fence, balustrade or similar barrier.

In the case of a street kerb, the minimum width of the walkway shall be increased by 600 mm at that side as shown in Figures “*attached kerb ramp*” and “*In line kerb ramps – Narrow footpath*”.

- (b) Walkways shall be provided with landings, as specified and listed below section “*Landings*”, at intervals not exceeding the following:
 - (i) For walkway gradients of 1 in 33, at intervals no greater than 25 m.
 - (ii) For walkway gradients of 1 in 20, at intervals no greater than 15 m.
 - (iii) For walkway gradients between 1 in 20 to 1 in 33, at intervals that shall be obtained by linear interpolation.

For walkways shallower than 1 in 33, no landings are required.

The intervals specified above may be increased by 30 % where at least one side of a walkway is bounded by —

- (iv) a kerb or kerb rail as specified in point (1) below and a handrail as specified in Figure 17; **or**
- 1- Where a handrail is not supported on a wall, ramps and intermediate landings shall have kerbs or kerb rails in accordance with the following:
 - (i) The minimum height above the finished floor shall be 65 mm.
 - (ii) The height of the top of the kerb or kerb rail shall not be within the range 75 mm to 150 mm above the finished floor, as shown in Figure 18.
 - (iii) There shall be no longitudinal gap or slot greater than 20 mm in the kerb or kerb rail within the range 75 mm to 150 mm above the finished floor.

NOTE 2 For details on kerbs and kerb rails, see the Figure below “*kerb*”.

NOTE 3 For location of kerb or kerb rail, see the Figure below “*kerb or kerb rail options*”.

- (v) a wall and a handrail as specified in Figure 17.

Landings

1. Walkways and ramps

The length of landings at walkways and ramps shall be in accordance with one of the following:

- (a) Where there is no change in direction, the length shall be not less than 1200 mm, as shown in Figure 18.
- (b) Where there is a change of direction not exceeding 90°, the landing shall be not less than 1500 mm long and 1500 mm wide. The internal corner may be truncated as shown in Figure 18. Where it is truncated, the truncation shall not reduce the clear width of the accessways.
- (c) For a 180° turn, the landing shall be as shown in Figure 18.

2. Step ramps

The length of landings at step ramps shall be not less than 1200 mm in the direction of travel, as shown in Figures 18(A) and 18(A).

Where a change in direction is required, the length of step ramp landings shall be a minimum of 1500 mm, as shown in Figure 18(A).

Where doorways are at landings, the dimensions of the landings shall be in accordance with the circulation spaces at doorways as shown in Figures 29 and 29(A).

3. Kerb ramps

The length of landings at kerb ramps shall be not less than 1200 mm in the direction of travel.

Where a “T” junction occurs, the kerb ramp landing shall be a minimum of 1500 mm × 2000 mm, as shown in the Figure below “*attached kerb ramp*”

Where a single change in direction is required, the ramp landings shall be a minimum of 1500 mm × 1500 mm.

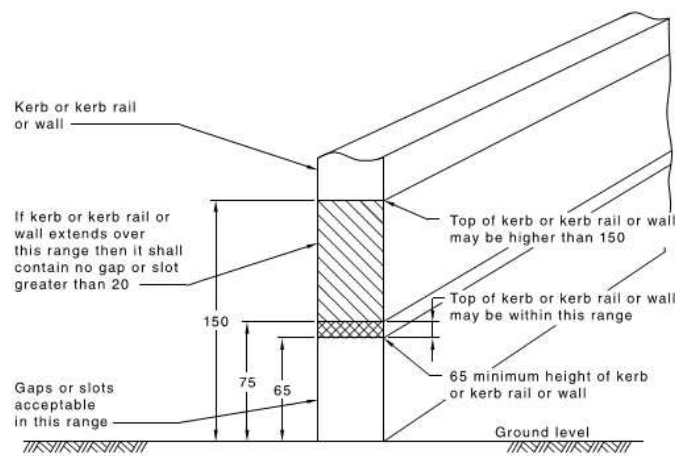

Kerb

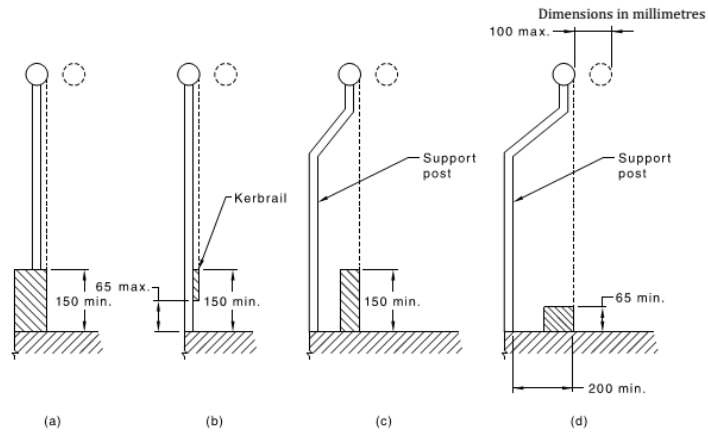

Selection showing the location of the kerb or kerb rail in relation to the handrail with vertical support

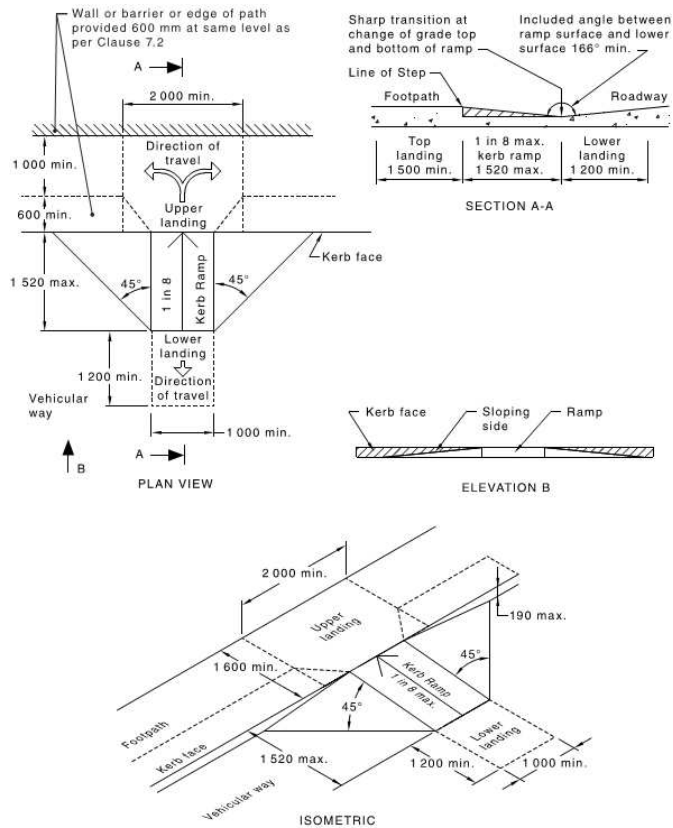

Attached kerb ramp

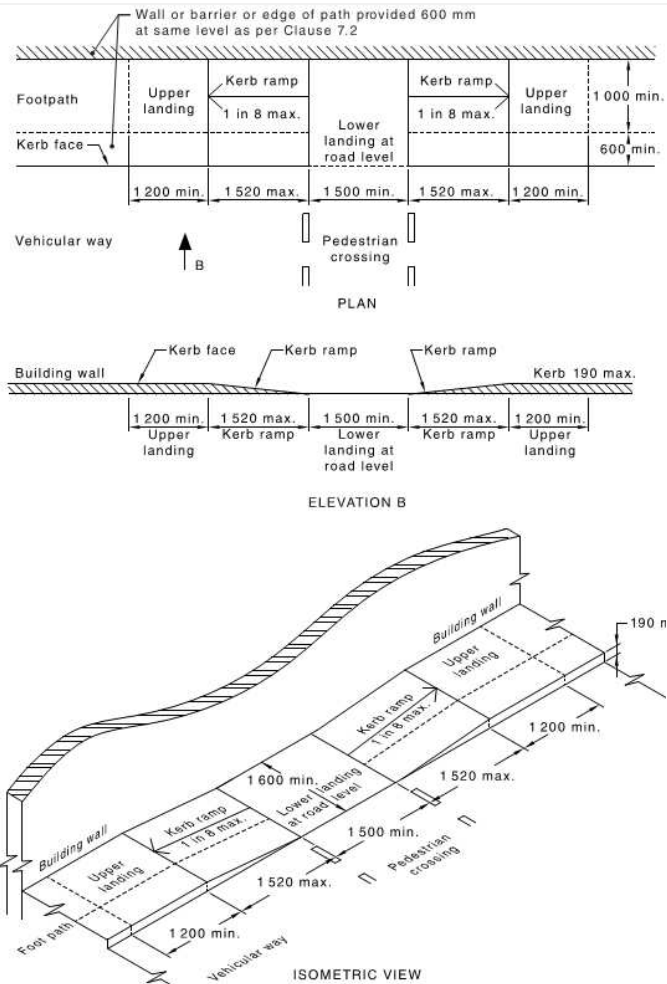

In line kerb ramps – Narrow footpath

Figure 19

SAI Global Ltd License 1704-c045-2

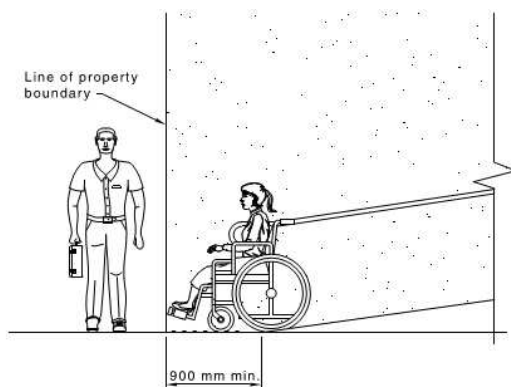

Figure 20 SAI Global Ltd License 1704-c045-2

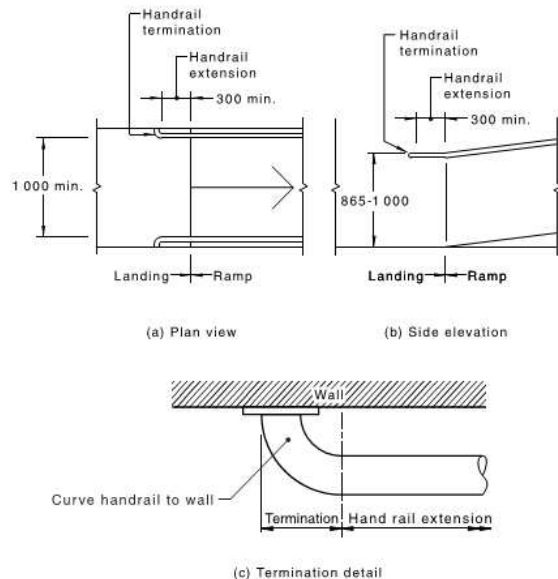

Figure 21

SAI Global Ltd License 1704-c045-2

Visual indicators on glazing

Where there is no chair rail, handrail or transom, all frameless or fully glazed doors, sidelights, including any glazing capable of being mistaken for a doorway or opening, shall be clearly marked for their full width with an unbroken, solid and opaque contrasting line. The contrasting line shall be not less than 75 mm high and shall extend across the full width of the glazing panel. The lower edge of the contrasting line shall be located between 900 mm and 1 000 mm above the plane of the finished floor level.

Any contrasting line on the glazing shall provide a minimum of 30 % luminance contrast when viewed against the floor surface or surfaces within 2 m of the glazing on the opposite side. The contrast shall be achieved when viewed from each side of the glazing.

The opacity of the line shall be tested by observing a solid object placed immediately behind and touching the glass. The line shall be considered opaque if there is no image of the object visible.

NOTE 1 On tinted glass, the contrast of the strip may be more appropriately considered against the glass tint than the floor beyond.

NOTE 2 Any logo, branding, company name or the like may be added to the visual indicator strip, but these should be fully above, or fully below the minimum 75 mm wide unbroken, solid and opaque contrasting line.

NOTE 3 AS 1288:2006 Section 5 provides further information relating to the criteria and situations relevant to glazing that is more vulnerable to human impact.

Figure 22

SAI Global Ltd License 1704-c045-2



Figure 23

SAI Global Ltd License 1704-c045-2



Figure 24

SAI Global Ltd License 1704-c045-2

3. Braille and tactile sign specification

- (a) Tactile characters must be raised or embossed to a height of not less than 1 mm and not more than 1.5 mm.
- (b) Sentence case (upper case for the first letter of each main word and lower case for all other letters) must be used for all tactile characters, and—
 - (i) upper case tactile characters must have a height of not less than 15 mm and not more than 55 mm, except that the upper case tactile characters on a sign identifying a door *required* by E4.5 to be provided with an *exit* sign must have a height of not less than 20 mm and not more than 55 mm; and
 - (ii) lower case tactile characters must have a height of 50% of the related upper case characters.
- (c) Tactile characters, symbols, and the like, must have rounded edges.
- (d) The entire sign, including any frame, must have all edges rounded.
- (e) The background, negative space or fill of signs must be of matt or low sheen finish.
- (f) The characters, symbols, logos and other features on signs must be matt or low sheen finish.
- (g) The minimum letter spacing of tactile characters on signs must be 2 mm.
- (h) The minimum word spacing of tactile characters on signs must be 10 mm.
- (i) The thickness of letter strokes must be not less than 2 mm and not more than 7 mm.
- (j) Tactile text must be left justified, except that single words may be centre justified.
- (k) Tactile text must be Arial typeface.

4. Luminance contrast

The following applies to *luminance contrast*.

- (a) The background, negative space, fill of a sign or border with a minimum width of 5 mm must have a *luminance contrast* with the surface on which it is mounted of not less than 30%.
- (b) Tactile characters, icons and symbols must have a minimum *luminance contrast* of 30% to the surface on which the characters are mounted.
- (c) *Luminance contrasts* must be met under the lighting conditions in which the sign is to be located.

Figure 25

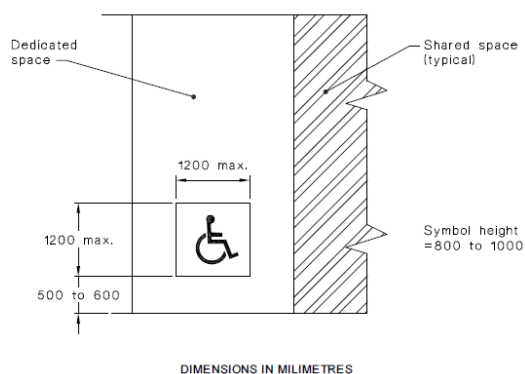

Figure 26 SAI Global Ltd License 1704-c045-2

SAI Global Ltd License 1704-c045-2

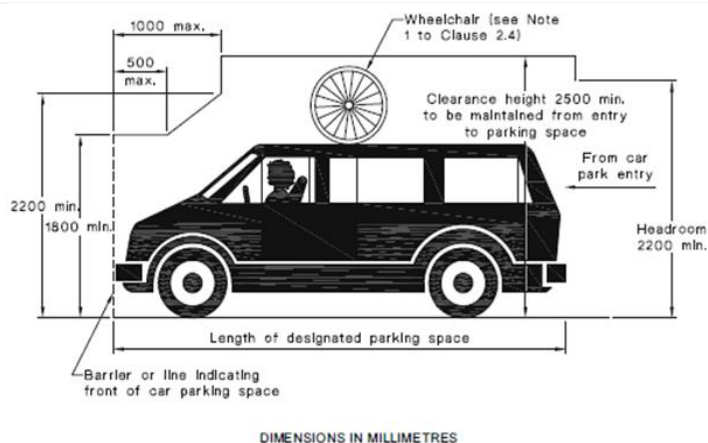

Figure 27

SAI Global Ltd License 1704-c045-2

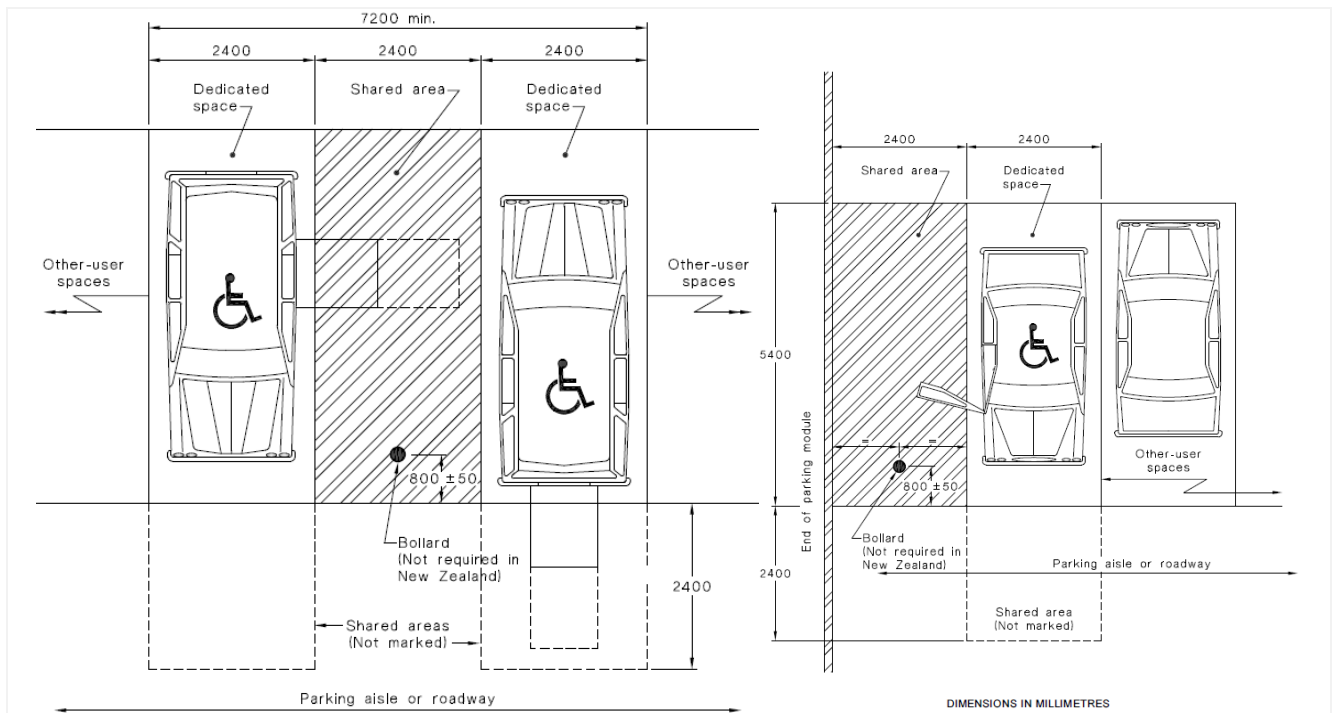
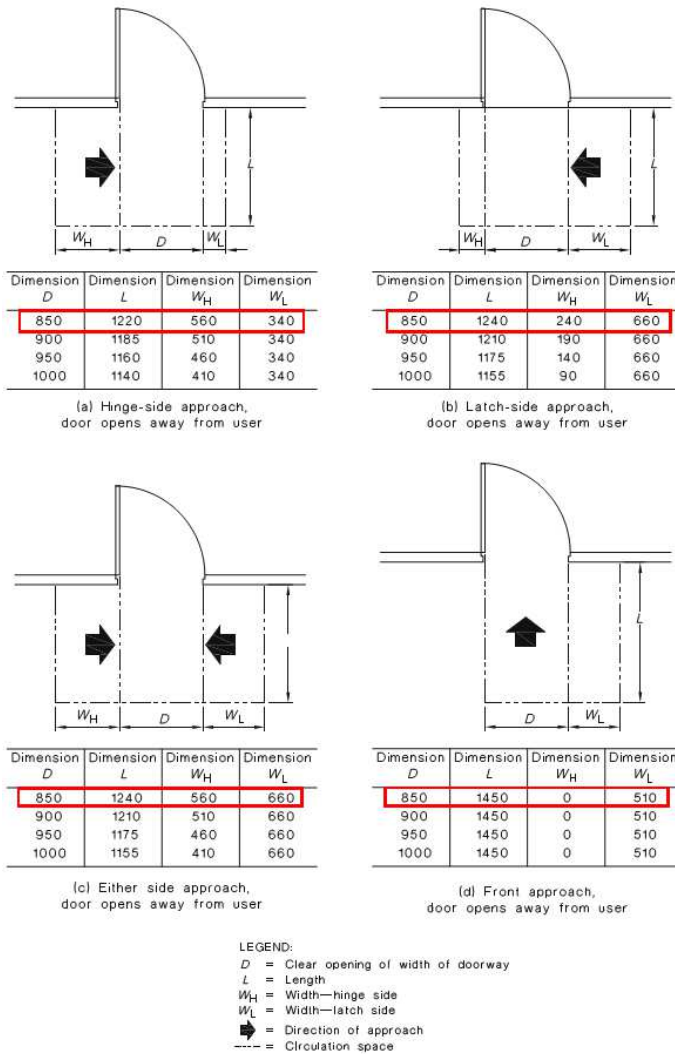
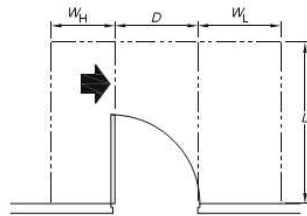

Figure 28

SAI Global Ltd License 1704-c045-2





Dimension D	Dimension L	Dimension W _H	Dimension W _L
850	1670	660	900
900	1670	610	900
950	1670	560	900
1000	1670	510	900

(e) Hinge-side approach, door opens towards user

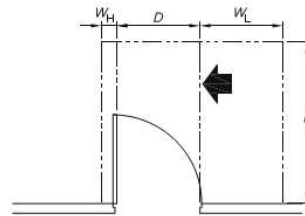

Dimension D	Dimension L	Dimension W _H	Dimension W _L
850	1670	110	900
900	1670	110	900
950	1670	110	900
1000	1670	110	900

(f) Latch-side approach, door opens towards user

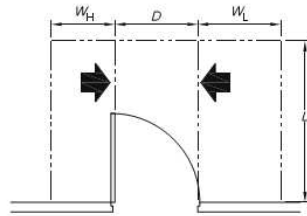

Dimension D	Dimension L	Dimension W _H	Dimension W _L
850	1670	660	900
900	1670	610	900
950	1670	560	900
1000	1670	510	900

(g) Either side approach, door opens towards user

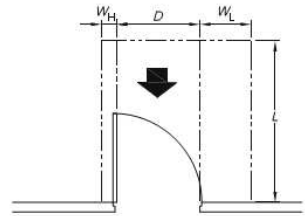

Dimension D	Dimension L	Dimension W _H	Dimension W _L
850	1450	110	530
900	1450	110	530
950	1450	110	530
1000	1450	110	530

(h) Front approach, door opens towards user

LEGEND:
 D = Clear opening of width of doorway
 L = Length
 W_H = Width—hinge side
 W_L = Width—latch side
 → = Direction of approach
 --- = Circulation space

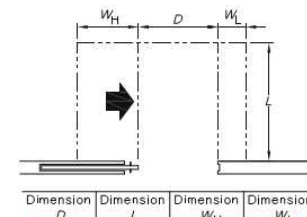

Dimension D	Dimension L	Dimension W _H	Dimension W _L
850	1280	660	395
900	1280	610	395
950	1280	560	395
1000	1280	510	395

(a) Slide-side approach

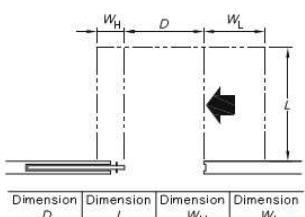

Dimension D	Dimension L	Dimension W _H	Dimension W _L
850	1230	185	660
900	1230	180	660
950	1230	180	660
1000	1230	180	660

(b) Latch-side approach

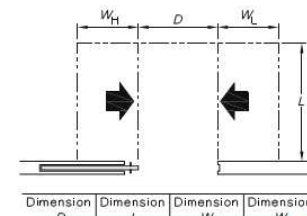

Dimension D	Dimension L	Dimension W _H	Dimension W _L
850	1280	660	660
900	1280	610	660
950	1280	560	660
1000	1280	510	660

(c) Either side approach

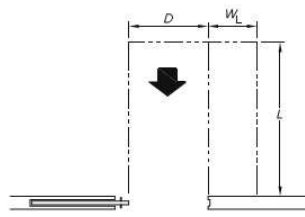

Dimension D	Dimension L	Dimension W _H	Dimension W _L
850	1450	0	530
900	1450	0	530
950	1450	0	530
1000	1450	0	530

(d) Front approach

LEGEND:
 D = Clear opening of width of doorway
 L = Length
 W_H = Width—hinge side
 W_L = Width—latch side
 → = Direction of approach
 --- = Circulation space

Figure 29

SAI Global Ltd License 1704-c045-2

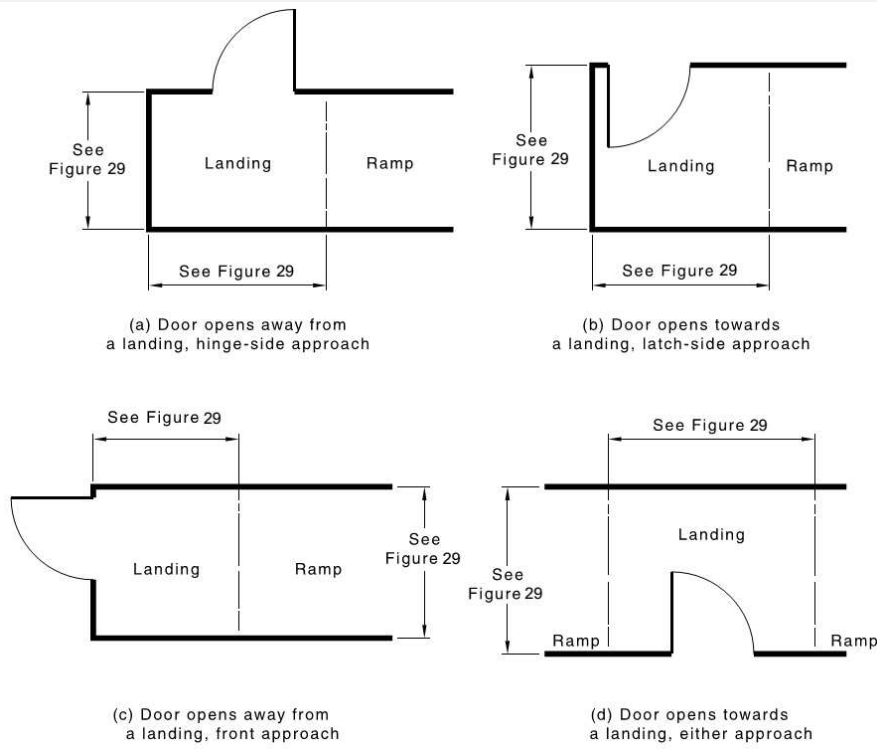

Figure 29(A)

SAI Global Ltd License 1704-c045-2

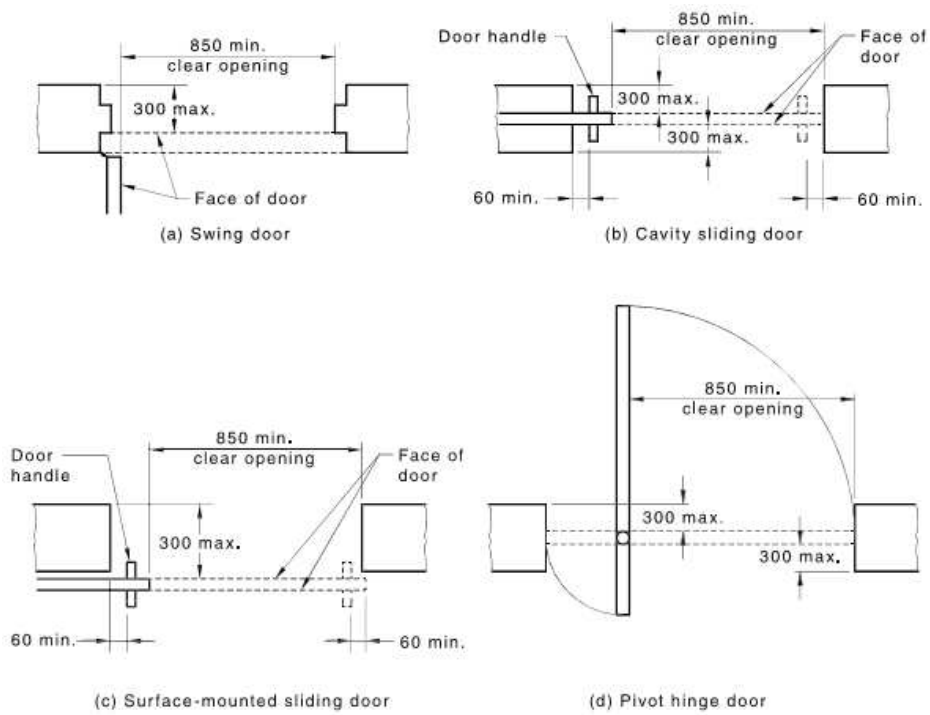

Figure 29(B)

SAI Global Ltd License 1704-c045-2

Part D4 – Attachments

The attachments below are extracted from the Architectural Plans provided and are to be read as set and referenced in each section of part D4



Basement 02



Basement 01



Lower Ground Floor

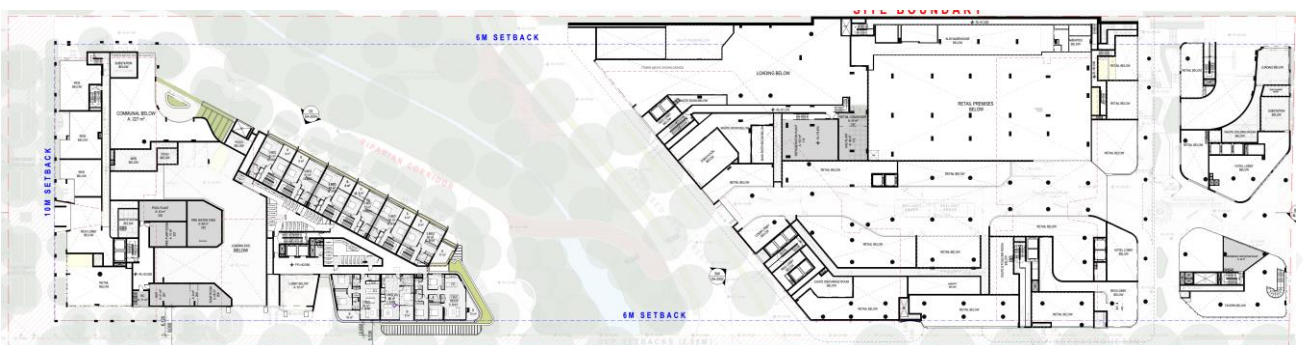

Mezzanine Floor



Ground Floor

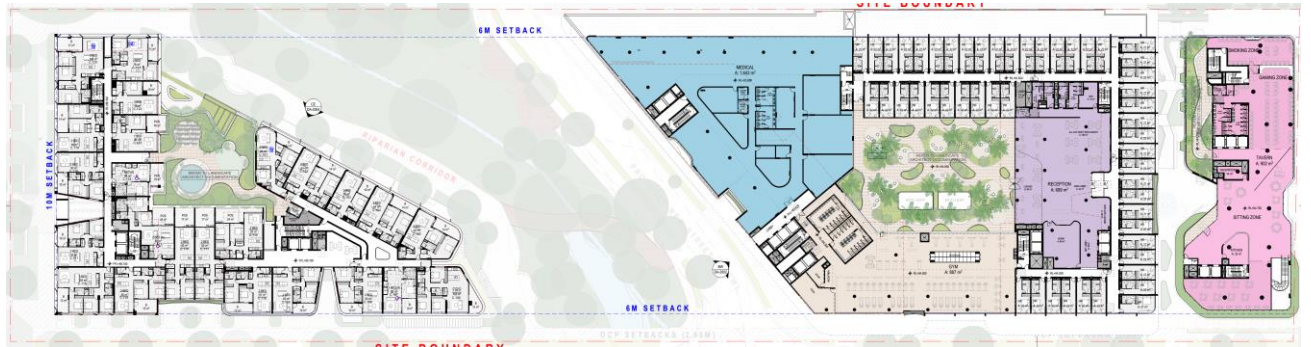

Level 01

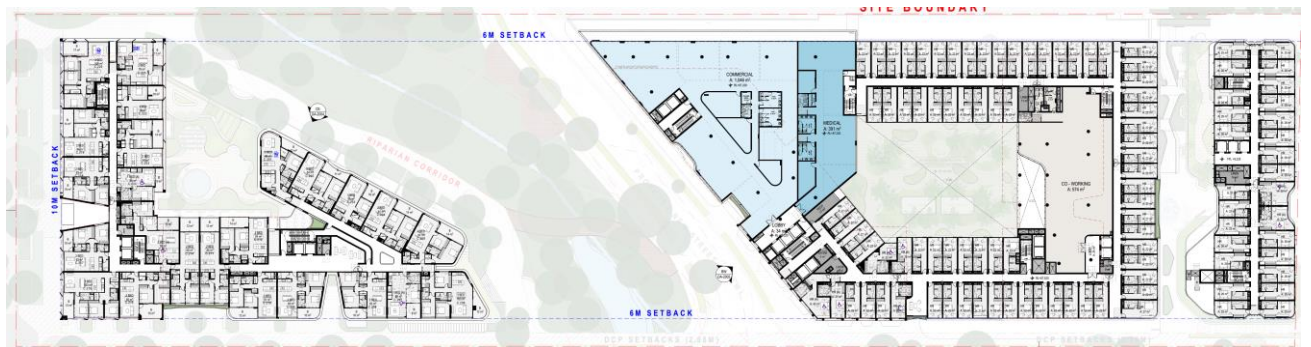

Level 02



Level 03



Level 04

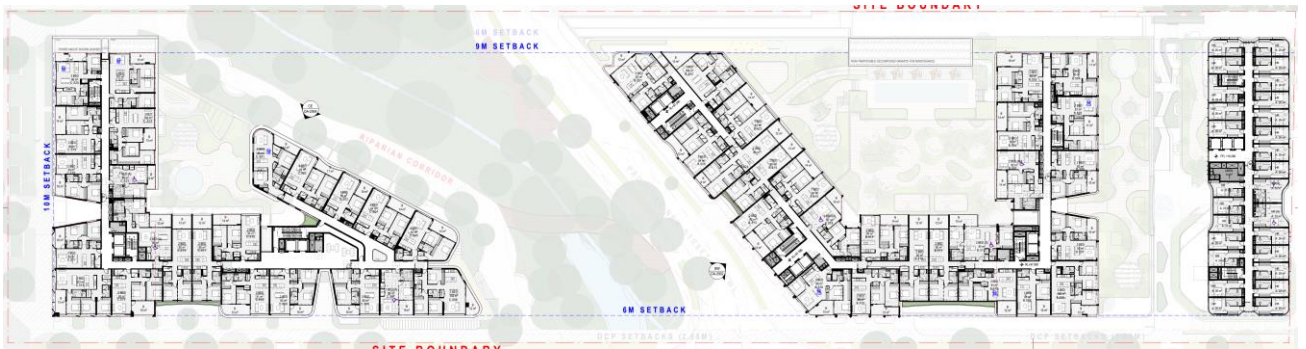

Levels 05-08

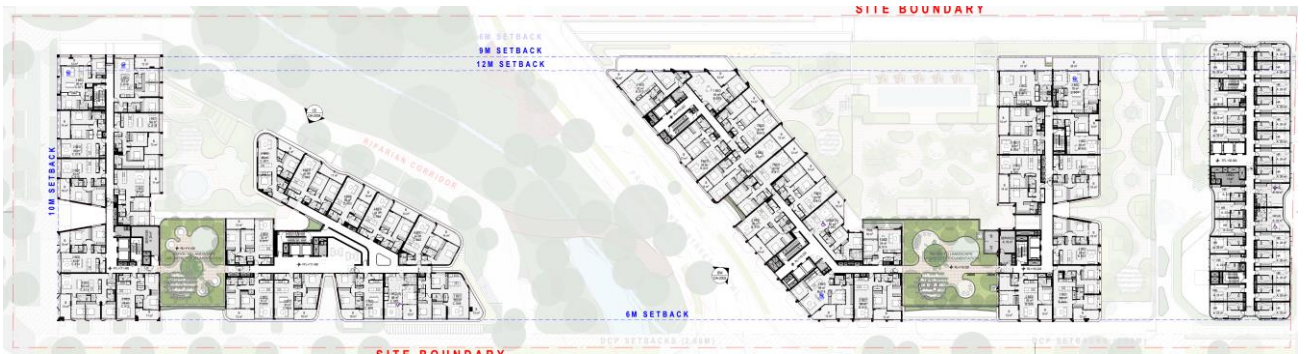

Level 09

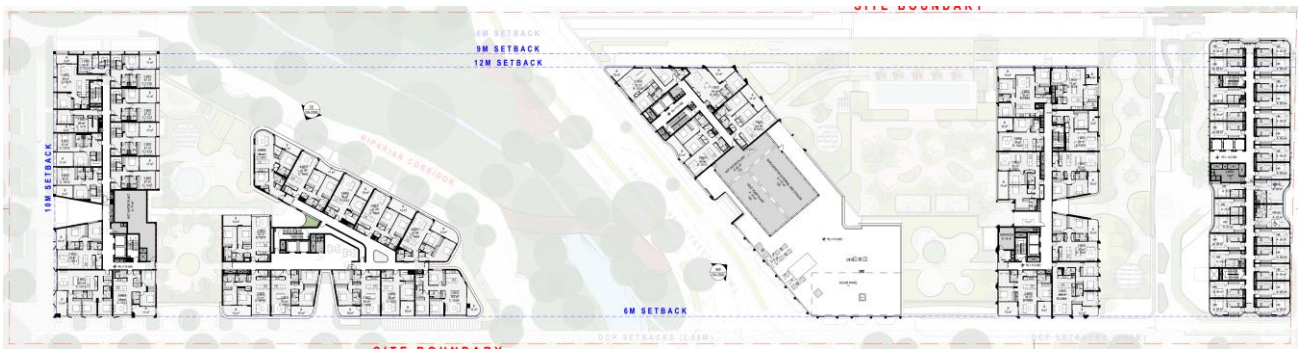

Level 10

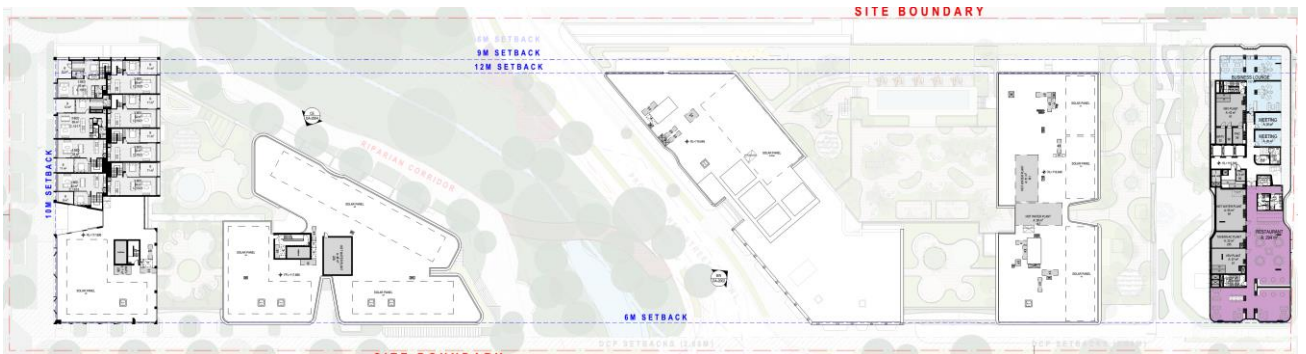

Level 11

Att. 01 Floor Plans prepared by "PLUS STUDIO" Issue No. A dated 01/10/2025

AS 1428.1 – Additional Requirements

The additional requirements set below to be read in full	ADR	N/A	C
<p>1. Access ways:</p> <ul style="list-style-type: none"> All access ways must have a minimum width of 1m clear and a vertical clearance of at least 2m. <p>Reference: Figure 30 Notes: See Att. 01 – can be compliant at the CC stage</p>	<input type="checkbox"/>	<input type="checkbox"/>	✓
<p>2. Doorway general requirements:</p> <ul style="list-style-type: none"> All doorways are to be in accordance with AS1428.1. Reference: Figure 29, Figure 29(A), Figure 29(B) Door thresholds are to be level or they can incorporate a threshold ramp as per AS1428.1 Reference: Figure 32 Distance between successive doorways in airlocks to be 1450mm which is measured when the door is in an open position in case of swinging doors Reference: Figure 31 Glazed viewing panels in doors shall conform to AS 1288. <ul style="list-style-type: none"> The lower edge of the glazing should not be more than 1000 mm above the plane of the finished floor. The upper edge of the glazing should be not less than 1600 mm above the plane of the finished floor. In width, the glazing should extend to within not more than 200 mm from the latch edge of the door and be not less than 150 mm wide. Reference: Figure 38 <p>Notes: See Att. 01 – can be compliant at the CC stage</p>	<input type="checkbox"/> <input type="checkbox"/> <input type="checkbox"/>	<input type="checkbox"/> <input type="checkbox"/> <input type="checkbox"/>	✓ ✓ ✓
<p>3. Door hardware:</p> <ul style="list-style-type: none"> Door hardware including door handles, door closers, snibs (in accessible toilets) are required to be as per the requirements in AS1428.1 <p>Reference: Figure 33 Notes: See Att. 01 – can be compliant at the CC stage</p>	<input type="checkbox"/>	<input type="checkbox"/>	✓
<p>4. Luminance contrast requirements for Doors:</p> <ul style="list-style-type: none"> All doorways are to have a minimum luminance contrast of 30% and a minimum width of 50mm provided as per AS1428.1 between any option of the following options: <ul style="list-style-type: none"> Door leaf and door jamb – min. 50mm or; Architrave “min. 50mm” and wall or; Door leaf and architrave – min. 50mm or; Door jamb “min. 50mm” and adjacent wall or; Door leaf and adjacent wall <p>Notes: See Att. 01 – can be compliant at the CC stage</p>	<input type="checkbox"/>	<input type="checkbox"/>	✓

<p>5. Floor Surfaces:</p> <ul style="list-style-type: none"> • Use slip resistant surfaces. The texture of the surface shall be traversable by people who use a wheelchair and those with an ambulant or sensory disability. <ul style="list-style-type: none"> - Refer to • Abutment of surfaces shall have a smooth transition. Construction specifications are to be as per AS1428.1. Reference: Figure 34, Figure 35 • Any grates along the path must be as per AS1428.1 Reference: Figure 36 <p>Notes: See Att. 01 – can be compliant at the CC stage</p>	<input type="checkbox"/>	<input type="checkbox"/>	<input checked="" type="checkbox"/>
<p>6. Switches and Outlets:</p> <ul style="list-style-type: none"> • All switches and controls on an accessible path of travel, other than general purpose outlets, shall be located not less than 900 mm nor more than 1100 mm above the plane of the finished floor and not less than 500 mm from internal corners. • GPOs are to be located between 600-1100mm above FFL and a minimum of 500mm from any internal corners. • Rocker action/toggle switches to be provided with a minimum size of 30mmx30mm • Push pad switches if used have a minimum dimension of 25mm diameter • All switches in accessible sole occupancy units or sanitary facilities are to be located as per AS1428.1 <p>Reference: Figure 37 Notes: See Att. 01 – can be compliant at the CC stage</p>	<input type="checkbox"/>	<input type="checkbox"/>	<input checked="" type="checkbox"/>



Additional Requirements – References

The references below to be read as set and referenced in each section of Additional Requirements

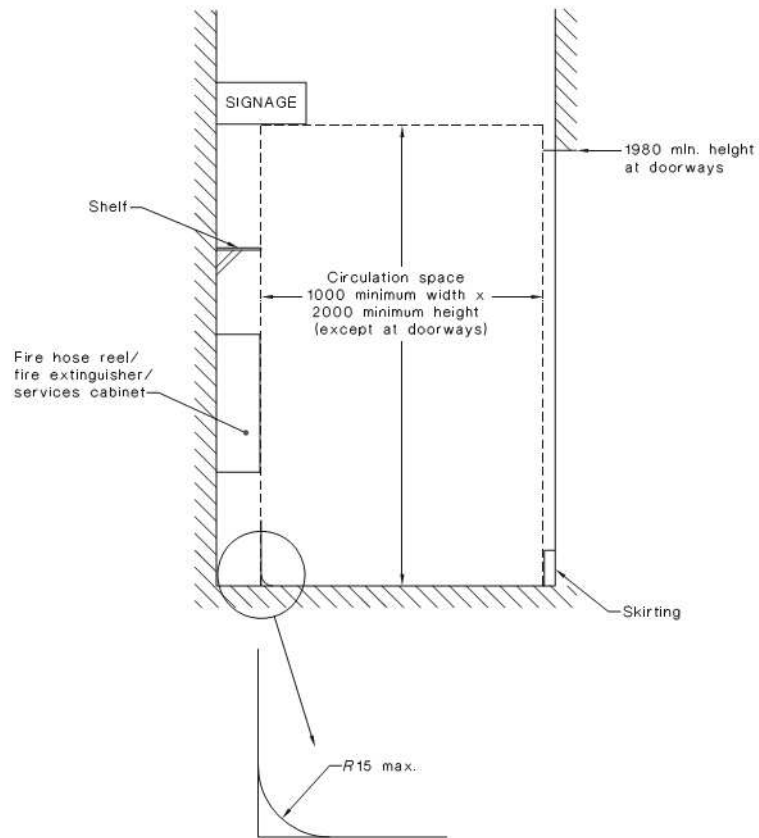
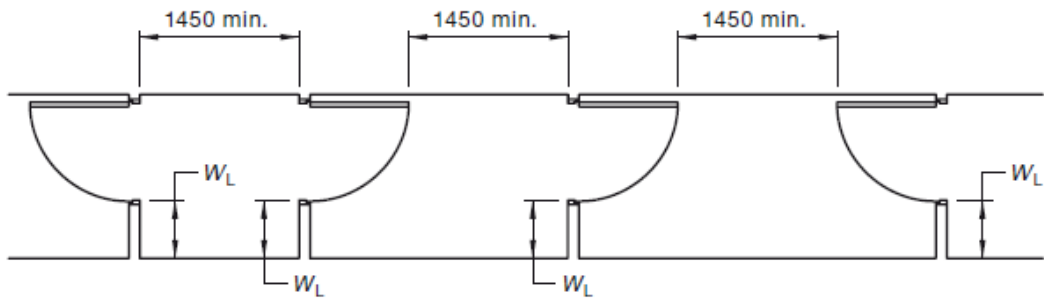

Figure 30

SAI Global Ltd License 1704-c045-2



(a) Continuous accessible path of travel

DIMENSIONS IN MILLIMETRES

Figure 31

SAI Global Ltd License 1704-c045-2

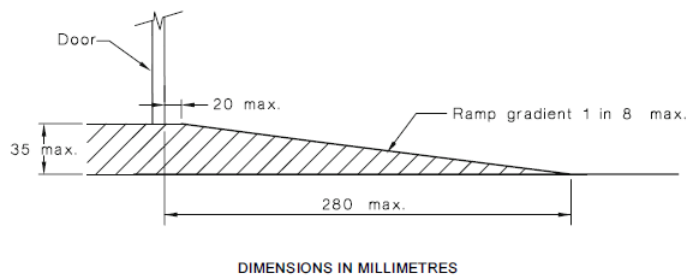

DIMENSIONS IN MILLIMETRES

Figure 32

SAI Global Ltd License 1704-c045-2

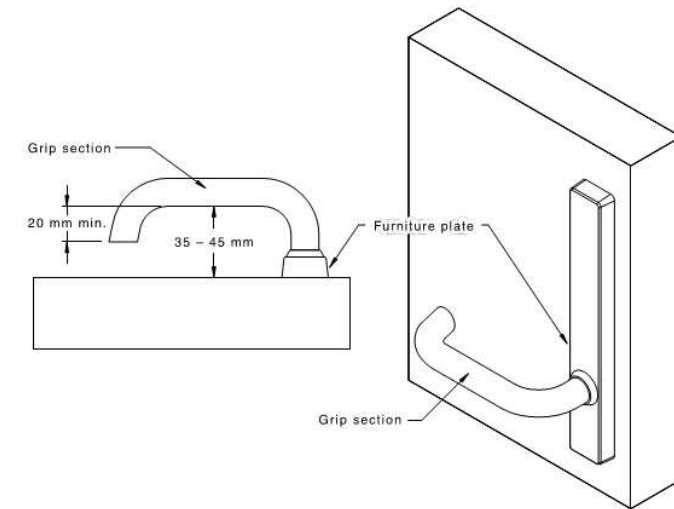
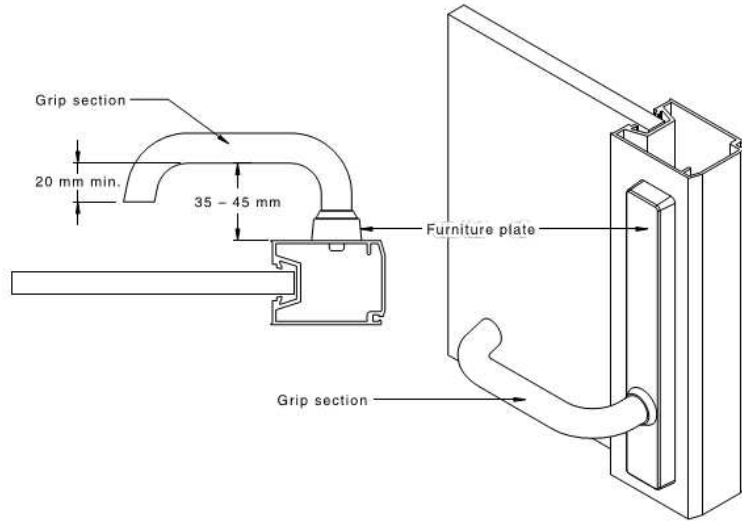
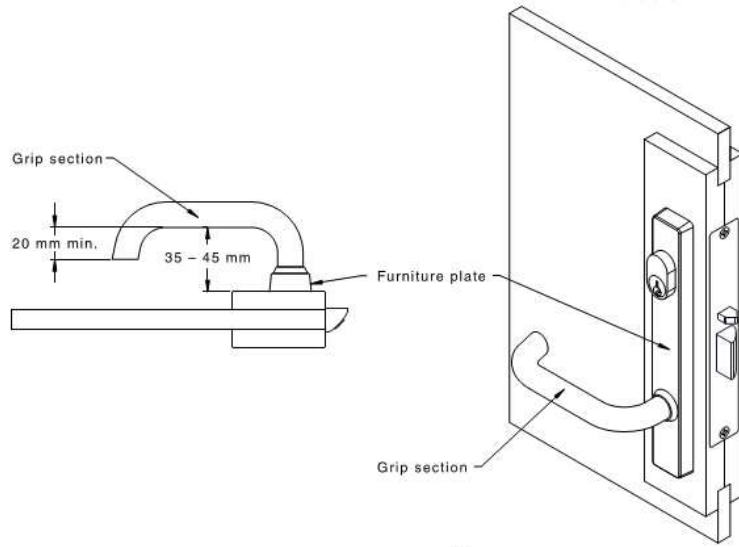

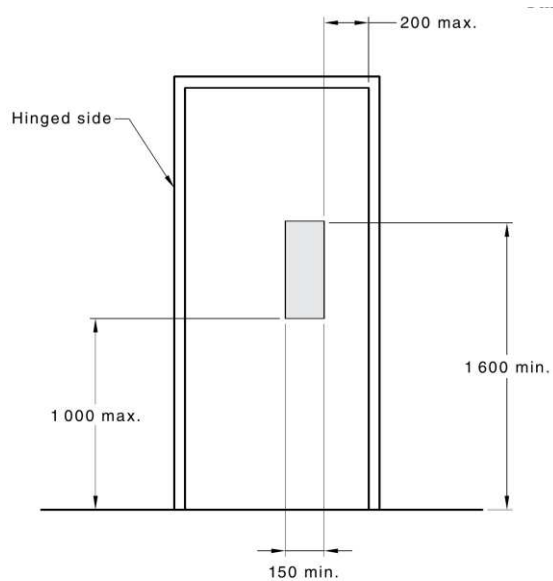
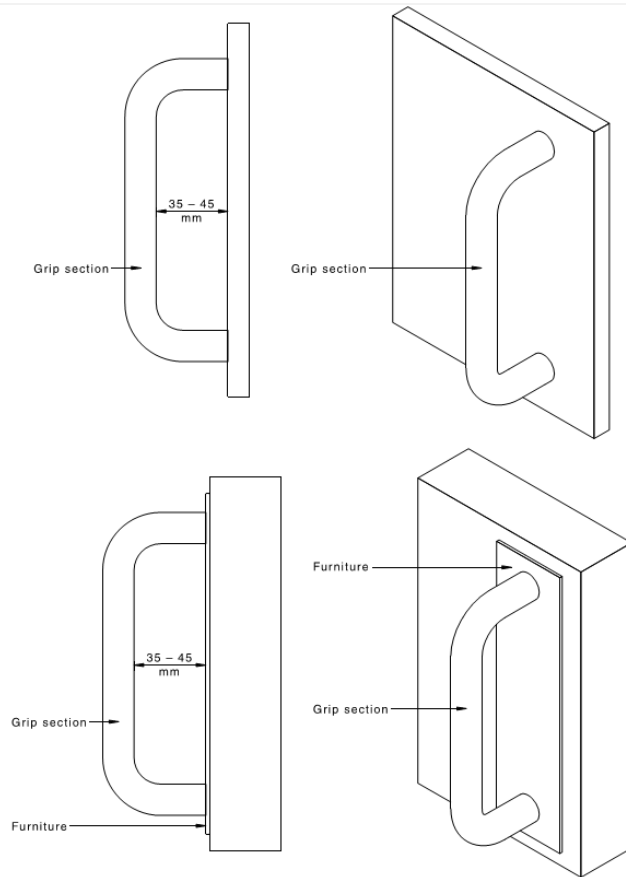

(a) Minimum zones for glazed viewing panel

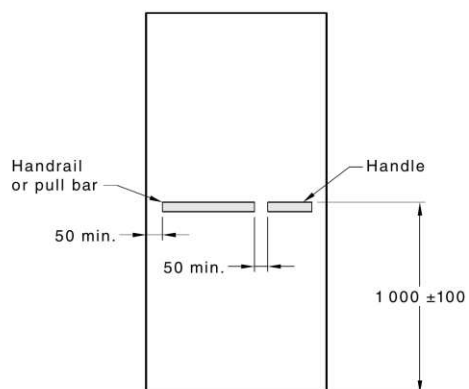

Location

Except in early childhood centres, swimming pool barriers or similar situations where the location of the opening and locking controls is prescribed by the relevant statutory authority, the location of the controls for doors and gates shall be above a level surface and as follows:

- (a)** Controls that need to be grasped or turned or pushed or pulled to operate a door shall be not less than 900 mm and not more than 1100 mm above the plane of the finished floor, as shown in the Figure above and not less than 500 mm from an internal corner except as specified in AS 1735.12.
- (b)** Controls that only need to be pushed in the direction of travel, such as panic bars on egress routes, shall be not less than 900 mm, and not greater than 1200 mm above the plane of the finished floor.
- (c)** Controls that only need to be touched shall be not less than 900 mm, and not greater than 1250 mm above the plane of the finished floor, and not less than 500 mm from an internal corner except as specified in AS 1735.12.
- (d)** Handles on sliding doors shall be not less than 60 mm from the door jamb or doorstop when in the open or closed position, as shown in Figure 29(B).
- (e)** Manual controls to power-operated doors shall be located on the continuous accessible path of travel no closer than 500 mm from an internal corner and between 500 mm to 1 000 mm from the arc of the hinged door leaf or clear of a surface-mounted sliding door in the open position.

Figure 33

SAI Global Ltd License 1704-c045-2

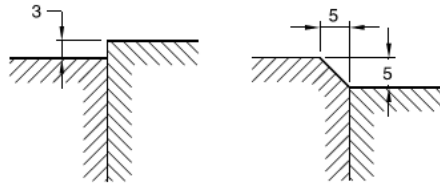

(a) Change in level

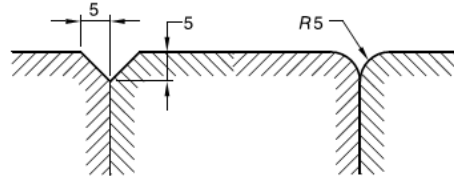

Continuous paving units — flush-jointed with level surfaces

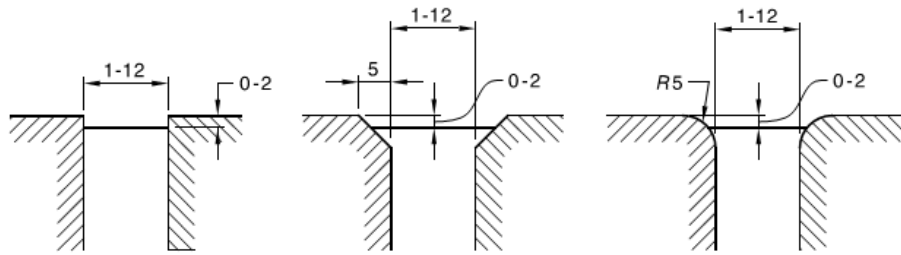

(a) Continuous paving units — Level surface

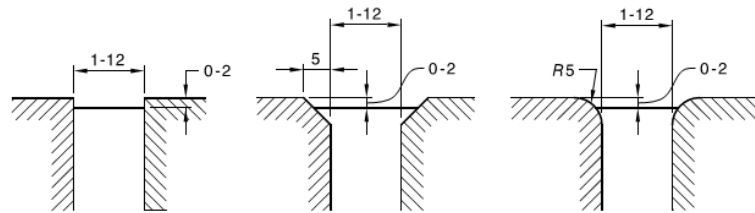

(a) Continuous paving units — Level surface

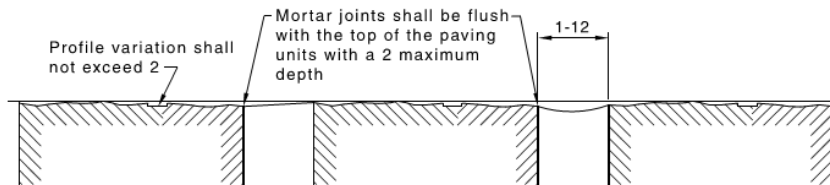

(b) Continuous paving units — Irregular surfaces

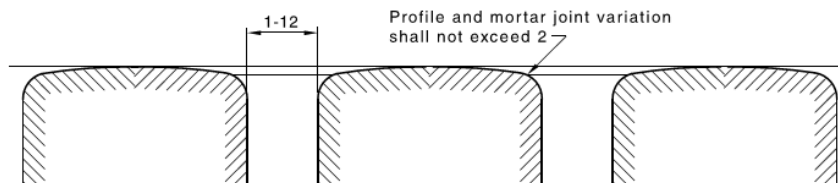

(c) Continuous paving units — Domed surfaces

Figure 34

SAI Global Ltd License 1704-c045-2

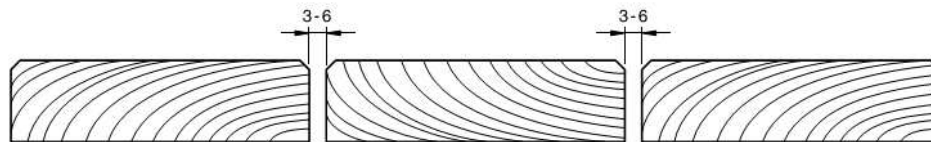

(a) Gap spacing for continuous timber and composite decking
 * Gaps may be increased to 10 mm in high rainfall areas for exposed installations and boards exceeding 150 mm width

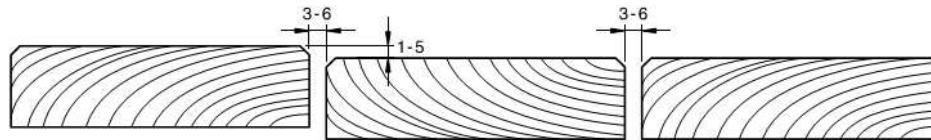

(b) Single incidence of change in level on timber and composite decking

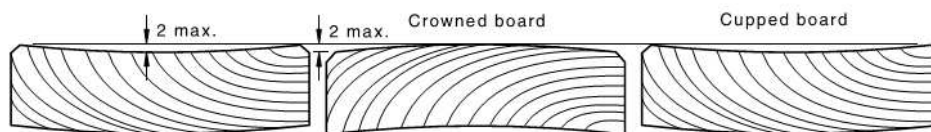

(c) Uneven surface tolerances for continuous timber and composite decking

Figure 35

SAI Global Ltd License 1704-c045-2

Grates

Grates in paths of travel shall be in accordance with the following:

- (a) Circular openings shall be not greater than 13 mm in diameter.
- (b) Slotted openings shall be not greater than 13 mm wide and not greater than 150 mm long and be oriented so that the long dimension is transverse to the dominant direction of travel.
- (c) Linear openings shall be oriented so that the longer dimension is transverse to the dominant direction of travel, except where linear openings are less than 8 mm wide, Where linear openings are less than 8 mm wide, orientation is optional.

Figure 36

SAI Global Ltd License 1704-c045-2

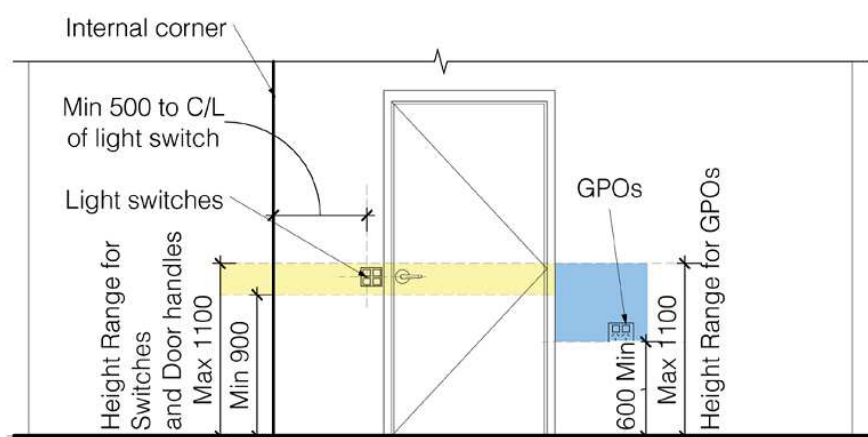

Figure 37

SAI Global Ltd License 1704-c045-2

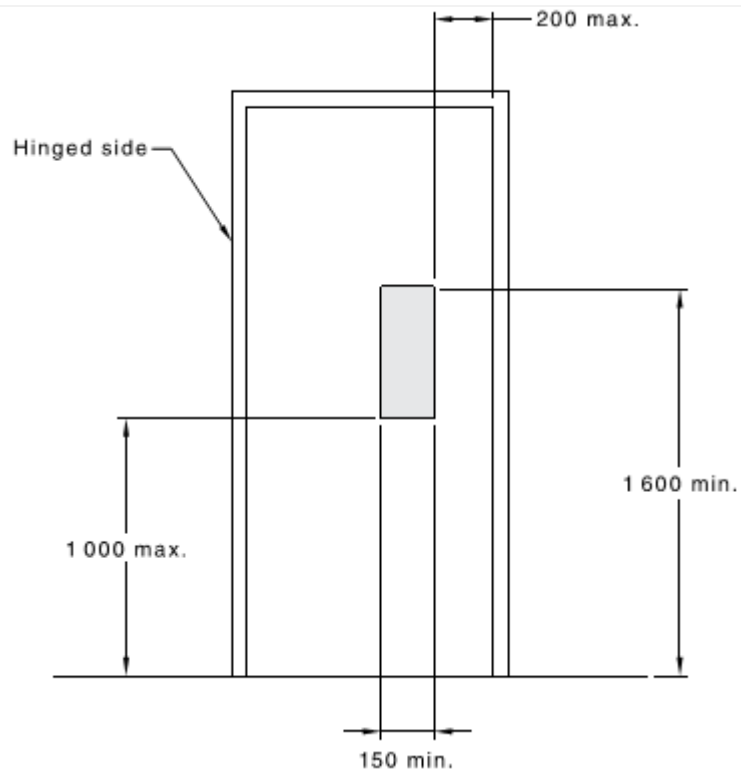

Figure 38

SAI Global Ltd License 1704-c045-2



Part E3 – Lift Installations

E3D3 Stretcher facility lifts	ADR	N/A	C
<p>(a) a stretcher facility in accordance with (b) must be provided;</p> <p>I. In at least one emergency lift required by E3D5</p> <p>II. When an emergency lift is not required, if passenger lifts are installed to serve any storey above an effective height of 12m, in at least one of those lifts to serve each floor served by the lifts</p> <p>Notes: Subject to BCA Consultant review and confirmation, can be compliant at the CC stage & as per the manufacturer's specifications.</p>	<input type="checkbox"/>	<input type="checkbox"/>	✓
<p>(b) a stretcher facility must accommodate a raised stretcher providing a clear space not less than 600mm wide x 2000mm long x 1400mm high above the floor level</p> <p>Notes: Subject to BCA Consultant review and confirmation, can be compliant at the CC stage & as per the manufacturer's specifications.</p>	<input type="checkbox"/>	<input type="checkbox"/>	✓
E3D7 Passenger lift types and their limitations	ADR	N/A	C
<p>(1) In an accessible building, every passenger lift must be one of the following lift types, subject to the limitations (if any) of each lift type:</p> <p>(a) There are no limitations on the use of electric passenger lifts, electrohydraulic passenger lifts or inclined lifts.</p> <p>A passenger lift referred to in (1) must not rely on a constant pressure device for its operation if the lift car is fully enclosed.</p> <p>Notes: Can be compliant at the CC stage & as per manufacturer specifications.</p>	<input type="checkbox"/>	<input type="checkbox"/>	✓
E3D8 Accessible features required for passenger lifts	ADR	N/A	C
<p>Stairway platform lift; Must Not –</p> <p>(a) be used to serve a space in a building accommodating more than 100 persons calculated according to D2D18</p> <p>(b) be used in a high traffic public use area such as a theatre, cinema, auditorium, transport interchange, shopping centre or the like</p> <p>(c) be used where it is possible to install another type of passenger lift</p> <p>(d) connect more than 2 storeys</p> <p>(e) where more than 1 stairway lift is installed, serve more than 2 consecutive storeys</p> <p>(f) when in the folded position, encroach on the minimum width of stairway required by D2D8 to D2D11</p>	<input type="checkbox"/>	✓	<input type="checkbox"/>
<p>Low-rise platform lift;</p> <p>Must not travel more than 1000mm</p>	<input type="checkbox"/>	✓	<input type="checkbox"/>
<p>Low-rise, low-speed constant pressure lift; Must not –</p> <p>(a) for an enclosed type travel more than 4m</p> <p>(b) for an unenclosed type, travel more than 2m</p> <p>(c) be used in high traffic public use areas in buildings such as a theatre, cinema, auditorium, transport interchange, shopping complex or the like</p>	<input type="checkbox"/>	✓	<input type="checkbox"/>
<p>Small sized, low-speed automatic lift;</p> <p>Must not travel more than 12m</p>	<input type="checkbox"/>	✓	<input type="checkbox"/>

E3D8 Accessible features required for passenger lifts	ADR	N/A	C
All lifts except “stair platform lift” and “low-rise platform lift” have handrails complying with the provisions for a mandatory handrail in AS1735.12 Notes: Can be compliant at the CC stage & as per manufacturer specifications.	<input type="checkbox"/>	<input type="checkbox"/>	✓
All lifts which travel more than 12m to have lift floor dimension of not less than 1400mm wide x 1600mm deep Notes: Can be compliant at the CC stage & as per manufacturer specifications.	<input type="checkbox"/>	<input type="checkbox"/>	✓
All lifts which travel not more than 12m “excluding stairway platform lift” to have lift floor dimension of not less than 1100mm wide x 1400mm deep	<input type="checkbox"/>	✓	<input type="checkbox"/>
Floor dimension for a stairway platform lift of not less than 810 mm wide x 1200 mm deep	<input type="checkbox"/>	✓	<input type="checkbox"/>
Minimum door opening complying with AS 1735.12 for All lifts except a stairway platform lift Notes: Can be compliant at the CC stage & as per manufacturer specifications.	<input type="checkbox"/>	<input type="checkbox"/>	✓
Passenger protection system complying with AS 1735.12 for all lifts with a power operated door Notes: Can be compliant at the CC stage & as per manufacturer specifications.	<input type="checkbox"/>	<input type="checkbox"/>	✓
Lift landing doors at the upper landing to be provided for All lifts except “stairway platform lift” Notes: Can be compliant at the CC stage & as per manufacturer specifications.	<input type="checkbox"/>	<input type="checkbox"/>	✓
Lift car and landing control buttons to comply with AS 1735.12 for All lifts except a “stairway platform lift” and “low-rise platform lift” Notes: Can be compliant at the CC stage & as per manufacturer specifications.	<input type="checkbox"/>	<input type="checkbox"/>	✓
Lighting in accordance with AS 1735.12 for all enclosed lift cars Notes: Can be compliant at the CC stage & as per manufacturer specifications.	<input type="checkbox"/>	<input type="checkbox"/>	✓
All lifts servicing more than 2 levels; (a) Automatic audible information within the lift car to identify the level each time the car stops, and (b) Audible and visual indication at each lift landing to indicate the arrival of the lift car, and (c) Audible information and audible indication required by (z) and (b) is to be provided in a range of between 20-80 dB(A) at a maximum frequency of 1500 Hz Notes: Can be compliant at the CC stage & as per manufacturer specifications.	<input type="checkbox"/>	<input type="checkbox"/>	✓
All lifts except “stairway platform lift” to have an emergency hands-free communication, including a button that alerts a call centre of a problem and a light to signal that the call has been received Notes: Can be compliant at the CC stage & as per manufacturer specifications.	<input type="checkbox"/>	<input type="checkbox"/>	✓

(g) where two or more of each type of accessible unisex sanitary facility are provided, the number of left and right-handed facilities must be provided as evenly as possible Notes: See Att. 01 – ‘LH’ and ‘RH’ accessible WC’s have been provided and can be compliant at CC stage in accordance with AS1428.1-2021	<input type="checkbox"/>	<input type="checkbox"/>	✓
(h) where male and female sanitary facility are provided at a separate location of female sanitary facilities, accessible unisex sanitary facility are only required at one of those locations.	<input type="checkbox"/>	✓	<input type="checkbox"/>
(i) an accessible unisex sanitary or an accessible unisex shower need not be provided on a storey or level that is not required by D4D4(f) to be provided with a passenger lift or ramp complying with AS 1428.1	<input type="checkbox"/>	✓	<input type="checkbox"/>
(j) Baby change tables cannot encroach into the circulation space. Maximum height to be 820mm with 720mm underneath when in an open position.	<input type="checkbox"/>	✓	<input type="checkbox"/>



Part F4 – References

The references below to be read as set and referenced in each section of part F4



Figure 38

SAI Global Ltd License 1704-c045-2

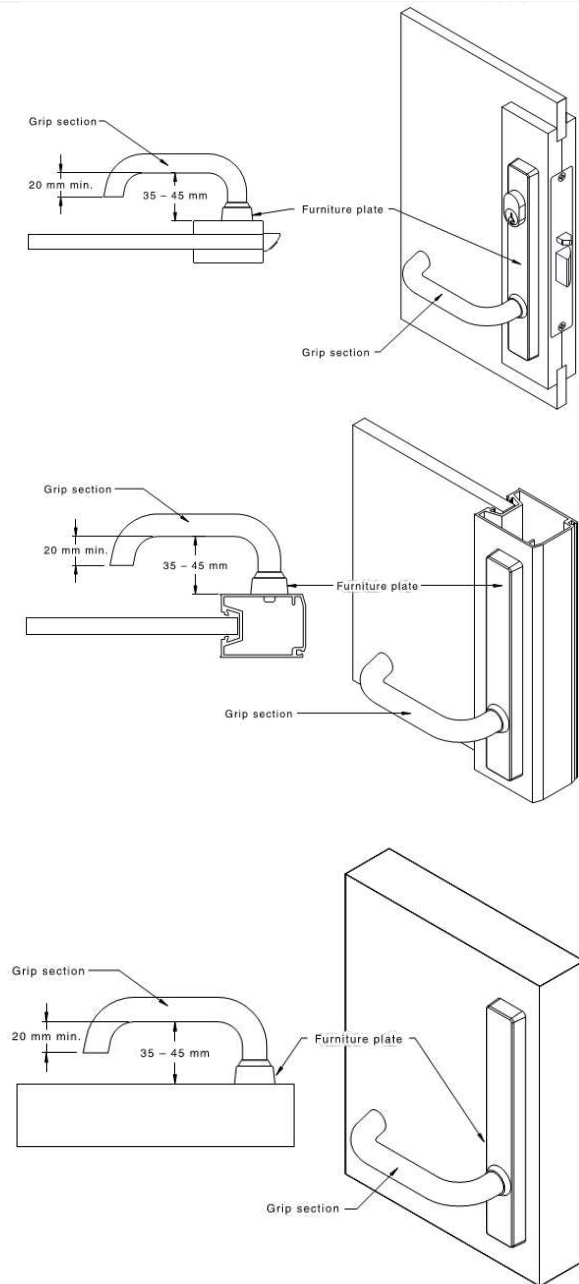
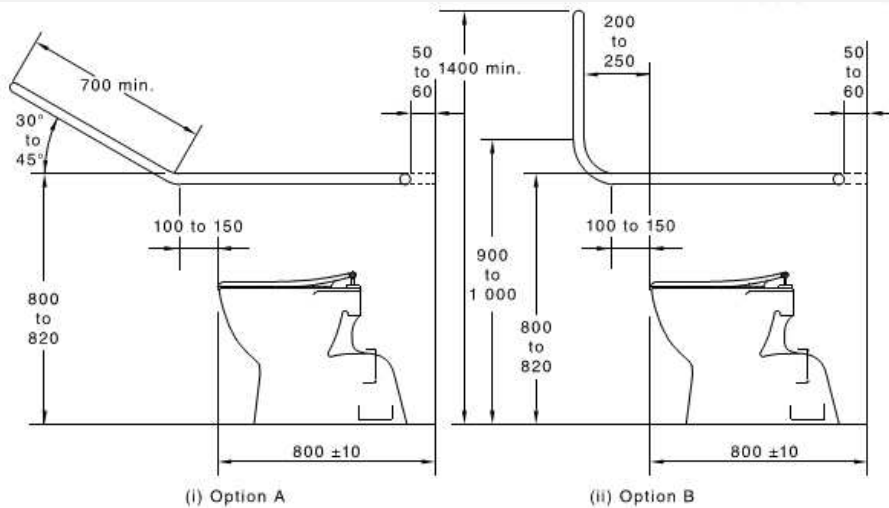
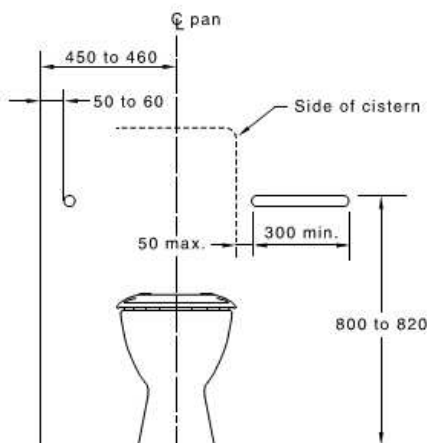

Figure 39

SAI Global Ltd License 1704-c045-2



(a) Side view showing optional systems for grabrail at sides of pan



(b) Grabrail at back of pan with surface-mounted cistern and sectional view of grabrail at side of pan

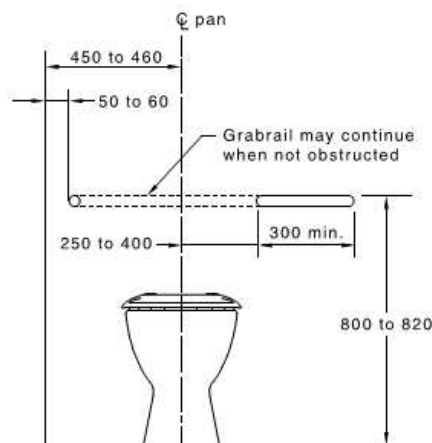

(c) Grabrail at back of pan with concealed or remote cistern and sectional view of grabrail at side of pan

Figure 40

SAI Global Ltd License 1704-c045-2

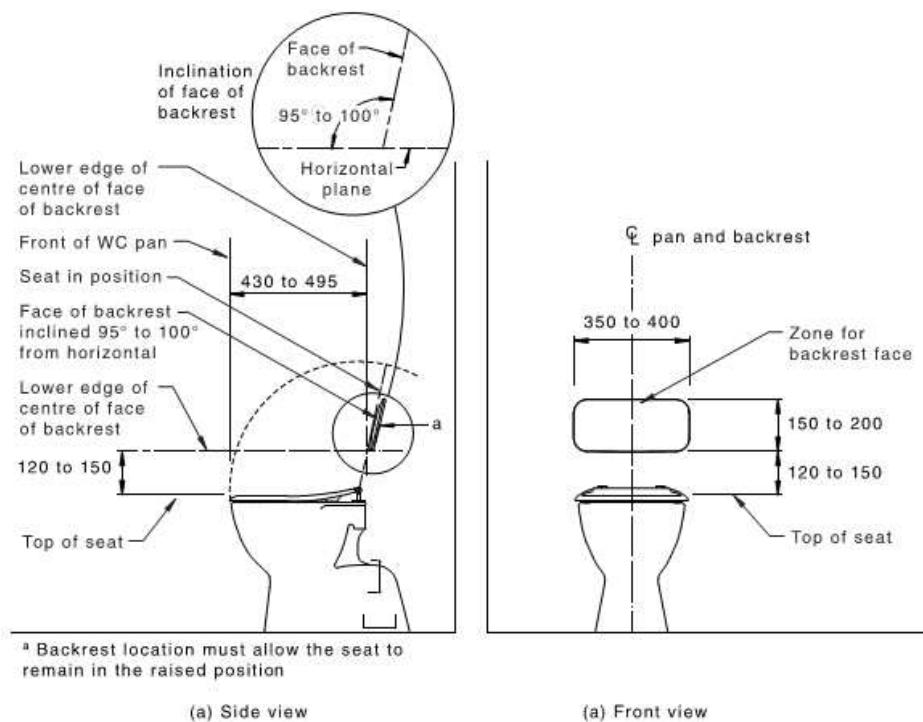

^a Backrest location must allow the seat to remain in the raised position

Figure 41

SAI Global Ltd License 1704-c045-2

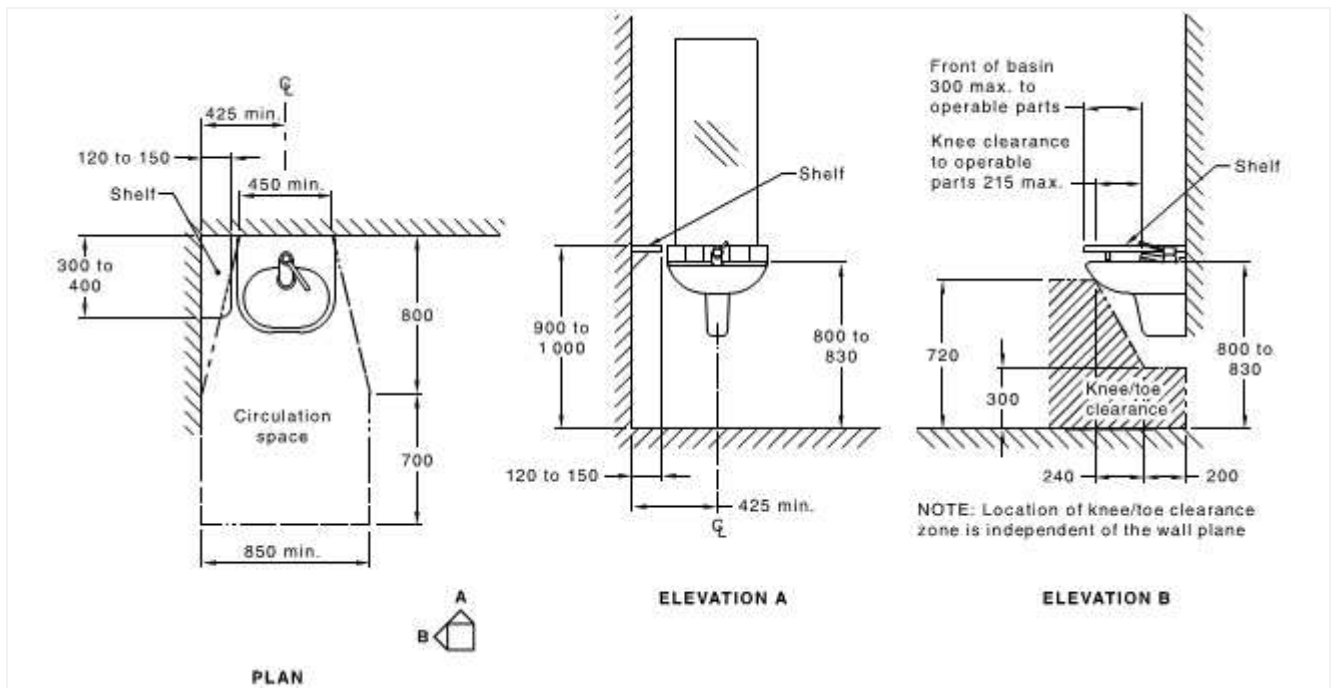

Wall-mounted washbasin installation – other than for sole-occupancy unit

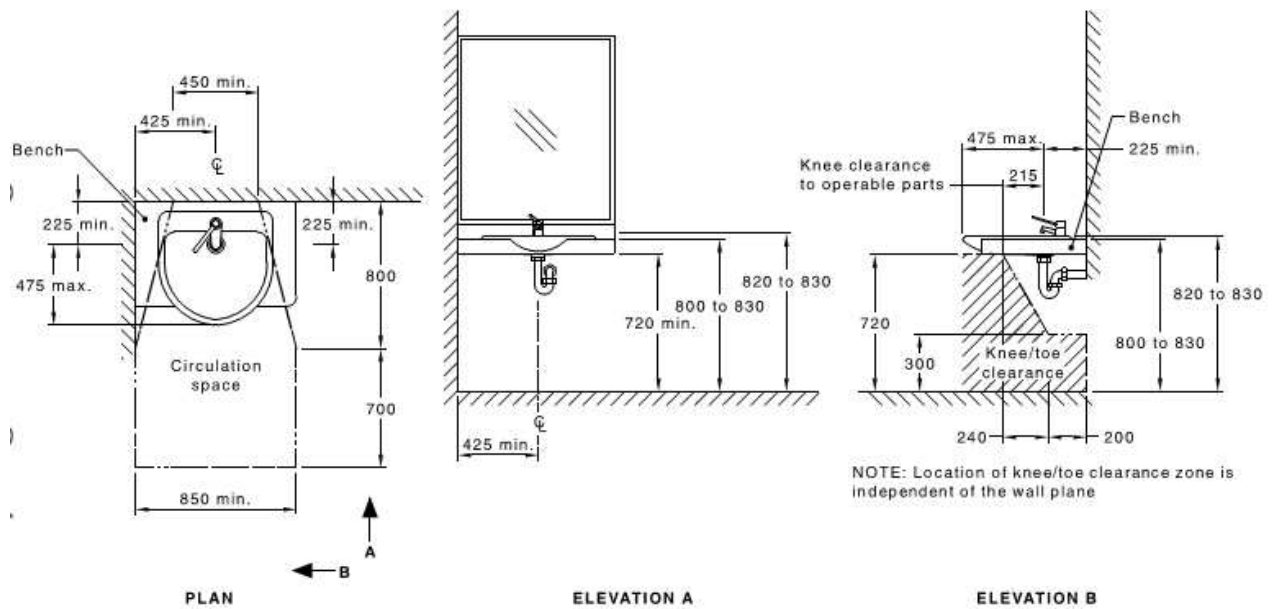

Washbasin for sole-occupancy unit

Figure 42

SAI Global Ltd License 1704-c045-2

Fixtures and fittings within a sanitary facility

Mirrors

In all sanitary facilities, a mirror shall be provided and located either above or adjacent to the washbasin.

Where located above the washbasin, the mirror shall extend from a height of not more than 900 mm to a height of not less than 1 850 mm above the plane of the finished floor. Where located adjacent to a washbasin, the mirror shall extend from a height of not more than 780 mm to a height of not less than 1 850 mm above the plane of the finished floor.

No mirror shall be less than 350 mm wide. All dimensions apply to the reflective surface of the mirror. The reflective surface shall be vertical.

In an accessible sole occupancy unit, a mirror shall be centred over the washbasin.

Shelves

Shelf space shall be provided adjacent to the washbasin in one of the following ways:

- (a)** As a vanity top at a height of 800 mm to 830 mm and a minimum width of 120 mm and a minimum depth of 300 mm and a depth no greater than of the bowl plus its front and back flanges without encroaching into the circulation space of any other fixture.
- (b)** As a separate fixture —
 - (i)** within any circulation space at a height of 900 mm to 1000 mm with a width of 120 mm to 150 mm and length of 300 mm to 450 mm; and
 - (ii)** external to all circulation spaces at a height of 790 mm to 1 000 mm with a minimum width of 120 mm and minimum length of 400 mm.

Soap dispensers, towel dispensers and similar fittings

Where provided, soap dispensers, towel dispensers, hand dryers and similar fittings shall be operable by one hand, and shall be installed with the height of their operative component or outlet not less than 900 mm and not more than 1 100 mm above the plane of the finished floor, and no closer than 500 mm from an internal corner.

Clothes-hanging devices

A clothes-hanging device shall be installed 1200 mm to 1350 mm above the plane of the finished floor and not less than 500 mm out from any internal corner.

Sanitary disposal unit

Where provided, the sanitary disposal unit shall be located as follows:

- (a)** Portable unit as shown in Figure 44.
- (b)** Recessed unit within 500 mm from the pan.

Switches and general purpose outlets

Where provided near the washbasin, switches and general purpose outlets shall be located in accordance with Figure 37 and as close to the shelf or worktop as practicable.

NOTE For requirements on general wiring rules refer to AS/NZS 3000.

Figure 43

SAI Global Ltd License 1704-c045-2

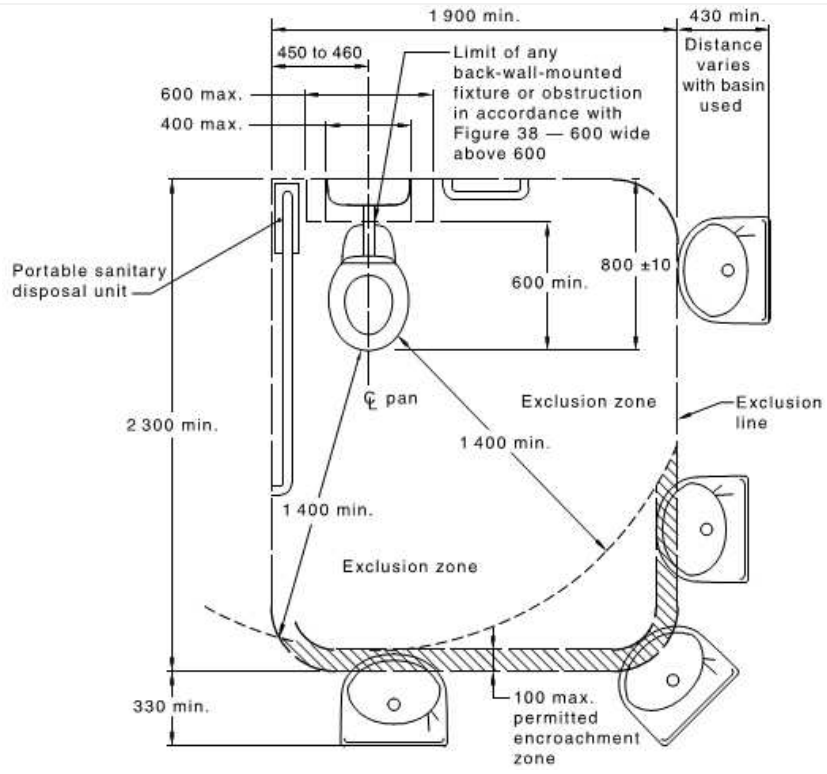
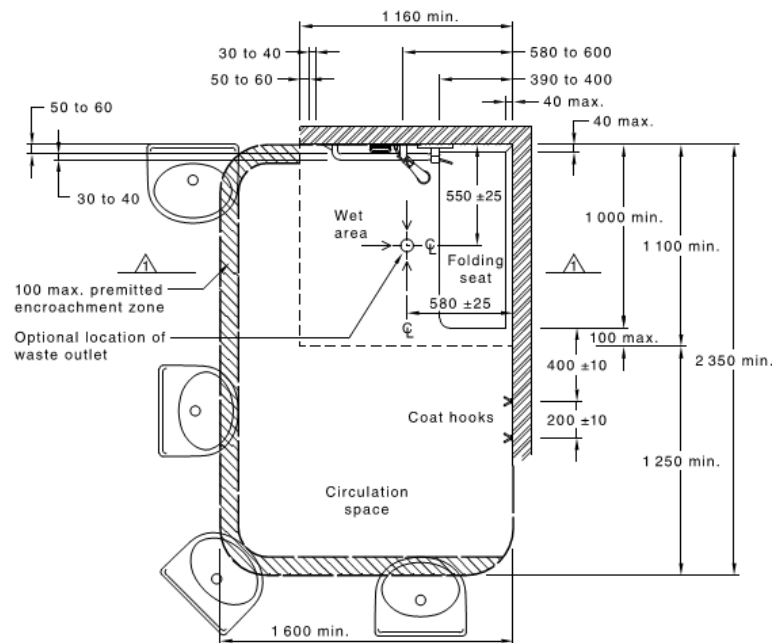
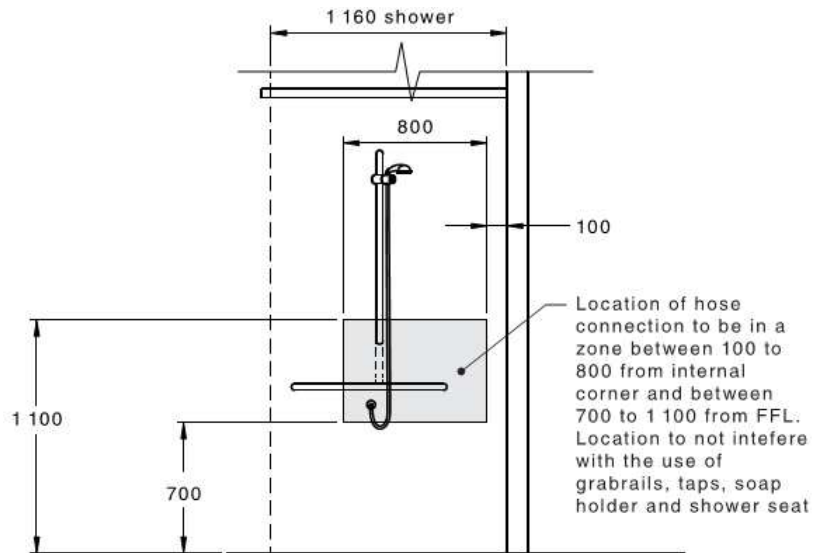
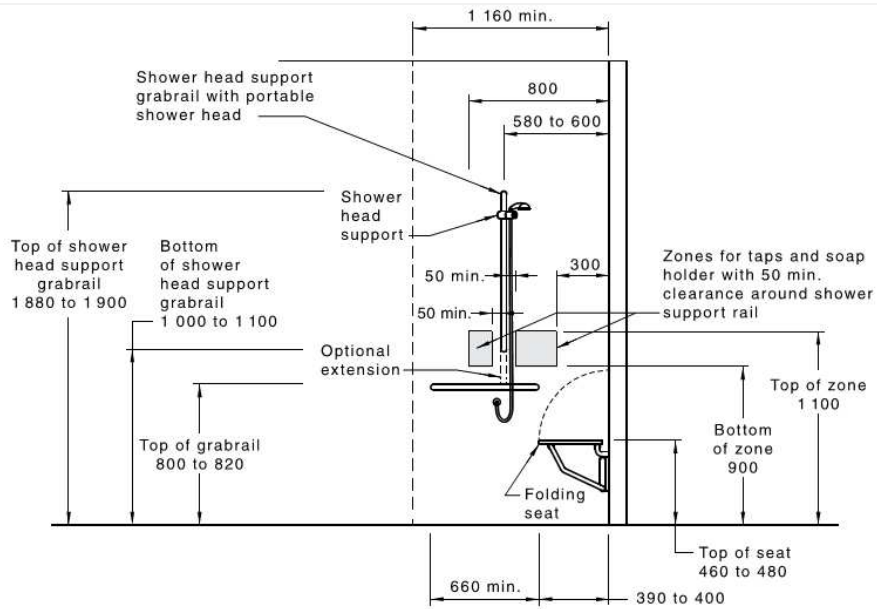

Figure 44

SAI Global Ltd License 1704-c045-2



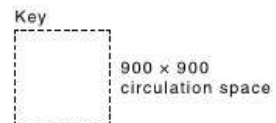
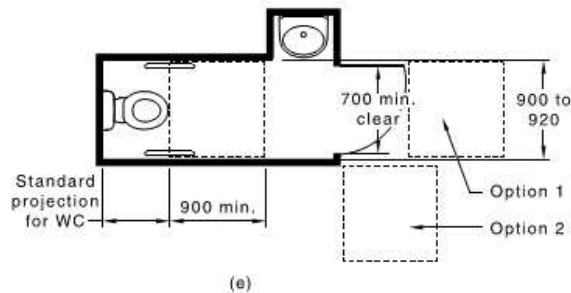
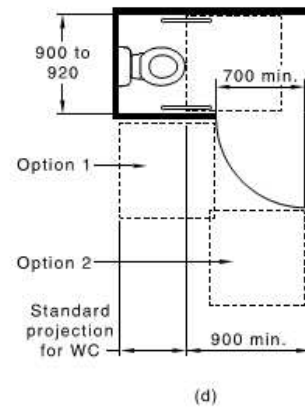
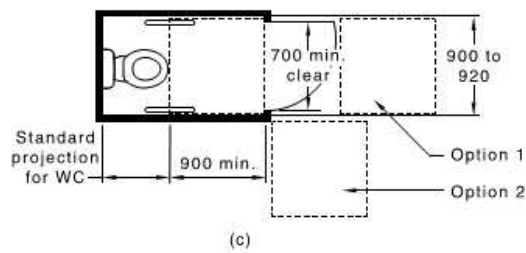
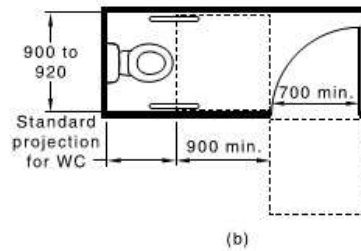
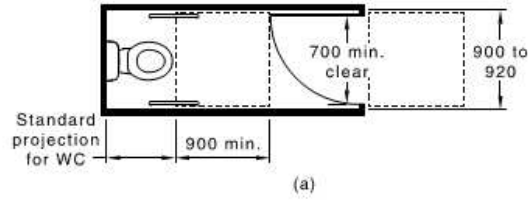
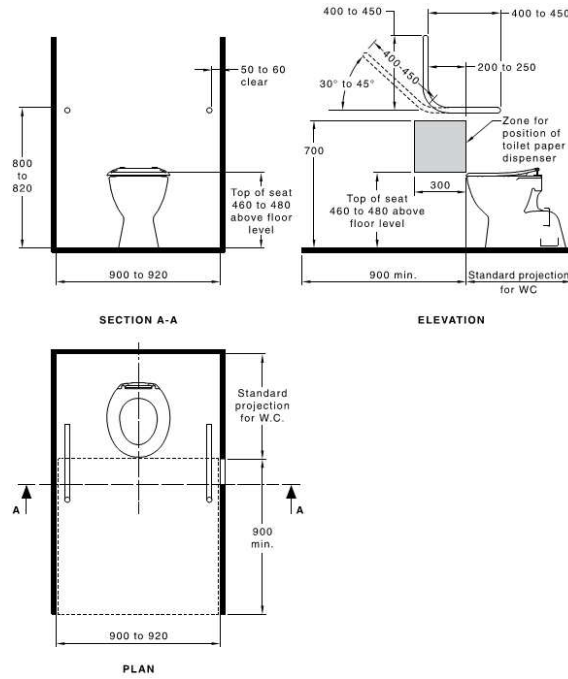

Figure 46

SAI Global Ltd License 1704-c045-2

AS 4299 – 1995 Adaptable Housing Requirements

This schedule is a list of essential features to be incorporated into a housing unit for it to be termed an ‘Adaptable House’. **42 Adaptable units** are required as per Liverpool City Councils DCP (10% of total amount).

The units must achieve **Class C** compliance as per AS4299 Checklist below where all essential features are incorporated. Some requirements are achieved at post adaptation where noted.

The below listed units have been chosen as “Adaptable units”

BUIDING B (158 UNITS)	ADAPTABLE	BUIDING C (244 UNITS)	ADAPTABLE
LEVEL 04	B.401, B.412, B.415	MEZZANINE	C.M08
LEVEL 05	B.501, B.512, B.516	LEVEL 01	C.107, C.113, C.124
LEVEL 06	B.601, B.612, B.616	LEVEL 02	C.207, C.213, C.224
LEVEL 07	B.701, B.712, B.716	LEVEL 03	C.307, C.313, C.324
LEVEL 08	B.801, B.812, B.816	LEVEL 04	C.407, C.413, C.424
LEVEL 09	B.913	LEVEL 05	C.507, C.513, C.523
TOTAL	16 (10.1%)	LEVEL 06	C.607, C.613, C.623
		LEVEL 07	C.707, C.713, C.723
		LEVEL 08	C.807, C.813, C.823
		LEVEL 09	C.907
		TOTAL	26 (10.6%)

R = Required

C = Capable of Compliance by adding the requirement to the project specifications or at post adaptation stage.

Item No.	Clause No.	Requirements as per AS4299	R	C	Comments
DRAWINGS					
1	2.3	Provision of drawings showing the housing unit in its pre-adaption and post-adaption stages.	✓	✓	Can be compliant at post adaptation
SITING					
3	3.3.2	A continuous accessible path of travel from street frontage and vehicle parking to entry complying with AS 1428.1	✓	✓	Complies.
LETTER BOXES IN ESTATE DEVELOPMENTS					
11	3.8	Letterboxes to be on hard standing area connected to accessible pathway	✓	✓	Letterboxes for adaptable units to be at a height of 900-1100mm above FFL
PRIVATE CAR ACCOMODATION					
14	3.7.2	Car parking space or garage min. area 6.0 m x 3.8 m	✓	✓	Parking spaces being provided in accordance with AS2890.6
ACCESSIBLE ENTRY					
20	4.3.1	Accessible entry	✓	✓	Can be compliant at post adaptation
22	4.3.2	Accessible entry to be level (i.e. max. 1:40 slope)	✓	✓	Can be compliant at post adaptation
23	4.3.2	Threshold to be low-level	✓	✓	Can be compliant at post adaptation
24	4.3.2	Landing to enable wheelchair manoeuvrability	✓	✓	Can be compliant at post adaptation
25	4.3.1	Accessible entry door to have 850 mm min. clearance	✓	✓	Can be compliant at post adaptation
27	4.3.4	Door lever handles and hardware to AS 1428.1	✓	✓	Can be compliant at post adaptation

INTERIOR GENERAL					
32	4.3.3	Internal doors to have 820 mm min. clearance	✓	✓	Can be compliant at post adaptation
33	4.3.7	Internal corridors min. width of 1000 mm	✓	✓	
34	4.3.7	Provision for compliance with AS 1428.1 for door approaches	✓	✓	Can be compliant at post adaptation
LIVING ROOM & DINING ROOM					
36	4.7.1	Provision for circulation space of min. 2250 mm diameter	✓	✓	Can be compliant at post adaptation
38	4.7.4	Telephone adjacent to GPO	✓	✓	Notes on plans
41	4.10	Potential illumination level min. 300 lux	✓	✓	Notes on plans
KITCHEN					
42	4.5.2	Minimum width 2.7 m (1550 mm clear between benches)	✓	✓	Can be compliant at post adaptation
43	4.5.1	Provision for circulation at doors to comply with AS 1428.1	✓	✓	Can be compliant at post adaptation
44	4.5.5	Provision for benches planned to include at least one work surface of 800 mm length, adjustable in height from 750 mm to 850 mm or replaceable. Refer to Figure 4.8	✓	✓	Can be compliant at post adaptation
45	4.5.5	Refrigerator adjacent to work surface	✓	✓	Can be compliant at post adaptation
46	4.5.6	Kitchen sink adjustable to heights from 750 mm to 850 mm or replaceable	✓	✓	Can be compliant at post adaptation
47	4.5.6	Kitchen sink bowl max. 150 mm deep	✓	✓	Can be compliant at post adaptation
48	4.5.6 e	Tap set capstan or lever handles or lever mixer	✓	✓	Can be compliant at post adaptation
49	4.5.6 e	Tap set located within 300 mm of front of sink	✓	✓	Can be compliant at post adaptation
51	4.5.7	Cooktops to include either front or side controls with raised cross bars	✓	✓	Can be compliant at post adaptation
52	4.5.7	Cooktops to include isolating switch	✓	✓	Can be compliant at post adaptation
53	4.5.7	Work surface min. 800 mm length adjacent to cooktop at same height	✓	✓	Can be compliant at post adaptation
54	4.5.8	Oven located adjacent to an adjustable height or replaceable work surface	✓	✓	Can be compliant at post adaptation
59	4.5.11	GPOs to comply with AS 1428.1. At least one double GPO within 300 mm of front of work surface	✓	✓	Can be compliant at post adaptation
60	4.5.11	GPO for refrigerator to be easily reachable when the refrigerator is in its operating position	✓	✓	Can be compliant at post adaptation
61	4.5.4	Slip-resistant floor surface	✓	✓	Can be compliant at post adaptation
MAIN BEDROOM					
62	4.6.1	At least one bedroom of area sufficient to accommodate queen size bed and wardrobe and circulation space requirements of AS 1428.2	✓	✓	Can be compliant at post adaptation
BATHROOM					
75	4.4.1	Provision for bathroom area to comply with AS 1428.1	✓	✓	A bathroom with the minimum dimension of 2.05x2.95m or 2.3x2.7m or 2.4x2.45m
76	4.4.2	Slip-resistant floor surface	✓	✓	Can be compliant at post adaptation
77	4.4.4f	Shower recess- no hob. Minimum size 1160 × 1100 to comply with AS 1428.1. (Refer Figures 4.6 and 4.7)	✓	✓	Can be compliant at post adaptation
78	4.4.4f	Shower area waterproofed to AS 3740 with floor to fall to waste	✓	✓	Can be compliant at post adaptation
79	4.4.4f	Recessed soap holder	✓	✓	Can be compliant at post adaptation
80	4.4.4f	Shower taps positioned for easy reach to access side of shower sliding track	✓	✓	Can be compliant at post adaptation

82	4.4.4h	Provision for adjustable, detachable hand held shower rose mounted on a slider grab rail or fixed hook	✓	✓	Can be compliant at post adaptation
83	4.4.4h	Provision for grab rail in shower (Refer to Figure 4.7) to comply with AS 1428.1	✓	✓	Can be compliant at post adaptation
86	4.4.4c	Tap sets to be capstan or lever handles with single outlet	✓	✓	Can be compliant at post adaptation
88	4.4.4g	Provision for washbasin with clearances to comply with AS 1428.1	✓	✓	Can be compliant at post adaptation
90	4.4.4d	Double GPO beside mirror 4.4.4(d)	✓	✓	Can be compliant at post adaptation
TOILET					
92	4.4.3	Provision of either 'visitable toilet' or accessible toilet	✓	✓	Can be compliant at post adaptation
93	4.4.1	Provision to comply with AS 1428.1	✓	✓	Can be compliant at post adaptation
94	4.4.3	Location of WC pan at correct distance from fixed walls	✓	✓	Can be compliant at post adaptation
95	4.4.4b	Provision for grab rail zone. (Refer Figure 4.6)	✓	✓	Can be compliant at post adaptation
96	4.4.2	Slip resistant floor surface. (Vitreous tiles or similar)	✓	✓	Can be compliant at post adaptation
LAUNDRY					
98	4.8	Circulation at doors to comply with AS 1428.1	✓	✓	Can be compliant at post adaptation
99	4.8	Provision for adequate circulation space in front of or beside appliances (min. 1550 mm depth)	✓	✓	Can be compliant at post adaptation
100	4.8 e	Provision for automatic washing machine	✓	✓	Can be compliant at post adaptation
102	4.8a	Where clothes line is provided, an accessible path of travel to this	✓	✓	
105	4.8 g	Double GPO	✓	✓	Can be compliant at post adaptation
108	4.9.1	Slip-resistant floor surface	✓	✓	Can be compliant at post adaptation
DOORLOCKS					
110	4.3.4	Door hardware operable with one hand, located 900–1100 mm above floor	✓	✓	Can be compliant at post adaptation
FLOOR COVERINGS					
111	4.9.4	Slip resistant surfaces – balconies and all external paved areas	✓	✓	Can be compliant at CC stage
ANCILLARY ITEMS					
112	4.11.1	Switches located 900-1100mm above floor in line with door handles	✓	✓	Can be compliant at CC stage
113	4.11.1	GPOs located not less than 600mm above floor	✓	✓	Can be compliant at CC stage
114	4.11.2	Electrical distribution board located inside housing unit.	✓	✓	Can be compliant at CC stage
GARBAGE					
116	4.11.6	Provision for bin in accessible location	✓	✓	Can be compliant at CC stage

REQUIREMENT

- Where the location of fixtures such as WC pan, wash basin, sink, shower, laundry fixtures, and any other fixtures are to be relocated at post-adaptation, **All** services pipes (both water and waste supply pipes) have to be laid in accordance with AS 1428.1 and in its specified location at “Post-Adaptation” where all services to be capped-off for future use.

GENERAL RECOMMENDATIONS (ADVISORY ONLY AND NOT MANDATORY)

- Private balconies and outdoor areas provided to the Adaptable units to have recessed sliding doors tracks so level access is provided between the balcony/outdoor area and the internal spaces.
- Sliding or/and Hinged doors leading to private balconies and/or outdoor areas provided to the Adaptable units to have a clear door opening of 850mm with side latch clearance of 530mm
- Consideration to the finishes and method of construction to the wet areas so that flush transition is achieved between the wet area floor and the external/corridor finishes.
- For new kitchen/s in residential development, it is recommended that the kitchen could be made partially accessible by providing a width of 900mm next to the sink as vacant space without the cabinetry under the bench top and a long lever tap with spout handle within 300mm from the edge of the front benchtop. The distance in between benches to achieve 1550mm, in addition to 1x DGPO to be provided within 300mm from the edge of the benchtop.

The references below to be read as set and referenced in each section of Adaptable Housing AS4299

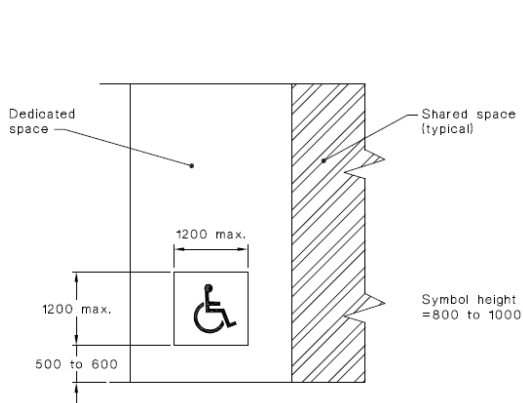

DIMENSIONS IN MILLIMETRES

Figure 47

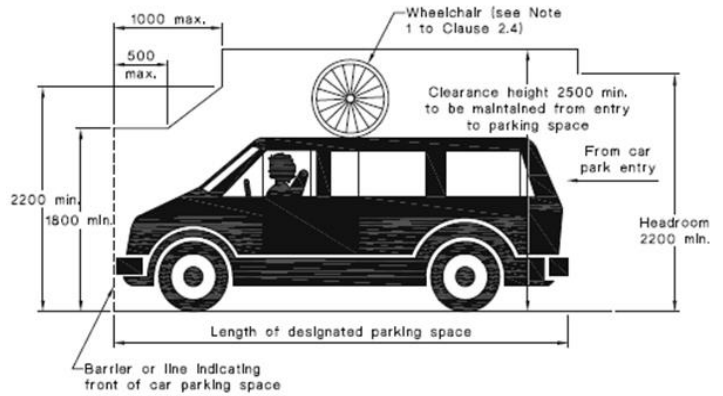

DIMENSIONS IN MILLIMETRES

SAI Global Ltd License 1704-c045-2

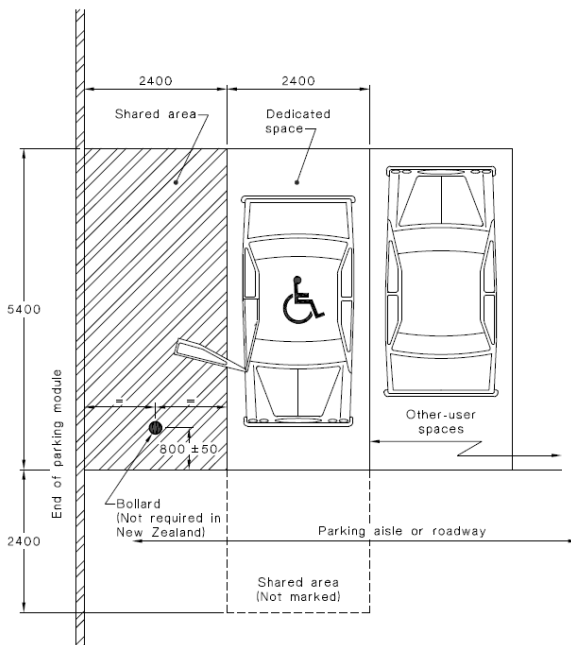

DIMENSIONS IN MILLIMETRES

Figure 48

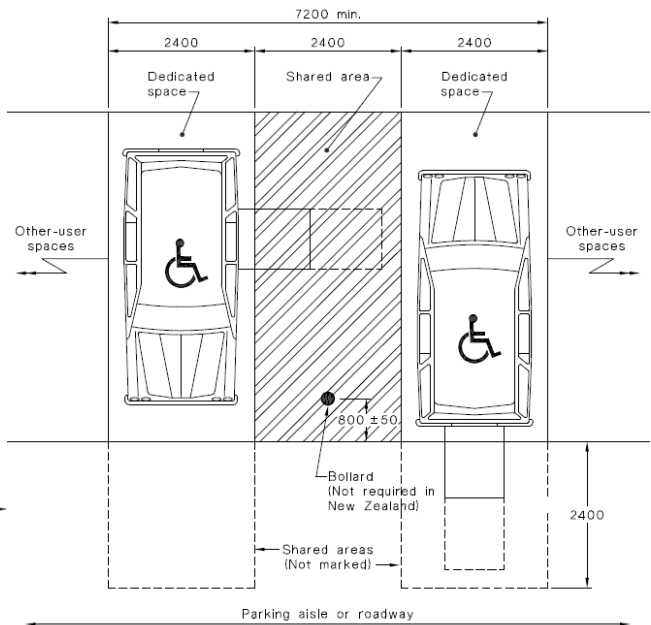

DIMENSIONS IN MILLIMETRES

SAI Global Ltd License 1704-c045-2

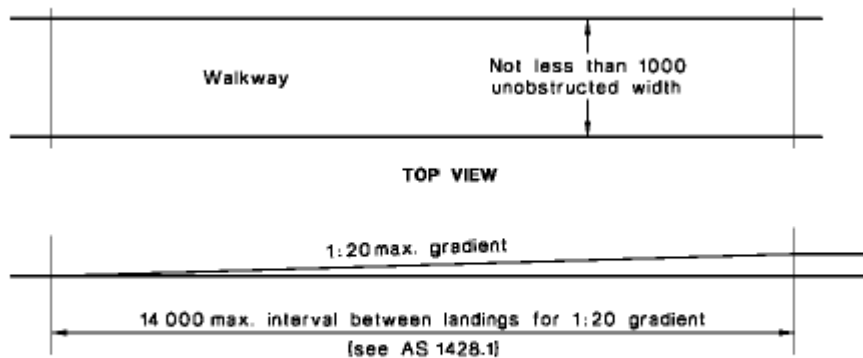

DIMENSIONS IN MILLIMETRES

Figure 49

SAI Global Ltd License 1704-c045-2

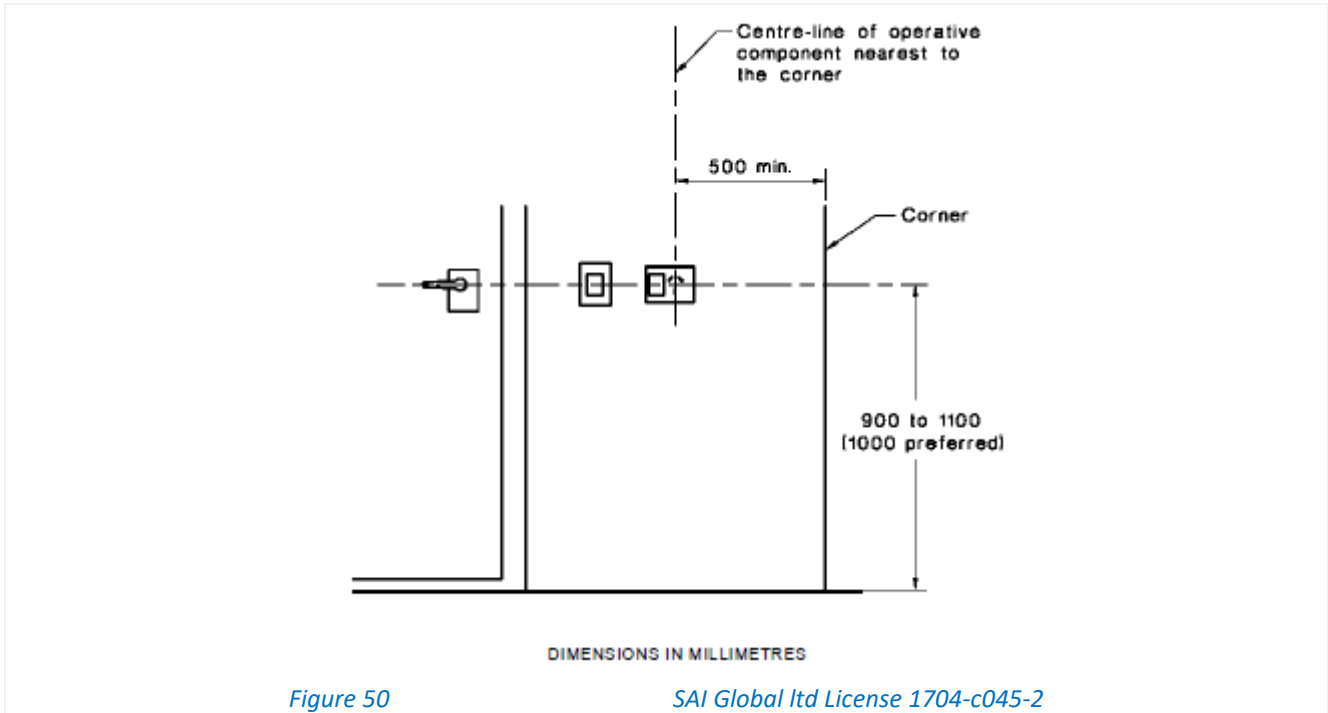
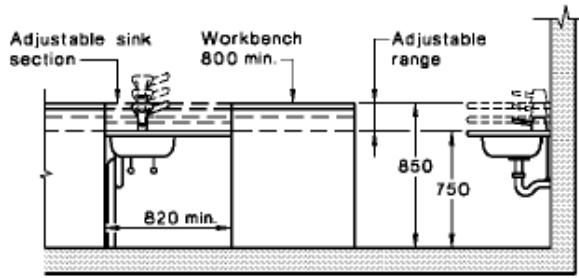

Figure 50

SAI Global Ltd License 1704-c045-2





DIMENSIONS IN MILLIMETRES

FIGURE 4.9 SINKS AFTER MODIFICATION

Figure 51

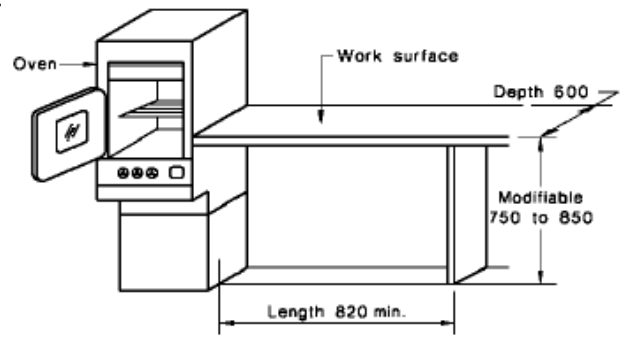

DIMENSIONS IN MILLIMETRES

SAI Global Ltd License 1704-c045-2

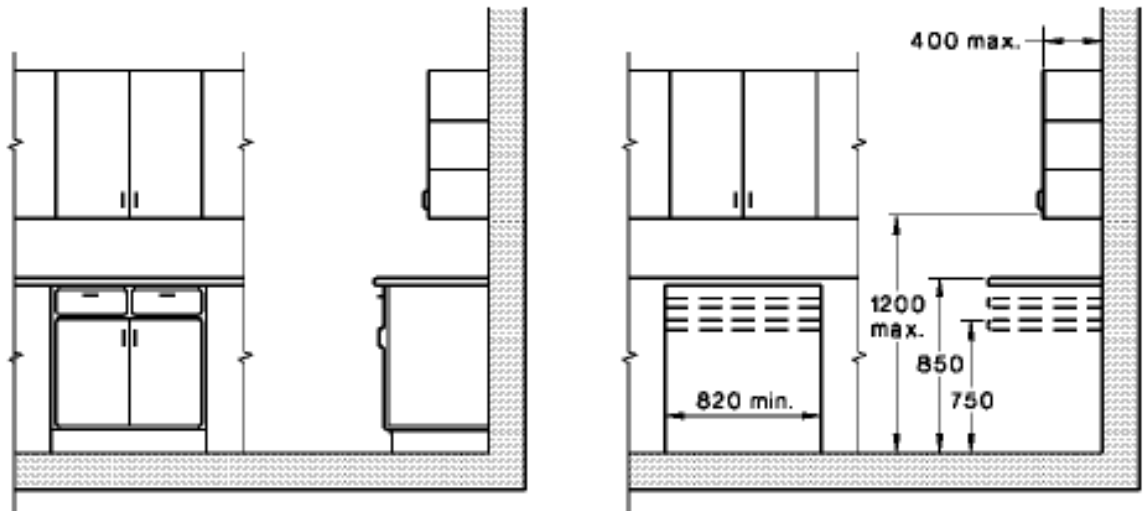

(a) Before removal of cabinets

(b) After removal of cabinets

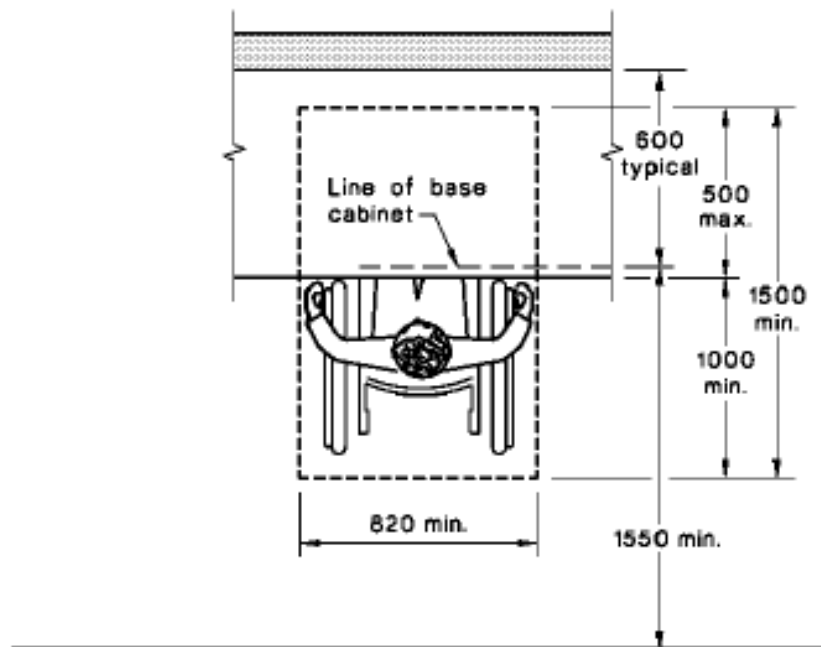

(c) Clear floor space under work surface

Figure 52

SAI Global Ltd License 1704-c045-2

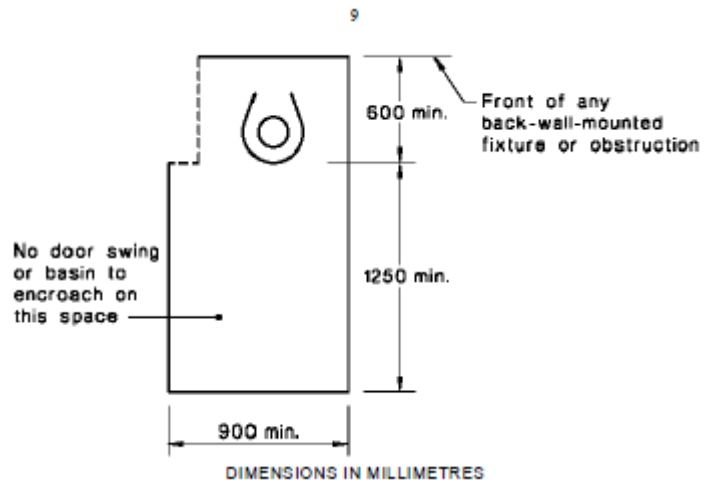

Figure 46

SAI Global Ltd License 1704-c045-2

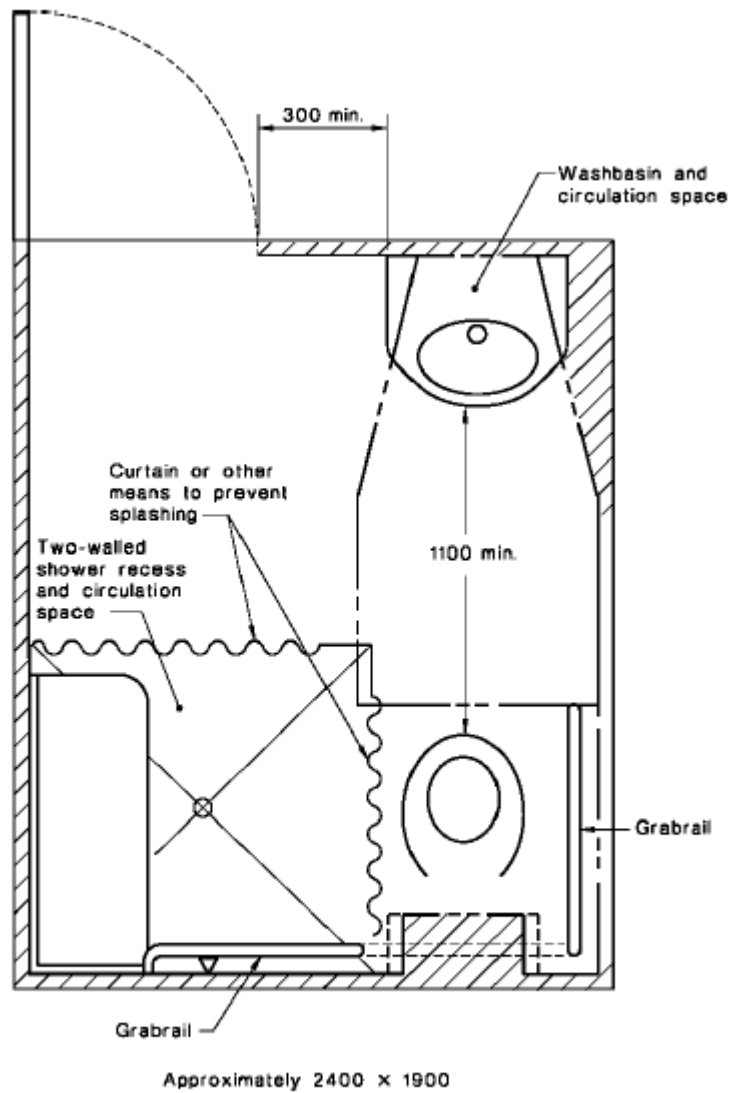
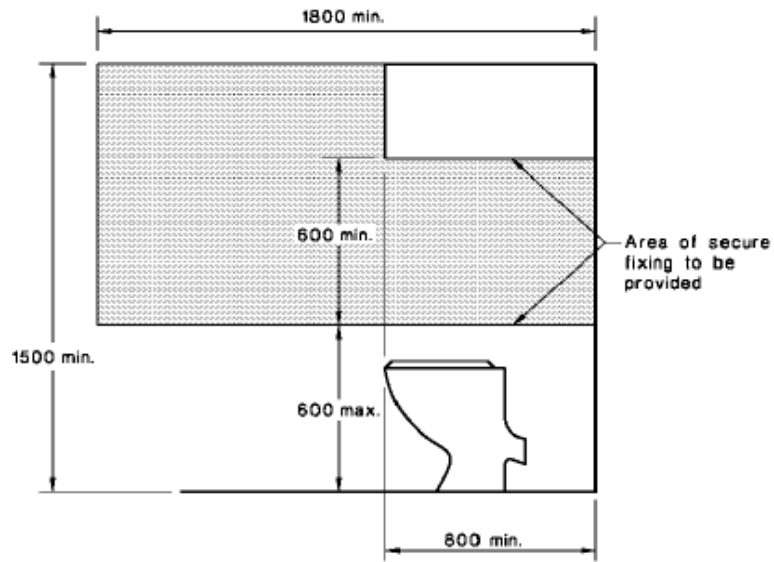
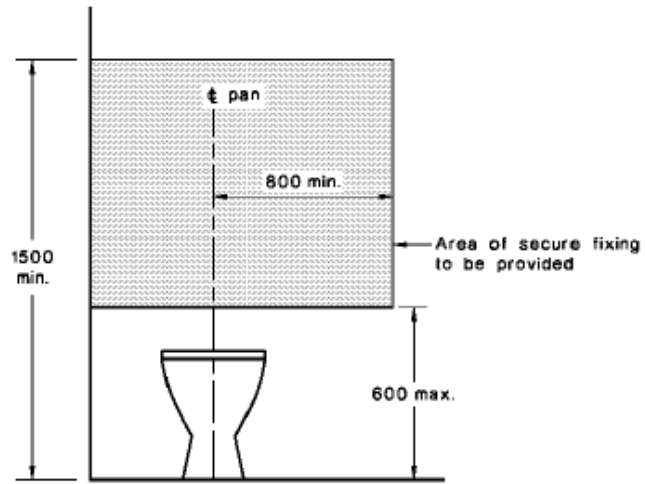

Figure 53

SAI Global Ltd License 1704-c045-2



(a) Side view



(b) Front view

DIMENSIONS IN MILLIMETRES

FIGURE 4.5 REINFORCED AREAS FOR SUBSEQUENT INSTALLATION OF GRABRAILS IN TOILETS

Figure 54

SAI Global Ltd License 1704-c045-2

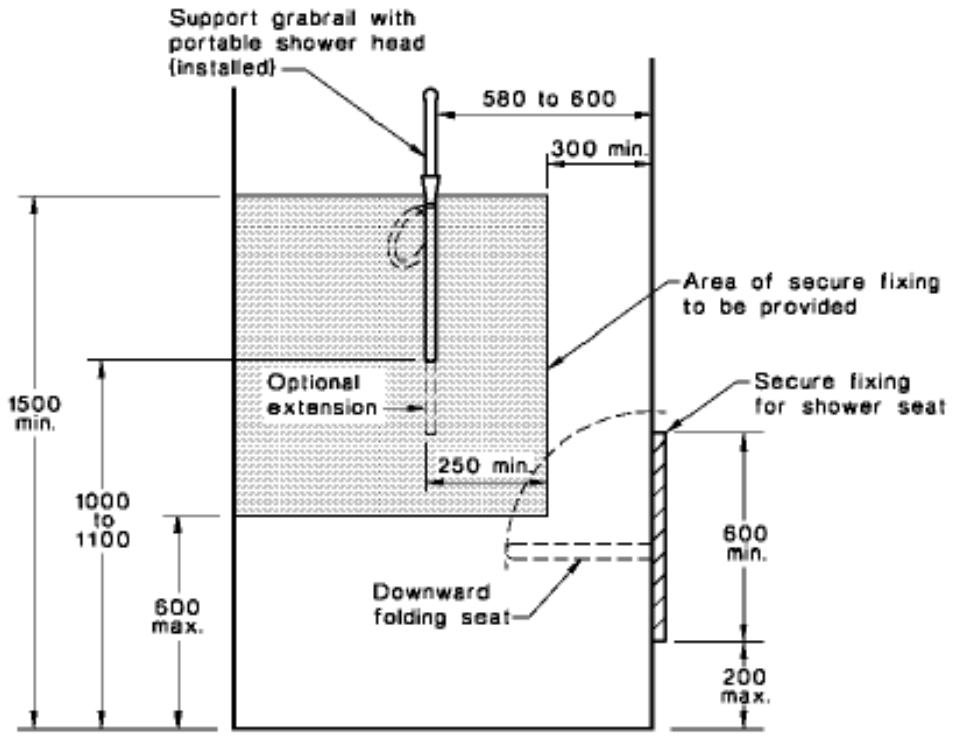

(a) Back wall

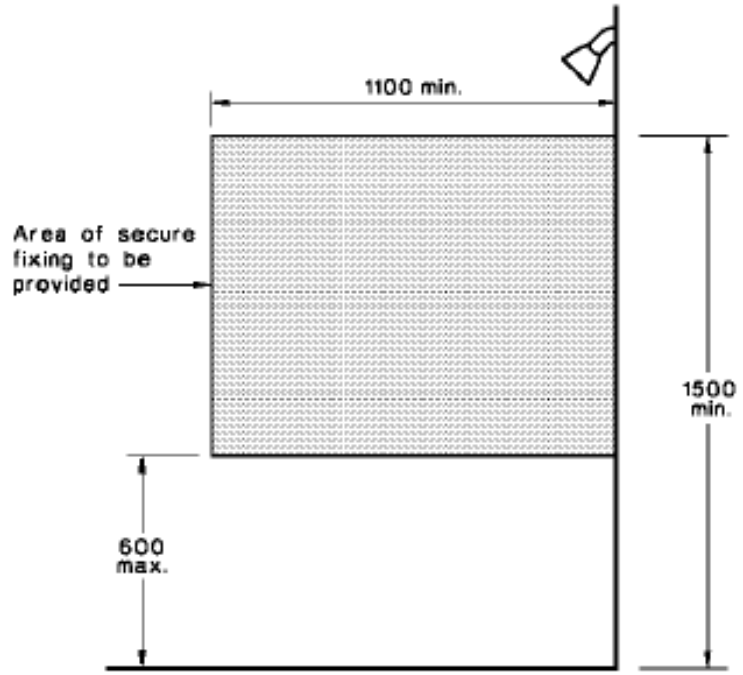

(b) Side wall

DIMENSIONS IN MILLIMETRES

Figure 55

SAI Global Ltd License 1704-c045-2

Adaptable Housing – Pre & Post Adaptable Units

The attachments below are extracted from the Architectural Plans provided and are to be read together with AS 4299 Adaptable Housing Requirements.

Pre-Adaptable Unit XX

<p>2B TYPE 1 (6 UNITS) B.516</p>	<p>ROOM WORKSPACE ADJACENT TO FRIDGE</p>	<p>GRABRAILS FIXED TO WALL PROVIDE GRABRAIL INSTALLATION DURING ADAPTATION CAPPED SERVICES PROVISION ON SLAB FOR POST-ADAPTATION PROVIDE GRABRAIL INSTALLATION DURING ADAPTATION</p>	<p>SITE BOUNDARY HP METRE</p>
	<p>TYPE 1 - PRE ADAPTATION 1:100 @ A1</p>	<p>TYPE 1 - POST ADAPTATION 1:100 @ A1</p>	<p>TYPE 1 - LOCATION 1:1000 @ A1</p>
<p>2B TYPE 2 (5 UNITS) B.512</p>	<p>ROOM WORKSPACE ADJACENT TO FRIDGE</p>	<p>GRABRAILS FIXED TO WALL ROOM WORKSPACE ADJACENT TO FRIDGE PROVIDE GRABRAIL INSTALLATION DURING ADAPTATION CAPPED SERVICES PROVISION ON SLAB FOR POST-ADAPTATION PROVIDE GRABRAIL INSTALLATION DURING ADAPTATION</p>	<p>SITE BOUNDARY HP METRE</p>
	<p>TYPE 2 - PRE ADAPTATION 1:100 @ A1</p>	<p>TYPE 2 - POST ADAPTATION 1:100 @ A1</p>	<p>TYPE 2 - LOCATION 1:1000 @ A1</p>
<p>2B TYPE 3 (5 UNITS) B.501</p>	<p>ROOM WORKSPACE ADJACENT TO FRIDGE</p>	<p>GRABRAILS FIXED TO WALL ROOM WORKSPACE ADJACENT TO FRIDGE PROVIDE GRABRAIL INSTALLATION DURING ADAPTATION CAPPED SERVICES PROVISION ON SLAB FOR POST-ADAPTATION PROVIDE GRABRAIL INSTALLATION DURING ADAPTATION</p>	<p>SITE BOUNDARY HP METRE</p>
	<p>TYPE 3 - PRE ADAPTATION 1:100 @ A1</p>	<p>TYPE 3 - POST ADAPTATION 1:100 @ A1</p>	<p>TYPE 3 - LOCATION 1:1000 @ A1</p>
<p>1B TYPE 4 (8 UNITS) C.224</p>	<p>ROOM WORKSPACE ADJACENT TO FRIDGE</p>	<p>ROOM WORKSPACE ADJACENT TO FRIDGE PROVIDE GRABRAIL INSTALLATION DURING ADAPTATION PROVIDE GRABRAIL INSTALLATION DURING ADAPTATION CAPPED SERVICES PROVISION ON SLAB FOR POST-ADAPTATION GRABRAILS FIXED TO WALL</p>	<p>SITE BOUNDARY HP METRE</p>
	<p>TYPE 4 - PRE ADAPTATION 1:100 @ A1</p>	<p>TYPE 4 - POST ADAPTATION 1:100 @ A1</p>	<p>TYPE 4 - LOCATION 1:1000 @ A1</p>
<p>1B TYPE 5 (10 UNITS) C.207</p>	<p>ROOM WORKSPACE ADJACENT TO FRIDGE</p>	<p>GRABRAILS FIXED TO WALL ROOM WORKSPACE ADJACENT TO FRIDGE CAPPED SERVICES PROVISION ON SLAB FOR POST-ADAPTATION PROVIDE GRABRAIL INSTALLATION DURING ADAPTATION PROVIDE GRABRAIL INSTALLATION DURING ADAPTATION</p>	<p>SITE BOUNDARY HP METRE</p>
	<p>TYPE 5 - PRE ADAPTATION 1:100 @ A1</p>	<p>TYPE 5 - POST ADAPTATION 1:100 @ A1</p>	<p>TYPE 5 - LOCATION 1:1000 @ A1</p>
<p>2B TYPE 6 (8 UNITS) C.213</p>	<p>ROOM WORKSPACE ADJACENT TO FRIDGE</p>	<p>CAPPED SERVICES PROVISION ON SLAB FOR POST-ADAPTATION PROVIDE GRABRAIL INSTALLATION DURING ADAPTATION PROVIDE GRABRAIL INSTALLATION DURING ADAPTATION GRABRAILS FIXED TO WALL ROOM WORKSPACE ADJACENT TO FRIDGE</p>	<p>SITE BOUNDARY HP METRE</p>
	<p>TYPE 6 - PRE ADAPTATION 1:100 @ A1</p>	<p>TYPE 6 - POST ADAPTATION 1:100 @ A1</p>	<p>TYPE 6 - LOCATION 1:1000 @ A1</p>

Adaptable Units prepared by "PLUS STUDIO", Pre & Post Adaptation Typologies Issue No. A, dated 01/10/2025

SEPP 65 – Part 4Q1 Livable Housing Guidelines

As per SEPP 65, 20% of the units are to be designed as ‘Livable’. The development proposes 402 Units, which require 81 Units to be designed as Silver Level ‘Livable’. However, a total of 84 units have been provided as Silver Level LHA units. 42 adaptable units have already been provided and can be used as Livable at both Pre and Post adaptable stages. The remainder of the livable units are listed in the table below.

BUIDING B (158 UNITS)	ADAPTABLE	LIVEABLE	BUIDING C (244 UNITS)	ADAPTABLE	LIVEABLE
LEVEL 04	B.401, B.412, B.415	B.409, B.418, B.401, B.412, B.415	MEZZANINE	C.M08	C.M08
LEVEL 05	B.501, B.512, B.516	B.505, B.510, B.520, B.501, B.512, B.516	LEVEL 01	C.107, C.113, C.124	C.101, C.120, C.121, C.107, C.113, C.124
LEVEL 06	B.601, B.612, B.616	B.605, B.610, B.620, B.601, B.612, B.616	LEVEL 02	C.207, C.213, C.224	C.201, C.220, C.221, C.207, C.213, C.224
LEVEL 07	B.701, B.712, B.716	B.705, B.710, B.720, B.701, B.712, B.716	LEVEL 03	C.307, C.313, C.324	C.301, C.320, C.321, C.307, C.313, C.324
LEVEL 08	B.801, B.812, B.816	B.805, B.810, B.820, B.801, B.812, B.816	LEVEL 04	C.407, C.413, C.424	C.401, C.420, C.421, C.407, C.413, C.424
LEVEL 09	B.913	B.904, B.916, B.913	LEVEL 05	C.507, C.513, C.523	C.501, C.520, C.521, C.507, C.513, C.523
TOTAL	16 (10.1%)	32(20.2%)	LEVEL 06	C.607, C.613, C.623	C.601, C.620, C.621, C.607, C.613, C.623
			LEVEL 07	C.707, C.713, C.723	C.701, C.720, C.721, C.707, C.713, C.723
			LEVEL 08	C.807, C.813, C.823	C.801, C.820, C.821, C.807, C.813, C.823
			LEVEL 09	C.907	C.917, C.918, C.907
			TOTAL	26 (10.6%)	52 (21.3%)

4. A safe continuous and step free path of travel from the street entrance and/ or parking area to a dwelling entrance that is level

	ADR	N/A	C
a. Provide a safe and continuous pathway from: <ul style="list-style-type: none"> I. the front boundary of the allotment; or II. a car parking space, where provided, which may include the driveway on the allotment, to an entrance that is level (step-free) This provision does not apply where the average slope of the ground where the path would feature is steeper than 1:14. Notes: See Att. 02 – Can be compliant at the CC stage	<input type="checkbox"/> <input type="checkbox"/>	<input type="checkbox"/> <input checked="" type="checkbox"/>	<input checked="" type="checkbox"/> <input type="checkbox"/>
b. The path of travel as referred to in (a) should have a minimum clear width of 1000mm and <ul style="list-style-type: none"> I. an even, firm, slip resistant surface; II. a cross fall of not more than 1:40; III. A maximum pathway slope of 1:14, with landings provided at no greater than 9m for a 1:14 ramp and no greater than 15m for ramps steeper than 1:20. Landings should be no less than 200mm in length; and IV. be step-free 	<input type="checkbox"/>	<input type="checkbox"/>	<input checked="" type="checkbox"/>
c. A step ramp may be incorporated at an entrance doorway where there is a change in height of 190mm or less. The step ramp should provide: <ul style="list-style-type: none"> I. a maximum gradient of 1:10 II. a minimum clear width of 1000mm (please note: width should reflect the pathway width) III. a maximum length of 1900mm Level landings no less than 1200mm in length, exclusive of the swing of the door or gate than opens onto them, must be provided at the head and foot of the ramp.	<input type="checkbox"/>	<input type="checkbox"/>	<input checked="" type="checkbox"/>

5. At least one, level (Step free) entrance into the dwelling			
a. The dwelling should provide an entrance door with – <ul style="list-style-type: none"> I. a minimum clear opening width of 820mm (see Figure 2(a)); II. a level (step-free) transition and threshold (maximum vertical tolerance of 5mm between abutting surfaces is allowable provided the lip is rounded or bevelled); and III. Reasonable shelter from the weather. <p>Reference: Figure 56 Notes: See Att. 02 – Can be compliant at the CC stage</p>	<input type="checkbox"/>	<input type="checkbox"/>	✓
b. A level landing area of 1200mm x 1200mm should be provided at the level (step-free) entrance door.	<input type="checkbox"/>	<input type="checkbox"/>	✓
c. Where the threshold at the entrance exceeds 5mm and is less than 56mm, a ramped threshold may be provided.	<input type="checkbox"/>	<input type="checkbox"/>	✓
d. The level (step-free) entrance should be connected to the safe and continuous pathway.	<input type="checkbox"/>	<input type="checkbox"/>	✓
6. Internal doors and corridors that facilitate comfortable and unimpeded movement between spaces.			
a. Doorways to rooms on the entry level used for living, dining, bedroom, bathroom, kitchen, laundry and sanitary compartment purposes should provide: <ul style="list-style-type: none"> I. a minimum clear opening width of 820mm (see Figure 2(a)); and II. A level transition and threshold (maximum vertical tolerance of 5mm between abutting surfaces is allowable provided the lip is rounded or bevelled). <p>Reference: Figure 56 Notes: See Att. 02 – Can be compliant at the CC stage</p>	<input type="checkbox"/>	<input type="checkbox"/>	✓
b. Internal corridors/passageways to the doorways referred to in (a) should provide a minimum clear width of 1000mm.	<input type="checkbox"/>	<input type="checkbox"/>	✓
7. A toilet on the ground (or entry) level that provides easy access.			
a. Dwellings should have a toilet on the ground (or entry) level that provides: <ul style="list-style-type: none"> I. a minimum clear width of 900mm between the walls of the bathroom if located in a separate room; and II. A minimum 1200mm clear circulation space forward of the toilet pan exclusive of the swing of the door in accordance with Figure 3(a). <p>Reference: Figure 57 Notes: See Att. 02 – Can be compliant at the CC stage</p>	<input type="checkbox"/>	<input type="checkbox"/>	✓
b. If the toilet is located within the ground (or entry) level bathroom, the toilet pan should be located in the corner of the room to enable the installation of grab rails. Reference: Figure 58, Figure 59 Notes: See Att. 02 – Can be compliant at the CC stage	<input type="checkbox"/>	<input type="checkbox"/>	✓
8. A bathroom that contains a hob-less (step-free) shower recess.			
a. One bathroom should feature a slip resistant, hobless (step-free) shower recess. Shower screens are permitted provided they can be easily removed at a later date.	<input type="checkbox"/>	<input type="checkbox"/>	✓
b. The shower recess should be located in the corner of the room to enable the installation of grab rails at a future date. Reference: Figure 61 Notes: See Att. 02 – Can be compliant at the CC stage	<input type="checkbox"/>	<input type="checkbox"/>	✓

9. Reinforced walls around the toilet, shower and bath to support the safe installation of grab rails at a later date			
a. Except for walls constructed of solid masonry or concrete, the walls around the shower, bath (if provided) and toilet should be reinforced to provide a fixing surface for the safe installation of grab rails. Reference: Figure 60, Figure 61 Notes: See Att. 02 – Can be compliant at the CC stage	<input type="checkbox"/>	<input type="checkbox"/>	✓
b. The fastenings, wall reinforcement and grab rails combined must be able to withstand 1100N of force applied in any position and in any direction. Notes: See Att. 02 – Can be compliant at the CC stage	<input type="checkbox"/>	<input type="checkbox"/>	✓
c. The walls around the toilet are to be reinforced by installing: I. noggings with a thickness of at least 25mm in accordance with Figure 6(a); or II. Sheeting with a thickness of at least 12mm in accordance with Figure 6(b). Reference: Figure 59 Notes: See Att. 02 – Can be compliant at the CC stage	<input type="checkbox"/>	<input type="checkbox"/>	✓
d. The walls around the bath are to be reinforced by installing: noggings with a thickness of at least 25mm in accordance with Figure I. 7(a); or II. Sheeting with a thickness of at least 12mm in accordance with Figure 7(b).	<input type="checkbox"/>	✓	<input type="checkbox"/>
e. The walls around the hobless (step-free) shower recess are to be reinforced by installing: I. noggings with a thickness of at least 25mm in accordance with Figure 8(a); or II. Sheeting with a thickness of at least 12mm in accordance with Figure 8(b). Reference: Figure 60 Notes: See Att. 02 – Can be compliant at the CC stage	<input type="checkbox"/>	<input type="checkbox"/>	✓
10. A continuous handrail on one side of any stairway where there is a rise of more than one metre.			
a. Stairways in dwellings must feature: I. A continuous handrail on one side of the stairway where there is a rise of more than 1m.	<input type="checkbox"/>	✓	<input type="checkbox"/>

The references below are to be read as set and referenced in each section of the SEPP 65 Part 4Q1

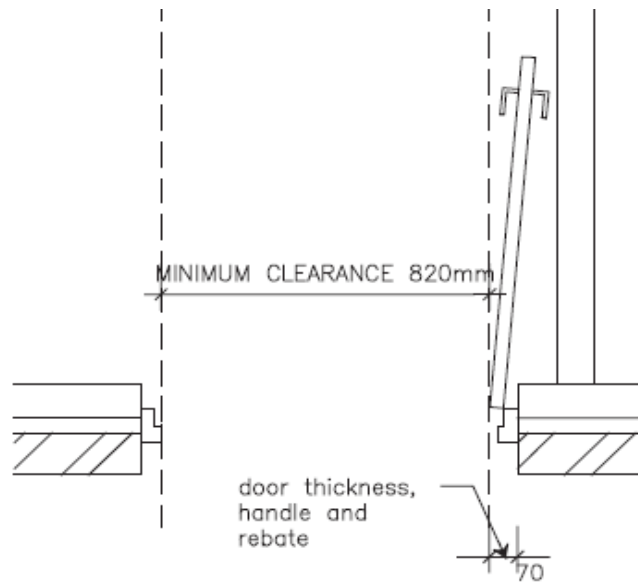

Figure 2(a) Silver level clear door opening

Figure 56

SAI Global Ltd License 1704-c045-2

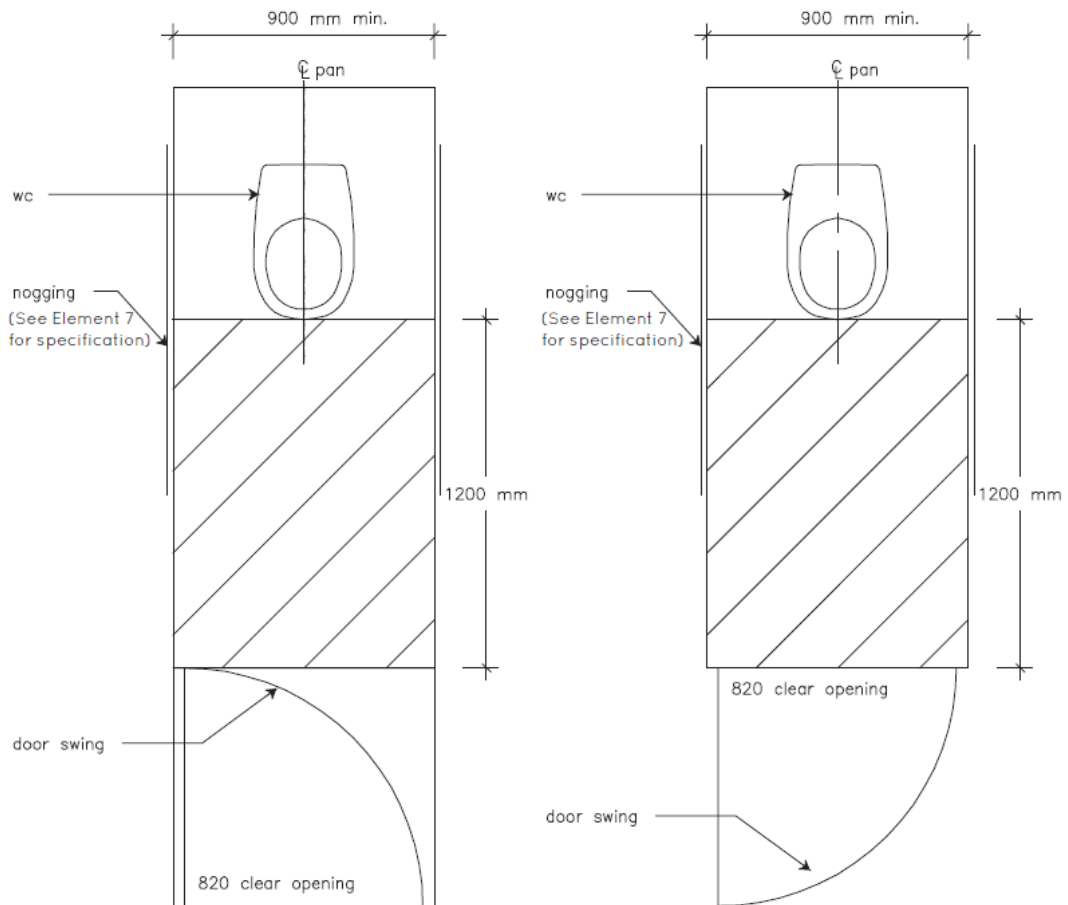

Figure 57

SAI Global Ltd License 1704-c045-2

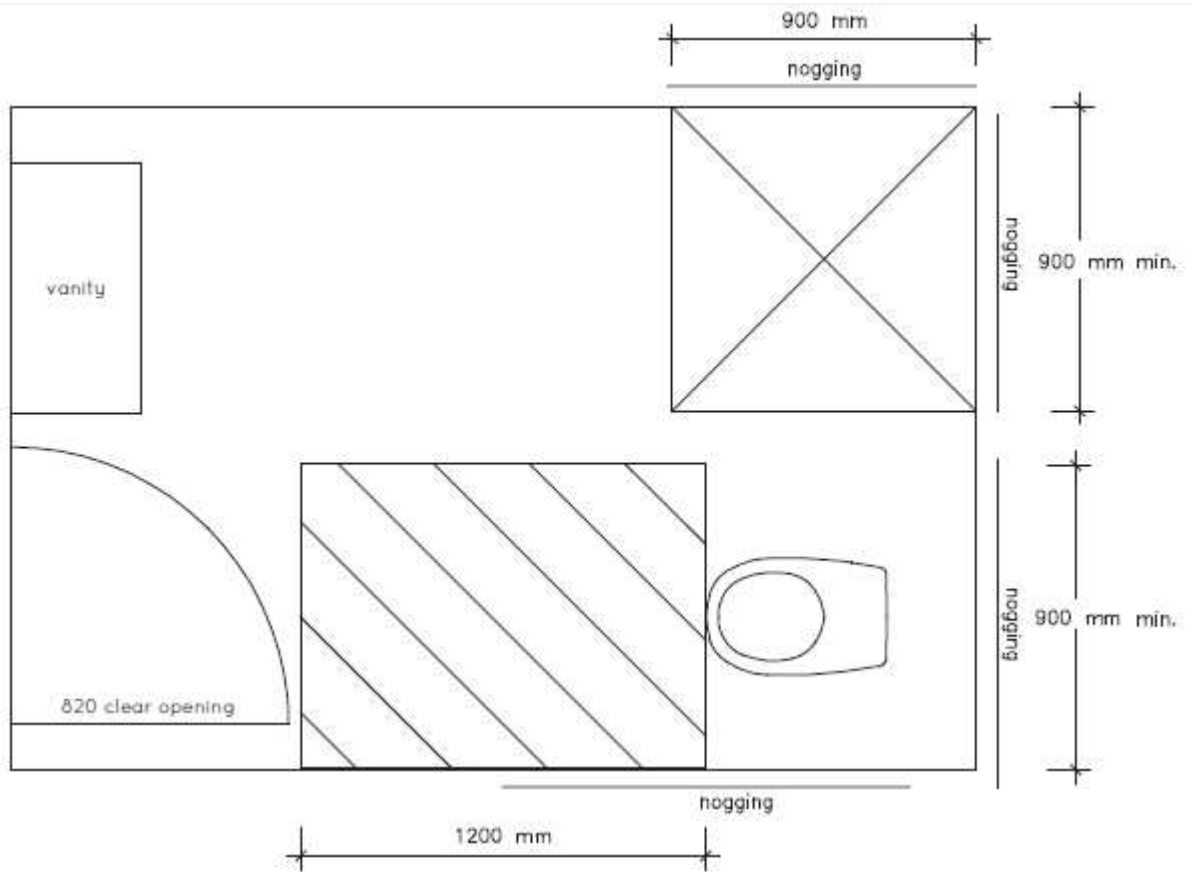
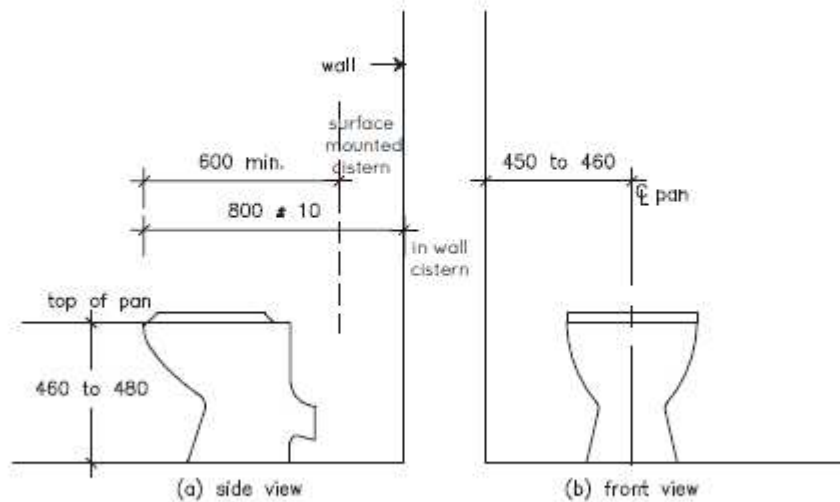

Figure 3(b) Silver level ground (or entry) level toilet layout and space requirements in a combined bathroom.



note: for the purpose of dimensioning, the front of the wc pan has been used as the datum plane
 dimensions in millimetres

Figure 58

SAI Global Ltd License 1704-c045-2

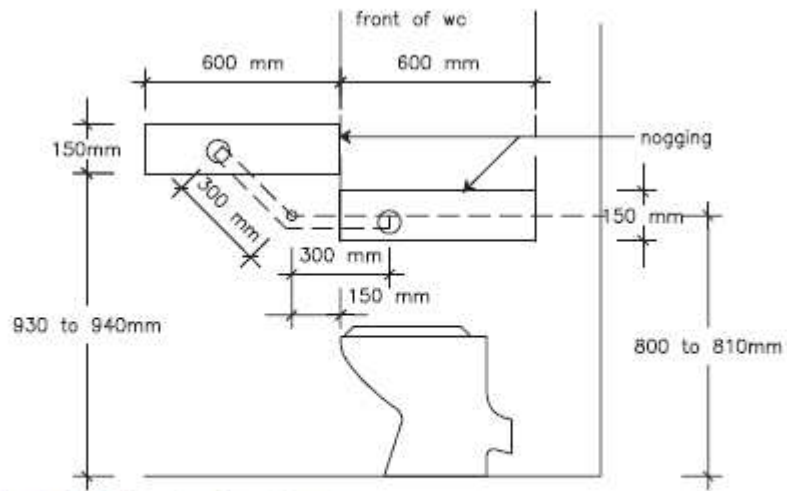

Figure 6(a) Toilet – Location of noggings

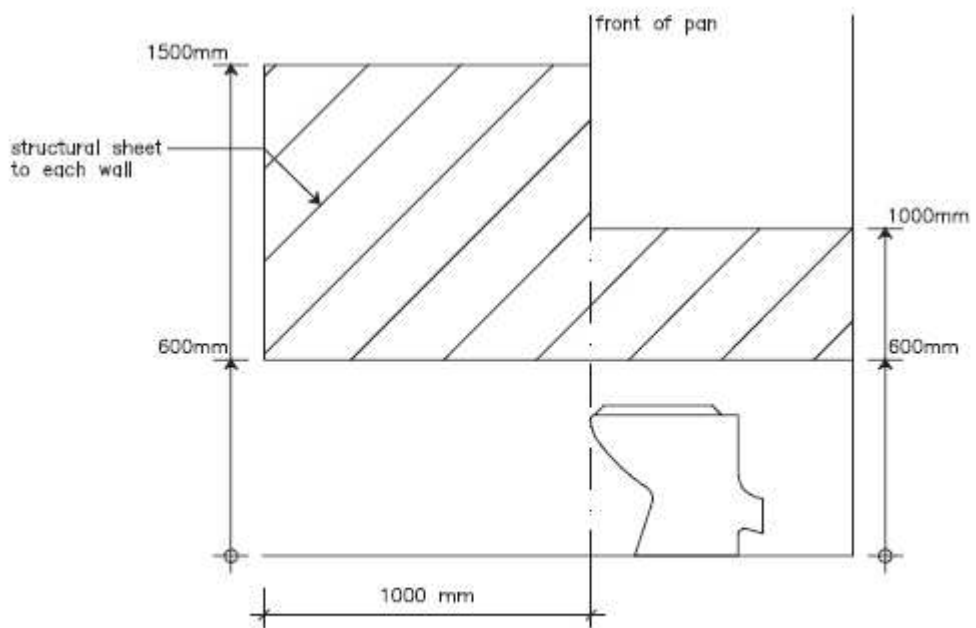

Figure 6(b) Toilet – Location of sheeting

Figure 59

SAI Global Ltd License 1704-c045-2

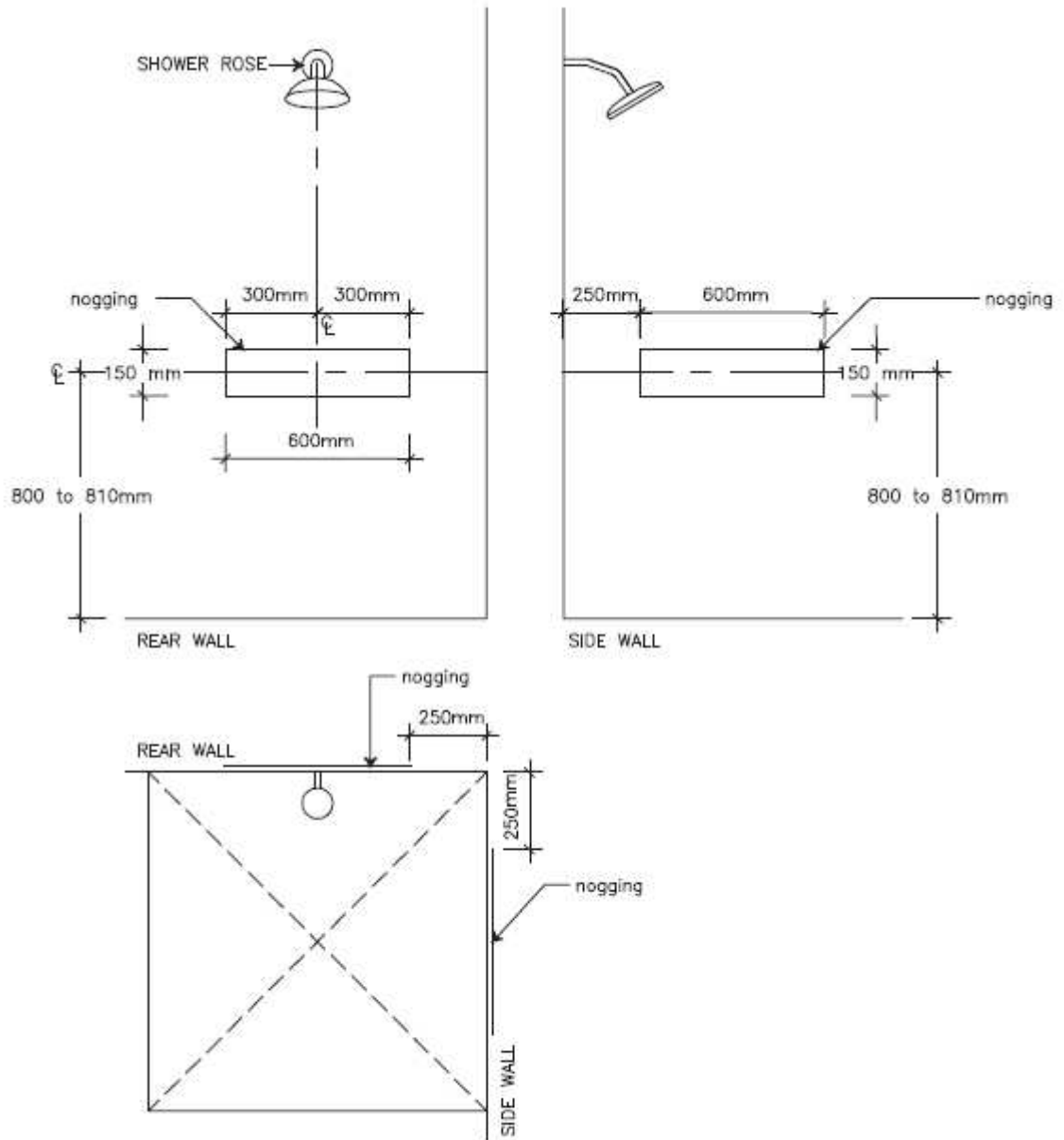

Figure 8(a) Shower recess – Location of noggings

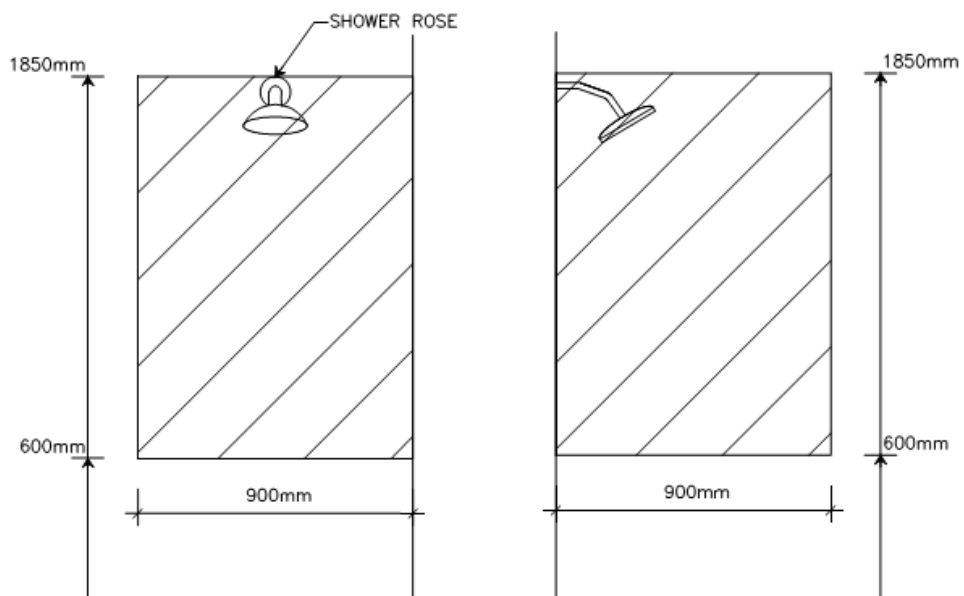

Figure 60

SAI Global Ltd License 1704-c045-2

Advisory Only

The Disability Discrimination Act (1992) (DDA) protects everyone in Australia against discrimination based on disabilities ranging from, but not limited to mobility, sensory and cognitive disabilities. There is no doubt that the introduction of the Premises Standards has led to widespread and important improvements in the accessibility world and safety of all new and upgraded public buildings in Australia.

Section 32 of the DDA makes it unlawful to contravene a provision of a disability standard & the persons responsible who fail to address the 'affected part' requirements when triggered for a building could be subject to a complaint under the DDA as a result.

If there is a difference between the technical requirements of the Access Code and any document referenced in the Access Code, including Australian Standards, the Access Code takes precedence.

The basic trigger for the application of the Premises Standards is when any building work is undertaken that requires building/construction approval. A building certifier, building developer or building manager of a relevant building must ensure that the building complies with the Access to Premises Standards.

The scope of the DDA also includes the area of the room measured within the finished surfaces of the walls and includes the area occupied by any cupboard or other built-in furniture, fixture, or fittings.

The scope of DDA extends beyond the building fabric and includes furniture and fittings. We cannot guarantee or certify DDA compliance because DDA compliance can only be assessed by the court.

People Helping People - PHP



People Helping People, “PHP” is a video interview series hosted by Rami Shakour, founder of Access Link Consulting. The series centers around the vital role of accessibility in enhancing community development and enabling individual independence.

Through enlightening conversations, each episode uncovers how creating accessible environments is not just about compliance with standards, but about fundamentally enhancing people's lives, enabling them to engage fully with their communities and live more independently.

The series features a diverse lineup of guests, including professionals from the fields of construction, architecture, NDIS, as well as individuals who share their personal experiences and the tangible impacts of accessible design. Our conversations delve into innovative solutions and obstacles faced by those working to make our world more accessible, offering insights and inspiration for all listeners. As we explore the stories of individuals from different industry sectors and walks of life, we aim to shed light on the people who are impacting and transforming lives and contributing to a more inclusive community.

Visit our YouTube channel to view our latest interviews.

www.youtube.com/@accesslinkconsulting

Accreditations

“Access Link Consulting was founded to fill a gap in the construction and modern accessibility industry and provide innovation, efficient solutions and proactivity.” – Rami Shakour / Founder



iCIRT

Access Link Consulting is proudly the first access consultancy firm to achieve the esteemed 4-Gold Star iCIRT Rating. The iCIRT Accreditation serves as a testament to our unwavering commitment to professionalism and performance, allowing clients and stakeholders to place their trust in us as a company that upholds the highest standards.



ISO 9001

Quality Management ensures that our processes are structured for efficiency, consistency and continual improvement. It guarantees that our clients receive high-quality, tailored accessibility solutions that meet regulatory requirements and industry best practices.



ISO 45001

Occupational Health & Safety demonstrates our commitment to implementing rigorous health and safety protocols, mitigating workplace risks and fostering a secure environment for our team, clients and stakeholders, ensuring the highest standards of occupational well-being.



ISO 14001

Environmental Management highlights our commitment to environmental management allowing us to minimise our ecological impact and continue to implement sustainable practices throughout our operations.

Partnerships



- Sponsor & Exclusive
Consultancy Partner

Zero Barriers

At Access Link Consulting, our commitment to building inclusive communities shines through our partnership with Zero Barriers, a project by The Multicultural Network. As the exclusive Access Consultancy partner, we combine our accessibility expertise with Zero Barriers' practical community engagement approach. Together, we help businesses adopt inclusive practices, transforming accessibility into a reality for everyone.



SDA Alliance Supporter

Access Link Consulting proudly collaborates with The Specialist Disability Accommodation (SDA) Alliance, dedicated to enhancing SDA across sectors. This partnership brings our accessibility expertise to the forefront of SDA projects. Through advocacy, innovation, and shared values, we aim to create inclusive living environments for people with disabilities, supported by regular collaboration with other providers.



Trademark

Trademark Group is an Australian conglomerate operating in construction, development, and industrial manufacturing. It focuses on fostering collaboration, sharing expertise, and creating cross-border opportunities between Australia, the Kingdom of Saudi Arabia, and the broader GCC region. Access Link Consulting is a proud member of Trademark Group, gaining access to a global network of collaboration and opportunity.

Meet Our Team



Access Link Consulting extends beyond Australia's disability standards for access to premises. We aspire to create a world where dignified and seamless movement is a reality for all, surpassing compliance to achieve comprehensive accessibility solutions for the community.



Rami Shakour

Director

B. Architecture | M.P.M in Construction | Dip. Access Consulting | ACA Accredited Access Consultant | LHA/NCC Accredited Assessor | NDIS Accredited SDA Assessor | Changing Places Assessor

Rami Shakour is the founder and director of Access Link Consulting. With a remarkable track record spanning over 9 years in the accessibility, architecture, and construction industries, Rami brings an unparalleled wealth of expertise to his role as the leader of our consultation services for seamless accessibility facilities.

With Rami's specialised knowledge and forward-thinking approach, Access Link Consulting is uniquely positioned to offer consultation on innovative solutions across residential, commercial, industrial, and mixed-use developments as well as public and private open spaces. By delivering these services, we aim to advance an inclusive and accessible future for all.

Rami holds a Bachelor of Architecture, a Master of Project Management and a Diploma of Access Consulting. In addition to this, Rami is also an Accredited Access Consultant with Association of Consultants in Access Australia (ACAA), National Disability Insurance Scheme (NDIS) Accredited SDA Assessor, LHA/NCC Assessor and Changing Places Assessor.



Tony Walker

Senior Manager

B.LArch (Hons) | Dip. Access Consulting

Tony has developed extensive skills in the planning, design, construction, and management of public open spaces across urban, suburban, and natural landscapes. Previously as the Manager of Fairfield Place and Public Domain Planning for Fairfield City Council and Place Manager East for Parramatta City Council, Tony also developed impressive and outstanding complementary strategic place management and place making project management skills along with valuable community consultation and collaboration experience.

As a Senior Manager, Tony holds a Bachelor of Landscape Architecture (Hons), Dip. Access Consulting, Assoc. Dip. Environmental Control, and a Cert II Horticulture.

With a wealth of qualifications and an extensive skillset cultivated over numerous years of experience in the landscape construction and local government sectors, Tony brings invaluable expertise to Access Link Consulting. His commitment to delivering DDA-compliant outcomes stems from a place-based and community-oriented approach.

Tony's Vision is that public communal spaces which have involved Access Link Consulting, support the provision of dignified and inclusive access to all facilities and amenities including enriching place-based experiences.





Jessica Bechara

Access Consultant

Dip. Business Management | Cert. IV in Access Consulting | ACA Associate Access Consultant

As an experienced Consultant with a wealth of industry insight and experience, Jessica works collaboratively with accredited certifiers, developers, builders and individuals bringing a thorough understanding of both the construction and consultancy realms.

Jessica's expertise encompasses BCA & Access reviews, where she excels in assisting clients in achieving their project goals, from Development Applications to Occupational Certificates. Jessica holds a Certificate IV in Access Consultancy and has over six years' experience in the construction industry. Her extensive experience and first-hand knowledge in accessibility allow her to skillfully coordinate between architects, planners, and developers.

Jessica's dedication to excellence ensures that she delivers quality services to all clients, guided by a vision of accessibility that meets both current and future needs.



Tshkhoun Kechebashian

Account Manager

B. Economics in Management & Accounting | Cert. IV in Bookkeeping

Tshkhoun holds a Certificate IV in Bookkeeping and has extensive work experience, mostly in in-house accounts and administration, including experience in industrial companies.

Her career boasts a diverse range of roles, from General Accounting to Industrial Cost accounting and Human Resources, making Tshkhoun a crucial asset in the day-to-day management of the company. Notably, her involvement in various operational departments and her training in documentation and internal auditing for ISO standards have been pivotal in shaping her career at Access Link.

Drawing from her prior experience in customer service-related positions, Tshkhoun possesses exceptional problem-solving and communication skills, which play a vital role in the seamless management of accounts and related matters.

Tshkhoun considers her customer service experience, bookkeeping and accounting skills and administration expertise a big asset in her career journey.



www.accesslink.com.au

02 7232 0808 | contact@accesslink.com.au

Level 1, Suite 3, 117 Harris St, Pyrmont NSW 2009

P.O Box 123, Gosford NSW 2250

ACCESS LINK
CONSULTING

