

OPERATION & MAINTENANCE MANUAL

Vortceptor





INTRODUCTION

This operation and maintenance manual has been written to assist asset owners and maintenance staff understand how the Vortceptor GPT works, and how to maintain their asset to ensure it performs optimally throughout its life cycle.

The Vortceptor is a vortex type Gross Pollutant Trap that provides robust, high performing, and reliable primary stormwater treatment. It is able to remove litter, sediment, oil, and particulate bound nutrient pollutants out of stormwater. The Vortceptor has no moving parts, which reduces the risk of moving part malfunctions.

It is constructed out of a FRP (fibreglass) body, and 316 stainless steel screens that has been specifically engineered to withstand the tough demands of stormwater and wastewater applications. FRP is resistant to the most demanding of conditions and can exceed the durability of conventional precast concrete and cast in-situ concrete construction.



Manufacture

The Vortceptor is manufactured in Penrith NSW Australia.

Why FRP?

Glass fibre reinforced polymer (FRP) or fibreglass is a composite material of high strength glass fibre reinforcement in a polymer resin matrix. The glass fibres provide the main load bearing function of the material, and can be woven and aligned specifically for strength. Glass fibre reinforcing provides ideal engineering properties of linear elastic behaviour until failure, and extremely high strength that can exceed that of steel in tension. The matrix has 4 important functions: 1. It holds the glass fibre reinforcing in place 2. It transfers forces to and between the fibres, 3. Prevents buckling of the fibres 4. It provides the beneficial protection from the environment. The resin is specifically formulated to ensure resistance to harsh stormwater environments, that can exceed the durability that of concrete.

This material stands up to the harshest environments, commonly found in stormwater, wastewater, acid sulfate soils, and saltwater.

Fibreglass is becoming a material that is enjoying increased adoption in civil structural engineering applications worldwide due to its light weight, high strength, and its ability to resist degradation. The ability of fibreglass to achieve high strength with low weight means that the Vortceptor can be fabricated and delivered to site in a substantially assembled state. The treatment chamber is mostly one-piece, with the other sections being any risers, covers, and a precast concrete diversion chamber. One-piece construction means there are no joints to be made on site for the treatment chamber, which eliminates the potential for leaking joints, and risk of backfill and subgrade degradation from water egress through leaking joints. This means that the Vortceptor will provide a more reliable and watertight body, than one made from precast concrete components that are joined and sealed onsite. This is especially important as joints must be able to withstand tremendous hydrostatic pressures. The Vortceptor takes away this risk by eliminating joints, using a single piece FRP body.

MAINTENANCE



Structural strength of FRP

The Vortceptor has been engineered to withstand the forces associated with structures that are buried and carry vehicular loads. The Vortceptor has been engineered to withstand vehicular loadings to Class D rating per AS3996. A cast in situ concrete cover slab that is 600mm larger than the diameter of the FRP Vortceptor separation chamber, and 200mm thick is required to support a dynamic T44 traffic load. The precast concrete diversion chamber is rated to carry Class D traffic loads without the need for the additional concrete cover slab. Refer to Atlan Stormwater Vertical Tank installation guide for further details.

Safety Precautions

The Vortceptor is an underground structure that retains water. Ensure that adequate safety equipment and procedures are in place to avoid personnel falling into the Vortceptor, as there is a severe risk of drowning.

The Vortceptor is deemed a confined space. It is not necessary to enter the Vortceptor during maintenance, however in the rare event that entry is required, it should only be done so by suitably qualified and equipped personnel, working in accordance with strict OH&S laws, regulations and procedures.

Pollution captured by the Vortceptor can be hazardous to health. Do not make contact with the pollutant material. Ensure personnel are fully equipped with PPE to avoid contact and have procedures in place for first aid.



OPERATION

The Vortceptor is comprised of two chambers: The separation treatment chamber stormwater enters this chamber by being directed by a weir into a chute and is then circulated into the screening area. A vortex flow pattern forms as a result of flow velocity and head. Pollutants are removed via screening, and via centrifugal and gravitational forces acting to separate sediment and other particles.

Pollutants are captured and are stored in a sump area separate to the screening area. The shear cone separates the screening area and the sump, and acts to create quiescent conditions in the sump. This is what allows the Vortceptor to avoid resuspension of captured pollutants. The sump resides directly below the screening area and is conveniently accessible from the manhole for vacuum cleaning.

Storage of pollutants away from the screening area ensures that the Vortceptor can provide a consistent treatment flow rate, that does not diminish according to the level of pollutants stored. This is a key advantage over other GPTs that store pollutants in the screening area.

Floating pollutants are kept at the top of the screening area, but do not impede flow rate. An oil baffle acts to contain oil and hydrocarbons within the treatment chamber. The captured floatable pollution remains inside the Vortceptor until the time it is cleaned.

The vortex action of flow acts to create a shear force across the face of the 316 stainless steel vortex separation screen. The flow is tangential to the screen, which acts to create a self-cleaning effect and prevents the screen from blinding.

Treated flows are then discharged into the diversion chamber via the outlet chute and then discharged from the diversion chamber outlet into the drainage network.

The Diversion Chamber Pit

This chamber allows interface of the Vortceptor with the pipe or culvert drainage network. A weir goes across the width of the Diversion Chamber and is angled so that it is aligned with the entry chute to the separation treatment chamber. The Diversion Chamber is sized to allow bypass of flows exceeding the treatment flow rate over the weir.

Inline Vortceptor models have a small diversion chamber integrated over the separation treatment chamber, to provide a unit that is packaged into a compact footprint.

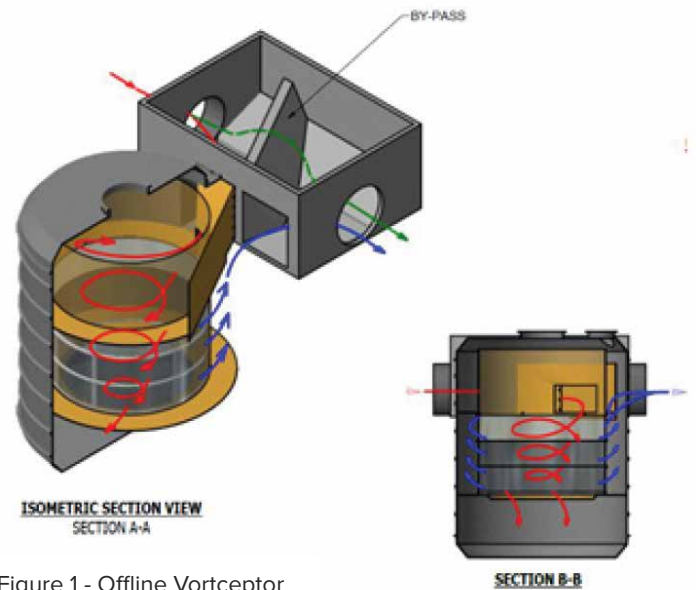

Figure 1 - Offline Vortceptor

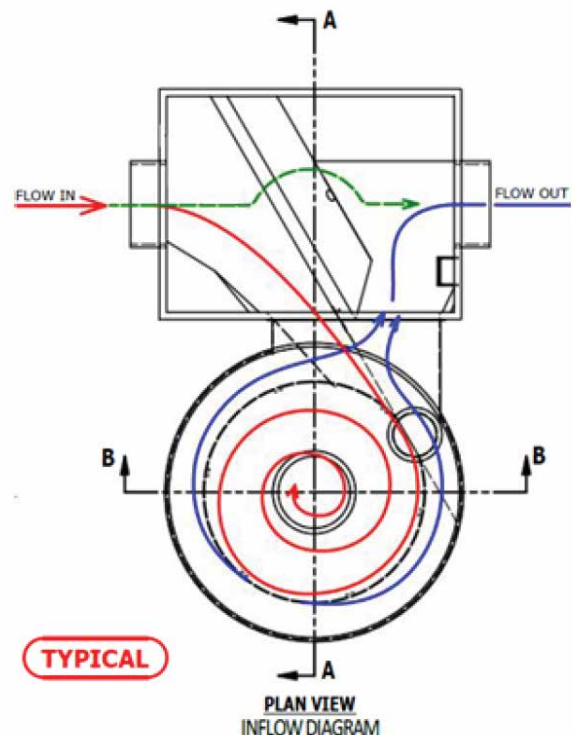

Figure 2 - Offline Vortceptor Plan view showing Separation treatment chamber (Circle) and diversion chamber (rectangle)

Offline and Online

The Vortceptor GPT comes in an offline and online configuration. Offline – the treatment separation chamber is adjacent to the diversion chamber. Online – The diversion chamber and the separation treatment chamber are integrated together.

Cleaning options

The following cleaning options allow asset owners to choose the best option available for ongoing maintenance and the required cleaning frequency with the right cleaning services and resources available.

Depending on the size, access, and depth of the system, the three following methods can be used to clean the Atlan Vortceptor.

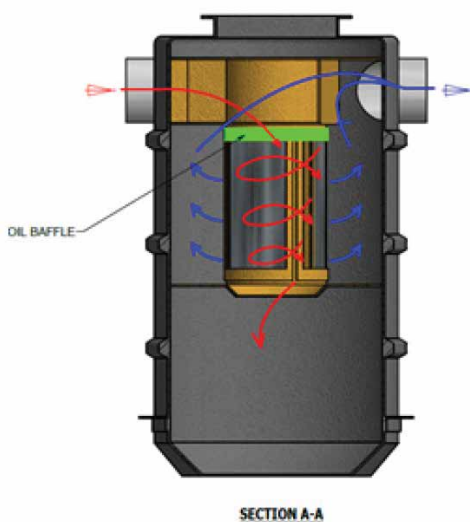

Figure 3 - Online Vortceptor in Elevation view

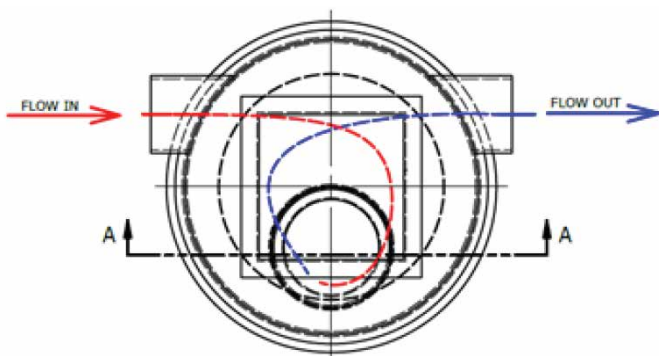

Figure 4 - Online Vortceptor in Plan view showing the diversion chamber and separation chamber in line



Vacuum Suction Cleaning

Equipment needed – eductor truck
Personnel needed – 2

Suction cleaning is used for most proprietary GPT's. This is by far the most convenient and safest method but does require specialist machinery to achieve. There are several specialist companies that offer vacuum suction cleaning of GPTs. Costs are usually based on the total volume of pollutants disposed, as well as water removed. Asset owners should enquire with cleaning contractors if the option to decant captured water back into the Vortceptor is possible, to reduce disposal fees.

Grab Cleaner

Equipment needed – truck with mounted crane and grab attachment
Personnel needed – 1 to 2

The Grab Cleaner can be carried out without dewatering the system. However, this operation is limited to the larger Vortceptor models with larger screen internal diameters. This option is practically only available for the SVO.530 and above as they have screen internal diameters of 2m. Care must be taken by the operator to ensure that the grab does not make contact with the stainless steel screen, and the shear cone underneath the screen area.

The grab truck cleaning option offers the removal of 80 – 90% of the pollution stored in a sump. It can be a cheaper option than vacuum suction cleaning. However, the asset owner must still allow for an annual vacuum clean, to remove accumulated sediment in the sump and behind the screens.

Removable Basket

Truck with mounted crane
Personnel – 1 to 2

If a removal waste basket is fitted, it can be lifted at any time, without the need for dewatering. This is the fastest and the most cost-effective option but comes at the sacrifice of sump capacity. The basket will not impede flow rate.

The smaller sump capacity that results from using a basket may lead to the need for more frequent maintenance activities. But this is offset by the ease and ability to carry out the cleaning activity in house.

An annual vacuum clean to thoroughly dewater and remove accumulated sediment will be recommended for this approach.



Tidal and backwater affected Vortceptors

Gross pollutant traps, including the Vortceptor, may from time to time, be required in tidal and backwater affected locations. The designer should consider specifying a penstock or stop valve on the outlet side of the Vortceptor, so that the Vortceptor can be isolated from tidal and backwater, and effectively dewatered and cleaned. It will be critical for the maintenance crew to re-open the penstock or stop valve after they have finished maintaining the Vortceptor. Failure to re-open the penstock or valve can lead to catastrophic flooding.

Increasing the Vortceptor sump capacity to spread out the cleaning intervals

Vortceptor sump capacities can be increased over and above the standard capacities listed in Table 1 below. It is recommended that the designer carefully estimate the expected pollution load volumes from their catchment and target a sump capacity to match a desired cleaning frequency. Extending the sump is only possible during the desktop design stage, before the Vortceptor is manufactured, so good early planning and design is essential.



Atlan Vortceptor Maintenance Capacities & Dimensions Inline

Models	Dimensions (mm)					Capacities			
	Internal Diameter	Overall Width	Depth Below Invert	Manhole Size (mm)	Max Pipe Size (mm)	Sump Capacity (m ³)	Floatables Volume (m ³)	Treatable Flow Rate (L/s)	Max Flow Rate (L/s)
INLINE SERIES									
SVI.025 (L/R)	1200	1370	1400	600x600	450	1.2	0.06	26	280
SVI.055 (L/R)	1800	1970	1650	900x900	525	2.7	0.22	55	380
SVI.055.M (L/R)	2200	2370	1585		525	3.2	0.22	55	750
SVI.100/15 (L/R)	1500	1670	1900	1000 DIA Internal 600x600	600	3.1	0.20	100	700
SVI.160/22 (L/R)	2200	2370	2400		750	3.4	0.39	160	940
SVI.200/22 (L/R)	2200	2370	2900		750	3.1	0.39	200	990
SVI.300/22 (L/R)	2200	2370	3100		750	4.5	0.83	300	1050
SVI.400/22 (L/R)	2200	2370	3000		750	3.4	0.83	400	1180
SVI.400/25 (L/R)	2500	2670	2900		900	5.5	0.83	400	1650
SVI.400/30 (L/R)	3000	3170	3500		900	10	1.5	400	2500
SVI.500/30 (L/R)	3000	3170	3500		1050	10	1.5	500	1650
SVI.500/35 (L/R)	3500	3670	4000		1050	10	1.5	500	1900



Atlan Vortceptor Maintenance Capacities & Dimensions Offline

Models	Dimensions (mm)				Capacities			
	Internal Diameter	Overall Width	Depth below invert	Manhole Size (mm)	Sump Capacity (m ³)	Floatables Volume (m ³)	Treatable Flow Rate (L/s)	Bypass Flow Rate (L/s)
OFFLINE SERIES								
SVO.096 (L/R)	1500	1670	1725	1000 DIA Internal 600x600	2.0	0.35	96	PROJECT SPECIFIC DESIGN
SVO.140 (L/R)	1500	1670	2025		2.3	0.35	140	
SVO.180 (L/R)	1500	1670	2325		3.0	0.35	180	
SVO.220 (L/R)	2200	2350	2800		4.5	1.1	220	
SVO.360 (L/R)	2200	2350	3080		6.0	1.1	360	
SVO.530 (L/R)	3000	3150	3200		8.5	2.8	530	
SVO.800 (L/R)	3000	3150	4200		8.5	2.8	800	
SVO.810 (L/R)	4000	4150	3400		19.3	5.65	800	
SVO.1200 (L/R)	4000	4150	4000		19.3	5.65	1200	
SVO.1600 (L/R)	4000	4150	4600		19.3	5.65	1600	

Maintenance

The Atlan Vortceptor requires regular inspections and cleaning. There are no consumable parts on the Atlan Vortceptor throughout its operating life. The regularity of inspections and cleaning of the Vortceptor is contingent on the features and properties of the catchment area. Good monitoring and record keeping systems by the asset owner will allow them to optimally schedule cleaning activities for each individual Vortceptor. The section below provides asset owners some guidance to the frequencies for maintaining the Vortceptor.

Inspection

Routine inspection is the key to effective maintenance. Pollutant transportation and deposition may vary from catchment to catchment. Regular routine inspections will help the asset owner assess the rate of pollutant capture for that specific location.

At a minimum, routine inspections should be performed twice per year. The suggested inspection frequency in the first year of operation is 3 months.

This interval can be extended to 6 months at the discretion of the asset owner. The routine visual inspection should ascertain that the system components are in working order and that there are no blockages or obstructions in the inlet, outlet, and separation screen. The routine inspection should also quantify the accumulation of floating trash, and sediment in the sump. Measuring pollutant accumulation can be done with a calibrated dipstick, tape measure or other measuring instrument. All inspections should be recorded. A sample inspection report is attached to this manual. Furthermore, it is recommended that the Vortceptor be inspected after every major rain event, with a focus on ensuring there are no blockages to the inlet and outlets of the Vortceptor and the diversion chamber.

Access for maintenance

Separation Treatment chamber

The separation treatment chamber has adequate access for maintenance. Vortceptor models up to SVO.360 have single manhole access, whereas the larger Vortceptor models SVO.530 and above have 2 manholes, consisting of Class D cast iron lids. The lid in the centre of the separation chamber provides access into the screen and sump area.

The single round lid as pictured below provides access behind the screen, so that sediment can be extracted using a vacuum.

The lids are locked with bolts. The lids can be lifted using standard manhole cover lifters.

As described above, an additional Class D manhole cover allows access to the clean water side of the screen, or otherwise called the area 'behind the screen'. This area can have some level of sediment deposition over time. This manhole allows convenient access, by allowing the vacuum hose to be dropped down vertically to the area behind the screen. It is recommended that the area behind the vortex separation screen be cleaned annually, to avoid build-up of sediment. Alternatively, access behind the screen can be gained by inserting the vacuum hose from the outlet side of the diversion chamber, and into the outlet of the separation treatment chamber.



Diversion chamber

There are access manholes above the diversion chamber, with a lid situated either above the inlet side and/or the outlet side of the chamber.

These manholes allow for visual inspection to the treatment chamber inlet and outlet chutes, and if required, access for cleaning.

Access for Maintenance

Pollution removal performance will not be impacted until 100% of the sump capacity is exceeded however it is recommended that the system be cleaned prior to reaching maximum sump capacity for easier removal of sediment. The level of sediment is easily determined by measuring from the finished surface level down to the top of the sediment pile. To avoid underestimating the level of sediment in the chamber, the measuring device must be lowered to the top of the sediment pile carefully. Particles at the top of the pile typically offer less resistance to the end of the rod than consolidated particles toward the bottom of the pile.

Method to calculate the % sump capacity filled with pollutants

1. Determine the water depth that is above the sediment layer. This is done by taking two measurements with a measuring staff: one measurement from the finished surface level (ie manhole opening level) to the top of the sediment pile and the other from the manhole opening to the water surface.

2. If the difference between these measurements is less than the Depth from water level to top of sump in table 2, the system should be cleaned out. If the water depth to the sediment is less than the water depth to the top of sump, this means the sediment level is above the sump.

3. If the water depth to sediment is greater than the depth from water level to top of sump, calculate the % of sump that contains sediment by the following method:

$$\text{Height of sediment} = \text{Depth of Water level to top of sump} + \text{Sump depth} - \text{water depth to sediment}$$

$$\text{Sump \% full} = \text{height of sediment} / \text{height of sump} \times 100$$

A work sheet is attached to the end of this manual to assist with calculating and recording the sump levels.

Models	Sump depth (mm)	Depth from Water level to top of sump	Sump Capacity (m ³)	Light Liquid Volume (L)	Floatables Volume (m ³)
INLINE SERIES					
SVI.025	25	1400	500	600	770
SVI.055	55	1650	700	800	770
SVI.055.M	55	1585	700	800	770
OFFLINE SERIES					
SVO.096	1150	1010	2.0	239	0.39
SVO.096	1320	1260	2.3	239	0.39
SVO.096	1380	1560	2.5	239	0.39
SVO.096	1430	1560	4.3	515	1.1
SVO.096	1570	1860	6.0	515	1.1
SVO.096	1270	1860	8.5	1263	2.8
SVO.096	1270	2860	8.5	1263	2.8
SVO.096	1540	1860	19.3	2155	5.65
SVO.096	1540	2490	19.3	2155	5.65
SVO.096	1560	3150	19.3	2155	5.65

Table 2 - Sump depth dimensions

Cleaning

Cleaning of the Vortceptor system should be done during dry weather conditions when little or no flow is entering the system. The use of a vacuum truck is generally the most effective and convenient method of removing pollutants from the system. Simply remove the manhole covers and insert the vacuum hose into the sump.

The system should be completely drained down and the sump fully evacuated of sediment, and a final hose down of the screen and sump.

Disposal of material

The material captured by the Vortceptor could include hazardous material, such as syringes, chemicals, and sharp objects. Care must be taken by cleaning crews and they must work in accordance with a specific job safety plan. PPE such as gloves, protective wear, boots should be mandatory. Disposal of material must be done in accordance with all environmental regulations. In many jurisdictions, disposal of the sediments may be handled in the same manner as the disposal of sediments removed from catch basins.

Inspection and cleaning frequencies

The frequency of cleaning will depend on the pollutant loads of the catchment, so inspections are recommended to confirm the maintenance intervals, which could be either three, six or twelve months.

Visual inspection and cleaning frequencies

	After every major storm	3 months	6 months	12 months
Visual inspection of treatment chamber	-	visually inspect every 3 months. Measure the amount of pollutants in the sump	-	-
Visual inspection of diversion chamber	Check inlet and outlet pipe or culvert for blockages	-	Visually inspect the diversion chamber for any signs of blockage and sediment build up	Visually inspect the diversion chamber for any signs of blockage and sediment build up
Regular Clean – Removal of captured pollutant material from the Vortceptor separation chamber	-	-	-	-
-	-	-	Primarily to remove floatables and sump contents contents. Note Cleaning interval is every 6 months on average but may need to be adjusted according to site specific conditions. Interval frequency can be reduced if extended sump has been installed	-
Full dewater and clean	-	-	-	Full sump pump out, jet screen and sump
Clean behind screen	-	-	-	In conjunction with full dewater and clean
Visual inspection of Vortex separation screen	-	-	-	Note the condition of the screen – note down signs of damage if any
Clean diversion chamber	-	-	Visual inspection	Remove sediment buildup if required.

Repairs and replacement

The Vortceptor does not have any consumable parts that require replacement throughout its design life of the unit. However, in the unlikely event that the Vortceptor requires repair due to damage, the following provides guidance on repairing the Vortceptor.

All repairs should be conducted by suitably qualified personnel, following OH&S requirements for working in confined spaces. All repairs should be conducted in dry weather and should be conducted after the Vortceptor has been dewatered and emptied.

Vortex Separation Screen

The vortex separation screen is comprised of 316 stainless steel. The Screen is not a consumable item. In the unlikely event that the screen is damaged, specific sections of the screen can be removed by cutting them out. Replacement screens can be riveted into the fibreglass body, and tack welded to the neighbouring screens. The installer must ensure that the screen is installed such that the screen aperture is facing the correct direction.

The way to check this is to run a hand over the surface of the screen. Ensure you are wearing gloves. The screen is smooth when stroking in one direction, and rough when stroking in the opposite direction. The smooth direction indicates the direction that the vortex will flow. Ensure that the replaced screen is in the same direction as of the screens next to them. Replacement screens are available from Atlan Stormwater, as well as specialist on site support from Atlan Stormwater's maintenance team.

Shear cone

The shear cone is not a consumable item. The only practical way it will be damaged is if a grab makes contact. Vortceptors up to SVO.360 have FRP shear cones, and the units from SVO.530 and above have 316 stainless steel shear cones. Replacement of the shear cone has been designed for easy replacement.

First completely dewater the unit, then gain access, noting that it is a confined space. Undo bolts and replace the damaged shear cone section. The shear cone is divided into 4 separate

sections, so that only the damaged section needs to be replaced. Replacement shear cone sections are available from Atlan Stormwater as well as specialist on site support from Atlan Stormwater's maintenance team.

Cast iron Manhole covers

Cast iron manhole covers are not consumable items. However in the event they are damaged, they are readily available on the market as standard covers are used for the Vortceptor.

Precast concrete Diversion chamber

The diversion chamber is made of min 40Mpa concrete. Damage or cracks can be repaired with a concrete mortar such as Rapidset, Xypex, Parchem. 2-part epoxy and flexible fillers such as Sikaflex are also widely available. Refer to the manufacturers for specialist details on repairing precast concrete for water retaining structures.

Fibreglass components

One of the many benefits of using FRP/fibreglass over conventional materials such as concrete is its ease and durability of repairs. The material to repair fibreglass is readily and widely available.

Safety

Ensure the work area is well ventilated as the resin fumes can be harmful, especially in a confined space area. Resins, acetone, and FRP dust are flammable. Peroxides (catalyst) are strong oxidizing agents and can ignite fuels. Follow MSDS instructions, including PPE prior to commencement of repair work.

Repairs to Fibreglass

A key principle of repairs to fibreglass is that the repair will differ from the original fibreglass primary structure. The original resin and glass reinforcing fabric in the primary structure has cured and bonded chemically and physically with each other, forming the primary bond. Repairs to a damaged fibreglass part is referred to as secondary bonds, that are attached to the primary structure. The repair relies on the physical bond to the primary structure, and the resin must have strong adhesive properties. Increasing the surface area of the bond to the primary structure will increase the strength and durability of the repair.

Parts for repair

1. Resin – Polyester resin or Vinyl ester resin
2. Catalyst / Hardener – MEKP (Butanox M50 or equivalent)
3. Fibreglass matt – 450g/m² chopped strand mat
4. Acetone – for cleaning the bond surface
5. Hot Coat – finishing layer (resin mixed with 1% solution of 8% wax in styrene can be used for this purpose)
6. Paint brush and or roller – for applying resin to fibreglass mat

Commercial fibreglass repair kits are widely available and can be used to repair the Vortceptor.

Identify the Damaged Area

Identify the damage and draw the boundary of the damage. An easy inspection method is to tap a solid material, like a coin, and listen for any differences in the sound of the tap. Mark out suspect areas. Damage could be cracks, holes, puncture, and delamination.

Trimming and cutting

Cut out the damaged area if you cannot patch over the area. Otherwise grind the surface as described below. Most concrete or masonry cutting tools are compatible to cut FRP. Note that high speed cutting tools for metals are not suitable for FRP.

Surface cleaning and grinding

Grind approximately 20mm or more of surface area from the damaged area to promote adhesion of the repair. Grind surface using abrasive methods.

Recommended equipment are 4 inch grinder with 34 grit sanding disc, or an orbital sander with a low grit number such as 60 grit. Do not use chemical primers. Grind the surface until the glossy finish of the resin is no longer visible, surface is even and uniform with no high or low spots. A slight taper in the surface will assist with locking in the repair.

Clean the surface of dust, water, oil. Brush or vacuum to remove dust, then wipe the surface with clean acetone. The surface should not be wet and must be dried.

The surface must be prepared again if the repair has not been performed within 24 hours of the surface preparation, or if the surface is contaminated with oil or water.

Resin preparation

Mix resin and catalyst in small batches. Catalyst should be between 1.25% to 2.5% of the resin weight. The reaction of the resin and catalyst will cause high amount of heat when curing. Refer to the resin and catalyst manufacturer's instructions.

Applying Fibreglass layers

Wet the bonding surface with catalysed resin. Apply fibreglass mat in layers, and completely cover with resin. Minimise the layer thickness to no more than 7mm, to avoid generating excess heat. Build up the layers until it matches or exceeds the thickness of the primary structure. Press the layers together to avoid the formation of air pockets between the layers, by using a roller.

Finishing the Fibreglass repair

After all layers are applied, a final coat of 'Hot Coat' is to be applied. The Hot coat can be applied while the top layer is still wet.

Further Assistance

Thank you for choosing the Atlan Vortceptor GPT. We are confident that it will faithfully carry out the essential task of keeping our waterways clean of pollution and do so in a robust and hassle-free manner for years to come. Our confidence in the product is backed by our 25 year warranty. Engineering and maintenance support are at hand for all asset owners. Contact Atlan Stormwater on 1300 773 500 or email maintenance@atlan.com.au.



Inspection & Maintenance Log

Model _____ Location _____

Date	Depth from manhole to top of sediment (1)	Depth from manhole to top of water level (2)	Water depth to sediment (1) – (2) (3)	Water Depth top of sump (from table 2) (4)	Is the water Depth (3) less than water depth to sump (4) Yes/No If yes, organize clean	% sump capacity full	Describe Maintenance Performed	Comments

a. The water depth to sediment is determined by taking two measurements with a measuring staff: one measurement from the manhole opening to the top of the sediment pile and the other from the manhole opening to the water surface.

b. Obtain the Water depth to top of sump for the specific Vortceptor model from table 2 of this manual

c. Compare the Water Depth to Sediment (3) to the Water Depth to top of sump (4). If the water depth to the sediment is less than the water depth to the top of sump, this means the sediment level is above the sump.

d. If the water depth to sediment is greater than the depth from water level to top of sump, calculate the % of sump that contains sediment by the following method:

Height of sediment = Depth of Water level to top of sump + Sump depth - water depth to sediment
 Sump % full = height of sediment / height of sump x 100

e. For optimum performance, the system should be cleaned out when the floating hydrocarbon layer accumulates to an appreciable

Ecoceptor 6000 SERIES

SELECTION CHART

Weight approximately 700kg each

MODEL	E/606767	E/607575	E/609090
Inlet (mm)	675	750	900
Outlet (mm)	675	750	900
Invert Level* (mm)	1400	1400	1400
Overall Height* (mm)	3300	3300	3300
Internal Diameter (mm)	2200	2200	2200
Manhole Opening (mm)	900 x 600	900 x 600	900 x 600
Manhole Quantity	1	1	1
Max Silt Capacity (Litre)	6000	6000	6000
Max Hydrocarbon Capacity (Litre)	2200	2200	2200
Max Capacity (Litre)	11500	11500	11500

Atlan Stormwater accepts no responsibility for any loss or damage resulting from any person acting on this information. The details and dimensions contained in this document may change, please check with Atlan Stormwater for confirmation of current specifications.

*Height does not include lid.

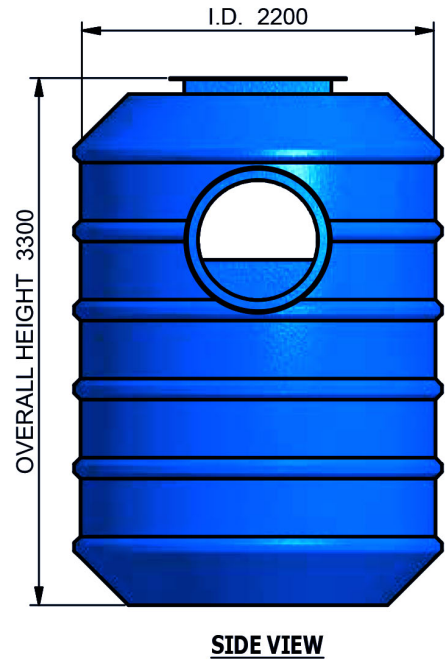
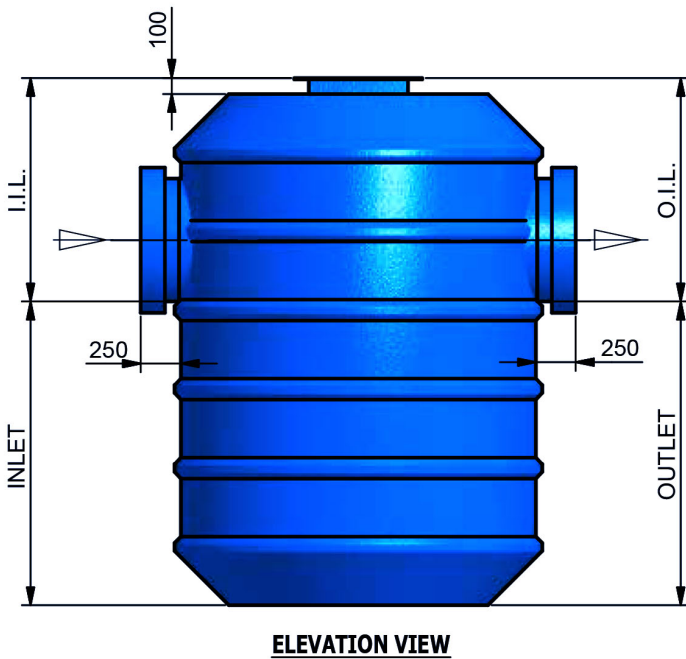
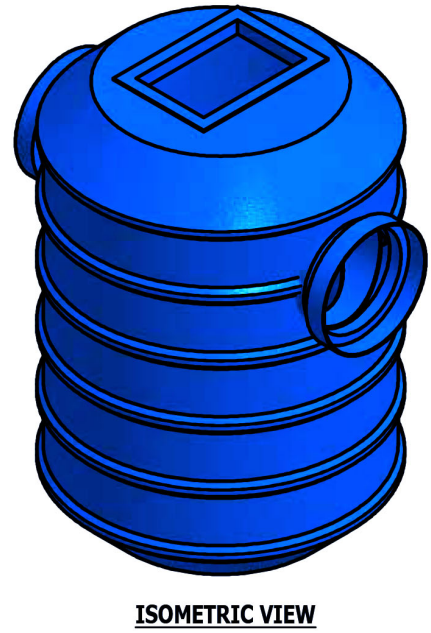
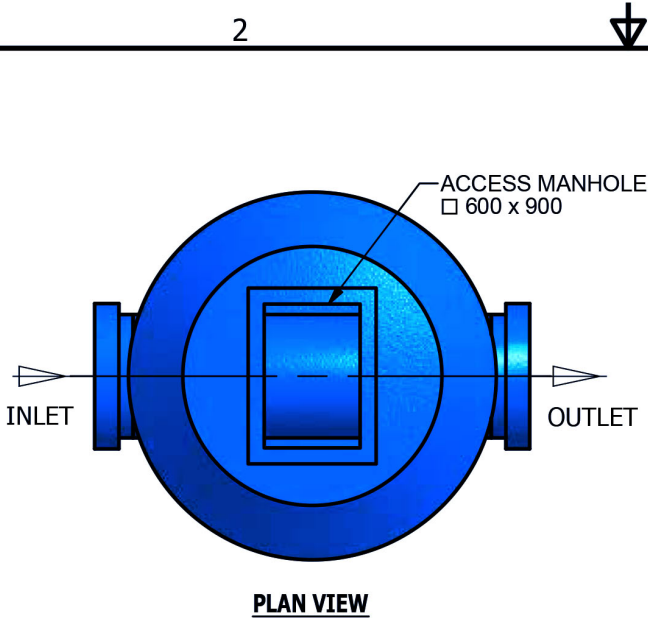

TOLERANCE: ALL DIMENSIONS 10mm UNLESS OTHERWISE STATED.

ALL INTERCONNECTING PIPEWORK, PITS AND ASSOCIATED DRAINAGE BY OTHERS

Drawn P.Z.	Date 10-10-17
Check	Date
Verified	Date
Approved	Date
Request No. RN4656	

Atlan
STORMWATER

P 02 8705 0255 sales@atlan.com.au
100 Silverwater Rd,
Silverwater NSW 2128
atlan.com.au

PRODUCT : 6000 SERIES			
TITLE			
SCALE N.T.S	SIZE 1	SHEET 1	REV 1
CUSTOMER CODE :		DWG No. SP17-EC39300-P	

C:\Vault\Working\Folder\Designs\SP17\PRODUCTS\RECEPTOR\6000 Series\SP17_EC39300-P.IDW

Ecoceptor 8000 SERIES

SELECTION CHART

Weight approximately 1350kg each

MODEL	E.175.105105	E.185.135135	E.200.150150	E.8018090.BC
Inlet (mm)	1050	1350	1500	1800x800 BC
Maximum Treatment Flow (lps)	1750	1850	2000	-
Outlet (mm)	1050	1350	1500	1800x800 BC
Invert Level* (mm)	2400	2400	2400	1800
Overall Height* (mm)	4500	4500	4500	4500
Diameter (mm)	2480	2480	2480	2480
Manhole Opening (mm)	900 x 600	900 x 600	900 x 600	900 x 600
Manhole Quantity	2	2	2	2
Max Silt Capacity (Litre)	10,000	10,000	10,000	10,000
Max Hydrocarbon Capacity (Litre)	4200	4200	4200	4200
Max Capacity (Litre)	19,000	19,000	19,000	19,000

Atlan Stormwater accepts no responsibility for any loss or damage resulting from any person acting on this information. The details and dimensions contained in this document may change, please check with Atlan Stormwater for confirmation of current specifications.

*Height does not include lid.

2



1

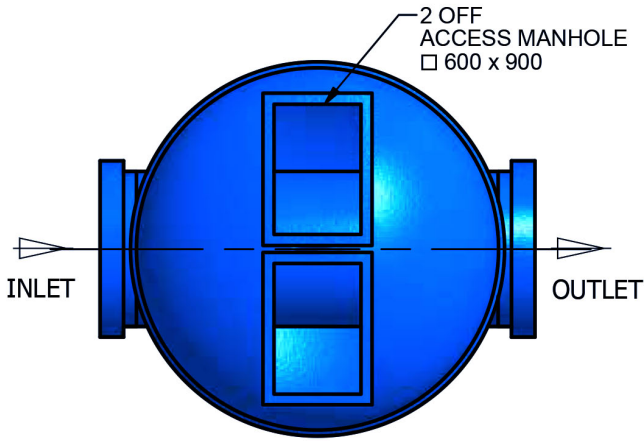

PLAN VIEW

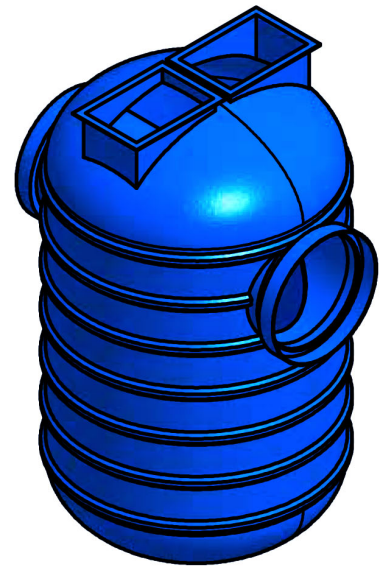

ISOMETRIC VIEW

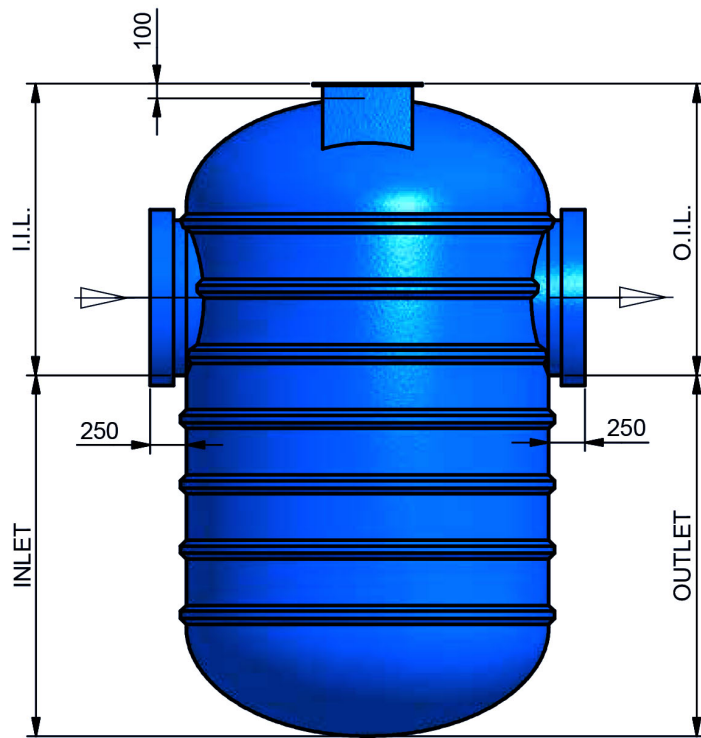

ELEVATION VIEW

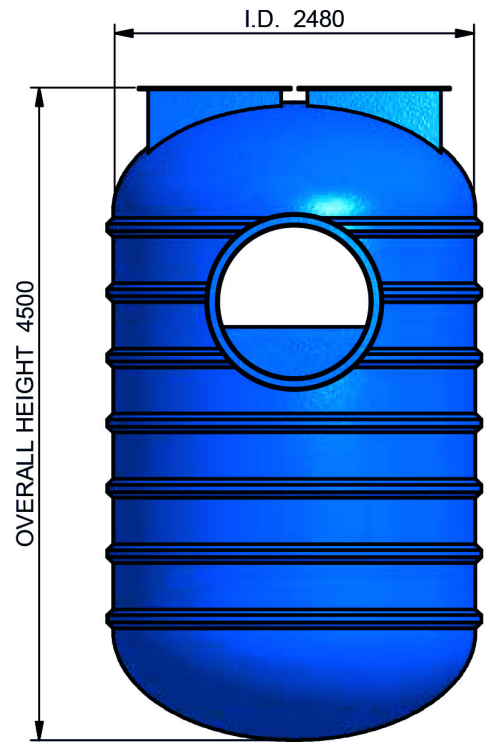

SIDE VIEW

TOLERANCE: ALL DIMENSIONS 10mm UNLESS OTHERWISE STATED.

ALL INTERCONNECTING PIPEWORK, PITS AND ASSOCIATED DRAINAGE BY OTHERS

Drawn P.Z.	Date 22-03-18
Check	Date
Verified	Date
Approved	Date
Request No. RN1801	



P 02 8705 0255 sales@atlan.com.au
 100 Silverwater Rd,
 Silverwater NSW 2128
 atlan.com.au

PRODUCT :			
8000 SERIES			
TITLE			
SCALE N.T.S	SIZE 1	SHEET 1	REV 1
CUSTOMER CODE :		DWG No. SP18-EC10590-P	

2



1

C:\Vault Working Folder\Designs\SP18\PRODUCTS\ECOCEPTOR\8000 Series\SP18 BROCHURE DRAWING\SP18-EC10590-P.dwg

Joy in water

'We believe clean waterways are a right not a privilege and we work to ensure a joy in water experience for you and future generations.'

Andy Hornbuckle



Atlan
STORMWATER

P 02 8705 0255
sales@atlan.com.au
100 Silverwater Rd,
Silverwater NSW 2128
atlan.com.au