



Access Assessment Report

Erection of a mixed-use development

194 Oxford Street and 2 Nelson Street, Bondi Junction

Date: 10/03/2025



Report no. Q240186- ACC

Client: Star Gate Property

Prepared by: Jazmyn Stol

ABN: 33 643 504 867

DOCUMENT CONTROL

Report no.	Date	Status
Q240186 - ACC	10/03/2025	V7 - Final
		<p>Prepared by:</p>  <p>Jazmyn Stol</p> <p>Diploma of Access Consulting Completed. Associate Member of ACAA: Member 715</p> 

CONTENTS

Table of Contents

Date: 07/02/2025	1
Report no. Q240186-ACC	1
Client: Star Gate Property	1
Prepared by: Jazmyn Stol	1
ABN: 35 648 658 566	1
Executive Summary	4
1 Introduction	5
1.1 Location and Description	5
1.2 Purpose of the Report	5
1.3 Building Code of Australia.....	5
1.4 Limitations of the Report.....	5
1.5 Federal Disability Discrimination Act (DDA).....	6
1.6 Disability (Access to Premises - Buildings) Standards 2010.....	6
2 Key compliance considerations	6
2.1 BCA Accessibility Provisions.....	6
2.2 Development Consent Conditions	7
3 Access Compliance Matters to be Addressed	8
Annexure A – Detailed BCA Access Assessment.....	13
Annexure B – Design Documentation.....	49

Executive Summary

This report provides an Access assessment of erection of a mixed-use development. The architectural design plans have been assessed against the following–

- the accessibility provisions of the Building Code of Australia 2022;
- the Disability (Access to Premises – Buildings) Standards 2010, including the Access Code;
- the access-related conditions of the Development Consent (excluding conditions relating to Adaptable Housing, which will be addressed by a separate Access Consultant); and
- the Livable Housing Design Guidelines 4th Edition silver level universal design features.

The design was found to be consistent with the relevant access provisions, subject to only minor amendments and compliance with specific accessibility requirements that are not detailed on the plans, as outlined in Part 3 of this report 'Access Compliance Matters to be Addressed'.

1 Introduction

1.1 Location and Description

The development is located at 194 Oxford Street and 2 Nelson Street, Bondi Junction

The work involves:

1.2 Purpose of the Report

The purpose of the Report is to provide an assessment of the proposed works, as detailed on the architectural design plans, against the relevant accessibility provisions of the following:

- the deemed-to-satisfy provisions of the current Building Code of Australia 2022;
- the Disability (Access to Premises – Buildings) Standards 2010, including the Access Code;

The report intent is to clearly outline those areas where compliance is not achieved and provide recommendations to achieve compliance.

1.3 Building Code of Australia

This report is based on the accessibility provisions of the National Construction Code 2022, Volume One, Building Code of Australia.

1.4 Limitations of the Report

This report does not include, nor imply compliance with:

- a) The Disability Discrimination Act (it cannot be guaranteed that that a complaint under the DDA will not be made, however should the building comply with the requirements of the Disability (Access to Premises – Buildings) Standards 2010 (as per the BCA accessibility provisions detailed in this report) then those responsible for the building cannot be subject to a successful complaint);
- b) Buildings) Standards 2010 (as per the BCA accessibility provisions detailed in this report) then those responsible for the building cannot be subject to a successful complaint);
- c) requirements of Australian Standards unless specifically referred to;
- d) requirements of other Regulatory Authorities including, but not limited to, Telstra, Telecommunications Supply Authority, Water Supply Authority, Electricity Supply Authority, Work Cover, Roads and Maritime Services
- e) (RMS), Local Council, Department of Planning and the like;
- f) conditions of Development Consent not related to access for people with a disability; or
- g) compliance with AS 4299-2005 for the design of the Adaptable Housing units.

1.5 Federal Disability Discrimination Act (DDA)

Disability is broadly defined and includes disabilities which are physical, intellectual, psychiatric, neurological, cognitive or sensory (a hearing or vision impairment), learning difficulties, physical disfigurement and the presence in the body of disease-causing organisms.

All organisations have a responsibility, under the DDA, to provide equitable, dignified access to goods and services and to premises used by the public. Premises are broadly defined and would include all areas included within the subject development.

The DDA applies nationally and is complaint-based. While the Disability (Access to Premises – Buildings) Standards 2010 and the BCA2022 are recognised as a design standard to satisfy certain aspects of the DDA, compliance with the BCA2022 and the referenced standards does not guarantee that a complaint will not be lodged.

1.6 Disability (Access to Premises - Buildings) Standards 2010

The aim of the Disability (Access to Premises – Buildings) Standards 2010 (Premises Standards) is to provide the building and design industry with detailed information regarding the required access provisions associated with the design and construction of new buildings and upgrade to existing buildings.

The Premises Standards intend to provide certainty for the building industry in relation to meeting the requirements for access in new and upgraded buildings. They only apply to elements addressed within the Standards. All other elements related to premises will still be subject to the existing provisions of the DDA.

For existing buildings that are undergoing alterations or extensions (referred to as a 'new part'), the Premises Standards introduce the concept of upgrade of the 'affected part'. An affected part being:

- (a) the principal pedestrian entrance of an existing building that contains a new part; and
- (b) any part of an existing building, that contains a new part, that is necessary to provide a continuous accessible path of travel from the entrance to the new part.

This means that in many instances, the new works will need to be connected to the building's principal pedestrian entrance by an accessible path of travel, meaning that upgrade to a building may be necessary even where none was proposed.

As the development the subject of this report involves the construction of a new building, the Premises Standards will apply to the building, however compliance with the Premises Standards (including the Access Code) will be achieved by complying with the accessibility provisions of the BCA, as detailed in this report.

2 Key compliance considerations

2.1 BCA Accessibility Provisions

The architectural design documentation has been assessed against the accessibility provisions of the BCA, including Part D4, Clause E3D8 and Clause F4D5. It is noted that compliance with these BCA provisions will also achieve compliance with the Access Code under the Premises Standards.

The building has been classified according to its use, in accordance with BCA Clause A6.0, as follows:

Class	Level	Description
7a	Basement 1-4	Carpark
2	Building A Level 1- 13 Building B Level 1- 16	Units
6	Ground floor	Retail
10b	Level 1	Swimming pool

A detailed assessment of the design against the relevant BCA accessibility requirements is provided in Annexure A of this report.

2.2 Development Consent Conditions

A detailed assessment of the design against the conditions of the Development Consent relating to access for people with a disability is provided in Annexure B of this report.

3 Access Compliance Matters to be Addressed

As identified by the clause-by-clause assessments contained in Annexures A of this report, the following compliance matters will require further design input and/or will need to be addressed by a performance solution.

Please review the highlighted matters with in Annexures A as specifications have been provided

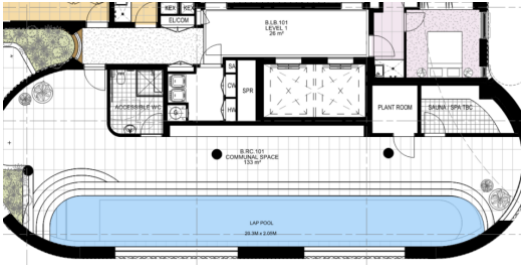
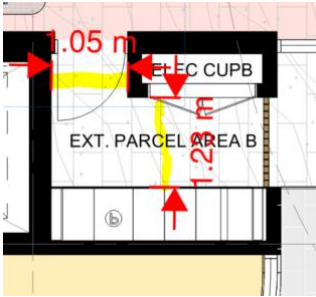
Clauses	Non-Compliance/Information required
D4D2	<p><u>Level 1</u> As lap pool in gym area is more than 40m in perimeter an accessible entry into the pool is required. Communal area is required to be accessible, latch side clearance is required.</p>  <p>Redesign for further assessment.</p> <p><u>Ground floor – parcel area B</u> If parcel area is to be accessed by all occupants, latch and hinge side clearance is required internally. If there is to be another parcel area for occupants please advise.</p>  <p>Does not comply</p>
D4D3	<p>Ensure all doors will have a clear opening of 850mm (920mm doors are recommended to achieve this). The doors also require compliant latch and hinge side clearance with AS 1428.1. Please see D4D2 & D4D3 for specifications.</p> <p>All door to retails and common areas require a clear opening of 850mm and to have circulation in accordance with AS 1428.1.</p> <p>Complies now</p> <p>Ensure all doors will have a clear opening of 850mm (920mm doors are recommended to achieve this). The doors also require compliant latch and hinge side clearance with AS</p>

1428.1. Please see D4D2 & D4D3 for specifications.

Level 01

Circulation space at the doorway doesn't comply (300mm required between basin and door latch)

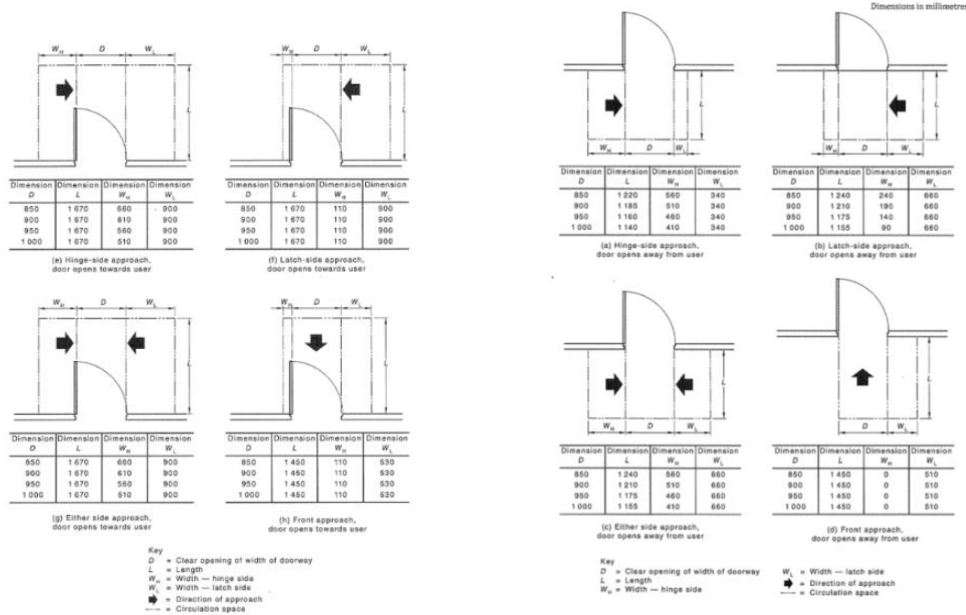
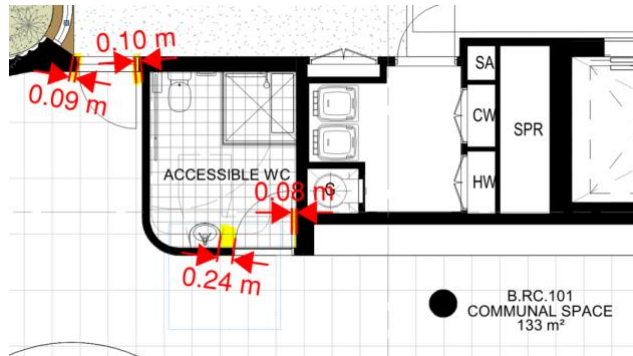

Redesign for further assessment. 'Stil required'

D4D4

All stairs and ramps require double handrails at the top and bottom and in accordance with AS 1428.1.

Ensure this is incorporated

Level 11 – Building A

Ensure stairs comply with AS 1428.1

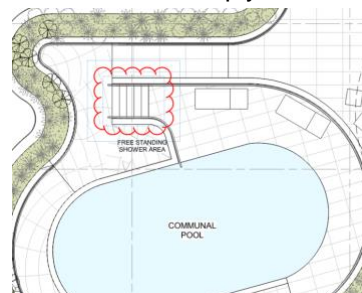

Redesign for further assessment. 'Still required'

Ensure gradients at bottom of stairs and to mid-landings on pedestrian path do not exceed 1:40

Note.

Ground floor – parcel area B

1540mm x 2070mm turning space required at the end of access way, if is an area to be accessed by all occupants

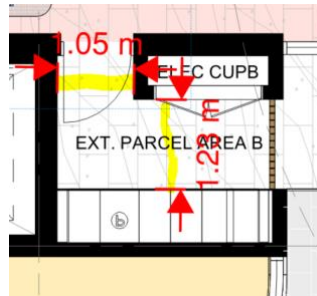

Redesign.

D4D11

Level 1

Communal space to be accessible.

As lap pool in gym area is more than 40m in perimeter an accessible entry into the pool is required.

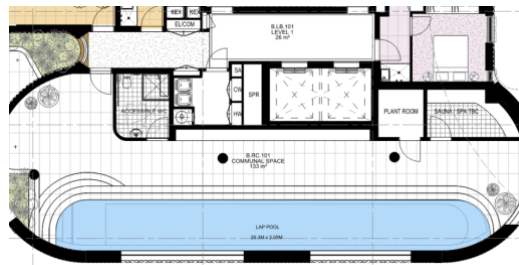

Redesign for further assessment. 'Still required'

F4D5

Level 1 – Accessible WC

Doesn't comply with the requirements of AS1428.1.

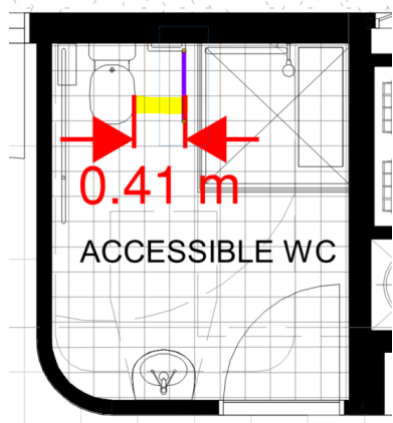
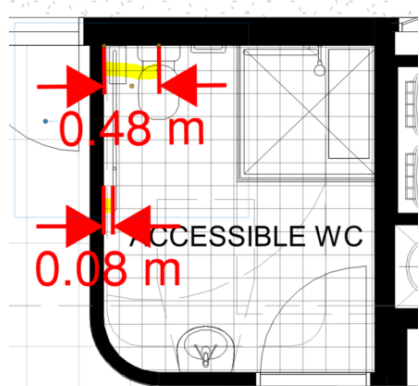

Redesign. 'Still required'

Basement 03 – Accessible WC

Doesn't comply with the requirements of AS1428.1.

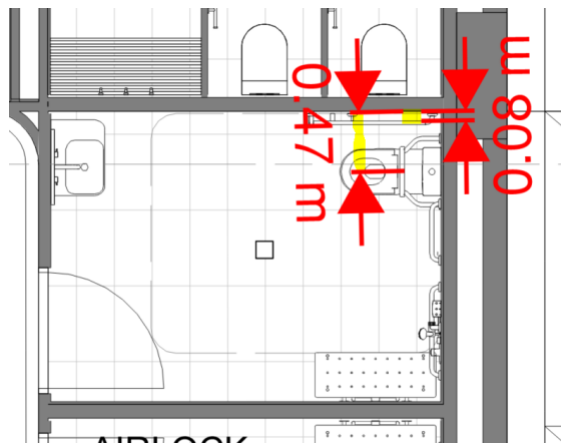

Ambulant toilet to comply with Part 16 of the AS1428.1.

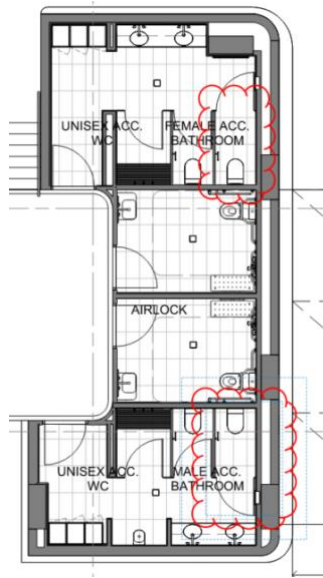

Redesign for further assessment. 'Still required'

Level 11 – Building A

Sanitary facility is required to be accessible and in accordance with AS 1428.1

Note

**Adaptable
Apartments**

20% of apartments are to be adaptable and in accordance with AS 4299.

To be incorporated prior to DA and further assessed prior to CC

Annexure A – Detailed BCA Access Assessment

The table on the following page provides a clause-by-clause assessment of the design against the applicable deemed-to-satisfy provisions of BCA 2022 relating to access for people with disabilities.

The following abbreviations have been used to indicate the compliance status:

NA	Not applicable – The deemed-to-satisfy clause is not applicable to the design
Complies	The design complies with the relevant parts of the deemed-to-satisfy clause
CRA	Compliance readily achievable – The design is consistent with the relevant deemed-to-satisfy clause, however strict compliance with the clause will need to be demonstrated by either certification by the appropriate party or inclusion in the BCA specifications for the project.
DNC	Does Not Comply
FI	Further information is required to confirm compliance
Noted	The clause has been considered in the assessment, however, does not require any further design input.

BCA Access Clause-by-Clause Assessment

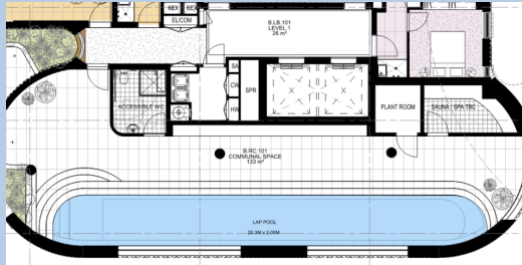
BCA Clause	Relevant Deemed-To-Satisfy Requirements	Comment	Status
Part D4 – Access for people with a disability			
D4D1: Deemed-to Satisfy Provisions	<p>(1) Where a Deemed-to-Satisfy Solution is proposed, Performance Requirements D1P1 to D1P6, D1P8 and D1P9 are satisfied by complying with—</p> <ul style="list-style-type: none"> (a) D2D2 to D2D23, D3D2 to D3D30 and D4D2 to D4D13; and (b) in a building containing an atrium, Part G3; and (c) in a building in an alpine area, Part G4; and (d) for additional requirements for Class 9b buildings, Part I1; and (e) for public transport buildings, Part I2. <p>(2) Where a Performance Solution is proposed, the relevant Performance Requirements must be determined in accordance with A2G2(3) and A2G4(3) as applicable.</p> <p>(3) Performance Requirement D1P7 must be complied with if lifts are to be used to assist occupants to evacuate a building.</p>	-	Noted
D4D2: General building access requirements	<p>(1) Buildings and parts of buildings must be accessible as required by this clause, unless exempted by D4D5.</p> <p>(2) Access requirements for a Class 1b building are as follows:</p> <ul style="list-style-type: none"> (a) Dwellings located on one allotment and used for short-term holiday accommodation — to and within a number of dwellings determined in accordance with Table D4D2a. (b) A boarding house, bed and breakfast, guest house, hostel or the like, other than those described in (a) — to and within— <ul style="list-style-type: none"> (i) 1 bedroom and associated sanitary facilities; and 	<p><u>Level 1</u></p> <p>As lap pool in gym area is more than 40m in perimeter an accessible entry into the pool is required. Communal area is required to be accessible, latch side clearance is required.</p> 	CRA

(ii) not less than 1 of each type of room or space for use in common by the residents or guests, including a cooking facility, sauna, gymnasium, swimming pool, laundry, games room, eating area, or the like; and

(iii) rooms or spaces for use in common by all residents on a floor to which access by way of a ramp complying with AS 1428.1 or a passenger lift is provided.

(3) For the purposes of (2)(a), a community or strata-type subdivision or development is considered to be on a single allotment.

(4) For a Class 2 building, common areas are to be accessible as follows:

(a) From a pedestrian entrance required to be accessible to at least 1 floor containing sole-occupancy units and to the entrance doorway of each sole-occupancy unit located on that level.

(b) To and within not less than 1 of each type of room or space for use in common by the residents, including a cooking facility, sauna, gymnasium, swimming pool, common laundry, games room, individual shop, eating area, or the like.

(c) Where a ramp complying with AS 1428.1 or a passenger lift is installed—

(i) to the entrance doorway of each sole-occupancy unit; and

(ii) to and within rooms or spaces for use in common by the residents.

(c) The requirements of (c) only apply where the space referred to in (c)(i) or (ii) is located on the levels served by the lift or ramp.

Redesign for further assessment. 'Still required'

Access need not be provided to pool area & deck on the rooftop as access is provided to the level 1 pool area. Access need to only be provided to one of each type of area.

Ground floor – parcel area B

If parcel area is to be accessed by all occupants, latch and hinge side clearance is required internally. If there is to be another parcel area for occupants please advise.

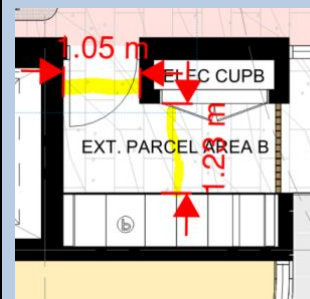

'Still required'

	<p>(6) For Class 5, 6, 7b, 8 and 9a buildings, access must be provided to and within all areas normally used by the occupants.</p> <p>(7) For a Class 7a building, access must be provided to and within any level containing accessible carparking spaces.</p> <p>(10) For a Class 10 building, access requirements are as follows:</p> <ul style="list-style-type: none">(b) For Class 10b swimming pools, to and into swimming pools with a total perimeter greater than 40 m, associated with a Class 1b, 2, 3, 5, 6, 7, 8 or 9 building that is required to be accessible, but not swimming pools for the exclusive use of occupants of a Class 1b building or a sole-occupancy unit in a Class 2 or Class 3 building.		
--	---	--	--

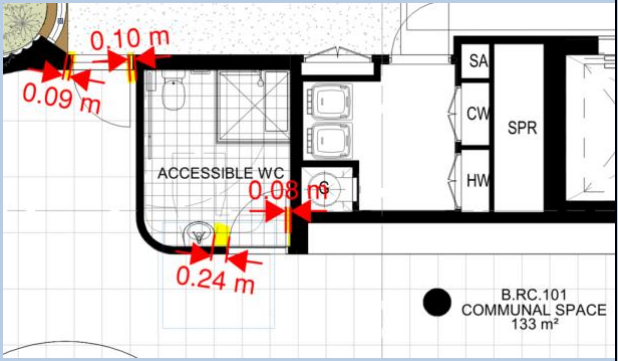
BCA Clause	Relevant Deemed-To-Satisfy Requirements	Comment	Status
D4D3: Access to buildings	<p>(1) An accessway must be provided to a building required to be accessible-</p> <ul style="list-style-type: none"> (a) from the main points of a pedestrian entry at the allotment boundary; and (b) from another accessible building connected by a pedestrian link; and (c) from any required accessible carparking space on the allotment. <p>(2) In a building required to be accessible, an accessway must be provided through the principal pedestrian entrance, and—</p> <ul style="list-style-type: none"> (a) through not less than 50% of all pedestrian entrances including the principal pedestrian entrance; and (b) in a building with a total floor area more than 500 m², a pedestrian entrance which is not accessible must not be located more than 50 m from an accessible pedestrian entrance, <p>Except for pedestrian entrances serving only areas exempted by D4D5.</p> <p>(3) Where a pedestrian entrance required to be accessible has multiple doorways—</p> <ul style="list-style-type: none"> (a) if the pedestrian entrance consists of not more than 3 doorways — not less than 1 of those doorways must be accessible; and (b) if a pedestrian entrance consists of more than 3 doorways — not less than 50% of those doorways must be accessible. <p>(4) For the purposes of (3)—</p> <ul style="list-style-type: none"> (a) an accessible pedestrian entrance with multiple 	<p>Ensure all doors will have a clear opening of 850mm (920mm doors are recommended to achieve this). The doors also require compliant latch and hinge side clearance with AS 1428.1. Please see D4D2 & D4D3 for specifications.</p> <p>All door to retails and common areas require a clear opening of 850mm and to have circulation in accordance with AS 1428.1.</p> <p>Complies now</p> <p>Ensure all doors will have a clear opening of 850mm (920mm doors are recommended to achieve this). The doors also require compliant latch and hinge side clearance with AS 1428.1. Please see D4D2 & D4D3 for specifications.</p> <p><u>Level 01</u> Circulation space at the doorway doesn't comply.</p> 	CRA

doorways is considered to be one pedestrian entrance where—

- (i) all doorways serve the same part or parts of the building; and
- (ii) the distance between each doorway is not more than the width of the widest doorway at that pedestrian entrance (see Figure D4D3); and
- (b) a doorway is considered to be the clear, unobstructed opening created by the opening of one or more door leaves (see Figure D4D3).

(5) Where a doorway on an accessway has multiple leaves (except an automatic opening door), one of those leaves must have a clear opening width of not less than 850 mm in accordance with AS 1428.1.

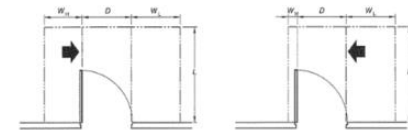
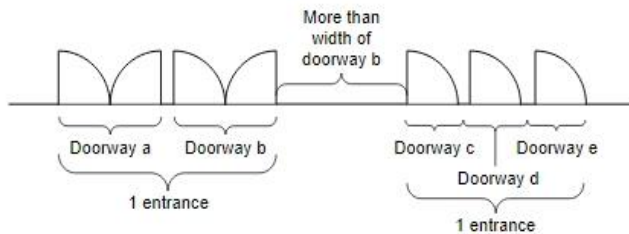

Dimension D	Dimension L	Dimension W _h	Dimension W _l
850	1 670	650	900
900	1 670	610	900
950	1 670	560	900
1 000	1 670	510	900

(e) Hinge-side approach, door opens towards user

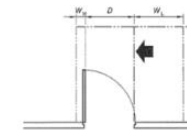

Dimension D	Dimension L	Dimension W _h	Dimension W _l
850	1 670	110	900
900	1 670	110	900
950	1 670	110	900
1 000	1 670	110	900

(f) Latch-side approach, door opens towards user

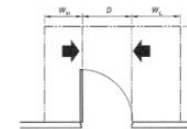

Dimension D	Dimension L	Dimension W _h	Dimension W _l
850	1 670	650	900
900	1 670	610	900
950	1 670	560	900
1 000	1 670	510	900

(g) Either side approach, door opens towards user

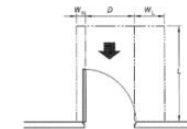

Dimension D	Dimension L	Dimension W _h	Dimension W _l
850	1 450	110	530
900	1 450	110	530
950	1 450	110	530
1 000	1 450	110	530

(h) Front approach, door opens towards user

Key
 D = Clear opening of width of doorway
 L = Length
 W_h = Width — hinge side
 W_l = Width — latch side
 → = Direction of approach
 - - - = Circulation space

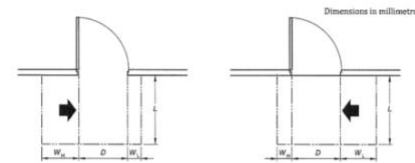

Dimension D	Dimension L	Dimension W _h	Dimension W _l
850	1 220	560	340
900	1 185	510	340
950	1 150	460	340
1 000	1 140	410	340

(a) Hinge-side approach, door opens away from user

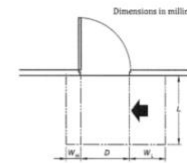

Dimension D	Dimension L	Dimension W _h	Dimension W _l
850	1 240	340	660
900	1 210	190	660
950	1 175	140	660
1 000	1 155	90	660

(b) Latch-side approach, door opens away from user

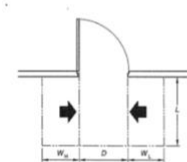

Dimension D	Dimension L	Dimension W _h	Dimension W _l
850	1 240	560	660
900	1 210	510	660
950	1 175	460	660
1 000	1 155	410	660

(c) Either side approach, door opens away from user

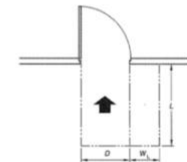

Dimension D	Dimension L	Dimension W _h	Dimension W _l
850	1 450	0	510
900	1 450	0	510
950	1 450	0	510
1 000	1 450	0	510

(d) Front approach, door opens away from user

Key
 D = Clear opening of width of doorway
 L = Length
 W_h = Width — hinge side
 W_l = Width — latch side
 → = Direction of approach
 - - - = Circulation space

Redesign for further assessment. 'Still required'

--	--	--	--

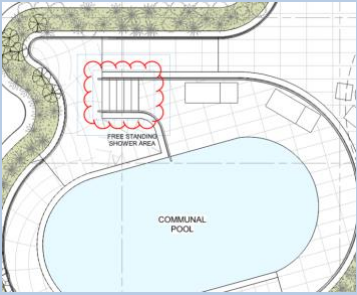
BCA Clause	Relevant Deemed-To-Satisfy Requirements	Comment	Status
D4D4: Parts of buildings to be accessible	<p>In a building required to be accessible—</p> <ul style="list-style-type: none"> (a) every ramp and stairway, except for ramps and stairways in areas exempted by D4D5, must comply with— <ul style="list-style-type: none"> (i) for a ramp, except a fire-isolated ramp, clause 10 of AS 1428.1; and (ii) for a stairway, except a fire-isolated stairway, clause 11 of AS 1428.1; and (iii) for a fire-isolated stairway, clause 11.1(f) and (g) of AS 1428.1; and <p>The fire-isolated stairways must have nosing strips compliant with clause 11.1(f) and (g) of AS 1428.1- 2009.</p> <ul style="list-style-type: none"> (b) every passenger lift must comply with E3D7 and E3D8; and (c) accessways must have— <ul style="list-style-type: none"> (i) passing spaces complying with AS 1428.1 at maximum 20 m intervals on those parts of an accessway where a direct line of sight is not available; and (ii) turning spaces complying with AS 1428.1— <ul style="list-style-type: none"> (A) within 2 m of the end of accessways where it is not possible to continue travelling along the accessway; and (B) at maximum 20 m intervals along the accessway; and (d) an intersection of accessways satisfies the spatial requirements for a passing and turning space; and (e) a passing space may serve as a turning space; and 	<p>All stairs and ramps require double handrails at the top and bottom and in accordance with AS 1428.1.</p> <p>Ensure this is incorporated.</p> <p><u>Level 11 – Building A</u> Ensure stairs comply with AS 1428.1</p>  <p>Redesign for further assessment. 'Still required'</p> <p>Ensure gradients at bottom of stairs and to mid-landings on pedestrian path do not exceed 1:40</p> <p>Note.</p> <p><u>Ground floor – parcel area B</u> 1540mm x 2070mm turning space required at the end of access way, if is an area to be accessed by all occupants</p>	CRA

- (f) a ramp complying with AS 1428.1 or a passenger lift need not be provided to serve a storey or level other than the entrance storey in a Class 5, 6, 7b or 8 building—
- (i) containing not more than 3 storeys; and
- (ii) with a floor area for each storey, excluding the entrance storey, of not more than 200 m²; and
- (g) clause 7.4.1(a) of AS 1428.1 does not apply and is replaced with ‘the pile height or pile thickness shall not exceed 11 mm and the carpet backing thickness shall not exceed 4 mm’; and
- (h) the carpet pile height or pile thickness dimension, carpet backing thickness dimension and their combined dimension shown in Figure 8 of AS 1428.1 do not apply and are replaced with 11 mm, 4 mm and 15 mm respectively.

Passing spaces (1800 x 2000 mm) complying with AS1428.1 at 20 m max. intervals where direct line of sight is not available.

Turning spaces (1540 x 2070 mm) complying with AS1428.1 within 2 m of the end of accessways (including corridors or the like); and at 20 m max. intervals along an accessway.

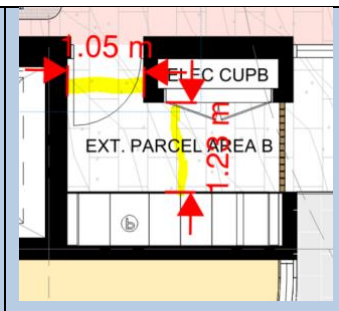

Redesign. ‘Still required’

Australian Standard Clauses

Relevant Australian Standard Clauses to D4D4

Clause 10 – Walkways, Ramps and Landings

Walkways, ramps and landings that are provided on a continuous accessible path of travel shall be as follows:

10.1 General

- (a) Sharp transitions shall be provided between the planes of landings and ramps, as shown in Figure 13.
- (b) Landings shall be provided at all changes in direction in accordance with Clause 10.8.
- (c) Landing or circulation space shall be provided at every doorway, gate, or similar opening.
- (d) For walkways and landings having gradients in the direction of travel shallower than 1 in 33, a camber or crossfall shall be provided for shedding of water and shall be no steeper than 1 in 40, except that bitumen surfaces shall have a camber or crossfall no steeper than 1 in 33.

NOTE: A summary of requirements for walkways, ramps and landings is provided in Appendix C.

10.2 Walkways

Walkways shall comply with the following:

- (a) The floor or ground surface abutting the sides of the walkway shall provide a firm and level surface of a different material to that of the walkway at the same level of the walkway, follow the grade of the walkway and extend horizontally for a minimum of 600 mm unless one of the following is provided:
 - (i) Kerb in accordance with Figure 18.
 - (ii) Kerb rail and handrail in accordance with Figure 19.
 - (iii) A wall not less than 450 mm in height.
- (b) Walkways shall be provided with landings, as specified in Clause 10.8, at intervals not

	<p>exceeding the following:</p> <ul style="list-style-type: none"> (i) For walkway gradients of 1 in 33, at intervals no greater than 25 m. (ii) For walkway gradients of 1 in 20, at intervals no greater than 15 m. (iii) For walkway gradients between 1 in 20 to 1 in 33, at intervals that shall be obtained by linear interpolation. <p>For walkways shallower than 1 in 33, no landings are required. The intervals specified above may be increased by 30% where at least one side of a walkway is bounded by-</p> <ul style="list-style-type: none"> (A) a kerb or kerb rail as specified in Clause 10.3(j) and a handrail as specified in Clause 12; or (B) a wall and a handrail as specified in Clause 12. <p>10.3 Ramps Ramps shall comply with the following:</p> <ul style="list-style-type: none"> (a) The maximum gradient of a ramp exceeding 1900 mm in length shall be 1 in 14. (b) The gradient of a ramp shall be constant throughout its length with a maximum allowable tolerance of 3% provided no section of the ramp is steeper than 1 in 14. (c) Ramps shall be provided with landings, as specified in Clause 10.8, at the bottom and at the top of the ramp and at intervals not exceeding the following: <ul style="list-style-type: none"> (i) For ramp gradients of 1 in 14, at intervals not greater than 9 m. (ii) For ramp gradients steeper than 1 in 20, at intervals not greater than 15 m. 		
--	---	--	--

- (iii) For ramp gradients between 1 in 14 and steeper than 1 in 20, at intervals that shall be obtained by linear interpolation.
- (d) Where ramps are constructed with a change in direction, the angle of approach shall create a 90° angle to the line of transition between the ramp surface and the landing surface, as shown in Figure 13.
- (e) Ramps shall have a handrail complying with Clause 12 on each side of the ramp, as shown in Figure 14.

NOTE: Figures 15(A) and 15(B) show examples of suitable ramp handrail terminations.

- (f) Where the intersection is at the property boundary, the ramp shall be set back by a minimum of 900 mm so that the handrail (complying with Clause 12) and TGSIs do not protrude into the transverse path, as shown in Figure 16.

TGSIs shall be installed in accordance with AS 1428.4.1.

- (g) Where the intersection is at an internal corridor, the ramp shall be set back by a minimum of 400 mm so that the handrail complying with Clause 12 does not protrude into the transverse path of travel as shown in Figure 17.
- (h) The handrail shall extend a minimum of 300 mm horizontally past the transition point at the top and bottom of the ramp except where the inner handrail is continuous at an intermediate landing.
- (i) Ramps and intermediate landings shall have kerbs or kerb rails on both sides that comply with the following:

	<ul style="list-style-type: none"> (ii) The minimum height above the finished floor shall be 65 mm. (iii) The height of the top of the kerb or kerb rail shall not be within the range 75 mm to 150 mm above the finished floor, as shown in Figure 18. (iv) There shall be no longitudinal gap or slot greater than 20 mm in the kerb or kerb rail within the range 75 mm to 150 mm above the finished floor. <p>NOTES: 1- For kerb rails see Figure 18. 2- For location of kerb or kerb rail, see Figure 19. 3- Examples of kerb rail configuration are shown in Appendix A</p> <ul style="list-style-type: none"> (j) Kerbs or kerb rails shall— <ul style="list-style-type: none"> (i) be located so that the ramp-side face is either flush with the ramp-side face of the handrail or no greater than 100 mm away from the ramp-side face of the handrail, as shown in Figure 19; (ii) where the handrail is supported on a vertical post, the height of the top of the kerb or kerb rail shall be not less than 150 mm above the finished floor, as shown in Figures 19(a), 19(b) or 19(c); and (iii) where the kerb is at a height of 65 mm to 75 mm, the support posts shall be set back a minimum of 200 mm from the face of the kerb or kerb rail, as shown in Figure 19(d). 		
--	--	--	--

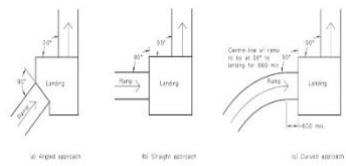

DIMENSIONS IN MILLIMETRES

FIGURE 13 ANGLE OF APPROACH BETWEEN RAMP AND LANDING

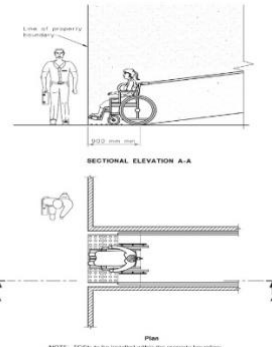
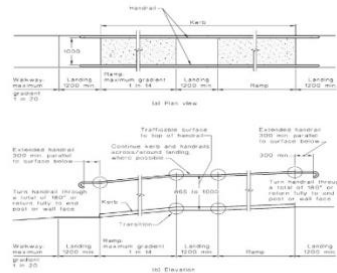
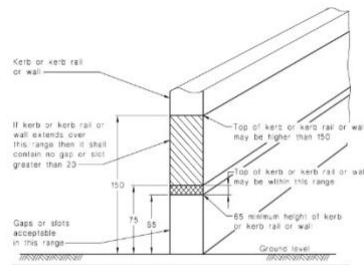

FIGURE 16 LOCATION OF RAMP AT A BOUNDARY TO PREVENT PROTRUSION OF HANDRAILS AND TACTILE GROUND SURFACE INDICATORS (TGSIs) INTO A TRANSVERSE PATH OF TRAVEL



DIMENSIONS IN MILLIMETRES

FIGURE 14 RAMP HANDRAILS



DIMENSIONS IN MILLIMETRES

FIGURE 18 KERB RAIL

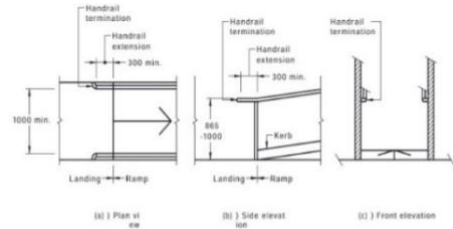

DIMENSIONS IN MILLIMETRES

FIGURE 15(B) RAMP HANDRAILS—DETAIL FOR HANDRAILS TERMINATED BY TURNING HORIZONTALLY THROUGH 90° TO THE WALL

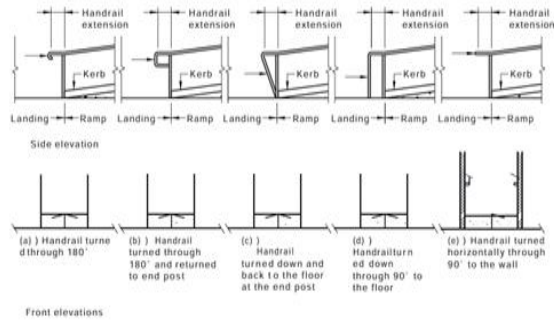

FIGURE 15(A) RAMP HANDRAILS—EXAMPLES OF HANDRAIL TERMINATIONS

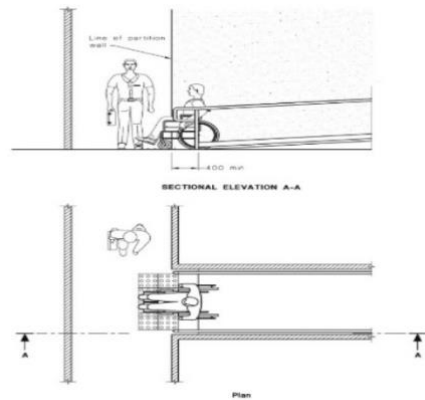

FIGURE 17 LOCATION OF RAMP TO PREVENT PROTRUSION OF HANDRAILS INTO A TRANSVERSE PATH OF TRAVEL OTHER THAN AT BOUNDARIES

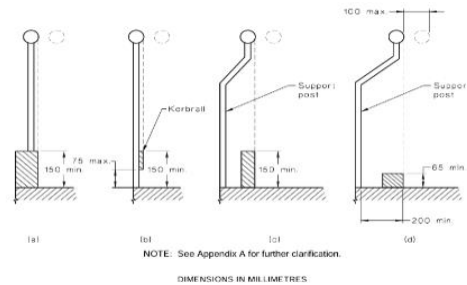

FIGURE 19 SECTION SHOWING LOCATION OF KERB OR KERB RAIL IN RELATION TO HANDRAIL WITH VERTICAL SUPPORT

10.4 Curved walkways, ramps, and landings

Curved ramps, walkways and landings shall comply with the following:

- The gradient of curved ramps and walkways shall comply with Figure 20.
- Landings shall comply with Clause 10.8.
- The length of a curved ramp shall be measured horizontally along its centre-line.
- Curved ramps and walkways shall have a width of not less than 1500 mm.
- Any crossfall shall be towards the centre of curvature.

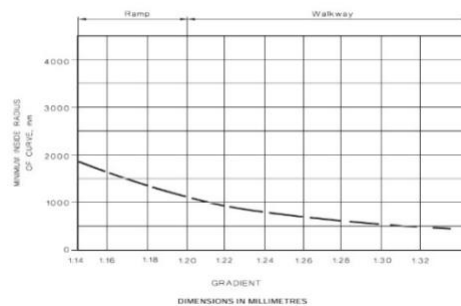

FIGURE 20 CURVED RAMP AND WALKWAY GRADIENTS

10.5 Threshold ramps

Threshold ramps at doorways on a continuous path of travel shall have—

- (a) a maximum rise of 35 mm;
- (b) a maximum length of 280 mm;
- (c) a maximum gradient of 1:8; and
- (d) be located within 20 mm of the door leaf which it serves, as shown in Figure 21.

The edges of the threshold ramp shall be tapered or splayed at a minimum of 45° where the ramp does not abut a wall.

NOTE: For door controls, see Clause 13.5

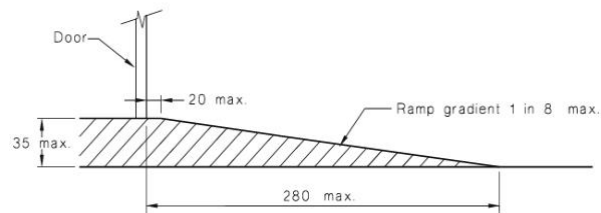

DIMENSIONS IN MILLIMETRES

FIGURE 21 THRESHOLD RAMP

10.6 Step ramps

10.6.1 General

Step ramps shall have—

- (a) a maximum rise of 190 mm;
- (b) a length not greater than 1900 mm; and
- (c) a gradient not steeper than 1 in 10.

Step ramps shall be as shown in Figures 22(A) and 22(B), as appropriate.

The edges of step ramp shall have a 45° splay where there is pedestrian cross traffic. Otherwise, it shall be protected by a suitable barrier, as shown in Figure 22(B), such as—

- (i) a wall or suitable barrier with a minimum height of 450 mm; or
- (ii) where an open balustrade is provided a kerb or kerb rail shall be provided.

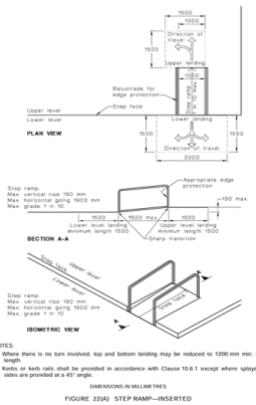

NOTES:
 1 Where there is no fare involved, top and bottom landing may be reduced to 1200 mm min. in length.
 2 Kerbs or kerb rails shall be provided in accordance with Clause 10.6.1 except where splayed sides are provided at a 45° angle.

DIMENSIONS IN MILLIMETRES

FIGURE 22(A) STEP RAMP—INSERTED

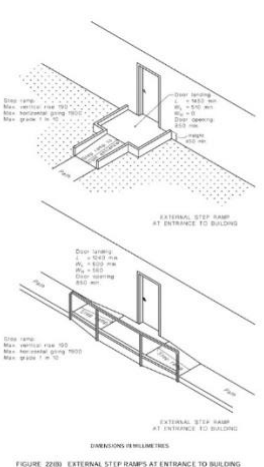

DIMENSIONS IN MILLIMETRES

FIGURE 22(B) EXTERNAL STEP RAMP AT ENTRANCE TO BUILDING

10.6.2 Finishes

Step ramps shall have a slip-resistant surface.

10.7 Kerb ramps

10.7.1 Alignment

Kerb ramps shall be aligned in the direction of travel, as shown in Figure 23.

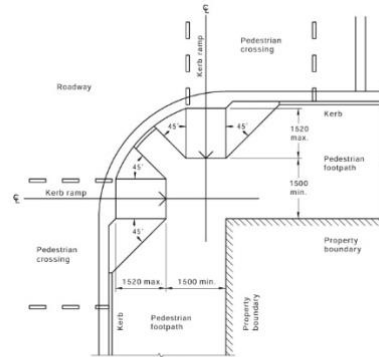

- NOTES:
- 1 Centre-line of kerb ramps and pedestrian refuges shall align across the road.
 - 2 Top and bottom of kerb ramps shall be aligned at 90° to path of travel.
 - 3 Top and bottom of kerb ramps shall have a sharp gradient transition.
 - 4 For requirements for tactile ground surface indicators see AS 1428.4.1.

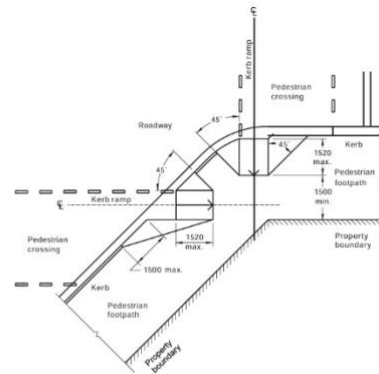

- NOTES:
- 1 Centre-line of kerb ramps and pedestrian refuges shall align across the road.
 - 2 Top and bottom of kerb ramps shall have a sharp gradient transition.
 - 3 For requirements for tactile ground surface indicators see AS 1428.4.1.
 - 4 For requirements for pedestrian lights and push-button assemblies see AS 1742.14.

(b) 45° road intersection

DIMENSIONS IN MILLIMETRES

FIGURE 23 (in part) ALIGNMENT OF KERB RAMPS

10.7.2 Profile

Kerb ramps shall have—

- (a) a maximum rise of 190 mm;
- (b) a length not greater than 1520 mm; and
- (c) a gradient not steeper than 1 in 8, located within or attached to a kerb.

The profile of ramps shall comply with the following:

- (i) The design and construction of kerb ramps shall be as shown in Figures 24(A), 24(B) and 24(C).
- (ii) The sloping sides of a kerb ramp shall be tapered or splayed as indicated in Figures 24(A) and (24(B).
- (iii) The angle at the base of the kerb ramp shall be a minimum of 166° as shown in Figures 24(A) and 24(B).

10.7.3 Finishes

Kerb ramps shall have a slip-resistant surface.

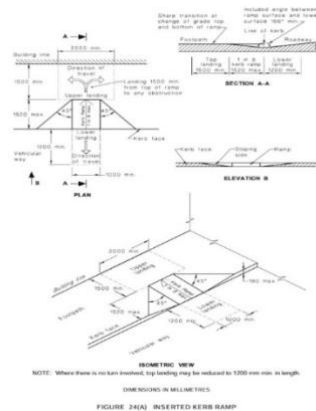

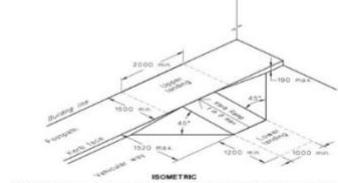
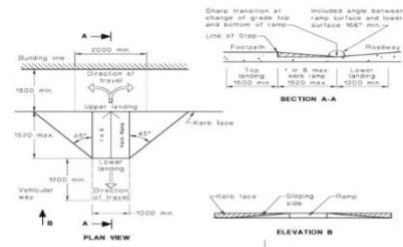

NOTE: Where there is no turn involved, top landing may be reduced to 1200 mm min. in length.

DIMENSIONS IN MILLIMETRES

FIGURE 24(B) ATTACHED KERB RAMP

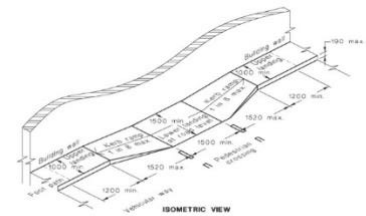
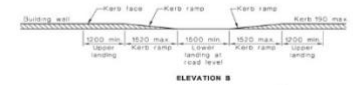
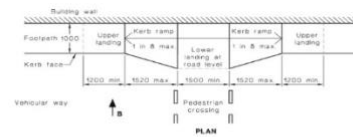

DIMENSIONS IN MILLIMETRES

FIGURE 24(C) IN LINE KERB RAMP'S—NARROW FOOTPATHS

10.8 Landings

10.8.1 Walkways and ramps

The length of landings at walkways (up to a gradient of 1 in 33) and ramps shall comply with one of the following:

- (a) Where there is no change in direction, the length shall be not less than 1200 mm, as shown in Figure 25(A).
- (b) Where there is a change of direction not exceeding 90°, the landing shall be not less than 1500 mm. The internal corner shall be truncated for a minimum of 500 mm in both directions, as shown in Figure 25(B).
- (c) For a 180° turn, the landing shall be as shown in Figure 25(C),

10.8.2 Step ramps

The length of landings at step ramps shall be not less than 1200 mm in the direction of travel, as shown in Figures 22(A) and 22(B).

Where a change in direction is required, the length of step ramp landings shall be a minimum of 1500 mm, as shown in Figure 22(A).

Where doorways are at landings, the dimensions of the landings shall be in accordance with the requirements of Clause 13.3 for circulation spaces at doorways shown in Figure 25(D).

10.8.3 Kerb ramps

The length of landings at kerb ramps shall be not less than 1200 mm in the direction of travel.

Where a 'T' junction occurs, the kerb ramp landing shall be a minimum of 1500 x 2000 mm, as shown in Figure 24(B).

Where a single change in direction is required, the ramp landings shall be a minimum of 1500 mm x 1500 mm.

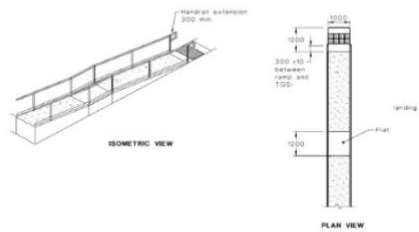

DIMENSIONS IN MILLIMETRES
 FIGURE 25(A) RAMP AND LANDINGS—WITH NO CHANGE IN DIRECTION

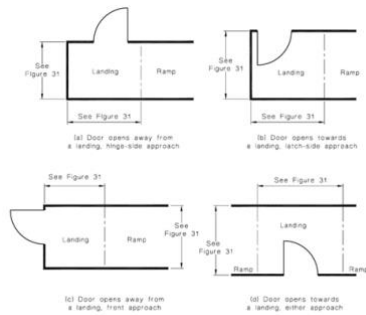
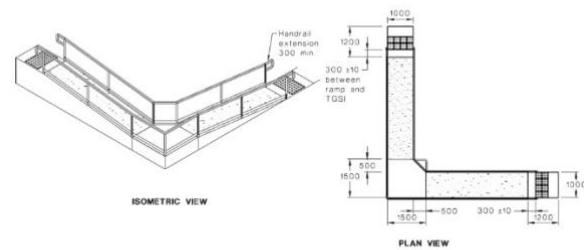
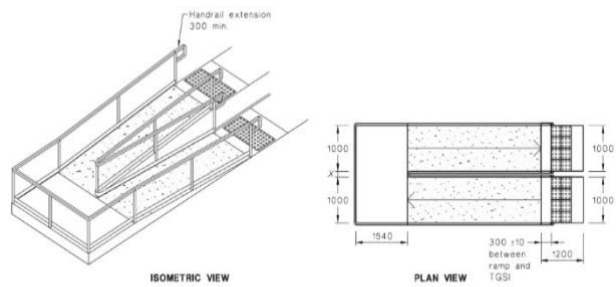

FIGURE 25(D) DOORWAYS AT LANDINGS



DIMENSIONS IN MILLIMETRES
 FIGURE 25(B) RAMP AND LANDINGS—90° LANDING—INTERNAL



DIMENSIONS IN MILLIMETRES
FIGURE 25(C) RAMPS AND LANDINGS—180° LANDING

Clause 11 - Stairs

11 Stairways

11.1 Stair construction

Where required, stairs shall be constructed as follows:

- (a) Where the intersection is at the property boundary, the stair shall be set back by a minimum of 900 mm so that the handrail (complying with Clause 12) and TGSIs do not protrude into the transverse path of travel, as shown in Figure 26(A).
- (b) Where the intersection is at an internal corridor, the stair shall be set back in accordance with Figure 26(B).

NOTE: Examples of stair handrail terminations are given in Figures 26(C) and 26(D).

- (c) Stairs shall have opaque risers.
- (d) Stair nosings shall not project beyond the face of the riser and the riser may be vertical or have a splay backwards up to a maximum 25 mm, as shown in
- (e) Figures 27(A) and 27(B).
- (f) Stair nosing profiles shall—
 - (i) have a sharp intersection;
 - (ii) be rounded up to 5 mm radius; or
 - (iii) be chamfered up to 5 mm × 5 mm.
- (f) At the nosing, each tread shall have a strip not less than 50 mm and not more than 75 mm deep across the full width of the path of travel. The strip may be set back a maximum of 15 mm from the front of the nosing. The strip shall have a

minimum luminance contrast of 30% to the background. Where the luminous contrasting strip is affixed to the surface of the tread, any change in level shall comply with Clause 7.2 and Clause 7.3.

- (g) Where the luminance contrasting strip is not set back from the front of the nosing then any area of luminance contrast shall not extend down the riser more than 10 mm.
- (h) TGSIs shall be installed in accordance with AS 1428.4.1.

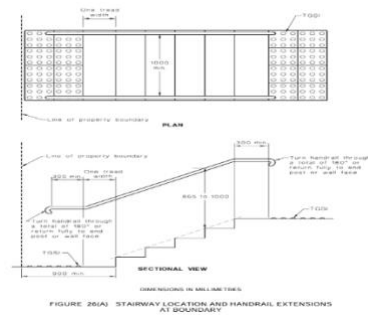

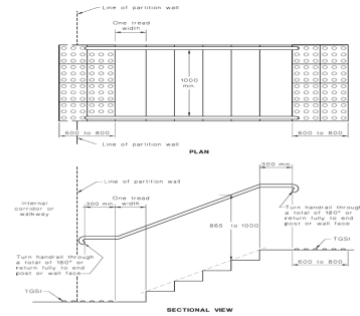

FIGURE 26(B) STAIRWAY LOCATION AND HANDRAIL EXTENSIONS AT END OF STAIRWAY OTHER THAN AT LINE OF BOUNDARY

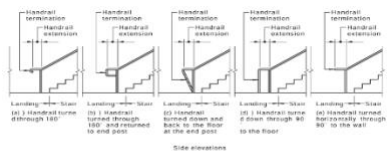

FIGURE 26(C) STAIR HANDRAILS—HANDRAIL TERMINATIONS

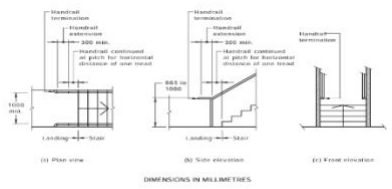

FIGURE 26(D) DETAIL FOR HANDRAILS TERMINATED BY TURNING HORIZONTALLY THROUGH 90° TO THE WALL

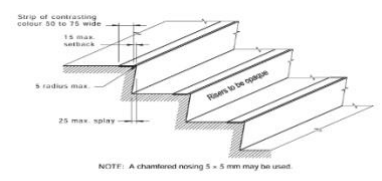

FIGURE 27(A) A TYPICAL STAIR NOSING PROFILE WITH NOSING STRIP

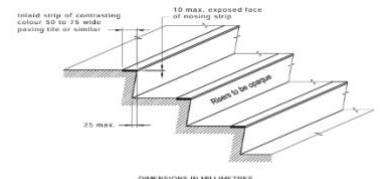
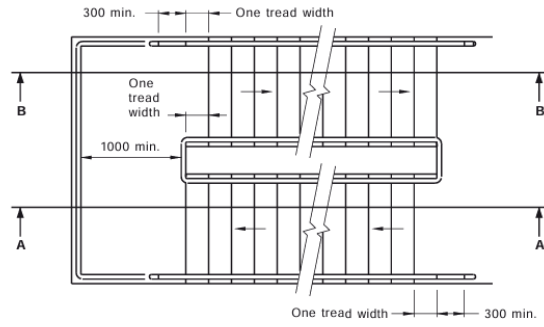

FIGURE 27(B) A TYPICAL STAIR NOSING PROFILE WITH EXPOSED NOSING STRIP

11.2 Stairway handrails

Handrails shall be continuous throughout the stair flight and, where practicable, around landings (see Figure 28) and have no obstruction on or above up to a height of 600 mm and as follows:

- (a) The design and construction of handrails shall comply with Clause 12.
- (b) Handrails shall be installed on both sides of the stairs and as shown in Figures 26(A) and 26(B).
- (c) Handrails shall have no vertical sections and shall follow the angle of the stairway nosings, as shown in Figure 28(b).
- (d) Where a handrail terminates at the bottom of a flight of stairs, the handrail shall extend at least one tread depth parallel to the line of nosings plus minimum of 300 mm horizontally from the last riser (see Figure 28(b)).
- (e) The handrail shall extend a minimum of 300 mm horizontally past the nosing on the top riser.
- (f) Where the handrail is continuous, the 300 mm extension is not required in the inner handrail at intermediate landings as shown in Figure 28(a).
- (g) The dimensions indicating the heights of handrails shall be taken vertically from the nosing of the tread to the top of the handrail or from the landing to the top of the handrail.



(a) Plan

DIMENSIONS IN MILLIMETRES

FIGURE 28 (in part) HANDRAILS TO STAIRS WITH INTERMEDIATE LANDINGS

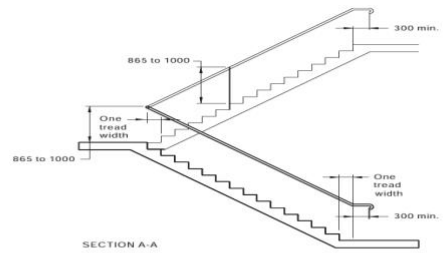

SECTION A-A

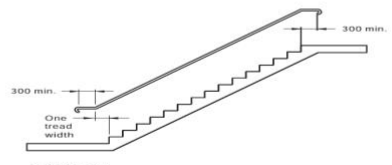

SECTION B-B

(b) Sections

DIMENSIONS IN MILLIMETRES

FIGURE 28 (in part) HANDRAILS TO STAIRS WITH INTERMEDIATE LANDINGS

<p>Clause 12 Handrails</p>	<p>12 Handrails</p> <p>The design and construction of handrails shall comply with the following:</p> <ul style="list-style-type: none"> (a) Handrails and balustrades shall not encroach into required circulation spaces. (b) The cross-section of handrails shall be circular or elliptical, not less than 30 mm or greater than 50 mm in height or width for not less than 270° around the uppermost surface as shown in Figures 29(a) and 29(b). Elliptical handrails shall have the greater dimension in the horizontal axis as shown in Figure 29(b). (c) Exposed edges at ends and corners of handrails shall have a radius of not less than 5 mm. (d) The top of handrails shall be not less than 865 mm nor more than 1000 mm above the nosing of stairway tread or the plane of the finished floor of the walkway, ramp or landing. (e) The height of the top of the handrail, measured in accordance with Item (d), shall be consistent through the ramp (or stairs) and any landings. (f) If a balustrade is required at a height greater than the handrail, both shall be provided. (g) Handrails shall be securely fixed and rigid, and their ends shall be turned through a total of 180°, or to the ground, or returned fully to end post or wall face, as shown in Figures 26(C) and 26(D). (h) The clearance between a handrail and an adjacent wall surface or other obstruction shall be not less than 50 mm. This clearance shall extend above the top of the handrail by not less than 600 mm. 		
----------------------------	--	--	--

- (i) Handrails shall have no obstruction to the passage of a hand along the rail, as shown in Figures 29(a) and 29(b).
- (j) The inside handrail at landings shall always be continuous, as shown in Figure 28(a).

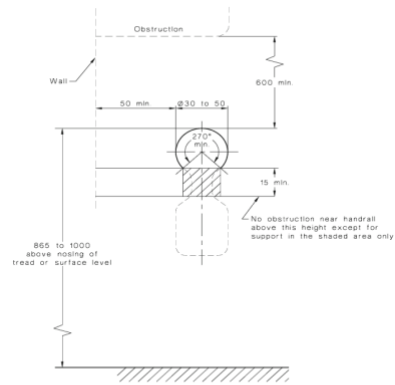

(a) Circular

DIMENSIONS IN MILLIMETRES
FIGURE 29 (in part) HANDRAILS

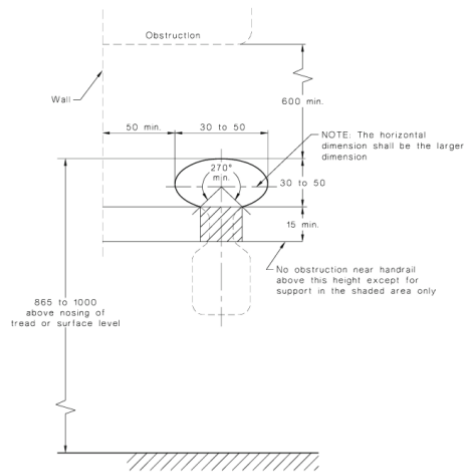

(b) Elliptical

DIMENSIONS IN MILLIMETRES
FIGURE 29 (in part) HANDRAILS

D4D5: Exemptions	<p>The following areas are not required to be <i>accessible</i>:</p> <ul style="list-style-type: none"> (a) An area where access would be inappropriate because of the particular purpose for which the area is used. (b) An area that would pose a health or safety risk for people with a disability. (c) Any path of travel providing access only to an area exempted by (a) or (b). 	<p>The following areas within this development have been identified as exempted areas:</p> <ul style="list-style-type: none"> - Comms rooms - Maintenance rooms/ Plant room - Service rooms - Stores 	Note
D4D6: Accessible carparking	<p>In accordance with Clause D4D6 of the BCA, one accessible car space compliant with AS/NZS 2890.6-2009 is required for the commercial use.</p> <p>For each class of building to which the <i>carpark</i> or carparking area is associated, the number of <i>accessible</i> carparking spaces <i>required</i> is as follows:</p> <ul style="list-style-type: none"> a. Class 1b and 3 buildings: <ul style="list-style-type: none"> i. For a boarding house, guest house, hostel, lodging house, backpackers' accommodation or the residential part of a hotel or motel, the number of <i>accessible</i> carparking spaces <i>required</i> is to be calculated by multiplying the total number of carparking spaces by the percentage of — <ul style="list-style-type: none"> 1. <i>accessiblesole-occupancy units</i> to the total number of <i>sole-occupancy units</i>; or 2. <i>accessible</i> bedrooms to the total number of bedrooms. ii. For the purposes of (i), the calculated number is taken to the next whole figure. iii. For a residential part of a <i>school</i>, accommodation for the aged, disabled or children, residential part of a <i>health-care building</i> which accommodates members of staff or the residential part of a <i>detention centre</i> — <ul style="list-style-type: none"> 1 <i>accessible</i> space for every 100 carparking spaces or part thereof. 	<p>Required for class 6 (retail).</p> <p>2 accessible carpark spaces provided for retail (located between retail parking spaces).</p> <p>24 accessible carpark spaces provided for class 2.</p> <p>The size and layout requirements comply.</p> <p>To be in accordance with AS2890.6.</p>	CRA

- b. Class 5, 7, 8 or 9c buildings —
1 *accessible* space for every 100 carparking spaces or part thereof.
- c. Class 6 buildings—
 - i. with up to 1000 carparking spaces —
1 *accessible* space for every 50 carparking spaces or part thereof; and
 - ii. for each additional 100 carparking spaces or part thereof in excess of 1000 carparking spaces —
1 *accessiblespace*.
- d. Class 9a buildings:
 - i. For a hospital (non-outpatient area) —
1 *accessible* space for every 100 carparking spaces or part thereof.
 - ii. For a hospital (outpatient area)—
 - 1. with up to 1000 carparking spaces — 1 *accessible* space for every 50 carparking spaces or part thereof; and
 - 2. for each additional 100 carparking spaces or part thereof in excess of 1000 carparking spaces —
1 *accessiblespace*.
 - iii. For a nursing home —
1 *accessible* space for every 100 carparking spaces or part thereof.
 - iv. For a clinic or day surgery not forming part of a hospital — 1 *accessible* space for every 50 carparking spaces or part thereof.
- e. Class 9b buildings:
 - i. For a *school* — 1 *accessible* space for every 100 carparking spaces or part thereof.
 - ii. For other *assembly buildings*—
 - 1. with up to 1000 carparking spaces — 1 *accessible* space for every 50 carparking spaces or part thereof; and
 - 2. for each additional 100 carparking spaces or part thereof in excess of 1000

	<p style="text-align: center;">carparking spaces — 1 <i>accessible</i> space.</p> <p>2.2 Parking Spaces—Dimensions 2.2.1 Angle parking spaces</p> <p>(a) A dedicated (non-shared) space as follows: In Australia—2400 mm wide by 5400 mm long.</p> <p>(b) A shared area on one side of the dedicated space as follows: In Australia—2400 mm wide by 5400 mm long. It may be entirely on the left or entirely on the right side of the dedicated space.</p> <p>(c) A shared area 2400 mm long by 2400 mm wide at one end of the dedicated space. It may be entirely at the front or entirely at the rear of the dedicated space.</p> <p>(d) The dedicated space and the shared area shall be at the same level.</p> <p>(e) In Australia only—bollards shall be provided in the positions shown in Figures 2.2 and 2.3.</p> <p>(f) The angle-parking angle shall be between 45 degrees and 90 degrees. It is not required that all spaces within a car park be at the same parking angle.</p> <p>NOTE: Examples of angle parking spaces are shown in Figures 2.2 and 2.3.</p>		
--	---	--	--

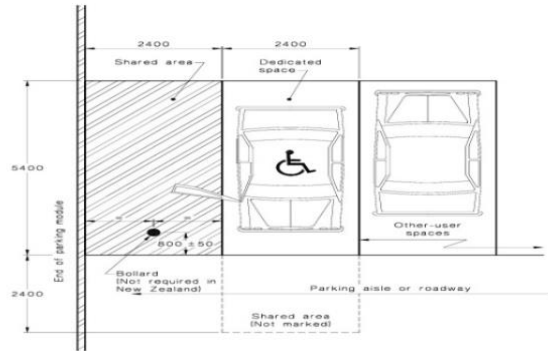

DIMENSIONS IN MILLIMETRES
 FIGURE 2.2 EXAMPLE OF AN ANGLE PARKING SPACE WITH SHARED AREA ON ONE SIDE ONLY—DIMENSIONS FOR AUSTRALIA ONLY*

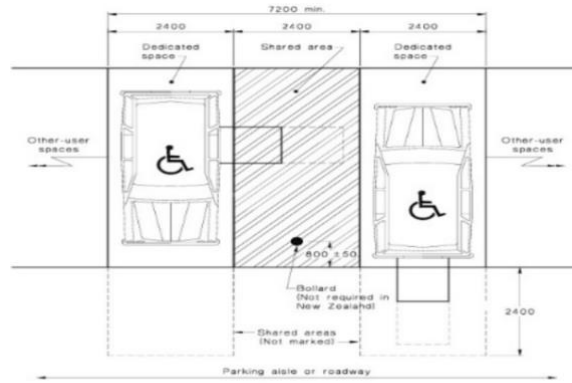

DIMENSIONS IN MILLIMETRES
 FIGURE 2.3 EXAMPLE OF TWO PARKING SPACES WITH A COMMON SHARED AREA—DIMENSIONS FOR AUSTRALIA ONLY*

2.4 Headroom

The path of vehicular travel from the car park entrance to all parking spaces for people with disabilities and from those spaces to the car park exit shall have a minimum headroom of 2200 mm.

The headroom above each dedicated space and adjacent shared area, measured from the level of the dedicated space shall be a minimum of 2500 mm.

For an angle parking space the headroom of the front of the space and its adjacent shared area may be reduced to lie within the profile shown in Figure 2.7.

NOTES:

Where a wheelchair hoist is used, although the wheelchair is stored on the vehicle roof in a flat position, it is raised to full wheelchair height (in addition to the height of the roof rack) during the hoisting process.

The method of measuring headroom is given in AS/NZS 2890.1.

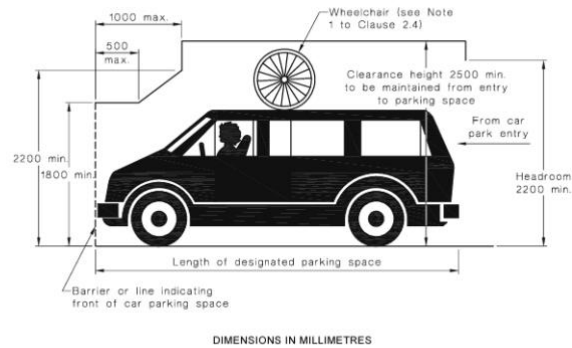

FIGURE 2.7 HEADROOM REQUIRED ABOVE CAR SPACES FOR PEOPLE WITH DISABILITIES

BCA Clause	Relevant Deemed-To-Satisfy Requirements	Comment	Status
D4D7: Signage	<p>(1) In a building required to be accessible—</p> <ul style="list-style-type: none"> (a) braille and tactile signage complying with Specification 15 must — <ul style="list-style-type: none"> (i) incorporate the international symbol of access, in accordance with AS 1428.1 and identify each— <ul style="list-style-type: none"> (A) sanitary facility, except a sanitary facility associated with a bedroom in a Class 1b building or a sole-occupancy unit in a Class 3 or Class 9c building; and (B) (not applicable) (ii) identify each door required by E4D5 to be provided with an exit sign and state— <ul style="list-style-type: none"> (A) “Exit”; and (B) “Level”; and (C) the floor level number or floor level descriptor, or a combination of the two. (b) signage including the international symbol for deafness in accordance with AS 1428.1 must be provided within a room containing a hearing augmentation system identifying— <ul style="list-style-type: none"> (i) the type of hearing augmentation; and (iii) the area covered within the room; and (iv) if receivers are being used and where the receivers can be obtained; and (c) signage in accordance with AS 1428.1 must be provided for <i>accessible</i> unisex sanitary facilities to identify if the facility is suitable for left or right handed use. 	To be assessed prior to CC.	CRA

	<ul style="list-style-type: none"> (d) signage to identify an ambulant accessible sanitary facility in accordance with AS 1428.1 must be located on the door of the facility; and (e) where a pedestrian entrance is not accessible, directional signage incorporating the international symbol of access, in accordance with AS 1428.1, must be provided to direct a person to the location of the nearest accessible pedestrian entrance; and (f) where a pedestrian entrance is not accessible, directional signage incorporating the international symbol of access, in accordance with AS 1428.1, must be provided to direct a person to the location of the nearest accessible pedestrian entrance; and <p>(2) In a building that is subject to F4D12 and is required to be accessible, directional signage complying with Specification 15 to direct a person to the location of the nearest accessible adult change facility within that building must be provided at the location of each—</p> <ul style="list-style-type: none"> (a) bank of sanitary facilities; and (a) accessible unisex sanitary facility, other than one that incorporates an accessible adult change facility. 		
--	---	--	--

BCA Clause	Relevant Deemed-To-Satisfy Requirements	Comment	Status
D4D8: Hearing augmentation	<p>A hearing augmentation system must be provided where an inbuilt amplification system, other than one used only for emergency warning, is installed—</p> <ul style="list-style-type: none"> (a) in a room in a Class 9b building; or (b) in an auditorium, conference room, meeting room or room for judicatory purposes; or (c) at any ticket office, teller's booth, reception area or the like, where the public is screened from the service provider. 	-	NA
D4D9: Tactile indicators	<ul style="list-style-type: none"> (1) For a building required to be accessible, tactile ground surface indicators must be provided to warn people who are blind or have a vision impairment that they are approaching— <ul style="list-style-type: none"> (a) a stairway, other than a fire-isolated stairway; and (b) an escalator; and (c) a passenger conveyor or moving walk; and (d) a ramp other than a fire-isolated ramp, step ramp, kerb ramp or swimming pool ramp; and (e) in the absence of a suitable barrier— <ul style="list-style-type: none"> (i) an overhead obstruction less than 2 m above floor level, other than a doorway; and (ii) an accessway meeting a vehicular way adjacent to any pedestrian entrance to a building, excluding a pedestrian entrance serving an area referred to in D4D5, if there is no kerb or kerb ramp at that point, <p>Except for areas exempted by D4D5.</p> (2) Tactile ground surface indicators required by (1) must comply with sections 1 and 2 of AS/NZS 1428.4.1. (3) A hostel for the aged, nursing home for the aged, a residential aged care building, Class 3 accommodation for the aged, Class 9a health-care building or a Class 9c aged care building need not 	To be assessed prior to CC.	CRA

	comply with (1)(a) and (d) if handrails incorporating a raised dome button in accordance with AS/NZS 1428.4.1 are provided to warn people who are blind or have a vision impairment that they are approaching a stairway or ramp.																																										
D4D10: Wheelchair seating spaces in Class 9b assembly buildings	<p>Where fixed seating is provided in a Class 9b assembly building, wheelchair seating spaces complying with AS 1428.1 must be provided in accordance with the following:</p> <p>(a) The number and grouping of wheelchair seating spaces must be in accordance with Table D4D10.</p> <p>(b) In a cinema—</p> <p>(i) with not more than 300 seats — wheelchair seating spaces must not be located in the front row of seats; and</p> <p>(ii) with more than 300 seats — not less than 75% of required wheelchair seating spaces must be located in rows other than the front row of seats.</p> <table border="1" data-bbox="569 829 1058 1263"> <thead> <tr> <th rowspan="2">Fixed seats in a room or space</th> <th colspan="2">Wheelchair spaces Note 1</th> <th colspan="3">Grouping and location</th> <th rowspan="2">Spaces must represent range of seating provided Note 3</th> </tr> <tr> <th>Minimum spaces required</th> <th>1 additional space required per Note 2</th> <th>Min. single spaces</th> <th>Min. groups of 2 spaces</th> <th>Max. spaces in any other group</th> </tr> </thead> <tbody> <tr> <td>Up to 150</td> <td>3</td> <td>N/A</td> <td>1</td> <td>1</td> <td>N/A</td> <td>No</td> </tr> <tr> <td>151 to 800</td> <td>3</td> <td>50 seats in excess of 150 seats</td> <td>1</td> <td>1</td> <td>5</td> <td>No</td> </tr> <tr> <td>801 to 10 000</td> <td>16</td> <td>100 seats in excess of 800 seats</td> <td>2</td> <td>2</td> <td>5</td> <td>Yes</td> </tr> <tr> <td>More than 10 000</td> <td>108</td> <td>200 seats in excess of 10 000 seats</td> <td>5</td> <td>5</td> <td>10</td> <td>Yes</td> </tr> </tbody> </table> <p>► Table Notes</p>	Fixed seats in a room or space	Wheelchair spaces Note 1		Grouping and location			Spaces must represent range of seating provided Note 3	Minimum spaces required	1 additional space required per Note 2	Min. single spaces	Min. groups of 2 spaces	Max. spaces in any other group	Up to 150	3	N/A	1	1	N/A	No	151 to 800	3	50 seats in excess of 150 seats	1	1	5	No	801 to 10 000	16	100 seats in excess of 800 seats	2	2	5	Yes	More than 10 000	108	200 seats in excess of 10 000 seats	5	5	10	Yes	-	NA
Fixed seats in a room or space	Wheelchair spaces Note 1		Grouping and location			Spaces must represent range of seating provided Note 3																																					
	Minimum spaces required	1 additional space required per Note 2	Min. single spaces	Min. groups of 2 spaces	Max. spaces in any other group																																						
Up to 150	3	N/A	1	1	N/A	No																																					
151 to 800	3	50 seats in excess of 150 seats	1	1	5	No																																					
801 to 10 000	16	100 seats in excess of 800 seats	2	2	5	Yes																																					
More than 10 000	108	200 seats in excess of 10 000 seats	5	5	10	Yes																																					
D4D11: Swimming pools	<p>(1) Not less than 1 means of accessible water entry/exit in accordance with Specification 16 must be provided for each swimming pool required by D4D2 to be accessible.</p> <p>(2) An accessible entry/exit must be by means of—</p>	<p><u>Level 1</u> Communal space to be accessible. As lap pool in gym area is more than 40m in perimeter an accessible entry into the pool is required.</p>	DNC																																								

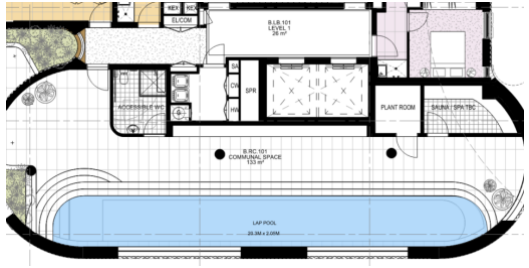
	<p>(a) a fixed or movable ramp and an aquatic wheelchair; or</p> <p>(b) a zero-depth entry and an aquatic wheelchair; or</p> <p>(c) a platform swimming pool lift and an aquatic wheelchair; or</p> <p>(d) a sling-style swimming pool lift.</p> <p>(3) Where a swimming pool has a perimeter of more than 70 m, at least one accessible water entry/exit must be provided by a means specified in (2)(a), (b) or (c).</p> <p>(4) Latching devices on gates and doors forming part of a swimming pool safety barrier need not comply with AS 1428.1.</p>	 <p>Redesign for further assessment. 'Still required'</p>	
D4D12: Ramps	<p>On an accessway—</p> <p>(a) a series of connected ramps must not have a combined vertical rise of more than 3.6 m; and</p> <p>(b) a landing for a step ramp must not overlap a landing for another step ramp or ramp.</p>	To be assessed prior to CC.	CRA
D4D13: Glazing on an accessway	<p>On an <i>accessway</i>, where there is no chair rail, handrail or transom, all frameless or fully glazed doors, sidelights and any glazing capable of being mistaken for a doorway or opening, must be clearly marked in accordance with AS 1428.1.</p>	To be assessed prior to CC.	CRA
Specification 15 – Braille and tactile signs			
S15C1: Scope	<p>This Specification sets out the requirements for the design and installation of braille and tactile signage as required by D3D26, D4D7 and Specification 27.</p>	-	Noted

<p>S15C2: Location of braille and tactile signs</p>	<p>Signs including symbols, numbering and lettering must be designed and installed as follows:</p> <ul style="list-style-type: none"> a) Braille and tactile components of a sign must be located not less than 1200 mm and not higher than 1600 mm above the floor or ground surface. b) Signs with single lines of characters must have the line of tactile characters not less than 1250 mm and not higher than 1350 mm above the floor or ground surface. c) Signs identifying rooms containing features or facilities listed in D4D7 must be located— <ul style="list-style-type: none"> (i) on the wall on the latch side of the door with the leading edge of the sign located between 50 mm and 300 mm from the architrave; and (ii) where (i) is not possible, the sign may be placed on the door itself. d) Signs identifying a door required by E4D5 to be provided with an exit sign must be located— <ul style="list-style-type: none"> (i) on the side that faces a person seeking egress; and (ii) on the wall on the latch side of the door with the leading edge of the sign located between 50 mm and 300 mm from the architrave; and (iii) where (ii) is not possible, the sign may be placed on the door itself. 	<p>To be assessed prior to CC.</p>	<p>CRA</p>
---	---	------------------------------------	------------

BCA Clause	Relevant Deemed-To-Satisfy Requirements	Comment	Status
S15C3: Braille and tactile sign specification	<ul style="list-style-type: none"> (1) Tactile characters must be raised or embossed to a height of not less than 1 mm and not more than 1.5 mm. (2) Title case must be used for all tactile characters, and— <ul style="list-style-type: none"> (a) upper case tactile characters must have a height of not less than 15 mm and not more than 55 mm, except that the upper-case tactile characters on a sign identifying a door required by E4D5 to be provided with an exit sign must have a height of not less than 20 mm and not more than 55 mm; and (b) lower case tactile characters must have a minimum height of 50% of the related upper-case characters. 	To be assessed prior to CC.	CRA

BCA Clause	Relevant Deemed-To-Satisfy Requirements	Comment	Status
	<ul style="list-style-type: none"> (3) Tactile characters, symbols, and the like, must have rounded edges. (4) The entire sign, including any frame, must have all edges rounded. (5) The background, negative space or fill of signs must be of matt or low sheen finish. (6) The characters, symbols, logos and other features on signs must be matt or low sheen finish. (7) The minimum letter spacing of tactile characters on signs must be 2 mm. (8) The minimum word spacing of tactile characters on signs must be 10 mm. (9) The thickness of letter strokes must be not less than 2 mm and not more than 7 mm. (10) Tactile text must be left justified, except that single words may be centre justified. (11) Tactile text must be Arial typeface. 		
S15C4: Luminance contrast	<p>The following applies to luminance contrast:</p> <ul style="list-style-type: none"> a) The background, negative space, fill of a sign or border with a minimum width of 5 mm must have a luminance contrast with the surface on which it is mounted of not less than 30%. b) Tactile characters, icons and symbols must have a minimum luminance contrast of 30% to the surface on which the characters are mounted. c) Luminance contrasts must be met under the lighting conditions in which the sign is to be located. 	To be assessed prior to CC.	CRA

BCA Clause	Relevant Deemed-To-Satisfy Requirements	Comment	Status
S15C5: Lighting	Braille and tactile signs must be illuminated to ensure luminance contrast requirements are met at all times during which the sign is required to be read.	To be assessed prior to CC.	CRA
S15C6: Braille	<p>The following applies to braille:</p> <ul style="list-style-type: none"> a) Braille must be grade 1 braille (uncontracted) in accordance with the criteria set out by the Australian Braille Authority. b) Braille must be raised and domed. c) Braille must be located 8 mm below the bottom line of text (not including descenders). d) Braille must be left justified. e) Where an arrow is used in the tactile sign, a solid arrow must be provided for braille readers. f) On signs with multiple lines of text and characters, a semicircular braille locator at the left margin must be horizontally aligned with the first line of braille text. 	To be assessed prior to CC.	CRA
Specification 16 – Accessible water entry/exit from swimming pools – not applicable			
Part E3 – Lift installations			
E3D1: Deemed-to-Satisfy Provisions	<p>(1) Where a Deemed-to-Satisfy Solution is proposed, Performance Requirements E3P1 to E3P4 are satisfied by complying with—</p> <ul style="list-style-type: none"> (a) E3D2 to E3D12; and (b) for a building containing an occupiable outdoor area, Part G6; and (c) for public transport buildings, Part I2. <p>(2) Where a Performance Solution is proposed, the relevant Performance Requirements must be determined in accordance with A2G2(3) and A2G4(3) as applicable.</p>	-	Noted

E3D6: Landings	Access and egress to and from lift well landings must comply with Parts D2, D3 and D4.	Refer to D4D2, D2D3 and D2D4.	DNC
E3D7: Passenger lift types and their limitations	<p>(1) In an accessible building, every passenger lift must be one of the following lift types, subject to the limitations (if any) of each lift type:</p> <ul style="list-style-type: none"> (a) There are no limitations on the use of electric passenger lifts, electrohydraulic passenger lifts or inclined lifts. (b) Stairway platform lifts must not— <ul style="list-style-type: none"> (i) be used to serve a space in a building accommodating more than 100 persons calculated according to D2D18; or (ii) be used in a high traffic public use area such as a theatre, cinema, auditorium, transport interchange, shopping centre or the like; or (iii) be used where it is possible to install another type of passenger lift; or (iv) connect more than 2 storeys; or (v) where more than 1 stairway lift is installed, serve more than 2 consecutive storeys; or (vi) when in the folded position, encroach on the minimum width of a stairway required by D2D8 to D2D11. (c) A low-rise platform lift must not travel more than 1000 mm. (d) A low-rise, low-speed constant pressure lift must not— <ul style="list-style-type: none"> (i) for an enclosed type, travel more than 4 m; or (ii) for an unenclosed type, travel more than 2 m; or (iii) be used in a high traffic public use areas in buildings such as a theatre, cinema, auditorium, 	To be further assessed prior to CC.	CRA

	<p>transport interchange, shopping complex or the like.</p> <p>(c) A small-sized, low-speed automatic lift must not travel more than 12 m.</p> <p>(12) A passenger lift referred to in (1) must not rely on a constant pressure device for its operation if the lift car is fully enclosed.</p>		
--	---	--	--

BCA Clause	Relevant Deemed-To-Satisfy Requirements	Comment	Status
<p>E3D8: Accessible features required for passenger lifts</p>	<p>In an accessible building, every passenger lift must have the following features where applicable:</p> <ul style="list-style-type: none"> (a) A handrail complying with the provisions for a mandatory handrail in AS 1735.12 for all lifts except— <ul style="list-style-type: none"> (i) a stairway platform lift; and (ii) a low-rise platform lift. (b) Lift floor dimensions of not less than 1400 mm wide x 1600 mm deep for all lifts which travel more than 12 m. (c) Lift floor dimensions of not less than 1100 mm wide x 1400 mm deep for all lifts which travel not more than 12 m, except a stairway platform lift. (d) Lift floor dimensions of not less than 810 mm wide x 1200 mm deep for a stairway platform lift. (e) Minimum clear door opening complying with AS 1735.12 for all lifts except a stairway platform lift. (f) Passenger protection system complying with AS 1735.12 for all lifts with power-operated doors. (g) Lift landing doors at the upper landing for all lifts except a stairway platform lift. (h) Lift car and landing control buttons complying with AS 1735.12 for all lifts except— <ul style="list-style-type: none"> (i) a stairway platform lift; and (ii) a low-rise platform lift. (a) Lighting in accordance with AS 1735.12 for all 	<p>Refer to D4D2 an D2D4.</p>	<p>DNC</p>

	<p>enclosed lift cars.</p> <p>(b) For all lifts serving more than 2 levels—</p> <p>(i) automatic audible information within the lift car to identify the level each time the car stops; and</p> <p>(ii) audible and visual indication at each lift landing to indicate the arrival of the lift car; and</p> <p>(iii) audible information and audible indication required by (i) and (ii) is to be provided in a range of between 20 - 80 dB(A) at a maximum frequency of 1500 Hz.</p> <p>(c) Emergency hands-free communication, including a button that alerts a call centre of a problem and a light to signal that the call has been received, for all lifts except a stairway platform lift.</p>		
--	--	--	--

Part F4 – Sanitary and other facilities

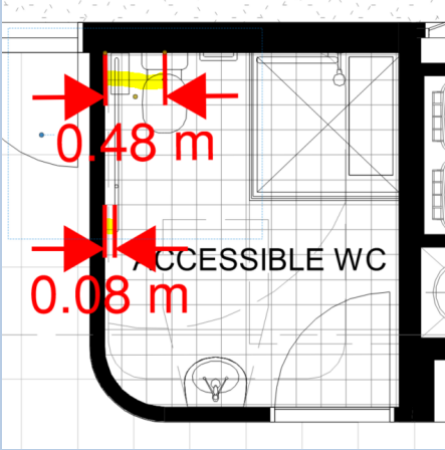
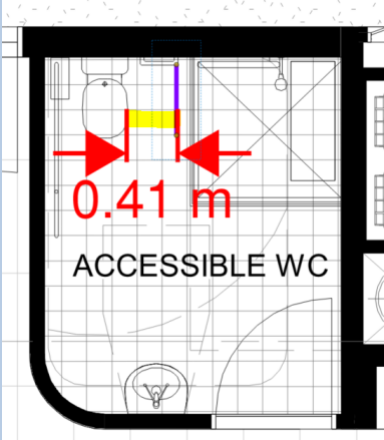
BCA Clause	Relevant Deemed-To-Satisfy Requirements	Comment	Status
Part F4 – Sanitary and other facilities			
<p>F4D5: Accessible Sanitary Facilities</p>	<p>In a building required to be <i>accessible</i>—</p> <ul style="list-style-type: none"> (a) accessible unisex sanitary compartments must be provided in accessible parts of the building in accordance with F4D6. (b) accessible unisex showers must be provided in accordance with F4D7; and (c) at each bank of toilets where there is one or more toilets in addition to an accessible unisex sanitary compartment at that bank of toilets, not less than one sanitary compartment suitable for a person with an ambulant disability for use by males and not less than one sanitary compartment suitable for a person with an ambulant disability for use by females, each in accordance with AS 1428.1, must be provided; and (d) an accessible unisex sanitary compartment must contain a closet pan, washbasin, shelf or bench top and adequate means of disposal of sanitary products; and (e) the circulation spaces, fixtures and fittings of all accessible sanitary facilities provided in accordance with F4D6 and F4D7 must comply with the requirements of AS 1428.1; and (f) an accessible unisex sanitary facility must be located so that it can be entered without crossing an area reserved for one sex only; and (g) where two or more of each type of accessible unisex sanitary facility are provided, the number of left and right handed mirror image facilities must be provided as evenly as possible; and 	<p><u>Level 1 – Accessible WC</u> Doesn't comply with the requirements of AS1428.1.</p>   <p><u>Basement 03 – Accessible WC</u> Doesn't comply with the requirements of AS1428.1.</p>	<p>CRA</p>

(h) where male sanitary facilities are provided at a separate location to female sanitary facilities, accessible unisex sanitary facilities are only required at one of those locations; and

(i) an accessible unisex sanitary compartment or an accessible unisex shower need not be provided on a storey or level that is not required by D4D4(f) to be provided with a passenger lift or ramp complying with AS 1428.1.

Australian Standard Clauses **Relevant Australian Standard Clauses to D4D4**

Clause 15 – Sanitary Facilities

15 Sanitary Facilities
15.1 General

The facilities described in this Clause may be used as individual modules, in mirror image configurations or in a combined form, as specified in Clause 15.6.

15.2 Accessible unisex sanitary facilities
15.2.1 Water Taps

Water taps shall comply with the following:

- (a) Taps shall have lever handles, sensor plates, or other similar controls.
- (b) Lever handles shall have not less than 50 mm clearance from an adjacent surface.
- (c) Where separate taps are provided for hot and cold water, the hot water tap shall be placed to the left of the cold water tap for horizontal configurations, or above the cold water tap for vertical configurations.
- (d) Where hot water is provided, the water shall be delivered through a mixing spout.

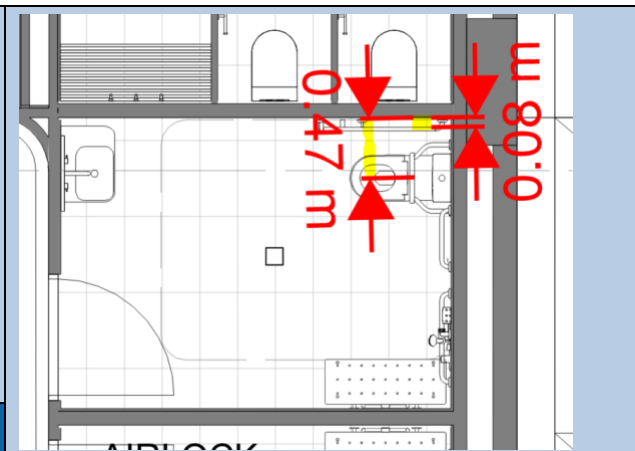

Ambulant toilet to comply with Part 16 of the AS1428.1.

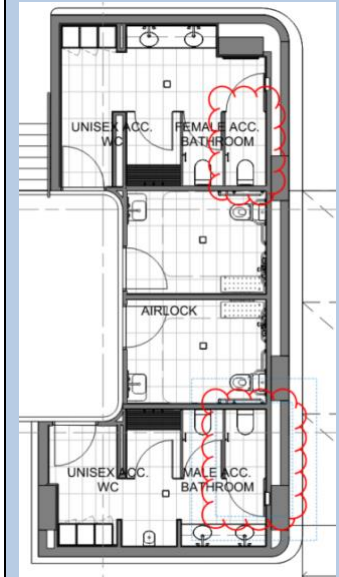

Redesign for further assessment. 'Still required'

15.2.2 WC pan clearances

WC pan clearances, including set-out, seat height and seat width shall be as shown in Figure 38.

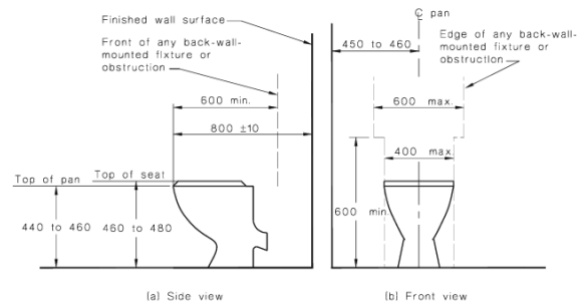

NOTES:

1. For the purpose of dimensioning, the front of the WC pan has been taken as the datum plane.
2. The dimension of 800 ±10 mm from the front of the WC pan to the wall is a critical dimension.

15.2.3 Seat

A toilet seat shall be provided on accessible toilets. The toilet seat shall—

- (a) be of the full-round type, (i.e., not open fronted) and with minimal contours to the top surface;
- (b) be securely fixed in position when in use;
- (c) have seat fixings that create lateral stability for the seat when in use;
- (d) be load-rated to 150 kg; and
- (e) have a minimum luminance contrast of 30% with the background (e.g., pan, wall or floor against which it is viewed).

Level 11 – Building A

If the proposed toilet to be accessible, ensure it complies with the requirements of AS1428.1.

Note

15.2.4 Backrest

A backrest shall be provided on accessible toilets. The backrest shall—

- (a) be capable of withstanding a force in any direction of 1100 N;
- (b) have a height, at the lower edge of backrest to the top of the WC pan, of 120 mm to 150 mm, as shown in Figure 39(a);
- (c) have a vertical height of 150–200 mm and a width of 350–400 mm, as shown in Figure 39(a); and
- (d) the front edge of the centre of the backrest be positioned to achieve an angle
- (e) of between 95° to 100° back from the seat hinge (Figure 39(b)).

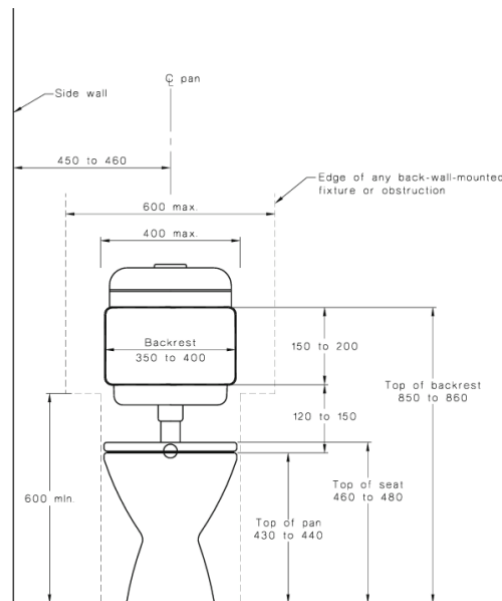

(a) Front view

DIMENSIONS IN MILLIMETRES

FIGURE 39 (in part) WATER CLOSET INSTALLATION

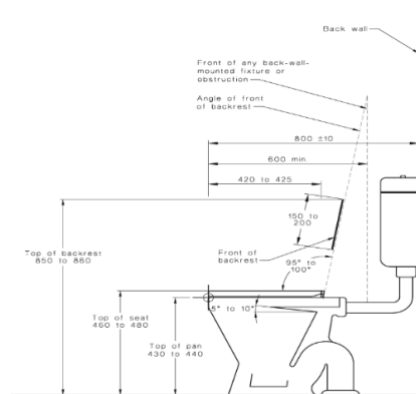

(b) Side view
DIMENSIONS IN MILLIMETRES

FIGURE 39 (in part) WATER CLOSET INSTALLATION

15.2.5 Flushing control

Flushing controls shall be user activated, either hand operated or automatic. Where hand-operated flushing controls are used, they shall be located within the zone shown in Figure 40, or centred on the centre-line of the toilet, wholly within the vertical limits of that zone. The position of the flushing control within this zone shall not be within the area required for any grabrails. The flushing control shall be proud of the surface and shall activate the flush before the button becomes level with the surrounding surface.

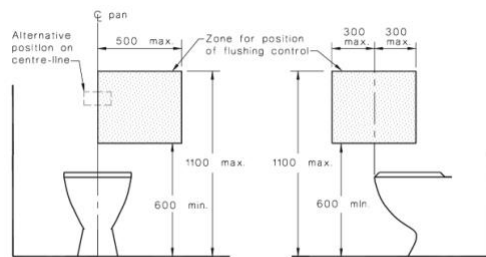

(a) Back wall (b) Side wall
DIMENSIONS IN MILLIMETRES

FIGURE 40 ZONE FOR POSITION OF FLUSHING CONTROL

15.2.6 Toilet paper dispenser

The outlet for the toilet paper dispenser shall be located within the zone specified in Figure 41.

The toilet paper dispenser shall not encroach upon the clearance space required around the grabrail specified in Clause 15.2.7.

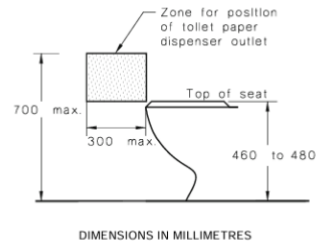

FIGURE 41 ZONE FOR POSITION OF TOILET PAPER DISPENSER

15.2.7 Grabrails

Where a concealed or high-level cistern or flush valve is used, a continuous grabrail, as specified in Clause 17, shall be provided across the rear wall and side wall nearest the WC pan, as shown in Figure 42. Where a low-level non-concealed cistern or flush valve is used, the grabrail shall be terminated at each side of the cistern, as shown in Figure 42.

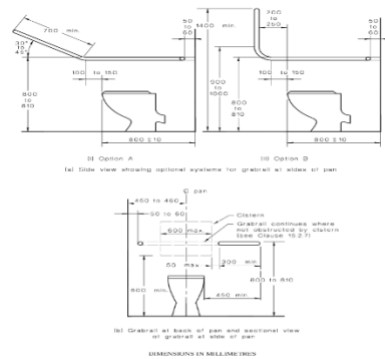

FIGURE 42 POSITIONS OF GRABRAILS IN WATER CLOSETS

15.2.8 Circulation space

15.2.8.1 General

For each WC, the unobstructed circulation space from the finished floor to a height of not less than 2000 mm shall be as shown in Figure 43, except for the following, which are allowed to intrude into the circulation space:

- (a) The toilet paper dispenser (see Clause 15.2.6).
- (b) Grabrails (see Clause 15.2.7).
- (c) Washbasin limited to 100 mm intrusion as shown in Figure 43.
- (d) Hand dryers and towel dispensers.
- (e) Soap dispensers (see Clause 15.4.3).
- (f) Shelves (see Clause 15.4.2).
- (g) Wall cabinets, where provided, which shall not protrude more than 150 mm into the circulation space. The mounting of wall cabinets shall be at least 900 mm above floor level and the top shelf shall be a maximum of 1250 mm above floor level.
- (h) Clothes hanging devices (see Clause 15.4.4).
- (i) Portable sanitary disposal unit as shown in Figure 43.
- (j) Other wall mounted fixtures, such as dispensing units and sharps disposal units, which shall have 900 mm minimum height clearance from the finished floor level and a maximum projection of 150 mm from finished wall surface.

The overlapping of circulation spaces shall be in accordance with Clause 15.6.

15.2.8.2 Baby change tables

Where installed, baby change tables shall—

- (a) not encroach into the circulation space of any other toilet facility when in the folded position; and
- (b) have a maximum height of 820 mm and a minimum clearance underneath of 720 mm when in the open position.

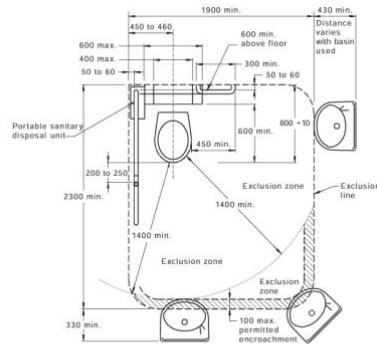

LEGEND
 --- Circulation space line
 NOTE: This circulation space may overlap any other circulation spaces specified in this Standard.
 DIMENSIONS IN MILLIMETRES
 FIGURE 43 CIRCULATION SPACE FOR WC PAN—RIGHT-HAND TRANSFER
 (LEFT-HAND TRANSFER IS MIRROR REVERSED)

15.2.9 WC doors

WC doors may be either hinged or sliding. WC doors shall comply with the following:

- (a) Outward-opening doors shall have a mechanism that holds the door in a closed position without the use of a latch.
- (b) Doors shall be provided with an in-use indicator and a bolt or catch. Where a snib catch is used, the snib handle shall have a minimum length of 45 mm from the centre of the spindle. In an emergency, the latch mechanism shall be openable from the outside.
- (c) The force required to operate the door shall be in accordance with Clause 13.5.2(e).
- (d) Door handles and hardware shall be in accordance with Clause 13.5.

15.2.10 Washbasins for unisex accessible sanitary facilities

A hand-washing facility shall be provided inside the toilet cubicle and shall form part of the accessible unisex facility (see Clause 15.3).

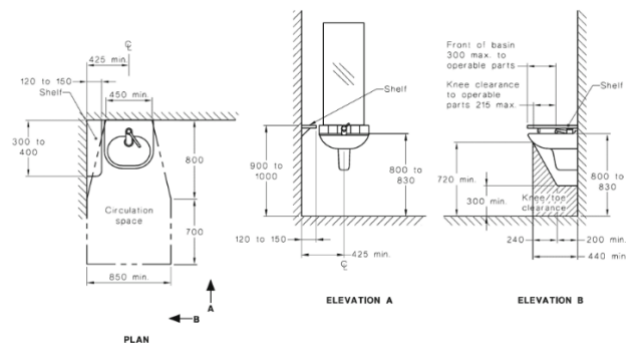

DIMENSIONS IN MILLIMETRES
FIGURE 44(B) WALL-MOUNTED WASHBASIN INSTALLATION—OTHER THAN FOR SOLE-OCCUPANCY UNIT

15.3.2 Accessible sole occupancy units

Accessible sole occupancy units shall have the following characteristics:

- (a) The projection of the washbasin from the wall and the position of taps, bowl and drain outlet shall be determined in accordance with Figure 45.
- (b) Water supply pipes and waste outlet pipes shall not encroach on the required clear space under the washbasin, as shown in Figure 45.
- (c) For each washbasin fixture, the unobstructed circulation space shall be in accordance with Figure 46. The washbasin fixture and its fittings are the only fixtures permitted in this space.
- (d) Shelf space shall be provided adjacent to the washbasin in one of the following ways:
 - (i) As a vanity top—
 - (A) at a height of 800 mm to 830 mm above the floor;
 - (B) with a minimum width of 120 mm beside the basin;
 - (C) with a minimum depth of 300 mm from the front to the rear wall; and

(D) with no encroachment into any knee and toe clearance space for a minimum width of 850 mm centred on the basin.

(ii) As a separate fixture—

(A) within any circulation space at a height of 900 mm to 1000 mm with a minimum underside clearance of 850 mm for a width of 120 mm to 150 mm and length of 300 mm to 400 mm; and

(B) external to all circulation spaces at a height of 800 mm to 1000 mm with a minimum width of 120 mm and minimum length of 400 mm.

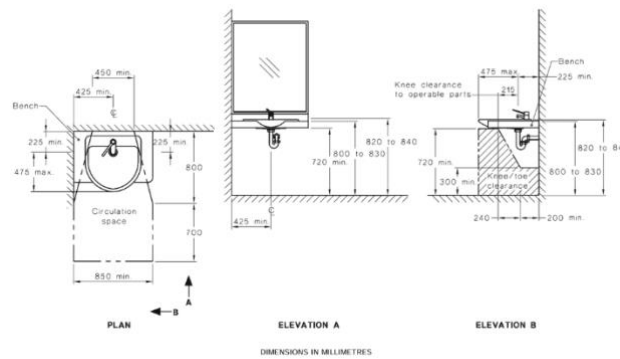
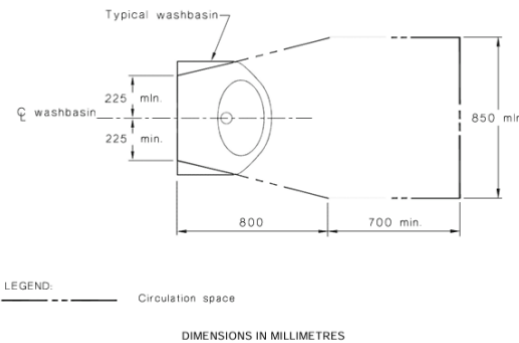

FIGURE 45 WASHBASIN FOR ACCESSIBLE SOLE-OCCUPANCY UNIT



LEGEND: - - - - - Circulation space

FIGURE 46 CIRCULATION SPACE FOR WASHBASINS

15.4 Fixtures and fittings within a sanitary facility

15.4.1 Mirrors

In all sanitary facilities, the mirror shall be located either above or adjacent to the washbasin.

Where provided, a vertical mirror with a reflective surface not less than 350 mm wide shall extend from a height of not more than 900 mm to a height of not less than 1850 mm above the plane of the finished floor. Where provided, a second vertical mirror shall extend from a height of not less than 600 mm to a height of not less than 1850 mm above the plane of the finished floor.

NOTE: Angled or tilted mirrors should not be used since they do not work for all users or accessible facilities.

In an accessible sole occupancy unit, the mirror shall be centred over the washbasin.

15.4.2 Shelves

Shelf space shall be provided adjacent to the washbasin in one of the following ways:

- (a) As a vanity top at a height of 800 mm to 830 mm and a minimum width of 120 mm and depth of 300 mm to 400 mm without encroaching into any circulation space.
- (b) As a separate fixture—
 - (i) within any circulation space at a height of 900 mm to 1000 mm with a width of 120 mm to 150 mm and length of 300 mm to 400 mm; and
 - (ii) external to all circulation spaces at a height of 790 mm to 1000 mm with a minimum width of 120 mm and minimum length of 400 mm.

15.4.3 Soap dispensers, towel dispensers and similar fittings

Where provided, soap dispensers, towel dispensers, hand dryers and similar fittings shall be operable by one hand, and shall be installed with the height of their

operative component or outlet not less than 900 mm and not more than 1100 mm above the plane of the finished floor, and no closer than 500 mm from an internal corner.

15.4.4 Clothes-hanging devices

A clothes-hanging device shall be installed 1200 mm to 1350 mm above the plane of the finished floor and not less than 500 mm out from any internal corner.

15.4.5 Sanitary disposal unit

Where provided, the sanitary disposal unit shall be located as follows:

- (a) Portable unit as shown in Figure 43.
- (b) Recessed unit within 500 mm from the pan.

15.4.6 Switches and general purpose outlets

Where provided near the washbasin, switches and general purpose outlets shall be located in accordance with Clause 14 and as close to the shelf or worktop as practicable.

15.5 Showers

15.5.1 General

The general requirements for showers are as follows:

- (a) Shower recesses and the circulation space for each shower recess from the finished floor to a height of not less than 900 mm shall be as shown in Figure 47. Grabrails, shower hose fittings; taps, soap holder, shelf (if provided) and the folding seat are the only fixtures permitted in these spaces.
- (b) Shower recess fittings shall be provided as shown in Figures 47 and 48. Not less than two clothes-hanging devices, as specified in Clause 15.4.4, shall be fitted outside the shower recess. One such device shall be located within 400 ± 10 mm and the other within 600 ± 10 mm of the folding seat.

15.5.3 Opening shower screens

The means of screening a shower recess shall be either by a curtain or a door system that maintains the required circulation space of 1600 mm x 2350 mm.

15.5.4 Grabrails

Grabrails, as specified in Clause 17, shall be fixed on the walls in the positions shown in Figures 47 and 48. Taps, soap holder and shower head support grabrail, as shown in Figures 47 and 48 may encroach into the 600 mm clearance above the grabrail required by Clause 17(e).

15.5.5 Shower head support grabrail

A shower head support grabrail, as specified in Clause 17, shall be fixed on the wall in the position shown in Figure 48.

15.5.6 Shower head

A hand-held shower head shall be provided, which shall have a flexible hose of a minimum length of 1500 mm.

An adjustable shower head holder shall be provided to support the shower head and shall—

- (a) be installed on the shower head holder support grabrail as shown in Figure 48;
- (b) allow the graspable portion of the shower head to be positioned at various angles and heights;
- (c) allow the graspable portion of the shower head to be located at heights between 1000 mm and 1800 mm above the plane of the finished floor; and
- (d) allow access and adjustment from a seated position.

15.5.7 Soap holder

The soap holder shall be located within the zone shown in Figure 48.

15.5.8 Taps

Taps, as specified in Clause 15.2.1, shall be located within the zone shown in Figure 48.

15.5.9 Folding seat

A foldable seat shall be provided inside the shower recess, as shown in Figures 47 and 48, and shall—

- (a) be self-draining;
- (b) be slip-resistant;
- (c) have front corners that are rounded to a radius of 10 to 15 mm;
- (d) have top edges that are rounded with a minimum radius of 2 to 3 mm; and
- (e) shall fold in an upwards direction and when folded the grabrail shall be accessible.

Where drainage is provided by holes or slots in single unit seats or by gaps between slats in compound seats, the diameter of the holes, the width of the slots and the gaps between slats shall be between 4 to 6 mm.

The fastenings, materials and construction of the seat shall be able to withstand a force of 1100 N applied at any position and in any direction without failing or loosening of fastenings.

15.6 Circulation spaces in accessible sanitary facilities

The circulation spaces in accessible sanitary facilities shall be in accordance with Clause 15.2.8 and Figures 43 to 47 and 50. The following also apply:

- (a) Circulation spaces, including door circulation spaces, may be overlapped.
- (b) With the following exceptions, fixtures shall not encroach into circulation spaces:
 - (i) The washbasin may encroach into the WC circulation space in accordance with Figure 43.
 - (ii) The washbasin may encroach into the shower

circulation space in accordance with Figure 50.

- (iii) The washbasin may encroach into the circulation space of the door in accordance with Figures 51(A) and 51(B).

NOTE: An example of an overlapping circulation space in a sanitary compartment is shown in Figure 52.

Clearances beneath the washbasin shall be in accordance with Clause 15.3 and door circulation spaces shall be in accordance with Clause 13.3 modified in accordance with Item (b)(ii) or (b)(iii) of this Clause, if appropriate.

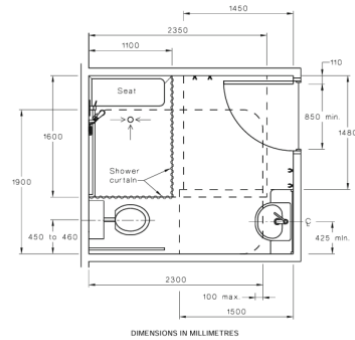

FIGURE 50 SANITARY COMPARTMENT SHOWING OVERLAP OF WASHBASIN FIXTURE INTO SHOWER CIRCULATION SPACE

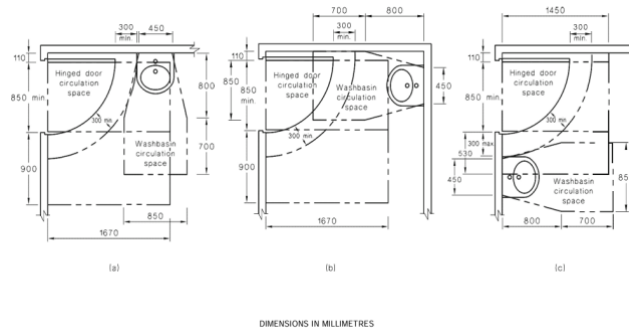
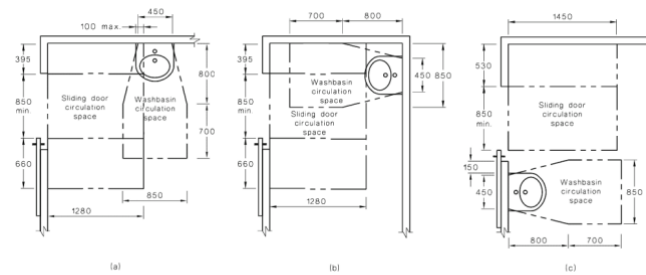
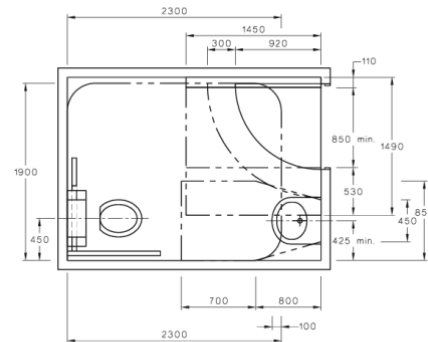

FIGURE 51(A) ALLOWABLE ENCRoACHMENT OF A WASHBASIN INTO HINGED DOOR CIRCULATION SPACE



DIMENSIONS IN MILLIMETRES

FIGURE 51(B) OVERLAP OF WASHBASIN FIXTURE INTO DOOR CIRCULATION SPACE WHERE WASHBASIN IS LOCATED OPPOSITE A SLIDING DOOR



LEGEND
 - - - - - Circulation space

DIMENSIONS IN MILLIMETRES

FIGURE 52 EXAMPLE OF OVERLAPPING CIRCULATION SPACES IN A SANITARY COMPARTMENT

16 SANITARY COMPARTMENT FOR PEOPLE WITH AMBULANT DISABILITIES

16.1 General

Sanitary compartment for people with ambulant disabilities shall be in accordance with Figures 53(A) and 53(B).

16.2 Grabrails

Grabrails shall be installed in accordance with Clause 17 and Figure 53(A).

16.3 Doors

Doors to sanitary compartments for people with ambulant disabilities shall have openings with a minimum clear width of 700 mm, and shall comply with Figure 53(B).

Doors shall be provided with an in-use indicator and a bolt or catch. Where a snib catch is used, the snib handle shall have a minimum length of 45 mm from the centre of the spindle. In an emergency, the latch mechanism shall be openable from the outside.

16.4 Signage

Sanitary compartment for people with ambulant disabilities shall be identified by symbol or words, as specified in Clause 8.

16.5 Coat hook

A coat hook shall be provided within the sanitary compartment and at a height between 1350 mm to 1500 mm from the floor.

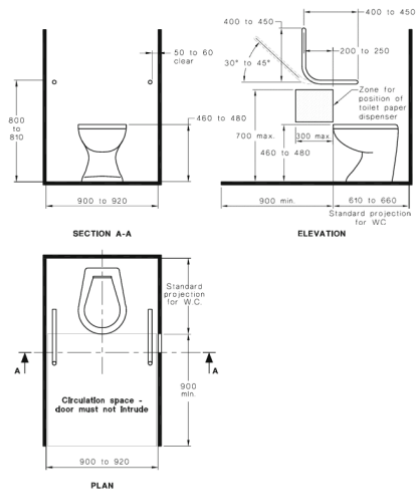

FIGURE 53(A) SANITARY COMPARTMENT FOR PEOPLE WITH AMBULANT DISABILITIES—PLAN AND ELEVATION

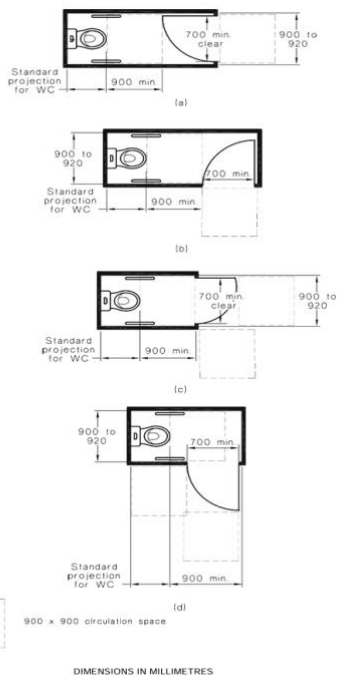

FIGURE 53(B) SANITARY COMPARTMENT FOR PEOPLE WITH AMBULANT DISABILITIES—DOORWAY OPTIONS

F4D12: Accessible adult change facilities

Not applicable

NA

Annexure B – Design Documentation

This report has been prepared based on the following design documentation.

Architectural plans prepared by SJB Architects			
Drawing no.	Revision	Date	Title
DA-0001	2	28/02/2025	COVER SHEET 2
DA-0002	2	28/02/2025	BASIX CERTIFICATE 2
DA-0010	2	28/02/2025	APARTMENT SCHEDULE 2
DA-0101	2	28/02/2025	SITE LOCATION PLAN 2
DA-0105	2	28/02/2025	SITE ANALYSIS
DA-1000	3	28/02/2025	GA_BASEMENT 04
DA-1001	3	28/02/2025	GA_BASEMENT 03
DA-1002	3	28/02/2025	GA_BASEMENT 02
DA-1003	3	28/02/2025	GA_BASEMENT 01
DA-1011	3	28/02/2025	GA_GROUND FLOOR PLAN
DA-1012	3	28/02/2025	GA_LEVEL 01
DA-1013	3	28/02/2025	GA_LEVEL 02
DA-1014	3	28/02/2025	GA_LEVEL 03
DA-1015	3	28/02/2025	GA_LEVEL 04
DA-1016	3	28/02/2025	GA_LEVEL 05
DA-1017	3	28/02/2025	GA_LEVEL 06
DA-1018	3	28/02/2025	GA_LEVEL 07
DA-1019	3	28/02/2025	GA_LEVEL 08
DA-1020	3	28/02/2025	GA_LEVEL 09
DA-1021	3	28/02/2025	GA_LEVEL 10
DA-1022	3	28/02/2025	GA_LEVEL 11
DA-1023	3	28/02/2025	GA_LEVEL 12

DA-1024	3	28/02/2025	GA_LEVEL 13
DA-1025	3	28/02/2025	GA_LEVEL 14
DA-1026	3	28/02/2025	GA_LEVEL 15
DA-1027	3	28/02/2025	GA_LEVEL 16
DA-1028	3	28/02/2025	GA_LEVEL 17
DA-1029	3	28/02/2025	GA_ROOF PLAN
DA-1051	2	28/02/2025	TYP_ADAPTABLE PLANS 2
DA-1052	2	28/02/2025	TYP_ADAPTABLE PLANS 2
DA-1053	2	28/02/2025	TYP_ADAPTABLE PLANS
DA-1401	3	28/02/2025	ELEVATION – NORTH
DA-1402	3	28/02/2025	ELEVATION - EAST
DA-1403	3	28/02/2025	ELEVATION - SOUTH
DA-1404	3	28/02/2025	ELEVATION – WEST
DA-1424	2	28/02/2025	ELEVATION_BLD A_PODIUM EAST 2
DA-1425	2	28/02/2025	ELEVATION_BLD B_PODIUM SOUTH 2
DA-1426	2	28/02/2025	ELEVATION_BLD B_PODIUM WEST 2
DA-1428	2	28/02/2025	ELEVATION_BLD B_PODIUM EAST
DA-1501	1	28/02/2025	SECTION - A
DA-1502	1	28/02/2025	SECTION – B
DA-1610	1	28/02/2025	DETAIL SECTION - BUILDING A BASEMENT 04 - LVL 08 (TYP) 1
DA-1611	1	28/02/2025	DETAIL SECTION - BUILDING B BASEMENT 03 - LVL 08 (TYP) 1
DA-1810	2	28/02/2025	STORAGE PLAN 2
DA-4420	1	28/02/2025	TYPICAL APARTMENT TYPES 1
DA-4425	1	28/02/2025	TYPICAL APARTMENT TYPES SCHEDULES 1
DA-6001	2	28/02/2025	ANALYSIS - SOLAR 2
DA-6002	2	28/02/2025	ANALYSIS - SOLAR 2
DA-6003	2	28/02/2025	ANALYSIS - SOLAR 2

DA-6004	2	28/02/2025	ANALYSIS - SOLAR 2
DA-6010	2	28/02/2025	ANALYSIS - CROSS VENTILATION 2
DA-6011	2	28/02/2025	ANALYSIS - CROSS VENTILATION 2
DA-6012	2	28/02/2025	ANALYSIS - CROSS VENTILATION 2
DA-6013	2	28/02/2025	ANALYSIS - CROSS VENTILATION 2
DA-6020	2	28/02/2025	ANALYSIS - DEEP SOIL CALC / COMMUNAL OPEN SPACE 2
DA-6030	2	28/02/2025	ANALYSIS - HEIGHT PLANE DIAGRAM 2
DA-6050	2	28/02/2025	ANALYSIS - SHADOW DIAGRAMS - MID WINTER MORNING 2
DA-6051	2	28/02/2025	ANALYSIS - SHADOW DIAGRAMS - MID WINTER AFTERNOON 2
DA-6052	2	28/02/2025	DA-6052 ANALYSIS - 3D SHADOW WINTER SUN PATH 9AM-12PM SOLAR VIEWS 2
DA-6053	2	28/02/2025	ANALYSIS - 3D SHADOW WINTER SUN PATH 1PM-3PM SOLAR VIEWS 2
DA-6054	1	28/02/2025	ANALYSIS - SHADOW DIAGRAMS - MID AUTUMN MORNING 1
DA-6055	1	28/02/2025	ANALYSIS - SHADOW DIAGRAMS - MID AUTUMN AFTERNOON 1
DA-6056	1	28/02/2025	ANALYSIS - SHADOW DIAGRAMS - MID SPRING MORNING 1
DA-6057	1	28/02/2025	ANALYSIS - SHADOW DIAGRAMS - MID SPRING AFTERNOON 1
DA-6058	1	28/02/2025	ANALYSIS - SHADOW DIAGRAMS - MID SUMMER MORNING 1
DA-6059	1	28/02/2025	ANALYSIS - SHADOW DIAGRAMS - MID SUMMER AFTERNOON 1
DA-6061	2	28/02/2025	ANALYSIS - OPERABLE WINDOWS + VENTILATION 2
DA-6062	2	28/02/2025	ANALYSIS - INLET/OUTLET OPENINGS + VENTILATION 2
DA-6101	2	28/02/2025	ANALYSIS - AREA PLANS GFA 2
DA-6102	2	28/02/2025	ANALYSIS - AREA PLANS GFA 2
DA-6103	2	28/02/2025	ANALYSIS - AREA PLANS GFA 2
DA-6110	2	28/02/2025	ANALYSIS - AFFORDABLE AREA PLAN 2
DA-9520	2	28/02/2025	PUBLIC SPACE - PLANNING AGREEMENT 2
DA-9610	1	28/02/2025	BASEMENT RAMP- SECTION