



# DECMIL GROUP LIMITED

# SUNRAYSIA SOLAR FARM

# CONCEPT DESIGN OF ENTRANCE TRACK

## 61-35722

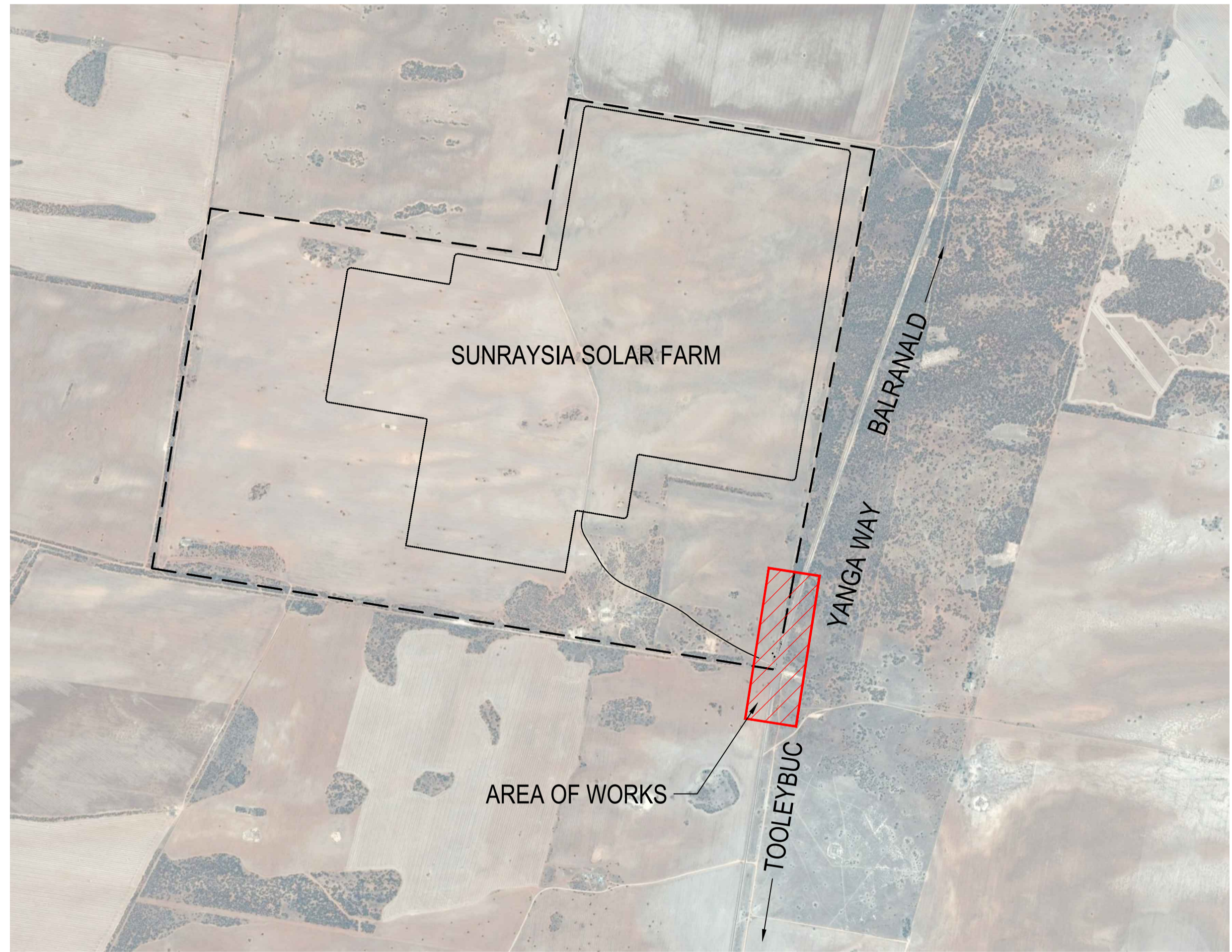
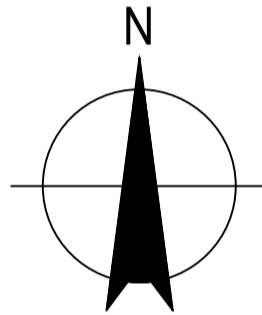

LOCATION MAP  
NTS

DRAWING LIST

DRG No.	DRAWING TITLE
61-35722-G001	COVER SHEET, LOCATION MAP AND DRAWING LIST
61-35722-C001	ROAD INTERSECTION - ACCESS TO SOLAR FARM
61-35722-C002	TRUCK VEHICLE TURN PATHS - LEFT TURN PATH
61-35722-C003	TRUCK VEHICLE TURN PATHS - RIGHT TURN PATH
61-35722-C004	TYPICAL SECTION

**CONCEPT DESIGN**

No	Revision	Note: * indicates signatures on original issue of drawing or last revision of drawing	Drawn	Job Manager	Project Director	Date
B	ISSUED TO CLIENT FOR REVIEW		AGV			
A	ISSUED TO CLIENT FOR REVIEW		EAS	PT*	JV*	29.01.18



**DO NOT SCALE**

GHD Pty Ltd  
Conditions of Use.  
This document may only be used by GHD's client (and any other person who GHD has agreed can use this document) for the purpose for which it was prepared and must not be used by any other person or for any other purpose.

Drawn	E. SANTOS	Designer	J. TIU
Drafting Check	M. MANLAPIT*	Design Check	G. DOUGHERTY*
Approved (Project Director)	J. VAESEN*		
Date	29.01.18		
Scale	NTS		

Client	DECMIL GROUP LIMITED		
Project	SUNRAYSIA ENTRANCE TRACK DESIGN		
Title	COVER SHEET, LOCATION MAP AND DRAWING LIST		
Original Size	A1	Drawing No:	61-35722-G001
Rev:	B		

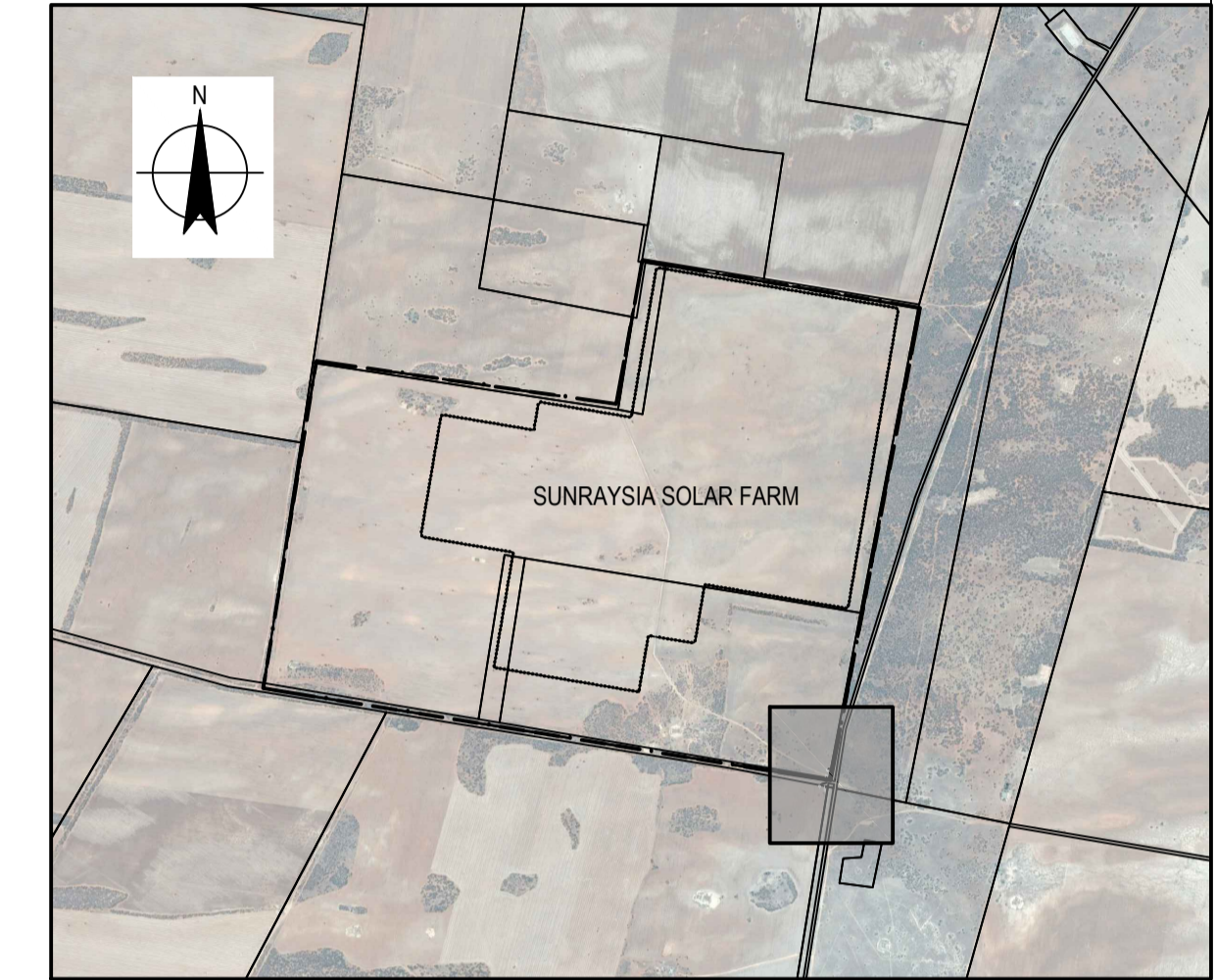
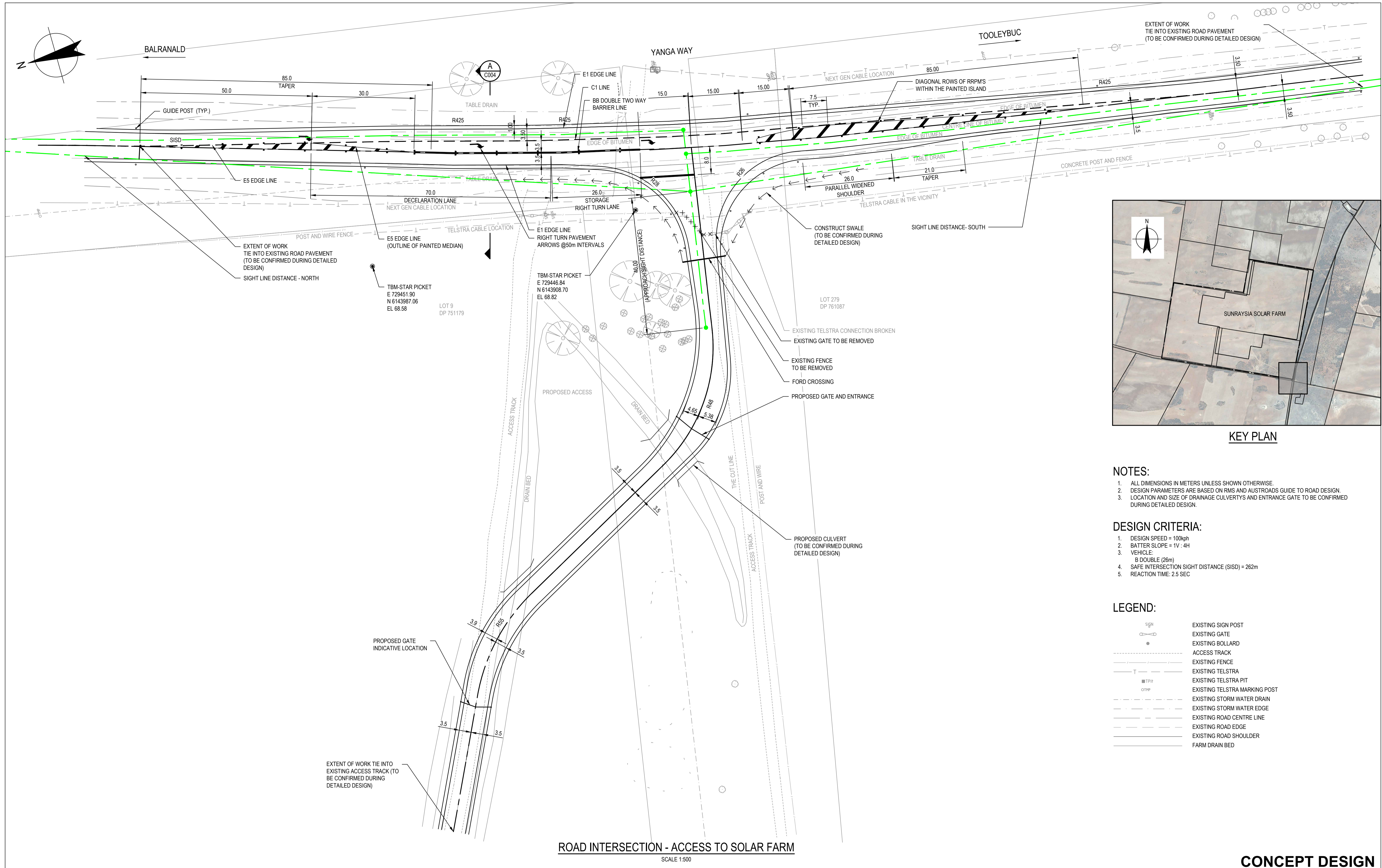

KEY PLAN

NOTES:

1. ALL DIMENSIONS IN METERS UNLESS SHOWN OTHERWISE.
2. DESIGN PARAMETERS ARE BASED ON RMS AND AUSTRROADS GUIDE TO ROAD DESIGN.
3. LOCATION AND SIZE OF DRAINAGE CULVERTS AND ENTRANCE GATE TO BE CONFIRMED DURING DETAILED DESIGN.

DESIGN CRITERIA:

1. DESIGN SPEED = 100kph
2. BATTER SLOPE = 1V : 4H
3. VEHICLE:  
B DOUBLE (26m)
4. SAFE INTERSECTION SIGHT DISTANCE (SISD) = 262m
5. REACTION TIME: 2.5 SEC

LEGEND:

	EXISTING SIGN POST
	EXISTING GATE
	EXISTING BOLLARD
	ACCESS TRACK
	EXISTING FENCE
	EXISTING TELSTRA
	EXISTING TELSTRA PIT
	EXISTING TELSTRA MARKING POST
	EXISTING STORM WATER DRAIN
	EXISTING STORM WATER EDGE
	EXISTING ROAD CENTRE LINE
	EXISTING ROAD EDGE
	EXISTING ROAD SHOULDER
	FARM DRAIN BED

CONCEPT DESIGN

B	REISSUED TO CLIENT FOR REVIEW	AGV			
A	ISSUED TO CLIENT FOR REVIEW	EAS	PT*	JV*	29.01.18
No	Revision	Note: * indicates signatures on original issue of drawing or last revision of drawing	Drawn	Job Manager	Project Director



**DO NOT SCALE**  
 GHD Pty Ltd  
 Conditions of Use.  
 This document may only be used by GHD's client (and any other person who GHD has agreed can use this document) for the purpose for which it was prepared and must not be used by any other person or for any other purpose.

Drawn	E. SANTOS	Designer	J. TIU
Drafting Check	M. MANLAPIT*	Design Check	G. DOUGHERTY*
Approved (Project Director)	J. VAESSEN*	Date	29.01.18
Scale	1:500	This Drawing must not be used for Construction unless signed as Approved	

Client	DECMIL GROUP LIMITED
Project	SUNRAYSIA ENTRANCE TRACK DESIGN
Title	ROAD INTERSECTION ACCESS TO SOLAR FARM
Original Size	A1
Drawing No:	61-35722-C001
Rev:	B

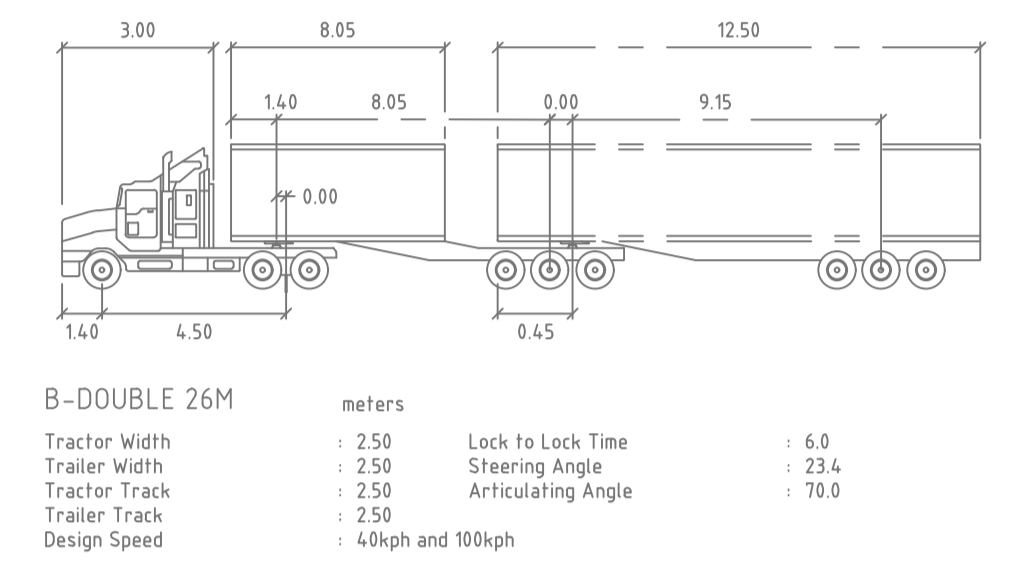
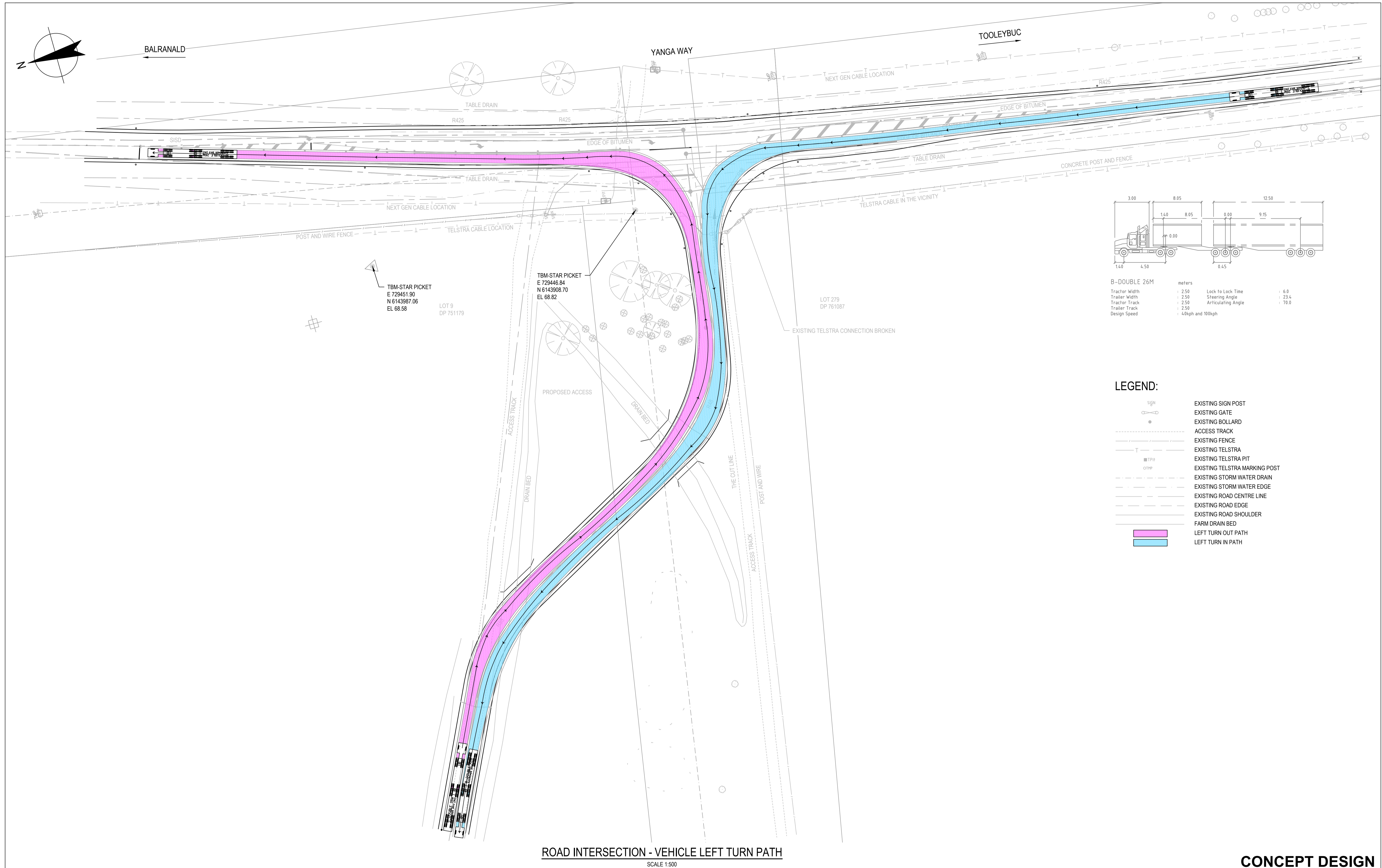

No	Revision	Note: * indicates signatures on original issue of drawing or last revision of drawing	Drawn	Job Manager	Project Director	Date
B	REISSUED TO CLIENT FOR REVIEW		AGV			
A	ISSUED TO CLIENT FOR REVIEW		EAS	PT*	JV*	29.01.18



**DO NOT SCALE**

GHD Pty Ltd  
Conditions of Use.  
This document may only be used by GHD's client (and any other person who GHD has agreed can use this document) for the purpose for which it was prepared and must not be used by any other person or for any other purpose.

Drawn	E. SANTOS	Designer	J. TIU
Drafting Check	M. MANLAPIT*	Design Check	G. DOUGHERTY*
Approved (Project Director)	J. VAESEN*		
Date	29.01.18		
Scale	1:500		

Client	<b>DECMIL GROUP LIMITED</b>		
Project	<b>SUNRAYSA ENTRANCE TRACK DESIGN</b>		
Title	<b>TRUCK VEHICLE TURN PATHS LEFT TURN PATH</b>		
Original Size	<b>A1</b>	Drawing No:	<b>61-35722-C002</b>
		Rev:	<b>B</b>



ROAD INTERSECTION - VEHICLE RIGHT TURN PATH  
SCALE 1:500

CONCEPT DESIGN

No	Revision	Note: * indicates signatures on original issue of drawing or last revision of drawing	Drawn	Job Manager	Project Director	Date
B	REISSUED TO CLIENT FOR REVIEW		AGV			
A	ISSUED TO CLIENT FOR REVIEW		EAS	PT*	JV*	29.01.18



**DO NOT SCALE**

GHD Pty Ltd  
Conditions of Use.  
This document may only be used by GHD's client (and any other person who GHD has agreed can use this document) for the purpose for which it was prepared and must not be used by any other person or for any other purpose.

Drawn	E. SANTOS	Designer	J. TIU
Drafting Check	M. MANLAPIT*	Design Check	G. DOUGHERTY*
Approved (Project Director)	J. VAESSEN*		
Date	29.01.18		
Scale	1:500		

Client	DECMIL GROUP LIMITED		
Project	SUNRAYSA ENTRANCE TRACK DESIGN		
Title	TRUCK VEHICLE TURN PATHS RIGHT TURN PATH		
Original Size	A1	Drawing No:	61-35722-C003
Rev:	B		

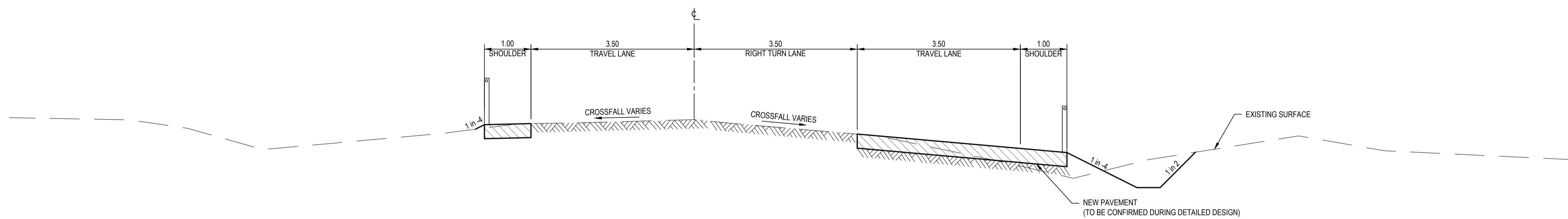

**A SECTION**  
C001 SCALE 1:50

**CONCEPT DESIGN**

No	Revision	Note: * indicates signatures on original issue of drawing or last revision of drawing	Drawn	Job Manager	Project Director	Date
B	REISSUED TO CLIENT FOR REVIEW		AGV			
A	ISSUED TO CLIENT FOR REVIEW		EAS	PT*	JV*	29.01.18

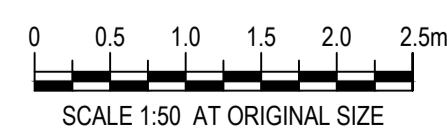

Level 10, 999 Hay Street Perth WA 6000  
PO Box Y3106 Perth WA 6832 Australia  
T 61 8 6222 8222 F 61 8 6222 8555  
E permail@ghd.com.au W www.ghd.com

<b>DO NOT SCALE</b>	Drawn	M. MANLAPIT	Designer	J. TIU	Client <b>DECMIL GROUP LIMITED</b> Project <b>SUNRAYSLIA ENTRANCE TRACK DESIGN</b> Title <b>TYPICAL SECTIONS</b>
	Drafting Check	M. MANLAPIT*	Design Check	G. DOUGHERTY*	
	Approved (Project Director)	J. VAESEN*	Date	29.01.18	
Scale	1:50	This Drawing must not be used for Construction unless signed as Approved		Original Size	<b>A1</b>
				Drawing No:	<b>61-35722-C004</b>
				Rev:	<b>B</b>