



**BLACKETT  
MAGUIRE+  
GOLDSMITH**

## **BCA ASSESSMENT REPORT**

**OAKDALE SOUTH ESTATE  
SITE 3B - TOYOTA  
MILNER AVENUE, HORSLEY PARK**

**PREPARED FOR:  
GOODMAN PROPERTY SERVICES (AUST) PTY LTD**

Revision 1

Date: 11.08.2016

**Project No.: 160174**

Address

Suite 2.01,  
22-36 Mountain St  
Ultimo NSW 2007

Contact

Ph: 02 9211 7777  
Fax: 02 9211 7774



## CONTENTS

<b>A.</b>	<b>INTRODUCTION</b>	<b>3</b>
<b>A.1</b>	<b>BACKGROUND / PROPOSAL</b>	<b>3</b>
<b>A.2</b>	<b>AIM</b>	<b>3</b>
<b>A.3</b>	<b>PROJECT TEAM</b>	<b>4</b>
<b>A.4</b>	<b>DOCUMENTATION</b>	<b>4</b>
<b>A.5</b>	<b>REGULATORY FRAMEWORK</b>	<b>4</b>
<b>A.6</b>	<b>LIMITATIONS &amp; EXCLUSIONS</b>	<b>4</b>
<b>A.7</b>	<b>TERMINOLOGY</b>	<b>5</b>
<b>B.</b>	<b>BUILDING CHARACTERISTICS</b>	<b>6</b>
<b>B.1</b>	<b>BUILDING CLASSIFICATION</b>	<b>6</b>
<b>C.</b>	<b>SUMMARY OF KEY COMPLIANCE ISSUES</b>	<b>7</b>
<b>C.1</b>	<b>MATTERS REQUIRING FURTHER RESOLUTION/PLAN AMENDMENTS</b>	<b>7</b>
<b>C.2</b>	<b>MATTERS REQUIRING FIRE SAFETY ENGINEERED ALTERNATIVE SOLUTIONS</b>	<b>7</b>
<b>D.</b>	<b>BCA ASSESSMENT</b>	<b>7</b>
<b>D.1</b>	<b>BCA DEEMED-TO-SATISFY COMPLIANCE ISSUES:</b>	<b>7</b>
	SECTION C – FIRE RESISTANCE	8
	SECTION D – ACCESS & EGRESS	11
	SECTION E – SERVICES AND EQUIPMENT	20
	SECTION F – HEALTH & AMENITY	22
	SECTION J – ENERGY EFFICIENCY	22
<b>E.</b>	<b>CONCLUSION</b>	<b>24</b>

REPORT STATUS				
DATE	REVISION	STATUS	AUTHOR	REVIEWED
24.05.2016	0	Preliminary Assessment	DG	TH
11.08.2016	1	Updated Assessment – DA Plans	DG	TH

Prepared by:

Dean Goldsmith  
**Director**  
**Blackett Maguire + Goldsmith**



## A. INTRODUCTION

### A.1 BACKGROUND / PROPOSAL

Blackett Maguire + Goldsmith Pty Ltd (BM+G) have been commissioned by Goodman Property Services (Aust) Pty Ltd, to undertake a preliminary review of the proposed development against the deemed-to-satisfy (DTS) provisions of the Building Code of Australia 2016 (BCA) pursuant to the provisions of clause 145 of the *Environmental Planning & Assessment Regulation 2000* and clause 18 of the *Building Professionals Regulation 2007*.

The proposed industrial facility includes a 36,100m<sup>2</sup> Warehouse, an 8,000m<sup>2</sup> Warehouse Mezzanine, an 1,478m<sup>2</sup> 2 storey ancillary Office, with associated Dock Office, external awnings, carparking and hardstand areas for use by Toyota to store parts and accessories.

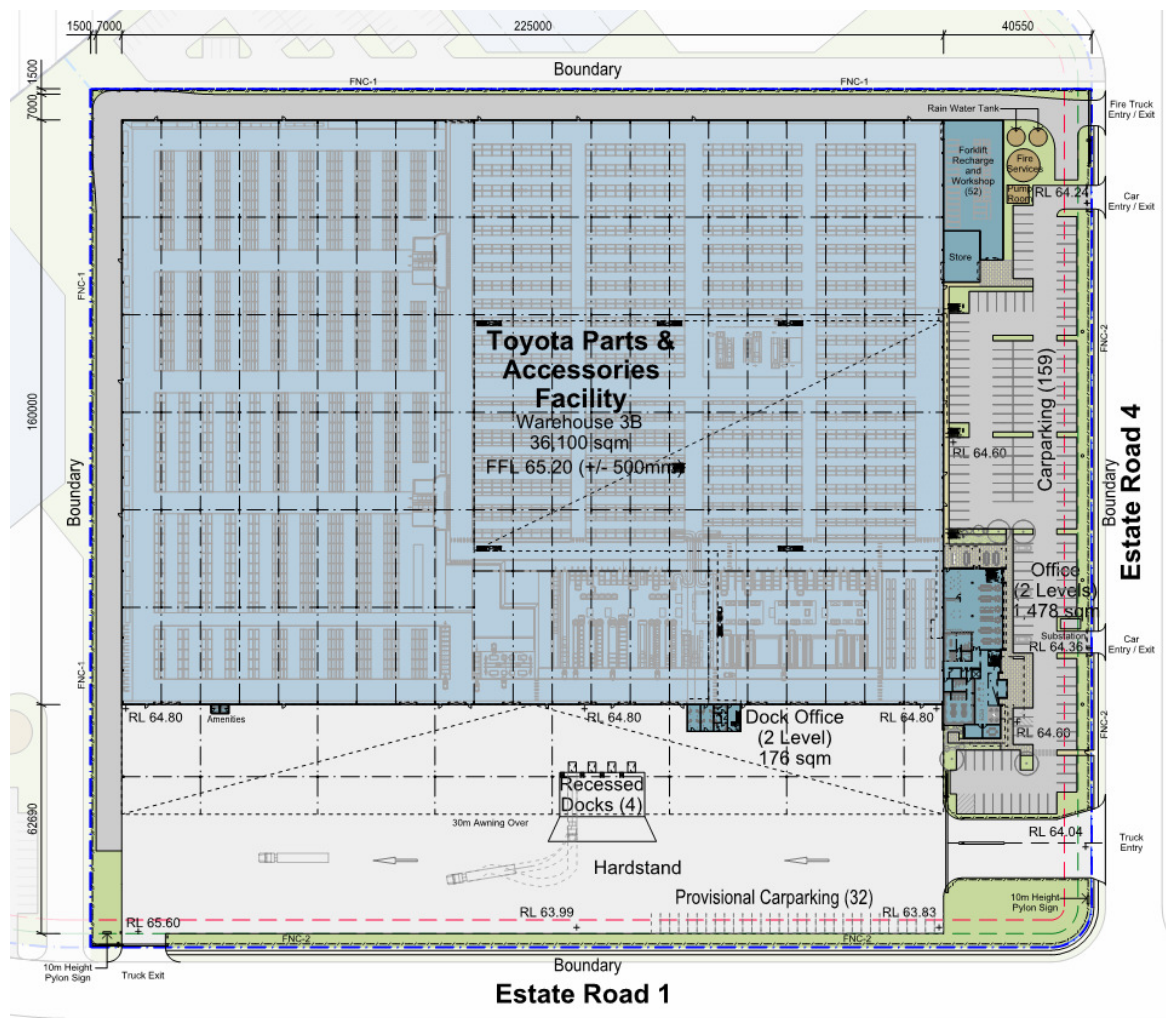

Source: SBA Architectural Plan DA01 Rev.H

### A.2 Aim

The aim of this report is to:

- Confirm that the referenced documentation has been reviewed by an appropriately qualified Building Surveyor.
- Undertake an assessment of the proposed new building works against the deemed-to-satisfy provisions of the BCA.
- Identify matters that require plan amendments in order to achieve compliance with the BCA.
- Identify matters that are to be required to be addressed by Alternative Solutions.



- Identify essential fire safety measures applicable to the building.
- Accompany the Development Application for consideration and approval by the Consent Authority, and to enable the Consent Authority to be satisfied that the development can readily achieve compliance with the BCA.

### A.3 PROJECT TEAM

The following BM+G Team Members have contributed to this Report:

- Assessment – Dean Goldsmith (Director)
- Peer Review – Tony Heaslip (Director)

### A.4 DOCUMENTATION

The following documentation has been reviewed, referenced and/or relied upon in the preparation of this report:

- BCA 2016
- Guide to the BCA 2016
- Environmental Planning and Assessment Act 1979 (EP&A)
- Environmental Planning and Assessment Regulation 2000 (EP&AR).
- Access to Building Premises Building Standards 2010.
- Architectural plans prepared by SBA Architects:

Drawing No.	Rev	Date	Drawing No.	Revision	Date
DA00	D	05.08.2016	DA06	H	05.08.2016
DA01	H	05.08.2016	DA07	D	05.08.2016
DA02	J	05.08.2016	DA08	C	05.08.2016
DA03	H	05.08.2016	DA09	B	05.08.2016
DA04	G	05.08.2016	DA10	C	05.08.2016
DA05	H	05.08.2016			

### A.5 REGULATORY FRAMEWORK

Pursuant to clause 145 of the Environmental Planning and Assessment (EPA) Regulation 2000 all new building work must comply with the relevant requirements of the BCA as in force at the time the application for the Construction Certificate is made. In this regard it is noted that the Construction Certificate application will be made after 1st May 2015, as such BCA 2015 Version applies to the subject development.

Clause 143(3) of the EPA Regulation 2000 prevents a certifying authority from issuing a construction certificate if the proposed new work will result in a reduction to the fire protection and structural capacity of the building.

### A.6 LIMITATIONS & EXCLUSIONS

The limitations and exclusions of this report are as follows:

- The following assessment is based upon a review of the architectural documentation.
- No assessment has been undertaken with respect to the Disability Discrimination Act (DDA) 1992. The building owner should be satisfied that their obligations under the DDA have been addressed. In this regard however, the provisions of the DDA Access to Premises – Buildings Standards have been considered as they are generally consistent with the accessibility provisions of the BCA as referenced below.
- The Report does not address matters in relation to the following:
  - i. Local Government Act and Regulations.
  - ii. NSW Public Health Act 1991 and Regulations.
  - iii. Occupational Health and Safety (OH&S) Act and Regulations.
  - iv. Work Cover Authority requirements.



- v. Water, drainage, gas, telecommunications and electricity supply authority requirements.
- vi. DDA 1992.
- BM+G Pty Ltd do not guarantee acceptance of this report by Local Council, FRNSW or other approval authorities.
- No part of this document may be reproduced in any form or by any means without written permission from BM+G Pty Ltd. This report is based solely on client instructions, and therefore, should not be used by any third party without prior knowledge of such instructions.

## **A.7 TERMINOLOGY**

### *Alternative Solution*

A Building Solution which complies with the Performance Requirements other than by reason of satisfying the DtS Provisions.

### *Building Code of Australia (BCA)*

Document published on behalf of the Australian Building Codes Board. The BCA is a uniform set of technical provisions for the design and construction of buildings and other structures throughout Australia and is adopted in New South Wales (NSW) under the provisions of the EPA Act and Regulation. Building regulatory legislation stipulates that compliance with the BCA Performance Requirements must be attained and hence this reveals BCA's performance based format.

### *Construction Certificate*

Building Approval issued by the Certifying Authority pursuant to Part 4A of the EP&A Act 1979.

### *Construction Type*

The construction type is a measure of a buildings ability to resist a fire. The minimum type of fire-resisting construction of a building must be that specified in Table C1.1 and Specification C1.1, except as allowed for—

- (i) certain Class 2, 3 or 9c buildings in C1.5; and
- (ii) a Class 4 part of a building located on the top storey in C1.3(b); and
- (iii) open spectator stands and indoor sports stadiums in C1.7.

Note: Type A construction is the most fire-resistant and Type C the least fire-resistant of the types of construction.

### *Climatic Zone*

Is an area defined in BCA Figure A1.1 and in Table A1.1 for specific locations, having energy efficiency provisions based on a range of similar climatic characteristics.

### *Deemed to Satisfy Provisions (DtS)*

Provisions which are deemed to satisfy the Performance Requirements.

### *Effective Height*

The vertical distance between the floor of the lowest storey included in the calculation of rise in storeys and the floor of the topmost storey (excluding the topmost storey if it contains only heating, ventilating, lift or other equipment, water tanks or similar service units).

### *Fire Resistance Level (FRL)*

The grading periods in minutes for the following criteria-

- (a) structural adequacy; and
- (b) integrity; and
- (c) insulation,

and expressed in that order.



#### *Fire Source Feature (FSF)*

The far boundary of a road which adjoins the allotment; or a side or rear boundary of the allotment; or an external wall of another building on the allotment which is not a Class 10 building.

#### *National Construction Code Series (NCC)*

The NCC was introduced 01 May 2011 by the Council of Australian Governments. The BCA Volume One (Class 2 to 9 Buildings) is now referenced as the National Construction Code Series Volume One — BCA.

#### *Occupation Certificate*

Building Occupation Approval issued by the Principal Certifying Authority pursuant to Part 4A of the EPA Act 1979.

#### *Open Space*

A space on the allotment, or a roof or other part of the building suitably protected from fire, open to the sky and connected directly with a public road.

#### *Performance Requirements of the BCA*

A Building Solution will comply with the BCA if it satisfies the Performance Requirements. A Performance requirement states the level of performance that a Building Solution must meet.

Compliance with the Performance Requirements can only be achieved by-

- (a) complying with the DtS Provisions; or
- (b) formulating an Alternative Solution which-
  - (i) complies with the Performance Requirements; or
  - (ii) is shown to be at least equivalent to the DtS Provisions; or
- (c) a combination of (a) and (b).

## **B. BUILDING CHARACTERISTICS**

### **B.1 BUILDING CLASSIFICATION**

In summary, the key building characteristics have been identified as follows:

▪ <b>BCA Classification:</b>	Class 5 (Offices) & Class 7b (Warehouse)
▪ <b>Rise in Storeys:</b>	Two (2)
▪ <b>Effective Height:</b>	Less than 12m
▪ <b>Type of Construction:</b>	Type C Construction (Large Isolated Building)
▪ <b>Climate Zone:</b>	Zone 6
▪ <b>Max. Floor Area &amp; Volume:</b>	46,456m <sup>2</sup> and Greater than 108,000m <sup>3</sup> (Large Isolated Building)



## C. SUMMARY OF KEY COMPLIANCE ISSUES

The following comprises a summary of the key compliance issues identified under the clause-by-clause assessment in Appendix 1 of this report. These matters are to be addressed prior to issue of the Construction Certificate.

### C.1 MATTERS REQUIRING FURTHER RESOLUTION/PLAN AMENDMENTS

BCA Clause/s		Description
1.	D3 & AS 1428.1-2009	Access to the building is required from the following: + All main entry points on the allotment boundary; and + Any accessible car parking within the site.  The reference plans indicate that compliance with the above is readily achievable in this instance, however further details are required with respect to levels from the site entry to the main entry of the building.
2.	Section J	A separate report will be required from an Energy Efficiency consultant to outline the applicable requirements for the building.

### C.2 MATTERS REQUIRING FIRE SAFETY ENGINEERED ALTERNATIVE SOLUTIONS

BCA Clause/s		Description
1.	C2.4	The following compliance issues have been identified with respect to the proposed perimeter vehicular access serving Site 1C: + The vehicle access northern side and NE corner of the building is greater than 18m from the building via Estate Rd No.4 and the hardstand access driveway (up to 53m).
2.	D1.4 /D1.5	The current plans indicate that exit travel distances, and distances between alternative exits within the warehouse and on the warehouse mezzanine will not comply with D1.4 & D1.5 – respectively – see further details below.
3.	D1.9	The discharge of the exit stairs from the warehouse mezzanine exceed 40m to an exit on ground floor and the total exit travel distance via the exit stairs on the mezzanine level exceeds 80m – see further details below.
4.	E1.3 (inter alia AS 2419.1: 2005)	To allow external fire hydrants to be located beneath the awnings protruding from the northern elevations and the hydrant booster to be positioned so that it is not within sight of the main office entry.
5.	E2.2	It is noted that a rationalised automatic smoke exhaust system throughout the building is currently proposed.

## D. BCA ASSESSMENT

### D.1 BCA DEEMED-TO-SATISFY COMPLIANCE ISSUES:

The following comments have been made in relation to the relevant BCA provisions relating to the compliance issues associated with the proposed warehouse development.

#### 1. Part B1 – Structural Provisions

Structural engineering details prepared by an appropriately qualified structural engineer to be provided to demonstrate compliance with Part B1.

*Comments: Structural design and certification will be required at CC application stage.*



## 2. Clause B1.4 – Materials and Forms of Construction

Structural resistance of materials and forms of construction to comply with BCA clause B1.4. Design certification confirming compliance in this instance is to also be submitted with the Construction Certificate application.

This will include the following Australian Standards (where relevant):

1. AS 1170.0 – 2002 General Principles
2. AS 1170.1 – 2002, including certification for balustrades (dead and live loads)
3. AS 1170.2 – 2002, Wind loads
4. AS 1170.4 – 2007, Earthquake loads
5. AS 3700 – 2001, Masonry code
6. AS 3600 – 2009, Concrete code
7. AS 4100 – 1998, Steel Structures and/or
8. AS 4600 – 2005, Cold formed steel.
9. AS 1720.1 – 2010, Design of timber structures
10. AS 2047 – 1999, Windows in buildings.
11. AS 1288 – 2006, Glass in buildings.
12. AS 3660.1 – 2000, Termite control.
13. AS 1860 – 2006, Particle board flooring

*Comments: Structural design and certification will be required at CC application stage.*

## **SECTION C – FIRE RESISTANCE**

### **FIRE RESISTANCE AND STABILITY**

#### **3. Clause C1.1 – Type of Construction Required**

The minimum type of fire-resisting construction of a building must be that specified in Table C1.1 and Specification C1.1 except as allowed for in this clause.

*Comments: As the building is situated on one allotment, and the building will be located more than 3m from a fire source feature, fire resisting construction under Specification C1.1 is not required.*

#### **4. Clause C1.10 – Fire Hazard Properties**

The fire hazard properties of the following linings, materials and assemblies in a Class 2 to 9 building must comply with **Specification C1.10** and the additional requirements of the **NSW Provisions** of the Code.

*Comments: Certification of design will be required at CC Application stage and test certificates of the proposed linings will be required to be submitted prior to issue of the Occupation Certificate.*

#### **5. Clause C1.11 – Performance of external walls**

Concrete external walls are required to be designed to minimize the likelihood of collapsing outwards in the event of a fire.

*Comments: Design certification will be required to be submitted by a Structural Engineer confirming compliance with Specification C1.11 at the CC Application stage.*

## **COMPARTMENTATION AND SEPARATION**

#### **6. Clause C2.2 – General Floor Area and Volume Limitations**

Sets out the parameters for the area and volume of Class 5, 6, 7, 8 & 9 buildings as required by sub-clauses (a), (b) & (c).

*Comments: The proposed floor area and volume of each building exceeds the limitations for Type C Construction, and as such the facility is defined as a single “Large Isolated Building” - see comments under C2.3 and C2.4 below.*

#### **7. Clause C2.3 – Large Isolated Buildings**

A Large Isolated Building that exceeds 18 000 m<sup>2</sup> in floor area or 108 000 m<sup>3</sup> in volume, is required to be—



- (i) protected throughout with a sprinkler system complying with Specification E1.5; and
- (ii) provided with a perimeter vehicular access complying with C2.4(b).

*Comments: The floor area/volume limitations under C2.2 can be exceeded where the building is deemed to be a 'Large Isolated Building'. This will allow each building to remain as Type C Construction. As the compartment size exceeds 18,000m<sup>2</sup> and 108,000m<sup>3</sup> and the ceiling height is more than 12m, the provision of sprinklers, smoke exhaust and perimeter vehicular access are required. Note: The perimeter vehicular access requirements are outlined below under C2.4.*

## 8. Clause C2.4 - Requirements for Open Spaces & Vehicular Access

A minimum unobstructed width of 6m is required around the building for fire brigades perimeter vehicular access with no part of its furthest boundary more than 18m from the building. Furthermore, vehicular access must have a load bearing capacity and unobstructed height to permit the operation and passage of fire brigade vehicles, and must provide reasonable pedestrian access from the vehicular access to the building.

*Comments: It will be necessary for an alternative solution to be prepared to address these non-compliance issues below, in order to demonstrate compliance with Performance Requirement CP9. The departures from this clause are as follows:*

- + The vehicle access on the Northern side and the NE corner of the building is greater than 18m from the building (up to 53m) as circled below.

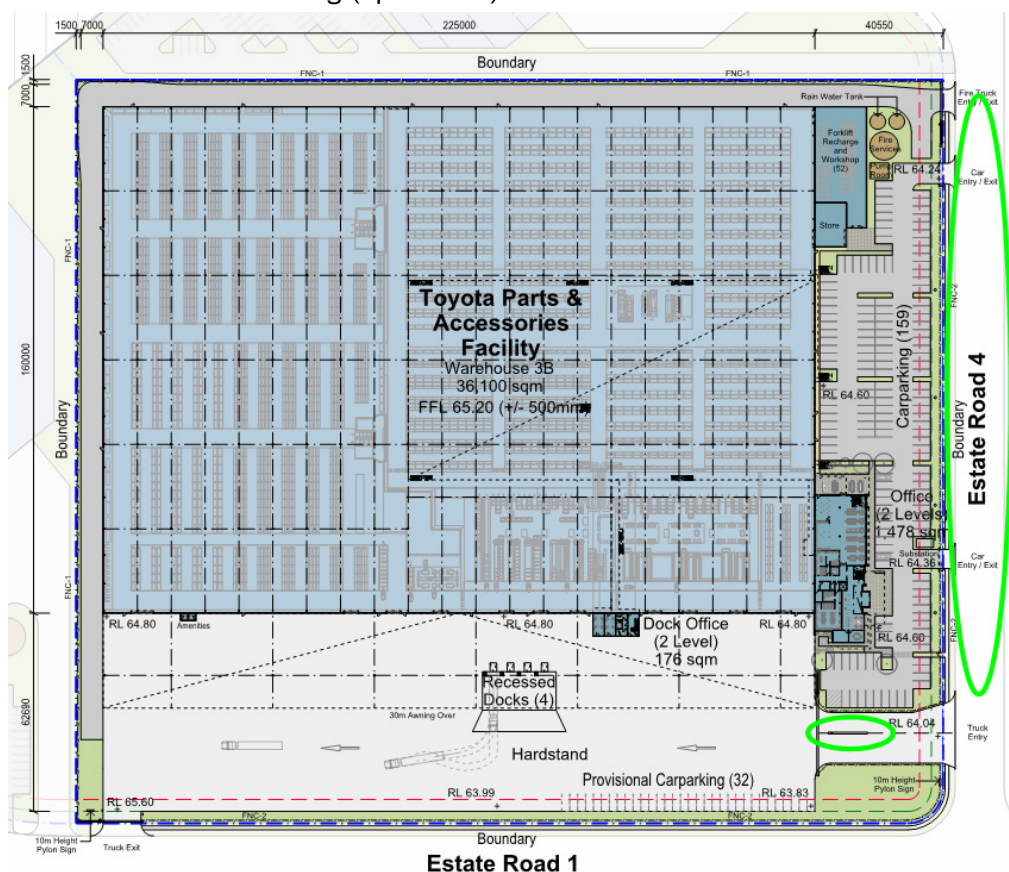

## 9. Clause C2.12 - Separation of Equipment

Equipment other than that described in (b) and (c) must be separated from the remainder of the building with construction complying with (d), if that equipment comprises –

- (i) Lift motors and lift control panels; or
- (ii) Emergency generators used to sustain emergency equipment operating in the emergency mode; or



- (iii) Central smoke control plant; or
- (iv) Boilers; or
- (v) A battery or batteries installed in the building that have a voltage exceeding 24 volts and a capacity exceeding 10 ampere hours.

**\* Note: If the designated enclosure for forklift charging includes removal and storage of batteries the enclosure may require 2hr fire separation.**

Equipment need not be separated in accordance with (a) if the equipment comprises -

- (i) smoke control exhaust fans located in the air stream which are constructed for high temperature operation in accordance with Specification E2.2b; or
- (ii) stair pressurising equipment installed in compliance with the relevant provisions of AS/NZS 1668.1; or
- (iii) a lift installation without a machine-room; or
- (iv) equipment otherwise adequately separated from the remainder of the building.

Separation of on-site fire pumps must comply with the requirements of AS 2419.1.

Separating construction must have

- (i) except as provided by (ii)—
  - (A) an FRL as required by Specification C1.1, but not less than 120/120/120; and
  - (B) any doorway protected with a self-closing fire door having an FRL of not less than -/120/30; or
- (ii) when separating a lift shaft and lift motor room, an FRL not less than 120/-/-.

Comments: Architect to note.

## **10. Clause C2.13 - Electricity Supply System**

- (a) An electricity substation, main switchboard which sustains emergency equipment operating in the emergency mode, located within a building must –
  - (i) Be separated from any other part of the building by construction having an FRL of not less than 120/120/120; and
  - (ii) Having any doorway in that construction protected with a self-closing fire door having an FRL of not less than -/120/30
  - (iii) Be separated from any other part of the building by construction having an FRL of not less than -/120/30.
  - (iv) Have any doorway in that construction protected with a self-closing fire door having an FRL of not less than -/120/30.
- (b) A main switchboard located within the building which sustains emergency equipment operating in the emergency mode must –
  - (i) be separated from any other part of the building by construction having an FRL of not less than 120/120/120; and
  - (ii) have any doorway in that construction protected with a self-closing fire door having an FRL of not less than -/120/30.
- (c) Electrical conductors located within a building that supply –
  - (i) a substation located within the building which supplies a main switchboard covered by (b); or
  - (ii) a main switchboard covered by (b), must—
  - (iii) have a classification in accordance with AS/NZS 3013 of not less than—
    - A. if located in a position that could be subject to damage by motor vehicles — WS53W; or
    - B. otherwise — WS52W; or
  - (i) be enclosed or otherwise protected by construction having an FRL of not less than 120/120/120.

**Note:** Where emergency equipment is required in a building, all switchboards in the electrical installation, which sustain the electricity supply to the emergency equipment switchgear is separated from the non-emergency equipment



switchgear by metal partitions designed to minimise the spread of fault from the non-emergency equipment switchgear.

*Comments:* Architect & electrical consultant to note.

## **SECTION D - ACCESS & EGRESS**

### **PROVISION FOR ESCAPE.**

#### **11. Clause D1.4 - Exit Travel Distances**

This clause specifies the permitted travel distances allowable from Class 2 to Class 9 buildings.

*Comments:* The proposed building does not comply with the 40m exit travel distance requirement under this clause, as follows:

- + Warehouse (Ground Floor under Mezzanine) – Maximum travel distance of 109m to the nearest exit.
- + Warehouse (Mezzanine) and Offices – Travel distance are less than 48m.

#### **12. Clause D1.5 - Distances Between Alternative Exits**

Exits required as alternative exits must be –

- (a) not less than 9m apart; and
- (b) not more than – 60m apart.
- (c) Located so that the alternative paths of travel do not converge such that they become less than 6m apart.

*Comments:* The proposed building also does not comply with the DTS maximum 60m distance required between alternative exits under this clause. The maximum distance between alternative exits were measured as follows:

- + Warehouse (Ground Floor) – Maximum travel distance of 195m between alternative exits.
- + Warehouse (Mezzanine) – Maximum travel distance of 84m between alternative exits.

*Note 1:* The above max. distances between alternative exits takes into consideration the racking layout shown on the referenced plans.

*Note 2:* It is understood that a Fire Safety Engineer is to be engaged to prepare an Alternative Solution having regard to the above non-compliance. In this regard the relevant Performance Requirements are DP4 and EP2.2.

#### **13. Clause D1.6 - Dimensions of Exits**

This clause details the minimum dimensions such as height and width of paths of travel from Class 2 to 9 buildings. It also specifies the minimum dimensions of doorways from the various compartments and the width of exit doors from buildings depending on the uses and functions carried out within them.

*Comments:* Population numbers for the proposed warehouse buildings have been provided by Toyota/Goodman – as listed under D1.13 below. Based upon these maximum population numbers compliance with D1.6 is achieved in the current design.

In addition to the above, it is to be noted that all exit paths are required to have a minimum clear height of 2m and 1980mm through doorway openings per D1.6(a).

#### **14. Clause D1.9 - Travel by non-fire isolated stairways and ramps**

Sub-clauses (a) to (f) set out the prescribed travel distances to be provided in required exits of Class 2 to 9 buildings and Class 4 parts of buildings. The sub-clauses set out the maximum distances to be taken into account for the various uses in each Class of building.

*Comments:* Travel via non-fire isolated exits complies with BCA clause D1.9 in the office, however, the exit stairs serving the warehouse mezzanine include the following non-compliances:



- + The central exit stairs off the warehouse mezzanine discharge at a point that is greater than 40m from the nearest exit to open space – worst case is approx. 78m.
- + The total exit distance off the warehouse mezzanine via the non-fire isolated exit stairs exceeds 80m – worst case is approx. 125m.

#### **15. Clause D1.10 – Discharge From Exits**

Where an exit discharges to open space that is at a different level to that of the public roadway, the path of travel must be via a 1:8 ramp or DTS compliant stairs.

*Comments:* We note that compliance is readily achievable in this instance.

#### **16. Clause D1.13 – Number of Persons Accommodated**

Clause D1.13 and Table D1.13 are used to calculate the anticipated number of people in particular types of buildings so that minimum exit widths and the required number of sanitary and other facilities can be calculated. This clause and table are not to be used for non-BCA purposes.

*Comments:* Population numbers for the proposed warehouse buildings have been provided by Toyota/Goodman – as listed below (with a maximum peak population at shift change over of 138 persons):

- + Main Office – 8 persons
- + Warehouse – 56 persons
- + Dock Office – 16 persons

### **CONSTRUCTION OF EXITS**

#### **17. Clause D2.3 – Non-fire-isolated Stairways & Ramps**

This clause requires that required non-fire-isolated stairways and ramps must be either constructed in accordance with D2.2 or the alternative options set out in D2.3 (a) to (c).

*Comments:* The requirements of D2.3 apply to the proposed stairs serving the office upper levels (main office & dock office) and the stairs serving the warehouse mezzanine.

#### **18. Clause D2.7 – Installations in Exits & Paths of Travel**

This clause restricts the installation of certain services in fire-isolated exits, non-fire-isolated exits and certain paths of travel to exits.

Any electrical meters, distribution boards or ducts, central communications distribution boards or equipment or electrical motors must be smoke sealed and enclosed within non-combustible construction with any penetrations smoke sealed.

Gas and other fuel services must not be located within a required exit.

Note: An opening to any chute that or duct that is to convey hot products or combustion from a boiler incinerator, fireplace or the like must not be located in any part of a required exit or any corridor, hallway, lobby or the like leading to a required exit.

*Comments:* Architect to note.

#### **19. Clause D2.8 – Enclosures under Stairs and Ramps:**

The space below a required non fire-isolated stairway (including an external stairway) or non-fire-isolated ramp must not be enclosed to form a cupboard or other enclosed space unless-

- (i) the enclosing walls and ceilings have an FRL of not less than 60/60/60; and
- (ii) any access doorway to the enclosed space is fitted with a self-closing -/60/30 fire door.

*Comments:* Architect to note.

#### **20. Clause D2.9 – Width of Stairs**

The required width of a stairway must be measured clear of all obstructions such as handrails, projecting parts of balustrades or other barriers and the like; and extend without interruption, except for ceiling cornices, to a height not less than 2m vertically



above a line along the nosings of the treads or the floor of the landing. A required stairway that exceeds 2m in width is counted as having a width of only 2m unless it is divided by a handrail, balustrade or other barrier continuous between landings and each division is less than 2m wide.

*Comments:* Compliance readily achievable, 1m clear width between handrails is required.

## 21. Clause D2.13 – Goings & Risers

This clause sets out the detailed requirements for the construction and geometry of the goings and risers in required stairways.

*Comments:* The stairs must comply with the following requirements of BCA clause D2.13.

- + not more than 18 nor less than 2 risers in each flight.
- + except as permitted by (i), going (G), riser (R) and quantity (2R + G) in accordance with Table D2.13.
- + except as permitted by (i), goings and risers that are constant throughout in one flight.
- + risers which do not have any openings that would allow a 125mm sphere to pass through between the treads.
- + treads which have a non-slip finish or an adequate non-skid strip near the edge of the nosings.
- + not more than 36 risers in consecutive flights without a change in direction of at least 30°.
- + In the case of a required stairway, no winders in lieu of a landing.

Table D2.13 RISER AND GOING DIMENSIONS (mm)

	Riser (R)		Going (G) <sup>(2)</sup>		Quantity (2R+G)	
	Max	Min	Max	Min	Max	Min
Public stairways	190	115	355	250	700	550
Private stairways <sup>(1)</sup>	190	115	355	240	700	550

125 mm sphere must not pass through treads

Notes:

- Private stairways are—
  - stairways in a *sole-occupancy unit* in a Class 2 building or Class 4 part of a building; and
  - in any building, stairways which are not part of a *required exit* and to which the public do not normally have access.
- The going in tapered treads (except winders in lieu of a quarter or half landing) in a curved or spiral stairway is measured—
  - 270 mm in from the outer side of the unobstructed width of the stairway if the stairway is less than 1 m wide (applicable to a non-*required* stairway only); and
  - 270 mm from each side of the unobstructed width of the stairway if the stairway is 1 m wide or more.

## 22. Clause D2.14 – Landings

The dimensions and gradients of landings in stairways are set out in this clause; the configuration will depend on the proposed use of a building. Landing surfaces must be slip resistant surfaces OR slip resistant nosing not less than that listed in Table D2.14 when tested in accordance with AS4586.

Table D2.14 SLIP-RESISTANCE CLASSIFICATION

Application	Surface conditions	
	Dry	Wet
Ramp steeper than 1:14	P4 or R11	P5 or R12
Ramp steeper than 1:20 but not steeper than 1:14	P3 or R10	P4 or R11
Tread or landing surface	P3 or R10	P4 or R11
Nosing or landing edge strip	P3	P4



*Comments: Details to be confirmed with the occupation certificate documentation.*

### 23. Clause D2.15 – Thresholds

The threshold of a doorway must not incorporate a step or ramp at any point closer to the doorway than the width of the door leaf unless –

- (i) the doorway opens to a road or open space, external stair landing or external balcony; and
- (ii) the door sill is not more than 190mm above the finished surface of the ground, balcony, or the like, to which the doorway opens.
- (iii) unless the door is provided with a threshold ramp or step ramp in accordance with AS 1428.1

*Comments: Architect to note.*

### 24. Clause D2.16 – Balustrades or Other Barriers

This clause details where balustrades are required to be provided and sets out in specific detail the construction requirements. Typically the following will apply to this class of building:

- + Balustrades are required where the fall to the level below is more than 1m in height. The minimum height of a balustrade is 1m above the floor of the landing, walkway or the like; and 865mm above the floor of a stairway or a ramp.
- + For a fall of more than 4m to the surface level below, a window sill must be a minimum of 865mm in height above the height of the floor surface.
- + Where the floor is more than 4m above the surface beneath the balustrade any horizontal or near horizontal members between 150mm and 760mm above the floor must not could facilitate climbing.
- + Balustrades must be constructed so as to not permit a sphere of 125mm diameter to pass through. The exception to this is within fire isolated exits within the building, or within a class 7b or 8 building, where the rails can be positioned a maximum of 460mm apart, so long as a bottom rail is located so a sphere of 150mm cannot pass through the opening between the nosing of the stair treads and the rail or between the floor of the landing, balcony or the like.

*Comments: Details of the proposed balustrades are to be provided with the application for the construction certificate for assessment detailing compliance with the above requirements.*

### 25. Clause D2.17 – Handrails

This Clause sets out the requirements regarding the location, spacing and extent of handrails required to be installed in buildings.

*Comments: Handrails are required to both sides of all stairways and are to comply with AS 1428.1-2009 (refer to figures below):*

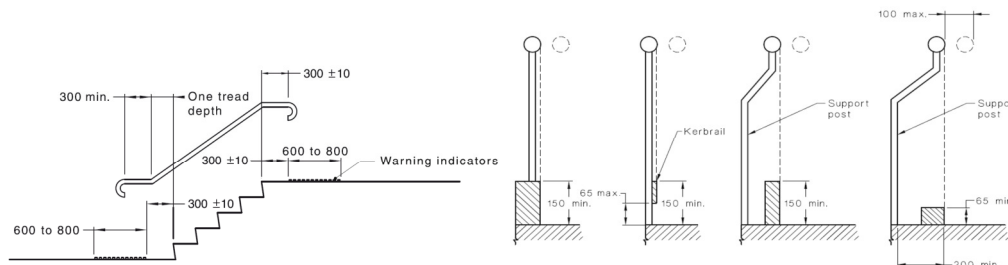

Source – Section 10.3 of AS1428.1-2009

### 26. Clause D2.19 – Doorways and Doors

This clause applies to all doorways and refers to the types of doors that cannot be used in buildings of prescribed uses, the use of power operated doors and the force required to operate sliding doors.



If the door is also power operated, it must be opened manually under a force of not more than 110N if there is a malfunction or failure to the power source; or upon the activation of a fire or smoke alarm anywhere in the fire compartment served by the door.

*Comments:* Architect to note – this requirement applies to the auto-sliding doors that form the main entry/exit to the ground floor of the office.

#### **27. Clause D2.20 – Swinging Doors**

A swinging door in a required exit or forming part of a required exit must be installed to the requirements of sub-clauses (a), (b) & (c).

All doorways are required to achieve a minimum unobstructed clear width of 850mm (clear opening width does not include the door leaf thickness). The following excerpt from AS1428.1-2009 identifies how clear opening width is measured for swinging and sliding doors:

Note: Generally, a proposed 920 doorway will achieve this 850mm minimum requirement.

*Comments:* The exit doors from the ground floor dock office must swing outwards in the direction of egress or be fitted with a manual hold open device.

#### **28. Clause D2.21 – Operation of Latch**

A door in a required exit or forming part of a required exit and in a path of travel to a required exit must be readily openable without a key from the side that faces a person seeking egress, by a single downward action or pushing action on a single device which is located between 900mm & 1.1m from the floor. This clause prohibits the use of devices such as deadlocks and knobs where knobs must be operated in a twisting motion in accordance with sub-clauses (a) & (b). D2.21 also sets out exceptions in relation to buildings where special security arrangements are required in relation to the uses carried out.

*Comments:* Architect to note.

### **ACCESS FOR PEOPLE WITH A DISABILITY (incl. DDA ACCESS TO PREMISES STANDARD)**

#### **29. Clause D3.2 – Access to Buildings**

This part requires accessways to be provided to accessible buildings from the main points of pedestrian entry at the allotment boundary and any accessible car parking space or accessible associated buildings connected by a pedestrian link.

*Comments:* Compliant Access is required throughout all areas in the proposed building in accordance with AS 1428.1-2009. Refer to D3.3 and D3.4 below.

#### **30. Clause D3.3 – Parts of the Building to be Accessible**

This part specifies the requirements for accessways within buildings which must be accessible.

Note: If compliant access is not proposed to be provided to the Warehouse areas in each building, comment will be required from an Access Consultant as to whether a concession under D3.4 or an alternative solution can be considered.

*Comments:* The following provisions of Clause D3.3 and in turn AS 1428.1-2009 are applicable to the proposed buildings:

- + Access into the principal entrance of the ground floor main lobby of the warehouse will be required to comply with AS1428.1-2009. This will necessitate 1:40 cross falls / landings at the accessible entrance.
- + An accessible pathway is required to be provided from the Estate Road adjoining the site to the main entry of the warehouse. Details demonstrating compliance will be required at CC Application and particular attention is drawn to the need to provide dedicated pathways that are independent of the truck accessway around the site.
- + A passenger lift is required in the Main Office as the floor area exceeds 200m<sup>2</sup> and the lift is required to comply with BCA Clause E3.6 in order to access the upper storey. The lift floor dimensions must be a minimum of 1.1m wide x 1.4m deep for all



lifts that travel less than 12m. Design details are also required on the Construction Certificate plans. Note: Refer to comments under D3.4 in relation to accessibility to the warehouse mezzanine structure (which also exceeds 200m<sup>2</sup>)

- + Turning Spaces & Passing Spaces for people in wheelchairs are required to be provided in common corridors in accordance with Section 6 of AS 1428.1-2009.
- + All new internal surfaces are required to have a slip-resistant surface and the texture of the surface shall be traversable by persons with a disability pursuant to Section 7.1 of AS1428.1-2009:
  - i. Internal finishes and coverings (i.e. vinyl and tiles) are required to achieve a slip resistance classification under wet & dry conditions to comply with AS/NZS 4586-2004 'Slip Resistance Classification of New Pedestrian Surface Materials'.
  - ii. All finished vertically abutting floor surfaces are to be trip free, the following details demonstrate the tolerance level for floor finishes:



Figure 6: Trip Free Surfaces

Source – Section 7.2 of AS1428.1-2009

- + Each accessible stairway are required to be designed and constructed in accordance with the requirements specified under Section 10 and 11 of AS1428.1-2009 that includes handrails on either side:

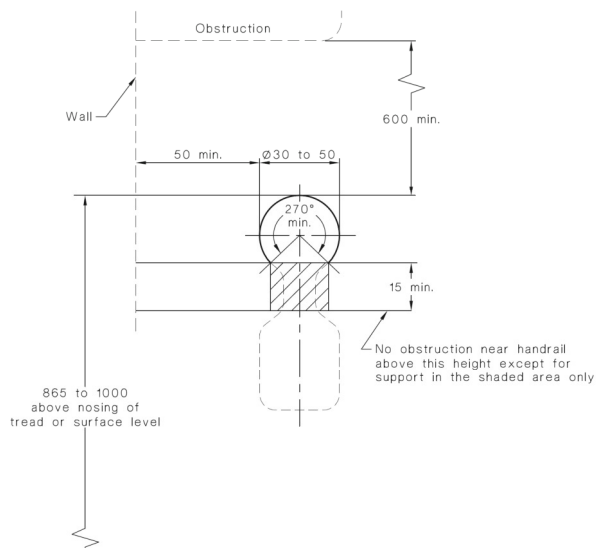

Figure 7: Handrail Details

Source – Section 10.3 and 12 of AS1428.1-2009





- + A luminance contrast colour of 30% is to be provided to all new doorways; including door frames (to clearly identify the difference between the door and the adjoining wall/door frame).
- + Accessible doorways in common areas are to achieve a minimum unobstructed clear width of 850mm (clear opening width does not include the door leaf thickness) and where there are double doors proposed, at least one leaf is to achieve this minimum clearance.
- + The circulation space around all accessible swinging doors is required to comply with Clause 13.3 and Figure 31 of AS 1428.1-2009. Circulation space requirements are to be detailed on the CC drawings – refer to Section 13 of AS1428.1-2009. Generally all doors require a clear space of 530mm at the latch side of the door and 110mm at the hinge side of the door to achieve compliance on a 'front on approach' accordingly.
- + All door handles and related hardware to swinging doorways are required to be a type 'D' handle which allows the door to be unlocked and opened with one hand in accordance with Clause 13.5.2.
- + The required accessible car spaces are to comply with AS 2890.6 – 2009.

Details demonstrating compliance and/or design certification are to be provided at the CC Application stage.

### **31. Clause D3.4 - Exemptions**

This part provides exemptions to the Deemed-to-Satisfy provisions for access by people with a disability. This part provides details on buildings or parts of buildings not required to be accessible under the BCA where providing access would be inappropriate because of the nature of the area or the tasks undertaken.

Comments: It is recommended that advice be obtained from the Access Consultant at the CC Application stage in this regard, however, consideration to an exemption for the warehouse areas including the warehouse mezzanine (on health & safety risk basis) may be appropriate on this project. In this regard, advice from an Access Consultant and Toyota will be required at CC Application stage

### **32. Clause D3.5 - Accessible Carparking**

This part provides details of the number of accessible carparking spaces required in a carpark depending on the classification of the building.

Comments: The proposed number of accessible car spaces shown on the referenced plans comply with BCA clause D3.5. The accessible car space must comply with AS/NZS 2890.6.

### **33. Clause D3.6 - Signage**

This section provides requirements for signage in buildings required to be accessible By Part D3.

Clear and legible Braille and tactile signage complying with Specification D3.6 and incorporating the international symbol of access in accordance with AS 1428.1 must identify:

- (i) (A) sanitary facility, and  
(B) space with a hearing augmentation system; and
- (ii) identify each door required by E4.5 to be provided with an exit sign and state—
  - (A) "Exit"; and
  - (B) "Level" followed by the floor level number; and

Where a pedestrian entrance is not accessible, directional signage incorporating the international symbol of access, in accordance with AS 1428.1 must be provided to direct a person to the location of the nearest accessible pedestrian entrance.

Where a bank of sanitary facilities is not provided with an accessible unisex sanitary facility, directional signage incorporating the international symbol of access in accordance with AS 1428.1 must be placed at the location of the sanitary facilities that



are not accessible, to direct a person to the location of the nearest accessible unisex sanitary facility.

**Comments:** Signage, including Braille & tactile signage where appropriate, is required to comply with BCA clause D3.6 and Section 8 of AS 1428.1-2009 for sanitary facilities, ambulant facilities and disabled car parking spaces. In addition, the signage to the accessible toilet facilities is to also identify the facility for left and right handed use.



### 34. Clause D3.8 - Tactile Indicators

This clause provides for the installation of tactile indicators in buildings required to be accessible and must be provided to warn people who are blind or have a vision impairment that they are approaching a stairway, escalator, passenger conveyor, ramp, overhead obstruction or an accessway meeting a vehicular way, except for areas exempted by D3.4.

**Comments:** Compliant tactile indicators are required in all areas of the buildings to all ramps, stairs, paths approaching a driveway and any overhead obstructions less than 2m in height.

AS 1428.4.1 tactile indicators are required to warn people with a vision impairment that they are approaching the following -

All stairs, (other than fire stairs)

A ramp (other than a step or kerb ramp).

Under any overhead obstruction less than 2-metres high (e.g. under non-enclosed stair treads).

Tactile indicators will need to be provided to the mezzanine stairway. Indicators must be Type B and installed in accordance with AS 1428.4.

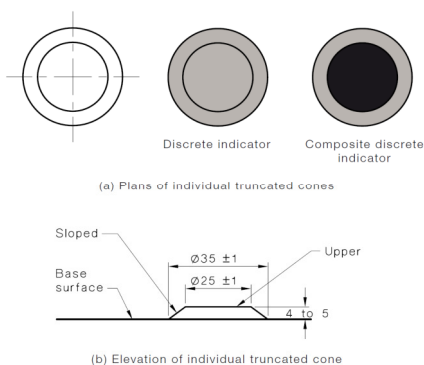

Source - Section 6.1 of AS1428.4-1992

### 35. Clause D3.11 - Ramps

Ramps may be used as part of an accessway where there is a change of level and must comply with the requirements set out in AS1428.1.



## **SECTION E – SERVICES AND EQUIPMENT**

### **FIRE FIGHTING EQUIPEMENT**

#### **36. Clause E1.3 -.Fire hydrants**

E1.3(a) – A fire hydrant system must be provided to serve a building having a total floor area greater than 500m<sup>2</sup> and where a fire brigade is available to attend a building fire.

E1.3(b) – Requires that the fire hydrant system must be installed in accordance with the provisions of AS2419.1 and also details where internal hydrants must be located.

*Comments: Fire hydrant locations are not identified on the referenced plans, however, the following should be noted:*

- + *The fire hydrant booster is NOT located within sight of the main entry of the building and as such requires an alternative solution from the Fire Engineer.*
- + *A Ring main in accordance with AS 2419.1-2005 must be provided.*
- + *Fire hydrants must be located externally in the first instance. Additional internal fire hydrants may then be provided for coverage – refer to fire engineer for advise on FRNSW location requirements.*
- + *The external fire hydrants must be positioned so that no point on the floor is more than 100m from a fire hydrant in order to satisfy fire brigade operational requirements. This may necessitate locating fire hydrants underneath the awnings, which in turn requires an Alternative Solution (refer to section C.2), and the provision of additional doors to the external walls.*

*Note: Hydraulic plans showing fire hydrant and hose reel locations will be required for submission with the Clause 144 Application to FRNSW.*

*Design Certification will be required from Hydraulic Consultant at the relevant CC stage.*

#### **37. Clause E1.4 – Fire hose reels**

A fire hose reel system must be provided to serve a building where one or more internal fire hydrants are installed or in a building with a floor area greater than 500m<sup>2</sup>.

This clause requires that the fire hose reel system must be installed in accordance with AS 2441 and sets out the detail for location and uses of fire hose reels.

*Comments: This fire safety measure is required for the building in accordance with BCA Clause E1.4 & AS 2441-2005. Design Certification will be required from Hydraulic Consultant at the relevant CC stage.*

#### **38. Clause E1.5 – Sprinklers**

A sprinkler system must be installed in a building or part of a building when required by Table E1.5 and comply with Specification E1.5. Table E1.5 sets out which types of building occupancies and Classes which require to have sprinkler systems installed in them.

Specification E1.5 sets out requirements for the design and installation of sprinkler systems.

*Comments: This fire safety measure is required for the building in accordance with BCA Spec. E1.5 & AS 2118.1-1999. Design Certification will be required from Fire Services Consultant at the relevant CC stage.*

#### **39. Clause E1.6 – Portable fire extinguishers**

Portable fire extinguishers must be provided as listed in Table E1.6 and must be selected, located and distributed in accordance with Sections 1, 2, 3 and 4 of AS 2444.

*Comments: This fire safety measure is required for the building in accordance BCA Clause E1.6 & AS 2444-2001. Design Certification will be required at the relevant CC stage.*



#### **40. Clause E1.8 – Fire Control Centres**

A fire control centre facility in accordance with Specification E1.8 must be provided for a building having an effective height of more than 25m and in a Class 6, 7, 8 or 9 building with a total floor area of more than 18,000m<sup>2</sup>.

Specification E1.8 describes the construction and content of required fire control centres or rooms.

*Comments: A Fire Control Centre is required for the building in accordance BCA Spec. E1.8. Design Certification will be required at the relevant CC stage.*

### **SMOKE HAZARD MANAGEMENT**

#### **41. Clause E2.2 – General Requirements**

Class 2 to 9 buildings must comply with the provisions of this Clause to remove smoke during a fire, to control the operation of air handling systems and to prevent the spread of smoke between compartments.

Buildings must comply with the provisions of **Table E2.2a**, as applicable to Class 2 to 9 buildings. It deals with the design and construction of air handling systems that are part of a smoke hazard management system and air handling system that are not part of a smoke hazard management system.

*Comments: As the large isolated building had a ceiling height of more than 12m an automatic smoke exhaust system is required. It is understood this system will be the subject of an Alternative Solution from the Fire Engineer.*

### **LIFT INSTALLATIONS**

#### **42. Clause E3.6 – Passenger Lifts**

The passenger lifts are required to be designed to comply with AS1735.2 and AS1735.12.

*Comments: Vertical access (passenger lift) is required to the first floor level of the two storey offices (other than the Dock Offices) due to the total floor area of the storey exceeding 200msq. In this regard a compliant 1400mm x 1100mm passenger lift will be required to be provided in accordance with the requirements of Part E3.*

### **EMERGENCY LIGHTING, EXIT SIGNS AND WARNING SYSTEMS**

#### **43. Clause E4.2 – Emergency Lighting Requirements**

This clause details when emergency lighting must be installed in Class 2 to 9 buildings. The requirements for buildings and parts of buildings are detailed in sub-clauses (a) to (i) and each sub-clause must be considered as more than one may apply to any single building

*Comments: This fire safety measure is required for the building in accordance with E4.2, E4.4 and AS/NZS 2293.1-2005.*

#### **44. Clause E4.4 – Design & Operation of Emergency Lighting**

Every required emergency lighting system must comply with AS2293.1.

*Comments: Electrical Consultant to note.*

#### **45. Clause E4.5 – Exit Signs**

An exit sign must be clearly visible to persons approaching the exit and must be installed on, above or adjacent to each door providing egress from a building. Sub-clauses (a) to (d) set out the situations where exit signs are required to be installed.

*Comments: Electrical Consultant to note.*



## **SECTION F – HEALTH & AMENITY**

### **SANITARY AND OTHER FACILITIES**

#### **46. Clause F2.3 – Facilities in Class 3 to 9 Buildings**

This clause provides the requirements for sanitary facilities to be installed in Class 3, 5, 6, 7, 8 and 9 buildings in accordance with Table F2.3. The requirements and variations are set out in sub-clauses (a) to (h).

*Comments: The current sanitary facilities detailed on the architectural plans are compliant with Table F2.3 for the proposed Staff Population numbers (referenced under D1.13 above).*

#### **47. Clause F2.4 – Accessible Sanitary Facilities**

Accessible unisex sanitary compartments must be provided within all areas of each unit in the building in accordance with the requirements of Table F2.4.

Each proposed accessible toilet has been counted once for each sex in accordance with BCA clause F2.6.

*Comments: The referenced plans show an adequate number of accessible and ambulant facilities in this regard - the layouts of which are to comply with AS 1428.1-2009.*

#### **48. Clause F2.5 – Construction of Sanitary Compartments**

- (a) Other than in an early childhood centre sanitary compartments must have doors and partitions that separate adjacent compartments and extend –
  - (i) from floor level to the ceiling in the case of a unisex facility; or
  - (ii) a height of not less than 1.5m above the floor if primary school children are the principal users; or
  - (iii) 1.8 above the floor in all other cases.
- (b) The door to a fully enclosed sanitary compartment must-
  - (i) open outwards; or
  - (ii) slide: or
  - (iii) be readily removable from the outside of the sanitary compartment,

*Comments: The construction of sanitary compartments must have doors and partitions 1.8 metres above floor level and doors to fully enclosed sanitary compartments must be removable from the outside where they swing inwards.*

## **LIGHT AND VENTILATION**

#### **49. Clause F4.4 – Artificial Lighting**

Artificial lighting is required where it is necessary to minimise the hazard to occupants during an emergency evacuation. Sub-clauses (a), (b) & (c) sets out the places where artificial lighting is always required in all classes of buildings and the standard to which it must be installed.

*Comments: All artificial lighting must comply with AS 1680. Mechanical ventilation must comply with AS 1668.2-1991.*

## **SECTION J – ENERGY EFFICIENCY**

### **50. PART J1 – BUILDING FABRIC**

The energy efficiency provisions of Section J are applicable to each building.

*Comments: A report will be required to be submitted prior to issue of the Construction Certificate which details how compliance is being achieved.*



## **51. PART J2 - GLAZING**

Glazing within the external building envelope will be required to be assessed/designed to achieve compliance with **Clauses J2.0 to J2.5**, including the **Tables therein**, having regard to the maximum aggregate air-conditioning energy attributable to each façade of the proposed building.

*Comments: This section applies to any air-conditioned spaces proposed within the building. A calculation demonstrating that the proposed design of the building complies with the requirements of **Part J2** is required to be submitted with the application for a Construction Certificate.*

## **52. PART J3 - BUILDING SEALING**

The proposed building envelope will be required to be sealed to prevent air infiltration in accordance with the requirements of **Clauses J3.0 to J3.6**. is required to be provided.

*Comments: This section applies to any air-conditioned spaces proposed within the building. Details or certification that the proposed building design complies with the requirements of **Part J3** will need to be submitted with the application for a Construction Certificate.*

## **53. PART J5 - AIR-CONDITIONING & VENTILATION SYSTEMS**

Details and/or design certification which confirm that any proposed air-conditioning system or unit within the proposed building achieves compliance with the relevant requirements of **Part J5** will be required to be provided from the Mechanical Engineer.

*Comments: Details or certification demonstrating compliance will need to be submitted with the application for a Construction Certificate.*

## **54. PART J6 - ARTIFICIAL LIGHTING & POWER**

Details and/or design certification which confirm that all artificial lighting, power control, and boiling/chilled water units within the proposed building achieves compliance with the relevant requirements of **Part J6** will be required to be provided from the Electrical Engineer.

*Comments: Consultant certification required at CC Application Stage - this requirements applies to the whole building regardless of the provision of air-conditioning in the various parts.*

## **55. PART J7 - HOT WATER SUPPLY & SWIMMING POOL & SPA POOL PLANT**

Details and/or design certification which confirm that any proposed hot water supply system within the proposed building achieves compliance with the relevant requirements of **Part J7** (Section 8 of AS 3500.4) will be required to be provided from the Hydraulic Engineer.

*Comments: Consultant certification required at CC Application Stage.*



## E. CONCLUSION

Based upon the above comments and our assessment of the referenced drawings it is considered that compliance with the relevant DTS provisions and Performance Requirements identified within this report are readily achievable, however full details demonstrating compliance are required to be submitted with the CC Application.

The following essential fire safety measures will be required for the building;

<b>Essential Fire and Other Safety Measures</b>	<b>Standard of Performance</b>
Alarm Signaling Equipment	AS1670.3 – 2004
Automatic Fail Safe Devices	BCA Clause D2.21
Automatic Fire Detection & Alarm System	BCA Spec. E2.2a & AS/NZS 1668.1 – 1998 and *Fire Engineered Alternative Solution
Automatic Fire Suppression Systems	BCA Spec. E1.5 & AS 2118.1-1999
Building Occupant Warning System activated by the Sprinkler System	BCA Spec E1.5 Clause 8 and/ or Clause 3.22 of AS 1670.1 – 2004
Emergency Lighting	BCA Clause E4.4 & AS 2293.1 - 2005
Exit Signs	BCA Clauses E4.5, E4.6 & E4.8 and AS 2293.1 – 2005 and *Fire Engineered Alternative Solution
Fire Control Centre	BCA Spec E1.8
Fire Hose Reels	BCA Clause E1.4 & AS 2441 – 2005
Fire Hydrant Systems	Clause E1.3 & AS 2419.1 – 2005 and *Fire Engineered Alternative Solution.
Mechanical Air Handling Systems	BCA Clause E2.2, AS/NZS 1668.1 - 1998 & AS 1668.2 – 1991
Paths of Travel	EP & A Regulation Clause 186
Perimeter Vehicular Access	BCA Clause C2.4 and*Fire Engineered Alternative Solution
Portable Fire Extinguishers	BCA Clause E1.6 & AS 2444 – 2001
Required Exit Doors (power operated)	BCA Clause D2.19(d)
Smoke Hazard Management Systems (Smoke Exhaust System)	BCA Part E2 & AS/NZS 1668.1 - 1998 *Fire Engineered Alternative Solution
Warning & Operational signs	Section 183 of the EP & A Regulations 2000, AS 1905.1 - 2005, BCA Clause C3.6, D2.23, E3.3 & H101.8

*Note the above fire safety schedule is indicative only and could be subject to change as result of design changes.*