



Consulting.TM
an Elephants Foot Company

3-5 Help St Chatswood
Mixed Use Development

OPERATIONAL WASTE MANAGEMENT PLAN

29/08/2025
Report No. 4712
SSD-7655711
Revision N

Client

Loftex Chatswood Pty Ltd

<https://loftexproperty.com/>

Architect

Embece

<https://embece.com.au/>



REVISION REFERENCE

Revision	Date	Prepared by	Description
A	5/01/2023	H Wilkes	Draft
B	9/03/2023	H Wilkes	Amendment
C	28/03/2023	H Wilkes	Amendment
D	31/05/2023	H Wilkes	Amendment
E	06/06/2023	H Wilkes	Final
F	18/11/2023	H Wilkes	Amendment
G	22/02/2024	H Wilkes	Amendment
H	26/02/2024	H Wilkes	Amendment
I	2/12/2024	H Wilkes	Draft Amendment – Up Lift
J	4/12/2024	H Wilkes	Amendment
K	6/12/2024	H Wilkes	Amendment
L	9/12/2024	H Wilkes	Final Amendment – Up Lift
M	5/03/2025	H Wilkes	Amendment
N	29/08/2025	H Wilkes	Amendment – RFI

The information contained in this document produced by Elephants Foot Consulting (EFC) is solely for the use of the client identified on the cover sheet for the purpose for which it has been prepared for. EFC undertakes no duty, nor accepts any responsibility for any third party who may rely upon this document. Reproduction, publication or distribution of this document without written permission from EFC is strictly prohibited.

TABLE OF CONTENTS

TABLE OF FIGURES	iv
LIST OF TABLES.....	iv
GLOSSARY OF ABBREVIATIONS AND TERMS	i
1.0 ACKNOWLEDGEMENT OF COUNTRY	3
2.0 INTRODUCTION.....	3
2.1 SCOPE OF REPORT	3
2.2 REPORT CONDITIONS	5
3.0 LEGISLATION & GUIDANCE.....	6
4.0 DEVELOPMENT OVERVIEW.....	7
4.1 SITE LOCATION.....	7
5.0 RESIDENTIAL WASTE MANAGEMENT	8
5.1 RESIDENTIAL WASTE GENERATION ESTIMATES.....	8
5.2 RESIDENTIAL BIN SUMMARY	9
5.3 CHUTE DISCHARGE EQUIPMENT SUMMARY	9
5.4 RESIDENTIAL WASTE DISPOSAL PROCEDURES.....	10
5.4.1 RESIDENTIAL GENERAL WASTE AND RECYCLING.....	10
5.4.2 RESIDENTIAL FOOD WASTE DISPOSAL PROCEDURES.....	10
5.5 RESIDENTIAL WASTE COLLECTION PROCEDURES.....	12
5.6 RESIDENTIAL BULKY WASTE PROCEDURES.....	13
6.0 COMMERCIAL AND RETAIL WASTE MANAGEMENT	14
6.1 COMMERCIAL AND RETAIL WASTE GENERATION ESTIMATES.....	14
6.2 RETAIL AND COMMERCIAL BIN SUMMARY	15
6.3 RETAL AND COMMERCIAL WASTE DISPOSAL PROCEDURES.....	15
6.4 OTHER RETAIL AND COMMERCIAL WASTE MANAGEMENT CONSIDERATIONS..	15
6.4.1 BATHROOMS	15
6.4.2 PROBLEM WASTE.....	15
6.5 RETAL AND COMMERCIAL WASTE COLLECTION PROCEDURES.....	16
7.0 STAKEHOLDER ROLES & RESPONSIBILITIES	17
8.0 SOURCE SEPARATION.....	18
9.0 EDUCATION	19
9.1 SIGNAGE.....	19
9.2 POLLUTION PREVENTION.....	20
10.0 BIN MOVING PATHS.....	20
11.0 EQUIPMENT SUMMARY	21
12.0 WASTE ROOMS	21
12.0 CONSTRUCTION REQUIREMENTS.....	23
12.1 ADDITIONAL CONSIDERATIONS	23

13.0	USEFUL CONTACTS.....	24
APPENDIX A:	ARCHITECTURAL PLANS.....	25
APPENDIX: A.1	LOWER GROUND FLOOR PLAN – WASTE AREAS.....	26
APPENDIX B:	INSTALLATION EQUIPMENT	27
APPENDIX: B.1	TYPICAL DUAL CHUTE SHAFT & PENETRATION SET-OUT.....	28
APPENDIX: B.2	TYPICAL LINEAR TRACK SYSTEM FOR 660L BINS	29
APPENDIX: B.3	TYPICAL LINEAR TRACK SYSTEM FOR 1100L BINS	31
APPENDIX C:	PRIMARY WASTE MANAGEMENT PROVISIONS.....	33
APPENDIX: C.1	TYPICAL BIN SPECIFICATIONS.....	34
APPENDIX: C.2	SIGNAGE FOR WASTE AND RECYCLING BINS.....	35
APPENDIX: C.3	TYPICAL COLLECTION VEHICLE INFORMATION.....	37
APPENDIX: C.4	TYPICAL BIN MOVERS	39
APPENDIX: C.5	TYPICAL SEATED BIN MOVERS.....	40
APPENDIX D:	SECONDARY WASTE MANAGEMENT PROVISIONS.....	42
APPENDIX: D.1	TYPICAL COOKING OIL CONTAINERS	43

TABLE OF FIGURES

Figure 1. Site Location.....	7
------------------------------	---

LIST OF TABLES

Table 1: Estimated Waste and Recycling Volumes – Residential.....	8
Table 2: Estimated Food Waste Volumes – Residential.....	9
Table 3: Estimated Waste and Recycling Volumes – Commercial and Retail Tenancies	14
Table 4: Stakeholder Roles and Responsibilities	17
Table 5: Operational Waste Streams.....	18
Table 6: Equipment Summary.....	21
Table 7: Waste Room Areas.....	21
Table 8: Waste Room Requirements.....	22

GLOSSARY OF ABBREVIATIONS AND TERMS

TERM	DESCRIPTION
<i>Bin-carting Route</i>	Travel route for transferring bins from the storage area to a nominated collection point
<i>Chute</i>	A ventilated, vertical pipe passing from floor to floor of a building with openings as required to connect with hoppers and normally terminating at its lower end at the roof of the central waste room(s)
<i>Chute Discharge</i>	The point at which refuse exits from the refuse chute
<i>Chute Discharge Room</i>	A secure, enclosed area or room housing the discharge and associated equipment for the refuse chute
<i>Collection Area/Point</i>	The identified position or area where general waste or recyclables are loaded onto the collection vehicle
<i>Compactor</i>	A machine for compressing waste into disposable or reusable containers
<i>DA</i>	Development Application
<i>DCP</i>	Development Control Plan
<i>EPA</i>	Environmental Protection Authority
<i>FOGO</i>	Food Organics and Garden Organics
<i>HRV</i>	Heavy Rigid Vehicle described by AS 2890.2-2002 Parking facilities – Off-street commercial vehicle facilities
<i>L</i>	Litre(s)
<i>LEP</i>	Local Environmental Plans guide planning decisions for local government areas
<i>Liquid Waste</i>	Non-hazardous liquid waste generated by commercial premises that must be connected to sewer or collected for treatment and disposal by a liquid waste contractor (including grease trap waste)
<i>Mixed Use Development</i>	A development comprised of two or more different uses
<i>MUD</i>	Multi-Unit Dwellings comprise of a development with more than one dwelling. This ranges from dual occupancies and attached dwellings to high-rise residential developments
<i>Mobile Garbage Bin(s) (MGB)</i>	A waste container generally constructed of plastic with wheels with a capacity in litres of 120, 240, 360, 660, 1000 or 1100
<i>MRV</i>	Medium Rigid Vehicle described by AS 2890.2-2002 Parking facilities – Off-street commercial vehicle facilities
<i>Onsite Collection</i>	When the collection vehicle enters the property and services the development within the property boundary from a designated loading area
<i>Owners Corporation</i>	An organisation or group of persons that is identified by a particular name and acts, or may act, as an entity

<i>Service Bins</i>	Bin set side to be placed under a chute while the remainder of the bins are being collected
<i>SRV</i>	Small Rigid Vehicle described by AS 2890.2-2002 Parking facilities – Off-street commercial vehicle facilities
<i>WHS</i>	Workplace Health and Safety
<i>Wheel-in wheel-out service</i>	A type of waste collection service offered by local councils where the council waste collection personnel enter the premises to collect the bins and returns them to the property

1.0 ACKNOWLEDGEMENT OF COUNTRY

We acknowledge Australia's First Nations People as the Traditional Custodians of this land. We pay respect to ancestors and Elders, past, present and emerging . We honour Aboriginal and Torres Strait Islander people and their connection to land, waters and seas.

2.0 INTRODUCTION

Elephants Foot Consulting (EFC) has been engaged to prepare the following waste management plan for the operational management of waste generated by the mixed use development located at 3-5 Help St Chatswood.

Waste management strategies and audits are required for new developments in order to support the design and sustainable performance of the building. It is EFC's belief that a successful waste management strategy contains three key objectives:

- i. **Promote responsible source separation** to reduce the amount of waste that goes to landfill by implementing convenient and efficient waste management systems.
- ii. **Ensure adequate waste provisions and robust procedures** that will cater for potential changes during the operational phase of the development.
- iii. **Comply** with all relevant council codes, policies, and guidelines.

To achieve these objectives, this operational waste management plan (OWMP) identifies the different waste streams likely to be generated during the operational phase of the development, as well as how the waste will be handled and disposed, details of bin sizes/quantities and waste rooms, descriptions of the proposed waste management equipment used, and information on waste collection points and frequencies.

It is essential that this OWMP is integrated into the overall management of the building and is clearly communicated to all relevant stakeholders.

2.1 SCOPE OF REPORT

This operational waste management plan (OWMP) only applies to the **operational** phase of the proposed development; therefore, the requirements outlined in this OWMP must be implemented during the operational phase of the site and may be subject to review upon further expansion of, and/or changes to the development.

The waste management of the **construction** and **demolition** phases of the development are not addressed in this report. A construction and demolition WMP will need to be provided separately.

2.2 PLANNING SECRETARY'S ENVIRONMENTAL ASSESSMENT REQUIREMENTS – 17. WASTE MANAGEMENT

The following table identifies the relevant SEARs items and where these are addressed in this report for SEARs submission SSD 76555711:

Table 1: SEARs Items- 17 Waste Management

Item	Corresponding Section
Identify, quantify and classify the likely waste streams to be generated during construction and operation.	Section 5.1, Section 6.1 and Section 8.0 of the OWMP
Provide the measures to be implemented to manage, reuse, recycle and safely dispose of waste in accordance with any council waste management requirements.	Sections 5 to Section 10 of the OWMP
Identify appropriately sited waste storage areas, collection access paths/roads, and appropriate servicing arrangements for the site.	Sections 5.5, 6.5 and Section 12 of the OWMP
If buildings are proposed to be demolished or altered, provide a hazardous materials survey.	The Hazardous Material Survey is not relevant to this Report. A hazardous Material Survey has been completed by Douglas Partners in a separate report

2.3 REPORT CONDITIONS

The purpose of this report is to document an OWMP as part of a development application, which is supplied by EFC with the following limitations:

- Drawings, estimates and information contained in this OWMP have been prepared by analysing the information, plans and documents supplied by the client and third parties including Council and other government agencies. The assumptions based on the information contained in the OWMP is outside the control of EFC,
- The figures presented in the report are an estimate only – the actual amount of waste generated will be dependent on the occupancy rate of the building/s and waste generation intensity as well as the building management's approach to educating residents and tenants regarding waste management operations and responsibilities,
- The building manager will adjust waste management operations as required based on actual waste volumes (e.g. if waste is greater than estimated) and increase the number of bins and collections accordingly,
- The report will not be used to determine or forecast operational costs or prepare any feasibility study or to document any safety or operational procedures,
- The report has been prepared with all due care; however no assurance is made that the OWMP reflects the actual outcome of the proposed waste facilities, services, and operations, and EFC will not be liable for plans or results that are not suitable for purpose due to incorrect or unsuitable information or otherwise,
- EFC offer no warranty or representation of accuracy or reliability of the OWMP unless specifically stated,
- Any manual handling equipment recommended in this OWMP should be provided at the recommendation of the appropriate equipment provider who will assess the correct equipment for supply,
- Design of waste management chute equipment and systems must be approved by the supplier,
- EFC cannot be held accountable for late changes to the design after the OWMP has been submitted to Council,
- EFC will provide specifications and recommendations on bin access and travel paths within the OWMP, however it is the architect's responsibility to ensure the architectural drawings meet these provisions,
- EFC are not required to provide information on collection vehicle swept paths, head heights, internal manoeuvring or loading requirements. It is assumed this information will be provided by a traffic consultant,
- Council are subject to changing waste and recycling policies and requirements at their own discretion.

This OWMP is only finalised once the Draft Watermark has been removed. If the Draft Watermark is present, the information in the OWMP is not confirmed.

3.0 LEGISLATION & GUIDANCE

Waste management and resource recovery regulation in Australia is administered by the Australian Constitution, Commonwealth laws, and international agreements. State and territory governments maintain primary responsibility for controlling development and regulating waste. The following legislation has been enacted in New South Wales, and provides the lawful underpinnings of this OWMP.

- NSW Environmental Planning & Assessment Act 1979
- NSW Protection of the Environment Operations Act 1997
- NSW Waste Avoidance & Resource Recovery Act 2001

At the local level, councils or Local Government Areas (LGAs) require OWMPs to be included in new development applications. This OWMP is specifically required by:

- Willoughby Development Control Plan 2023
- Willoughby Local Environmental Plan 2012

The primary purpose of a development control plan (DCP) is to guide development according to the aims of the corresponding local environmental plan (LEP). The DCP must be read in conjunction with the provisions of the relevant LEP.

Information provided in this OWMP comes from a wide range of waste management guidance at the local, state, and federal levels. The primary sources of guidance include:

- North Sydney Regional Organisation of Councils (NSROC): Waste Management Technical Guide and Development Controls 2018
- NSW Better Practice Guidelines for Waste Management and Recycling in Commercial and Industrial Facilities 2012
- NSW Better practice guide for resource recovery in residential developments 2019
- NSW Waste Avoidance and Resource Recovery (WARR) Strategy 2014-2021
- NSW Waste Classification Guidelines 2014
- Australia's National Waste Policy 2018

4.0 DEVELOPMENT OVERVIEW

The proposed development falls under the LGA of Willoughby City Council, and consists of:

- One building with 35 levels and 5 basement levels
 - 160 residential units in total
 - 2 Commercial (retail) tenancies with a total NLA of 352 m²
 - Commercial (office) tenancies with a total NLA of 1960 m²

All figures and calculations are based on area schedules as advised by our client and shown on architectural drawings

4.1 SITE LOCATION

The site is located at 3-5 Help St Chatswood, as shown in Figure.1 (boundaries are indicative only). The site has frontages to Cambridge Ln, McIntosh St and Help St, with vehicle access via Help St.

Figure 1: Site Location

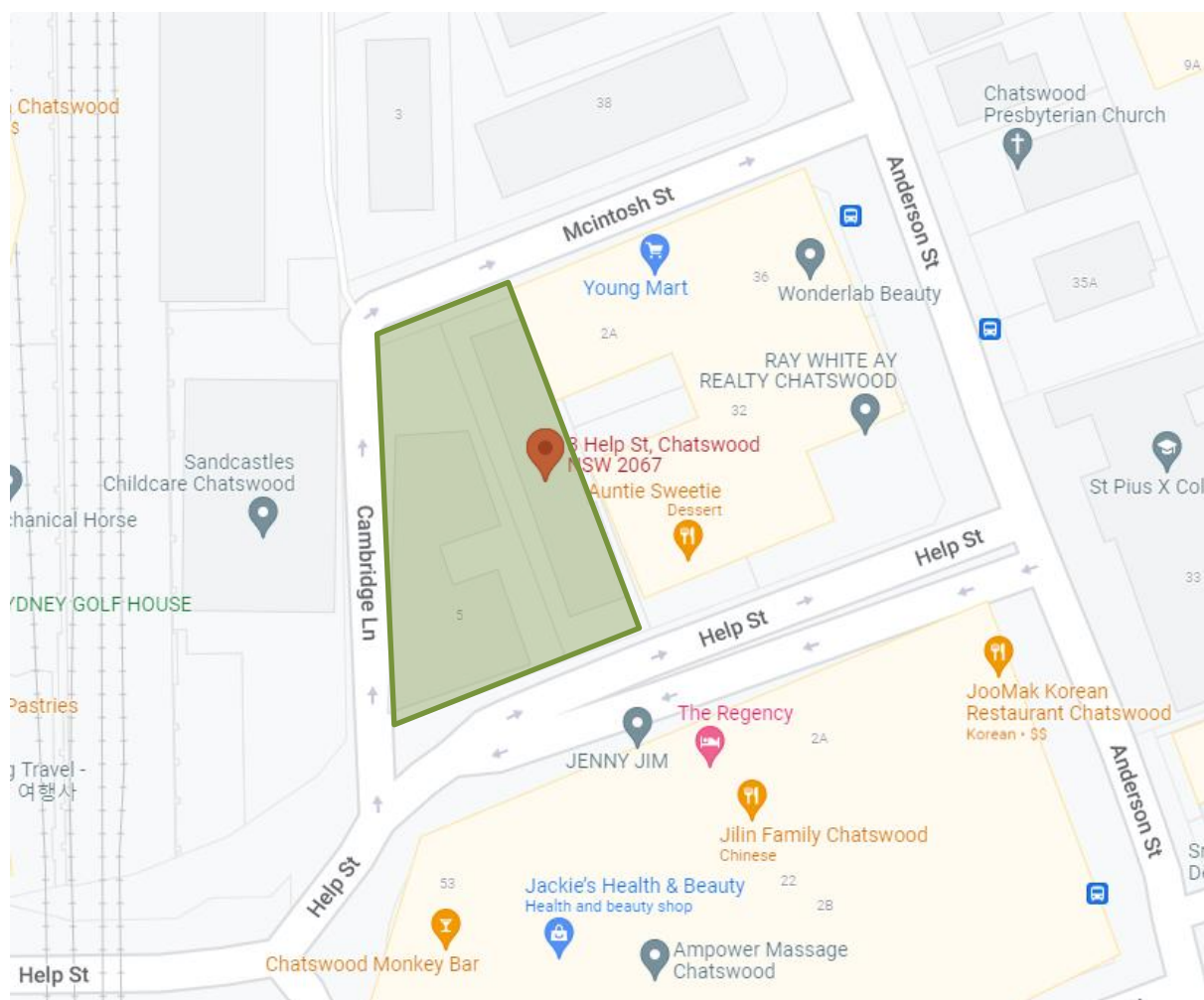

Source: Google Maps

5.0 RESIDENTIAL WASTE MANAGEMENT

The following section outlines best practice waste management for the residential component of the development, including waste generation estimates, and waste disposal and collection procedures.

5.1 RESIDENTIAL WASTE GENERATION ESTIMATES

The *Willoughby Development Control Plan 2023*, North Sydney Regional Organisation of Councils (NSROC): *Waste Management Technical Guide and Development Controls 2018* and has been referenced to calculate the total number of general waste and recycling bins required for the residential units.

The *NSW EPA's Better Practice Guide For Resource Recovery In New Development 2019* and has been referenced to calculate the total number of Food Organics and Garden Organics (FOGO) required for the residential units. This document has been used as site is predominantly units without gardens, thus most of the organic waste coming from the units would be food waste. North Sydney Regional Organisation of Councils (NSROC): *Waste Management Technical Guide and Development Controls 2018*, only includes a rate for Garden Organics. Thus the rate *NSW EPA's Better Practice Guide For Resource Recovery In New Development 2019* has been deemed to be a better representation of the waste composition/profiles of this development.

Calculations are based on generic waste, recycling, FOGO rates. Actual volumes of waste and recycling generated in operation may differ according to the residents' actual waste management practices.

The following table shows the estimated volume (L) of general waste and recyclables generated by the residential component of the development.

Table 2: Estimated Waste and Recycling Volumes – Residential

# Units	General Waste Generation Rate (L/unit/week)	Generated General Waste (L/week)	General Waste Compacted (2:1)	Recycling Generation Rate (L/unit/week)	Generated Recycling (L/week)
160	140	22400	11200	120	19200
TOTAL		22400	11200		19200
Bins and Collections	General Waste Bin Size (L)		660	Recycling Bin Size (L)	1100
	General Waste Bins per Week		17	Recycling Bins per Week	17.35
	General Waste Collections per Week		2	Recycling Collections per Week	1
	Total General Waste Bins Required for Collection		9	Total Recycling Bins Required for Collection	18
	Number of Waste Bins Per Day		2.42	Number of Recycling Bins Per Day	2.48

****Note:** It is strongly recommended bins/equipment at the base of each chute allow for 2-days' worth of waste or recycling generation.

Table 3: Estimated Food Waste Volumes – Residential

Bedrooms	# Units	FOGO Waste Generation Rate	Generated FOGO Waste
		(L/unit/week)	(L/week)
Studio, 1 bed or 2 Bed	144	25	3600
3+ bed	16	50	800
TOTAL	160		4400
Bins and Collections		FOGO Bin Size (L)	240
		FOGO Bins per Week	18.33
		FOGO Collections per Week	1
		Total FOGO Bins Required for Collection	<u>19</u>

Note: At the time of writing, Council do not have an active FOGO collection service for MUDs. Provision for FOGO bins at this development have been included to account for a future FOGO collection service.

5.2 RESIDENTIAL BIN SUMMARY

Based on the estimated waste generated by the residential component of this development, the recommended bin quantities and collection frequencies are as follows:

General Waste: 9 x 660L bins collected **2 x weekly**

Recycling: 18 x 1100L bins collected **1 x weekly**

Food Waste: 19x 240L bins collected **1x weekly**

Service Bins: 1x 1100L bin & 1x 660L bin

During operation, it is the responsibility of the building manager to monitor the number of bins required for the residential component. Waste and recycling volumes may change according to residents' attitudes to waste disposal and recycling, building occupancy levels or development's management. Any requirements for adjusting the capacity of the waste facilities can be achieved by changing the number of bins, the bin sizes or collection frequencies. Building management will be required to negotiate any changes to bins or collections with the collection service provider.

5.3 CHUTE DISCHARGE EQUIPMENT SUMMARY

It is strongly recommended that the bins and equipment at the base of each chute allows for at least 1 days' worth of waste and recycling generation. Based on the estimated waste and recycling generated by each core, the follow equipment is recommended:

Waste Chute: 1x 3-Bin 660L bin Linear System with compactor will hold **1 day's waste**

Recycling Chute: 3x 2-Bin 1100L bin Linear System will hold **1 day's recycling**

In addition to this equipment, it is recommended that the service bins are stored in the chute discharge rooms.

The equipment recommended in the Chute Discharge Rooms is to manage 2 days' worth of estimated waste and recycling volumes from that building core. Therefore, this represents the minimum equipment required in these rooms to satisfy best practice requirements. More bins or large volume handling equipment can be included in these rooms to increase days of capacity or manual labour required in operation.

5.4 RESIDENTIAL WASTE DISPOSAL PROCEDURES

The following sections outline the procedures the residents will follow to dispose of general waste, recycling and FOGO.

5.4.1 RESIDENTIAL GENERAL WASTE AND RECYCLING

Dual chute systems, comprising a waste chute and a recycling chute will be installed with access provided on each residential level.

The residents will be responsible for walking their waste and recycling to the disposal point on their level and placing the waste and recycling into the correct chutes.

Residents will wrap or bag their general waste before placing in the waste chute. Bagged waste should not exceed 3kg in weight, or 35cm x 35cm x 35cm. Recycling (comingle only) must not be bagged when disposed of into the recycling chute as soft plastic is a contaminate to recycling. Cardboard boxes or large containers should also not be disposed of in the chute and a separate cardboard collection bins must be made available and managed by the building caretaker.

The general waste will discharge from the waste chute into 660L bins on linear tracks and will be compacted. This report assumes general waste will be compacted at a rate of 2:1. The comingled recyclable chute will discharge into 1100L bins on linear tracks in the Chute Discharge Room.

Refer to Council guidance for the types of materials accepted in the general waste and recycling streams.

5.4.2 RESIDENTIAL FOOD WASTE DISPOSAL PROCEDURES

In units the majority of organics waste generated is food waste rather than garden waste. As such the management recommendation and calculations throughout this report takes into account the Food Waste bins will primarily be food organics.

The building will be provided with a Communal Food Bin Room which contains 240L bins for food waste. The residents will be responsible for walking their food waste down to the Communal Food Waste Bin Room and placing it into the bins.

Food waste must be contained in accordance with Willoughby Council's future food waste collection service procedures (for example a compostable liner). Upon moving in, the residents of each dwelling will be provided with a caddy for separating and containing food waste within their kitchens.

Building management is responsible for ensuring that the Communal Food Bin Room and food waste bins are washed down frequently and ensuring that hygiene and odour is maintained.

5.5 RESIDENTIAL WASTE COLLECTION PROCEDURES

Council will be engaged to collect the residential waste and recycling in accordance with Council's collection schedule. This report assumes waste will be collected twice weekly and recycling will be collected weekly.

On the nominated waste collection day, the building caretaker will be responsible for transporting all the bins to the Residential Bin Holding Room on the Lower Ground level. It is recommended that extra 660L and 1100L service bins are placed under the chute to collect discharge while the other bins are being serviced.

To service the bins, a Council collection vehicle will enter the site from Help St and park in the loading bay adjacent to the Residential Bin Holding Room. The waste collection staff will collect the bins from the Residential Bin Holding Room via a collect and return arrangement.

Once the bins are serviced, the collection vehicle will exit the site onto Help St in a forward direction.

It is the responsibility of the caretaker to ensure that the loading area is clear of any vehicles or obstructions prior to waste collection. When waste

collection is complete, the building caretaker will return the bins to their operational location resume use.

5.6 RESIDENTIAL BULKY WASTE PROCEDURES

An area will be made available for the storage of discarded residential bulky items (e.g. whitegoods, furniture, etc.). This room should be located within close proximity of the garbage and recycling bin collection room and must have a minimum doorway width of 1.5m to allow for easy movement of large waste items in and out of the room.

Willoughby Council requires that size of the Bulky Waste Room provided is proportional to the number of units in the building at a rate of 10m² for the first 40 units then 2m² for every 10 units thereafter at per the *NSROC Waste Management Guidelines 2018*

Based on this rate, the bulky waste room required for each lot is as follows;

Bulky Waste Room Size

$$\begin{aligned} & (\text{Total number of units} - 40) / 10 * 2 + 10 = \text{m}^2 \text{ of bulky waste room} \\ & (160 - 40) / 10 * 2 + 10 = \\ & = 120 / 10 * 2 + 10 \\ & = 12 * 2 + 10 \\ & = 24 + 10 \\ & = 34 \end{aligned}$$

bulky waste storage area: minimum 34m²

Residents will need to liaise with building management regarding the transportation of bulky items and the availability of the Bulky Waste Storage Room. It is the Building Manager's responsibility to arrange collection dates with Council and then coordinate with the residents.

On the day of bulky waste collection, a Council collection vehicle will enter the site from Help St and park in the loading bay. The building caretaker will provide the driver with access to the Bulky Waste Storage Room. Once bulky items have been loaded, the collection vehicle will exit the site onto Help St in a forward direction. Refer to Council's website for acceptable items and other information regarding bulky waste collection.

6.0 COMMERCIAL AND RETAIL WASTE MANAGEMENT

The following section outlines best practice waste management for the commercial and retail components of the development, including waste generation estimates and waste disposal and collection procedures.

6.1 COMMERCIAL AND RETAIL WASTE GENERATION ESTIMATES

The NSW EPA's *Better Practice Guide for Resource Recovery in Residential Development 2019* has been referenced to calculate the total number of bins required for the anticipated tenants. Calculations are based on generic figures, and waste generation rates may differ according to the tenants' actual waste management practice.

The following table shows the estimated volume (L) of general waste and recyclables that will be generated by the commercial and retail tenants. It is assumed that retail and commercial tenancies will share waste bins, the waste storage room, and the waste collection service. The following estimates are based on a seven-day operating week for the retail tenancies and a five-day operating week for the commercial tenancies.

Table 4: Estimated Waste and Recycling Volumes – Commercial and Retail Tenancies

Tenancy	Waste Generation Rate Type	NLA (m ²)	General Waste Generation Rates (L/100m ² /day)	Generated Garbage (L/week)	Recycling Generation Rate (L/100m ² /day)	Generated Recycling (L/week)
Commercial (L1 & Mezz)	Office	1960	10	980	15	1470.00
Retail LG	Retail: Other Non Food	191	50	668.5	100	1337.00
Retail UG	Retail: Other Non Food	161	50	563.5	100	1127.00
TOTAL		2312		2212		3934.00
Equipment and Collections		General Waste Bin Size (L)		1100	Recycling Bin Size (L)	1100
		General Waste Bins Per Week		3	Recycling Bins Per Week	4
		General Waste Collections per Week		2	Recycling Collections per Week	2
		Total General Waste Bins Required		2	Total Recycling Bins Required	2

6.2 RETAIL AND COMMERCIAL BIN SUMMARY

Based on the estimated waste and recycling generated by the retail and commercial tenancies, the recommended bin quantities and collection frequencies are as follows:

General Waste: 2 x 1100L bins collected **2 x weekly**

Recycling: 2 x 1100L bins collected **2 x weekly**

Bin sizes, quantities, and/or collection frequencies may be modified by the building manager once the proposed development is operational. Building management will be required to negotiate any changes to bins or collections with the collection service provider. Seasonal peak periods such as public and school holidays should also be considered.

6.3 RETAL AND COMMERCIAL WASTE DISPOSAL PROCEDURES

The retail and commercial tenancies will share bins, bin room and collection service. Each tenancy is responsible for their back of house waste management within their tenancy. On completion of each trading day or as required, nominated staff or contracted cleaners will transport all general waste and recyclables to the Retail/Commercial Bin Room and place into the appropriate collection bins.

6.4 OTHER RETAIL AND COMMERCIAL WASTE MANAGEMENT CONSIDERATIONS

Based on the types of tenancies anticipated for this development, the following waste management practices are recommended.

6.4.1 BATHROOMS

Washroom facilities should be supplied with collection bins for paper towels (if used). Sanitary bins for female restroom facilities must also be arranged with an appropriate contractor.

6.4.2 PROBLEM WASTE

The building manager is responsible for making arrangements for the disposal and recycling of problem waste streams with an appropriate contractor. Problem wastes cannot be placed in general waste as they can have adverse impacts to human health and the environment if disposed of in landfill. Retail and commercial tenants will need to liaise with the building manager when disposing of problem waste streams.

Problem waste streams include:

- Chemical Waste
- Liquid wastes
- Toner cartridges
- Lightbulbs
- eWaste
- Batteries

6.5 RETAIL AND COMMERCIAL WASTE COLLECTION PROCEDURES

A private waste collection contractor will be engaged to service the retail waste and recycling bins per an agreed schedule. This report assumes waste and recycling is collected three times weekly.

On the day of service, a private waste collection vehicle will enter the site from Help St and park in the loading bay. The Waste Collection Staff will collect the bins directly from the Commercial/Retail Bin Room via a collect and return arrangement. Once the bins are serviced, the collection vehicle will exit the site onto Help St in a forward direction.

Please note that the collection of commercial/retail bins should occur on separate days from the collection of residential bins minimise conflicting uses of the loading area.

7.0 STAKEHOLDER ROLES & RESPONSIBILITIES

The following table demonstrates the primary roles and responsibilities of the respective stakeholders:

Table 5: Stakeholder Roles and Responsibilities

Roles	Responsibilities
Strata, Body Corporate or Management	<ul style="list-style-type: none"> • Ensure all waste service providers submit monthly reports on all equipment movements and waste quantities/weights; • Organise internal waste audits/visual assessments on a regular basis • Purchase any on-going waste management equipment or maintenance of equipment once building is operational; and • Manage any non-compliances/complaints reported through waste audits.
Building Manager or Waste Caretaker	<ul style="list-style-type: none"> • Maintain and clean chute doors on each level; • Coordinate general waste and recycling collections; • Clean and transport bins as required; • Organise replacement or maintenance requirements for bins; • Organise, maintain and clean the waste holding area; • Organise bulky goods collection when required • Investigate and ensure prompt clean-up of illegally dumped waste materials. • Prevent storm water pollution by taking necessary precautions (securing bin rooms, preventing overfilling of bins) • Abide by all relevant WH&S legislation, regulations, and guidelines; • Provide staff/contractors with equipment manuals, training, health and safety procedures, risk assessments, and PPE to control hazards associated with all waste management; • Assess any manual handling risks and prepare a manual handling control plan for waste and bin transfers; • Ensure site safety for residents, children, visitors, staff and contractors; and • Ensure effective signage, communication and education is provided to occupants, tenants, maintenance staff, and cleaning contractors.
Residents	<ul style="list-style-type: none"> • Dispose of all general waste and recycling in the allocated waste chutes and/or MGBs provided; • Ensure adequate separation of general waste and recycling; and • Compliance with the provisions of Council and the OWMP.
Retail/Commercial Tenants	<ul style="list-style-type: none"> • Manage the back of house storage of generated waste and recycling during daily operation. • Correctly separate waste and recycling streams; bag general waste and ensure recyclables are not bagged. • Flatten cardboard within the recycling bin. • If required, make arrangements for storing used and unused cooking oil in a bunded storage area, • Organise grease interceptor trap servicing, • Ensure dry basket arrestors are provided to the floor wastes in the food preparation, and • Ensure the suitable storage for chemicals, pesticides and cleaning products waste back of house.
Waste Collection Contractor	<ul style="list-style-type: none"> • Provide a reliable and appropriate waste collection service; • Provide feedback to building managers/residents regarding contamination of recyclables; and • Work with building managers to customise waste systems where possible.
Gardening/Landscaping Contractor	<ul style="list-style-type: none"> • Remove all garden organic waste generated during gardening maintenance activities for recycling at an offsite location.
Developer	<ul style="list-style-type: none"> • Purchase all equipment required to implement this OWMP prior to the occupation of the building to be provided to the strata/body corporate.

8.0 SOURCE SEPARATION

Better practice waste management includes the avoidance, reuse, and recovery of unwanted items, which can be achieved through source separation. The table below outlines what is typically included in various waste streams and how they can be managed. Refer to your local council for a list of accepted materials. Planet Ark can be accessed online to find other facilities that recover unwanted items.

Table 6: Operational Waste Streams

Waste Stream	Description	Typical Destination	Waste Stream Management
General Waste	The remaining portion of the waste stream that is not recovered for reuse, processing, or recycling. May include soft plastics, food scraps, polystyrene, etc.	Landfill	Waste should be bagged before placing in chutes, or in designated waste bins.
Recycling	A mixture of items that are commonly recycled usually segregated through a MRF. Typically include food and beverage containers (e.g. aluminium, glass, steel, hard plastics, cartons). Also included cardboard and paper products.	Resource Recovery Centre	Recycling must not be bagged, and instead should be placed loosely in the recycling chute or in designated recycling bins. Bulky cardboard must not be placed in any chute. Cardboard should be flattened before placing in the designated cardboard bin.
Green Waste	Green waste consists of unwanted organic materials that are easily biodegradable and/or compostable (e.g. lawn clippings, branches)	Resource Recovery Centre	Landscape Maintenance Contractors will remove the green waste from site during scheduled maintenance.
Food Waste	Food waste consists of unwanted or uneaten kitchen scraps that are easily compostable/biodegradable (e.g. vegetable peels, fruit rinds, coffee grounds).	Composting facility or Landfill	Food waste can be composted on-site, off-site, or else included in the general waste stream.
Electronic Waste	Discarded e-waste, electronic components and materials such as computers, mobile phones, keyboards, etc.	Resource Recovery Centre	Building manager arranges collection for e-waste recycling as needed by residents. Commercial tenants arrange for recycling of their own e-waste.
Bulky Items	Items that are too large to place into general rubbish collection. This includes disused and/or broken furniture, mattresses, white goods, etc.	Resource Recovery Centre or Landfill	Residents liaise with building manager to store in Bulky Goods Room. Building manager arranges with Council for removal. Commercial tenants are responsible for removal of their bulky items.
Sanitary Waste	Feminine hygiene waste generated from female bathrooms.	Incineration or Landfill	Sanitary bins are serviced by sanitary waste contractor.
Other	Other recyclable items that require special recovery may include ink cartridges, batteries, chemical waste, fluorescent tubes, etc.	Resource Recovery Facility	Building manager arranges collection by appropriate recycling services when required.

9.0 EDUCATION

Educational materials encouraging correct separation of general waste and recyclables must be provided to each resident and commercial/retail tenant. This should include the correct disposal process for bulky waste such as old furniture, large discarded items, and other materials including electronic and chemical wastes. It is recommended that the building caretaker provides information in multiple languages to support correct behaviours, and to minimise the possibility of chute blockages and contamination in communal waste bins.

Education and communication must be provided consistently on a regular basis to encourage behaviour change and account for transient building personnel such as new residents, tenants, or cleaning staff. It is also recommended that the owners' corporation website contain information for residents' referral regarding use of the chute. Information should include:

- Directions on using the chute doors;
- Descriptions of items accepted in the recycling and general waste streams (refer to Council guidance);
- How to dispose of bulky goods and any other items that are not general waste or recycling (refer to Council guidance);
- Residents' obligations to health and safety as well as building management; and
- How to prevent damage or blockages to the chute (example below).

To prevent damage or blockage to rubbish chute DO NOT dispose of any umbrellas, bedding, cigarettes, cartons, coat hangers, brooms, mops, large plastic wrappings from furniture, white goods, any sharp objects, hot liquid or ashes, oil, unwrapped vacuum dust, syringes, paint and solvents, car parts, bike parts, chemicals, corrosive and flammable items, soil, timber, furniture, bricks or other building materials down the chute.

9.1 SIGNAGE

Signage and education are essential components to support best practice waste management including resource recovery, source separation, and diversion of waste from landfill.

The building manager is responsible for waste room signage including safety signage. Appropriate signage must be prominently displayed on doors, walls and above all bins, clearly stating what type of waste or recyclables is to be placed in each bin. Signage should include:

- Clear and correctly labelled waste and recycling bins,
- Instructions for separating and disposing of waste items. Different languages should be considered,
- Locations of, and directions to, the waste storage areas with directional signs, arrows, or lines,
- The identification of all hazards or potential dangers associated with the waste facilities, and
- Emergency contact information should there be issues with the waste systems or services in the building.

All chute doors on all residential levels will be labelled with signs directing chute operations and use of chute door.

All signage should conform to the relevant Australian Standards.

9.2 POLLUTION PREVENTION

Building management shall be responsible for the following to minimise dispersion of site litter and prevent stormwater pollution to avoid impact to the environment and local amenity:

- Promoting adequate waste disposal into the bins
- Securing all bin rooms (whilst affording access to staff/contractors)
- Prevent overfilling of bins, keep all bin lids closed and bungs leak-free
- Taking action to prevent dumping or unauthorised use of waste areas
- Require collection contractor/s to clean up any spillage when clearing bins

10.0 BIN MOVING PATHS

The building manager is responsible for the transportation of bins as required from their designated operational locations to the bin holding room as required and returning them once emptied to resume operational use.

Transfer of bins should minimise manual handling where possible, as bins become heavy when full. The building manager must assess manual handling risks and provide any relevant documentation to key personal.

The routes along the bin moving path should;

- Allow for a continuous route that is wholly within the property boundary.
- Be free from obstruction and obstacles such as steps and kerbs.
- Be constructed of solid materials with a non-slip surface
- Be A minimum of 300mm wider than the largest bin used onsite.
- If bins are moved manually, the route must not exceed a grade of 1:14.
- If a bin moving device is used, the route cannot exceed the maximum operating grade of the device. This is typically a grade of 1:4, however this will vary depending on the model of bin moving device acquired for the site.

The developer is responsible for supplying all equipment required for moving bins this includes any bin lifters, bin moving devices and waste transfer bins. This equipment must be new and appropriate for the site. The developer should contact a bin-tug, trailer or tractor consultant to provide equipment recommendations.

Once the site is operational (and the developers is no longer involved) the building proprietors/strata/body corporate will be responsible for maintaining, repairing and replacing waste management equipment.

11.0 EQUIPMENT SUMMARY

Table 7: Equipment Summary

	Part	Qty	Notes
Chutes	Please refer to supplier's information	2	(See Appendix B.1 for Typical Dual Chute Layout)
Chute Equipment	Waste 2-bin 660L MGB Linear Track System with Compactor	1	See Appendix B.2 & B.3 for Typical Linear System information
	Recycling 2-bin 1100L MGB Linear Track System	1	
Other Equipment	Suitable Bin Moving Equipment	Optional	See APPENDIX C.4 for Typical Bin Movers

12.0 WASTE ROOMS

The areas allocated for waste storage and collection areas are detailed in the table below, and are estimates only. Final areas will depend on room and bin layouts.

Table 8: Waste Room Areas

Level	Waste Room Type	Equipment	Estimated Area Required (m ²)	Personnel permitted access to Room
LG	Residential Chute Discharge Room and Residential Bin Holding Room (Collection Point)	<i>Caged Off – Chute Discharge & Equipment</i> 1x 3-bin linear with compactor for 660L bins (waste) 1x 3-bin linear for 1100L bins (recycling)	Equipment footprint only: 70.2	<ul style="list-style-type: none"> • Building Manager • Collection Staff
		<i>Outside of Caging – Collection Point</i> 9x 660L bins (Waste) 18x 1100L bins (Recycling) 19x 240L bins (Food Waste)	Equipment footprint + addition 80% for access allowance : >134	
LG	Communal Food Bin Room	<i>Minimum</i> 10x 240L bins (Food Waste)	>10	<ul style="list-style-type: none"> • Building Manager • Residents
LG	Bulky Waste Storage Room	1x 1100L bins (Recycling – bulky cardboard) 6m ² charity donation storage	>34	<ul style="list-style-type: none"> • Building Manager • Residents • Collection Staff
LG	Retail/ Commercial Bin Room	2x 1100L bins (waste) 2x 1100L bins (recycling)	>17	<ul style="list-style-type: none"> • Building Manager • Retail/ Commercial tenancy staff • Collection Staff

The waste room areas have been calculated based on equipment requirements and/or bin dimensions with an additional 80% of bin GFA factored in for manoeuvrability.

In addition, all doorways and passageways facilitating the movement of bins and/or bulky waste items must be at least 1600mm wide.

The following table provides further waste room requirements.

Table 9: Waste Room Requirements

Waste Room Type	Waste Room Requirements
Chute Discharge Room	<ul style="list-style-type: none"> • Ceiling clearance height must be a minimum of 3000mm • The chute penetration must have a minimum 500mm clearance of any service pipes or other overhead obstacles (subject to penetration location) • All waste discharge points should be caged off to ensure the safety of any personnel accessing the waste room • 200mm clearance is required around compaction equipment • Where a chute offset is required, the angle of the offset must not exceed 30 degrees (Subject to number of consecutive offset and/pr up to 1500mm) • Where two sets of volume management equipment are placed under the chutes, a 200mm clearance is required between the equipment. • Where the chute discharge room also acts as the collection point, the chute discharge and any equipment underneath the chute should be caged off to ensure the safety of personnel accessing the room.
Communal Food Bin Rooms	<ul style="list-style-type: none"> • Bins should be arranged so that all bins are accessible. Bins are not to be placed in front of one another or in such a way as to restrict access to the other bins for use. • Rooms must be well ventilated either naturally or mechanically in accordance with AS1668.4.2012 • Cleaning facilities such as hose hock and drainage for odour and hygiene control must be provided. • It is recommended a dustpan and broom is provided in this room for residents to clean up unexpected spillages when using bins
Residential Bin Holding Room and/or Bin Collection Area	<ul style="list-style-type: none"> • Bins must not be stacked in rows that are more than two bins deep
Bulky Waste Storage Room	<ul style="list-style-type: none"> • May be a dedicated room or screened area within another waste room • Must be in close proximity to the collection area • Area must also be allocated for the segregation of e-waste, gas bottles, cardboard, etc. • Doorway should be a minimum of 1500mm wide
Retail/Commercial Bin Room	<ul style="list-style-type: none"> • In order to ensure staff safety, all bins should be arranged so they can be accessed without moving another bin

12.0 CONSTRUCTION REQUIREMENTS

Waste room construction must comply with the minimum standards as outlined in the *Willoughby Development Control Plan 2023*, in order to minimise odours, deter vermin, protect surrounding areas, and make it a user-friendly and safe area.

The *NSW Better practice guide for resource recovery in residential developments (2019)* also states that better practice bin storage areas should achieve more than the minimum compliance requirements, which are as follows:

- Ensuring BCA compliance, including ventilation. Where required, ventilation system must comply with AS1668.4-2012 The use of ventilation and air conditioning in buildings.
- Ensuring storage areas are well lit (sensor lighting preferred) and have lighting available 24 hours a day.
- Provision of bin washing facilities, including taps for hot and cold water provided through a centralised mixing valve. The taps must be protected from bins and be located where they can be easily accessed even when the area is at bin capacity.
- Floor constructed of concrete at least 75mm thick.
- Floor graded so that any water is directed to a sewer authority approved drainage connection to ensure washing bins and/or waste storage areas do not discharge flow into the stormwater drain.
- Provision of smooth, cleanable and durable floor and wall surfaces that extend up the wall to a height equivalent to any bins held in the area.
- Ensuring ceilings are finished with a smooth-faced non-absorbent material capable of being cleaned.
- All surfaces (walls, ceiling and floors) finished in a light colour.

12.1 ADDITIONAL CONSIDERATIONS

- Waste room floor to be sealed with a two-pack epoxy;
- All corners coved and sealed 100mm up, this is to eliminate build-up of dirt;
- Tap height and light switch height of 1.6m;
- Storm water access preventatives (grate);
- All walls painted with light colour and washable paint;
- Equipment electric outlets to be installed 1700mm above finished floor level;
- Optional automatic odour and pest control system installed
- If 660L or 1100L bins are utilised, 2 x 820mm (minimum) double-doors must be used;
- All personnel doors are hinged, lockable and self-closing;
- Conform to the Building Code of Australia, Australian standards and local laws; and
- Childproofing and public/operator safety shall be assessed and ensured
- Waste and recycling rooms must have their own exhaust ventilation system either;
 - Mechanically - exhausting at a rate of 5L/m² floor area, with a minimum rate of 100L/s minimum. Mechanical exhaust systems shall comply with AS1668.4.2012 and not cause any inconvenience, noise or odour problem; or
 - Naturally - permanent, unobstructed, and opening direct to the external air, not less than one-twentieth (1/20) of the floor area.

13.0 USEFUL CONTACTS

EFC does not warrant or make representation for goods or services provided by suppliers.

PRIVATE WASTE COLLECTION PROVIDER

Capital City Waste Services	Ph: 02 9599 9999	E: service@ccws.net.au
Remondis	Ph: 02 9032 7100	
Suez Environmental	Ph: 13 13 35	
Wastewise NSW	Ph: 1300 550 408	E: admin@wastewise.com.au

BIN MOVING DEVICE SUPPLIERS

Electrodrive	Ph: 1800 333 002	E: sales@electrodrive.com.au
Sitecraft	Ph: 1300 363 152	E: sales@sitecraft.com.au
Spacepac	Ph: 1300 763 444	

ORGANIC DIGESTERS AND DEHYDRATORS

Closed Loop	Ph: 1300 762 166	
Orca		E: contact.australia@feedtheorca.com
Soil Food	Ph: 1300 556 628	
Waste Master	Ph: 1800 614 272	E: hello@wastemasterpacific.com.au

COOKING OIL CONTAINERS AND DISPOSAL

Auscol	Ph: 1800 629 476	E: sales@auscol.com
--------	------------------	---

ODOUR CONTROL

EF Neutralizer	Ph: 1300 435 374	E: info@elephantsfoot.com.au
----------------	------------------	---

SOURCE SPERATION BINS

Source Separation Systems	Ph: 1300 739 913	E: info@sourceseparationsystems.com.au
---------------------------	------------------	---

MOBILE GARBAGE BINS, BULK BINS AND BIN EQUIPMENT

SULO	Ph: 1300 364 388	E: sales@sulo.com.au
OTTO Australia	Ph: 02 9153 6999	

CHUTES, COMPACTORS AND EDIVERTER SYSTEMS

Elephants Foot	Ph: 1800 025 073	E: info@elephantsfoot.com.au
----------------	------------------	---

APPENDIX A: ARCHITECTURAL PLANS

APPENDIX: A.1 LOWER GROUND FLOOR PLAN – WASTE AREAS

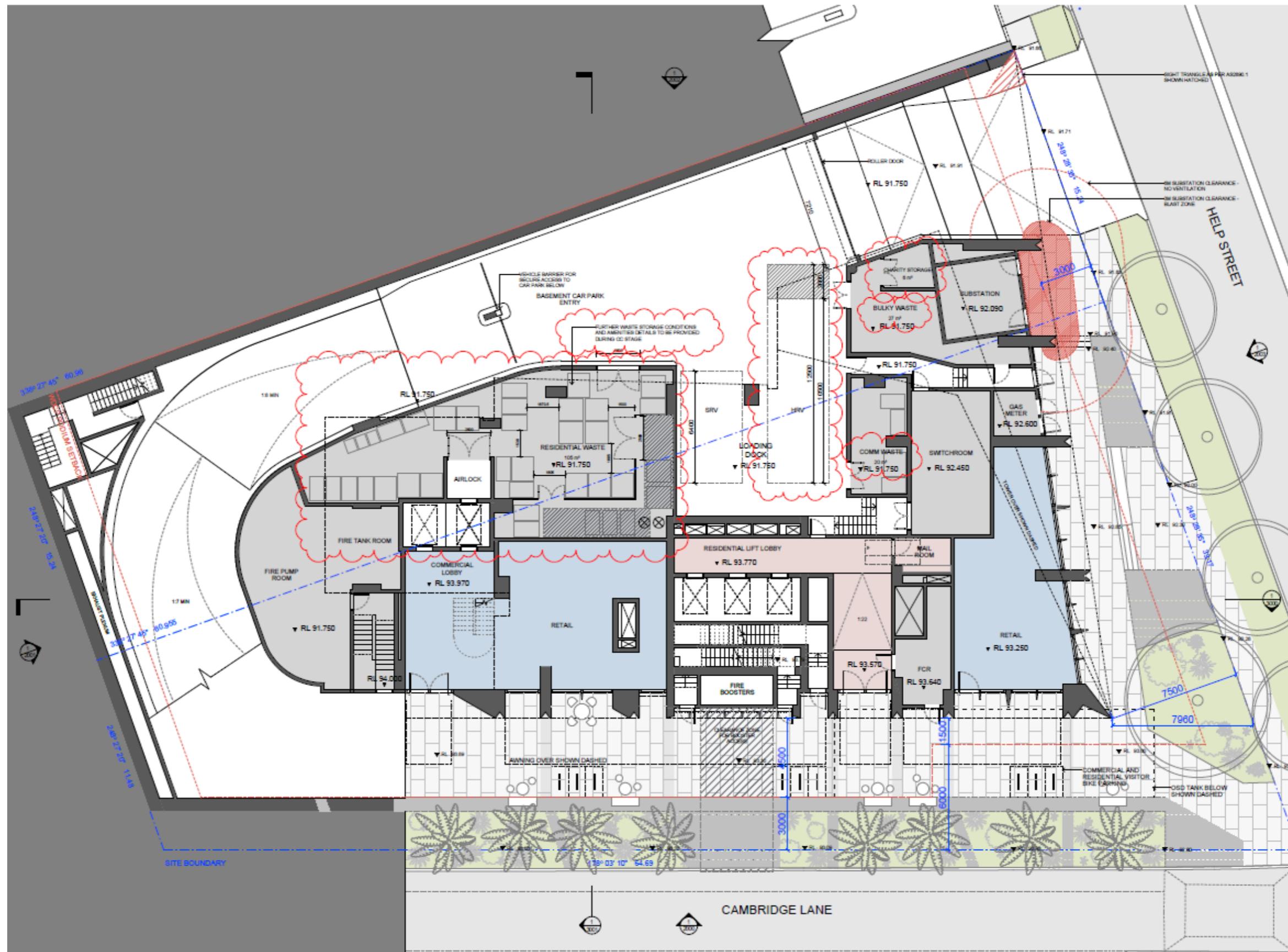

Source: Embece, Drawing 1010, Rev D, Aug2025 – LG Plan

APPENDIX B: INSTALLATION EQUIPMENT

APPENDIX: B.1 TYPICAL DUAL CHUTE SHAFT & PENETRATION SET-OUT



CHUTE SHAFT & PENETRATION SET-OUT
DUAL Ø610 STEEL

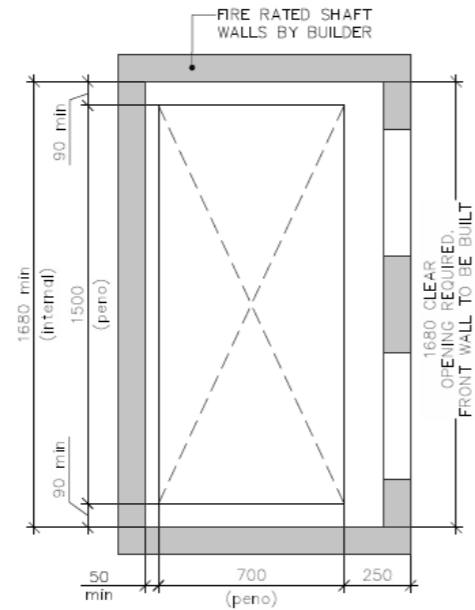

01 DUAL (610Ø) GALV. STEEL CHUTE LAYOUT PENETRATION SET-OUT

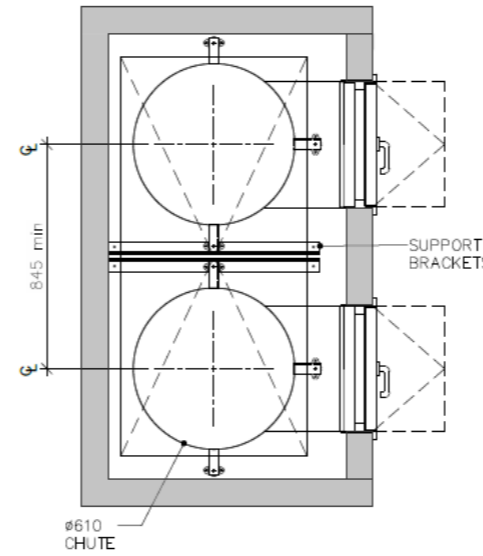

02 DUAL (610Ø) GALV. STEEL CHUTE LAYOUT

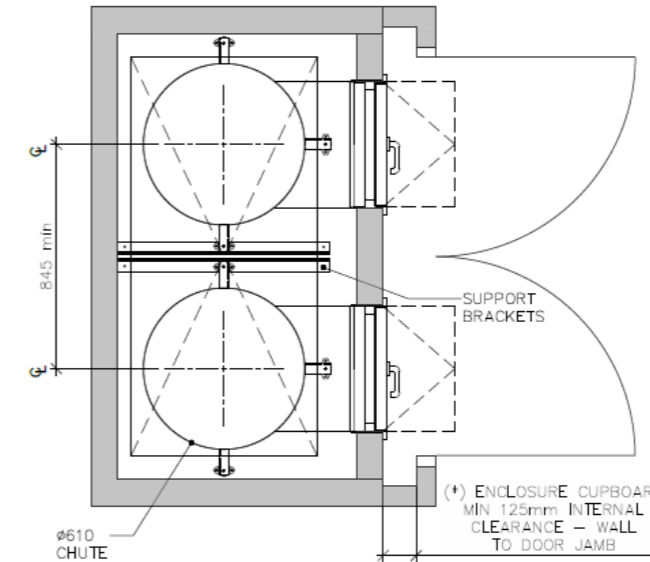

03 DUAL (610Ø) GALV. STEEL CHUTE LAYOUT with ENCLOSURE CUPBOARD (*)

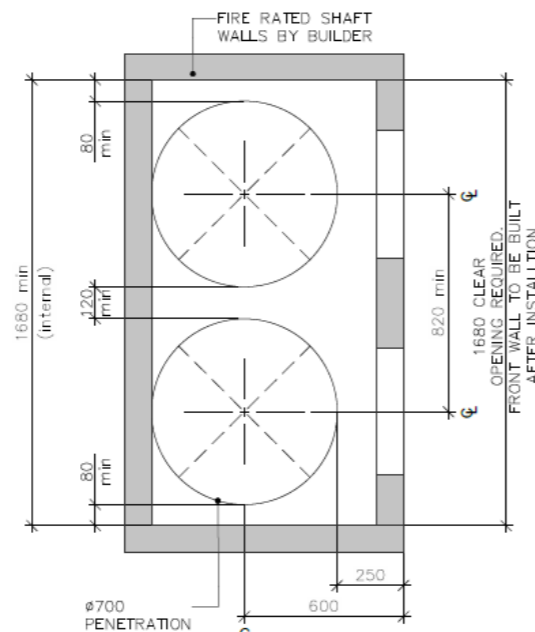

04 DUAL (610Ø) GALV. STEEL CHUTE LAYOUT WITH CIRCULAR PENETRATION SET-OUT

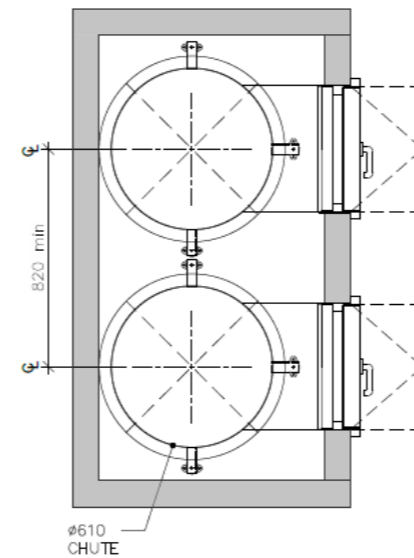

05 DUAL (610Ø) GALV. STEEL CHUTE LAYOUT (W/ CIRCULAR PENETRATION)

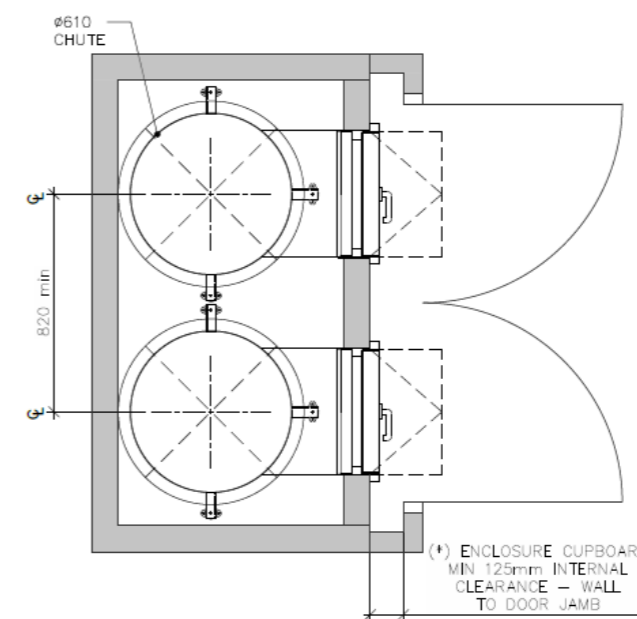

06 DUAL (610Ø) GALV. STEEL CHUTE LAYOUT with ENCLOSURE CUPBOARD (*)

(*) NOTE: ENCLOSURES ARE RECOMMENDED IF THE CHUTE OPENS DIRECTLY TO A CORRIDOR OR IS NOT LOCATED IN A WASTE ROOM. IF CHUTE ACCESS IS WITHIN A WASTE ROOM THEN THE CUPBOARD ENCLOSURES ARE NOT REQUIRED.

SCALE 1:25 @ A3

Please Note: This is an example only – please refer to supplier's information and specification.

APPENDIX: B.2 TYPICAL LINEAR TRACK SYSTEM FOR 660L BINS

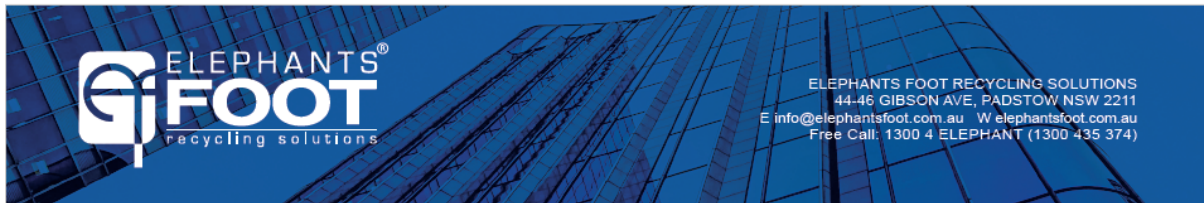

660 LITRE LINEAR TRACK SYSTEM

PRODUCT INFORMATION

Elephants Foot 660 Litre bin Linear Track System is a versatile waste handling solution for many types of multi-storey or multi-level developments. The Linear Track System collects waste or recycling being disposed from the floors above through the chute system, discharging the material via a hopper that feeds the bins. Electromechanically driven with automated operation, the system utilises linear motion to automatically change over full bins. Once all the bins are filled, an indicator light will illuminate signifying that the bins are ready for withdrawal and collection. Available with or without compaction unit, our standard 660 litre bin Linear Track System is available in standard 2 or 3. Our 4 Bin option is available as a special order.



SPECIFICATIONS

System Control	Electric PLC
Power Supply	415 V AC / 10A / 5 PIN
Motor Size (kW)	0.55
Maximum bin load	265 kg
Noise (dBA)	<85
Bin Size (L)	660
Cycle time (sec)	60
Bin Quantity options	2, 3, or 4

OPTIONAL EXTRAS

- Compaction unit – Please refer to the bin compactor product information sheet for details and specifications
- Enhanced safety add on's – Interlocking barriers, occupancy sensors or safety light curtains (presence sensing light barriers)
- Full bin SMS and email notification
- CMMS and BMS integration
- Extend warranty – Terms and conditions apply

STANDARD FEATURES & BENEFITS

- Simple operation with user friendly controls
- Increased waste servicing efficiency for the development
- Automatic system control with manual override
- Robust unit construction for long performance life
- Low service and maintain costs
- Rotating flashing beacon (activated during operation)
- Quiet and efficient system operation
- Maximise safety for residents, caretakers and collectors
- Restrained design with minimal moving parts
- Can suit low ceiling clearances
- Floor contact components fully galvanised steel
- Retro fitting options to suit other chutes systems
- Compliant with relevant Building Codes and Standards
- Standard 12 month warranty



660 LITRE LINEAR TRACK SYSTEM

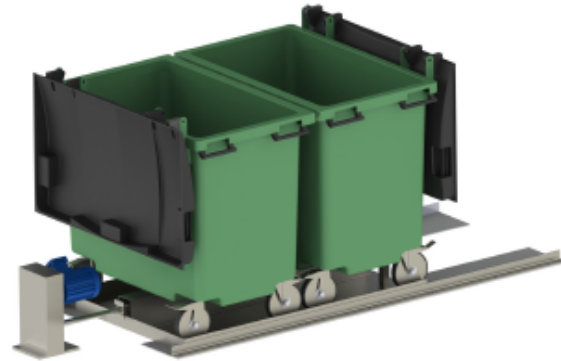

No. of Bins	Reference (mm)		
	A	B	C
2	500	2950	4350
3	1450	4850	6050
4	2300	6300	7750

Available with or without compaction unit, our standard 240 litre bin Linear Track System can support 2, 3 or 4 bin quantities.

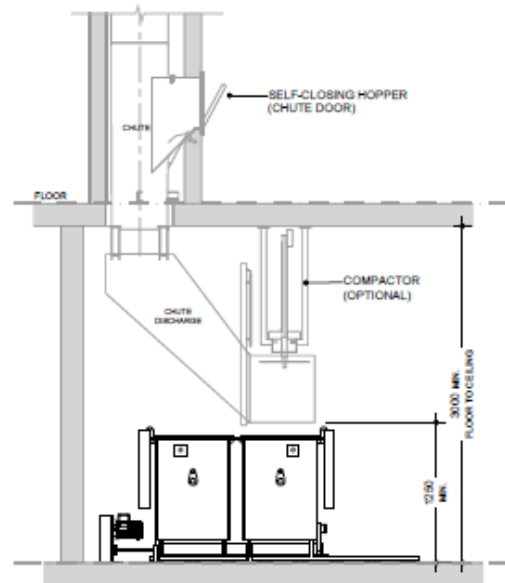
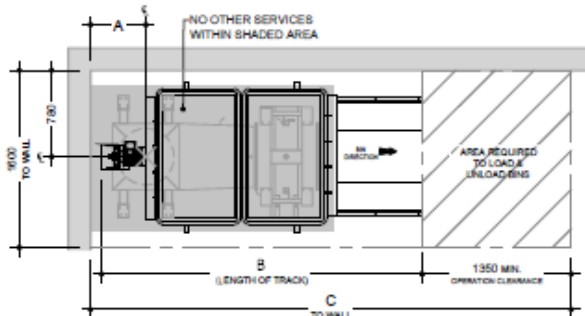

Notes:
Bins not provided by Elephants Foot

Drawings shown are for general information purposes only and provide minimum equipment spacial requirements for waste room design.

These drawings are not intended for site specific use or for construction. Each project is unique and will be designed to suit.

Additional equipment options, systems and configurations are available. For design assessment, information and advice, please contact an Elephants Foot design consultant on 1300 435 374

Please Note: This is an example only – please refer to supplier's information and specification

APPENDIX: B.3 TYPICAL LINEAR TRACK SYSTEM FOR 1100L BINS



1100 LITRE LINEAR TRACK SYSTEM

PRODUCT INFORMATION

Elephants Foot 1100 Litre bin Linear Track System is a versatile waste handling solution for many types of multi-storey or multi-level developments. The Linear Track System collects waste or recycling being disposed from the floors above through the chute system, discharging the material via a hopper that feeds the bins. Electromechanically driven with automated operation, the system utilises linear motion to automatically change over full bins. Once all the bins are filled, an indicator light will illuminate signifying that the bins are ready for withdrawal and collection. Available with or without compaction unit, our standard 660 litre bin Linear Track System is available in the standard 2 bin option. Our 3 Bin option is available as a special order.



SPECIFICATIONS

System Control	Electric PLC
Power Supply	415 V AC / 10A / 5 PIN
Motor Size (kW)	1.1
Maximum bin load	440 kg
Noise (dBA)	<85
Bin Size (L)	1100
Cycle time (sec)	60
Bin Quantity options	2 or 3

OPTIONAL EXTRAS

- Compaction unit – Please refer to the bin compactor product information sheet for details and specifications
- Enhanced safety add on's – Interlocking barriers, occupancy sensors or safety light curtains (presence sensing light barriers)
- Full bin SMS and email notification
- CMMS and BMS integration
- Extend warranty – Terms and conditions apply

STANDARD FEATURES & BENEFITS

- Simple operation with user friendly controls
- Increased waste servicing efficiency for the development.
- Automatic system control with manual override
- Robust unit construction for long performance life
- Low service and maintain costs
- Rotating flashing beacon (activated during operation)
- Quiet and efficient system operation
- Maximise safety for residents, caretakers and collectors
- Restrained design with minimal moving parts
- Can suit low ceiling clearances
- Floor contact components fully galvanised steel
- Retro fitting options to suit other chutes systems
- Compliant with relevant Building Codes and Standards
- Standard 12 month warranty

1,100 LITRE LINEAR TRACK SYSTEM



No. of Bins	Reference (mm)		
	A	B	C
2	900	3700	5300
3	2100	5940	7550

Available with or without compaction unit, our standard 1100 litre bin Linear Track System is available in the standard 2 bin option. Our 3 Bin option is available as a special order.

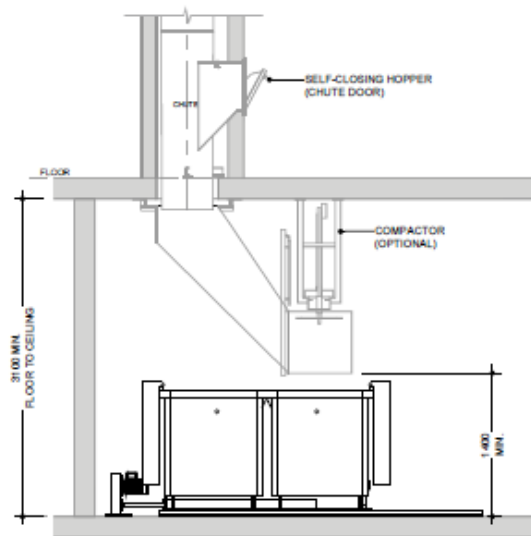
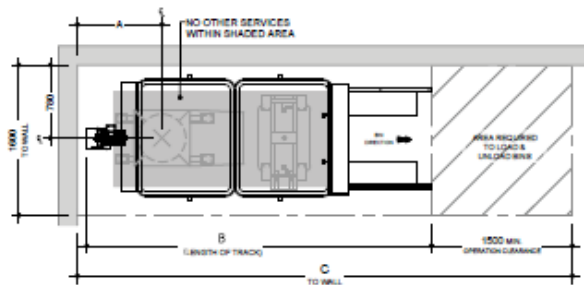

Notes:
 Bins not provided by Elephants Foot

Drawings shown are for general information purposes only and provide minimum equipment spacial requirements for waste room design.

These drawings are not intended for site specific use or for construction. Each project is unique and will be designed to suit.

Additional equipment options, systems and configurations are available. For design assessment, information and advice, please contact an Elephants Foot design consultant on 1300 435 374

Please Note: This is an example only – please refer to supplier's information and specification

APPENDIX C: PRIMARY WASTE MANAGEMENT PROVISIONS

APPENDIX: C.1 TYPICAL BIN SPECIFICATIONS

Mobile bins

Mobile bins come in a variety of sizes and are designed for lifting and emptying by purpose-built equipment.

Mobile bins with capacities of up to 1700L must comply with *AS4123.6-2006 Mobile waste containers* which specifies standard sizes and sets out the colour designations for the bodies and lids of mobile waste containers indicating the type of materials they are used to collect.

The most common bin sizes are provided below, although not all sizes are shown. The dimensions are a guide only and differ slightly between manufacturers. Some bins have flat or domed lids and are used with different lifting devices. Refer to *AS4123.6-2006* for further details.

Table G1.1: Average dimension ranges for two-wheel mobile bins



Bin capacity	80L	120L	140L	240L	360L
Height (mm)	870	940	1065	1080	1100
Depth (mm)	530	530	540	735	820
Width (mm)	450	485	500	580	600
Approximate footprint (m ²)	0.24	0.26–0.33	0.27-0.33	0.41–0.43	0.49
Approximate weight (kg)	8.5	9.5	10.4	15.5	23
Approximate maximum load (kg)	32	48	56	96	Not known

Wheelie bin

Sources include Sulo, Single Waste, Cleanaway, SUEZ, just wheelie bins and Perth Waste for two-wheel mobile bins

Table G1.2: Average dimension ranges for four-wheel bulk bins



Bin capacity	660L	770L	1100L	1300L	1700L
Height (mm)	1250	1425	1470	1480	1470
Depth (mm)	850	1100	1245	1250	1250
Width (mm)	1370	1370	1370	1770	1770
Approx footprint (m ²)	0.86–1.16	1.51	1.33–1.74	2.21	2.21
Approx weight (kg)	45	Not known	65	Not known	Not known
Approx maximum load (kg)	310	Not known	440	Not known	Not known

Dome or flat lid container

Sources include Sulo, Signal Waste, Cleanaway, SUEZ, Just Wheelie Bins and Perth Waste

Source: *Better Practice Guide For Resource Recovery In Residential Developments 2019, NSW Environmental Protection Authority*

APPENDIX: C.2 SIGNAGE FOR WASTE AND RECYCLING BINS

Waste signs

Signs and educational materials perform several functions including:

- informing residents why it is important to recover resources and protect the environment
- providing clear instructions on how to use the bins and services provided
- alerting people to any dangers or hazards within the bin storage areas.

All waste, recycling and organic bins should be Australian Standard colours and clearly and correctly labelled, such as by a sticker on the lid and/or the body of the bin.

Communal bin storage areas should be clearly signposted with signs outlining how to correctly separate waste into the bins provided. The local council responsible for waste services may be a good source of signs and posters and can advise on what signs are suitable.

Information on who to contact to find out more about the recycling and/or other resource recovery services in the building should also be displayed in communal areas, such as on a noticeboard.

The Planet Ark website also has resources available free of charge for use by businesses and councils. These signs can be found at businessrecycling.com.au/research/signage.cfm

Figure I1.1: Examples of waste wall posters (EPA supplied)



Figure I1.2: Examples of bin lid stickers (EPA supplied)



Source: *Better Practice Guide For Resource Recovery In Residential Developments 2019*, NSW Environmental Protection Authority

Problem waste signs

The EPA has also produced a range of images and signs that can be used for problem wastes, such as fluoro globes and tubes, household and car batteries, e-waste and smoke detectors. To access these resources, contact the NSW EPA. Some examples are shown below.

Figure I2.1: Problem waste signs



Safety signs

The use of safety signs for waste resource recovery rooms must comply with *AS1319 Safety signs for occupational environments*. Safety signs must be used to regulate and control safety related to behaviour, warn of hazards and provide emergency information, including fire protection information. Suitable signs should be decided for each development as required.

Figure I3.1: Example safety signs



Source: *Better Practice Guide For Resource Recovery In Residential Developments 2019*, NSW Environmental Protection Authority

APPENDIX: C.3 TYPICAL COLLECTION VEHICLE INFORMATION

General

Appropriate heavy rigid vehicle standards should be incorporated into the road and street designs in new developments where onsite collections are proposed. Road and street designs must comply with relevant Acts, regulations, guidelines, and codes administered by Austroads, Standards Australia, NSW Roads and Maritime Services, WorkSafe NSW and any local council traffic requirements.

Applicants and building designers should consult with councils and other relevant authorities before designing new roads or streets and access points for waste collection vehicles to establish specific design requirements.

Table H4.1: Australian Standards for turning circles for medium and heavy rigid class vehicles

Vehicle class	Overall length (m)	Design width (m)	Design turning radius (m)	Swept circle (m)	Clearance (travel) height (m)
Medium rigid vehicle	8.80	2.5	10.0	21.6	4.5
Heavy rigid vehicle	12.5	2.5	12.5	27.8	4.5

Large collection vehicles

Waste collection vehicles may be side-loading, rear-loading, front-lift-loading, hook or crane lift trucks. Vehicle dimensions vary by collection service, manufacturer, make and model. It is not possible to provide definitive dimensions, so architects and developers should consult with the local council and/or contractors.

The following characteristics represent typical collection vehicles and are provided for guidance only. Reference to *AS2890.2 Parking facilities: off-street commercial vehicle facilities* for detailed requirements, including vehicle dimensions, is recommended.

Table B2.1: Collection vehicle dimensions

Vehicle type	Rear-loading	Side-loading*	Front-lift-loading	Hook truck	Crane truck
Length overall (m)	10.5	9.6	11.8	10.0	10.0
Width overall (m)	2.5	2.5	2.5	3.0	2.5
Travel height (m)	3.9	3.6	4.8	4.7	3.8
Operational height for loading (m)	3.9	4.2	6.5	3.0	8.75
Vehicle tare weight (t)	13.1	11.8	16.7	13.0	13.0
Maximum payload (t)	10.0	10.8	11.0	14.5	9.5
Turning circle (m)	25.0	21.4	25.0	25.0	18

* The maximum reach of a side arm is 3 m.

Sources: JJ Richards, SUEZ, MacDonald Johnson, Cleanaway, Garwood, Ros Roca, Bingo and Edbro. Figures shown represent the maximum dimensions for each vehicle type.

Rear-loading collection vehicles

These vehicles are commonly used for domestic waste collections from MUDs and RFBs and sometimes for recycling. They can be used to collect waste stored in mobile bins or bulk bins, particularly where bins are not presented at the kerbside. They are also used for collecting bulky waste.

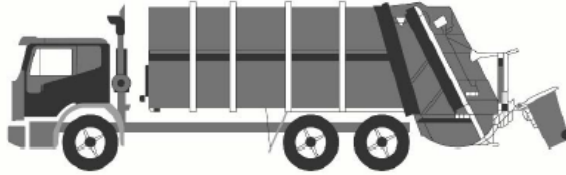

Rear-loading waste collection vehicle

Side-loading collection vehicles

This is the most commonly used vehicle for domestic waste, recycling and organics collections. It is only suitable for collecting mobile bins up to 360L in capacity.

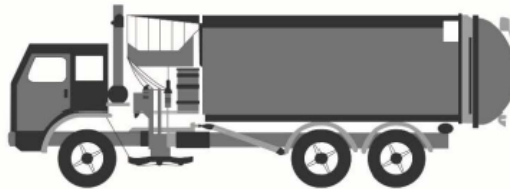

Side-loading waste collection vehicle

Front-lift-loading collection vehicles

These vehicles are commonly used for collecting commercial and industrial waste. They can only collect specially designed front-lift bulk bins and not mobile bins.



Front-lift-loading waste collection vehicle

Small collection vehicles

Typically, councils and their contractors operate with large collection vehicles (heavy rigid class vehicles) because they carry greater payloads and allow for more cost-effective collection services. Some councils, or their contractors, may have smaller collection vehicles in their fleet. Early discussion with the council is important to confirm this, but it should not be assumed that the council will have access to small collection vehicles.

The waste management systems and the location of the collection point should always be designed so that the council can provide the standard domestic waste service.

Source: *Better Practice Guide For Resource Recovery In Residential Developments 2019*, NSW Environmental Protection Authority

Source: *Better Practice Guide For Resource Recovery In Residential Developments 2019*, NSW Environmental Protection Authority

APPENDIX: C.4 TYPICAL BIN MOVERS

Battery powered tug with a 1 or 2 tonne tow capacity



Features at a glance

One tonne (Evo 1T) or two tonne (Evo 2T) tow capacity

Auto latching hitch

Three speed motor with emergency stop

Typical applications

The Tug Evo is suitable for airports, factories, warehouses, apartment buildings or large facilities. This powered tug is also suitable for transporting medical carts around hospitals or moving heavy specialist equipment.

Features:

- 1 or 2 tonne tow capacity of inclines up to 6 degrees
- 500kg tow capacity if inclines up to 14 degrees
- CE Compliant
- 5 km/h max speed
- 2 x 12V 42Ah MK-gel batteries with 24V smart charger.
- Powerful transaxle

Safety Features:

- Intuitive control with standard automatic safety brake, forward and reverse drive.
- Emergency stop button.

Emergency back-off button

Source: <http://www.electrodrive.com.au/products/tugs/tug-evo.aspx>

APPENDIX: C.5 TYPICAL SEATED BIN MOVERS

SITECRAFT



MATERIALS HANDLING EQUIPMENT

17 Macquarie Drive, Thomastown, VIC 3074
 Phone: 1300 363 152 Fax: 1300 722 383
 E: sales@sitecraft.com.au ABN: 36 423 328 526

SITECRAFT HEAVY DUTY ELECTRIC TOW TRACTOR

- > Towing capacities from 2000 kg to 6,000 kg
- > **Full AC electric system** has a brake-releasing function, making the unit easy and effortless to operate; The maintenance-free motor completely solves the issues of DC motor carbon brush.
- > Batteries located in the lowest part of frame ensures excellent stability
- > Quick open back service cover for easy maintenance and part replacement
- > CANbus technology reduces wiring complexity and increases reliability
- > H type axle design provides excellent stability
- > New high-range steering design; light steering and easy to maintain.
- > New large-screen instrument display provides information clearly and directly to the operator.



**12 MONTH
WARRANTY**

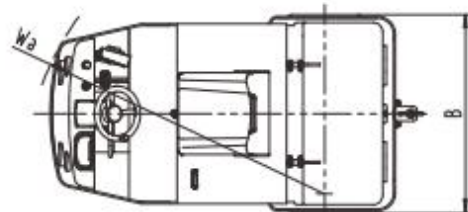
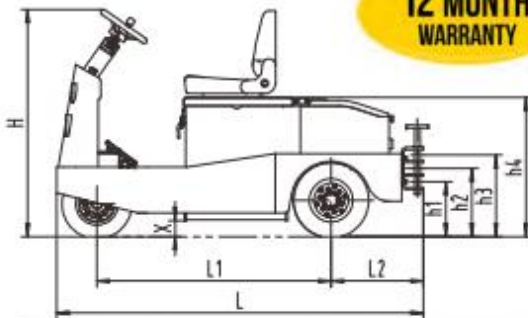

Model		ST-2000AC	ST-3000AC	ST-5000AC	ST-6000AC
Towing Capacity	Kg	2000	3000	5000	6000
Drawbar Centre Height	h1/h2/h3 mm	280/350/420	280/350/420	280/350/420	280/350/420
Motor	Kw / V	3Kw / 36V	3Kw / 36V	5Kw / 48V	5Kw / 48V
Total Size	L x B x H mm	1720 x 968 x 1270	1720 x 968 x 1270	1975 x 1100 x 1270	1975 x 1100 x 1270
Total Weight (With Batteries)	Kg	740	780	1240	1280
Wheel Size	Solid Rubber	15*4-8	15*4-8	15*4-8	15*4-8
Wheelbase	L1 mm	1055	1055	1280	1280
Rear Hanging Distance	L2 mm	382	382	500	500
Seat Height	h4 mm	910	910	910	910
Ground Clearance	X mm	90	90	90	90
Turning Radius	Wa mm	1500	1500	1650	1650
Maximum Speed	Km/h	10	8	14	12
Battery	V/Ah	36/200	36/250	48/360	48/400
Battery Weight	Kg	200	250	610	650
Charger	On-board V/Ah	36/30	36/30	48/50	48/50

SITECRAFT

MATERIALS HANDLING EQUIPMENT



17 Macquarie Drive, Thomastown, VIC 3074
 Phone: 1300 363 152 Fax: 1300 722 383
 E: sales@sitecraft.com.au ABN: 36 423 328 526

SITECRAFT HEAVY DUTY ELECTRIC TOW TRACTOR



Sitecraft ST3000-AC tow tug moving 660 & 1100 litre bins



Sitecraft ST3000-AC tow tug moving 660 & 1100 litre bins

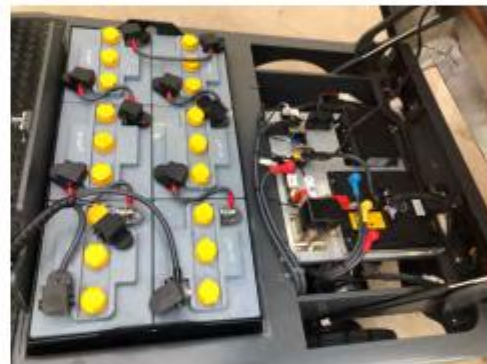

ST3000-AC tow tug complete with 6 x 250AH heavy duty batteries



Optional steel / aluminium trailers for moving waste bins, linen trolleys, food trolleys, delivery boxes, etc ...

Source: <https://www.sitecraft.net.au/materials-handling/tow-tugs-powered-vehicles/electric-tow-vehicles/>

APPENDIX D: SECONDARY WASTE MANAGEMENT PROVISIONS

APPENDIX: D.1 TYPICAL COOKING OIL CONTAINERS



Drums 205L



Pour in Bulk Tank

[View Brochure](#)



Oil Kaddy System

[View Brochure](#)



Eco System 700L fixed Eco System 310L mobile

Eco Systems



Direct-Connect to Fryer

Source: <http://www.auscol.com/services/collection-systems/>