



WIND ENGINEERING
CONSULTANTS

QUALITATIVE WIND ASSESSMENT
CPP PROJECT 20106
13 NOVEMBER 2024

Hammond Greens

5-9 Gordon Ave, Chatswood, NSW

CPP Wind Engineering
Consultants

2/500 Princes Highway
St Peters NSW 2044

Info-syd@cppwind.com

cppwind.com

PREPARED FOR:

Mainway
Lvl 5, Suite 10, 157 Gloucester St
The Rocks, NSW, 2000

James Lim
0422 745 236
Senior Project Manager

PREPARED BY:

Jordan Black
Project Engineer
jblack@cppwind.com

Joe Paetzold, PhD
Engineering Manager
jpaetzold@cppwind.com

Executive Summary

A qualitative assessment of the Hammond Greens development to be built at 5-9 Gordon Ave, Chatswood, NSW was conducted to provide an initial assessment of the surrounding pedestrian wind environment. The assessment was based on the local wind climate, CPP's experience in the region and on comparable projects, and the characteristics of the proposed development.

The wind environment around the development is likely to be generally suitable for Pedestrian Walking style activities from a comfort perspective with reference to the Lawson criteria. No major adverse impacts to pedestrian comfort or amenity are foreseen as a result of the proposed development. Areas intended for long term stationary activity such as seating and dining will likely require treatment to ensure they are suitable for their intended use. Most areas in the public domain in the vicinity of the subject site are expected to satisfy the relevant wind safety criterion.

Wind conditions on most residential balconies are expected to be generally mild and typical of or better than comparable buildings in the region. Reasonably windy conditions are expected to occur on parts of the podium terrace at times, and recommendations for improving the wind amenity of this area have been provided. Most areas on the private rooftop terrace are expected to be relatively mild. The requirements for mitigating stronger wind conditions will depend on the intended use of these areas.

This report is a high-level qualitative assessment based on basic features of the local wind climate and proposed built environment.

Document Tracking and Version Control

REVISION	RELEVANT INFORMATION
R00	Date Issued: 2/05/2023
	Prepared by: NM
	Reviewed by: JP
	Approved by: JP
	Document Name: CPP16736_5 Gordon Avenue_REP_DS_PW_R00D00.pdf
R01	Date Issued: 19/05/2023
	Prepared by: TE
	Reviewed by: JP
	Approved by: JP
	Document Name: CPP16736_5 Gordon Avenue_REP_DS_PW_R01.pdf
R02	Date Issued: 23/05/2024
	Prepared by: Jordan Black
	Reviewed by: Joe Paetzold
	Approved by: Joe Paetzold
	Document Name: CPP20106_Hammond Greens_REP_DS_PW_R02.pdf
R03	Date Issued: 4/11/2024
	Prepared by: Jordan Black
	Reviewed by: Joe Paetzold
	Approved by: Joe Paetzold
	Document Name: CPP20106_Hammond Greens_REP_DS_PW_R03.pdf
R04	Date Issued: 13/11/2024
	Prepared by: Jordan Black



Reviewed by: Joe Paetzold

Approved by: Joe Paetzold

Document Name: CPP20106_Hammond Greens_REP_DS_PW_R04.pdf

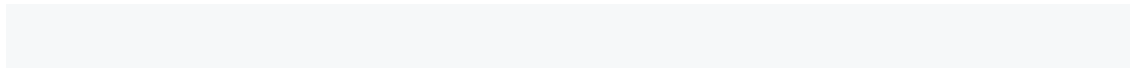

Contents

Executive Summary	1
Document Tracking and Version Control	3
1. Introduction	6
General information	6
2. Wind Climate	8
3. Wind Assessment Criteria	9
3. Assessment	11
Site Description	11
Winds from the North-East	13
Winds from the South	14
Winds from the West	16
Summary – Public Domain	16
Wind conditions within the development	17
4. Conclusion	19
References	20
Appendix A – Wind Flow Mechanisms	21
Appendix B - Wind Impact Planning Guidelines	23

1. Introduction

GENERAL INFORMATION

The assessment of the wind environment around developments can ensure adverse impacts are minimised and inform designers about the suitability of outdoor areas for their intended uses. Where necessary, design modifications can be made, or intervention measures added to mitigate areas with the potential for excessive wind speeds.

The proposed development is located in 5-9 Gordon Ave, Chatswood, approximately 600 meters south of the Chatswood CBD. The surrounding terrain is comprised primarily of low-rise suburban development as shown in Figure 1.

The proposed development is comprised of a single prismatic tower set back over a podium, reaching a maximum height of about 115 m above ground level, Figure 2. As it is significantly larger than most of the surrounding structures, the addition of the proposed development is expected to have some impact on the local wind conditions, and the extents are broadly discussed in this report.

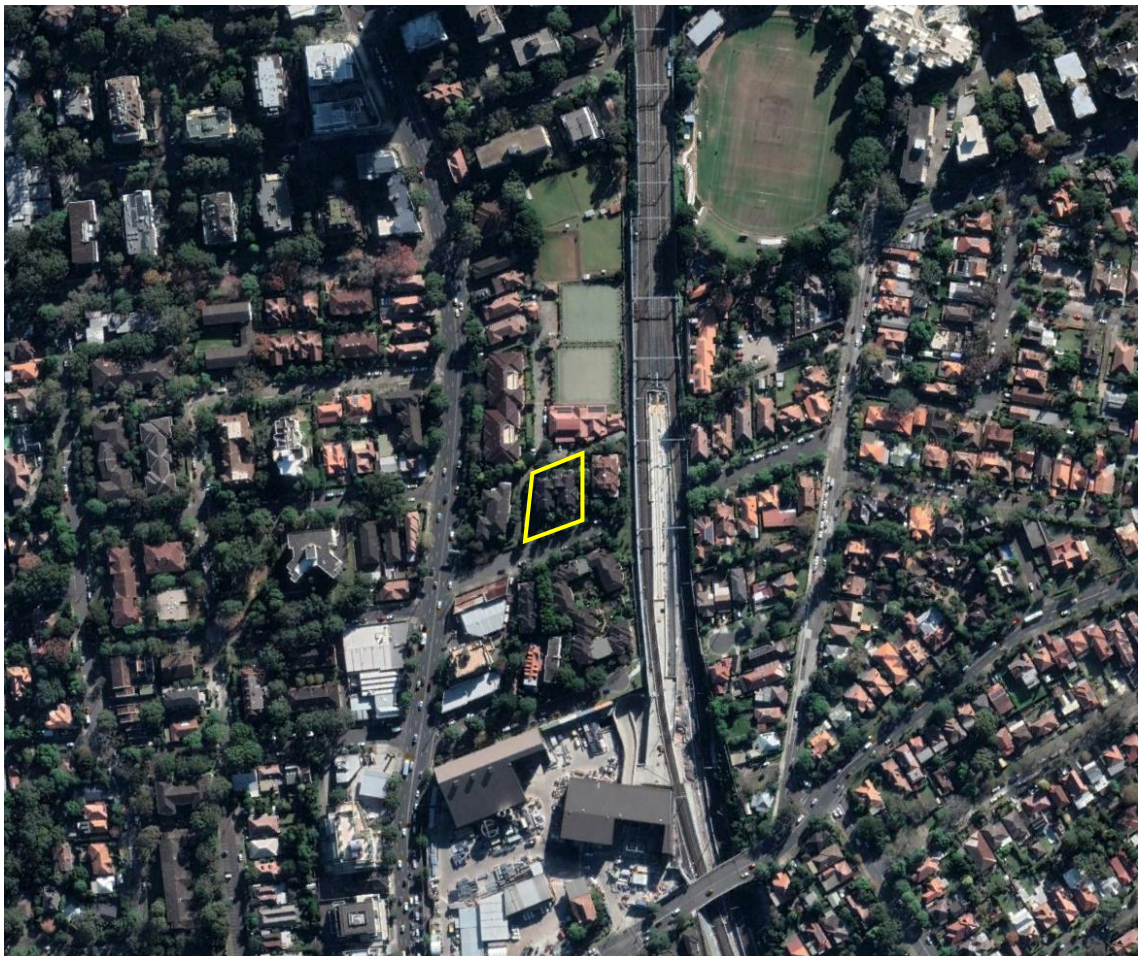

Figure 1: Aerial view of proposed development site (Google Earth, 2023)

2. Wind Climate

The proposed development lies approximately 16 km to the north of the Sydney Airport Bureau of Meteorology anemometer, which provides the best source of historical wind data for the project. To enable a qualitative assessment of the wind environment, the wind frequency and direction information measured by the Bureau of Meteorology at a standard height of 10 m from 1995 – 2021 have been used in this analysis.

The wind rose for Sydney Airport is shown in Figure 3. The arms of the wind roses point in the direction from where the wind is blowing, the width and colour of the arm represent the wind speed, and the length of the arm indicates the percent of the time that the wind blows for that combination of speed and direction.

The distribution and frequency of winds on an annual basis were analysed to assess the project with regards to wind comfort and safety. As can be seen from the wind rose in Figure 3, winds from the west, north-east and south directions are predominant. This wind assessment is structured around these prevailing wind directions.

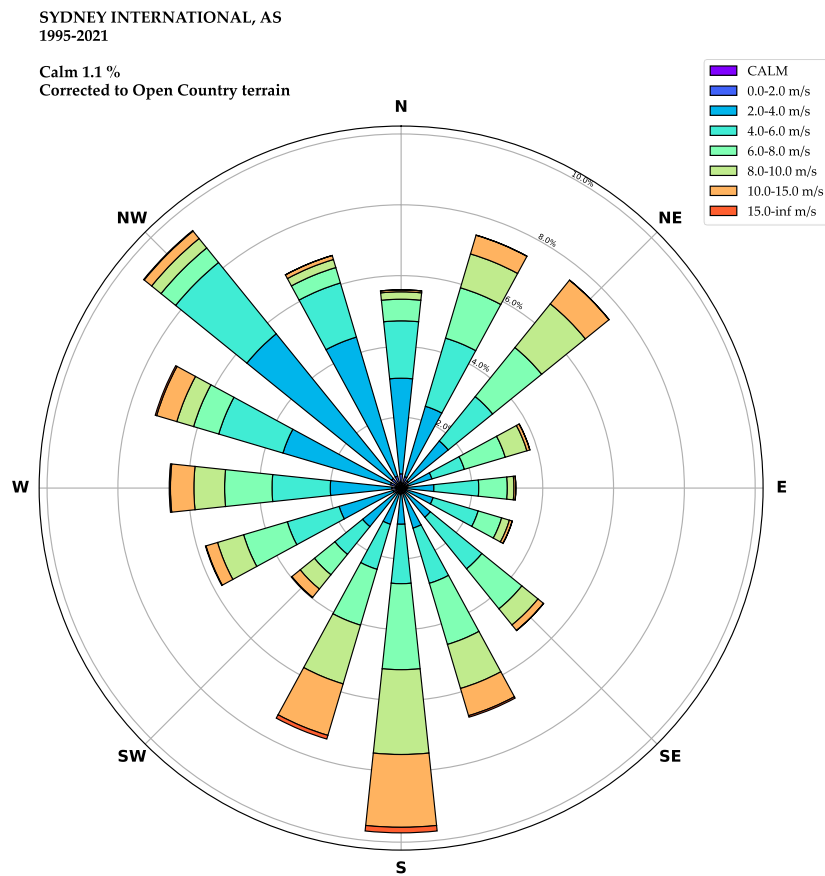

Figure 3: Probability of Wind Speeds by Direction Sydney Airport – 1995 – 2021, All Hours)

3. Wind Assessment Criteria

A number of researchers have suggested quantitative methods for assessing wind comfort and safety based on estimated wind speeds and local climate statistics. These criteria provide a means of evaluating the wind amenity of location based on the frequency of threshold wind speeds, noting that pedestrians will tolerate higher wind speeds for a shorter time period than lower speeds. The comfort criteria also allow planners to assess the usability, with respect to the wind environment, of different locations for various purposes.

The Willoughby City Council DCP (2016) does not specify a method of assessing wind comfort or safety for this site. CPP uses a modified form of the widely-accepted pedestrian-level wind criteria developed by Lawson (1990). Lawson's criteria are divided into separate categories of comfort and distress (safety).







Lawson's criteria are based on wind speeds exceeded 5% of the time, and are described as categories for comfort ranging from 'Pedestrian Sitting' to 'Business Walking', allowing planners to judge the usability of locations for various intended purposes. The criteria also include a distress rating, for safety assessment, which is based on occasional (once or twice per year) wind speeds, to identify locations where wind speeds may be hazardous to pedestrians.

The categories and criteria are specified in Table 1. In general, wind conditions comfortable for Sitting and Standing are considered appropriate for areas such as entrances where pedestrians are likely to gather for longer durations, while wind conditions comfortable for Pedestrian Walking and Business Walking are more appropriate for sidewalks where pedestrians are actively in transit. Locations rated as Uncomfortable are generally less suitable for most pedestrian activities and wind control solutions are often sought. Whether mitigation is needed at a location depends upon the intended pedestrian use of the location.

Satisfaction of the safety rating is generally required for areas accessible to the general public. A rating of 'Able-Bodied' may be acceptable for areas with managed access or where pedestrians are unlikely to be present under adverse conditions.

Pedestrians' perception of wind can often be subjective and vary depending on regional difference in wind climate and thermal conditions, as well as by individual. Calibration to the local wind environment should be taken into account when evaluating predicted wind comfort conditions. Note that the ratings of 'Uncomfortable' and 'Safety' are the words of the published wind criteria and applicability may vary by project and location.



Table 1: Wind Comfort and Safety criteria (after Lawson, 1990)

COMFORT RATING	U _{EQUIV} *	DESCRIPTION
 Dining**	< 2 m/s	Calm / light breezes suitable for outdoor restaurant uses, seating areas, and other amenities based on CPP experience.
 Sitting	2-4 m/s	Calm or light breezes suitable for long duration seating areas, and other amenities.
 Standing	4-6 m/s	Gentle breezes suitable for sitting for shorter periods, main entrances and bus stops where pedestrians may linger.
 Pedestrian Walking	6-8 m/s	Moderate winds appropriate for window shopping and strolling along a downtown street, or park.
 Business Walking	8-10 m/s	Relatively high speeds that can be tolerated if one's objective is to walk, run, or cycle.
 Uncomfortable	> 10 m/s	Strong winds unacceptable for all pedestrian activities; wind mitigation is typically required.

*U_{Equiv} = Max (U_{Mean}, U_{Gust} / 1.85).

*U_{Equiv} speeds are based on an annual exceedance of 5% (~8 hours / week) assessed over all hours.

** For regular outdoor dining, and in semi-enclosed spaces, it has been the experience of CPP that the comfort rating of Sitting may be windier than desired and a comfort criterion of 2 m/s or less may be more applicable.

SAFETY RATING	U _{EQUIV} *	DESCRIPTION
 Pass	< 15 m/s	Meets wind safety criterion.
 Able-Bodied	15-20 m/s	Acceptable where only able-bodied people would be expected; not acceptable for frail persons or cyclists
 Fail	>20 m/s	Excessive wind speeds that can adversely affect a pedestrian's balance and footing. Wind mitigation is often required.

* U_{Equiv} = Max (U_{Mean}, U_{Gust} / 1.85).

*U_{Equiv} speeds are based on an annual exceedance of 0.022% (~2 / year or 1 / season) assessed over all hours.

3. Assessment

SITE DESCRIPTION

The development site is surrounded in most directions by low-rise buildings, with Chatswood Oval to the north-east. Directly north of the site is Chatswood Bowling Club and greens. Topography surrounding the site is relatively flat in most directions with a slight increase in terrain for from the west when approaching the site. Winds in such surrounds tend to experience less channelling than areas with many tall structures, with local effects instead being dictated by exposed buildings and their relation to prevailing strong wind directions. Several wind flow mechanisms such as downwash and channelling flow are described in Appendix A and the effectiveness of some common wind mitigation measures are described in Appendix B.

The subject site is located on a block bounded by Gordon Avenue to the south and Hammond Lane to the west. The proposed development consists of a single prismatic tower with a rectangular planform. A ground floor plan is shown in Figure 4.



Figure 4: Ground floor plan of proposed development.

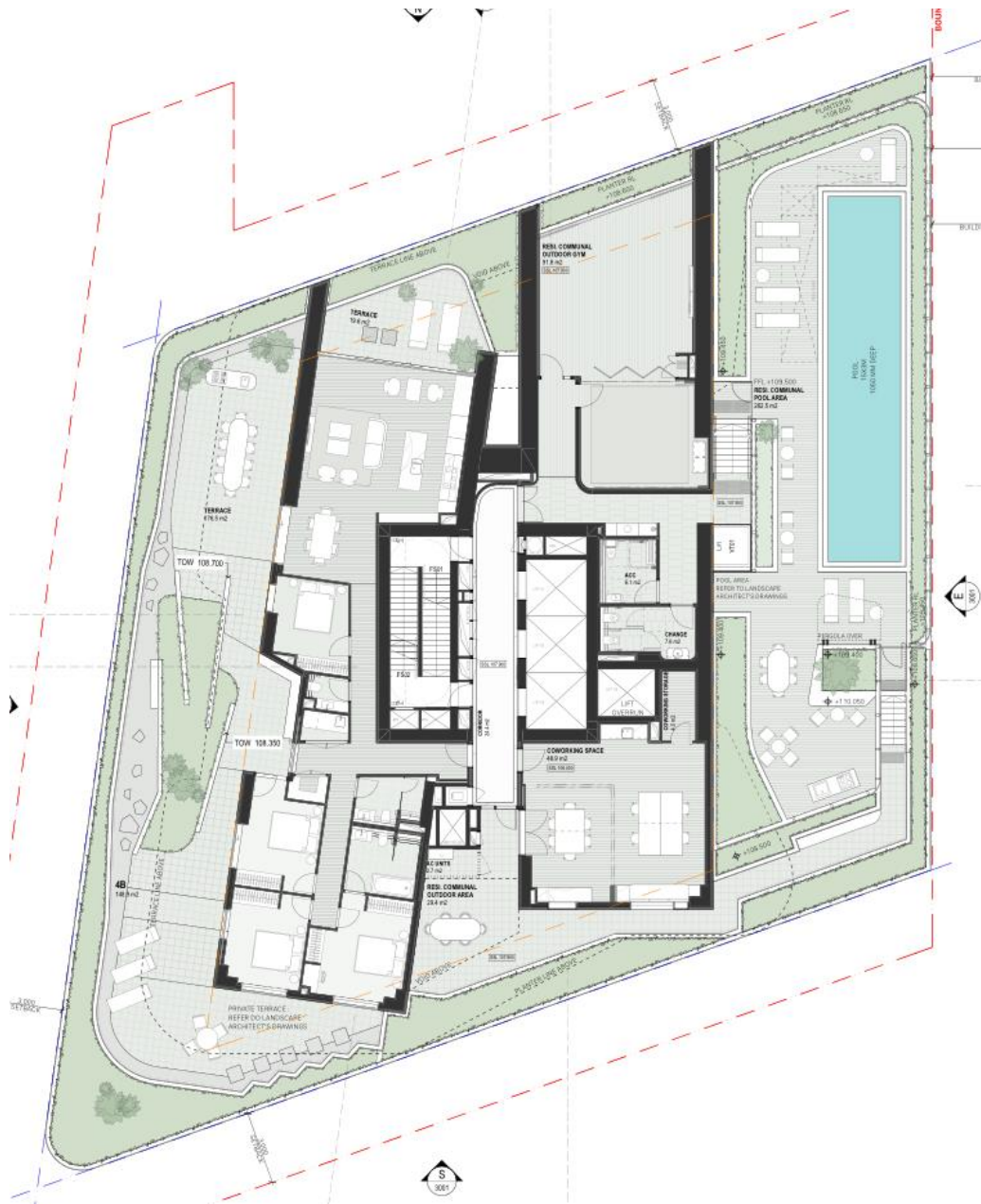

Figure 5: L02 podium terrace – Plan view.

WINDS FROM THE NORTH-EAST

Winds from the north-east quadrant will primarily approach over the low and medium-rise buildings of Chatswood. Winds from this quadrant are relatively unimpeded approaching the development. Pedestrian areas along the northern and eastern boundaries of the development may be affected by stronger breezes as the tower massing directs wind along these areas. The proposed and existing landscaping along the northern and eastern boundaries of the site will mitigate against any strong winds by preventing the use of the windiest areas by pedestrians.

As the tower is taller than the upwind surrounds, winds from the north-east are likely to be directed toward the ground in the form of downwash. The orientation of the tower relative to winds from the north-east would minimise downwash effects from the tower façade due to the oblique approach angle of the wind. Winds from this quadrant would impinge on the north-eastern corner of the tower, which would direct the flow horizontally around the tower with minimal downwash. The setback of the tower from the podium is also beneficial as it will assist in deflecting downwash flow away from ground level. However, windier conditions are likely to arise on the podium rooftop level.

Relatively high wind speeds would be expected on the stepped balconies and communal, eastern side of the podium terrace during winds from the north-east. The tower setback from the podium edge will concentrate the impact of downwash generated from the east façade of the tower on the podium level. The addition of an awning extending from the L03 terrace, particularly at the podium deck entrance, will help reduce the impact of such flows on the podium terrace. The proposed planters at the podium perimeter, in conjunction with a tall balustrade, will help to reduce the impact of strong cross flows from impacting the area, provided they are sufficiently high (1.8 m). Furthermore, the proposed pergola on the podium deck will create a local area of calm, increasing the amount of time residents can use the space, and is recommended to be retained.

During wind from the north-east, conditions for public domain locations on the southern (Gordon Avenue) and western (Hammond Lane) side of the site are expected to remain generally mild due to the shielding provided by the massing of the development. Most areas around the site would be expected to satisfy the Lawson distress criterion. Higher wind speeds resulting in a safety rating of Able-Bodied may occur on the podium terrace and at windward corners of the development.

WINDS FROM THE SOUTH

Winds from the south quadrant will pass over the low-rise buildings of Artarmon, reaching the proposed development relatively unimpeded. The proposed developments to the south of Gordon Avenue may offer some increased protection from southerly winds.

Incoming flow will impinge on the southern façade generating downwash flows, which are expected to be dissipated in large part due to the podium setback and stepped balcony arrangement on the southern side of the tower.

The placement of ground-level awnings, Figure 6, and podium setback are expected to deflect the majority of this downwash away from ground level, with the awnings also providing rain protection for residents and visitors. The lobby entries are well recessed within the building line, creating calm conditions for pedestrians as they enter/exit the building. Reasonably mild wind conditions are also expected around retail entrances as they are within the awning line and situated away from the building corners.

Southerly winds are likely to accelerate around the southern corners of the podium and have some impact on the proposed outdoor seating areas at the south-western and south-eastern region of the podium L02. This area would benefit from the use of portable vertical screens or raised planter boxes placed perpendicular to the building façade line to create localised areas of calm on windier days.

Wind conditions on the private and communal podium terraces and lower balconies are expected to be relatively windy due to direct exposure to winds from the south combined with vertical downwash generated from tower facades. Tall balustrades and perimeter landscaping as currently proposed are suggested to help mitigate strong winds originating from this direction. Awnings at the tower bases will also offer protected areas on the terrace and it is recommended these are retained.

Outdoor spaces on the northern side including the podium terrace and ground level north of the development are expected to remain mostly mild during southerly winds, being shielded by the tower itself.

Areas around the site, away from building corners and where nearby buildings can provide protection from southerly winds, are expected to pass the safety/distress criterion during winds from the south.



Figure 6: South elevation of the proposed development.

WINDS FROM THE WEST

Winds from the west quadrant will pass over the low-rise buildings of Chatswood West and are relatively unimpeded upon reaching the proposed development site. A slight increase in wind speeds is expected to occur due to an increase in terrain upon reaching the site. Existing buildings to the west will offer some protection to ground level at the site from direct westerly winds, although the tower remains relatively exposed.

These winds will impinge upon the broad western façade, generating downwash flow. The tower setback from the western podium edge is considered sufficient to deflect the majority of downwash flow coming off the west façade away from ground level. Stepped balconies on L03, L04 and L05 will also assist in dissipating downwash flow at these levels, effectively increasing the tower setback distance. The proposed horizontal awning over ground level on the western façade will provide some protection from downwash flow for pedestrian in this area and it is suggested this feature be retained. Slightly windier conditions are likely to be found at the windward corners of the site during winds from the west, as previously noted localised screening features near any outdoor seating areas in this space are recommended. Existing landscaping including large street trees on this side of the site will also marginally mitigate wind speeds at ground level, it is also suggested these be retained.

Wind conditions near main entries to the south, portions of the pool deck and northern terraces are expected to be relatively shielded during winds from the west. Partition walls on the northern terraces are considered beneficial to protect from any strong westerly winds. Reasonably strong breezes are expected to arise along Hammond Lane, however conditions would remain similar to the existing at this location.

Most areas around the site are expected to pass the safety/distress criterion during winds from the west. Locations at building corners, or exposed to westerly winds, may be rated Able-Bodied.

SUMMARY – PUBLIC DOMAIN

For most locations, wind conditions within the proposed development site are expected to remain similar to the existing wind conditions. From a pedestrian comfort perspective, the wind environment around the proposed development site is likely to be classified as acceptable for Pedestrian Standing or Walking under Lawson. These pedestrian comfort levels would be suitable for public accessways, and for stationary short-term exposure activities. Most locations would be expected to satisfy the safety/distress criterion, with some locations potentially exceeding these with an Able-Bodied rating.

WIND CONDITIONS WITHIN THE DEVELOPMENT

Several locations throughout the development are relatively exposed from a wind perspective, and amelioration measures may be required to achieve wind amenity suitable for the intended use of space.

PODIUM TERRACE

The podium is relatively exposed from a wind perspective, particularly from direct winds and downwash generated off the tower facades as noted in previous sections. The use of awnings around the perimeter of the tower and the partitioning of terrace spaces will reduce the impact of downwash and accelerated direct flows on this area. The pool deck area however remains relatively exposed, particularly during winds from the north-east, and may benefit from an extension of the awning on this aspect. The proposed 1.8m high perimeter balustrade will provide substantial shielding for the podium BBQ area and pool deck, creating localised areas with mild wind conditions that are suitable for the intended use of the space.

The podium recreation space is less likely to be used during periods of inclement weather, when high wind speeds are anticipated. Therefore, further mitigation may not be required and will depend on the intended use of specific areas on the podium.

BALCONIES

Balconies are distributed over the development. Wind conditions on the balconies are generally expected to be mild as they are recessed into the eastern and western facades, and effectively partitioned on the northern and southern facades, and are therefore protected from strong cross flows that often create undesirable conditions on elevated balconies. It should be noted that it is relatively common for such elevated and exposed balconies to experience stronger wind conditions at times. As such, residents tend to learn to determine the usability of their balconies over time based on the seasonal and temporal weather conditions.

PRIVATE ROOFTOP TERRACE

Most areas on the rooftop terrace are expected to be relatively mild due to the protection provided by the high perimeter balustrade, small awnings, landscaping and massing of the plant and the lift overrun at the centre as shown in Figure 7. The inclusion of sunken or booth-style seating may be employed to further improve wind conditions on the rooftop terrace if casual outdoor dining or similar activity is desired.

The requirements for wind amelioration for terraces will depend on the intended use of these spaces. Conditions on terraces and balconies are likely to be similar to or better than those on comparable developments in the region, and no specific requirement for mitigation measures is foreseen for normal discretionary use.

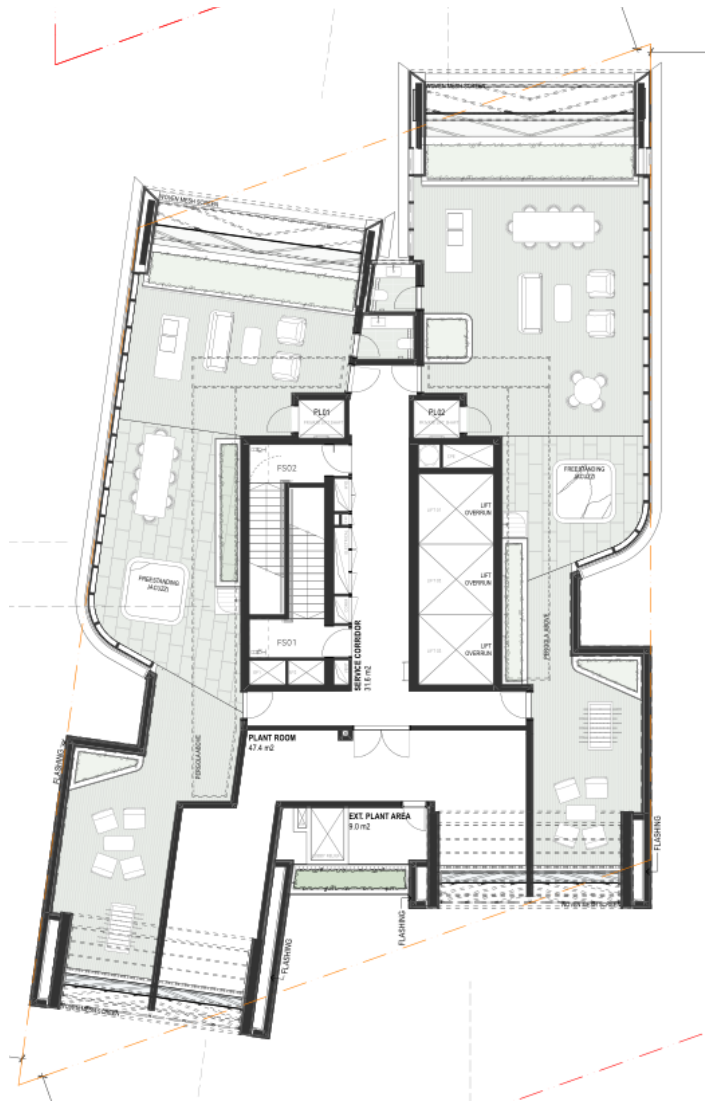

Figure 7: Level 34 Roof Terrace – Plan view.

4. Conclusion

Cermak Peterka Petersen Pty. Ltd. has provided a qualitative assessment of the impact of the proposed Hammond Greens project on the local wind environment in and around the development site. Being significantly larger than most surrounding structures, the proposed development will have some effect on the local wind environment, though any changes are not expected to be significant from the perspective of pedestrian comfort largely due to the tower setback above the podium. Wind conditions around the development are expected to be classified as acceptable for Pedestrian Standing or Walking from a Lawson comfort perspective, with most areas passing the distress/safety criterion. Higher wind speeds may occur in some areas of the development, particularly at tower corners and on the podium terrace. These areas may slightly exceed the recommended safety criterion.

References

Lawson, T.V. (1990), "The Determination of the Wind Environment of a Building Complex before Construction" Department of Aerospace Engineering, University of Bristol, Report Number TVL 9025.

Willoughby City Council (2016), "Willoughby Development Control Plan"

Appendix A – Wind Flow Mechanisms

When the wind hits a large isolated building, the wind is accelerated down and around the windward corners, Figure A1 this flow mechanism is called downwash and causes the windiest conditions at ground level on the windward corners and sides of the building. In Figure A1 smoke is being released into the wind flow to allow the wind speed, turbulence, and direction to be visualised. The image on the left shows smoke being released across the windward face, and the image on the right shows smoke being released into the flow at about third height in the centre of the face.

Techniques to mitigate the effects of downwash winds on pedestrians include the provision of horizontal elements, the most effective being a podium to divert the flow away from pavements and building entrances. Awnings along street frontages perform a similar function, and the larger the horizontal element, the more effective it will be in diverting the flow.

Channelling occurs when the wind is accelerated between two buildings or along straight streets with buildings on either side.

Figure A2 shows the wind at mid and upper levels on a building being accelerated substantially around the corners of the building. When balconies are located on these corners, they are likely to be breezy, and will be used less by the owner due to the regularity of stronger winds. Owners quickly become familiar with when and how to use their balconies. If the corner balconies are deep enough, articulated, or have regular partition privacy fins, then local calmer conditions can exist.

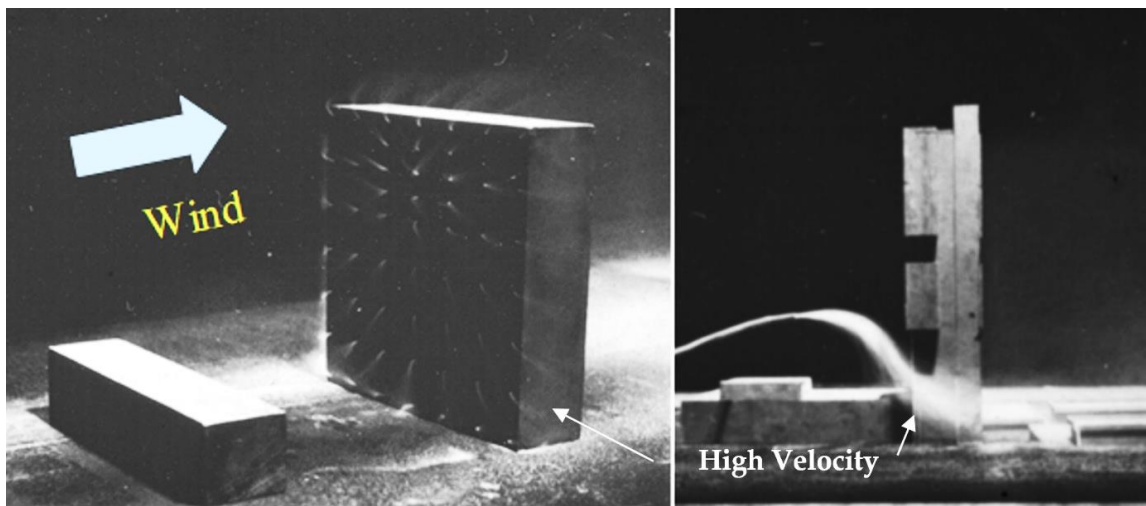

Figure A1: Flow visualisation around a tall building.



Figure A2: Channelling between buildings (L) and visualisation through corner balconies (R).

Appendix B - Wind Impact Planning Guidelines

It is well known that the design of a building will influence the quality of the ambient wind environment at its base. Below are some suggested wind mitigation strategies that should be adopted into precinct planning guidelines and controls (see also Cochran, 2004).

Building form – Canopies

A large canopy may interrupt the flow as it moves down the windward face of the building. This will protect the entrances and sidewalk area by deflecting the downwash at the second storey level, Figure B1. However, this approach may have the effect of transferring the breezy conditions to the other side of the street. Large canopies are a common feature near the main entrances of large office buildings.

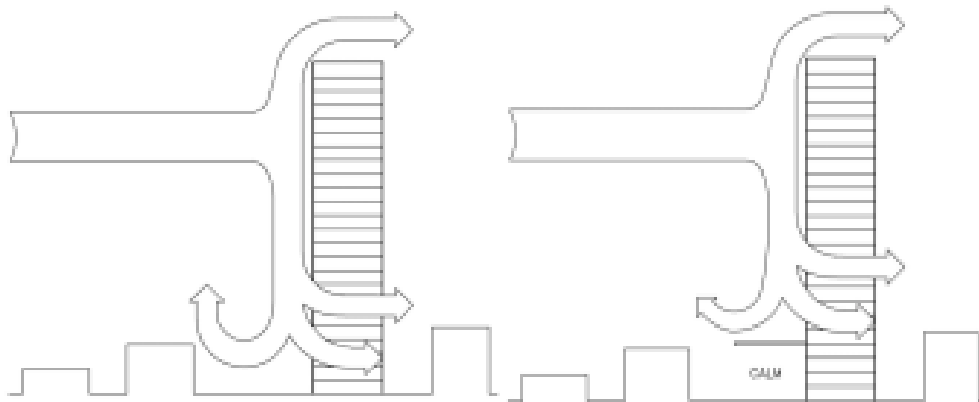

Figure B1: Canopy Windbreak Treatment. (L) Downwash to street level may generate windy conditions for pedestrians. (R) A large canopy is a common solution to this pedestrian-wind problem at street level.

Building form – Podiums

The architect may elect to use an extensive podium for the same purpose, Figure B2, if it complies with the design mandate. This is a common architectural feature for many major projects, but it may be counterproductive if the architect wishes to use the podium roof for long-term pedestrian activities, such as a pool or tennis court.

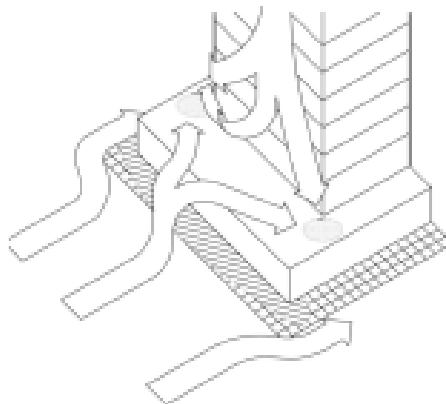

Figure B2: The tower-on-podium massing often results in reasonable conditions at ground level, but the podium may not be useable.

Building form – Arcades

Another massing issue, which may be a cause of strong ground-level winds, is an arcade or thoroughfare opening from one side of the building to the other. This effectively connects a positive pressure region on the windward side with a negative pressure region on the lee side; a strong flow through the opening often results, Figure B3. The uninvitingly windy nature of these open areas is a contributing reason behind the use of arcade airlock entrances (revolving or double sliding doors).

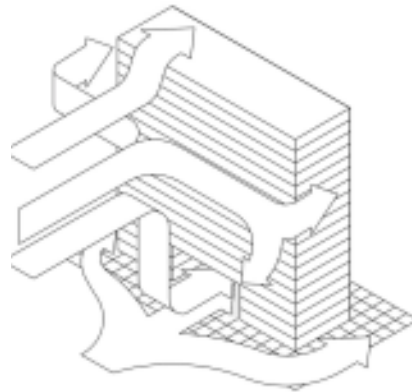

Figure B3: An arcade or open column plaza under a building frequently generates strong pedestrian wind condition.

Building form – Alcove

An entrance alcove behind the building line will generally produce a calmer entrance area at a mid-building location, Figure B4(L). In some cases, a canopy may not be necessary with this scenario, depending on the local geometry and directional wind characteristics. The same undercut design at a building corner is usually quite unsuccessful, Figure B4 (R), due to the accelerated flow mechanism described in Figure B1 and the ambient directional wind statistics. If there is a strong directional wind preference, and the corner door is shielded from those common stronger winds, then the corner entrance may work. However, it is more common for a corner entrance to be adversely impacted by this local building geometry. The result can range from simply unpleasant conditions to a frequent inability to open the doors.

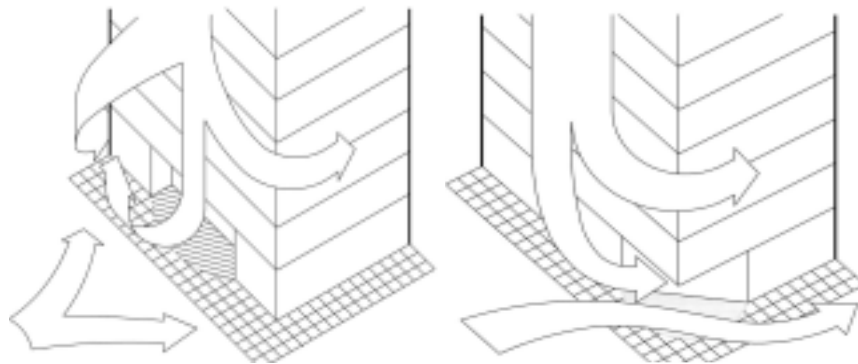

Figure B4: Alcove Windbreak Treatment. (L) A mid-building alcove entrance usually results in an inviting and calm location. (R) Accelerated corner flow from downwash often yields an unpleasant entrance area.

Building form – Façade profile and balconies

The way in which a building's vertical line is broken up may also have an impact. For example, if the floor plans have a decreasing area with increased height the flow down the stepped windward face may be greatly diminished. To a lesser extent the presence of many balconies can have a similar impact on ground level winds, although this is far less certain and more geometry dependent. Apartment designs with many elevated balconies and terrace areas near building ends or corners often attract a windy environment to those locations. Mid-building balconies, on the broad face, are usually a lot calmer, especially if they are recessed. Corner balconies are generally a lot windier and so the owner is likely to be selective about when the balcony is used or endeavours to find a protected portion of the balcony that allows more frequent use, even when the wind is blowing.

Use of canopies, trellises, and high canopy foliage

Downwash Mitigation – As noted earlier, downwash off a tower may be deflected away from ground-level pedestrian areas by large canopies or podium blocks. The downwash then effectively impacts the canopy or podium roof rather than the public areas at the base of the tower, Figure B2. Provided that the podium roof area is not intended for long-term recreational use (e.g. swimming pool or tennis court), this massing method is typically quite successful. However, some large recreational areas may need the wind to be deflected away without blocking the sun (e.g. a pool deck), and so a large canopy is not an option. Downwash deflected over expansive decks like these may often be improved by installing elevated trellis structures or a dense network of trees to create a high, bushy canopy over the long-term recreational areas. Various architecturally acceptable ideas may be explored in the wind tunnel prior to any major financial commitment on the project site.

Horizontally accelerated flows between two tall towers may cause an unpleasant, windy, ground-level pedestrian environment, which could also be locally aggravated by ground topography. Horizontally accelerated flows that create a windy environment are best dealt with by using vertical porous screens or substantial landscaping. Large hedges, bushes or other porous media serve to retard the flow and absorb the energy produced by the wind. A solidity ratio (i.e. proportion of solid area to total area) of about 60-70% has been shown to be most effective in reducing the flow's momentum. These physical changes to the pedestrian areas are most easily evaluated by a model study in a boundary-layer wind tunnel.

References

Cochran L., (2004) Design Features to Change and/or Ameliorate Pedestrian Wind Conditions, Proceedings of the ASCE Structures Congress, Nashville, Tennessee, May 2004.