



Robert Bird Group

Integrated Water Management
Report for

**Blacktown Mount Druitt Hospital
Stage 2 Redevelopment
SSD DA for Bulk Excavation
(Early Works Package 2)**

Issue: 4

Prepared For: Health Infrastructure

Project No.: 10684X

28th September 2015

Document No.: 10684X-HI RPT-C-IWMR-150928



Table of Contents

1.0	Introduction.....	1
1.1	Purpose of Document	1
1.2	Project Scope.....	1
1.3	Site Description.....	3
1.4	Survey	3
2.0	Flooding.....	3
3.0	Stormwater Drainage Design	3
3.1	Overview	3
3.2	Codes and Specifications	4
3.3	Design Criteria	4
3.4	On-Site Detention	5
4.0	Water Sensitive Urban Design (WSUD).....	5
4.1	Water Quality Objectives	5
4.2	WSUD Approach.....	6
4.3	Proposed WSUD Elements	6
4.4	Maintenance of Water Quality Treatment Devices	7
5.0	Erosion and Sediment Control	8
6.0	Water and Wastewater Management.....	8
6.1	Potable Water Demand Reduction	8

Appendices

Appendix A – Flood Map and Catchment Plan

Appendix B – Civil Engineering Drawings

This report has been prepared on behalf of and for the exclusive use of the Client, and is subject to and issued in accordance with the agreement between the Client and Robert Bird Group Pty Ltd. Robert Bird Group Pty Ltd accepts no liability or responsibility whatsoever for any use of or reliance upon this report by any third party. Any copying of this report to external parties requires the permission of the Client and Robert Bird Group Pty Ltd.

1.0 Introduction

1.1 Purpose of Document

Robert Bird Group (RBG) has been engaged by Health Infrastructure to design the Civil Engineering works for the Blacktown Mount Druitt Hospital Stage 2 Expansion.

This report has been prepared to address the Secretary's Environmental Assessment Requirements (SEARs) that have been issued for this project and specifically Requirements 11 and 13, as follows:

11 - Utilities: "Prepare an Integrated Water Management Plan detailing any proposed alternative water supply, proposed end users of potable and non-potable water, demonstration of water sensitive urban design and water conservation measures."

13 – Drainage: "Provide details of the drainage associated with the proposal, including stormwater, drainage infrastructure and OSD, which shall be designed in consultation with Council and must avoid any adverse impacts on downstream properties."

This report supports a State Significant Development (SSD) Development Application (DA) submitted to the Minister for Planning and Environment pursuant to Part 4 of the Environmental Planning and Assessment Act 1979 (EP&A Act). The Application is identified as a Stage 1 SSD DA for the Building Envelope, with detailed design of the bulk excavation works.

A range of water management and drainage works are also being constructed as part of a REF for Campus - wide infrastructure upgrades and services diversions.

The design and coordination of water supply and wastewater services is the responsibility of Warren Smith & Partners (WSP). WSP has provided preliminary advice for this report.

1.2 Project Scope

The scope of the Stage 2 development is generally described by the Preliminary Business Case reports by PWC and Health Infrastructure NSW, dated October 2014. The business case is expected to be finalised by the end of 2015.



Figure 1.1 – Blacktown Hospital Stage 2

SSD Works

The works comprising this SSD are:

- Concept design of a new Clinical Services Building (CSB), located to the west of the Stage 1 CSB. Along the western side of the building on Level 2 an Emergency Department (ED) and Ambulance Bay will be provided with driveway access at this level.
- Design drawings of the shoring and bulk excavation works for the new CSB. Bulk excavation plans are included in Appendix B of this report. The shoring systems for the excavation are described in the Structural and Civil Engineering Design Report.

Other civil engineering early works are subject to a separate Review of Environmental Factors (REF) application and are therefore not part of this SSD DA. These works comprise the following elements.

- Reconstruction of the Main Loop Road from Panorama Parade \ Marcel Crescent to the Stage 2 Multi-level Carpark and including:
- Services and stormwater diversions and amplification around the Stage 2 CSB and UWS including:
 - i. Modification of the detention basin north of UWS to also address water quality treatment and any increased storage requirement.
 - ii. Hydraulic services extension around Stage 2 from the Stage 1 works to UWS.
- Provision of a new loading dock adjacent to the existing administration building at the southern end of the site.

1.3 Site Description

The site is described as Lots 300, 301, 306, 308 DP15914, Lot 1 DP 128344, Lot 3 in DP71010 and Lot 1 in DP730307 at Blacktown Road, Blacktown and has an overall area of 12.335 hectares.

The site has frontage to Blacktown Road to the North and abuts residences on the other boundaries. It falls generally from south to north with an overall fall from approximately RL 72.50 AHD at the highest point on the southern boundary, to approximately RL 46.00m AHD at the lowest point on at the northern boundary adjacent to Blacktown Road.

The site is currently occupied by the existing hospital, outpatient buildings and car parking areas.

1.4 Survey

The survey that has been used in the preparation of the report is:

- Blacktown Hospital Plan Showing Levels, Details, Contours and Services Drawing Number 116973500 Issue 03 prepared by Cardno Hard & Forester.

2.0 Flooding

Due to its elevation the hospital site is not within a flood affected zone as confirmed by reference to Council flood maps, a copy of which is included in Appendix A

Internally road and car park levels and grades have been set to ensure no localised flooding of the existing and new buildings and also not to impact adversely on the adjoining properties

3.0 Stormwater Drainage Design

3.1 Overview

The stormwater proposal as part of the REF address the need to divert the existing system which will be demolished where it traverse the Stage 2 site. Roof drainage from the proposed building will also connect into the new stormwater system.

The key issues include:

- Diversion and upgrade of the stormwater network to the 1% AEP (1 in 100 year) storm event to capture the western catchments of the campus (refer to the catchment plan in Appendix A). The stormwater system is to be diverted around the UWS building to the detention basin north of UWS near Blacktown Road.
- In addition to Stage 1 improvements, the proposed diversion will further reduce the area of catchment that is directed to an existing pipe through the UWS building. The significant reduction will alleviate capacity and maintenance issues experience by UWS and diversion and amplification of the stormwater around UWS will also be designed to address possible future development of Bungarabee House and buildings to its south.
- Modification of the existing detention basin to a combined detention and bio retention basin in addition to upstream water quality measures is proposed to meet current Water Sensitive Urban Design (WSUD) standards including the requirements of Blacktown City Council.

3.2 Codes and Specifications

The stormwater design of the project was carried out in accordance with the relevant local, state and national design guidelines (where not over-ridden by Blacktown City Council requirements) and Australian Standard Codes of Practice, including:

- Australian Rainfall and Runoff – A Guide to Flood Estimation, Volumes 1 and 2 (1987) – The Institution of Engineers, Australia.
- AS/NZS 3500.3.2 National Plumbing and Drainage Part 3.2: Stormwater Drainage – Acceptable Solutions.
- On-Site Stormwater Detention Handbook (Fourth Edition, December 2005) – Upper Parramatta River Catchment Trust.
- Managing Urban Stormwater – Soils and Construction Volume 1 (4th Edition, March 2004) – NSW Department of Housing.
- Blacktown City Council Engineering Guidelines for Development – 2005
- Blacktown City Council Development Control Plan 2015 Part J Water Sensitive Urban Design and Integrated Water Cycle Management.

3.3 Design Criteria

Stormwater management controls from Blacktown City Council's DCP 2015 and additional design considerations have been addressed in the design and are summarised as follows:

STORMWATER MANAGEMENT CONTROL	
Item	Control or Design Objective
Minor and Major Storms (ARI)	<p>Minor Storm – All new pipes and associated components to be designed to cater for the 20 year ARI storm east of the Bungarabee House car park turnoff and increasing to the 100 year ARI storm from in front of the Emergency Department through to the stormwater detention basin.</p> <p>Major Storm – All overland flow paths to be designed to cater for the 100 year ARI storm.</p>
Determining Flow Rate – Hydrology and Hydraulics	Where the catchments are large and/or a higher confidence in the flow rate prediction is necessary, peak flow rate should be determined using runoff routing computer models. For this project DRAINS shall be used for hydrological modelling.
Pipe Velocities	Pipe velocities shall be between 0.5 m/s and 7.0 m/s and preferably between 1.0 m/s and 5.0 m/s during the design storm to ensure the flow is self-cleansing but not likely to cause scour.
Pit Blockage Factor	A pit blockage factor of 0.3 has been applied to all grated inlet pits in the hydrological models.
Pipe Grades	The minimum pipe grade shall be generally 1.0%, however under exceptional circumstances a grade of 0.5% may be permitted.
Overland Flow Paths	The design of the overland flow path must consider the velocity-depth hazard. For this project, depth x velocity values should not exceed

0.4 for reasons of pedestrian safety

Table 4.1 – Stormwater Management Controls and Design Objectives

3.4 On-Site Detention

On-site stormwater detention is a stormwater management measure designed to limit the peak stormwater flow from a site to either pre-development peak flows or a flow set by the regulatory authority. Blacktown Hospital is within the Upper Parramatta River Catchment, and stormwater detention measures for the area have been set by the Upper Parramatta River Catchment Trust (UPRCT) and adopted by Blacktown City Council.

The design parameters and methodology for on-site detention are set out in the Trust’s On-Site Stormwater Detention Handbook (Fourth Edition, December 2005) and these base parameters are summarised as follows:

Overall Site Storage Requirement (SSR)	455 cu.m./hectare
Primary Site Reference Discharge (SRDL)	40 litres/second/hectare
Secondary Site Reference Discharge (SRDU)	150 litres/second/hectare

The storage volume is divided into an upper storage and a lower storage. The lower storage is controlled by a smaller sized orifice plate, so that peak discharges from the 1.5-year ARI storm are attenuated to acceptable levels. The upper storage is controlled by a second orifice plate. The two orifice plates thereby attenuate flows from major storms (eg 100-year AR) to acceptable levels.

An existing detention basin is located between the UWS Building and Blacktown Road and was constructed in the late 1990s as part of the original hospital development.

The Stage 2 redevelopment will necessitate amplification and diversion of the piped network and with it an increase of the catchment to 6.03 hectares that will take in the stormwater from the original hospital building and UWS as well as Stage 2, Bungarribee House, Embark House and the Sub-Acute Mental Health Building and adjacent car parks. This catchment is defined as the western catchment, the extents of which are presented in a sketch in Appendix A. The capacity of the existing detention basin will be increased to suit the extended catchment area.

4.0 Water Sensitive Urban Design (WSUD)

4.1 Water Quality Objectives

Water Sensitive Urban Design (WSUD) measures will be provided in order to comply with SEARs requirement II, Utilities.

The WSUD design is to be in accordance with the Blacktown City Council Development Control Plan 2015 Part J Water Sensitive Urban Design and Integrated Water Cycle Management. These objectives are summarised in Table 4.1.

Stormwater Quality Management Targets	
Pollutant	Proposed Target
Total Suspended Solids (TSS)	85% reduction of average annual loads.
Total Phosphorous (TP)	65% reduction of average annual loads.
Total Nitrogen (TN)	45% reduction of average annual loads.

Stormwater Quality Management Targets	
Pollutant	Proposed Target
Gross Pollutants (>5mm)	90% reduction of average annual loads.
Areas of treatment	100% of all developed areas to be treated.

Table 4.1 – WSUD Objectives

4.2 WSUD Approach

Stormwater quality modelling is being undertaken for the site, in order to quantify the WSUD measures required to meet the development controls.

Water quality control will be achieved using a *treatment train* approach with the performance modelled in MUSIC. The treatment train will utilise WSUD elements as described in Section 4.3 in order to meet the DCP objectives.

4.3 Proposed WSUD Elements

Pit Filter Baskets

In-ground proprietary devices such as pit filter baskets (i.e. the Stormwater360 Enviropod) are an easily maintained inlet pit insert that is effective at removing litter, debris, and other pollutants from urban runoff. In the proposed treatment train five (5 No.) Enviropods have been modelled to treat sub-catchment areas. Stormwater360 MUSIC nodes have been used for simulating these proprietary products in the model.

Other proprietary devices may be substituted subject to demonstration they meet the required water quality treatment requirements.

Enviropods are proposed to treat roof and courtyard runoff before entering the GPT. Enviropods are also proposed in the Publicly Accessible Plaza area.

Gross Pollutant Trap

Gross Pollutant Traps or GPT's remove the larger solids from stormwater at high flow rates. Their purpose is to reduce the sediment load onto the next step in the process, the bio retention basin.

Smaller pollutants, such as dirt, chemicals, heavy metals and bacteria are not collected by the GPTs; however, some small particles are caught up in the larger items in the trap and thus prevented from reaching the waterway.

Bioretention

Bioretention systems are vegetated soil media filters, which treat stormwater by allowing it to pond on the vegetated surface and slowly infiltrate downwards through the soil media. Treated water is collected via subsoil perforated pipes and routed to downstream waterways or storage facilities for reuse. They are effective in reducing the concentration of suspended solids (TSS), phosphorus (TP) and especially nitrogen (TN) via nutrient uptake and denitrification.

Typically, a bioretention system will consist of three sub-surface layers (refer Figure 5.2).

- **Filtration Layer** – The filtration layer is the main media through which water is filtered and treated. Typically, it consists of a sandy loam mix with a saturated hydraulic conductivity of 100mm/hr to 300mm/hr under compaction. The depth of media ranges from 600mm to 800mm, dependant on the vegetation and/or tree species selected;

- **Transition Layer** – The transition layer typically consists of coarse sand (particle size 1mm) and is installed to prevent the filtration media washing into the perforated subsoil drainage. A transition layer of 100mm to 150mm is recommended.
- **Drainage Layer** – The drainage layer is at the bottom of the bioretention system and is placed to encase the subsoil drainage pipe. The typical thickness is 150mm and is to be a fine gravel mix (particle size 2-5mm).

Treatment can be enhanced by creating temporary ponding (extended detention depth) over the filter media. This increases the amount of time that runoff can infiltrate and also increase the volume to be treated. Generally the extended detention depth is between 100mm to 300mm.

Vegetation plays an important role in the efficiency of bioretention systems. The surface is densely planted with grasses, sedges and select shrub or tree species, which acts to retard and distribute the flows across the filter media. Below ground the root zone of the plants is highly biologically active. As water passes through this zone, materials (both fine soils and soluble nutrients) can be physically trapped or be actively taken up by the plant roots of other plant biota (bacteria and fungi). The plant growth and death cycle also plays an important role, maintaining the soil structure and hydraulic conductivity of the media.

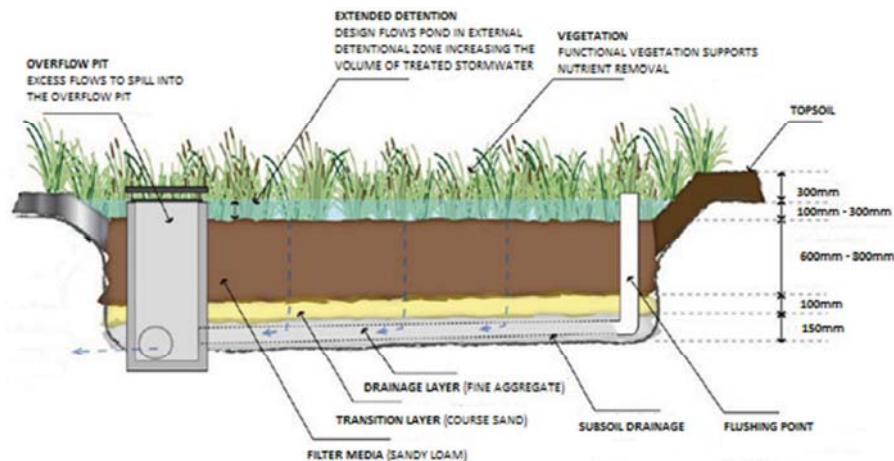

Figure 5.2 – Typical Section of a Bioretention System

4.4 Maintenance of Water Quality Treatment Devices

Water quality treatment devices require regular maintenance. A detailed maintenance plan will be developed following final selection of the treatment devices to be installed. An indicative maintenance plan is provided below.

- **Gross Pollutant Traps**
 - In accordance with the manufacturer's technical manual and owner's manual;
 - Periodic (6 monthly and after heavy rain) inspection/minor maintenance, cleaning and removal of vegetation and debris (where required);
 - Periodic (yearly) major maintenance, cartridge recharging
- **Stormwater360 Enviropods**
 - In accordance with the manufacturer's technical manual and owner's manual;
 - Periodic (6 monthly) inspection, cleaning and removal of any gross pollutants and coarse sediment that is deposited in the device.
- **Bio-retention**

- Routine inspection (3-6 monthly and after heavy rain), cleaning and maintenance of the bio-retention systems. Check inlets and overflow structures/drainage pipes for scour and sediment. Removal of litter, debris and sediment;
- Inspection of filter media porosity (3-6 monthly and after heavy rain). Check for accumulation of impermeable layer. Remove sediment and scarify;
- Over time, the filter media will accumulate fine sediments. The filter media should be replaced when its infiltration capacity is reduced due to binding. Typically, filtration media should be replaced every 5-7 years.

5.0 Erosion and Sediment Control

The quality of stormwater discharge from the site during the construction stage will be managed using erosion and sediment control and surface water management measures in accordance with the Landcom guidelines – Managing Urban Stormwater Runoff: Soils and Construction (“Blue Book”) and Blacktown City Council’s DCP. A concept sediment and erosion control plan is provided in Appendix B.

Potential erosion and sediment control measures for the development may include, but not be limited to, the following:

- Settling tanks/basins;
- Surface water collection systems i.e. drains to collect construction site runoff and convey flows to control and treatment systems ;
- Shaker grid and wash down areas at vehicle entry points; and,
- Sediment protection devices on existing and proposed inlet pits.

6.0 Water and Wastewater Management

6.1 Potable Water Demand Reduction

Opportunities exist for reducing the demand and load on local water and wastewater infrastructure that contribute to improving water cycle management in order to comply with SEARs (requirement II, Utilities). Several options for consideration by the design team are provided below for further investigation in design development stages.

The following potable water demand reduction strategies will be incorporated:

- Selection of water efficient fixtures with appropriate WELS ratings shall be used;
- Fire systems design to include for recycling of test fire water;
- Harvesting rainwater from metal and concrete roofs for re-use as toilet flushing and landscape irrigation (***strategy is subject to a cost-benefit analysis during the design development stage***);
- Installation of pulse water meters (to Sydney Water standards) for all major uses of water for data collection and water-leak detection; and,
- Selection of drought tolerant landscape elements that require low irrigation water demand.

Appendix A

Flood Map and Catchment Plan

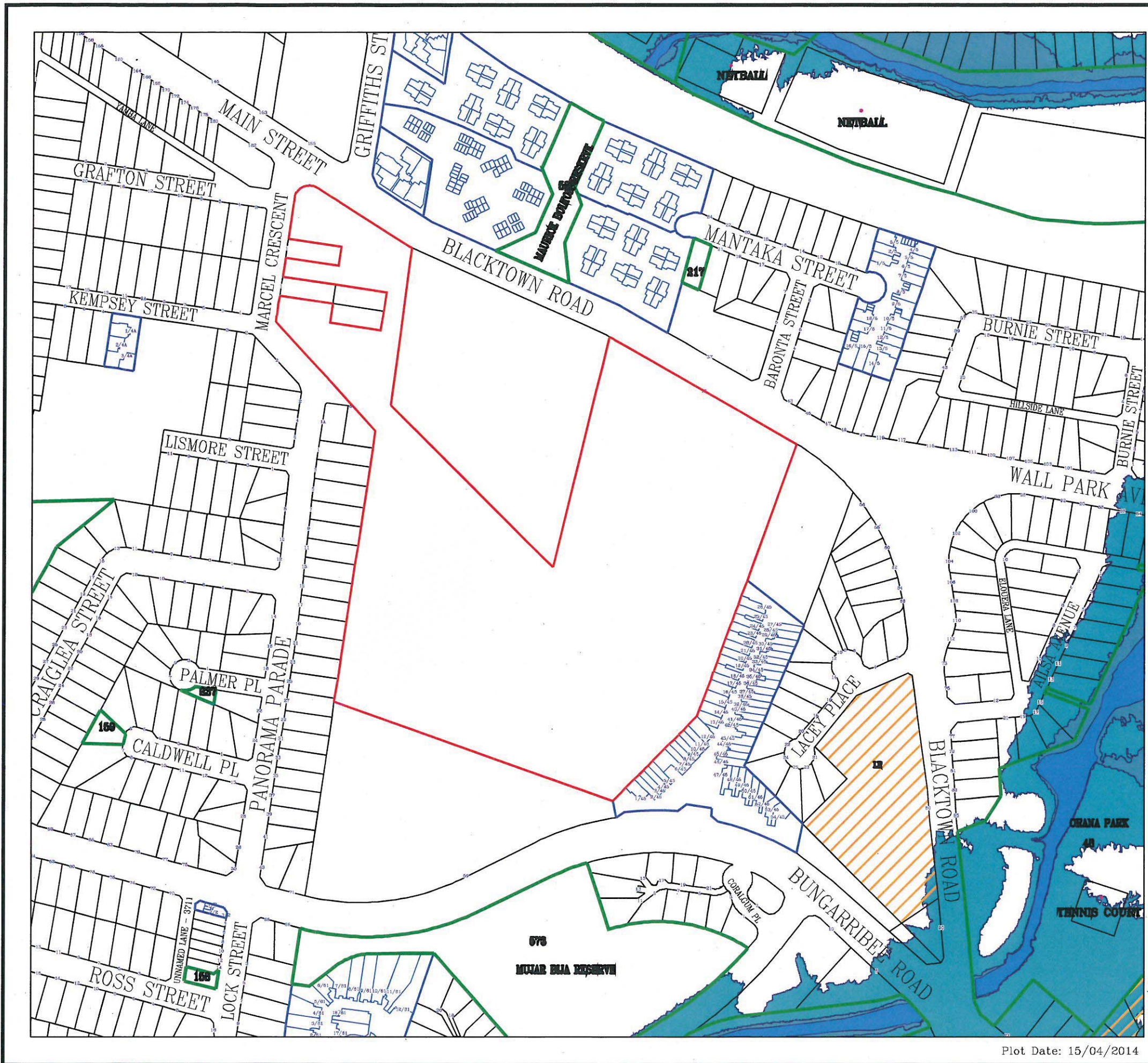

LEGEND

- Lot Parcel.Coverage
- Lot Parcel.Coverage - Strata Unit
- Lot Parcel.Coverage - Torrens Title
- Strata Development Coverage.Coverage - Registered
- Reserve Coverage.Registered Coverage
- Local Government Area.Boundary
- Places Of Interest - Council.Coverage
- Places Of Interest - Council.Places Of Interest Location - Council
- Flood Extents.High Flood Risk Precinct
- Flood Extents.Low Flood Risk Precinct
- Flood Extents.Medium Flood Risk Precinct
- Flood Local.Minor Coverage



nation provided is indicative only and should not be relied upon without further certification by Blacktown City Council.

Street Directory Copyright Melway Publishing Pty. Ltd.



Plot Date: 15/04/2014

Upgrade existing detention basin for total 3000m³ for catchment 1-6, total area 6.28ha.

Existing Drainage Network

Retention Option 1: Provide Bio-retention approx. 1300m² in detention storage

Proposed Stormwater Drainage line DIA. 1050mm (ARI 100year) discharging to Detention/Retention Basin. Catchment 4-6, total area 3.82ha.

Divert existing drainage line to the West if necessary

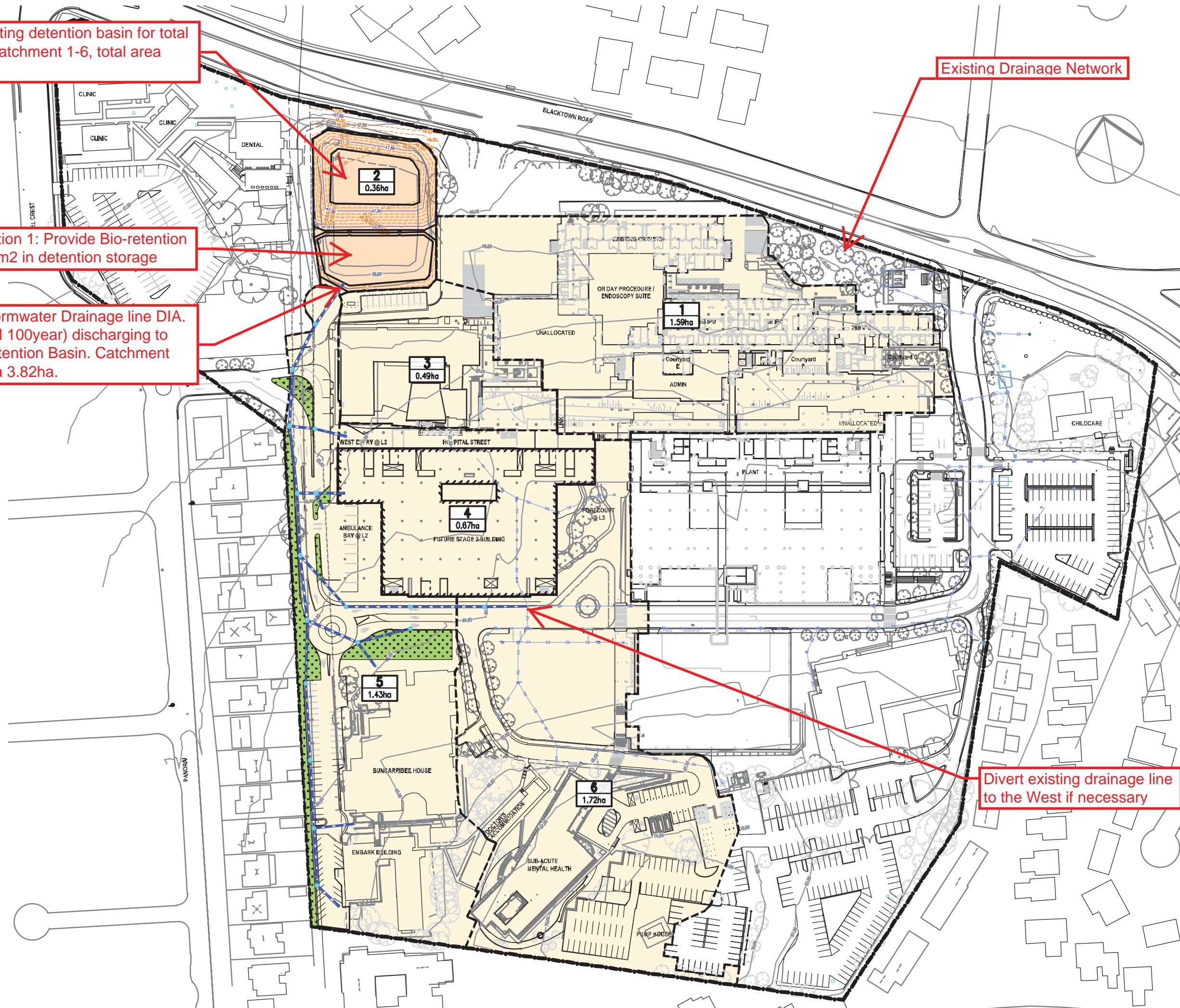

Appendix B

Civil Engineering Drawings

BLACKTOWN MT DRUITT HOSPITAL STAGE 2 (BIN2) CIVIL INFRASTRUCTURE EARLY WORKS PACKAGE 2 - CSB BULK EARTHWORKS -



LOCATION PLAN
SCALE: NTS

EARLY WORKS PACKAGE 2 DRAWING TABLE	
DRAWING NUMBER	DRAWING TITLE
BIN2-CV-DG-1000	COVER SHEET
BIN2-CV-DG-1101	EROSION & SEDIMENT CONTROL PLAN
BIN2-CV-DG-1110	EROSION & SEDIMENT CONTROL NOTES & DETAILS
BIN2-CV-DG-1201	BULK EARTHWORKS PLAN
BIN2-CV-DG-1210	BULK EARTHWORKS SECTIONS
BIN2-CV-DG-1301	GENERAL ARRANGEMENT PLAN

Disclaimer: Robert Bird Group Pty Ltd (RBG) does not warrant, represent or guarantee the accuracy, completeness or reliability of any information or data supplied or transferred to you (including copyright in all text, graphics, logos, icons, sound recordings and software) or created by or licensed to RBG. Other than for purposes authorised by RBG in writing, you must not copy, disseminate, reproduce, store, publish or commercialise any information or data supplied or transferred in electronic media without RBG's prior written permission. © Robert Bird Group Pty Ltd 2011.

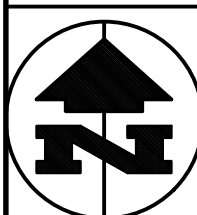

Unless agreed otherwise by Robert Bird Group Pty Ltd ("RBG") ADN 010 580 248 in writing, intellectual property rights in any information or data supplied or transferred to you (including copyright in all text, graphics, logos, icons, sound recordings and software) are owned by, or licensed to, RBG. Other than for purposes authorised by RBG in writing, you must not copy, disseminate, reproduce, store, publish or commercialise any information or data supplied or transferred in electronic media without RBG's prior written permission. © Robert Bird Group Pty Ltd 2011.

DO NOT SCALE DRAWINGS, USE FIGURED DIMENSIONS

REV.	DATE	BY	APPD BY	APPD P.D.R.	AMENDMENT
1	29.09.15	LAR	CR		ISSUED FOR SSD

CONSULTANT		PROJECT MANAGER		MAIN CONTRACTOR		PRINCIPAL		
Date generated 29.09.15	Drawn M. GUNDEL Checked C. WHITE	Design L. RUSSELL Approved C. ROPE						

PROJECT	
BLACKTOWN MT DRUITT HOSPITAL STAGE 2 BLACKTOWN CAMPUS: BLACKTOWN ROAD, NSW 2148	

CIVIL	
DRAWING TITLE BIN2 - EARLY WORKS PACKAGE 2 - CSB BULK EARTHWORKS	
COVER SHEET	
SCALE (B1)	AS NOTED
PROJECT No:	10684Y
DRAWING No:	BIN2-CV-DG-1000

FOR INFORMATION	
REVISION	1

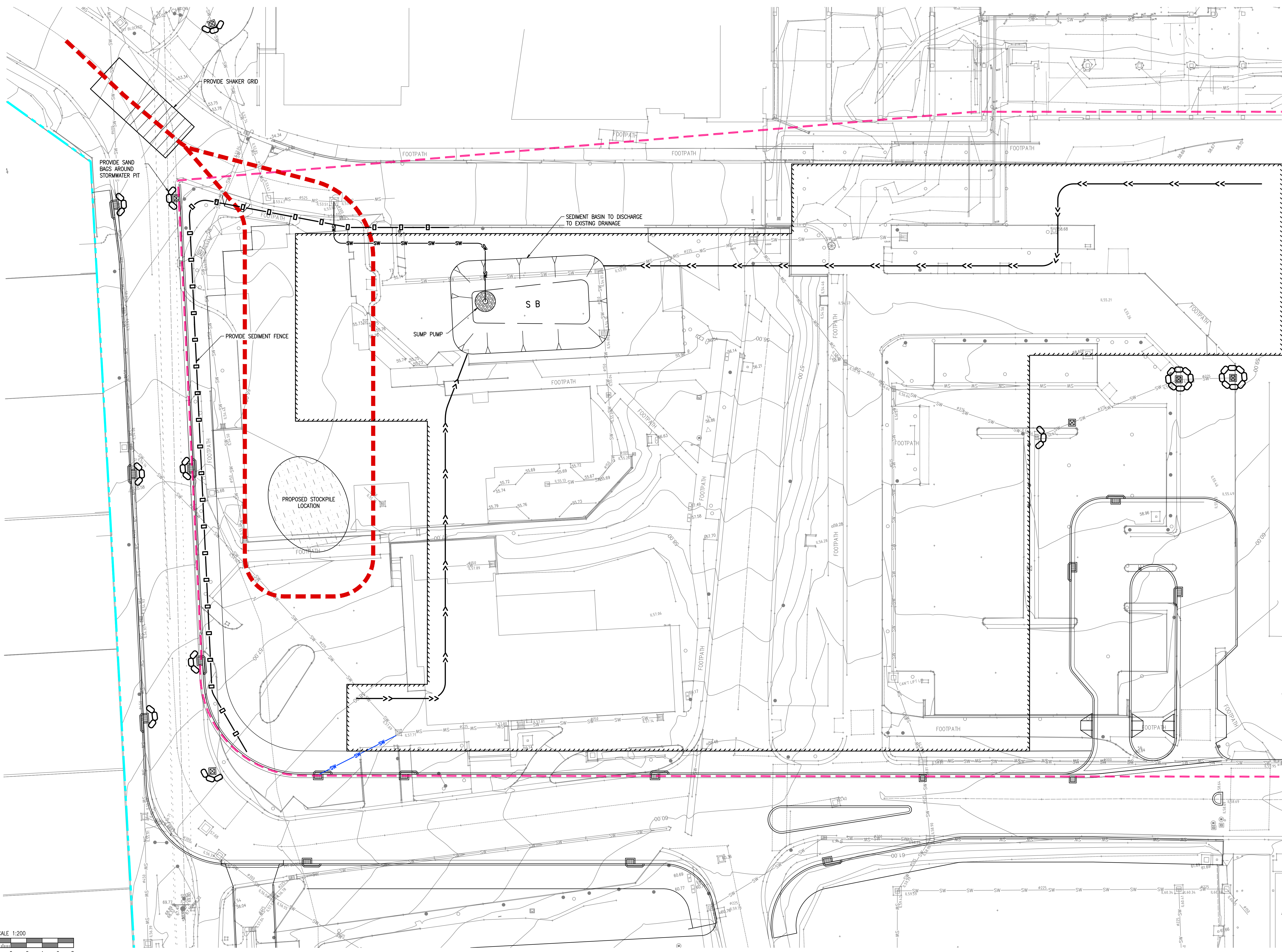

- LEGEND**
- EXISTING SITE BOUNDARY
 - EARLY WORKS EXTENTS
 - PROPOSED BUILDING EXTENTS
 - PROPOSED CONSTRUCTION ACCESS VEHICLE PATH
 - PROPOSED SEDIMENT FENCE
 - PROPOSED EARTH DIVERSION BANK WITH CATCH DRAIN
 - SW PROPOSED TEMPORARY STORMWATER LINE
 -
 - PROVIDE TEMPORARY SANDBAGS AROUND PITS TO EXISTING GRATED PITS DOWNSTREAM OF CONSTRUCTION WORKS.
 -
 - PROPOSED SUMP PUMP
 -
 - SETTLING/SEDIMENTATION BASIN (LANDCOM DETAIL SD6-4)
 -
 - SHAKER GRID AND WASH DOWN FACILITY
 -
 - PROPOSED STOCKPILE

NOTES

REFER BIN2-CV-DG-1110 FOR EROSION & SEDIMENT CONTROL NOTES & DETAILS.

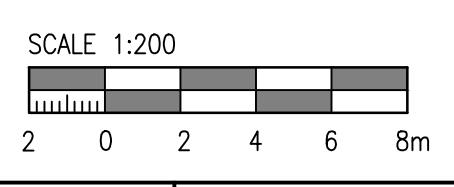

Disclaimer: Robert Bird Group Pty Ltd (RBG) is a registered design (RD) and does not warrant the accuracy, currency or completeness of the information or data the design or drawings or documents are based on. RBG is not responsible for any errors, omissions or delays in providing the information or data the design or drawings or documents are based on. RBG is not responsible for any errors, omissions or delays in providing the information or data the design or drawings or documents are based on. RBG is not responsible for any errors, omissions or delays in providing the information or data the design or drawings or documents are based on.

I/We agree that the information contained in this drawing is the property of Robert Bird Group Pty Ltd (RBG) and shall remain the property of RBG. No part of this drawing may be reproduced, stored in a retrieval system, or transmitted in any form or by any means, electronic, mechanical, photocopying, recording, or by any information storage and retrieval system, without the prior written permission of RBG.

DO NOT SCALE DRAWINGS, USE FIGURED DIMENSIONS

REV.	DATE	BY	APP'D BY	AMENDMENT
1	29.09.15	JAR	CR	ISSUED FOR SSD

CONSULTANT

Date generated: 29.09.15
 Drawn: M. GUNDEL
 Checked: C. WATKINS
 Design: L. RUSSELL
 Approved: C. ROPE

Scale: AS SHOWN

Robert Bird Group
 Structural, Civil & Construction Engineering Consultant
 SYDNEY OFFICE
 Robert Bird Group Pty Ltd
 70 Macquarie Street
 Sydney South, NSW 2000
 Level 11
 155 Cantonment St
 Sydney NSW 2000
 Ph: (02) 8246 3200
 Fax: (02) 8246 3200
 Web Site: www.robertbird.com

PROJECT MANAGER

pwc

MAIN CONTRACTOR

Robert Bird Group

PRINCIPAL

Health Infrastructure

Western Sydney Local Health District

PROJECT

BLACKTOWN MT DRUITT HOSPITAL STAGE 2
 BLACKTOWN CAMPUS: BLACKTOWN ROAD, NSW 2148

CIVIL

DRAWING TITLE
EROSION & SEDIMENT CONTROL PLAN
 BIN2 - EARLY WORKS PACKAGE 2 - GSB BULK EARTHWORKS

SCALE: (B1) AS NOTED
 PROJECT NO: 10684Y
 DRAWING NO: BIN2-CV-DG-1101
 REVISION: 1

FOR INFORMATION

GENERAL NOTES:

- A1. THIS SOIL AND WATER MANAGEMENT PLAN IS TO BE READ IN CONJUNCTION WITH OTHER ENGINEERING PLANS RELATING TO THIS DEVELOPMENT.
- A2. CONTRACTORS WILL ENSURE THAT ALL SOIL AND WATER MANAGEMENT WORKS ARE UNDERTAKEN AS INSTRUCTED IN THIS SPECIFICATION AND CONSTRUCTED FOLLOWING THE LANDCOM – MANAGING URBAN STORMWATER: SOIL AND CONSTRUCTION, 4th EDITION, MAR 2004.
- A3. ALL SUBCONTRACTORS WILL BE INFORMED OF THEIR RESPONSIBILITIES IN REDUCING THE POTENTIAL FOR SOIL EROSION AND POLLUTION TO DOWNSLOPE AREAS.

SEDIMENT BASIN CONSTRUCTION NOTES:

- SB1. REMOVE ALL VEGETATION AND TOPSOIL FROM UNDER THE DAM WALL AND FROM WITHIN THE STORAGE AREA.
- SB2. FORM A CUT OFF TRENCH UNDER THE CENTRELINE OF THE EMBANKMENT 600mm DEEP AND 1200mm WIDE EXTENDING TO A POINT ON THE GULLY WALL ABOVE THE RISER SILL LEVEL.
- SB3. MAINTAIN THE TRENCH FREE OF WATER AND RECOMPACT THE MATERIALS WITH EQUIPMENT TO 95% STANDARD PROCTOR DENSITY.
- SB4. SELECT FILL THAT IS FREE FROM ROOTS, WOOD, ROCK, LARGE STONE OR FOREIGN MATERIAL.
- SB5. PREPARE THE SITE UNDER THE EMBANKMENT BY RIPPING AT LEAST 100mm DEEP TO HELP BOND COMPACTED FILL TO EXISTING SUBSTRATE.
- SB6. SPREAD FILL IN 100mm TO 150mm LAYERS AND COMPACT AT OPTIMUM MOISTURE CONTENT.
- SB7. INSTALL PIPE OUTLET WITH SEEPAGE COLLARS.
- SB8. FORM BATTER GRADES AT 2:1 UPSTREAM AND 3:1 DOWNSTREAM.
- SB9. INSTALL PIPE RISER.
- SB10. CONSTRUCT EMERGENCY SPILLWAY 300mm ABOVE SILL HEIGHT OF RISER PIPE.
- SB11. REHABILITATE STRUCTURE.
- SB12. GEOTEXTILE TO BE REPLACED WITH THE SPECIFIED MATERIAL IF BASIN DOES NOT FREELY DRAIN WITHIN FOUR DAYS.
- SB13. PLACE A "FULL OF SEDIMENT" MARKER TO SHOW WHEN LESS THAN DESIGN CAPACITY OCCURS AND SEDIMENT REMOVAL IS REQUIRED.

SITE MAINTENANCE NOTES:

- SM1. THE CONTRACTOR WILL INSPECT THE SITE AT LEAST WEEKLY AND AT THE CONCLUSION OF EVERY STORM EVENT TO:
 - A) ENSURE THAT DRAINS OPERATE PROPERLY AND TO EFFECT AND NECESSARY REPAIRS.
 - B) REMOVED SPILLED SAND OR OTHER MATERIALS FROM HAZARD AREAS, INCLUDING LANDS CLOSER THAN 5 METRES FROM AREAS OF LIKELY CONCENTRATED OR HIGH VELOCITY FLOWS ESPECIALLY WATERWAYS AND PAVED AREAS.
 - C) REMOVED TRAPPED SEDIMENT WHENEVER THE DESIGN CAPACITY OF THAT STRUCTURES HAS BEEN EXCEEDED.
 - D) ENSURE REHABILITATION LANDS HAVE EFFECTIVELY REDUCED THE EROSION HAZARD TO INITIATE UPGRADING OR REPAIR AS NECESSARY.
 - E) CONSTRUCT ADDITIONAL EROSION AND OR SEDIMENT CONTROL WORKS AS MIGHT BECOME NECESSARY TO ENSURE THE DESIRED PROTECTION IS GIVEN TO DOWNSLOPE LANDS AND WATERWAYS. MAKE ONGOING CHANGES TO THE PLAN WHERE IT PROVES INADEQUATE IN PRACTICE OR IS SUBJECT TO CHANGES IN CONDITIONS ON THE WORK-SITE OR ELSEWHERE IN THE CATCHMENT.
 - F) MAINTAIN EROSION AND SEDIMENT CONTROL STRUCTURES IN A FULLY FUNCTIONING CONDITION UNTIL ALL EARTHWORK ACTIVITIES ARE COMPLETED AND THE SITE IS REHABILITATED.
- SM2. THE CONTRACTOR WILL KEEP A LOGBOOK MAKING ENTRIES AT LEAST WEEKLY, IMMEDIATELY BEFORE FORECAST RAIN AND AFTER RAINFALL. ENTRIES WILL INCLUDE:
 - A) THE VOLUME AND INTENSITY OF ANY RAINFALL EVENTS.
 - B) THE CONDITION OF ANY SOIL AND WATER MANAGEMENT WORKS.
 - C) THE CONDITION OF VEGETATION AND ANY NEED TO IRRIGATE.
 - D) THE NEED FOR DUST PREVENTION STRATEGIES
 THE LOGBOOK WILL BE KEPT ON-SITE AND MADE AVAILABLE TO ANY AUTHORISED PERSON UPON REQUEST. IT WILL BE GIVEN TO THE PROJECT MANAGER AT THE CONCLUSION OF THE WORKS.

SEDIMENT CONTROL NOTES:

- SC1. SEDIMENT FENCES WILL BE INSTALLED AS SHOWN ON THE PLAN AND ELSEWHERE AT THE DISCRETION OF THE SITE CONTRACTOR TO CONTAIN SOIL AS NEAR AS POSSIBLE TO THEIR SOURCE.
- SC2. SEDIMENT FENCES WILL NOT HAVE CATCHMENT AREAS EXCEEDING 900 SQUARE METRES AND HAVE A STORAGE DEPTH OF AT LEAST 0.6 METRES.
- SC3. SEDIMENT REMOVED FROM ANY TRAPPING DEVICES WILL BE RELOCATED WHERE FURTHER POLLUTION TO DOWNSLOPE LANDS AND WATERWAYS CANNOT OCCUR.
- SC4. STOCKPILES ARE NOT TO BE LOCATED WITHIN 5 METERS OF HAZARD AREAS INCLUDING AREAS OF HIGH VELOCITY FLOWS SUCH AS WATERWAYS, PAVED AREAS AND DRIVEWAYS.
- SC5. WATER WILL BE PREVENTED FROM DIRECTLY ENTERING THE PERMANENT DRAINAGE SYSTEM UNLESS THE CATCHMENT AREA HAS BEEN PERMANENTLY LANDSCAPED AND/OR WATER HAS BEEN TREATED BY AN APPROVED DEVICE.
- SC6. TEMPORARY SEDIMENT TRAPS WILL REMAIN IN PLACE UNTIL AFTER THE LANDS THEY ARE PROTECTING ARE COMPLETELY REHABILITATED.
- SC7. ACCESS TO SITES SHOULD BE STABILIZED TO REDUCE THE LIKELIHOOD OF VEHICLES TRACKING SOIL MATERIALS ONTO PUBLIC ROADS AND ENSURE ALL-WEATHER ENTRY/EXIT.

LAND DISTURBANCE NOTES:

- LD1. ACCESS AREAS ARE TO BE LIMITED TO A MAXIMUM WIDTH OF 10 METERS THE SITE MANAGER WILL DETERMINE AND MARK THE LOCATION OF THESE ZONES ON-SITE. ALL SITE WORKERS WILL CLEARLY RECOGNIZE THOSE BOUNDARIES THAT, WHERE APPROPRIATE, ARE IDENTIFIED WITH A BARRIER FENCING (UPSLOPE) AND SEDIMENT FENCING (DOWNSLOPE) OR SIMILAR MATERIALS.
- LD2. ENTRY TO LANDS NOT REQUIRED FOR CONSTRUCTION OR ACCESS IS PROHIBITED EXCEPT FOR ESSENTIAL THINNING OF PLANT GROWTH.
- LD3. WORKS ARE TO PROCEED IN THE FOLLOWING SEQUENCE:
 - A) INSTALL ALL BARRIER AND SEDIMENT FENCING WHERE SHOWN ON THE PLAN.
 - B) CONSTRUCT THE STABILISED SITE ACCESS.
 - C) CONSTRUCT DIVERSION DRAINS AS REQUIRED.
 - D) INSTALL MESH AND GRAVEL INLETS FOR ANY ADJACENT KERB INLETS.
 - E) INSTALL GEOTEXTILE INLET FILTERS AROUND ANY ON-SITE DROP INLET PITS.
 - F) CLEAR SITE AND STRIP AND STOCKPILE TOPSOIL IN LOCATIONS SHOWN ON THE PLAN.
 - G) UNDERTAKE ALL ESSENTIAL CONSTRUCTION WORKS ENSURING THAT ROOF AND/OR PAVED AREA STORMWATER SYSTEMS ARE CONNECTED TO PERMANENT DRAINAGE AS SOON AS PRACTICABLE.
 - H) GRADE LOT AREAS TO FINAL GRADES AND APPLY PERMANENT STABILISATION (LANDSCAPING) WITHIN 20 DAYS OF COMPLETION OF CONSTRUCTION WORKS.
 - I) REMOVE TEMPORARY EROSION CONTROL MEASURES AFTER THE PERMANENT LANDSCAPING HAS BEEN COMPLETED.
- LD4. ENSURE THAT SLOPE LENGTHS DO NOT EXCEED 80 METRES WHERE PRACTICABLE. SLOPE LENGTHS ARE DETERMINED BY SILTATION FENCING AND CATCH DRAIN SPACING.

SOIL EROSION CONTROL NOTES:

- SE1. EARTH BATTERS WILL BE CONSTRUCTED WITH AS LOW A GRADIENT AS PRACTICABLE AND NO STEEPER THAN THAT RECOMMENDED IN THE FUTURE GEOTECHNICAL REPORT.
- SE2. ALL WATERWAYS, DRAINS, SPILLWAYS AND THEIR OUTLETS WILL BE CONSTRUCTED TO BE STABLE IN AT LEAST THE 1:20 YEAR ARI, TIME OF CONCENTRATION STORM EVENT.
- SE3. WATERWAYS AND OTHER AREAS SUBJECT TO CONCENTRATED FLOWS AFTER CONSTRUCTION ARE TO HAVE A MAXIMUM GROUND COVER C-FACTOR OF 0.05 (70% GROUND COVER) WITHIN 10 WORKING DAYS FROM COMPLETION OF FORMATION. FOOT AND VEHICULAR TRAFFIC WILL BE PROHIBITED IN THESE AREAS.
- SE4. STOCKPILES AFTER CONSTRUCTION ARE TO HAVE A MAXIMUM GROUND-COVER C-FACTOR OF 0.1% (60% GROUND-COVER) WITHIN 10 WORKING DAYS FROM COMPLETION OF FORMATION.
- SE5. ALL LANDS, INCLUDING WATERWAYS AND STOCKPILES DURING CONSTRUCTION ARE TO HAVE A MAXIMUM GROUND COVER C-FACTOR OF 0.15 (50% GROUND COVER) WITHIN 20 WORKING DAYS FROM INACTIVITY EVEN THOUGH WORKS MAY CONTINUE LATER.
- SE6. PERMANENT REHABILITATION OF LANDS AFTER CONSTRUCTION WILL ACHIEVE A GROUND-COVER C-FACTOR OF LESS THAN 0.1 AND LESS THAN 0.05 WITHIN 60 DAYS. NEWLY PLANTED LANDS WILL BE WATERED REGULARLY UNTIL AN EFFECTIVE COVER IS ESTABLISHED AND PLANTS ARE GROWING VIGOROUSLY. FOLLOW-UP SEED AND FERTILISER WILL BE APPLIED AS NECESSARY.

WASTE CONTROL NOTES:

- WC1. ACCEPTABLE BINS WILL BE PROVIDED FOR ANY CONCRETE AND MORTAR SLURRIES, PAINTS, ACID WASHING, LIGHTWEIGHT WASTE MATERIALS AND LITTER. CLEARANCE SERVICES WILL BE PROVIDED AT LEAST WEEKLY. DISPOSAL OF WASTE WILL BE IN A MANNER APPROVED BY THE SITE CONTRACTOR.
- WC2. ALL POSSIBLE POLLUTANT MATERIALS ARE TO BE STORED WELL CLEAR OF ANY POORLY DRAINED AREAS, FLOW PRONE AREAS, STREAMBANKS, CHANNELS AND STORMWATER DRAINAGE AREAS. STORE SUCH MATERIALS IN A DESIGNATED AREA UNDER COVER WHERE POSSIBLE AND WITHIN CONTAINMENT BUNDS.
- WC3. ALL SITE STAFF AND SUBCONTRACTORS ARE TO BE INFORMED OF THEIR OBLIGATION TO USE WASTE CONTROL FACILITIES PROVIDED.
- WC4. ANY DE-WATERING ACTIVITIES ARE TO BE CLOSELY MONITORED TO ENSURE THAT WATER IS NOT POLLUTED BY SEDIMENT, TOXIC MATERIALS OR PETROLEUM PRODUCTS.
- WC5. PROVIDE DESIGNATED VEHICULAR WASHDOWN AND MAINTENANCE AREAS WHICH ARE TO HAVE CONTAINMENT BUNDS.

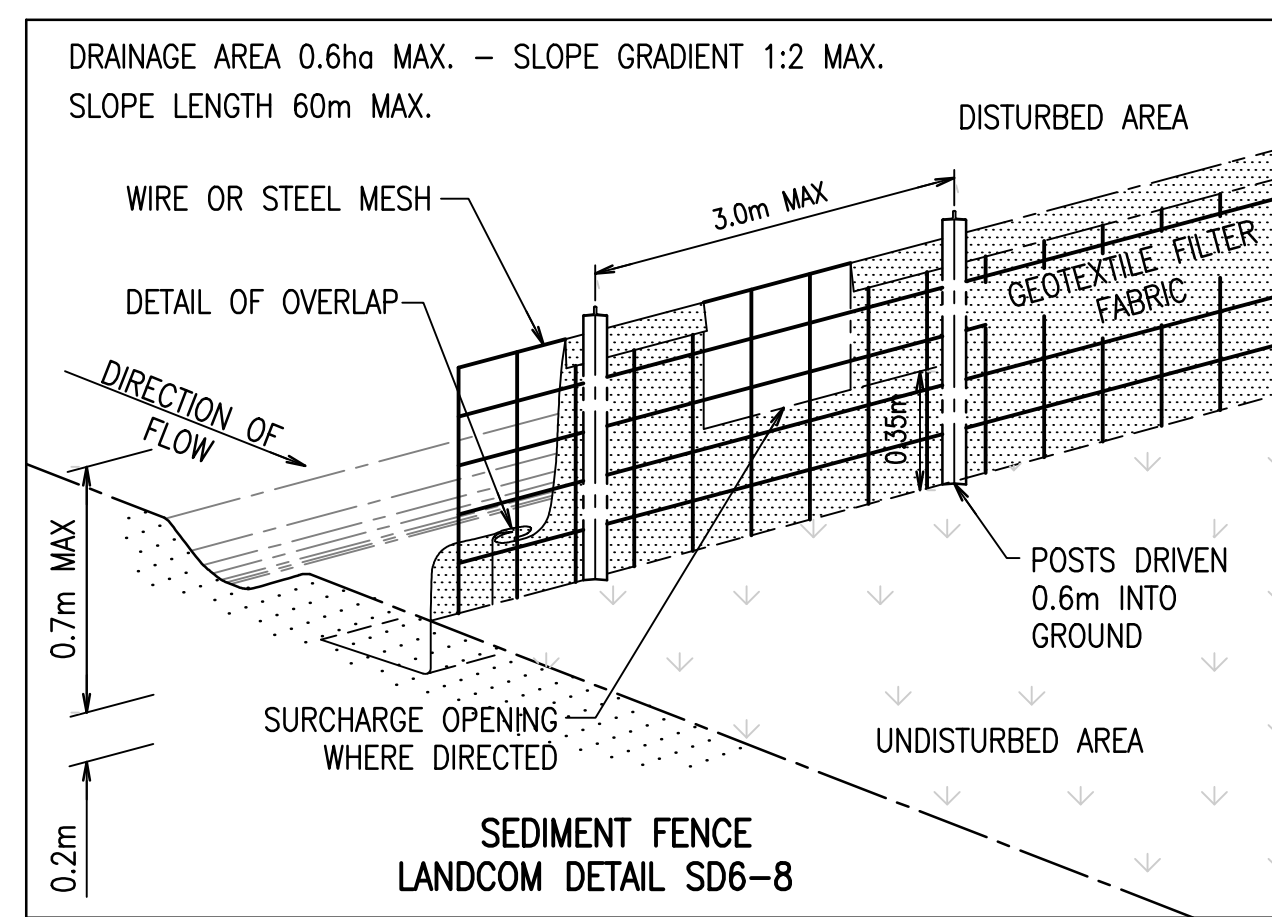
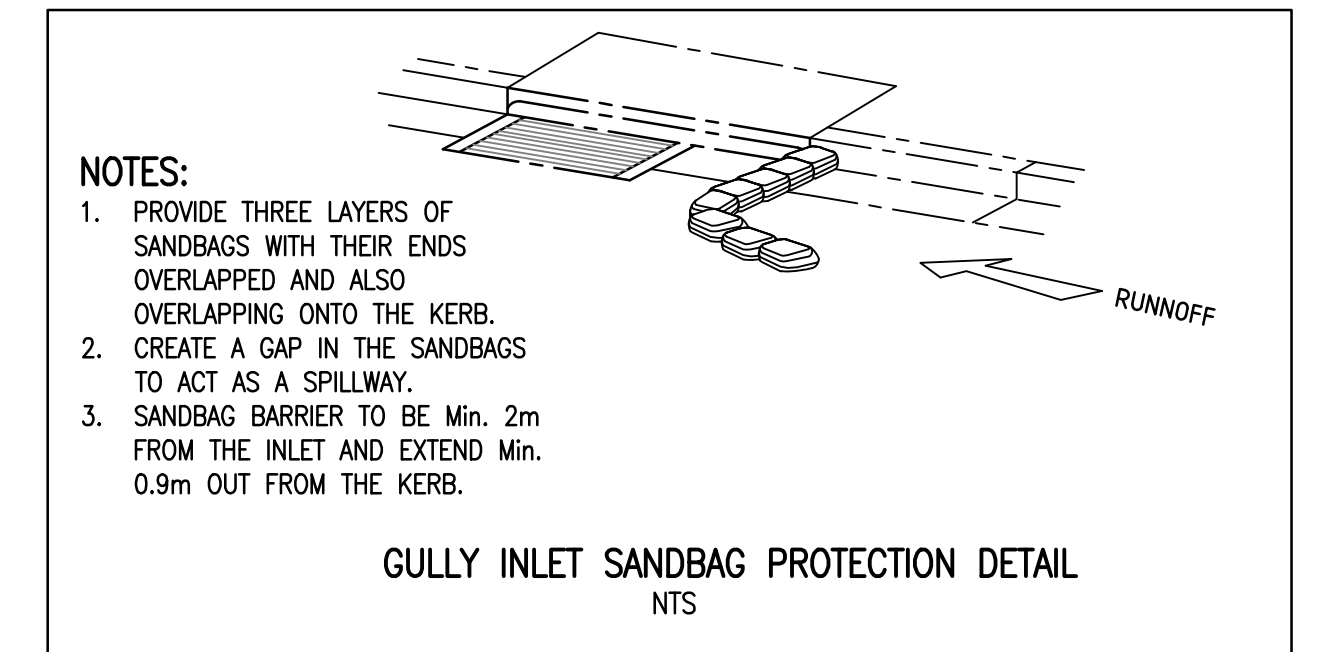
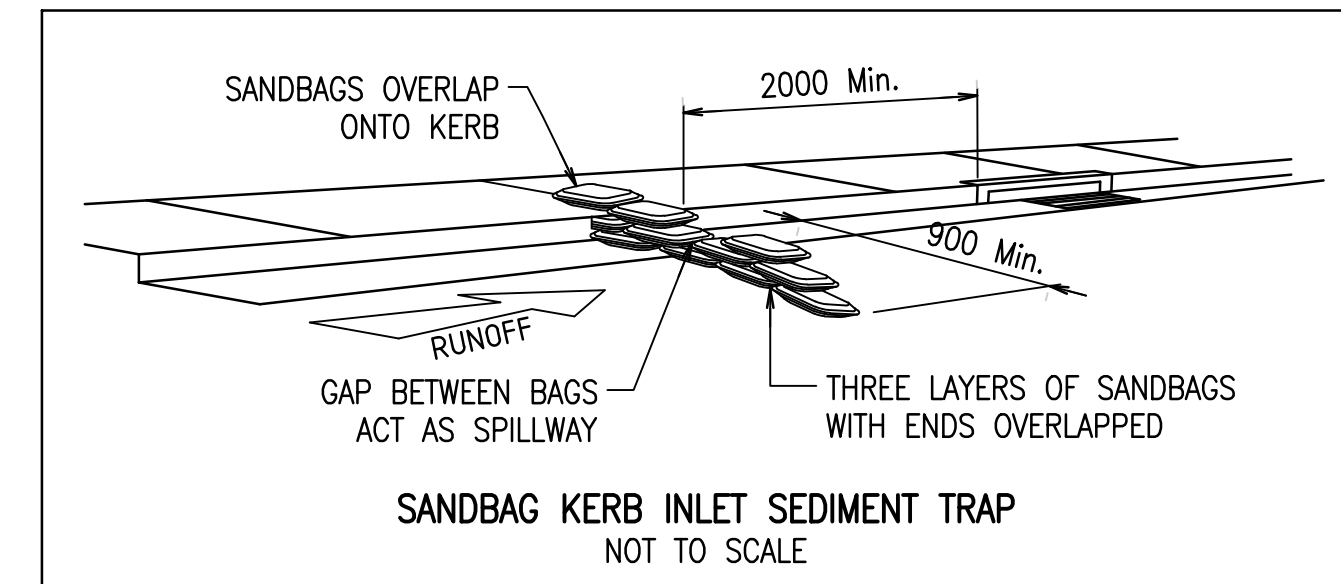
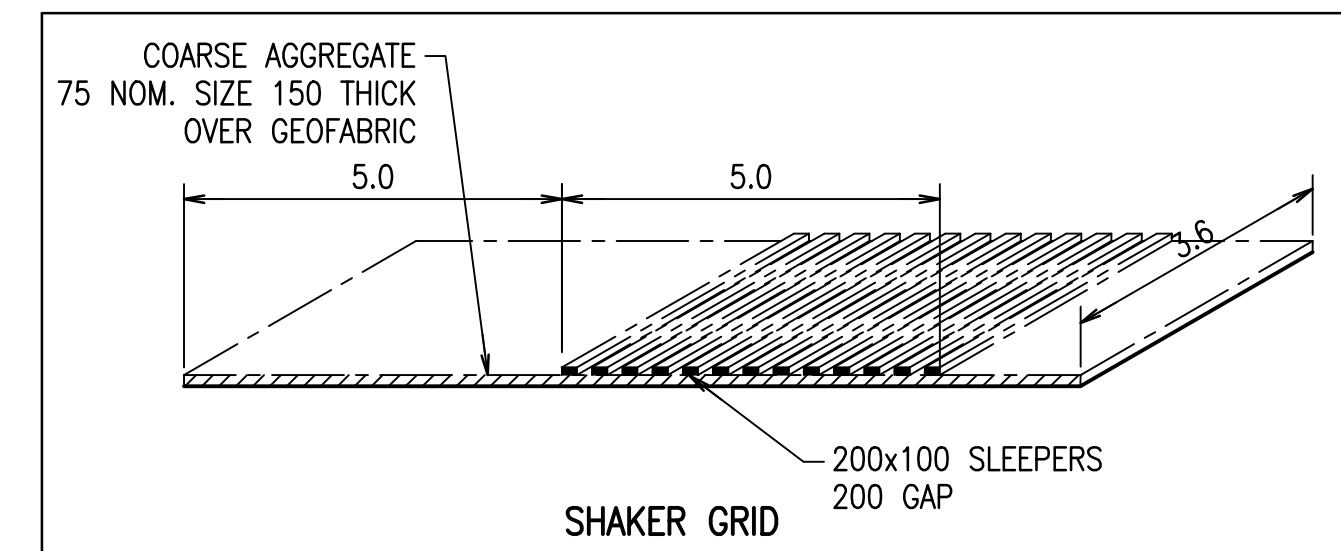

INSTALLATION

1. EXCAVATE A TRENCH 200mm DEEP.
2. DRIVE POSTS 500-700mm INTO GROUND AT A MAXIMUM SPACING OF 3.0m CENTRES.
3. PLACE AND FIX SUPPORT MESH (F52) TO POST.
4. LAY BIDIM GEOTEXTILE (SF 2000) AGAINST THE SUPPORT MESH AND FIX BY TIE WIRE, STAPLES OR HOG RINGS.
5. PLACE BIDIM IN TRENCH AND BACKFILL WITH SOIL.

NOTE: POSITION OF SEDIMENT FENCE AS DIRECTED BY MANAGING CONTRACTOR. FENCE TO REMAIN IN PLACE UNTIL EXCAVATION IS BELOW FOOTPATH LEVEL. PROVIDE 2mx2m TURFED AREA ON DOWNSTREAM SIDE OF FENCE AT SURCHARGE OPENINGS.

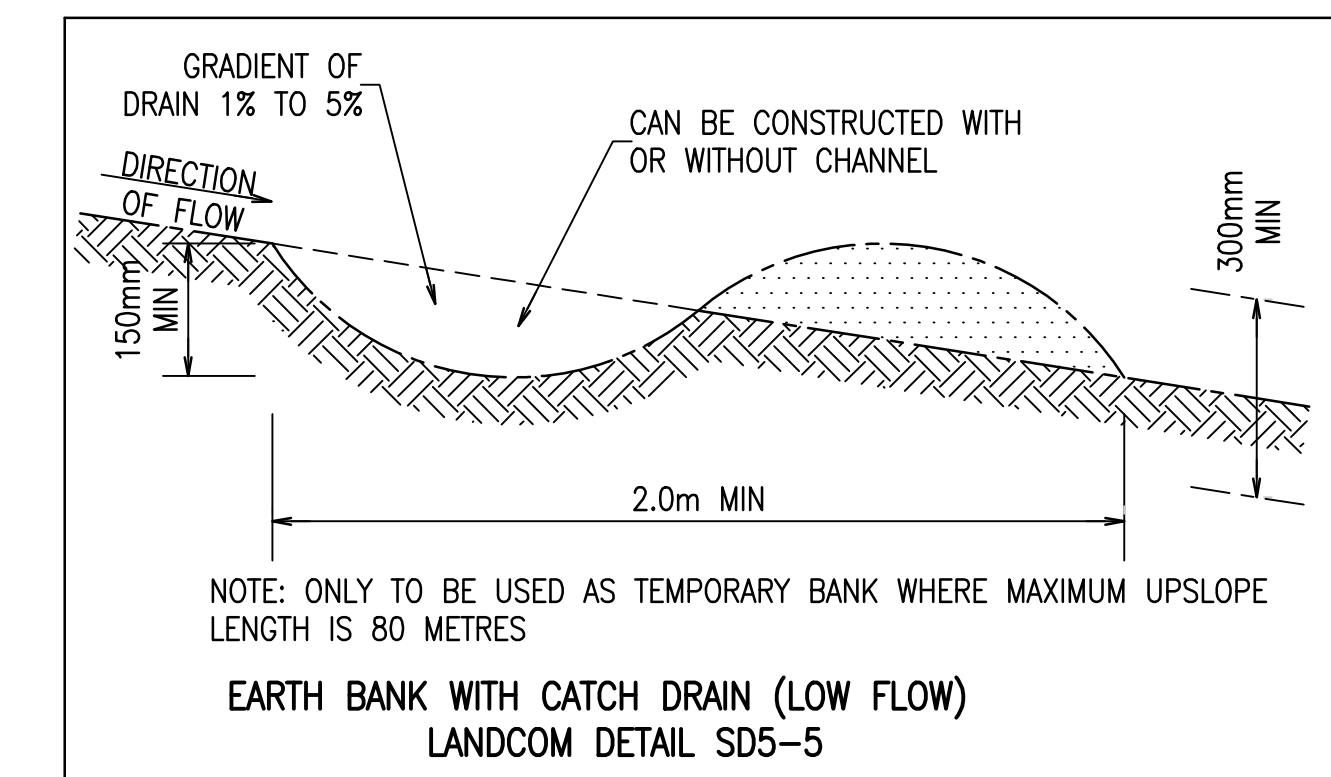
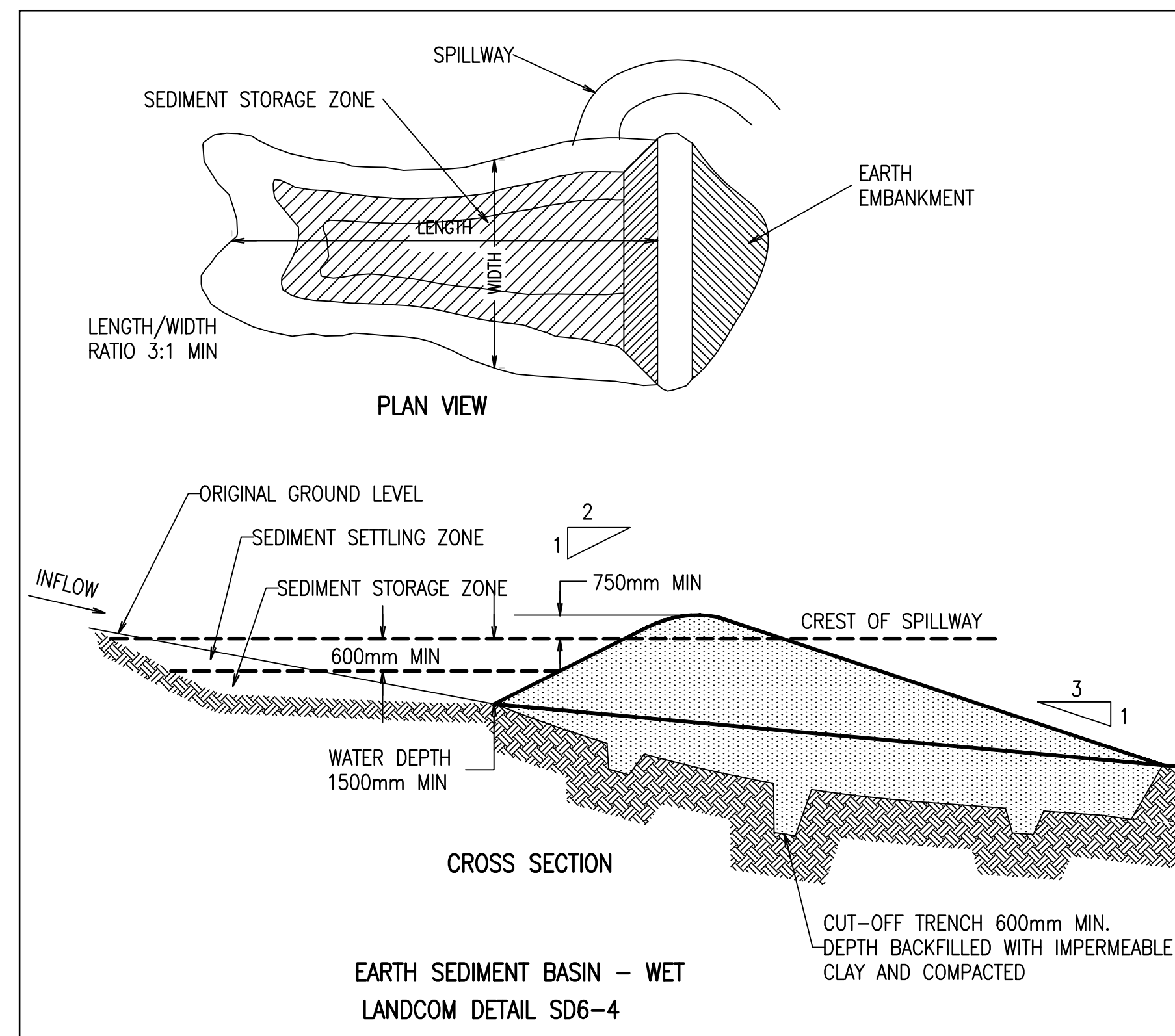

FOR INFORMATION

Disclaimer: Robert Bird Group Pty Ltd (RBG) does not warrant, represent or guarantee the accuracy, completeness or reliability of any information or data supplied or received by any third party. RBG is not responsible for any loss or damage to any person or property arising from the use of any information or data supplied or received by any third party. RBG is not responsible for any loss or damage to any person or property arising from the use of any information or data supplied or received by any third party. RBG is not responsible for any loss or damage to any person or property arising from the use of any information or data supplied or received by any third party.

DO NOT SCALE DRAWINGS, USE FIGURED DIMENSIONS	
REV.	DATE
1	29.09.15

ISSUED FOR: SD	DATE: 29.09.15	BY: IAR	APPD BY: CR
AMENDMENT	BY: IAR	APPD BY: CR	P.DOR.

Date generated	Drawn	Design
29.09.15	M.CANAL	L.RISSELL
	Checked	Approved
	C.MATE	C.ROPE

Scale	AS SHOWN
-------	----------

CONSULTANT

Structural, Civil & Construction Engineering Consultant

Robert Bird Group

SYDNEY OFFICE
 Robert Bird Group Pty Ltd
 270 Macquarie Street
 Sydney, NSW 2000
 Level 11
 155 Cumberland St
 Sydney NSW 2000
 Ph: (02) 8246 3200
 Fax: (02) 8246 3200

PROJECT MANAGER

pwc

MAIN CONTRACTOR

NSW Health Infrastructure

PRINCIPAL

NSW Health Western Sydney Local Health District

PROJECT

BLACKTOWN MT DRUITT HOSPITAL STAGE 2

BLACKTOWN CAMPUS: BLACKTOWN ROAD, NSW 2148

CIVIL	
DRAWING TITLE	
EROSION & SEDIMENT CONTROL NOTES & DETAILS	
SCALE: (B1) AS NOTED	DRAWING NO: BIN2-CV-DG-1110
PROJECT NO: 10684Y	REVISION: 1

LEGEND

- EXISTING SITE BOUNDARY
- - - - - EARLY WORKS EXTEND
- PROPOSED BUILDING EXTEND
- - - - - PROPOSED MINOR CONTOUR
- - - - - PROPOSED MAJOR CONTOUR
- - - - - EXISTING MAJOR CONTOUR
- - - - - EXISTING MAJOR CONTOUR
- - - - - PROPOSED BULK EARTHWORKS PAD OUTLINE
- BEL 54.55 PROPOSED BULK EARTHWORKS LEVEL

DEPTH RANGE VALUES

Lower_value	Upper_value	Colour
-9.99	to -10	m
-10	to -9.5	m
-9.5	to -9	m
-9	to -8.5	m
-8.5	to -8	m
-8	to -7.5	m
-7.5	to -7	m
-7	to -6.5	m
-6.5	to -6	m
-6	to -5.5	m
-5.5	to -5	m
-5	to -4.5	m
-4.5	to -4	m
-4	to -3.5	m
-3.5	to -3	m
-3	to -2.5	m
-2.5	to -2	m
-2	to -1.5	m
-1.5	to -1	m
-1	to -0.5	m
-0.5	to 0.0	m

- NOTES**
- BULK EARTHWORKS ANALYSIS DOES NOT ACCOUNT FOR TOPSOIL, EXISTING SLABS OR BULKING FACTORS.
 - TEMPORARY CONSTRUCTION BATTERS ARE NOT ACCOUNTED FOR.
 - BELs ASSUME A 200mm SLAB DEPTH AND 50mm BUNDLING LAYER FROM FINISHED FLOOR LEVELS.

ESTIMATED CUT VOLUME = 33,788m³
ESTIMATED FILL VOLUME = 0m³

PRINT DRAWING IN COLOUR

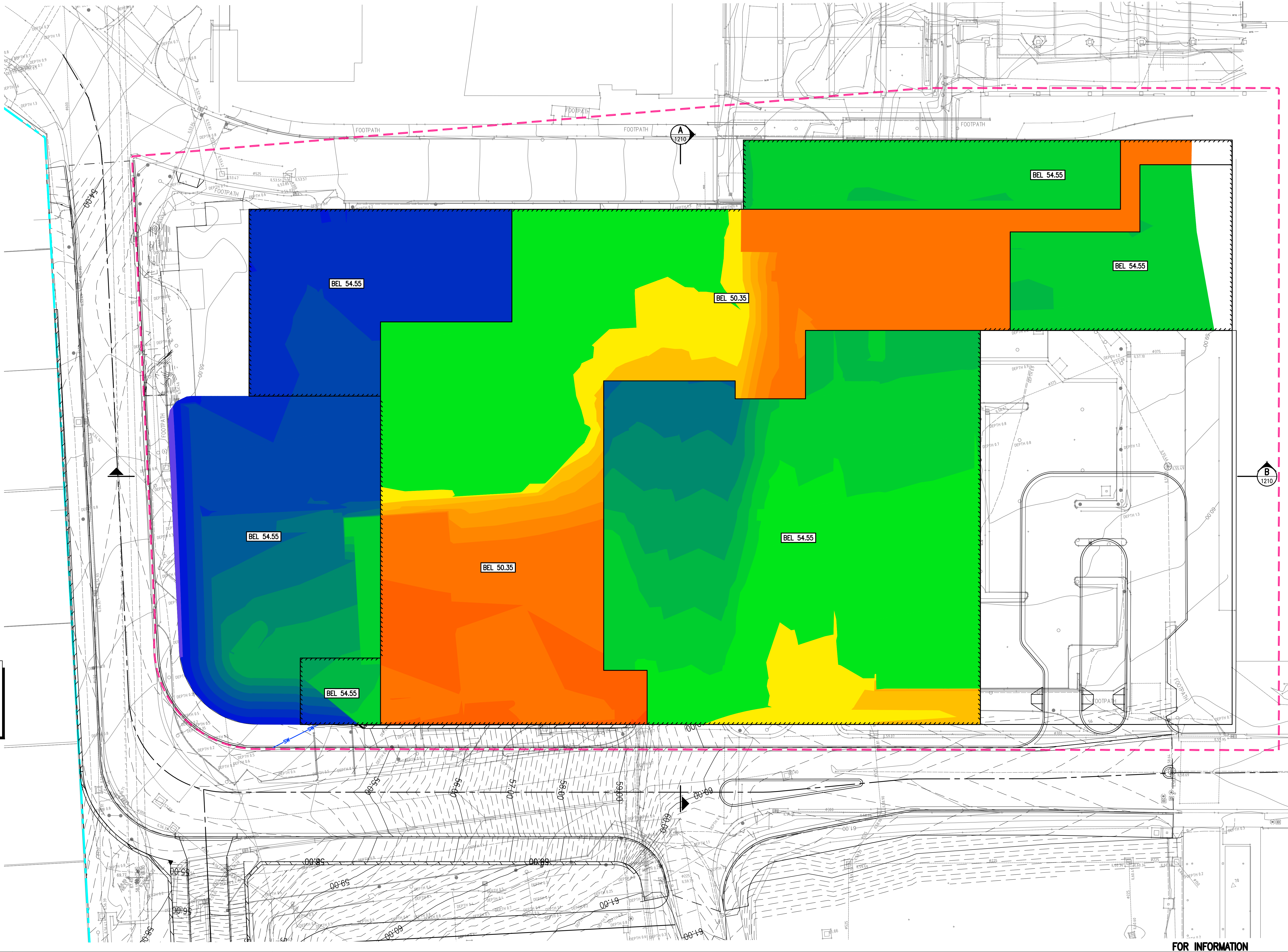
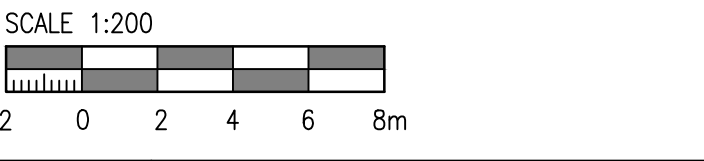

FOR INFORMATION

DO NOT SCALE DRAWINGS, USE FIGURED DIMENSIONS

REV.	DATE	BY	APP'D BY	AMENDMENT
1	29.09.15	LAR	CR	ISSUED FOR SSD

Scale AS SHOWN

CONSULTANT
Structural, Civil & Construction Engineering Consultant
Robert Bird Group
SYDNEY OFFICE
Robert Bird Group Pty Ltd
70 Macquarie Street
Sydney South, NSW 2000
Level 11
155 Cumberland St
Sydney NSW 2000
Ph: (02) 8246 3200
Fax: (02) 8246 3200
Web Site: www.robertbird.com

PROJECT MANAGER
M. GUNDEL
Checked
C.MATE

MAIN CONTRACTOR
pwc

PRINCIPAL
NSW Health Infrastructure
NSW Health Western Sydney Local Health District

PROJECT
BLACKTOWN MT DRUITT HOSPITAL STAGE 2
BLACKTOWN CAMPUS: BLACKTOWN ROAD, NSW 2148

CIVIL
DRAWING TITLE
BIN2 - EARLY WORKS PACKAGE 2 - CSB BULK EARTHWORKS
BULK EARTHWORKS PLAN
SCALE (B1) AS NOTED
PROJECT No: 10684Y

DRAWING No: BIN2-CV-DG-1201
REVISION
1

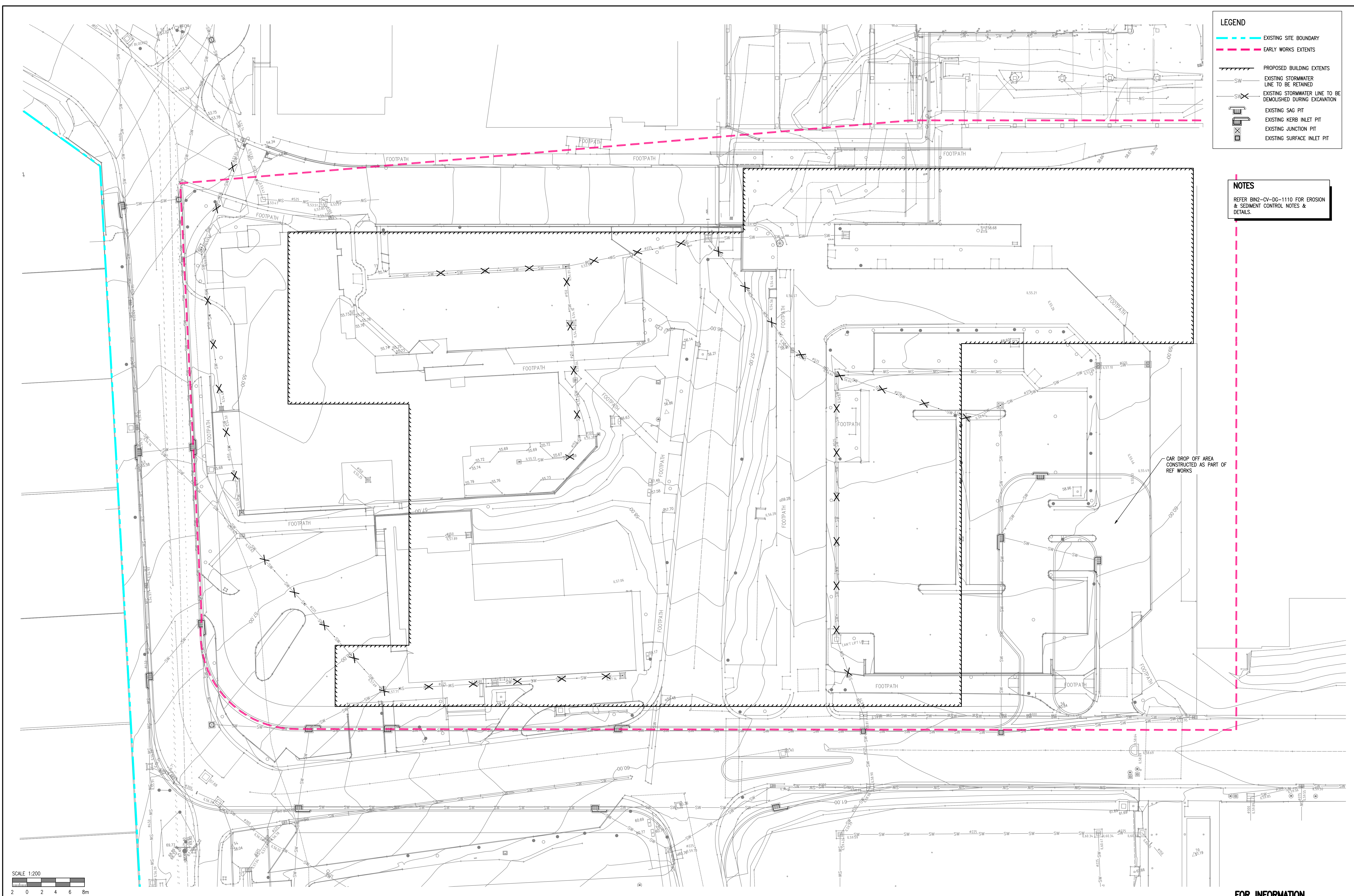

LEGEND

- EXISTING SITE BOUNDARY
- EARLY WORKS EXTENTS
- PROPOSED BUILDING EXTENTS
- EXISTING STORMWATER LINE TO BE RETAINED
- EXISTING STORMWATER LINE TO BE DEMOLISHED DURING EXCAVATION
- X EXISTING SAG PIT
- K EXISTING KERB INLET PIT
- J EXISTING JUNCTION PIT
- I EXISTING SURFACE INLET PIT

NOTES

REFER BIN2-CV-DG-1110 FOR EROSION & SEDIMENT CONTROL NOTES & DETAILS.

CAR DROP OFF AREA
CONSTRUCTED AS PART OF
REF WORKS

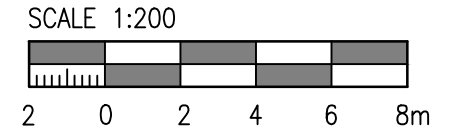

FOR INFORMATION

Disclaimer: Robert Bird Group Pty Ltd (RBG) is not responsible for any errors or omissions in this drawing. RBG does not warrant the accuracy, completeness or reliability of any information or data supplied or referred to in this drawing. RBG is not responsible for any damage or loss of any kind, including but not limited to, direct, indirect, consequential or otherwise, arising from the use of this drawing. RBG is not responsible for any damage or loss of any kind, including but not limited to, direct, indirect, consequential or otherwise, arising from the use of this drawing. RBG is not responsible for any damage or loss of any kind, including but not limited to, direct, indirect, consequential or otherwise, arising from the use of this drawing.

I/We agree that the information contained in this drawing is for the use of the client only and is not to be used for any other purpose without the prior written permission of Robert Bird Group Pty Ltd.

DO NOT SCALE DRAWINGS, USE FIGURED DIMENSIONS

REV.	DATE	BY	APP'D BY	AMENDMENT
1	29.09.15	AR	CR	ISSUED FOR SSD

Date generated	Drawn	Design
29.09.15	M. GUNDEL	L. RUSSELL
	Checked	Approved
	C. NITE	C. ROPE

Scale AS SHOWN

CONSULTANT

Structural, Civil & Construction Engineering Consultant

Robert Bird Group

SYDNEY OFFICE
 Robert Bird Group Pty Ltd
 70 Macquarie Street
 Sydney South, NSW 2000
 Level 11
 155 Clarence Street
 Sydney NSW 2000
 Ph. (02) 8246 3200
 Fax (02) 8246 3200
 Web Site: www.robertbird.com

PROJECT MANAGER

MAIN CONTRACTOR

PRINCIPAL

PROJECT

BLACKTOWN MT DRUITT HOSPITAL STAGE 2

BLACKTOWN CAMPUS: BLACKTOWN ROAD, NSW 2148

CIVIL

DRAWING TITLE
 BIN2 - EARLY WORKS PACKAGE 2 - GSB BULK EARTHWORKS

GENERAL ARRANGEMENT PLAN

SCALE (B1) AS NOTED
 PROJECT NO: 10684Y

DRAWING NO:
 BIN2-CV-DG-1301

REVISION
 1

FOR INFORMATION

NSW Health Infrastructure
 Western Sydney Local Health District