



van der meer

INTEGRATED WATER CYCLE MANAGEMENT PLAN

PROJECT PLUTO

132 McCredie Road,

Guildford West NSW 2161

Document Control Record

Prepared by:	Vahid Bazzaz
Reviewed by:	Hary Budhi
Approved by:	Andrew Wallis
Position:	Associate Director
Signed:	
Date:	12/03/2025
Job No.	SY242-012

REVISION STATUS

Revision	Description of Revision	Date	Issued By:
A	SSDA	12/03/2025	Vahid Bazzaz

Recipients are responsible for eliminating all superseded documents in their possession.

van der Meer Consulting (NSW)

ABN 56 158 266 301

Level 6, 39 Chandos Street,
ST LEONARDS, NSW 2065

Telephone: +61 2 9436 0433

This document and its contents are intended for the addressee only and contains opinions held by the Author based on material available at the time and expresses those opinions for the purposes of consideration by the Addressee and not for general publication without written consent.



TABLE OF CONTENTS

EXECUTIVE SUMMARY	4
1. INTRODUCTION	5
1.1 THE SITE	7
1.2 STAGING	7
2. STORMWATER QUANTITY CONTROL.....	9
2.1 OBJECTIVES AND CONTROL.....	9
2.2 EXISTING DRAINAGE SYSTEM	9
2.3 PROPOSED DRAINAGE SYSTEM.....	9
2.4 ON-SITE STORMWATER DETENTION (OSD)	11
3. STORMWATER QUALITY CONTROL	12
3.1 OBJECTIVE AND CONTROL	12
3.2 PROPOSED STORMWATER QUALITY TREATMENT MEASURES.....	12
3.3 MUSIC RESULTS	13
3.4 STORMWATER DRAINAGE MAINTENANCE.....	14
4. WATER	15
4.1 RECYCLED WATER.....	15
4.2 WATER CONNECTION STRATEGY	16
5. SEWER.....	17
5.1 FIRE WATER	17
5.2 SEWER CONNECTION STRATEGY	17
6. WATER BALANCE	19
6.1 WATER SUPPLY	19
6.2 WATER DEMAND.....	19
6.3 WATER DISCHARGE.....	20
6.4 WATER BALANCE SUMMARY	20
7. CONCLUSION	21
APPENDIX A- CIVIL PLANS.....	22
APPENDIX B- WATER QUALITY DEVICE DETAILS	23



EXECUTIVE SUMMARY

This Integrated Water Cycle Management Plan (IWCMP) has been prepared by van der Meer Consulting to accompany a State Significant Development Application (SSDA) for the construction and ongoing operation of a data centre facility at 132 McCredie Road, Guildford West NSW 2161, in the Cumberland Council Local Government Area (**LGA**). The site is legally described as Lot 1 in DP596315. This report has been prepared to address the Secretary's Environmental Assessment Requirements (**SEARs**) issued for the Project Pluto Data Centre (SSD-69223466) dated 4 April 2024.

This report concludes that the proposed data centre is suitable and warrants approval subject to the implementation of the following mitigation measures.

- Stormwater drainage

Following the implementation of the above mitigation measures, the remaining impacts are appropriate.



1. Introduction

A State Significant Development Application (**SSDA**) has been prepared in support of a proposed data centre at 132 McCredie Road, Guildford West NSW 2161. The site is zoned E4 General Industrial and has a road frontage to McCredie Road. The developable site area is approximately 71,710 sqm.

The proposed development comprises:

- Site preparation works including bulk excavation and removal of existing hard standing and structures on the site, tree and vegetation clearing, and bulk earthworks;
- Construction, fit out and operation of a data centre with an approximate building height of 25.77m and total gross floor area of approximately 29,444 m² comprising:
 - At-grade parking for 53 car parking spaces and 2 accessible car parking spaces
 - Two (2) loading dock spaces.
 - Two (2) levels of technical data hall floor space with incorporating a total of nine (9) data halls
 - Ancillary office space
- Provision of required utilities, including:
 - Fuel storage
 - Two (2) Switch-rooms
 - Four (4) industrial water storage tanks
- Vehicle entry and egress driveways located along McCredie Road
- Internal access road
- Associated landscaping and site servicing
- Installation of services and drainage infrastructure.



This report has been prepared to address the Secretary’s Environmental Assessment Requirements (**SEARs**) and accompanying cover letter issued for the Project Pluto Data Centre (SSD-69223466) dated 4 April 2024.

Specifically, this report has been prepared to respond to the SEARs requirement issued below.

Table 1 : SEARs for civil engineering

Item	Description of Requirement	Section reference
14	Water Management Provide an Integrated Water Management Plan for the development that:	
	<ul style="list-style-type: none"> Is prepared in consultation with the local council and any other relevant drainage authority. 	ALL
	<ul style="list-style-type: none"> Outlines the water-related servicing infrastructure required by the development (informed by the anticipated annual and ultimate increase in servicing demand) and evaluates opportunities to reduce water demand (such as recycled water provision). 	Section 4
	<ul style="list-style-type: none"> Details the proposed drainage design for the site including on-site detention facilities, water quality measures and the nominated discharge points, on-site sewage management, and measures to treat, reuse or dispose of water. 	Section 2 & 3
	<ul style="list-style-type: none"> Details the proposed drainage design (stormwater and wastewater) for the site including any on-site treatment, reuse and detention facilities, water quality management measures, and nominated discharge points. 	Section 2, 3 & 5
	<ul style="list-style-type: none"> Demonstrates compliance with the local council or other drainage or water authority requirements and avoids adverse downstream impacts. 	Section 2, 3 & 4
	Where water and drainage infrastructure works are required that would be handed over to the local council, or other drainage or water authority, provide full hydraulic details and detailed plans and specification of proposed works that have been prepared in consultation with, and comply with the relevant standards, the local council or other drainage or water authority.	ALL

1.1 The Site

The site is located on Gandangara Land and is in the Smithfield Industrial Area within the Cumberland Local Government Area (LGA). It is bounded by McCredie Road to the north.

The front part of the site adjoins the Guildford Transmission Substation, which is located immediately to the east and fronts onto McCredie Road. Other industrial uses are located further east, with residential properties beyond.

The Guildford West Sports Ground, which comprises several playing fields, is located to the south of the Guildford Transmission Substation. The playing fields bound the southern part of the site to the east. The playing fields / public recreation area also about the southern boundary of the site.

Prospect Creek is located to the south of the public recreation area and is zoned C2 Environmental Protection. The area to the south of Prospect Creek is predominately characterised by low density single storey residential housing.

The site is located in the south eastern corner of the Smithfield Industrial Estate and is within close proximity of the Cumberland Highway (A28) and M4 and M7 motorways, which provide access to Sydney CBD, western Sydney and the south. A range of large format industrial uses are located to the west and north west of the site. The Smithfield Industrial Estate extends across the A28 to Gipps Road (approximately 3km west of the site). It forms part of the broader Smithfield Wetherill Park industrial area, which is one of the largest of its kind in the Southern Hemisphere and makes a significant contribution to the New South Wales and Australian economies.

The site has a net developable area of 71,710 sqm and is currently vacant. It previously operated as a Castrol Lubricants facility. However, the majority of the site has now been cleared and subject to category 1 remediation works. A single storey office building is located on the northern portion of the site fronting McCredie Road. The building is vacant.

1.2 Staging

The proposal seeks consent for development to be constructed and operated in two phases to reflect the staged availability power supply. The proposed stages involve the following:

Stage 1: Construction of the main data centre building as well as the car park, perimeter access road, site access/exit driveways and landscaping. Stage one will involve the fit-out and operation of five of the 9 proposed data halls at levels 1 and 2 as well as the associated electrical rooms, generators, storage and office rooms.

Stage 2: Completion of the ultimate development scheme involving the extension of the building to the south with an additional four data halls, associated electrical rooms and generators, and associated landscaping and external works. The electrical substations will also be constructed in the north of the site during this phase.



2. Stormwater Quantity Control

2.1 Objectives and Control

Cumberland City Council has a stormwater disposal policy and engineering design guideline to all developments within the Cumberland City Council Local Government Area.

The following guidelines were informed in the stormwater design:

- Cumberland City Council DCP Part G - provides guidelines - objectives and controls for people who wish to carry out Miscellaneous Development within Cumberland City Council. Controls
- Cumberland City Council Local Environmental Plan 2021
- Upper Parramatta River Catchment Trust (UPRCT) 4th Edition - drainage system to comply with UPRCT as required by Cumberland City Council DCP Part G, Section 2.4
- Australian Rainfall and Runoff (2019) - Engineers Australia (EA) published the Australian Rainfall and Runoff – A Guide to Flood Estimation which provided the information and approach for hydrology and stormwater management. It contains information to estimate the stormwater runoff, design storm events, and design method for the urban stormwater drainage systems.

2.2 Existing Drainage System

Information regarding existing stormwater assets was available from the Utilities Survey, Site Survey and Satellite imagery. The existing stormwater drainage pipework within the site is being removed. There is a council stormwater line running along the eastern and southeast border of the site. The survey completed including as listed below

- Existing 1350mm diameter existing stormwater pipe in approximately 470m length
- Existing stormwater grated and junction pits
- Approximate 2.5m width of easement above the existing and along the eastern boundary

Refer to the drainage survey for further details about the existing pipe routes levels, length, and pipes sizes (LTS Survey plans ref num. 51810 005DT, dated 2024.02.13)

2.3 Proposed Drainage System

The site generally grades from northwest to southeast and west to east. The proposed drainage design will be divided into two sub-catchments (Northern & Southern sub catchments) and two discharge points to the existing stormwater easement along the eastern boundary.

The proposed stormwater management system for the development will include:

- A pit and pipe network to collect minor storm runoff from areas
- Overland flow paths to carry major storms through the site
- Above ground On-site detention (OSD) tank with orifice and weir control for northern catchment

- Underground On-site detention (OSD) tank with orifice and weir control for southern catchment
- Water quality devices to provide treatment to stormwater runoff from the site and achieve council treatment efficiency targets
- 2x 75 KL rainwater tank and stormwater treatment system
- Overflow path to carry flow if there is any blockage within the OSD.

The stormwater pipes are designed for flows up to the 5% AEP event and site grading is designed to accommodate the overland flow of stormwater in 1% AEP.

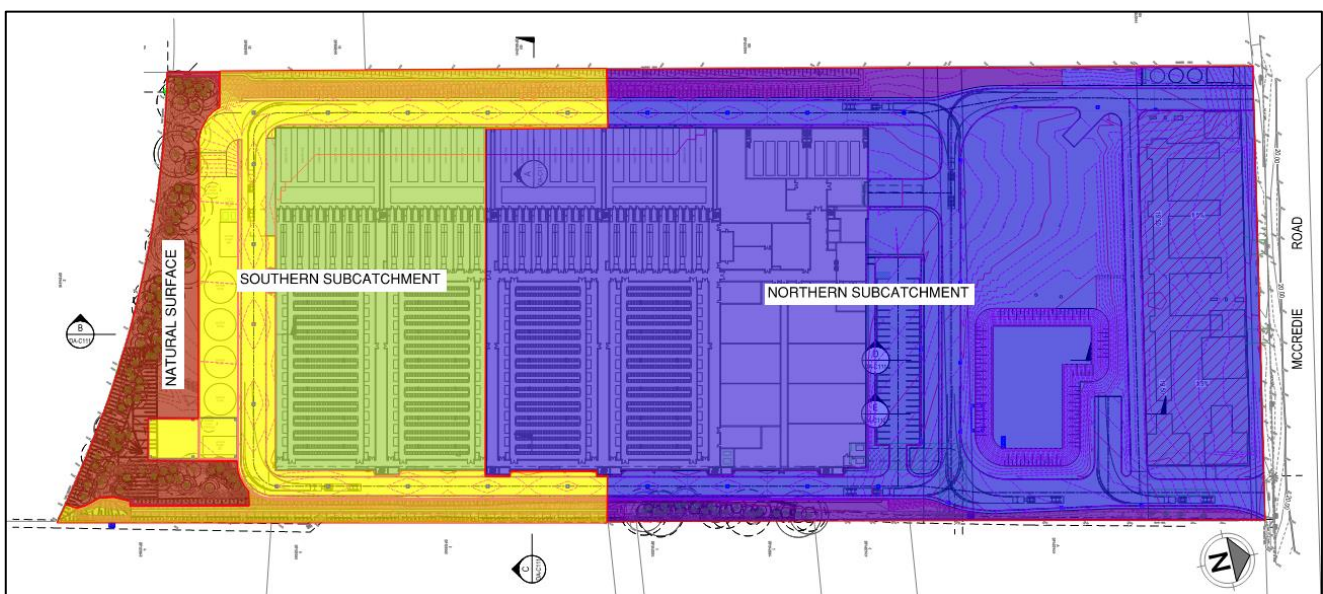

Figure 3 stormwater sub catchment plan

The site is divided into northern and southern sub-catchments. The northern catchment, including the surface area on the north side of the site and northern roof drainage, will drain into the above-ground OSD. The controlled discharge will be connected to the existing stormwater easement pipeline along the eastern boundary. Surface overland flow will drain toward the sag point at the middle of the eastern boundary and spill into the existing natural surface area, flowing southeast of the site towards Prospect Creek.

The southern catchment, including the surface and southern roof area, will drain into the underground OSD tank located at the southeastern corner of the site. The controlled discharge will flow into the existing Council pipeline adjacent to the southeastern boundary. Overland flow will drain southeast towards Prospect Creek.

The southern natural surface of the site is significantly lower than the development area. As directing surface runoff toward the OSD is not feasible due to the presence of existing trees, this area is excluded from the OSD drainage catchment.

Refer to the Appendix A for further details.

A roof drainage system will be used to drain the building roof. The box gutter system will be sized for a 1:100yr ARI storm event. In the southern area, southern roof drainage is connected to an underground rainwater tank. This tank will overflow into the underground pipeline routes and drain into the WSUD chamber for water treatment and Civil stormwater system respectively.

Also, in the northern area, the northern roof drainage is connected to an underground rainwater tank. This tank will overflow into the underground pipeline routes and drain into the WSUD chamber for water treatment and Civil stormwater system respectively.

2.4 On-Site Stormwater Detention (OSD)

OSD main objective is attenuate peak flows from the development due to increasing impervious area to make sure there will be no increase on peak flow on the downstream end.

The OSD is Designed based on standards of Upper Parramatta River catchment Trust Handbook (UPRCT) 4th edition December 2005. Therefore, two OSD systems are proposed to capture the site northern and southern sub-catchments and discharge into the council easement along the eastern boundary.

As the external work will be completed during Stage 1 of the construction, both OSD systems will be constructed in Stage 1.

The Stage 2 stormwater connection to the southern OSD system can be sealed during Stage 1 and connected upon the completion of Stage 2.

Refer to Appendix A for further information regarding OSD sizing and details.



3. Stormwater Quality Control

3.1 Objective and Control

According to Cumberland City Council DCP Part G, the stormwater quality requirements are as follows:

- 85% reduction in the mean annual load of Total Suspended Solids (TSS)
- 60% reduction in the mean annual load of Total Phosphorus (TP)
- 60% reduction in the mean annual load of Total Nitrogen (TN)
- 90% reduction in the mean annual load of gross pollutants
- 90% reduction in the mean annual load of hydrocarbons

3.2 Proposed Stormwater Quality Treatment Measures

Stormwater generated by building roof, paved surface area and landscape area will be conveyed via road pits and pipes drainage around the building to stormwater treatments devices. The treatment train proposed for the development are summarised below:

Refer to Appendix A for further details regarding water quality and rainwater tank locations for each sub catchment.

- **ATLAN Vortceptor**
The Atlan Vortceptor Gross Pollutant Trap (GPT) is a non-blocking hydrodynamic separator that has a unique screen and treatment action producing low vortex conditions resulting in excellent pollution removal performance and resulting high water quality outcomes. It separates and captures gross pollutants, sediments, silt, total suspended solids, some nutrients and oil and grease. 4x Atlan Vortceptor GPTs are to be provided treat incoming stormwater to the OSD systems.
- **ATLAN Stormsack**
Atlan Stormsack is one of the stormwater treatment devices designed to capture stormwater pollutants. It is effective in removing gross pollutants and suspended solids. 6x Atlan Stormsack are to be provided treat incoming stormwater to the OSD systems.
- **ATLAN Filters**
Atlan Filters are to be provided as the tertiary stormwater treatment for the subject site. 15x Atlan Filters are to be placed inside the water quality tank for northern catchment and 15x Atlan Filters are to be placed inside the proposed OSD tank for southern catchment. Atlan Filters are effective in reducing a high level of stormwater pollutants including total suspended solids, phosphorus, and nitrogen. There will be a total of 30x ATLAN Filter cartridges within the water quality treatment tanks associated with two OSD treatment systems as detailed in the engineering drawings. Refer to Appendix A for further details



- Rainwater Tanks**
 2x 75 KL rainwater tank will be placed at proposed location and will be reused for the building cooling tower system, flushing and irrigation. Refer to Appendix A for further details
- Erosion and Sediment Control**
 During construction, water quality control is achieved by deposition and trapping of silts and clays which often have nutrients such as phosphorus and nitrogen attached to their surfaces. Silt fences will be erected prior to construction to control sediment runoff. This will reduce and isolate sediments and particulate matter. An Erosion and Sediment Control Plan has been provided in accordance with Landcoms “Managing Urban Stormwater – Soils and Construction (2004)”. This will ensure that a significant portion of sediments and attached nutrients can be contained on site during construction. Erosion and Sediment control plan is contained within the Civil Engineering Plans shown in Appendix A.

3.3 MUSIC Results

The MUSIC model layout and results is shown on Figure 4 & Table 2 below. The values summarise the stormwater pollutant reduction for the entire treatment train. The MUSIC analysis results indicate that the proposed stormwater treatment devices are able to satisfy the Cumberland City Council stormwater quality reduction objectives for TSS, TP, TN, gross pollutants and hydrocarbons.

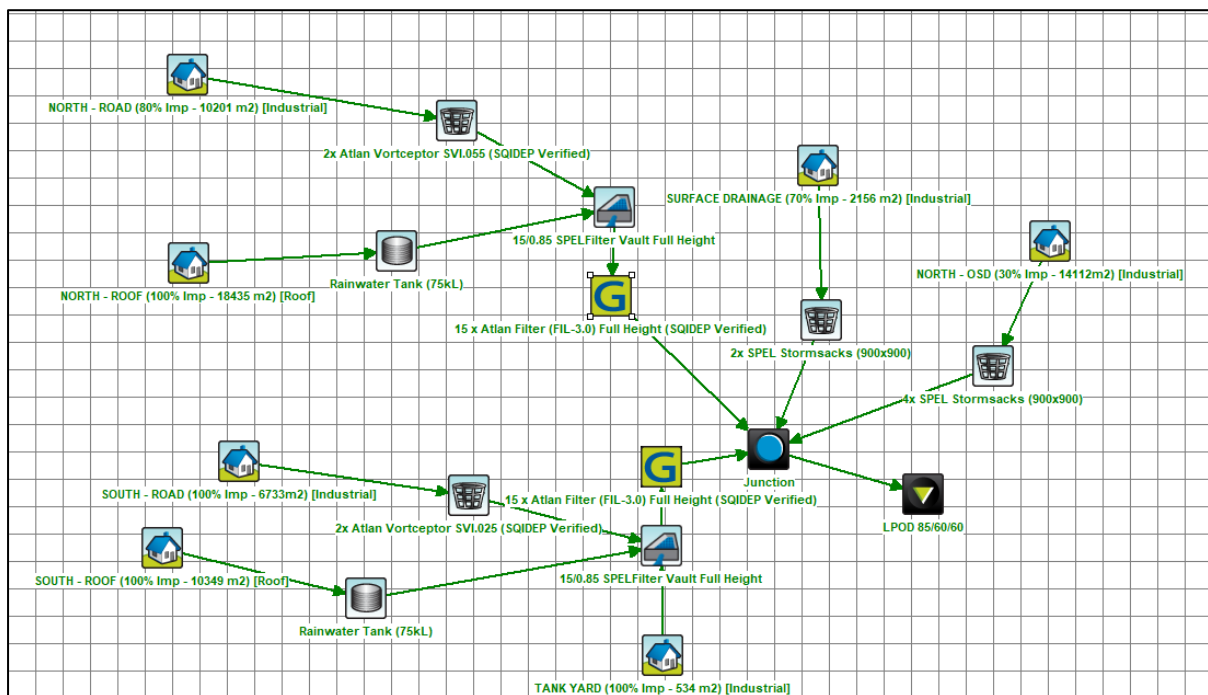

Figure 4 MUSIC model

Table 2: MUSIC Results

	Sources	Residual Load	%Reduction	DCP %Reduction Targets
Flow (ML/year)	44.9	40.4	9.9	-
Total Suspended Soils (kg/year)	4350	597	86.3	85
Total Phosphorus (kg/year)	9.73	20.54	73.9	60
Total Nitrogen (kg/year)	97.4	33.8	65.3	60
Gross Pollutant (kg/year)	1230	1.07	99.9	90

Hydrocarbons targets are address by installing Atlan Vortceptor GPT, according to Fairfield Council requirements. Refer to Appendix B for further details and manufacturers documents.

3.4 Stormwater Drainage Maintenance

Monitoring and maintenance are required to ensure the stormwater system works as intended for the life of the development. Any unusual event regarding stormwater system should be investigated and mitigated as soon as possible such as localised flooding. However, stormwater treatment devices are designed to allow for overflow if it get blocked. So, even when the devices stop working, it can go unnoticed. Therefore, regular inspections are required for each treatment device. These are to be scheduled to ensure devices are cleaned as necessary and any defects discovered rectified. Inspections are also to be performed after any large rainfall event.

Refer to Appendix B for complete maintenance schedule for stormwater system/devices proposed for the development.

4. Water

According to the hydraulic information provided by the hydraulic consultant for this development, the water supply and demand details are outlined in the sections below.

4.1 Recycled Water

Cooling towers will be provided with a concurrently maintainable critical water supply and 24 hours water storage in the event of water mains failure. The 24 hours water storage requirement being a total of 4,713 kL which broken up into 9x 563kL water storage tanks located on the southern side of the site.

According to the hydraulic consultants, water supply and demand for stage 1 and 2 is listed below, as shown in figures below. The values below assume that the mechanical evaporative cooling profile for an operational facility utilises heat rejection continuously year-round with the annual variance of 1.05% across seasons and would represent a flat line across a usage profile. Refer to ARUP cooling towers calculation sheet in hydraulic doementation for further details.

Stage 1 – 50MVA		
Description	Quantity	UOM
Evaporative Cooling cycles of concentration	6	16% of inflow to waste
Average Potable Water Supply	14	kL/day (@ 80% peak)
Peak Potable Water Supply	18	kL/day
Average Recycled Water Supply	1,670	kL/day (@ 80% peak)
Peak Recycled Water Supply	2,087	kL/day
Average Sewer Discharge	287.6	ML/day (@ 80% peak)
Peak Sewer Discharge	360	kL/day
Fire Water Supply	76.5	Aggregate L/s fire scenario only
Hydrants	30	L/s fire scenario only
Sprinklers	46.5	L/s fire scenario only
Landscaping Water Supply	14	kL/day (Add to RW peak)

Figure 5: Stage 1 Water Supply, ARUP hydraulic calculations

Stage 2 – 100MVA		
Description	Quantity	UOM
Evaporative Cooling cycles of concentration	6	16% of inflow to waste
Average Potable Water Supply	0	kL/day (@ 80% peak) As per stage 1
Peak Potable Water Supply	0	kL/day As per stage 1
Average Recycled Water Supply	2087.2	ML/day (@ 80% peak)
Peak Recycled Water Supply	2,609	kL/day
Average Sewer Discharge	347.52	ML/day (@ 80% peak)
Peak Sewer Discharge	434.4	kL/day
Fire Water Supply	0	As per stage 1
Hydrants	0	As per stage 1
Sprinklers	0	As per stage 1
Landscaping Water Supply	16	kL/day (Add to RW peak)

Figure 6: Stage 2 Water Supply, ARUP hydraulic calculations

4.2 Water Connection Strategy

The potable water supply of the development will connect into an existing 450mm potable water supply on the northeast corner of the site with a potable water supply of 5.1 ML/year.

The recycled water connection of the development will connect into an existing 150mm NPCW Aquanet recycled water main on southwest corner of the site with 4.69 ML peak daily supply. The conceptual water connection strategy is shown on Figure 7 and Figure 8 below.

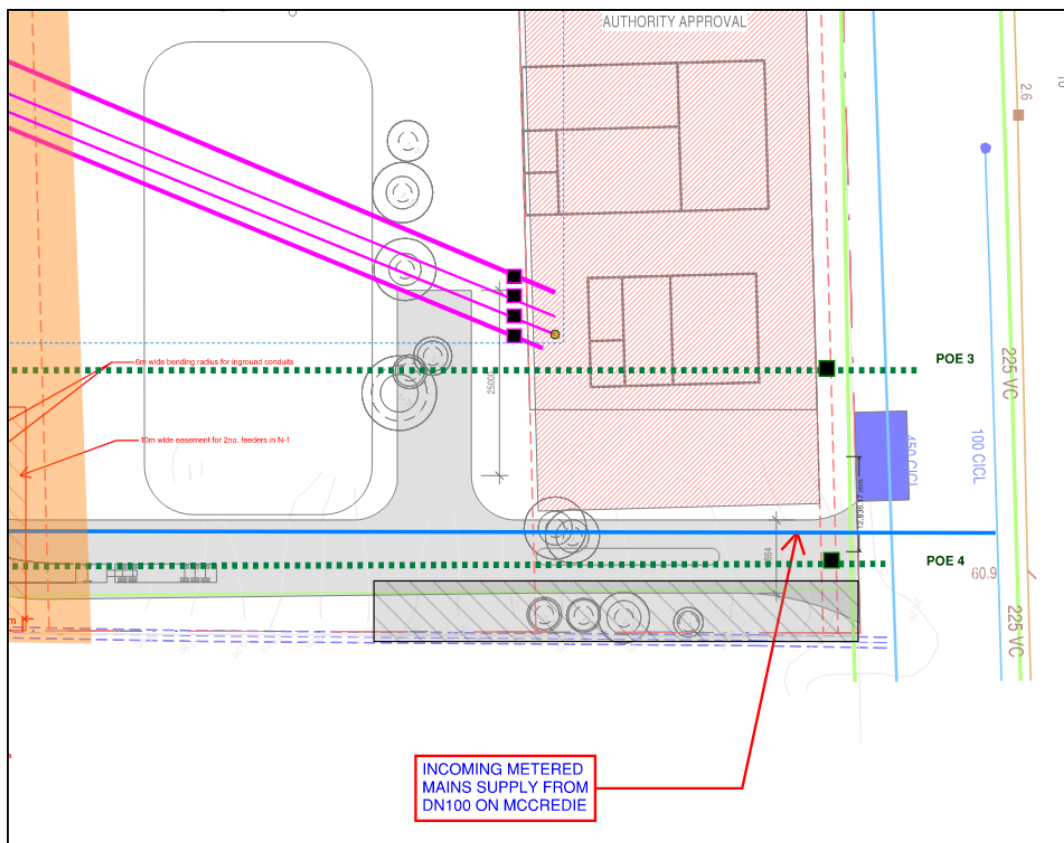

Figure 7 Conceptual potable water connection strategy on northeast corner

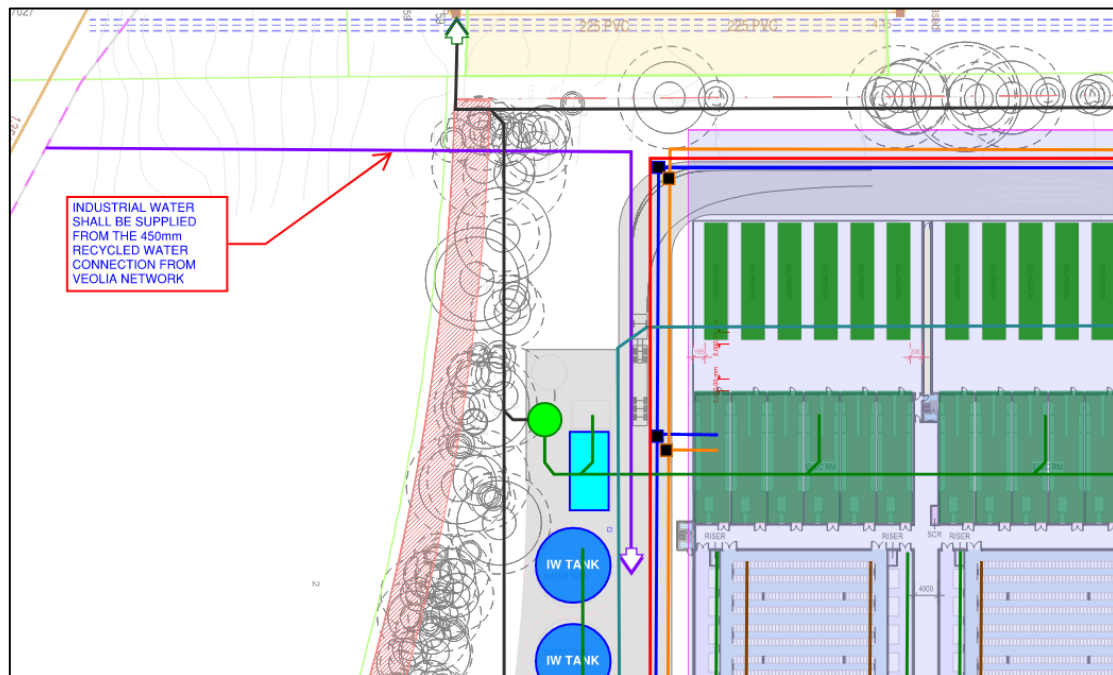

Figure 8 Conceptual recycled water connection strategy on southwest corner

5. Sewer

According to the hydraulic information provided by the hydraulic consultant for this development, the sewer hydraulic details are outlined in the sections below.

5.1 Fire Water

In the unlikely event of a fire where the sprinklers are discharged, the fire water from battery room will be contained in the fire water containment tank. Refer to hydraulic consultants reports for further information.

The inground fire water containment tank will have a capacity of 30 KL. The containment tank will have an overflow into OSD tank. OSD tank will have a site isolation valve fitted for site isolation in fire event.

5.2 Sewer Connection Strategy

Existing 225mm sewer main is located along on the southwestern border of the property. There is an existing sewer line within neighbouring property. Due to lengths of sewer runs prior to new sewer junction works in the south/western corner, 2x sewer pump stations at the southern end of site are proposed and will discharge via pumped rising mains. Location of the sewer pump station is to be confirmed by hydraulic consultants.

The conceptual sewer servicing strategy is shown in Figure 9 and Figure 10 below.

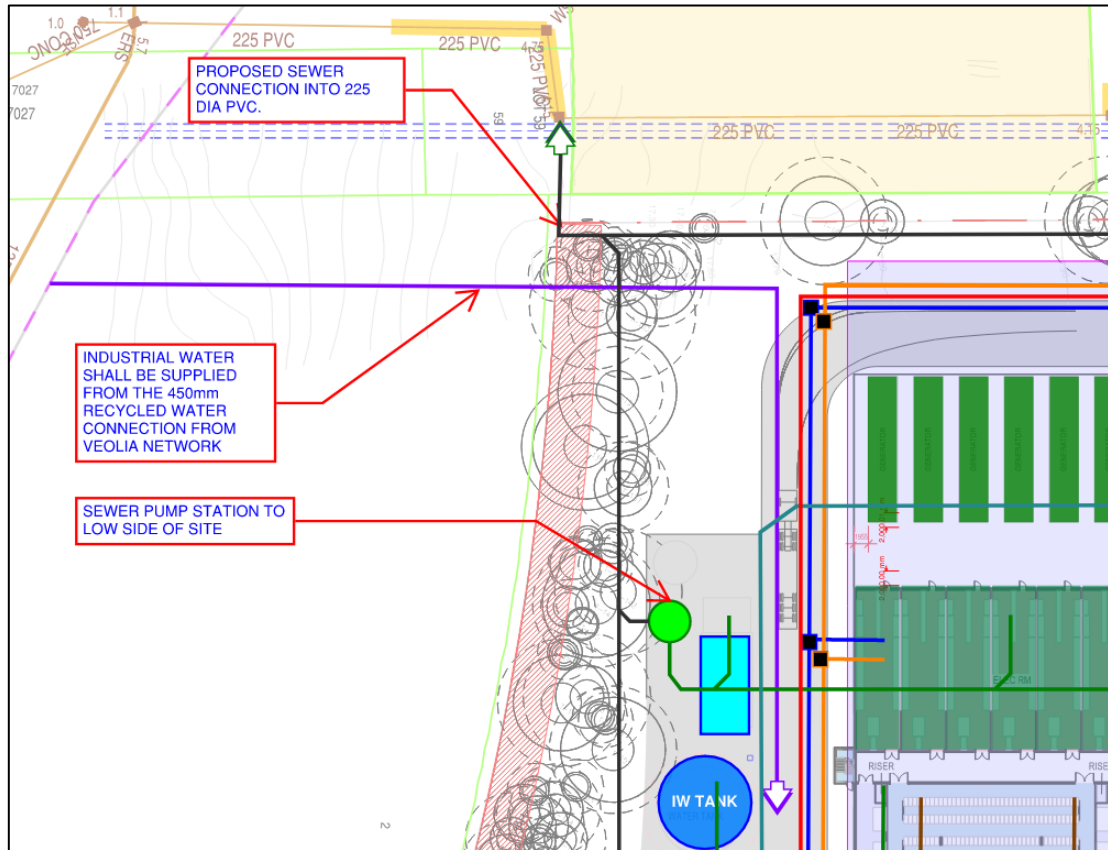

Figure 9 Conceptual sewer connection strategy and 1x sewer pump location

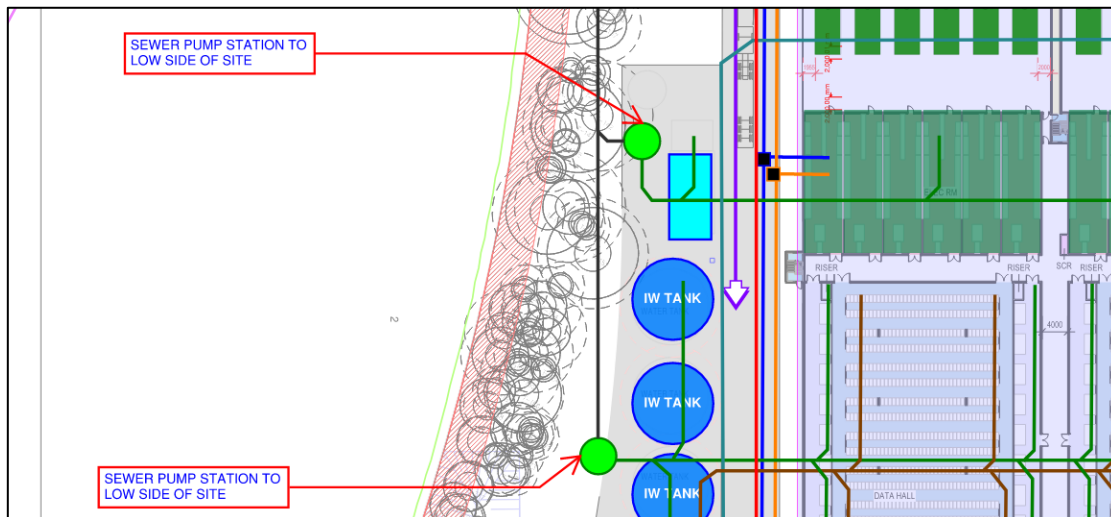

Figure 10 1x sewer pump location and fire water containment tank

6. Water Balance

6.1 Water Supply

Potable water

The Potable water will be used to supply staff amenities and general site demands. will be used to supply general site demands. In final configuration, the estimated average annual potable water supply is 5.1 ML/year, equating to a peak daily water supply of 18 kL/day.

Recycled Water

The recycled water is available, to be used to supply some of the non-potable uses such as cooling towers. The estimated average annual recycled water supply is 1,371 ML/year, equating to a peak daily water supply of 4,696 kL/day.

Rainwater tanks

Rainwater from building roof to be collected, stored, and reused. 2 x 75 KL inground water tanks are proposed for the development, as listed below.

- 1 x tank to supply mechanical cooling only when available - RWT meets 0.2% NPCW demand
- 1 x tank to supply toilet flushing / irrigation supplemented by recycled water - RWT meets 20% NPCW flushing (365 kL/year) / irrigation demand (10.9 ML/year)

A roof drainage system with a catchment area of approximately 23,000 m² can supply an average of 19.93 ML of rainwater per year, based on BOM climate data.

6.2 Water Demand

Potable Water

The potable water demand for staff facilities such as bathrooms, kitchens and cleaning are 1.2ML/yr.

Process Water

The operations consist of an evaporative cooling system with a variable process demand. The daily water demand will vary depending on temperature. In final configuration, the estimated average annual recycle water demand is 1,376 ML/year, equating to a peak daily water demand of 4,713 kL/day. This water will be supplied by harvested rainwater, Aquanet recycled water or potable water when harvested rainwater and recycled water is unavailable.



6.3 Water Discharge

Sewer

Minimal water used on the site will be discharged to the sewer. In final configuration, the estimated average annual sewer discharge is 231 ML/year, equating to a peak daily sewer discharge of 794 kL/day.

Site stormwater runoff

The site stormwater runoff will be conveyed to the outlet connection points noted previously. This will include overflow from the rainwater tanks when they are full. Based on Sydney annual rainfall of 877mm per year, the estimated annual site stormwater discharge from rainfall on site is 63ML/yr.

6.4 Water Balance Summary

A summary of the results of the site water balance in the final configuration is included in Table 3 below for stage 1 and 2.

Table 3 Water balance summary

Water Source	Annual Average Total (ML)	
	Inflow	Outflow
Rainfall	63	
Rainwater Reuse		19.9
Stormwater Discharge		41.1
Potable Water Supply	5.1	
Non-Potable Water Supply	1371	
Water Usage for Irrigation		10.9
Water Usage for Toilets		0.37
Potable Water Usage		1.2
Non-Potable Water Usage		1,376
Sewer Discharge		231
Total	1,439.1	1,680.47

To validate these results, the estimated annual reuse was verified using the MUSIC water quality model. Average estimates from each method are within 20% of each other, which is considered acceptable.

7. Conclusion

The proposed development will involve civil engineering activities such as earthworks, pavement, and drainage work.

The results from the investigations and assessment for this project summarised in this report. The results indicate the development with the proposed stormwater and utilities strategy and management can meet council's stormwater objectives for the site and satisfy SEARs conditions.



APPENDIX A- CIVIL PLANS



AUCKLAND
L8, 139 Quay St
Auckland NZ

BRISBANE
L3, 51 Alfred St
Fortitude Valley

CANBERRA
L9, 2 Phillip Law St
Canberra

MELBOURNE
L6, 379 Collins St
Melbourne

NEWCASTLE
L1, 17 Bolton St
Newcastle

SYDNEY
L6, 39 Chandos St
St Leonards





PLAN
SCALE 1:750

REVISIONS:	
No.	REVISION DESCRIPTION
A	SSDA

SCALE BAR
0 10 20 30 40 50m 75m
SCALE 1:750

van der Meer Consulting
van der Meer (NSW) Pty Ltd
LEVEL 6, 39 CHANDOS STREET
ST LEONARDS NSW 2065
Telephone 61-2-9436 0433 Fax 61-2-9436 1370

van der Meer
www.vandermeer.com.au
van der Meer (NSW) Pty Ltd
A.B.N. 56 158 266 301

WHERE THE DRAWING HAS BEEN ALTERED, AMENDED OR CHANGED EITHER MANUALLY OR ELECTRONICALLY BY ANY THIRD PARTY, THIS IS AN UNCONTROLLED DOCUMENT ISSUED FOR INFORMATION PURPOSES ONLY. UNLESS SIGNED, FIGURES DIMENSIONING TAKE PRECEDENCE OVER SCALED. DO NOT SCALE REDUCED SIZE DRAWINGS. VERIFY DIMENSIONING PRIOR TO COMMENCING ANY ON-SITE OR OFF-SITE WORKS OR FABRICATION. IF IN DOUBT - ASK.

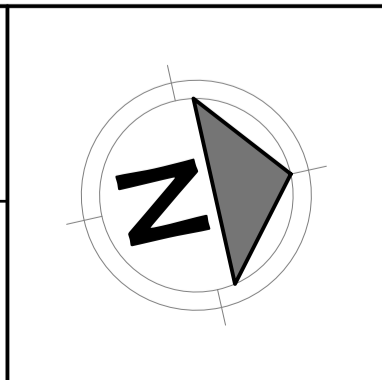

van der Meer Consulting
van der Meer (NSW) Pty Ltd
LEVEL 6, 39 CHANDOS STREET
ST LEONARDS NSW 2065
Telephone 61-2-9436 0433 Fax 61-2-9436 1370

van der Meer
www.vandermeer.com.au
van der Meer (NSW) Pty Ltd
A.B.N. 56 158 266 301

CLIENT
GOODMAN PROPERTY SERVICES (AUST) PTY LTD

PROJECT TITLE
PROJECT PLUTO
132 MCCREDIE ROAD
GUILDFORD WEST NSW 2161

ARCHITECT
GREENBOX ARCHITECTURE
LEVEL 22, 68 PITT STREET, SYDNEY NSW 2000

DRAWING TITLE
SITE PLAN - STAGE 1

DRAWING STATUS
APPROVAL ISSUE
NOT TO BE USED FOR CONSTRUCTION

PROJECT LEADER AW	DESIGNER HB/VB	SIGNATURE
DRAFTSPERSON HB/VB	SCALE 1:750	DATE DRAWN
JOB No. SY242-012	DRAWING No. SSDA-C101	SHEET SIZE A1
		REVISION A

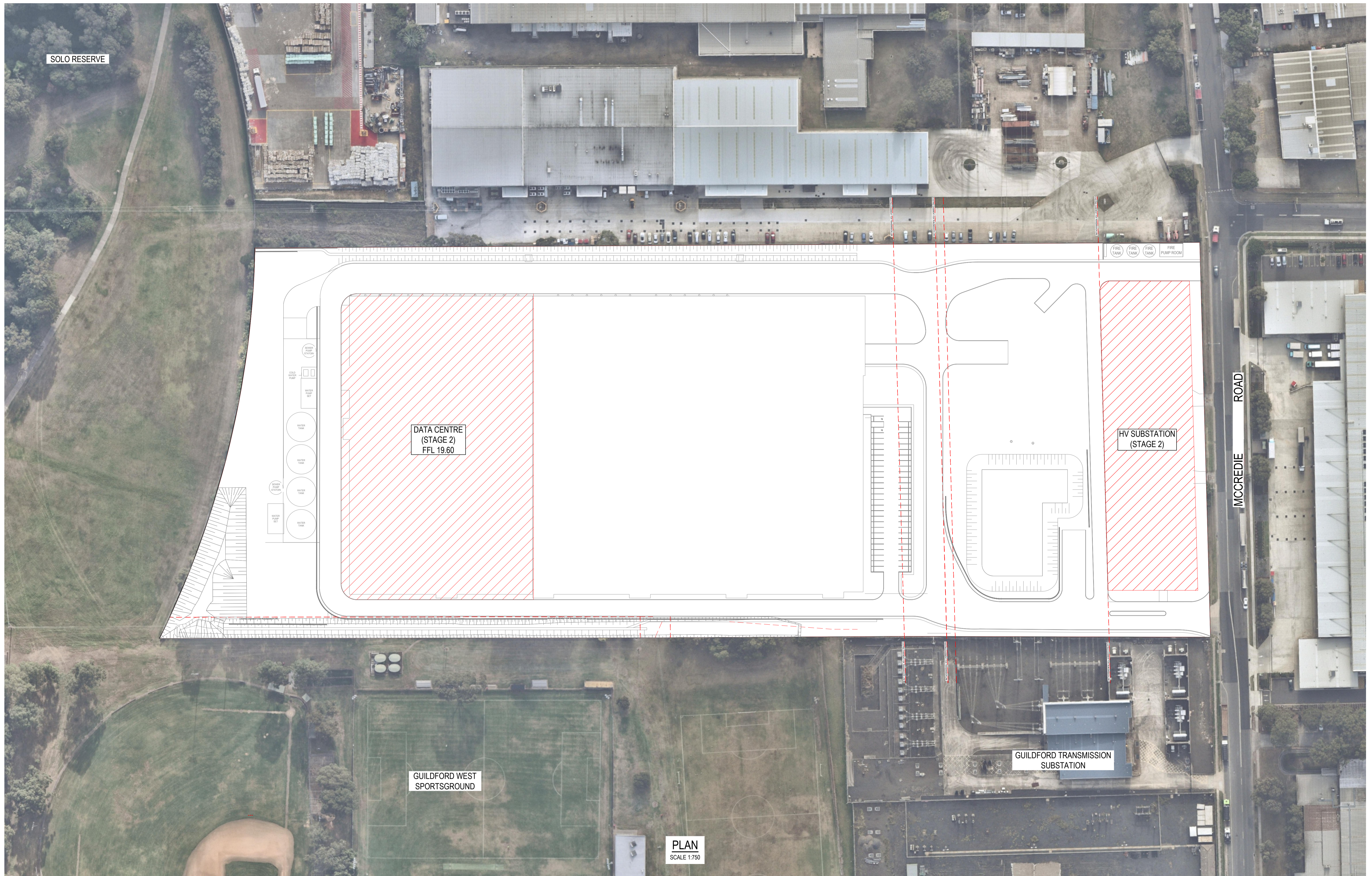

PLAN
SCALE 1:750

REVISIONS:	
No.	REVISION DESCRIPTION
A	SSDA

SCALE BAR
0 10 20 30 40 50m 75m
SCALE 1:750

COPYRIGHT © THE DRAWING IS COPYRIGHT AND THE PROPERTY OF VANDER MEER (NSW) PTY LTD. IT MUST NOT BE REPRODUCED, COPIED OR USED WITHOUT THE AUTHORITY OF VANDER MEER (NSW) PTY LTD.
THIS DRAWING AND ITS CONTENTS ARE ELECTRONICALLY GENERATED, ARE CONFIDENTIAL AND MAY ONLY BE USED FOR THE PURPOSE FOR WHICH THEY WERE INTENDED. VANDER MEER (NSW) PTY LTD WILL NOT ACCEPT RESPONSIBILITY FOR ANY CONSEQUENCES ARISING FROM THE USE OF THIS DRAWING FOR OTHER THAN ITS INTENDED PURPOSE OR WHERE THE DRAWING HAS BEEN ALTERED, AMENDED OR CHANGED EITHER MANUALLY OR ELECTRONICALLY BY ANY THIRD PARTY.
THIS IS AN UNCONTROLLED DOCUMENT ISSUED FOR INFORMATION PURPOSES ONLY. UNLESS SIGNED, FIGURED DIMENSIONING TAKE PRECEDENCE OVER SCALED, DO NOT SCALE REDUCED SIZE DRAWINGS. VERIFY DIMENSIONS PRIOR TO COMMENCING ANY ON-SITE OR OFF-SITE WORKS OR FABRICATION. IF IN DOUBT - ASK.

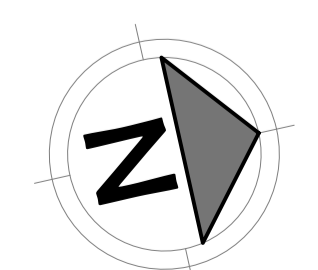

van der Meer Consulting
van der meer

LEVEL 6, 39 CHANDOS STREET
ST LEONARDS NSW 2065
Telephone 61-2-9436 0433 Fax 61-2-9436 1370

www.vandermeer.com.au
van der Meer (NSW) Pty Ltd
A.B.N. 56 158 266 301

CLIENT
GOODMAN PROPERTY SERVICES (AUST) PTY LTD

ARCHITECT
GREENBOX ARCHITECTURE
LEVEL 22, 68 PITT STREET, SYDNEY NSW 2000







PROJECT TITLE
PROJECT PLUTO
132 MCCREDIE ROAD
GUILDFORD WEST NSW 2161

DRAWING TITLE
SITE PLAN - STAGE 2

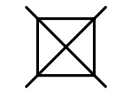
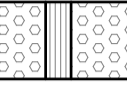
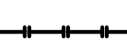
DRAWING STATUS
APPROVAL ISSUE
NOT TO BE USED FOR CONSTRUCTION

PROJECT LEADER AW	DESIGNER HB/VB	SIGNATURE	
DRAFTSPERSON HB/VB	SCALE 1:750	DATE DRAWN	SHEET SIZE A1
JOB No. SY242-012		DRAWING No. SSDA-C102	REVISION A

LEGEND

-  STORMWATER SEDIMENT TRAPS AT ALL PROPOSED PIT INLETS
-  TEMPORARY CONSTRUCTION VEHICLE EXIT
-  SEDIMENT CONTROL FENCE
-  STOCKPILE AREA
-  SANDBAG KERB INLET SEDIMENT TRAP
-  TEMPORARY SEDIMENT BASIN
-  PROPOSED TREE REFER TO LANDSCAPE ARCHITECT'S PLAN
-  EXISTING TREE TO BE RETAINED REFER TO LANDSCAPE ARCHITECT'S PLAN
-  EXISTING TREE TO BE DEMOLISHED REFER TO LANDSCAPE ARCHITECT'S PLAN



PLAN
SCALE 1:750

REVISIONS:	
No.	REVISION DESCRIPTION
A	SSDA

SCALE BAR
0 10 20 30 40 50m 75m
SCALE 1:750

COPYRIGHT © THE DRAWING IS THE PROPERTY OF VANDER MEER CONSULTING PTY LTD. IT MUST NOT BE REPRODUCED, COPIED OR USED WITHOUT THE AUTHORITY OF VANDER MEER CONSULTING PTY LTD. WHERE THE DRAWING HAS BEEN ALTERED, AMENDED OR CHANGED EITHER MANUALLY OR ELECTRONICALLY BY ANY THIRD PARTY, THIS IS AN UNCONTROLLED DOCUMENT ISSUED FOR INFORMATION PURPOSES ONLY UNLESS SIGNED. FIGURES DIMENSIONING TAKE PRECEDENCE OVER SCALES. DO NOT SCALE REDUCED SIZE DRAWINGS. VERIFY DIMENSIONS PRIOR TO COMMENCING ANY ON-SITE OR OFF-SITE WORKS OR FABRICATION. IF IN DOUBT - ASK.

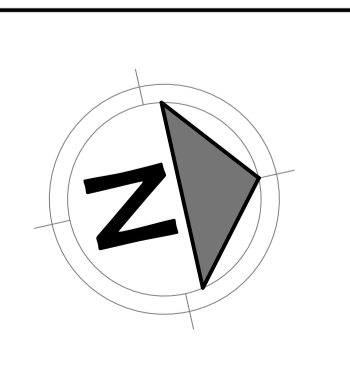

van der Meer Consulting
van der meer

LEVEL 6, 39 CHANDOS STREET
ST LEONARDS NSW 2065
Telephone 61-2-9436 0433 Fax 61-2-9436 1370

www.vandermeer.com.au
van der Meer (NSW) Pty Ltd
A.B.N. 56 158 266 301

CLIENT
GOODMAN PROPERTY SERVICES (AUST) PTY LTD

ARCHITECT
GREENBOX ARCHITECTURE
LEVEL 22, 68 PITT STREET, SYDNEY NSW 2000

PROJECT TITLE
PROJECT PLUTO
132 MCCREDIE ROAD
GUILDFORD WEST NSW 2161

DRAWING TITLE
EROSION AND SEDIMENT CONTROL PLAN

DRAWING STATUS			
APPROVAL ISSUE			
NOT TO BE USED FOR CONSTRUCTION			
PROJECT LEADER	DESIGNER	SIGNATURE	
AW	HB/VB		
DRAFTSPERSON	SCALE	DATE DRAWN	SHEET SIZE
HB/VB	1:750		A1
JOB No.	DRAWING No.	REVISION	
SY242-012	SSDA-C121	A	

EROSION AND SEDIMENT NOTES

B1. THIS PLAN IS TO BE READ IN CONJUNCTION WITH EROSION AND SEDIMENT CONTROL DETAILS AS SHOWN

B2. THE CONTRACTOR SHALL IMPLEMENT ALL SOIL EROSION AND SEDIMENT CONTROL MEASURES AS NECESSARY AND TO THE SATISFACTION OF COUNCIL PRIOR TO THE COMMENCEMENT OF AND DURING CONSTRUCTION. NO DISTURBANCE TO THE SITE SHALL BE PERMITTED OTHER THAN IN THE IMMEDIATE AREA OF THE WORKS AND NO MATERIAL SHALL BE REMOVED FROM THE SITE WITHOUT COUNCIL'S APPROVAL. ALL EROSION AND SEDIMENT CONTROL DEVICES TO BE INSTALLED AND MAINTAINED IN ACCORDANCE WITH STANDARDS OUTLINED IN NSW DEPARTMENT OF HOUSING'S "MANAGING URBAN STORMWATER - SOILS AND CONSTRUCTIONS".

B3. TOPSOIL SHALL BE STRIPPED AND STOCKPILED OUTSIDE HAZARD AREAS SUCH AS DRAINAGE LINES. THIS TOPSOIL IS TO BE RESPREAD LATER ON AREAS TO BE REVEGETATED AND STABILISED ONLY, (I.E. ALL FOOTPATHS, BATTERS, SITE REGARDING AREAS, BASINS AND CATCHDRAINS). TOPSOIL SHALL NOT BE RESPREAD ON ANY OTHER AREAS UNLESS SPECIFICALLY INSTRUCTED BY THE SUPERINTENDENT. IF THEY ARE TO REMAIN FOR LONGER THAN ONE MONTH STOCKPILES SHALL BE PROTECTED FROM EROSION BY COVERING THEM WITH A MULCH AND HYDROSEEDING AND, IF NECESSARY, BY LOCATING BANKS OR DRAINS DOWNSTREAM OF A STOCKPILE TO RETARD SILT LADEN RUNOFF.

B4. THE CONTRACTOR SHALL REGULARLY MAINTAIN ALL EROSION AND SEDIMENT CONTROL DEVICES AND REMOVE ACCUMULATED SILT FROM DEVICES SUCH THAT NO MORE THAN 60% OF THEIR CAPACITY IS LOST. ALL THE SILT IS TO BE PLACED OUTSIDE THE LIMIT OF WORKS. THE PERIOD FOR MAINTAINING THESE DEVICES SHALL BE AT LEAST UNTIL ALL DISTURBED AREAS ARE REVEGETATED OR AS DIRECTED BY THE SUPERINTENDENT OR COUNCIL.

B5. VEHICULAR TRAFFIC SHALL BE CONTROLLED DURING CONSTRUCTION CONFINING ACCESS WHERE POSSIBLE TO NOMINATED STABILISED ACCESS POINTS.

B6. THE CONTRACTOR SHALL IMPLEMENT DUST CONTROL BY REGULAR WETTING DOWN (BUT NOT SATURATING) DISTURBED AREA.

B7. PROVIDE AND MAINTAIN SILT TRAPS AROUND ALL SURFACE INLET PITS UNTIL CATCHMENTS ARE REVEGETATED OR PAVED.

B8. REVEGETATE ALL TRENCHES IMMEDIATELY UPON COMPLETION OF BACKFILLING.

B9. ALL DRAINAGE PIPE INLETS TO BE CAPPED UNTIL:
A) DOWNPIPES CONNECTED
B) PITS CONSTRUCTED AND PROTECTED WITH SILT BARRIER

B10. SILT FENCE MAINTENANCE INSPECTION TO BE CARRIED OUT EVERY 3 MONTHS AND AFTER EACH RAINFALL EVENT.

B11. EROSION & SEDIMENT CONTROL SIGNAGE AVAILABLE FROM COUNCIL MUST BE ATTACHED TO THE MOST PROMINENT AVAILABLE STRUCTURE AND BE VISIBLE AT ALL TIMES WHEN ENTERING THE SITE FOR THE DURATION OF CONSTRUCTION.

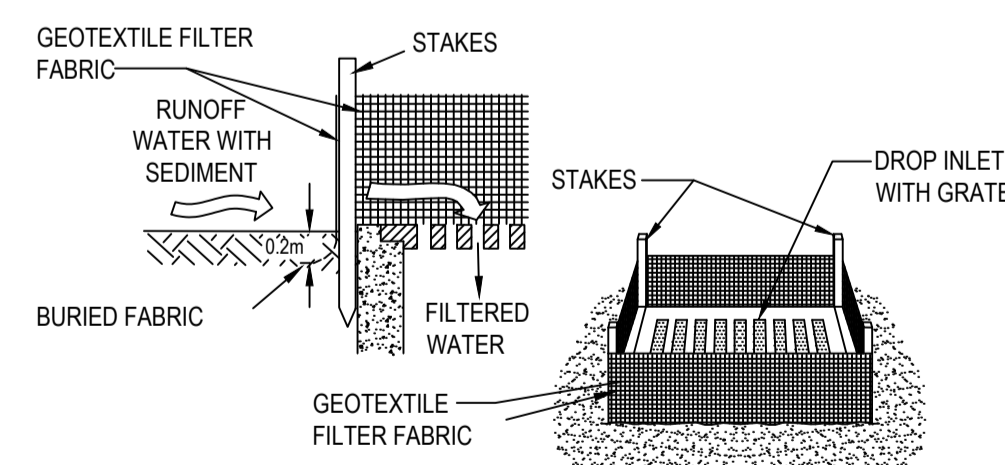

**GEOTEXTILE FILTER FABRIC INLET
SEDIMENT TRAP**
N.T.S.

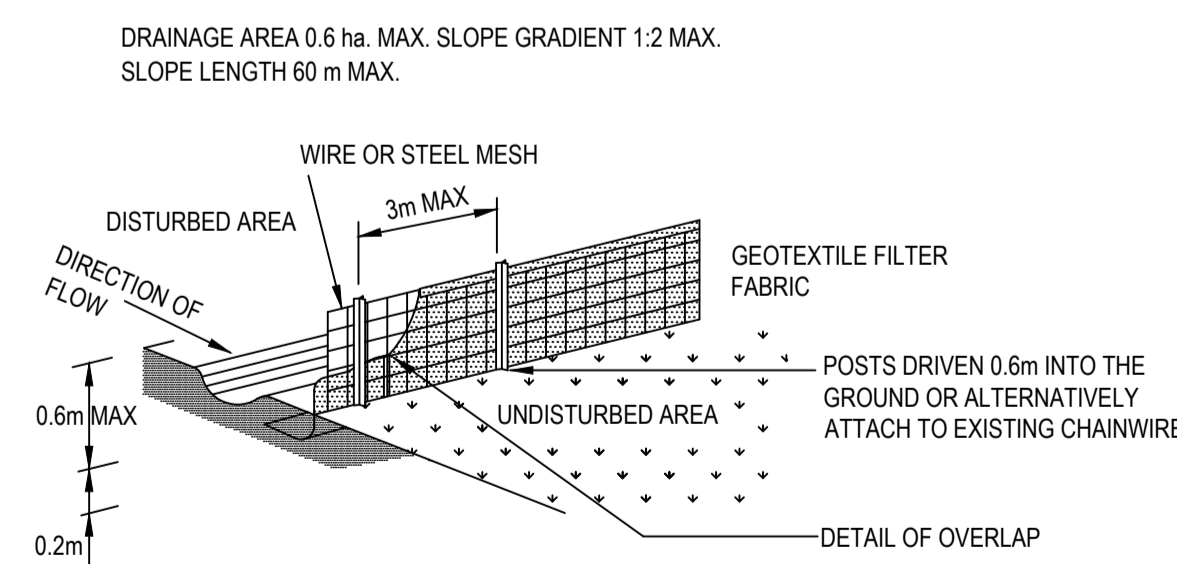

SEDIMENT CONTROL FENCE
N.T.S.

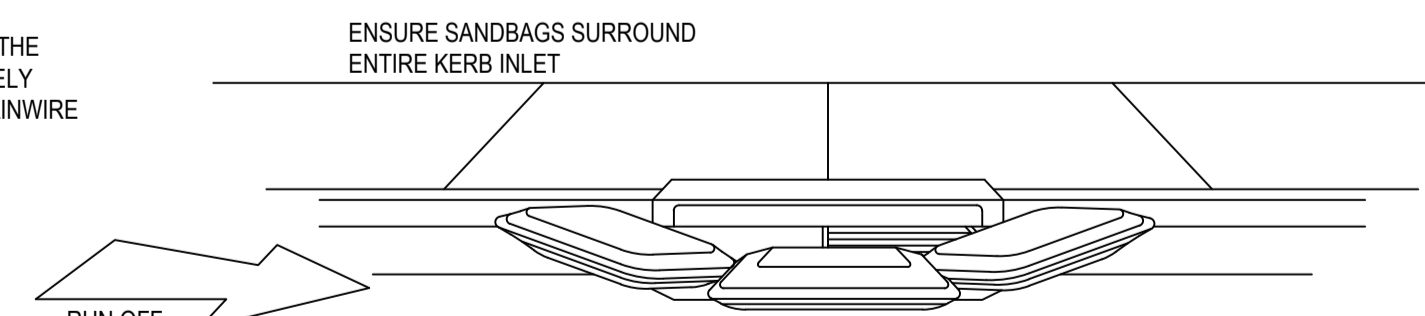

SANDBAG KERB INLET SEDIMENT TRAP
N.T.S.

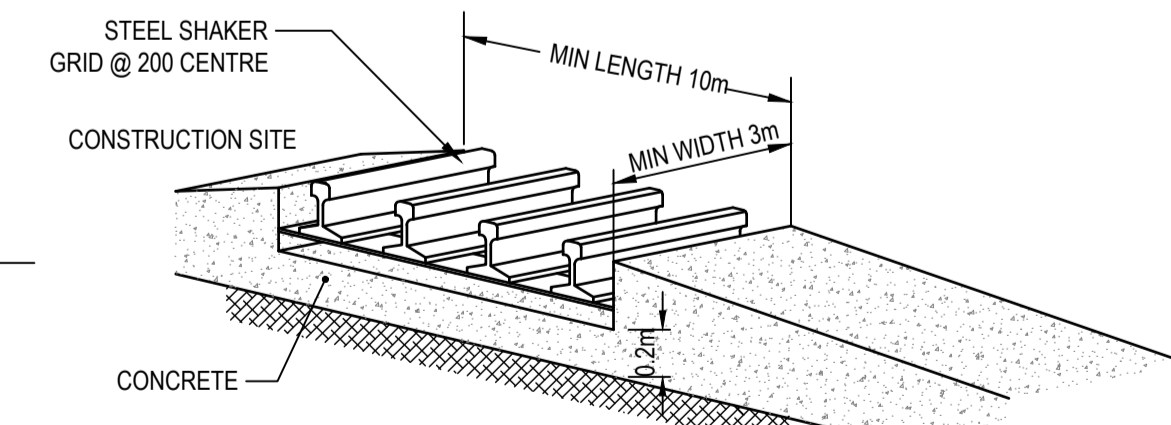

**TEMPORARY CONSTRUCTION
VEHICLE EXIT**
N.T.S.

REVISIONS:		SCALE BAR	
No.	REVISION DESCRIPTION	DRAWN	DATE
A	SSDA	VB	12.03.2025

<small>COPYRIGHT © THIS DRAWING IS COPYRIGHT AND THE PROPERTY OF VAN DER MEER (NSW) PTY LTD. IT MUST NOT BE REPRODUCED, COPIED OR USED WITHOUT THE AUTHORITY OF VAN DER MEER (NSW) PTY LTD. DISCLAIMER: VAN DER MEER (NSW) PTY LTD. WILL NOT ACCEPT RESPONSIBILITY FOR ANY CONSEQUENCES ARISING FROM THE USE OF THIS DRAWING FOR OTHER THAN ITS INTENDED PURPOSE OR WHERE THE DRAWING HAS BEEN ALTERED, AMENDED OR CHANGED EITHER MANUALLY OR ELECTRONICALLY BY ANY THIRD PARTY. NOTE: THIS IS AN UNCONTROLLED DOCUMENT ISSUED FOR INFORMATION PURPOSES ONLY UNLESS SIGNED. FIGURED DIMENSIONS TAKE PRECEDENCE OVER SCALED. DO NOT SCALE REDUCED SIZE DRAWINGS. VERIFY DIMENSIONS PRIOR TO COMMENCING ANY ON-SITE OR OFF-SITE WORKS OR FABRICATION. IF IN DOUBT - ASK.</small>	
--	--

van der Meer Consulting
van der meer
 LEVEL 6, 39 CHANDOS STREET
 ST LEONARDS NSW 2065
 Telephone 61-2-9436 0433 Fax 61-2-9436 1370
 www.vandermeer.com.au
 van der Meer (NSW) Pty Ltd
 A.B.N. 56 158 266 301

CLIENT	GOODMAN PROPERTY SERVICES (AUST) PTY LTD
ARCHITECT	GREENBOX ARCHITECTURE LEVEL 22, 68 PITT STREET, SYDNEY NSW 2000

PROJECT TITLE	PROJECT PLUTO 132 MCCREDIE ROAD GUILDFORD WEST NSW 2161
DRAWING TITLE	EROSION AND SEDIMENT CONTROL DETAILS

DRAWING STATUS			
APPROVAL ISSUE NOT TO BE USED FOR CONSTRUCTION			
PROJECT LEADER	DESIGNER	SIGNATURE	
AW	HB/VB		
DRAFTSPERSON	SCALE	DATE DRAWN	SHEET SIZE
HB/VB	AS SHOWN		A1
JOB No.	DRAWING No.	REVISION	
SY242-012	SSDA-C151	A	

WARNING

BEWARE OF UNDERGROUND SERVICES
 THE LOCATIONS OF UNDERGROUND SERVICES ARE APPROXIMATE ONLY AND THEIR EXACT POSITION SHOULD BE PROVEN ON SITE. NO GUARANTEE IS GIVEN THAT ALL EXISTING SERVICES ARE SHOWN.

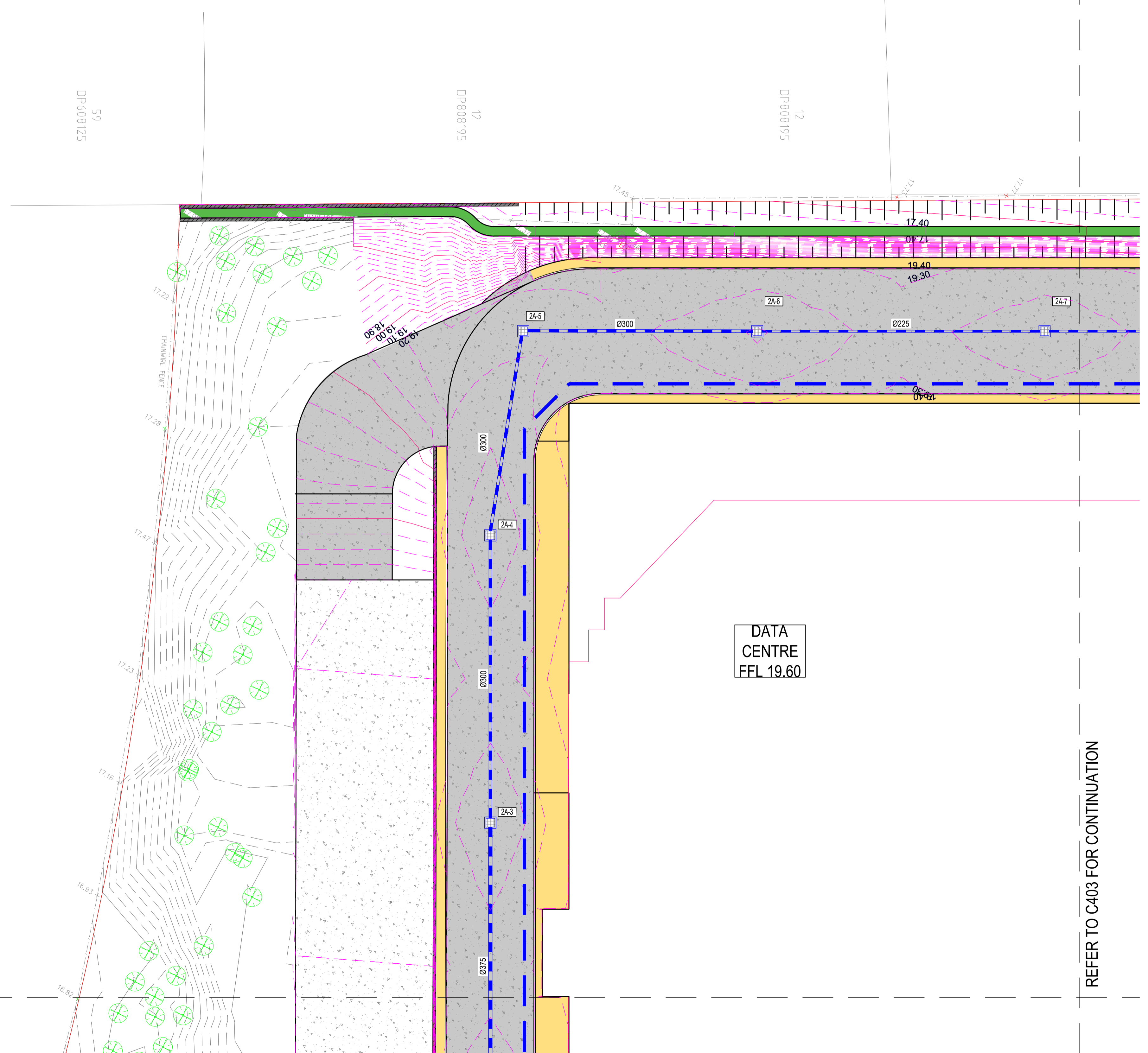

PLAN
SCALE 1:250

REFER TO C401 FOR CONTINUATION

REFER TO C405 FOR CONTINUATION

REFER TO C403 FOR CONTINUATION

REVISIONS:			
No.	REVISION DESCRIPTION	DRAWN	DATE
A	SSDA	VB	12.03.2025

SCALE BAR
0 1 2 3 4 5 10m 15 20m
SCALE 1:250

COPYRIGHT © THIS DRAWING IS THE PROPERTY OF VAN DER MEER CONSULTING PTY LTD. IT MUST NOT BE REPRODUCED, COPIED OR USED WITHOUT THE AUTHORITY OF VAN DER MEER CONSULTING PTY LTD. THIS DRAWING AND ITS CONTENTS ARE ELECTRONICALLY GENERATED. WHERE NECESSARY, DIMENSIONS SHALL TAKE PRECEDENCE OVER DIMENSIONS SHOWN ON THIS DRAWING. VAN DER MEER CONSULTING PTY LTD WILL NOT ACCEPT RESPONSIBILITY FOR ANY CONSEQUENCES ARISING FROM THE USE OF THIS DRAWING FOR OTHER THAN ITS INTENDED PURPOSE OR FOR ANY WORKS OR FABRICATIONS.

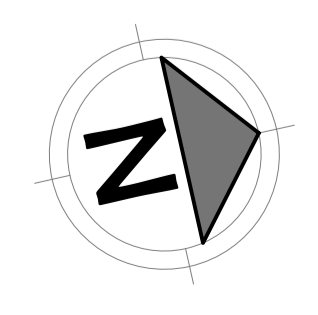

van der Meer Consulting
van der meer
 LEVEL 6, 39 CHANDOS STREET
 ST LEONARDS NSW 2065
 Telephone 61-2-9436 0433 Fax 61-2-9436 1370
 www.vandermeer.com.au
 van der Meer (NSW) Pty Ltd
 A.B.N. 56 158 266 301

CLIENT
GOODMAN PROPERTY SERVICES (AUST) PTY LTD

ARCHITECT
GREENBOX ARCHITECTURE
 LEVEL 22, 68 PITT STREET, SYDNEY NSW 2000

PROJECT TITLE
PROJECT PLUTO
 132 MCCREDIE ROAD
 GUILDFORD WEST NSW 2161

DRAWING TITLE
DRAINAGE PLAN - SHEET 2

DRAWING STATUS			
APPROVAL ISSUE			
NOT TO BE USED FOR CONSTRUCTION			
PROJECT LEADER	DESIGNER	SIGNATURE	
AW	HB/VB		
DRAFTSPERSON	SCALE	DATE DRAWN	SHEET SIZE
HB/VB	1:250		A1
JOB No.	DRAWING No.	REVISION	
SY242-012	SSDA-C402	A	

WARNING

BEWARE OF UNDERGROUND SERVICES
 THE LOCATIONS OF UNDERGROUND SERVICES ARE APPROXIMATE ONLY AND THEIR EXACT POSITION SHOULD BE PROVEN ON SITE. NO GUARANTEE IS GIVEN THAT ALL EXISTING SERVICES ARE SHOWN.

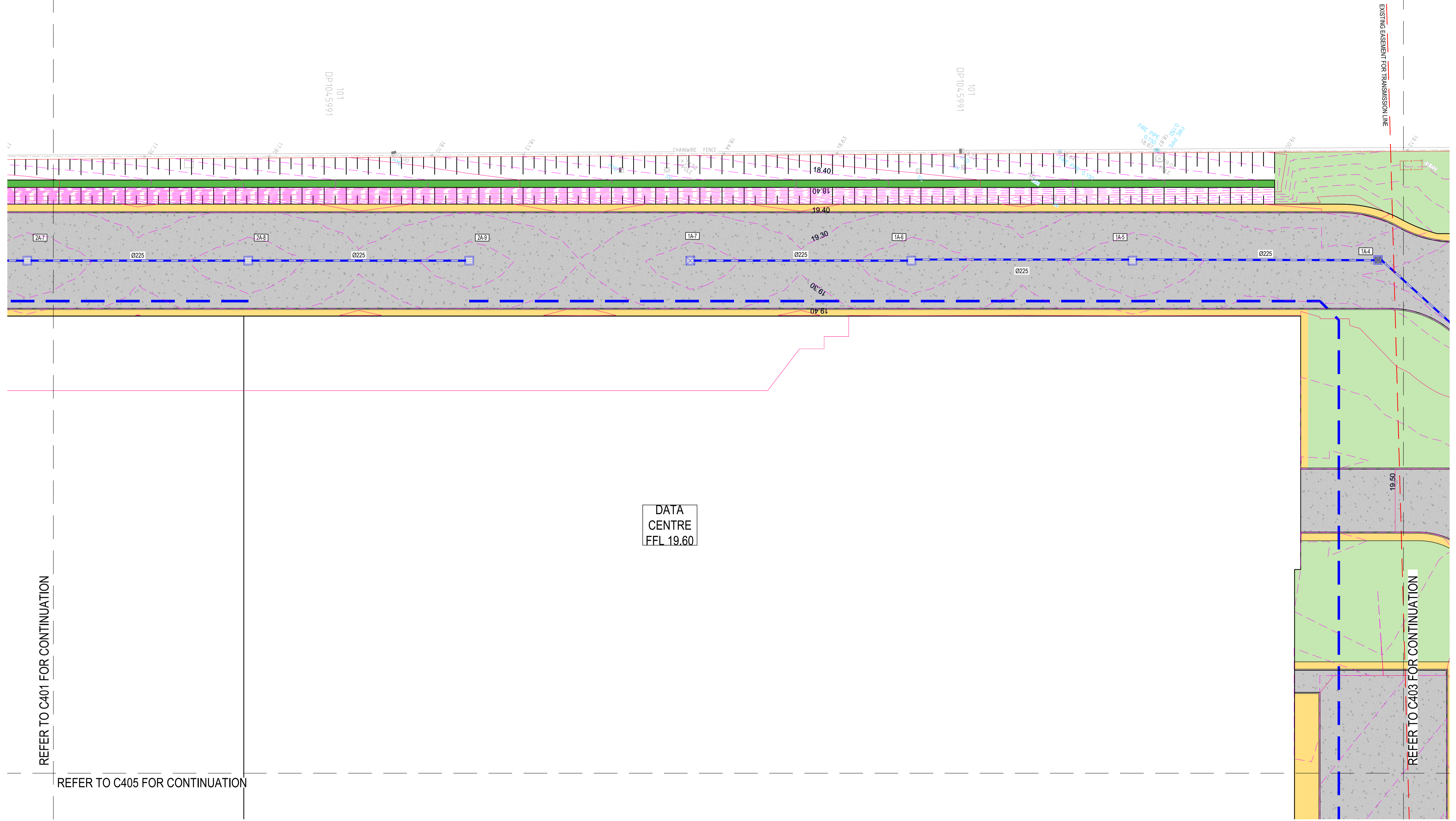

DATA CENTRE
 FFL 19.60

REFER TO C401 FOR CONTINUATION

REFER TO C403 FOR CONTINUATION

REFER TO C405 FOR CONTINUATION

PLAN
 SCALE 1:250

REVISIONS:	
No.	REVISION DESCRIPTION
A	SSDA

SCALE BAR
 0 1 2 3 4 5 10m 15 20m
 SCALE 1:250

COPYRIGHT © THIS DRAWING IS COPYRIGHT AND THE PROPERTY OF VAN DER MEER (NSW) PTY LTD. IT MUST NOT BE REPRODUCED, COPIED OR USED WITHOUT THE AUTHORITY OF VAN DER MEER (NSW) PTY LTD.

DESIGNERS AND/OR CONSULTANTS ARE ELECTRONICALLY GENERATED. THESE DRAWINGS AND ITS CONTENTS ARE ELECTRONICALLY GENERATED. PRECEDENCE OVER SCALED, FIGURED DIMENSIONING TAKE WHICH THEY WERE INTENDED. VAN DER MEER (NSW) PTY LTD WILL NOT ACCEPT RESPONSIBILITY FOR ANY CONSEQUENCES ARISING FROM THE USE OF THE DRAWING FOR OTHER THAN ITS INTENDED PURPOSE OR WHERE THE DRAWING HAS BEEN ALTERED, AMENDED OR CHANGED EITHER MANUALLY OR ELECTRONICALLY BY ANY THIRD PARTY.

THIS IS AN UNCONTROLLED DOCUMENT ISSUED FOR INFORMATION PURPOSES ONLY UNLESS SIGNED. FIGURED DIMENSIONING TAKE PRECEDENCE OVER SCALED. DO NOT SCALE REDUCED SIZE DRAWINGS. VERIFY DIMENSIONS PRIOR TO COMMENCING ANY ON-SITE OR OFF-SITE WORKS OR FABRICATION. IF IN DOUBT - ASK.

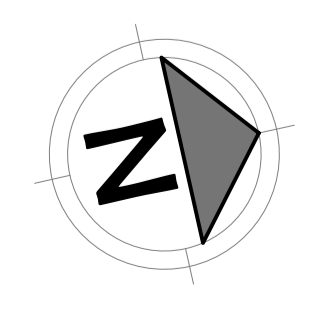

van der Meer Consulting
van der meer

LEVEL 6, 39 CHANDOS STREET
 ST LEONARDS NSW 2065
 Telephone 61-2-9436 0433 Fax 61-2-9436 1370

www.vandermeer.com.au
 van der Meer (NSW) Pty Ltd
 A.B.N. 56 158 266 301

CLIENT
 GOODMAN PROPERTY SERVICES
 (AUST) PTY LTD

ARCHITECT
GREENBOX ARCHITECTURE
 LEVEL 22, 68 PITT STREET, SYDNEY NSW 2000

PROJECT TITLE
 PROJECT PLUTO
 132 MCCREDIE ROAD
 GUILDFORD WEST NSW 2161

DRAWING TITLE
 DRAINAGE PLAN - SHEET 2

DRAWING STATUS			
APPROVAL ISSUE			
NOT TO BE USED FOR CONSTRUCTION			
PROJECT LEADER AW	DESIGNER HB/VB	SIGNATURE	
DRAFTSPERSON HB/VB	SCALE 1:250	DATE DRAWN	SHEET SIZE A1
JOB No. SY242-012	DRAWING No. SSDA-C402	REVISION	A

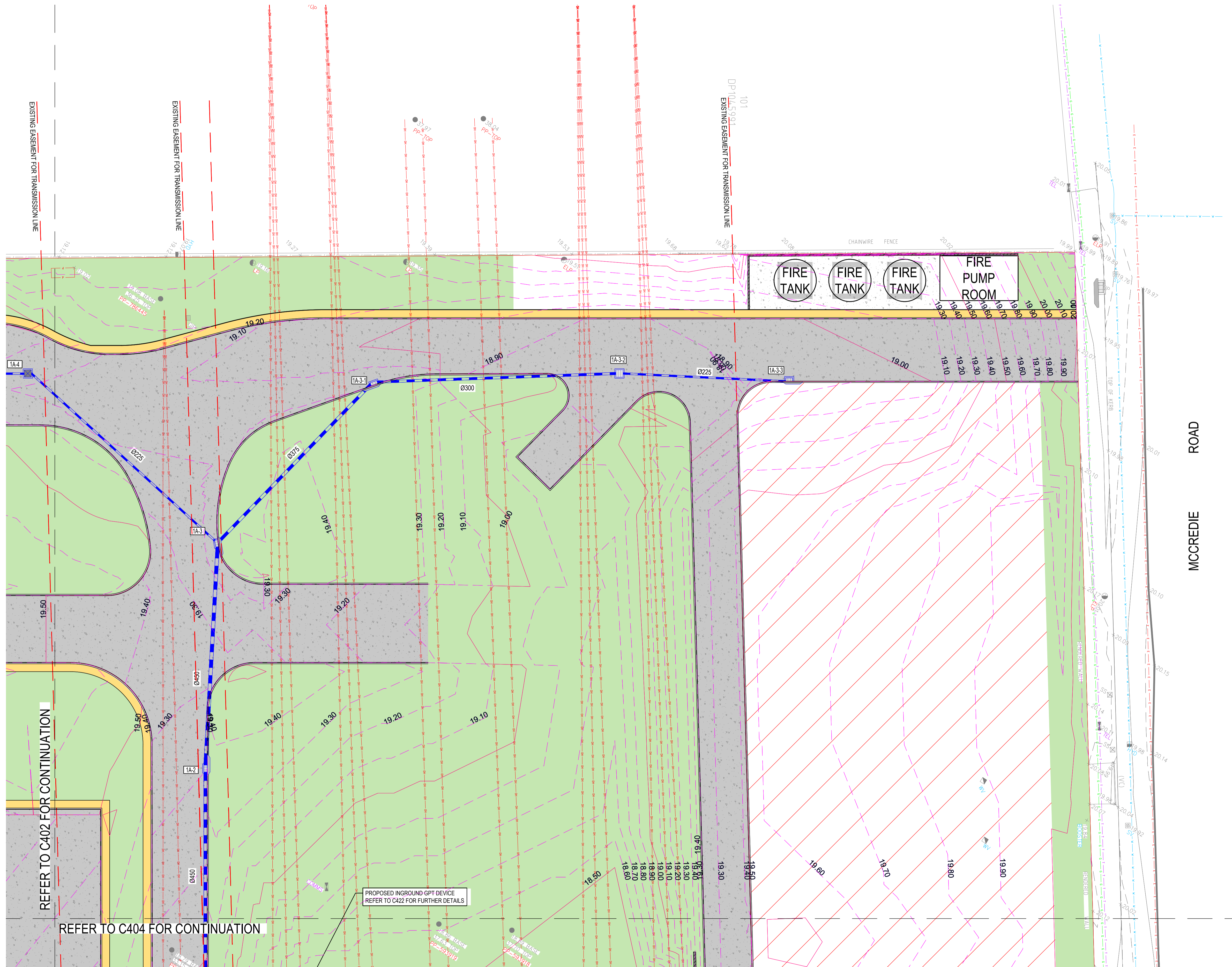

REFER TO C402 FOR CONTINUATION

REFER TO C404 FOR CONTINUATION

PROPOSED INGROUND GPT DEVICE
REFER TO C422 FOR FURTHER DETAILS

PLAN
SCALE 1:250

10
DP1279397

WARNING
BEWARE OF UNDERGROUND SERVICES
THE LOCATIONS OF UNDERGROUND SERVICES ARE APPROXIMATE ONLY AND THEIR EXACT POSITION SHOULD BE PROVEN ON SITE. NO GUARANTEE IS GIVEN THAT ALL EXISTING SERVICES ARE SHOWN.

REVISIONS:	
No.	REVISION DESCRIPTION
A	SSDA

SCALE BAR
0 1 2 3 4 5 10m 15 20m
SCALE 1:250

COPYRIGHT © THE DRAWING IS THE PROPERTY OF VANDERMEER CONSULTING PTY LTD. IT MUST NOT BE REPRODUCED, COPIED OR USED WITHOUT THE AUTHORITY OF VANDERMEER CONSULTING PTY LTD. WHERE THE DRAWING HAS BEEN ALTERED, AMENDED OR CHANGED EITHER MANUALLY OR ELECTRONICALLY BY ANY THIRD PARTY, THIS IS AN UNCONTROLLED DOCUMENT ISSUED FOR INFORMATION PURPOSES ONLY UNLESS SIGNED. FABRIC DIMENSIONS TAKE PRECEDENCE OVER SCALED. DO NOT SCALE REDUCED SIZE DRAWINGS. VERIFY DIMENSIONS PRIOR TO COMMENCING ANY ON-SITE OR OFF-SITE WORKS OR FABRICATION. IF IN DOUBT - ASK.

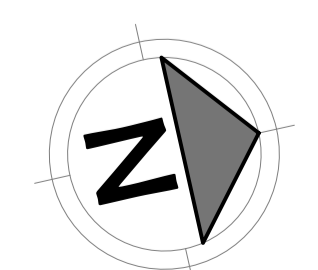

van der Meer Consulting
van der meer
LEVEL 6, 39 CHANDOS STREET
ST LEONARDS NSW 2065
Telephone 61-2-9436 0433 Fax 61-2-9436 1370

www.vandermeer.com.au
van der Meer (NSW) Pty Ltd
A.B.N. 56 158 266 301

CLIENT
GOODMAN PROPERTY SERVICES (AUST) PTY LTD

PROJECT TITLE
PROJECT PLUTO
132 MCCREDIE ROAD
GUILDFORD WEST NSW 2161

ARCHITECT
GREENBOX ARCHITECTURE
LEVEL 22, 68 PITT STREET, SYDNEY NSW 2000

DRAWING STATUS
APPROVAL ISSUE
NOT TO BE USED FOR CONSTRUCTION

PROJECT LEADER AW	DESIGNER HB/VB	SIGNATURE	
DRAFTSPERSON HB/VB	SCALE 1:250	DATE DRAWN	SHEET SIZE A1
JOB No. SY242-012	DRAWING No. SSDA-C403	REVISION A	

1596315
2

REFER TO C401 FOR CONTINUATION

REFER TO C405 FOR CONTINUATION

DATA CENTRE
FEL 19.60

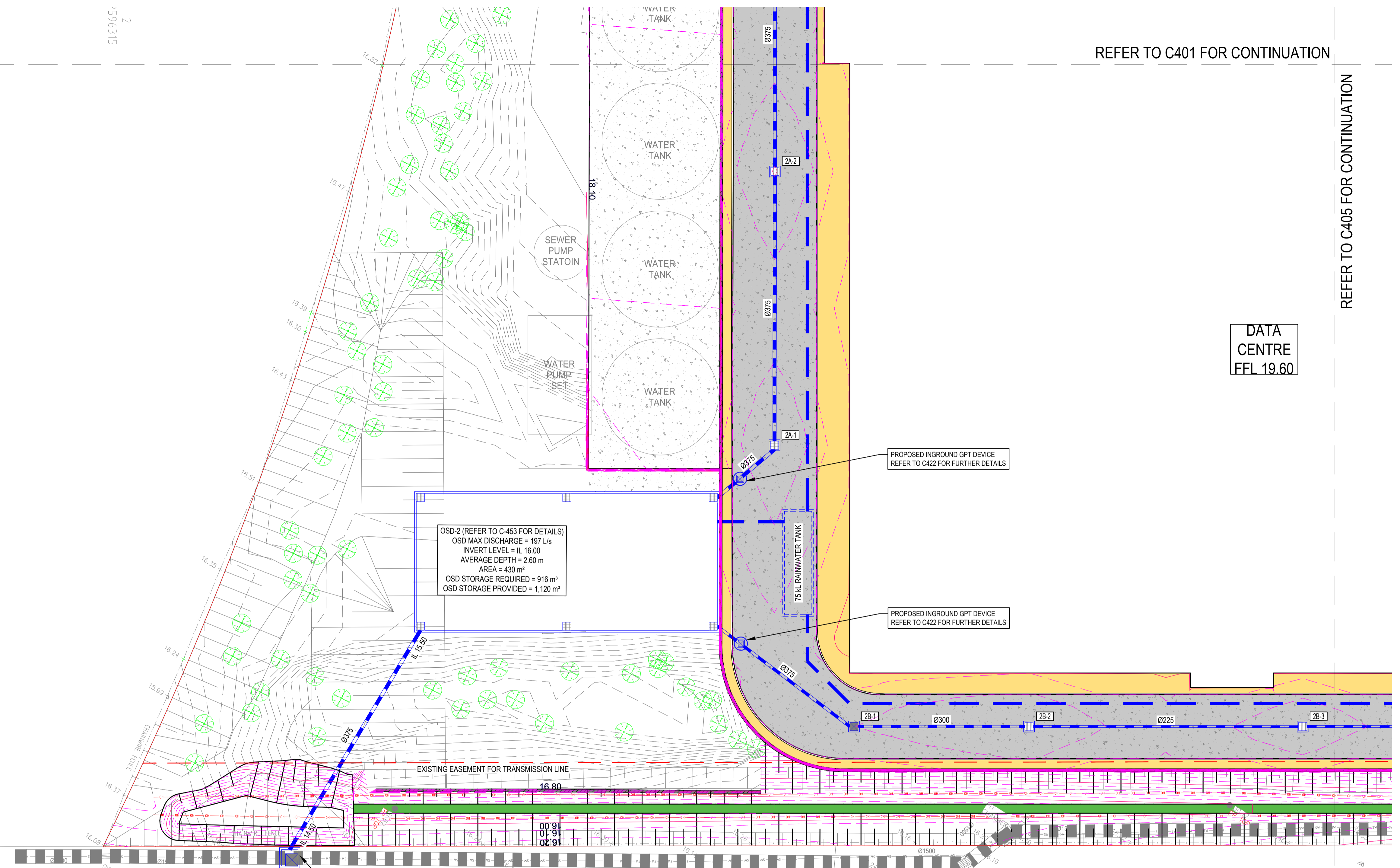

PLAN
SCALE 1:250

WARNING
BEWARE OF UNDERGROUND SERVICES
THE LOCATIONS OF UNDERGROUND SERVICES ARE APPROXIMATE ONLY AND THEIR EXACT POSITION SHOULD BE PROVEN ON SITE. NO GUARANTEE IS GIVEN THAT ALL EXISTING SERVICES ARE SHOWN.

REVISIONS:	
No.	REVISION DESCRIPTION
A	SSDA

SCALE BAR
0 1 2 3 4 5 10m 15 20m
SCALE 1:250

van der Meer Consulting
van der Meer (NSW) Pty Ltd
LEVEL 6, 39 CHANDOS STREET
ST LEONARDS NSW 2065
Telephone 61-2-9436 0433 Fax 61-2-9436 1370

van der Meer
www.vandermeer.com.au
van der Meer (NSW) Pty Ltd
A.B.N. 56 158 266 301

van der Meer Consulting
van der Meer (NSW) Pty Ltd
LEVEL 6, 39 CHANDOS STREET
ST LEONARDS NSW 2065
Telephone 61-2-9436 0433 Fax 61-2-9436 1370

van der Meer
www.vandermeer.com.au
van der Meer (NSW) Pty Ltd
A.B.N. 56 158 266 301

CLIENT
GOODMAN PROPERTY SERVICES (AUST) PTY LTD

PROJECT TITLE
PROJECT PLUTO
132 MCCREDIE ROAD
GUILDFORD WEST NSW 2161

ARCHITECT
GREENBOX ARCHITECTURE
LEVEL 22, 68 PITT STREET, SYDNEY NSW 2000

DRAWING STATUS
APPROVAL ISSUE
NOT TO BE USED FOR CONSTRUCTION

PROJECT LEADER
AW

DESIGNER
HB/VB

SIGNATURE

DRAFTSPERSON
HB/VB

SCALE
1:250

DATE DRAWN

SHEET SIZE
A1

JOB No.
SY242-012

DRAWING No.
SSDA-C404

REVISION
A

CLIENT
GOODMAN PROPERTY SERVICES (AUST) PTY LTD

PROJECT TITLE
PROJECT PLUTO
132 MCCREDIE ROAD
GUILDFORD WEST NSW 2161

ARCHITECT
GREENBOX ARCHITECTURE
LEVEL 22, 68 PITT STREET, SYDNEY NSW 2000

DRAWING TITLE
DRAINAGE PLAN - SHEET 4

REFER TO C402 FOR CONTINUATION

REFER TO C404 FOR CONTINUATION

DATA
CENTRE
FEL 19.60

REFER TO C406 FOR CONTINUATION

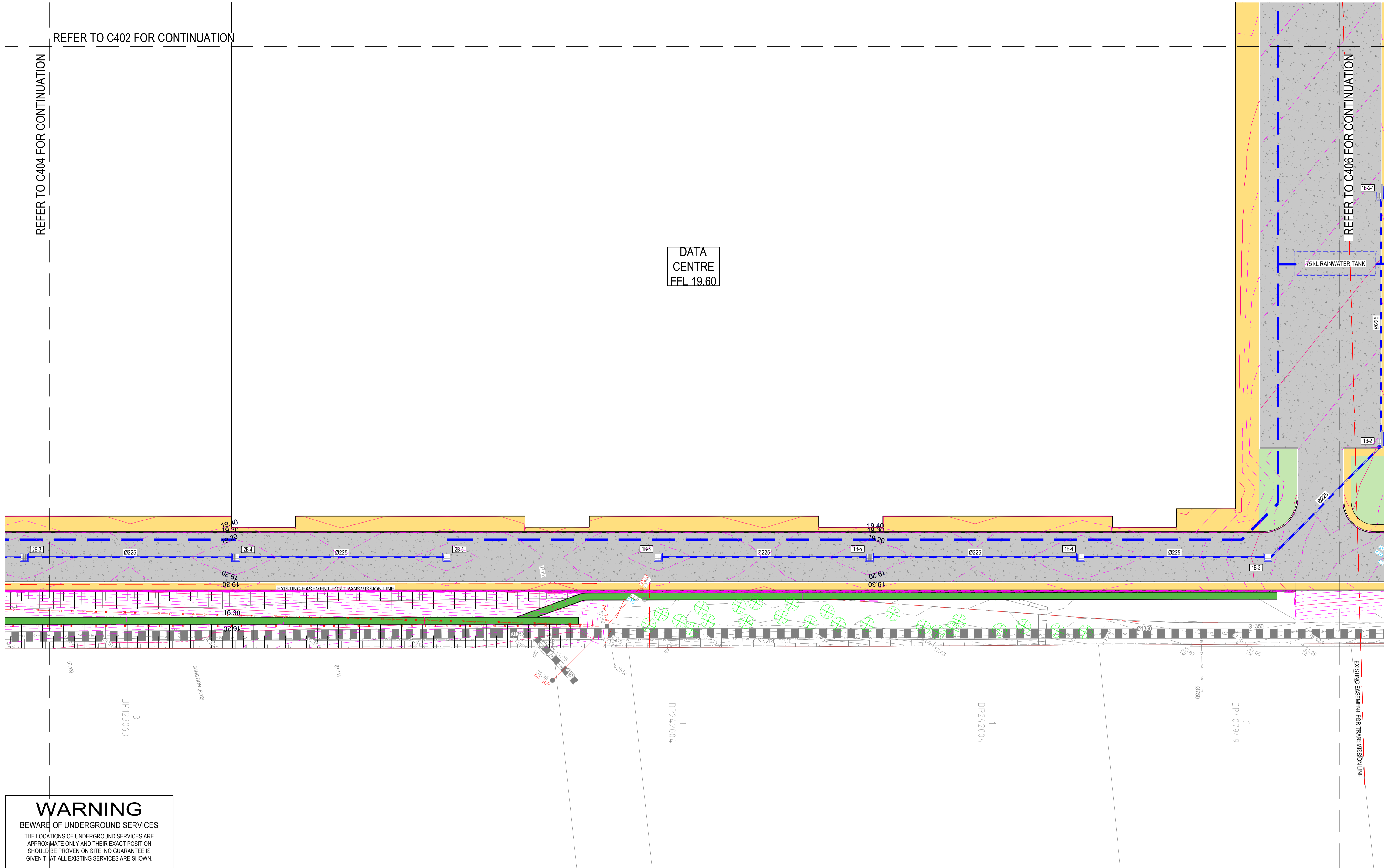

PLAN
SCALE 1:250

WARNING
BEWARE OF UNDERGROUND SERVICES
THE LOCATIONS OF UNDERGROUND SERVICES ARE APPROXIMATE ONLY AND THEIR EXACT POSITION SHOULD BE PROVEN ON SITE. NO GUARANTEE IS GIVEN THAT ALL EXISTING SERVICES ARE SHOWN.

REVISIONS:	
No.	REVISION DESCRIPTION
A	SSDA

SCALE BAR
0 1 2 3 4 5 10m 15 20m
SCALE 1:250

van der Meer Consulting
van der Meer (NSW) Pty Ltd
LEVEL 6, 39 CHANDOS STREET
ST LEONARDS NSW 2065
Telephone 61-2-9436 0433 Fax 61-2-9436 1370

van der Meer
www.vandermeer.com.au
van der Meer (NSW) Pty Ltd
A.B.N. 56 158 266 301

WHERE THE DRAWING HAS BEEN ALTERED, AMENDED OR CHANGED EITHER MANUALLY OR ELECTRONICALLY BY ANY THIRD PARTY, THIS IS AN UNCONTROLLED DOCUMENT ISSUED FOR INFORMATION PURPOSES ONLY UNLESS SIGNED. FIGURES DIMENSIONING TAKE PRECEDENCE OVER SCALED. DO NOT SCALE REDUCED SIZE DRAWINGS. VERIFY DIMENSIONS PRIOR TO COMMENCING ANY ON-SITE OR OFF-SITE WORKS OR FABRICATION. IF IN DOUBT - ASK.

van der Meer Consulting
van der Meer (NSW) Pty Ltd
LEVEL 6, 39 CHANDOS STREET
ST LEONARDS NSW 2065
Telephone 61-2-9436 0433 Fax 61-2-9436 1370

van der Meer
www.vandermeer.com.au
van der Meer (NSW) Pty Ltd
A.B.N. 56 158 266 301

CLIENT
GOODMAN PROPERTY SERVICES (AUST) PTY LTD

ARCHITECT
GREENBOX ARCHITECTURE
LEVEL 22, 68 PITT STREET, SYDNEY NSW 2000

PROJECT TITLE
PROJECT PLUTO
132 MCCREDIE ROAD
GUILDFORD WEST NSW 2161

DRAWING TITLE
DRAINAGE PLAN - SHEET 5

DRAWING STATUS
APPROVAL ISSUE
NOT TO BE USED FOR CONSTRUCTION

PROJECT LEADER AW	DESIGNER HB/VB	SIGNATURE
DRAFTSPERSON HB/VB	SCALE 1:250	DATE DRAWN
JOB No. SY242-012	DRAWING No. SSDA-C405	SHEET SIZE A1
		REVISION A

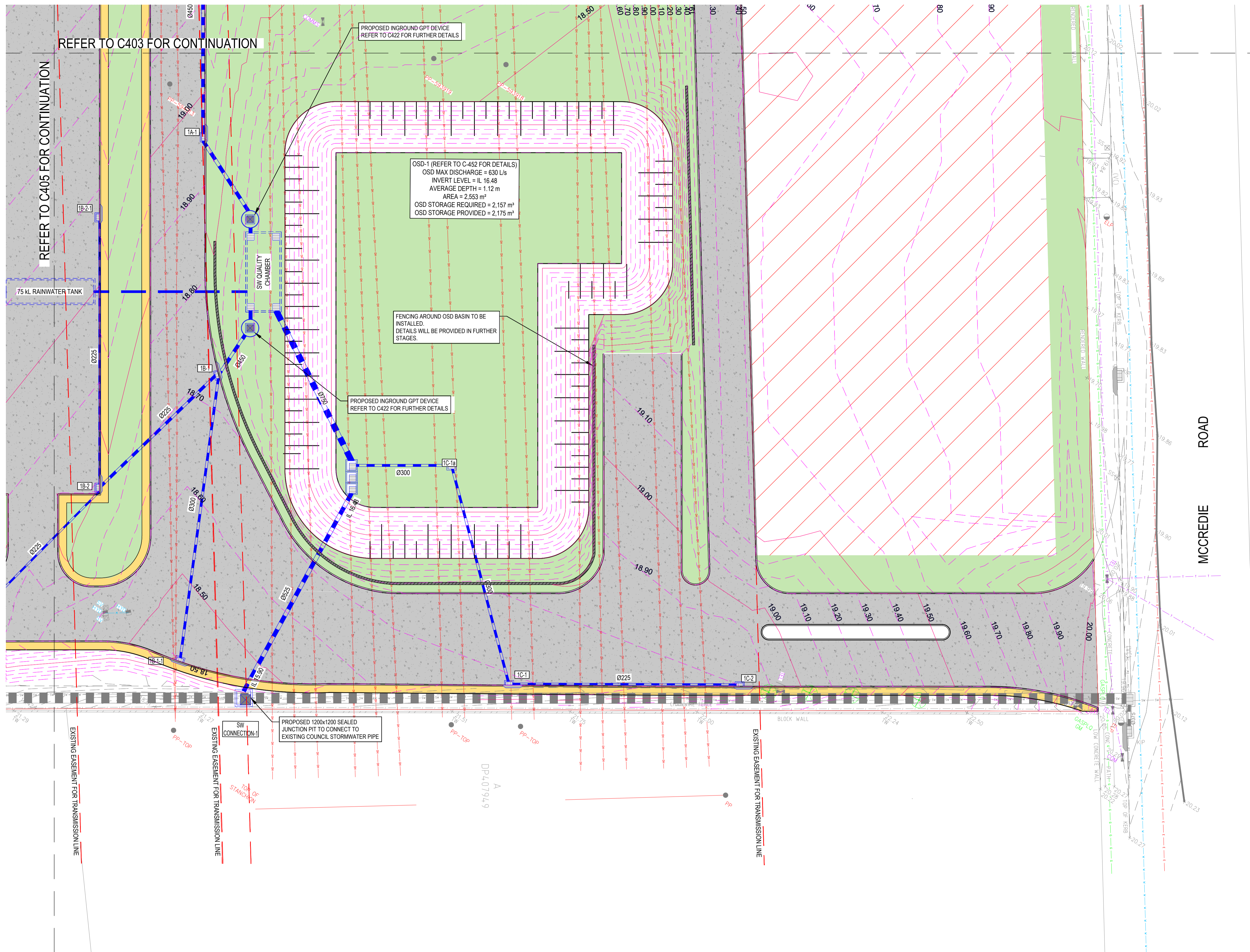

PLAN
SCALE 1:250

WARNING
BEWARE OF UNDERGROUND SERVICES
THE LOCATIONS OF UNDERGROUND SERVICES ARE APPROXIMATE ONLY AND THEIR EXACT POSITION SHOULD BE PROVEN ON SITE. NO GUARANTEE IS GIVEN THAT ALL EXISTING SERVICES ARE SHOWN.

REVISIONS:	REVISION DESCRIPTION	DATE
A	SSDA	12.03.2025

SCALE BAR
0 1 2 3 4 5 10m 15 20m
SCALE 1:250

COPYRIGHT © THE DRAWING IS COPYRIGHT AND THE PROPERTY OF VANDER MEER (NSW) PTY LTD. IT MUST NOT BE REPRODUCED, COPIED OR USED WITHOUT THE AUTHORITY OF VANDER MEER (NSW) PTY LTD.
THE DRAWING AND ITS CONTENTS ARE ELECTRONICALLY GENERATED, ARE CONFIDENTIAL AND MAY ONLY BE USED FOR THE PURPOSE FOR WHICH THEY WERE INTENDED. VANDER MEER (NSW) PTY LTD. WILL NOT ACCEPT RESPONSIBILITY FOR ANY CONSEQUENCES ARISING FROM THE USE OF THE DRAWING FOR OTHER THAN ITS INTENDED PURPOSE OR WHERE THE DRAWING HAS BEEN ALTERED, AMENDED OR CHANGED EITHER MANUALLY OR ELECTRONICALLY BY ANY THIRD PARTY.
THIS IS AN UNCONTROLLED DOCUMENT ISSUED FOR INFORMATION PURPOSES ONLY UNLESS SIGNED. FIGURES DIMENSIONING TAKE PRECEDENCE OVER SCALES. DO NOT SCALE REDUCED SIZE DRAWINGS. VERIFY DIMENSIONS PRIOR TO COMMENCING ANY ON SITE OR OFF-SITE WORKS OR FABRICATION. IF IN DOUBT - ASK.

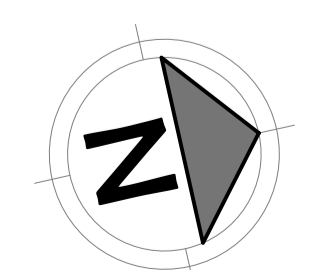







van der Meer Consulting
van der meer
LEVEL 6, 39 CHANDOS STREET
ST LEONARDS NSW 2065
Telephone 61-2-9436 0433 Fax 61-2-9436 1370
www.vandermeer.com.au
van der Meer (NSW) Pty Ltd
A.B.N. 56 158 266 301

CLIENT
GOODMAN PROPERTY SERVICES (AUST) PTY LTD
ARCHITECT
GREENBOX ARCHITECTURE
LEVEL 22, 68 PITT STREET, SYDNEY NSW 2000

PROJECT TITLE
PROJECT PLUTO
132 MCCREDIE ROAD
GUILDFORD WEST NSW 2161
DRAWING TITLE
DRAINAGE PLAN - SHEET 6

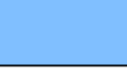
DRAWING STATUS			
APPROVAL ISSUE			
NOT TO BE USED FOR CONSTRUCTION			
PROJECT LEADER AW	DESIGNER HB/VB	SIGNATURE	
DRAFTSPERSON HB/VB	SCALE 1:250	DATE DRAWN	SHEET SIZE A1
JOB No. SY242-012	DRAWING No. SSDA-C406	REVISION	A

LEGEND		
SITE AREA: 71,700 m ²		
	* EXISTING NATURAL SURFACE (0% IMPERVIOUSNESS)	4,168 m ²
NORTHERN OSD SUBCATCHMENT: 47,402 m ²		
	ROOF AREA RWT & OSD 1:	18,435m ²
	SURFACE AREA TO OSD 1:	26,495 m ²
	BYPASS AREA	2,472 m ²
SOUTHERN OSD SUBCATCHMENT: 20,130m ²		
	ROOF AREA TO RWT & OSD 2:	10,349 m ²
	SURFACE AREA TO OSD 2:	7,241m ²
	BYPASS AREA	2,540m ²

* NOTE: EXISTING NATURAL SURFACE AREA IS LOWER THAN THE PROPOSED DEVELOPMENT AND IT WILL BE RETAINED AS EXISTING AND EXCLUDED FROM THE OSD CALCULATION
TOTAL SITE BYPASS AREA IS 6,003m² THAT IS 8% OF THE TOTAL SITE AREA.

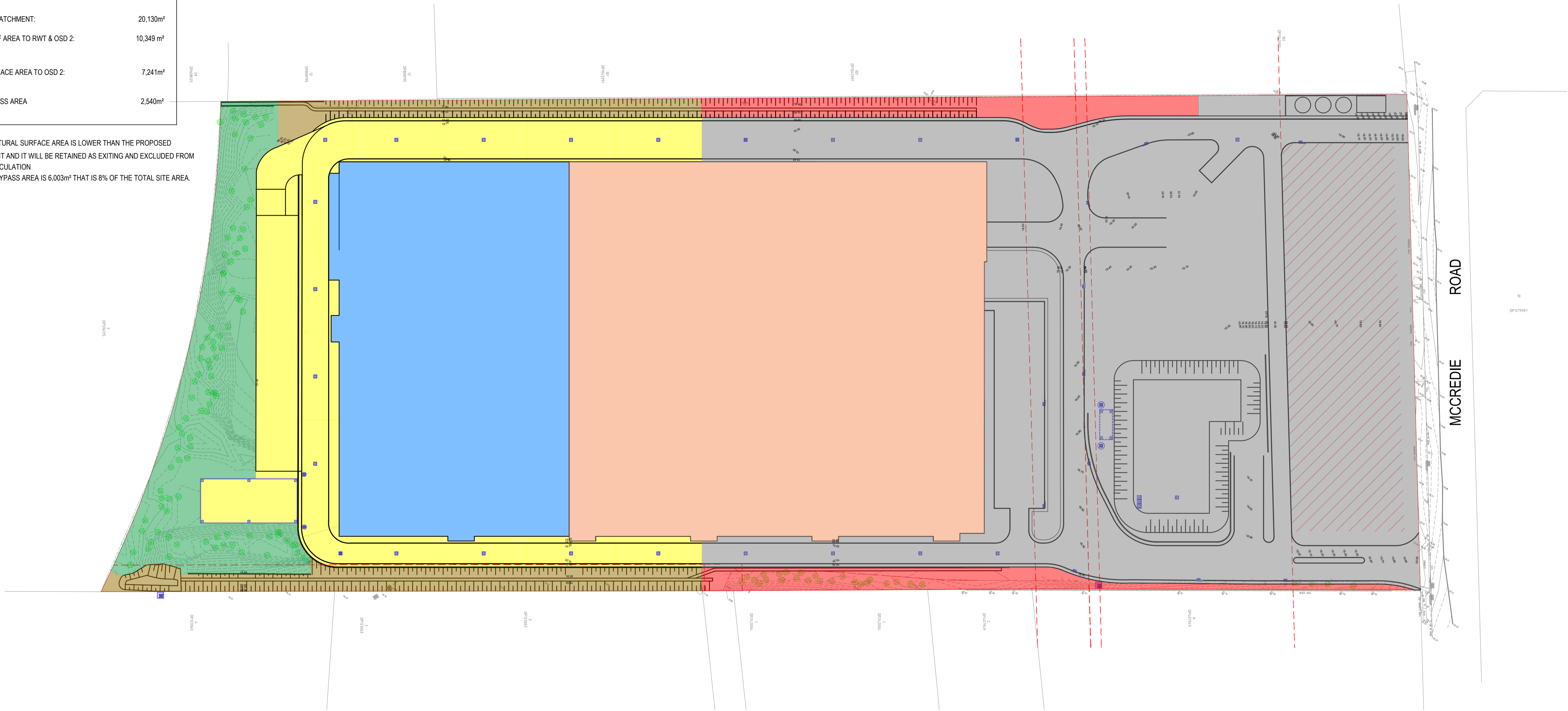

PLAN
SCALE 1:750

REVISIONS:			
No.	REVISION DESCRIPTION	DRAWN	DATE
A	SSDA	VB	12.03.2025

SCALE BAR
0 10 20 30 40 50m 75m
SCALE 1:750

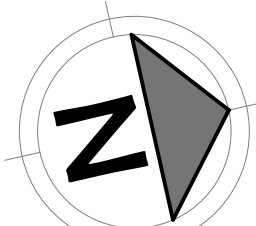

COPYRIGHT © THE DRAWING IS COPYRIGHT AND THE PROPERTY OF VAN DER MEER (NSW) PTY LTD. IT MUST NOT BE RETAINED, COPIED OR USED WITHOUT THE AUTHORITY OF VAN DER MEER (NSW) PTY LTD.
DISCLAIMER: THIS DRAWING AND ITS CONTENTS ARE ELECTRONICALLY GENERATED, ARE CONFIDENTIAL AND MAY ONLY BE USED FOR THE PURPOSE FOR WHICH THEY WERE INTENDED. VAN DER MEER (NSW) PTY LTD. WILL NOT ACCEPT RESPONSIBILITY FOR ANY CONSEQUENCES ARISING FROM THE USE OF THE DRAWING FOR OTHER THAN ITS INTENDED PURPOSE OR WHERE THE DRAWING HAS BEEN ALTERED, AMENDED OR CHANGED EITHER MANUALLY OR ELECTRONICALLY BY ANY THIRD PARTY.
NOTE: THIS IS AN UNCONTROLLED DOCUMENT ISSUED FOR INFORMATION PURPOSES ONLY UNLESS SIGNED. FIGURES DIMENSIONING TAKE PRECEDENCE OVER SCALED. DO NOT SCALE REDUCED SIZE DRAWINGS. VERIFY DIMENSIONS PRIOR TO COMMENCING ANY ON-SITE OR OFF-SITE WORKS OR FABRICATION. IF IN DOUBT - ASK.

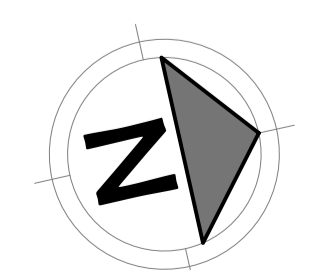

van der Meer Consulting
van der meer

LEVEL 6, 39 CHANDOS STREET
ST LEONARDS NSW 2065
Telephone 61-2-9436 0433 Fax 61-2-9436 1370

www.vandermeer.com.au
van der Meer (NSW) Pty Ltd
A.B.N. 56 158 266 301

CLIENT
GOODMAN PROPERTY SERVICES (AUST) PTY LTD







ARCHITECT
GREENBOX ARCHITECTURE
LEVEL 22, 68 PITT STREET, SYDNEY NSW 2000

PROJECT TITLE
PROJECT PLUTO
132 MCCREDIE ROAD
GUILDFORD WEST NSW 2161

DRAWING TITLE
DRAINS CATCHMENT PLAN

DRAWING STATUS
APPROVAL ISSUE
NOT TO BE USED FOR CONSTRUCTION

PROJECT LEADER AW	DESIGNER HB/VB	SIGNATURE	
DRAFTSPERSON HB/VB	SCALE 1:750	DATE DRAWN	SHEET SIZE A1
JOB No. SY242-012	DRAWING No. SSDA-C421	REVISION A	

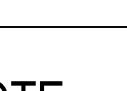
LEGEND		
SITE AREA:	71,700 m ²	
	* EXISTING NATURAL SURFACE (0% IMPERVIOUSNESS)	9,180m ²
	ROOF AREA TO RWT AND WSUD CHAMBER: (100% IMPERVIOUSNESS)	18,435m ²
	SURFACE AREA TO STORMSACKS (70% IMPERVIOUSNESS)	2,156m ²
	SEALED ROADS TO GPT & WSUD CHAMBER: (80% IMPERVIOUSNESS)	10,201 m ²
	SURFACE AREA TO OSD 1 (30% IMPERVIOUSNESS)	14,112m ²
	ROOF AREA TO RWT AND WSUD CHAMBER: (100% IMPERVIOUSNESS)	10,349 m ²
	UNSEALED ROAD TO GPT & WSUD CHAMBER: (90% IMPERVIOUSNESS)	6,733m ²
	OSD TANK YARD (100% IMPERVIOUSNESS)	534m ²

* NOTE: EXISTING NATURAL SURFACE AREA IS LOWER THAN THE PROPOSED DEVELOPMENT AND IT WILL BE RETAINED AS EXISTING AND EXCLUDED FROM THE WATER QUALITY TREATMENT

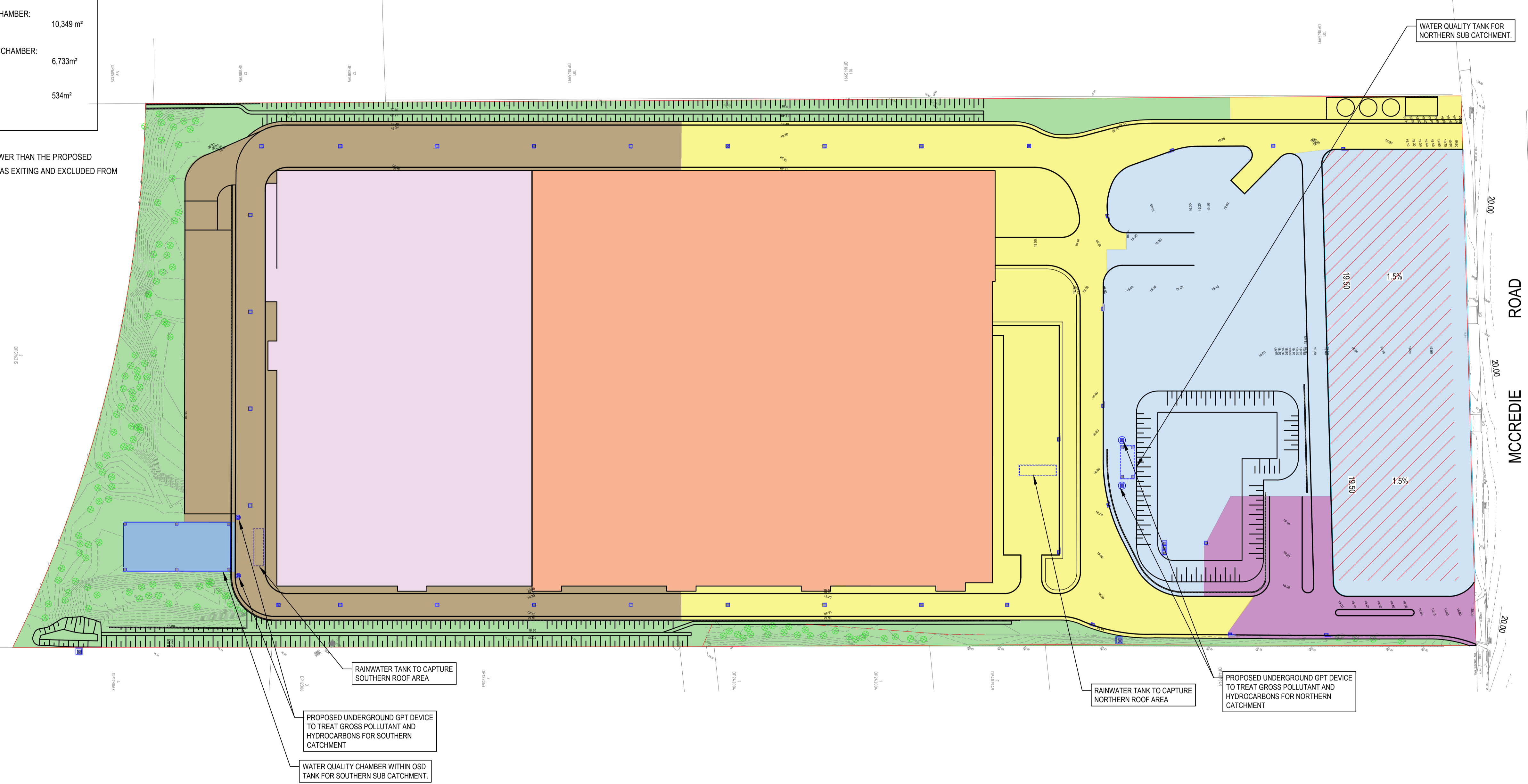

PLAN
SCALE 1:750

REVISIONS:			
No.	REVISION DESCRIPTION	DRAWN	DATE
A	SSDA	VB	12.03.2025

SCALE BAR
0 10 20 30 40 50m 75m
SCALE 1:750

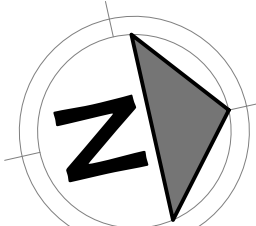

COPYRIGHT © THE DRAWING IS COPYRIGHT AND THE PROPERTY OF VANDER MEER (NSW) PTY LTD. IT MUST NOT BE RETAINED, COPIED OR USED WITHOUT THE AUTHORITY OF VANDER MEER (NSW) PTY LTD. THESE DIMENSIONS ARE ELECTRONICALLY GENERATED. PRECEDENCE OVER SCALED, FIGURED DIMENSIONS TAKE EFFECT. VANDER MEER (NSW) PTY LTD WILL NOT ACCEPT RESPONSIBILITY FOR ANY CONSEQUENCES ARISING FROM THE USE OF THE DRAWING FOR OTHER THAN ITS INTENDED PURPOSE OR WHERE THE DRAWING HAS BEEN ALTERED, AMENDED OR CHANGED EITHER MANUALLY OR ELECTRONICALLY BY ANY THIRD PARTY. THIS IS AN UNCONTROLLED DOCUMENT ISSUED FOR INFORMATION PURPOSES ONLY. UNLESS SIGNED, FIGURED DIMENSIONS TAKE PRECEDENCE OVER SCALED. DO NOT SCALE REDUCED SIZE DRAWINGS. VERIFY DIMENSIONS PRIOR TO COMMENCING ANY ON-SITE OR OFF-SITE WORKS OR FABRICATION. IF IN DOUBT - ASK.

 van der Meer Consulting

van der meer

LEVEL 6, 39 CHANDOS STREET
ST LEONARDS NSW 2065
Telephone 61-2-9436 0433 Fax 61-2-9436 1370

www.vandermeer.com.au
van der Meer (NSW) Pty Ltd
A.B.N. 56 158 266 301

CLIENT
GOODMAN PROPERTY SERVICES (AUST) PTY LTD

ARCHITECT
GREENBOX ARCHITECTURE
LEVEL 22, 68 PITT STREET, SYDNEY NSW 2000

PROJECT TITLE
PROJECT PLUTO
132 MCCREDIE ROAD
GUILDFORD WEST NSW 2161

DRAWING TITLE
MUSIC CATCHMENT PLAN

DRAWING STATUS			
APPROVAL ISSUE			
NOT TO BE USED FOR CONSTRUCTION			
PROJECT LEADER	DESIGNER	SIGNATURE	
AW	HB/VB		
DRAFTSPERSON	SCALE	DATE DRAWN	SHEET SIZE
HB/VB	1:750		A1
JOB No.	DRAWING No.	REVISION	
SY242-012	SSDA-C422	A	

APPENDIX B- WATER QUALITY DEVICE DETAILS



AUCKLAND
L8, 139 Quay St
Auckland NZ

BRISBANE
L3, 51 Alfred St
Fortitude Valley

CANBERRA
L9, 2 Phillip Law St
Canberra

MELBOURNE
L6, 379 Collins St
Melbourne

NEWCASTLE
L1, 17 Bolton St
Newcastle

SYDNEY
L6, 39 Chandos St
St Leonards



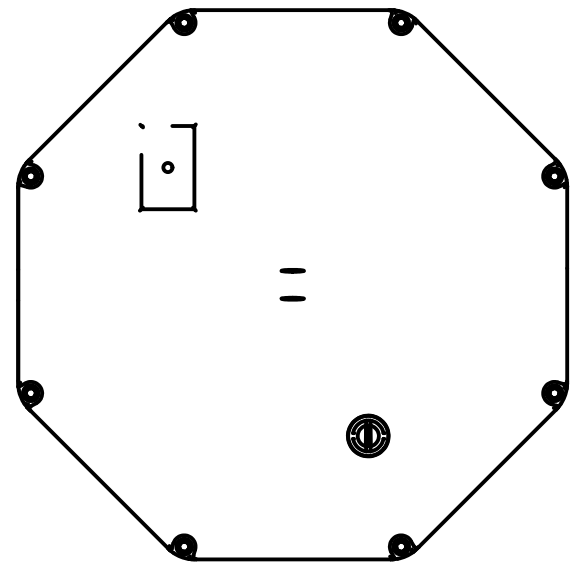

PLAN VIEW

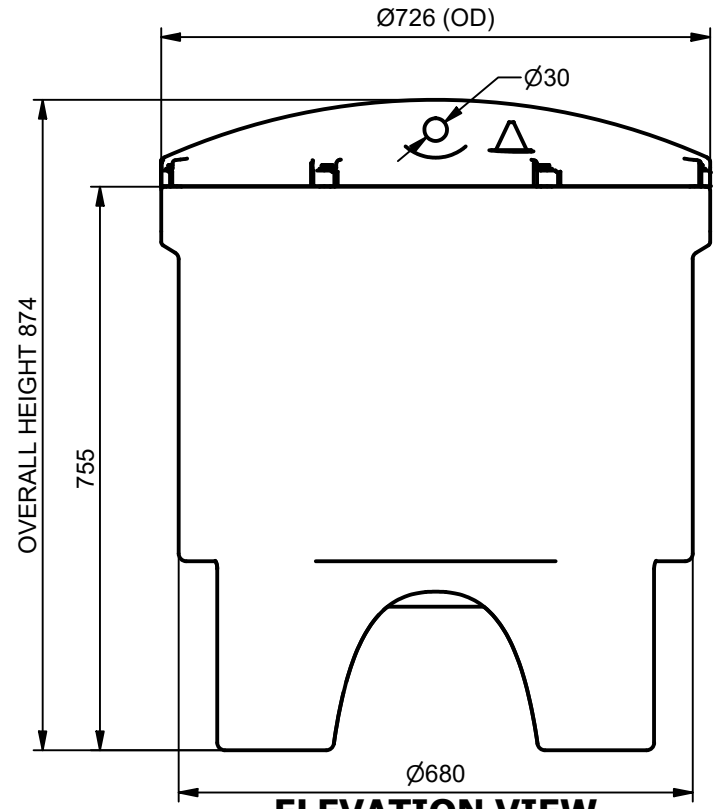

ELEVATION VIEW

AIR RELEASE VALVE

POLY LID

FILTER BODY

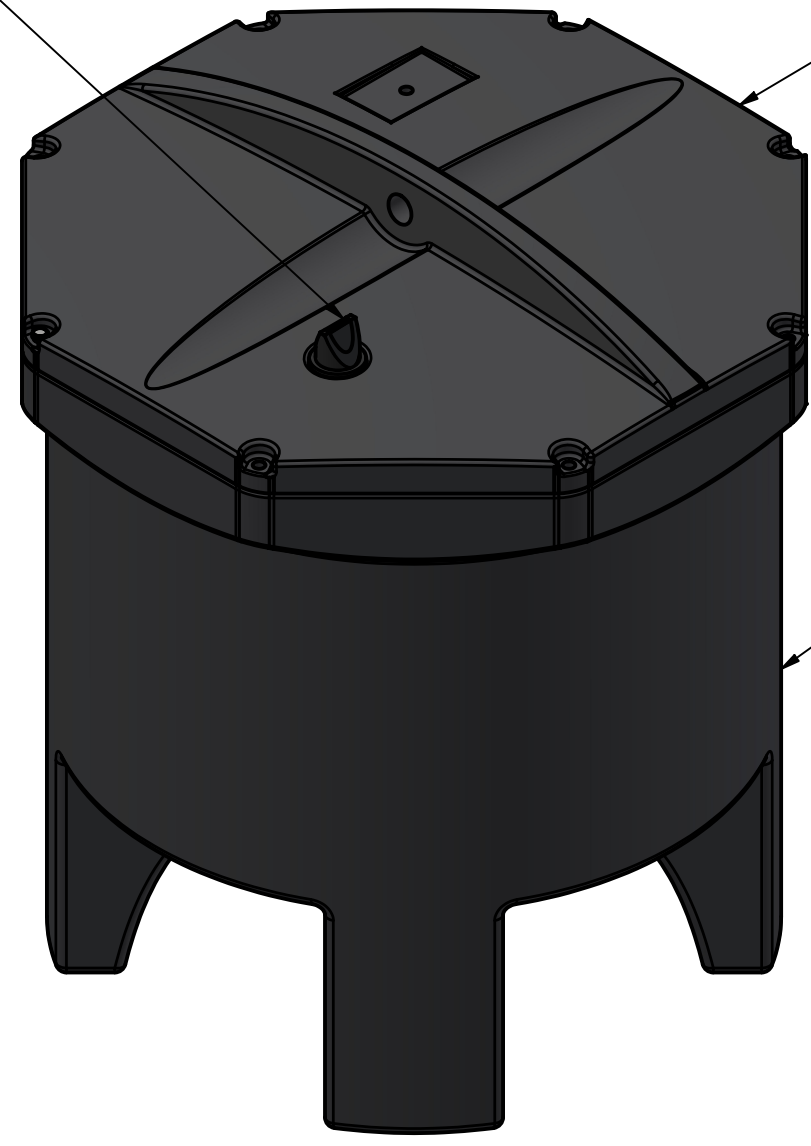

TOLERANCE: All Dimensions to Closest 10 mm & +/- 30 mm | **ALL INTERCONNECTING PIPEWORK, PITS AND ASSOCIATED DRAINAGE BY OTHERS**

1	08/04/2024	R.J.	INITIAL RELEASE	
REV	DATE	BY	DESCRIPTION	CHK

CLIENT:

CONFIDENTIAL - The drawings must not be disclosed to any third parties without written permission from ATLAN STORMWATER . Unauthorized disclosure may result in prosecution.
 © ATLAN STORMWATER - This drawing is the property of ATLAN STORMWATER ABN: 83 151 832 629 and is subject to return on demand. It is submitted for the use only in connection with the proposal and contracts of ATLAN STORMWATER with the expressed conditions that it is not to be reproduced or copied in any form. This data must only be used in accordance with our standard terms and conditions.
 © Copyright
 ATLAN STORMWATER accepts no responsibility for any loss or damage resulting from any person acting on this information. The details and dimensions contained in this document may change, please check with ATLAN STORMWATER for confirmation of current specifications.

Drawn	Date
R.J.	08/04/2024
Check	Date
Verified	Date
Approved	Date
Request No.	



PROJECT :			
TITLE			
ATLANFILTER MODEL : FIL-3.0 GENERAL ARRANGEMENT			
SCALE	SIZE	SHEET	REV
N.T.S	A3	1	1
CUSTOMER CODE :		DWG No.	
FIL-3.0			

C:\Users\smart\OneDrive\Documents\Vault\Designs\ATLAN01 - STANDARDS\ATLAN FILTER\FIL-3.0\ENC\M\FIL-3.0.dwg



-
- Sizing, siting and design of all GPTs
 - Stormwater harvesting design and construction
 - Construction of stormwater devices
 - GPT auditing and WSUD auditing
 - Rectifications of stormwater devices
 - O&M of stormwater harvesting
 - Stormwater DA designs
 - Project management and training

11th May 2020
Our Ref: 18D40

Blacktown City Council

Attention: Mark Liebman

Dear Mark,

RE: Equivalency of the Vortceptor to the CDS Unit Gross Pollutant Trap

We refer to the following SPEL Vortceptor models:

Off-Line Models

- SVO.1600
- SVO.1200
- SVO.810
- SVO.800
- SVO.530
- SVO.360
- SVO.220
- SVO.180
- SVO.140
- SVO.096

In-Line Models;

- SVI.055M
- SVI.055
- SVI.025

Optimal Stormwater have assessed the shop drawings and detailed drawings (valid up to 11/5/2020) and believe that SPEL has now achieved equivalence in functionality to the Rocla CDS unit range based on the following:

- Equivalent inlet dimensions to maintain velocities for rotation and self-cleaning of the screen;
- Equivalent screen area compared to the Rocla CDS unit range;
- Equivalent stainless-steel screens;
- Identical expanded mesh screen and opening;



- Outlet dimensions sufficient for the flow rates expected (capacity flow rates);
- Equivalent sump volumes;
- A shear cone at the base of the screen to cut off the rotation and reduce the risk for resuspension of solids stored in the sump area; and
- Sufficient access for maintenance of the GPT.

The designer will still need to consider weir heights and hydraulic bypass arrangements suitable for the catchment and existing drainage networks to ensure acceptable hydraulic conditions. However, Optimal Stormwater has sighted typical drawing details of an appropriate diversion chamber design and connection from the weir to the device and connection flange to the diversion chamber. Sizing of the Vortceptor should be based on the catchment characteristics and flow rate to be treated in accordance with SPEL sizing guides and appropriate relevant industry standards. It is the responsibility of the designer to double check the suitability of the Vortceptor for the specific application.

The designer will need to consider the buoyancy forces associated with the installation, as the Vortceptor is significantly less in weight compared to the CDS Unit.

If the GPT is to be grab cleaned, then SPEL advises that a reinforced concrete layer can be cast across the floor of the sump, to protect the integrity of the sump base when being impacted by the steel grab bucket. This addition would make it equivalent in regards to this form of cleaning.

We acknowledge the extent of product development over the past 12 months to achieve a device that is technically equivalent in functionality to the CDS Unit, and it can claim “Continuous Deflection Separation Technology” has been achieved.

Kind regards,

Murray Powell,
For and on behalf of, Optimal Stormwater Pty Ltd

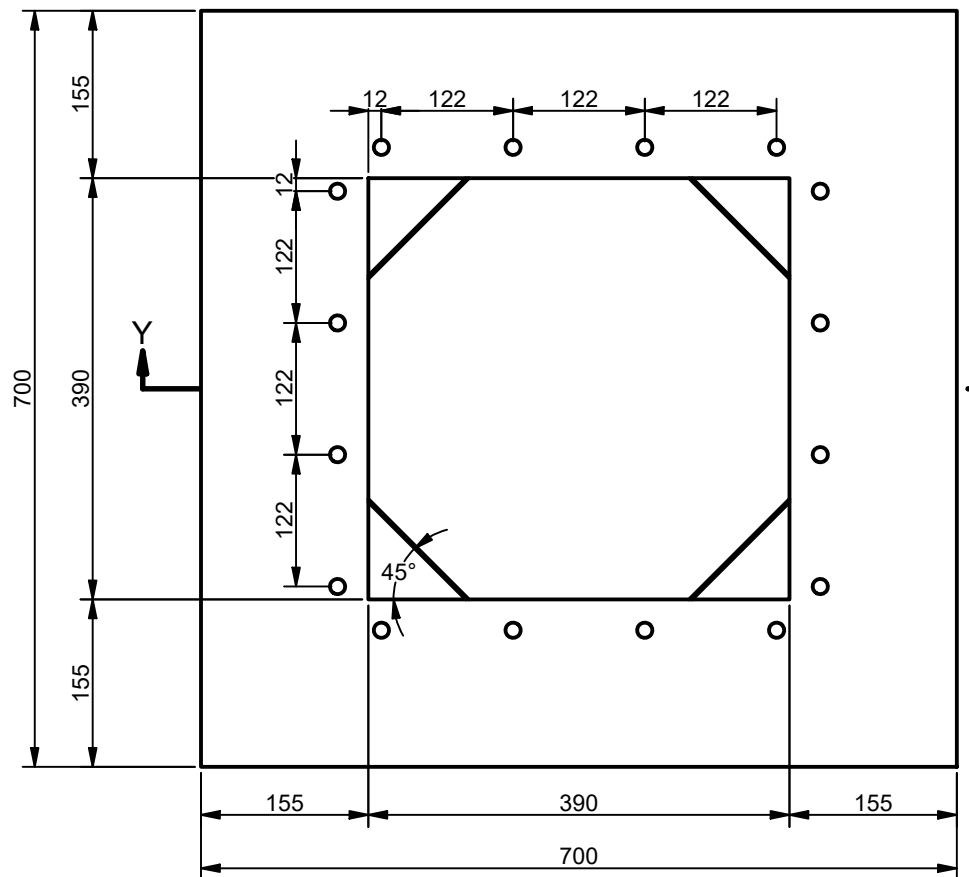

PLAN VIEW

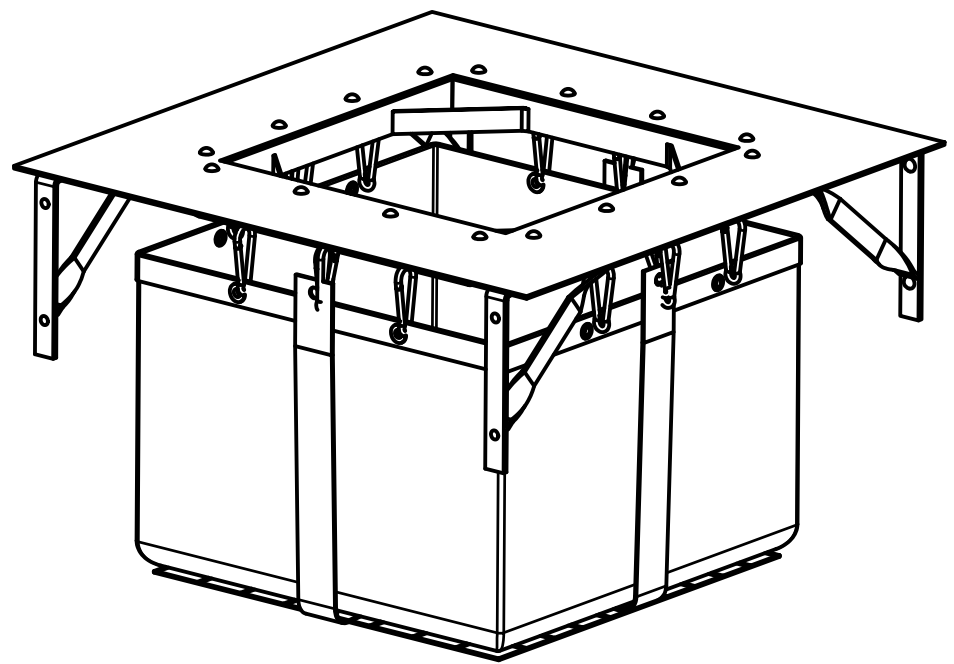

ISOMETRIC VIEW

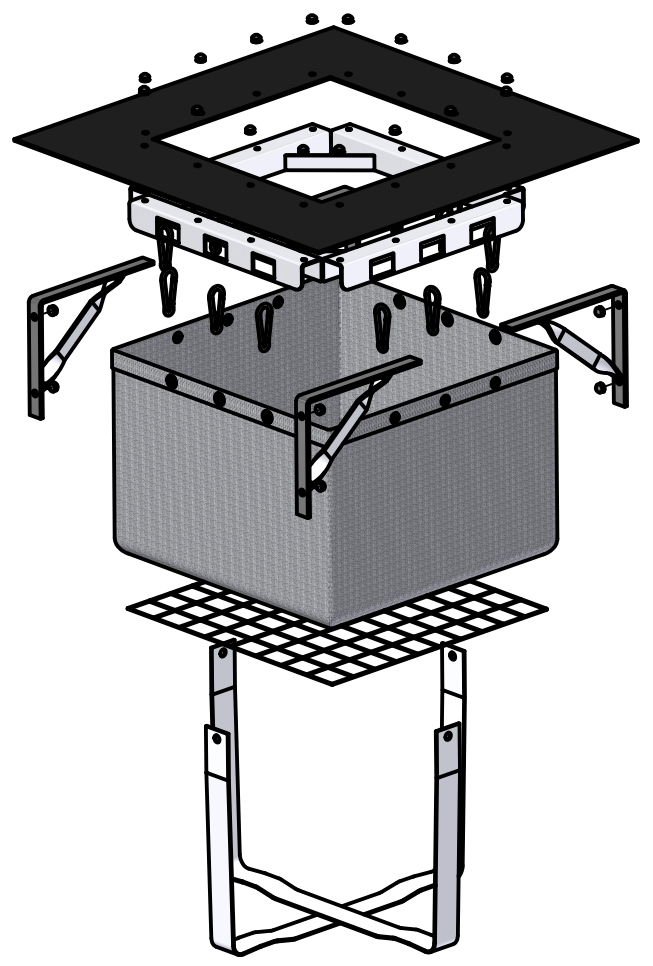

**ISOMETRIC VIEW
EXPLOSION**

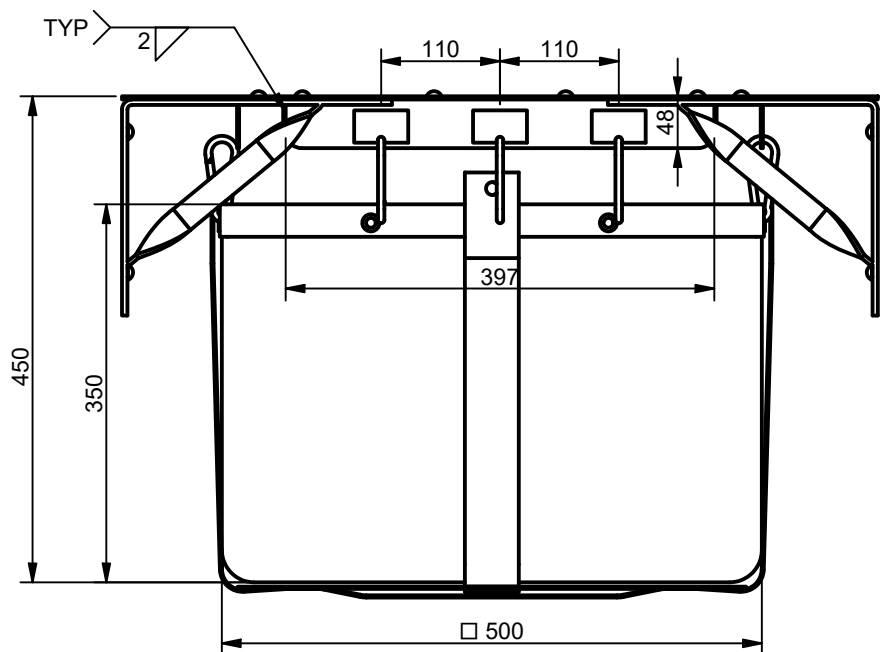

ELEVATION VIEW

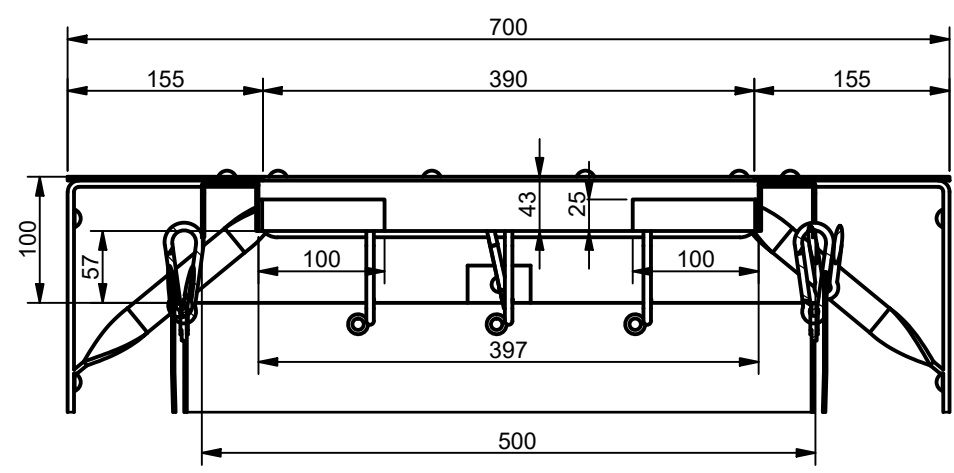

SECTION Y-Y

TOLERANCE: All Dimensions to Closest 10 mm & +/- 30 mm | **ALL INTERCONNECTING PIPEWORK, PITS AND ASSOCIATED DRAINAGE BY OTHERS**

1		19/04/2024	R.J.	INITIAL RELEASE	
REV	DATE	BY	DESCRIPTION	CHK	

CLIENT:

CONFIDENTIAL - The drawings must not be disclosed to any third parties without written permission from ATLAN STORMWATER. Unauthorized disclosure may result in prosecution.
 © ATLAN STORMWATER - This drawing is the property of ATLAN STORMWATER ABN: 83 151 832 629 and is subject to return on demand. It is submitted for the use only in connection with the proposal and contracts of ATLAN STORMWATER with the expressed conditions that it is not to be reproduced or copied in any form. This data must only be used in accordance with our standard terms and conditions.
 © Copyright
 ATLAN STORMWATER accepts no responsibility for any loss or damage resulting from any person acting on this information. The details and dimensions contained in this document may change, please check with ATLAN STORMWATER for confirmation of current specifications.

Drawn	Date
R.J.	19/04/2024
Check	Date
Verified	Date
Approved	Date
Request No.	



PROJECT :			
TITLE			
ATLAN STORMSACK STS.6060.C1 GENERAL ARRANGEMENT			
SCALE	SIZE	SHEET	REV
N.T.S	A3	1	1
CUSTOMER CODE :		DWG No.	
		STS.6060.C1	

C:\Users\smart\OneDrive\Documents\Vault\Designs\ATLAN01 - STANDARDS\STORMSACK\STS.6060.C1\STS.6060.C1.dwg

3rd March 25

Van Der Meer Consulting
39 Chandos St, St Leonards NSW 2065

Attention:

Re: Vortceptor Hydrocarbon Removal

Dear Vahid,

This letter confirms the total petroleum hydrocarbon and free oil reduction performance of the Vortceptor GPT. The Vortceptor Gross Pollutant Trap (GPT) is a non-blocking vortex style separator with a unique screen and treatment action that produces low vortex conditions, resulting in excellent pollution removal performance and high water quality outcomes.

The stated petroleum hydrocarbon removal for the Vortceptor is 94%, which is inline with the testing completed – refer to *The CDS Unit for Removal of Oil and Grease (2012)*. Free oil removal is expected to be higher than petroleum hydrocarbon due to its non-dissolved nature.



Oscar Bentham
Civil & Environmental Engineer
for and on behalf of
Atan Stormwater

RIGHT SIDE INFLOW

REVISION HISTORY				
REV	DESCRIPTION	DESIGNER	CREATION DA	CHECKED BY
1	INITIAL RELEASE	M.MAKIN	20/06/2018	

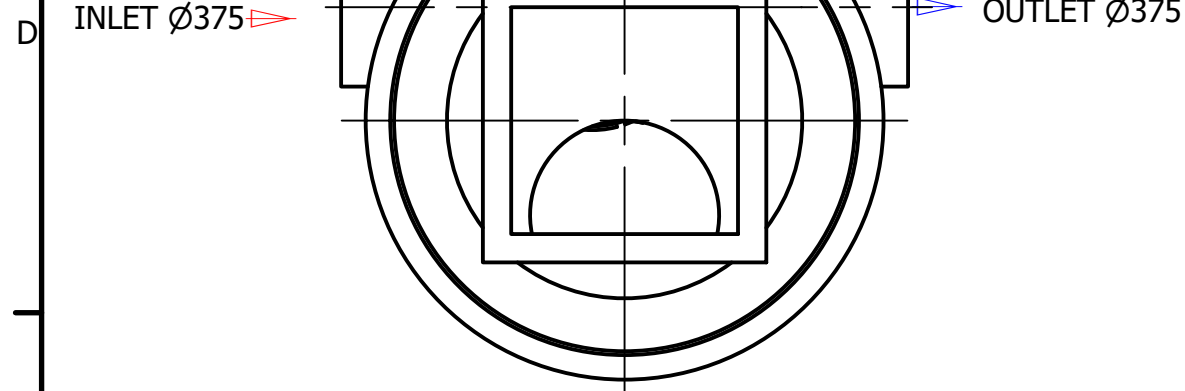

PLAN VIEW

Site Level Confirmation	
Finished Surface Level (FSL) RL:	
Access Cover Thickness	mm
Inlet Invert Level RL:	
Outlet Invert Level RL:	
Company:	
Name:	
Date:	



ISOMETRIC VIEW

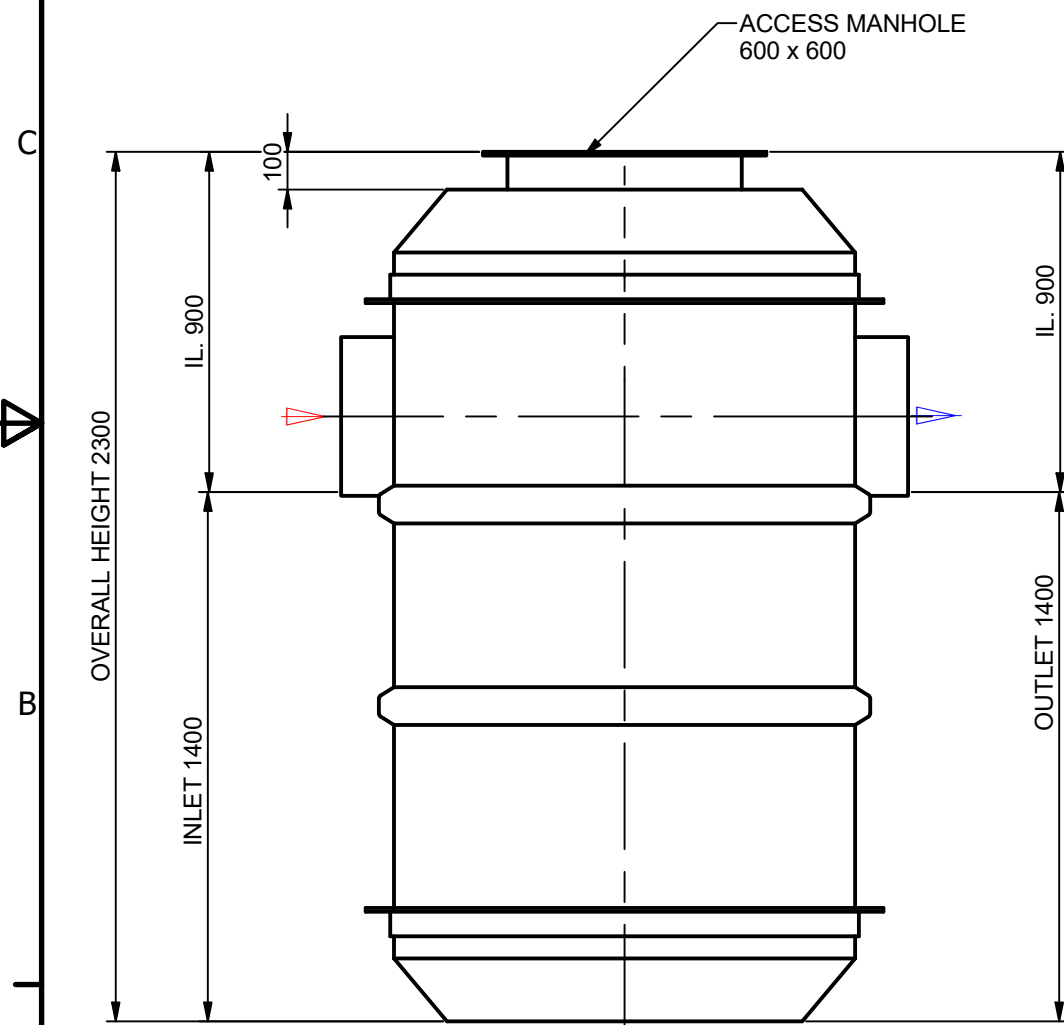

ELEVATION VIEW

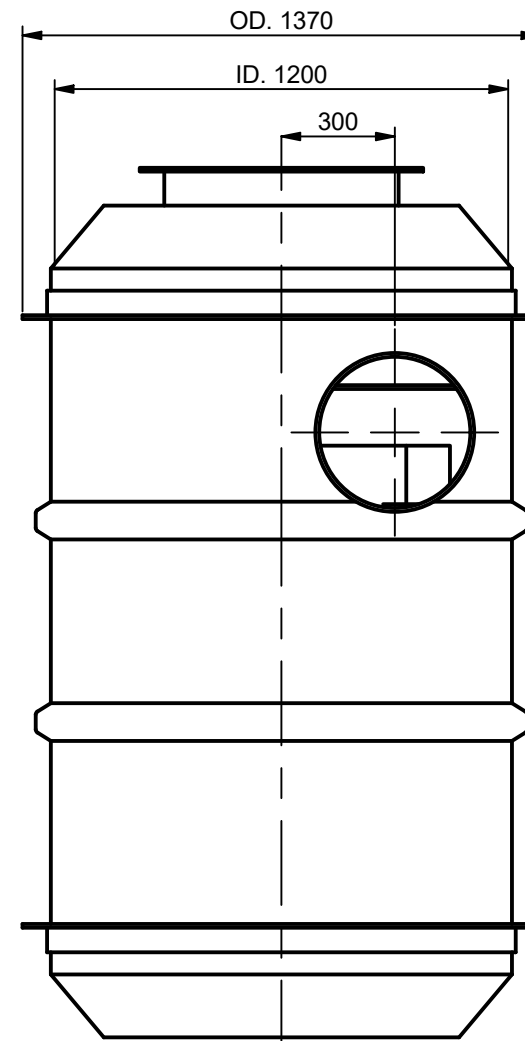

SIDE VIEW

TOLERANCE: ALL DIMENSIONS 10mm UNLESS OTHERWISE STATED.

ALL INTERCONNECTING PIPEWORK, PITS AND ASSOCIATED DRAINAGE BY OTHERS

CLIENT:

DISTRIBUTOR :

CONFIDENTIAL - The drawings must not be disclosed to any third parties without written permission from SPEL Environmental Sydney. Unauthorised disclosure may result in prosecution.
 © SPEL Environmental - This drawing is the property of SPEL Environmental ABN: 83 151 832 629 and is subject to return on demand. It is submitted for the use only in connection with the proposal and contracts of SPEL Environmental with the expressed conditions that it is not to be reproduced or copied in any form. This data must only be used in accordance with our standard terms and conditions.
 © Copyright
 SPEL Environmental accepts no responsibility for any loss or damage resulting from any person acting on this information. The details and dimensions contained in this document may change, please check with SPEL Environmental for confirmation of current specifications.

Drawn	Date
M.MAKIN	20/06/2018
Check	Date
Verified	Date
Approved	Date
Request No.	RN4922



PROJECT :			
TITLE SPELVORTCEPTOR SVI.025.L.375.PVC GENERAL ARRANGEMENTS			
SCALE	N.T.S	SIZE	A3
SHEET	1	REV	1
CUSTOMER CODE :		DWG No. SP17-VC41700-S	

E:\Vault Working Folder\Designs\SPEL\PRODUCTS\VORTCEPTOR\LINE SVI.025\STANDARD\LEFT SIDE-375\SP17-VC41700-S.dwg

RIGHT SIDE INFLOW

REVISION HISTORY				
REV	DESCRIPTION	DESIGNER	CREATION DA	CHECKED BY
1	INITIAL RELEASE	M.MAKIN	6/02/2019	

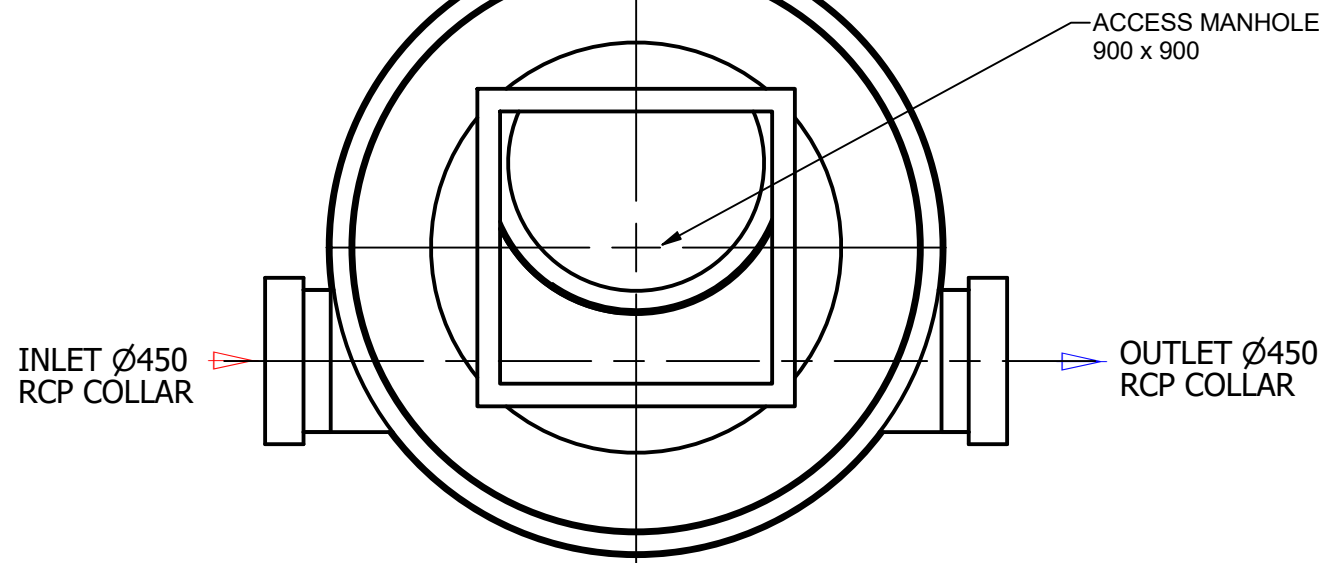

PLAN VIEW

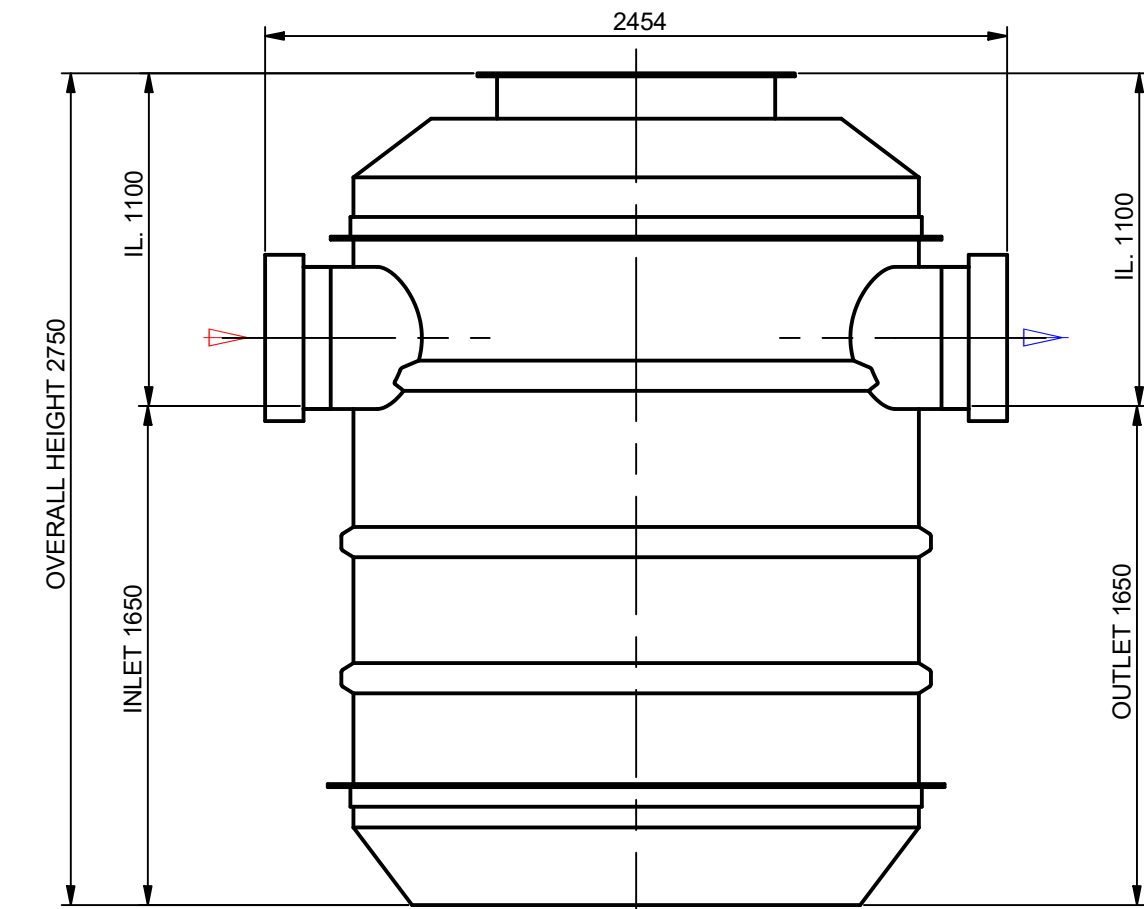

ELEVATION VIEW

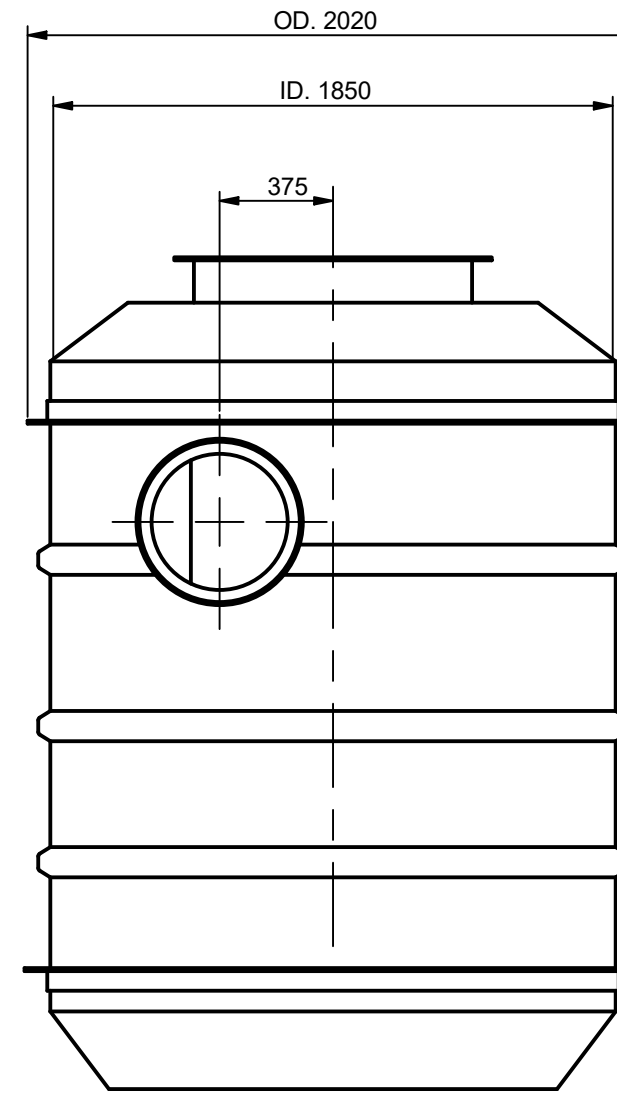

ELEVATION VIEW



ISOMETRIC VIEW

TOLERANCE: ALL DIMENSIONS 10mm UNLESS OTHERWISE STATED.

ALL INTERCONNECTING PIPEWORK, PITS AND ASSOCIATED DRAINAGE BY OTHERS

CLIENT:

DISTRIBUTOR :

CONFIDENTIAL - The drawings must not be disclosed to any third parties without written permission from SPEL Environmental Sydney. Unauthorised disclosure may result in prosecution.
 © SPEL Environmental - This drawing is the property of SPEL Environmental ABN: 83 151 832 629 and is subject to return on demand. It is submitted for the use only in connection with the proposal and contracts of SPEL Environmental with the expressed conditions that it is not to be reproduced or copied in any form. This data must only be used in accordance with our standard terms and conditions.
 © Copyright
 SPEL Environmental accepts no responsibility for any loss or damage resulting from any person acting on this information. The details and dimensions contained in this document may change, please check with SPEL Environmental for confirmation of current specifications.

Drawn	Date
M.MAKIN	6/02/2019
Check	Date
Verified	Date
Approved	Date
Request No.	
	RN4045



PROJECT :			
TITLE SPELVORTCEPTOR SVI.055.L.450.RCP GENERAL ARRANGEMENT			
SCALE	N.T.S	SIZE	A3
SHEET	1	REV	1
CUSTOMER CODE :		DWG No. SP19-SV10750-S	

E:\Vault Working Folder\Designs\SPEL\PRODUCTS\VORTCEPTOR\INLINE\SVI.055\STANDARD-LEFT-450\SP19-SV10750-S.dwg