



BLACKETT
MAGUIRE+
GOLDSMITH

BCA ASSESSMENT REPORT

**Oakdale South
Horsley Park**

Client: Goodman Property Services

Revision 2

Date: 14.07.2016

Project No.: 150226



Address

Suite 2.01,
22-36 Mountain St
Ultimo NSW 2007

Contact

Ph: 02 9211 7777
Fax: 02 9211 7774



CONTENTS

A.	INTRODUCTION	3
A.1	BACKGROUND / PROPOSAL	3
A.2	AIM	3
A.3	PROJECT TEAM	3
A.4	DOCUMENTATION	3
A.5	REGULATORY FRAMEWORK	4
A.6	LIMITATIONS & EXCLUSIONS	4
A.7	TERMINOLOGY	4
B.	BUILDING CHARACTERISTICS	6
B.1	BUILDING CLASSIFICATION	6
B.2	FIRE SOURCE FEATURE	ERROR! BOOKMARK NOT DEFINED.
C.	BCA ASSESSMENT	7
C.1	BCA DEEMED-TO-SATISFY COMPLIANCE ISSUES:	7
	SECTION C – FIRE RESISTANCE	7
	SECTION D – ACCESS & EGRESS	10
	SECTION E – SERVICES AND EQUIPMENT	17
	SECTION F – HEALTH & AMENITY	19
	SECTION J – ENERGY EFFICIENCY	21
C.	CONCLUSION	22

REPORT STATUS				
DATE	REVISION	STATUS	AUTHOR	REVIEWED
21/08/2015	0	Preliminary Assessment – For DA submission	DG	TH
29/06/2016	1	Updated Assessment – Precinct 1 Masterplan Submission	DG	TH
14/07/2016	2	Updated drawings	DG	TH

Prepared by:

Dean Goldsmith

Director

Blackett Maguire + Goldsmith



A. INTRODUCTION

A.1 BACKGROUND / PROPOSAL

Blackett Maguire + Goldsmith Pty Ltd (BM+G) have been commissioned by Goodman Property Services, to undertake a preliminary review of the proposed development, against the deemed-to-satisfy (DTS) provisions of the Building Code of Australia 2016 (BCA) pursuant to the provisions of clause 145 of the *Environmental Planning & Assessment Regulation 2000* and clause 18 of the *Building Professionals Regulation 2007*.

The proposed development comprises of the construction of three industrial precincts (known as Precincts 1, 3 & 4), which forms part of the Oakdale South Industrial Estate Masterplan. The two proposed precincts contain a total of eight (8) new warehouse buildings, each with ancillary offices, carparking facilities and loading areas. Precinct 1 consists of five (5) warehouse buildings known as Sites 1A to 1D (with Site 1A containing two separate buildings and the other three sites including a single building each). The remaining three (3) buildings in Precincts 3 & 4 are subject to separate development applications and as such will not be assessed as part of this report – see Estate Plan below.

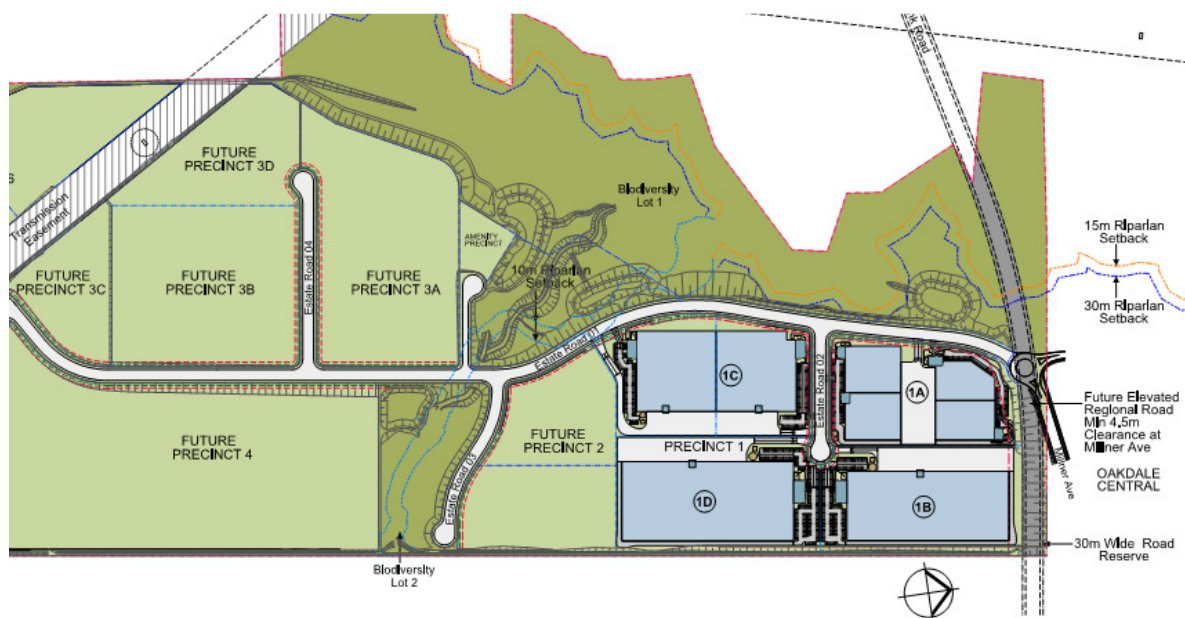

Source: SBA Architects Drawing No. OAK SOU MP 03K

A.2 AIM

The aim of this report is to:

- Undertake an assessment of the proposed warehouse facility against the Deemed-to-Satisfy (DtS) Provisions of the BCA 2016.
- Identify any BCA compliance issues that require resolution/attention for the proposed development at the CC Application stage.

A.3 PROJECT TEAM

The following BM+G Team Members have contributed to this Report:

- Dean Goldsmith (Director)
- Tony Heaslip (Peer Review Building Surveyor)

A.4 DOCUMENTATION

The following documentation has been reviewed, referenced and/or relied upon in the preparation of this report:

- BCA 2016



- Guide to the BCA 2016.
- Architectural plans prepared by SBA Architects Pty Ltd, as listed below:

Drawing No.	Rev.	Date	Drawing No.	Rev.	Date
MP01	M	01/07/2016	MP02	W	07/07/2016
MP03	K	01/07/2016	MP04	L	06/06/2016
MP05	A	01/06/2016	MP06	A	02/06/2016
MP07	J	01/07/2016	MP08	J	06/06/2016
MP09	J	07/07/2016	MP10	G	06/06/2016
MP11	H	06/06/2016	MP12	H	06/06/2016
MP13	B	06/06/2016	MP14	C	07/07/2016
MP15	G	01/07/2016	MP16	F	06/06/2016
MP17	E	06/06/2016			

A.5 REGULATORY FRAMEWORK

Pursuant to clause 145 of the Environmental Planning and Assessment (EPA) Regulation 2000 all new building work must comply with the current BCA however the existing features of an existing building need not comply with the BCA unless upgrade is required by other clauses of the legislation.

A.6 LIMITATIONS & EXCLUSIONS

The limitations and exclusions of this report are as follows:

- The following assessment is based upon a review of the architectural documentation.
- No assessment has been undertaken with respect to the Disability Discrimination Act (DDA) 1992. The building owner should be satisfied that their obligations under the DDA have been addressed. In this regard however, the provisions of the DDA Access to Premises – Buildings Standards have been considered as they are generally consistent with the accessibility provisions of the BCA.
- The Report does not address matters in relation to the following:
 - i. Local Government Act and Regulations.
 - ii. NSW Public Health Act 1991 and Regulations.
 - iii. Occupational Health and Safety (OH&S) Act and Regulations.
 - iv. Work Cover Authority requirements.
 - v. Water, drainage, gas, telecommunications and electricity supply authority requirements.
 - vi. DDA 1992.
- BM+G Pty Ltd do not guarantee acceptance of this report by Local Council, FRNSW or other approval authorities.
- No part of this document may be reproduced in any form or by any means without written permission from BM+G Pty Ltd. This report is based solely on client instructions, and therefore, should not be used by any third party without prior knowledge of such instructions.

A.7 TERMINOLOGY

Alternative Solution

A Building Solution which complies with the Performance Requirements other than by reason of satisfying the DtS Provisions.



Building Code of Australia (BCA)

Document published on behalf of the Australian Building Codes Board. The BCA is a uniform set of technical provisions for the design and construction of buildings and other structures throughout Australia and is adopted in New South Wales (NSW) under the provisions of the EPA Act and Regulation. Building regulatory legislation stipulates that compliance with the BCA Performance Requirements must be attained and hence this reveals BCA's performance based format.

Construction Certificate

Building Approval issued by the Certifying Authority pursuant to Part 4A of the EP&A Act 1979.

Construction Type

The construction type is a measure of a buildings ability to resist a fire. The minimum type of fire-resisting construction of a building must be that specified in Table C1.1 and Specification C1.1, except as allowed for—

- (i) certain Class 2, 3 or 9c buildings in C1.5; and
- (ii) a Class 4 part of a building located on the top storey in C1.3(b); and
- (iii) open spectator stands and indoor sports stadiums in C1.7.

Note: Type A construction is the most fire-resistant and Type C the least fire-resistant of the types of construction.

Climatic Zone

Is an area defined in BCA Figure A1.1 and in Table A1.1 for specific locations, having energy efficiency provisions based on a range of similar climatic characteristics.

Deemed to Satisfy Provisions (DtS)

Provisions which are deemed to satisfy the Performance Requirements.

Effective Height

The vertical distance between the floor of the lowest storey included in the calculation of rise in storeys and the floor of the topmost storey (excluding the topmost storey if it contains only heating, ventilating, lift or other equipment, water tanks or similar service units).

Fire Resistance Level (FRL)

The grading periods in minutes for the following criteria-

- (a) structural adequacy; and
- (b) integrity; and
- (c) insulation,

and expressed in that order.

Fire Source Feature (FSF)

The far boundary of a road which adjoins the allotment; or a side or rear boundary of the allotment; or an external wall of another building on the allotment which is not a Class 10 building.

National Construction Code Series (NCC)

The NCC was introduced 01 May 2011 by the Council of Australian Governments. The BCA Volume One (Class 2 to 9 Buildings) is now referenced as the National Construction Code Series Volume One — BCA.



Occupation Certificate

Building Occupation Approval issued by the Principal Certifying Authority pursuant to Part 4A of the EPA Act 1979.

Open Space

A space on the allotment, or a roof or other part of the building suitably protected from fire, open to the sky and connected directly with a public road.

Performance Requirements of the BCA

A Building Solution will comply with the BCA if it satisfies the Performance Requirements. A Performance requirement states the level of performance that a Building Solution must meet.

Compliance with the Performance Requirements can only be achieved by-

- (a) complying with the DtS Provisions; or
- (b) formulating an Alternative Solution which-
 - (i) complies with the Performance Requirements; or
 - (ii) is shown to be at least equivalent to the DtS Provisions; or
- (c) a combination of (a) and (b).

Sole Occupancy Unit (SOU)

A room or other part of a building for occupation by one or joint owner, lessee, tenant, or other occupier to the exclusion of any other owner, lessee, tenant, or other occupier and includes a dwelling.

B. BUILDING CHARACTERISTICS

B.1 BUILDING CLASSIFICATION

The following table presents a summary of relevant building classification items of the proposed warehouse development (x9 buildings):

▪ BCA Class:	All Buildings – Class 5 (Office) & Class 7b (Warehouse) Pump Rooms & Tanks – Class 10b
▪ Rise in Storeys:	All Buildings - Two (2)
▪ Effective Height:	All Buildings - Less than 12m
▪ Type of Construction:	All Buildings - Type C Construction (Large Isolated Building)
▪ Climate Zone:	Zone 6
▪ Maximum Floor Area:	Site 1A Warehouses 1/2 & 3/4; - Large Isolated Building – <18,000m ² ; Site 1B, Site 1C, Site 1D - Large Isolated Building - >18,000m ²
▪ Maximum Volume:	Site 1A Warehouses 1/2 & 3/4 - Large Isolated Building – <108,000m ³ Site 1B, Site 1C, Site 1D - Large Isolated Building - >108,000m ³ (Note: Architect to confirm exact volume);



C. BCA ASSESSMENT

C.1 BCA DEEMED-TO-SATISFY COMPLIANCE ISSUES:

The following comments have been made in relation to the relevant BCA provisions relating to the compliance issues associated with the proposed industrial facility in Precinct 1 only .

SECTION B- STRUCTURE

1. Part B1 - Structural Provisions

Structural engineering details prepared by an appropriately qualified structural engineer to be provided to demonstrate compliance with Part B1. This will include the following Australian Standards (where relevant):

1. AS 1170.0 – 2002 General Principles
2. AS 1170.1 – 2002, including certification for balustrading (dead and live loads)
3. AS 1170.2 – 2011, Wind Actions
4. AS 1170.4 – 2007, Earthquake Actions in Australia
5. AS 3700 – 2011, Masonry Structures
6. AS 3600 – 2009, Concrete Structures
7. AS 4100 – 1998, Steel Structures
8. AS 4600 – 2005, Cold Formed Steel Structures.
9. AS 2159 – 2009, Piling – Design and Installation
10. AS 1720.1 – 2010, Design of Timber Structure
11. AS/NZS 1664.1 and 2 – 1997, Aluminium Structures
12. AS 2047 – 2014, Windows and External Glazed Doors in Buildings
13. AS 1288 – 2006, Glass in Buildings - Selection and Installation

Comments: Structural design and certification will be required at CC application stage for each building.

SECTION C – FIRE RESISTANCE

FIRE RESISTANCE AND STABILITY

2. Clause C1.1 – Type of Construction Required

The minimum type of fire-resisting construction of a building must be that specified in Table C1.1 and Specification C1.1 except as allowed for in this clause.

Comments: Type C Construction applies to each of the nine (9) buildings included in the proposed development – see notes under Spec. C1.1 below.

3. Clause C1.2 – Calculation of Rise in Storeys

The rise in storeys of a building is the sum of the greatest number of storeys at any part of the external walls of the building and any storeys within the roof space calculated in accordance with the requirements set out in this clause.

Comments: Rise of Two (2) Storeys applies to each the eight (8) buildings.

4. Clause C1.10 – Fire Hazard Properties

The fire hazard properties of the following linings, materials and assemblies in a Class 2 to 9 building must comply with **Specification C1.10** and the additional requirements of the **NSW Provisions** of the Code.

Note: See NSW C1.10(a) & (b).

Comments: Note: Design certification required at CC application stage.



COMPARTMENTATION AND SEPARATION

5. Clause C2.2 - General Floor Area and Volume Limitations

Sets out the parameters for the area and volume of Class 5, 6, 7, 8 & 9 buildings as required by sub-clauses (a), (b) & (c).

Note: Table C2.2 maximum size of Fire Compartments or Atriums.

Comments: The proposed Warehouse buildings are Class 5 & 7b – Large Isolated Buildings of Type C Construction and as such the provisions for maximum fire compartment size under Table C2.2 do not apply. Refer to comments under C2.3 & C2.4 below in relation to the Large Isolated Building provisions applicable to the proposed development.

6. Clause C2.3 - Large Isolated Buildings

A Large Isolated Building that contain Class 5, 6, 7, 8n or 9 parts, is required to be—

- (i) protected throughout with a sprinkler system complying with Specification E1.5; and
- (ii) provided with a perimeter vehicular access complying with C2.4(b).

Comments: The proposed warehouse buildings are required to be sprinkler protected throughout and provided with perimeter vehicular access in accordance with Clause C2.4 (see notes below) pursuant to their Large Isolated Building designation under this clause.

7. Clause C2.4 - Requirements for Open Spaces & Vehicular Access

An open space and vehicular access required by C2.3 must comply with the requirements of sub-clauses (a) & (b) of this Part as that they must be 6m wide within 18m of the building and of a suitable bearing capacity and unobstructed height to permit the operation and passage of F&RNSW vehicles.

Comments: The proposed warehouse buildings do not comply with the provisions of C2.4 and thus the following non-compliance issues are required to be addressed as an alternative solution by the Fire Safety Engineer to demonstrate compliance with Performance Requirement CP9 - refer to the dot points and the diagram below for details of the proposed non-compliance issues:

- Vehicular Access is provided around the four (4) sides of all of the Warehouses & however, it is greater than 18m from the external walls of all the building- refer to diagram below.

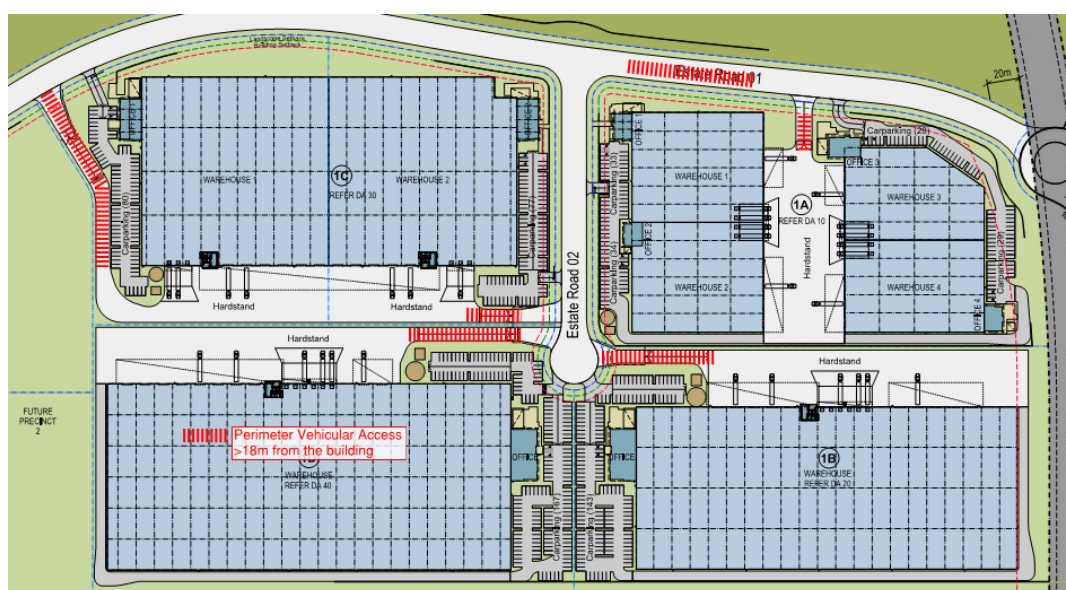

Figure 1 – Areas of Non-Compliant Perimeter Vehicular Access per BCA C2.4.



8. Clause C2.8 - Separation of Classifications in the Same Storey

If a building has parts of different classifications located alongside one another in the same storey, each element must have the required higher FRL for the classifications concerned.

Alternatively, the parts must be separated by a fire wall having the higher FRL for the classifications prescribed in Table 3 or 4 of BCA Specification C1.1 (for Type a or Type B Construction), or Table 5 for Type C Construction.

Comments: As the proposed buildings are of Type C Construction the same FRL requirements apply to both the Class 5 and Class 7b parts. Given the above, the provisions of C2.8(a) may be applied and in turn a fire wall between the Class 5 and Class 7b parts is not required.

9. Clause C2.12 - Separation of Equipment

Equipment as listed below must be separated from the remainder of the building with construction complying with (d), if that equipment comprises –

- (i) Lift motors and lift control panels; or
- (ii) Emergency generators used to sustain emergency equipment operating in the emergency mode; or
- (iii) Central smoke control plant; or
- (iv) Boilers; or
- (v) A battery or batteries installed in the building that have a voltage exceeding 24 volts and a capacity exceeding 10 ampere hours.

Note: Separating construction must have –

- (A) an FRL as required by Specification C1.1, but not less than 120/120/120; and
- (B) any doorway protected with a self-closing fire door having an FRL of not less than -/120/30.

Comments: Where appropriate, details demonstrating compliance are to be included in the CC Application plans for the new warehouse facility.

10. Clause C2.13 - Electricity Supply System

(a) An electricity substation, main switchboard which sustains emergency equipment operating in the emergency mode, located within a building must –

- (i) Be separated from any other part of the building by construction having an FRL of not less than 120/120/120; and
- (ii) Having any doorway in that construction protected with a self-closing fire door having an FRL of not less than -/120/30
- (i) Be separated from any other part of the building by construction having an FRL of not less than -/120/30.
- (ii) Have any doorway in that construction protected with a self-closing fire door having an FRL of not less than -/120/30.

(b) Electrical conductors located within a building that supply

Note: Where emergency equipment is required in a building, all switchboards in the electrical installation, which sustain the electricity supply to the emergency equipment switchgear is separated from the non-emergency equipment switchgear by metal partitions designed to minimise the spread of fault from the non-emergency equipment switchgear.

Comments: Where appropriate, details demonstrating compliance are to be included in the CC Application plans for the new warehouse facility.



PROTECTION OF OPENINGS

11. Clause C3.15 – Openings for Services Installations

All opening for services installations in building elements required to be fire-resisting with respect to integrity and insulation must be protected in accordance with the provisions of Spec. C3.15.

Comments: Note.

SPECIFICATIONS

12. Specification C1.1 – Fire Resisting Construction

The new building works are required to comply with the requirements detailed under Table 5 of Specification C1.1 for Type C Construction. In this regard the proposed building elements are required to comply.

Comments: Due to the configuration and position of the buildings on site there are no building elements required to be fire rated under the provisions of Table 5 of Spec C1.1.

13. Specification C1.10 – Fire Hazard Properties.

This Specification sets out requirements in relation to the fire hazard properties of linings, materials and assemblies in Class 2 to 9 buildings as set out in the Tables.

Comments: Refer to comments under Clause C1.10 above – certification will be required at both CC and OC Application stages.

14. Specification C1.11 – Performance of External Walls in Fire

This specification contains measures to minimise in the event of fire the likelihood of external walls collapsing outwards as complete panels and the likelihood of panels separating from supporting members.

Comments: Structural Design certification and details demonstrating compliance are required to be provided at CC Application stage.

SECTION D – ACCESS & EGRESS

PROVISION FOR ESCAPE.

15. Clause D1.3 – When Fire Isolated Stairways & Ramps are Required

This clause specifies the requirements for when fire isolated stairs or ramps are required in buildings based upon the number of storeys that they interconnect and the classification of the building.

Comments: The exit stairs serving Level 1 of each of the offices in each building, connect two storeys in a sprinkler protected building and as such are not required to be fire isolated in accordance with D1.3(b).

16. Clause D1.4 – Exit Travel Distances

This clause specifies the permitted travel distances allowable from Class 2 to Class 9 buildings. Sub-clauses (a) to (f) specify the maximum distances to be taken into account for the various uses in each Class of building.

Comments: The exit travel distances in the building are considered to be non-compliant with the requirements of Clause D1.4, in the following areas:

- + Site 1A Warehouse 1/2 - maximum exit travel distances of 60m.
- + Site 1A Warehouse 3/4 - maximum exit travel distances of 60m.
- + Site 1B - maximum exit travel distances of 70m.
- + Site 1C - maximum exit travel distances of 95m.
- + Site 1D - maximum exit travel distances of 85m.



The above non-compliance issues are required to be addressed as an alternative solution by the Fire Safety Engineer to demonstrate compliance with Performance Requirements DP4 & EP2.2.

17. Clause D1.5 – Distances Between Alternative Exits

Exits required as alternative exits must be –

- (a) not less than 9m apart; and
- (b) not more than – 60m apart.
- (c) Located so that the alternative paths of travel do not converge such that they become less than 6m apart.

Comments: The distances between alternative exits in the warehouse portions of each building are considered non-compliant with the provisions of D1.5, in the following areas:

- + Site 1A Warehouse 1/2 - maximum distances between alternative exits of 110m.
- + Site 1A Warehouse 3/4 - maximum distances between alternative exits of 110m.
- + Site 1B - maximum distances between alternative exits of 130m.
- + Site 1C - maximum distances between alternative exits of 180m.
- + Site 1D - maximum distances between alternative exits of 160m.

The above non-compliance issues are required to be addressed as an alternative solution by the Fire Safety Engineer to demonstrate compliance with Performance Requirements DP4 & EP2.2.

18. Clause D1.6 – Dimensions of Exits

This clause details the minimum dimensions such as height and width of paths of travel from Class 2 to 9 buildings. It also specifies the minimum dimensions of doorways from the various compartments and the width of exit doors from buildings depending on the uses and functions carried out within them.

Comments: Population numbers for the proposed warehouse buildings are required to be provided by Goodman at the CC Application to facilitate an assessment of the provisions of D1.6. In this regard, however, it is considered that compliance is readily achievable.

In addition to the above, it is to be noted that all exit paths are required to have a minimum clear height of 2m and 1980mm through doorway openings per D1.6(a).

19. Clause D1.9 – Travel by Non-fire-isolated Stairways or Ramps

Sub-clauses (a) to (f) set out the prescribed travel distances to be provided in required exits of Class 2 to 9 buildings and Class 4 parts of buildings. The sub-clauses set out the maximum distances to be taken into account for the various uses in each Class of building.

Comments: The proposed exit stairs within the offices of each building are capable of achieving compliance with D1.9 - further details are to be provided at CC application stage.

20. Clause D1.10 – Discharge From Exits

Requires that an exit must not be blocked at the point of discharge. Barriers such as bollards must be installed to prevent vehicles from blocking the discharge from exits.

This clause also provides the methods of construction, location and separation, at exit discharge points for all building Classes.

Comments: All discharge points from the building are required to be protected in accordance with the requirements of this clause.

21. Clause D1.13 – Number of Persons Accommodated

Clause D1.13 and Table D1.13 are used to calculate the anticipated number of people in particular types of buildings so that minimum exit widths and the required number of



sanitary and other facilities can be calculated. This clause and table are not to be used for non-BCA purposes.

Comments: In accordance with the comments under D1.6 above population numbers for the proposed warehouse buildings are to be provided by Goodman at CC Application stage.

CONSTRUCTION OF EXITS

22. Clause D2.3 - Non-fire-isolated Stairways & Ramps

This clause requires that required non-fire-isolated stairways and ramps must be either constructed in accordance with D2.2 or the alternative options set out in D2.3 (a) to (c).

Comments: The requirements of D2.3 apply to the proposed stairs serving each of the office upper levels in the two (2) Warehouse Buildings. Details are to be provided of the stair design at CC application stage.

23. Clause D2.7 - Installations in Exits & Paths of Travel

This clause restricts the installation of certain services in fire-isolated exits, non-fire-isolated exits and certain paths of travel to exits. Sub-clauses (a) to (e) prescribes which services **shall not be installed** as well as the circumstances in which certain services **may be installed** in fire-isolated and non-fire-isolated exits.

Comments: This requirement applies to all cupboards containing electrical distribution boards or comms. equipment that are located in a path of travel to an exit. In this regard such cupboards are to be enclosed in non-combustible materials and are to be suitably sealed against the spread of smoke.

24. Clause D2.8 - Enclosure of Space Under Stairs & Ramps

A space below a required fire-isolated stairway or ramp in a fire-isolated shaft must not be enclosed to form a cupboard or other enclosed space. If the required stairway or ramp is non-fire-isolated, (including an external stairway) any cupboard underneath must have an FRL of 60/60/60, with a self-closing -60/30 door.

Comments: Applies to the proposed egress stairs serving the upper office levels and any proposed storage enclosures below them on the ground floor level in each of the office areas in the Warehouse Buildings.

25. Clause D2.13 - Goings & Risers

This clause sets out the detailed requirements for the construction and geometry of the goings and risers in required stairways. These details are set out in sub-clauses (a) to (c) and Table D2.13 Riser and Going Dimensions.

Note: NSW D2.13(a)(ix)(x)(xi).

Comments: Applies to the proposed stairs serving the office upper levels and the external stairs. Details demonstrating compliance are to be submitted with the CC Application drawings.

26. Clause D2.14 - Landings

The dimensions and gradients of landings in stairways are set out in this clause; the configuration will depend on the proposed use of a building. Sub-clause (b) details the layout for a Class 9a building to allow for the movement of a stretcher.

Comments: Applies to the proposed stairs serving the office upper level. Details demonstrating compliance are to be submitted with the CC Application drawings.

27. Clause D2.15 - Thresholds

The threshold of a doorway must not incorporate a step or ramp at any point closer to the doorway than the width of the door leaf unless –

- (i) the doorway opens to a road or open space, external stair landing or external balcony; and
- (ii) the door sill is not more than 190mm above the finished surface of the ground, balcony, or the like, to which the doorway opens.



Comments: Architect to note, details demonstrating compliance will be required to be included in the CC plans.

28. Clause D2.16 – Balustrades or Other Barriers

This clause details where balustrades are required to be provided and sets out in specific detail the construction requirements in sub-clauses (a) to (i) and Tables D2.16(a), D2.16(b) & D2.16(c).

Comments: Applies to the proposed stairs and associated void serving the office upper levels, all stairs serving as external exits from the warehouse areas, and external rec. areas or accessway where the drop to the level below exceeds 1m. Details demonstrating compliance are to be submitted with the CC Application drawings. Note: The provisions of D2.16(g) and (h)(ii) apply to all external stairs and the stairs in the offices – ie. min. height of 1m & no gaps greater than 125mm.

29. Clause D2.17 – Handrails

This Clause sets out the requirements regarding the location, spacing and extent of handrails required to be installed in buildings.

Comments: Architect to note, details demonstrating compliance will be required to be included in the CC plans. Handrails serving all stairs and ramps both internally and externally to the building are required to comply with the accessibility requirements of Clause D3.3 and AS 1428.1-2009.

30. Clause D2.20 – Swinging Doors

A swinging door in a required exit or forming part of a required exit must be installed to the requirements of sub-clauses (a), (b) & (c). This clause only applies to swinging doors in doorways serving a required exit or forming part of a required exit. It does not apply to other doorways – see notes in the Guide to the BCA.

Comments: The proposed egress doors are required to swing in the direction of egress in accordance with D2.20(a).

31. Clause D2.21 – Operation of Latch

A door in a required exit or forming part of a required exit and in a path of travel to a required exit must be readily openable without a key from the side that faces a person seeking egress, by a single downward action or pushing action on a single device which is located between 900mm & 1.1m from the floor. This clause prohibits the use of devices such as deadlocks and knobs where knobs must be operated in a twisting motion in accordance with sub-clauses (a) & (b). D2.21 also sets out exceptions in relation to buildings where special security arrangements are required in relation to the uses carried out.

Comments: Architect to note, details demonstrating compliance will be required to be included in the CC plans.

ACCESS FOR PEOPLE WITH A DISABILITY

32. Clause D3.2 – Access to Buildings

This part requires accessways to be provided to accessible buildings from the main points of pedestrian entry at the allotment boundary and any accessible car parking space or accessible associated buildings connected by a pedestrian link.

Comments: Compliant Access is required throughout all areas in the proposed buildings in accordance with AS 1428.1-2009. Refer to D3.3 and D3.4 below.

33. Clause D3.3 – Parts of the Building to be Accessible

This part specifies the requirements for accessways within buildings which must be accessible.

Note: If compliant access is not proposed to be provided to the Warehouse areas in each building, comment will be required from an Access Consultant as to whether a concession under D3.4 or an alternative solution can be considered.



Comments: The following provisions of Clause D3.3 and in turn AS 1428.1-2009 are applicable to the proposed buildings:

- a. Access into the principal entrance of the ground floor main lobby of each warehouse unit will be required to comply with AS1428.1-2009. This will necessitate 1:40 cross falls / landings at the accessible entrance.
- b. An accessible pathway is required to be provided from the Estate Roads adjoining the sites to the main entry of each warehouse. In addition, a compliant accessible path is required on the site between the main entrances of each of the buildings/tenancies to the other buildings within the Precinct. Details demonstrating compliance will be required at CC Application and particular attention is drawn to the need to provide dedicated pathways that are independent of the truck accessway around the site.
- c. A passenger lift is required in the Office areas of each building where the floor area exceeds 200m² and is to comply with BCA Clause E3.6 in order to access the upper storey. The lift floor dimensions must be a minimum of 1.1m wide x 1.4m deep for all lifts that travel less than 12m. Design details are also required on the Construction Certificate plans.
- d. Turning Spaces & Passing Spaces for people in wheelchairs are required to be provided in common corridors in accordance with Section 6 of AS 1428.1-2009. Note: This applies to each end of the lobby on each level of the building which is currently non-compliant.
- e. All new internal surfaces are required to have a slip-resistant surface and the texture of the surface shall be traversable by persons with a disability pursuant to Section 7.1 of AS1428.1-2009:
 - i. Internal finishes and coverings (i.e. vinyl and tiles) are required to achieve a slip resistance classification under wet & dry conditions to comply with AS/NZS 4586-2004 'Slip Resistance Classification of New Pedestrian Surface Materials'.
 - ii. All finished vertically abutting floor surfaces are to be trip free, the following details demonstrate the tolerance level for floor finishes:



Figure 6: Trip Free Surfaces

Source - Section 7.2 of AS1428.1-2009

- f. Each accessible stairway are required to be designed and constructed in accordance with the requirements specified under Section 10 and 11 of AS1428.1-2009 that includes handrails on either side:

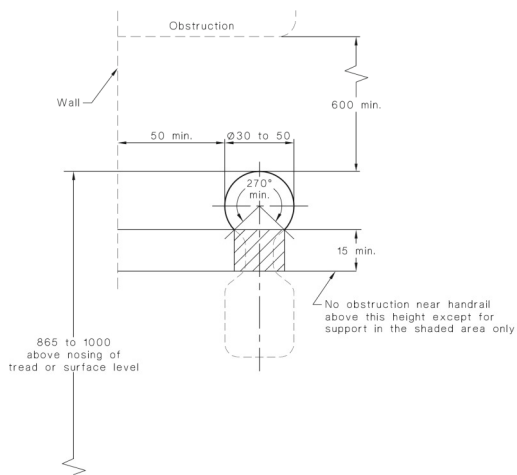

Figure 7: Handrail Details

Source – Section 10.3 and 12 of AS1428.1-2009

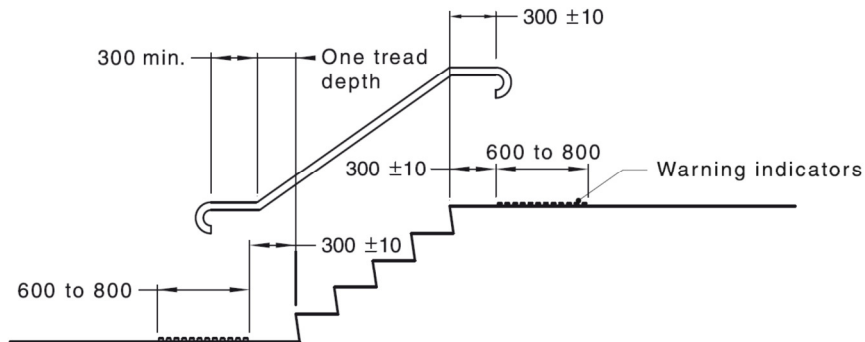

Figure 8: Handrail Details

Source – Section 10.3 of AS1428.1-2009

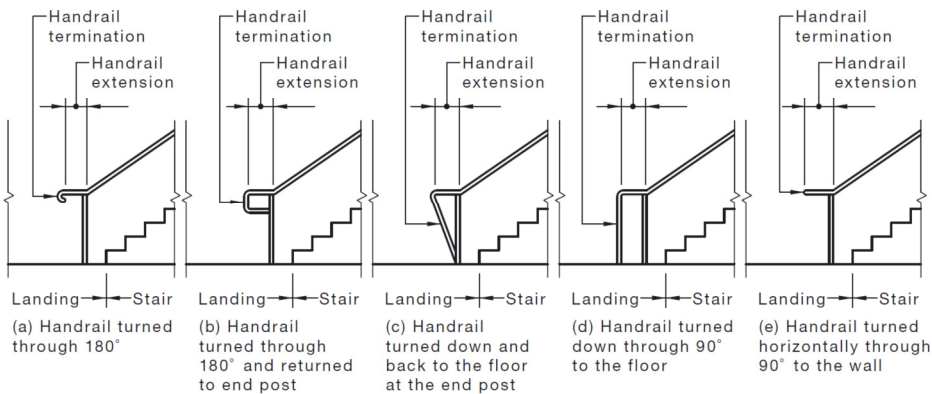

Figure 9: Handrail Details

Source – Section 11.1 and 12 of AS1428.1-2009

- f. Contrast nosings are required to the new accessible stairways in accordance with AS1428.1-2009 below:

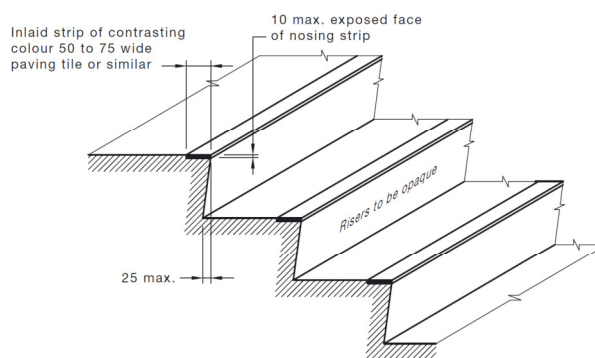

Figure 10: Nosing Details

Source – Section 10.8.1 of AS1428.1-2009

Note: Internal stairways to comply with Section 11 of AS1428.1-2009 and contrast nosings are also to be provided to fire stairs pursuant to Clause 11.1 (f) and (g).

- g. BCA Clause D3.3(g) requires that any proposed carpets within the building are to have a pile height or pile thickness not exceeding 11mm and the carpet backing thickness shall not exceed 4mm (total thickness shall not exceed 15mm).
- h. A luminance contrast colour of 30% is to be provided to all new doorways; including door frames (to clearly identify the difference between the door and the adjoining wall/door frame).
- i. Accessible doorways in common areas are to achieve a minimum unobstructed clear width of 850mm (clear opening width does not include the door leaf thickness) and where there are double doors proposed, at least one leaf is to achieve this minimum clearance.
- j. The circulation space around all accessible swinging doors is required to comply with Clause 13.3 and Figure 31 of AS 1428.1-2009. Circulation space requirements are to be detailed on the CC drawings – refer to Section 13 of AS1428.1-2009. Generally all doors require a clear space of 530mm at the latch side of the door and 110mm at the hinge side of the door to achieve compliance on a 'front on approach' accordingly.
- k. All door handles and related hardware to swinging doorways are required to be a type 'D' handle which allows the door to be unlocked and opened with one hand in accordance with Clause 13.5.2.
- l. The required accessible car spaces are to comply with AS 2890.6 – 2009.

Details demonstrating compliance and/or design certification are to be provided at the CC Application stage.

34. Clause D3.4 - Exemptions

This part provides exemptions to the Deemed-to-Satisfy provisions for access by people with a disability. This part provides details on buildings or parts of buildings not required to be accessible under the BCA where providing access would be inappropriate because of the nature of the area or the tasks undertaken.

Comments: It is recommended that advice be obtained from the Access Consultant at the CC Application stage in this regard, however, consideration to an exemption for the warehouse areas (on health & safety risk basis) may be appropriate on this project.

35. Clause D3.5 - Accessible Carparking

This part provides details of the number of accessible carparking spaces required in a carpark depending on the classification of the building.

Comments: In the case of Class 5 & 7b buildings 1 compliant accessible space is required for every 100 parking spaces or part thereof.. In this regard we note that two (2)



accessible parking spaces are proposed on the site at each proposed warehouse tenancy, which in total achieves compliance with the requirements of D3.5.

36. Clause D3.6 - Signage

This section provides requirements for signage in buildings required to be accessible By Part D3.

Comments: Signage will be required to identify exits, accessible facilities, an ambulant accessible facility and the paths to accessible pedestrian entries (where required).

37. Clause D3.8 - Tactile Indicators

This clause provides for the installation of tactile indicators in buildings required to be accessible and must be provided to warn people who are blind or have a vision impairment that they are approaching a stairway, escalator, passenger conveyor, ramp, overhead obstruction or an accessway meeting a vehicular way, except for areas exempted by D3.4.

Comments: Compliant tactile indicators are required in all areas of the buildings to all ramps, stairs, paths approaching a driveway and any overhead obstructions less than 2m in height.

38. Clause D3.11 - Ramps

Ramps may be used as part of an accessway where there is a change of level and must comply with the requirements set out in AS1428.1.

Comments: Architect to note, details demonstrating compliance will be required to be included in the CC plans.

SECTION E - SERVICES AND EQUIPMENT

FIRE FIGHTING EQUIPEMENT

39. Clause E1.3 -.Fire hydrants

E1.3(a) - A fire hydrant system must be provided to serve a building having a total floor area greater than 500m² and where a fire brigade is available to attend a building fire.

E1.3(b) - Requires that the fire hydrant system must be installed in accordance with the provisions of AS2419.1 and also details where internal hydrants must be located.

Comments: The proposed Warehouse buildings are required to be served by a compliant hydrant system incorporating a ring main. Details demonstrating compliance with the provisions of AS 2419.1 are required to be provided at CC Application stage. Note: The location of the hydrant booster at each site adjoining the Estate Roads will be required to be within sight of the main entries of each building.

40. Clause E1.4 - Fire hose reels

A fire hose reel system must be provided to serve a building where one or more internal fire hydrants are installed or in a building with a floor area greater than 500m².

This clause requires that the fire hose reel system must be installed in accordance with AS 2441 and sets out the detail for location and uses of fire hose reels.

Comments: The proposed buildings are required to be served by a compliant fire hose reel system. Details demonstrating compliance are to be provided at the CC application stage.

41. Clause E1.5 - Sprinklers

A sprinkler system must be installed in a building or part of a building when required by Table E1.5 and comply with Specification E1.5. Table E1.5 sets out which types of building occupancies and Classes which are required to have sprinkler systems installed in them.

Specification E1.5 sets out requirements for the design and installation of sprinkler systems.



Comments: The proposed Large Isolated Buildings (x5 – Precinct 1) are required to be sprinkler protected throughout in order to address the requirements of Clause C2.3 and Table E1.5. Details demonstrating compliance are to be provided at the CC application stage.

42. Clause E1.6 – Portable fire extinguishers

Portable fire extinguishers must be provided as listed in Table E1.6 and must be selected, located and distributed in accordance with Sections 1, 2, 3 and 4 of AS 2444.

Comments: Fire extinguishers will be required to be installed in the proposed building in accordance with Table E1.6.

43. Clause E1.8 – Fire Control Centres

A fire control centre facility in accordance with Specification E1.8 must be provided for a building having an effective height of more than 25m and in a Class 6, 7, 8 or 9 building with a total floor area of more than 18,000m².

Specification E1.8 describes the construction and content of required fire control centres or rooms.

Comments: The buildings located on Sites 1B, 1C, & 1D exceed 18,000m² and as such are required to be provided with a Fire Control Centre that complies with Clauses 2-5 of BCA Spec. E1.8. Details demonstrating compliance are to be included on the CC Application plans.

SMOKE HAZARD MANAGEMENT

44. Clause E2.2 – General Requirements

Class 2 to 9 buildings must comply with the provisions of this Clause to remove smoke during a fire, to control the operation of air handling systems and to prevent the spread of smoke between compartments.

Buildings must comply with the provisions of **Table E2.2a**, as applicable to Class 2 to 9 buildings. It deals with the design and construction of air handling systems that are part of a smoke hazard management system and air handling system that are not part of a smoke hazard management system.

The details relating to the installation and operation of the systems are set out in **Specifications E2.2a, E2.2b** and **E2.2c**.

Comments: As the floor area and volume of Site 1A Warehouses 1/2 & 3/4 are less than 18,000m² and 108,000m³ respectively, smoke exhaust or smoke and heats are not required in these building.

As the volume of Site 1B, Site 1C, & Site 1D, are greater than 108,000m³ respectively (*subject to confirmation by the Architect*), smoke exhaust or smoke and heats are required to be provided within each of these buildings. In this regard, consideration may be given to an alternative solution to the required smoke hazard management requirements and in turn any such alternative solution will need to be prepared by the fire engineer and will need to demonstrate compliance with Performance Requirement EP2.2.

PART E3 LIFT INSTALLATIONS

45. Clause E3.3 – Warning Against use of Lifts in Fire

Warning signs required be provided must be displayed where they can be readily seen and must comply with the details and dimensions of **Figure 3.3**.

Comments: Lift Contractor to note.

46. Clause E3.5 – Landings

E3.5(a) The provisions of clause 12.2 – “Access” of AS 1735.2 do not apply.

E3.5(b) The provisions of Clause A3.2 – “Access to landings” of Appendix A of AS 1735.1 do not apply.



E3.5(c) Access and egress to and from lift well landings must comply with the Deemed-to-Satisfy Provisions of Part D.

Comments: Lift Contractor to Note.

47. Clause E3.6 – Passenger Lifts

In an accessible building, every passenger lift must be one of the types identified in **Table E3.6a**, have accessible features in accordance with **Table E3.6b** and not rely on a constant pressure device for its operation if the lift car is fully enclosed.

Comments: Lift Contractor to note.

EMERGENCY LIGHTING, EXIT SIGNS AND WARNING SYSTEMS

48. Clause E4.2 – Emergency Lighting Requirements

This clause details when emergency lighting must be installed in Class 2 to 9 buildings. The requirements for buildings and parts of buildings are detailed in sub-clauses (a) to (i) and each sub-clause must be considered as more than one may apply to any single building

Comments: Emergency Lighting is required throughout the buildings in accordance with E4.2, E4.4 and AS/NZS 2293.1-2005.

49. Clause E4.4 – Design & Operation of Emergency Lighting

Every required emergency lighting system must comply with AS2293.1.

Comments: Electrical Consultant to note.

50. Clause E4.5 – Exit Signs

An exit sign must be clearly visible to persons approaching the exit and must be installed on, above or adjacent to each door providing egress from a building. Sub-clauses (a) to (d) set out the situations where exit signs are required to be installed.

Comments: Electrical Consultant to note, details demonstrating compliance will be required to be included in the CC plans.

51. Clause E4.6 – Direction Signs

If an exit is not readily apparent to persons occupying or visiting the building then exit signs must be installed in appropriate positions in corridors, hallways, lobbies, and the like, indicating the direction to a required exit.

Note: NSW E4.6.

Comments: Electrical Consultant to note, details demonstrating compliance will be required to be included in the CC plans.

52. Clause E4.8 – Design & Operation of Exit Signs

Every required exit sign must comply with AS/NZS 2293.1 and be clearly visible at all times when the building is occupied by any person having the legal right of entry into the building.

Comments: Electrical Consultant to note, details demonstrating compliance will be required to be included in the CC plans.

SECTION F – HEALTH & AMENITY

DAMP AND WEATHERPROOFING.

53. Clause F1.1 – Stormwater drainage

Stormwater drainage must comply with AS/NZ 3500.3.

Comments: Details of stormwater disposal, from a suitably qualified consultant are required to be submitted with documentation for the CC.



54. Clause F1.5 - Roof Coverings

This clause details the materials and appropriate standards, with which roofs must be covered with. The roofing requirements are set out in sub-clauses (a), (b) (c), (d), (e) & (f) which set out the types of materials that may be used and the adopted Australian Standards that apply to their quality and installation.

Comments: Note.

55. Clause F1.6 - Sarking

Sarking-type materials used for weatherproofing of roofs must comply with AS/NZS 4200 parts 1 and 2.

Comments: Note.

56. Clause F1.7 - Waterproofing of Wet Areas

This clause requires that wet areas in Class 2 to 9 buildings must be waterproofed. It prescribes the standards to which the work must be carried out in sub-clauses (a) to (e) with emphasis in sub-clauses (c), (d) & (e) on the construction of rooms containing urinals and their installation.

Note: Figures F1.7(1) & F1.7(2) of the Guide to the BCA contain diagrams indicating the areas of walls and floors to be protected around baths, washbasins and showers.

Comments: Note.

SANITARY AND OTHER FACILITIES

57. Clause F2.3 - Facilities in Class 3 to 9 Buildings

This clause provides the requirements for sanitary facilities to be installed in Class 3, 5, 6, 7, 8 and 9 buildings in accordance with **Table F2.3**. The requirements and variations are set out in sub-clauses (a) to (h).

Comments: As indicated above proposed population numbers are to be provided by Goodman for each unit to assess if the proposed toilet facilities within the buildings are adequate to achieve compliance with Table F2.3. Details are to be provided at CC Application stage, however, compliance is readily achievable based on the current sanitary facilities numbers shown on the DA plans.

58. Clause F2.4 - Accessible Sanitary Facilities

Accessible unisex sanitary compartments must be provided, in accordance with **Table F2.4(a)** and unisex showers must be provided in accordance with **Table F2.4(b)**, in buildings or parts that are required to be accessible. The details for the provision of disable facilities and the standard, AS 1428.1, are set out in sub-clauses (a) to (i).

Comments: The proposed accessible toilet facilities and ambulant sanitary facilities in each tenancy are required to achieve compliance with the provisions of Table F2.4. Details demonstrating that the design of each facility complies with AS 1428.1 are to be provided at the CC application stage, however, compliance is readily achievable.

59. Clause F2.5 - Construction of Sanitary Compartments

- (a) Other than in an early childhood centre sanitary compartments must have doors and partitions that separate adjacent compartments and extend –
 - (i) from floor level to the ceiling in the case of a unisex facility; or
 - (ii) a height of not less than 1.5m above the floor if primary school children are the principal users; or
 - (iii) 1.8 above the floor in all other cases.
- (b) The door to a fully enclosed sanitary compartment must-
 - (i) open outwards; or
 - (ii) slide: or



(iii) be readily removable from the outside of the sanitary compartment, unless there is a clear space of at least 1.2m, measured in accordance with **Figure F2.5** between the closet pan within the sanitary compartment and the doorway.

Comments: Details demonstrating compliance are to be submitted with documentation for the CC Application.

LIGHT AND VENTILATION

60. Clause F4.4 – Artificial Lighting

Artificial lighting is required where it is necessary to minimise the hazard to occupants during an emergency evacuation. Sub-clauses (a), (b) & (c) sets out the places where artificial lighting is always required in all classes of buildings and the standard to which it must be installed.

Comments: Design certification to be submitted at CC Application Stage.

61. Clause F4.5 – Ventilation of Rooms

A habitable room, office, shop, factory, workroom, sanitary compartment, bathroom, shower room, laundry and any other room occupied by a person for any purpose must have natural ventilation complying with F4.6 or a mechanical or air-conditioning system complying with AS1668.2 and AS/NZS 3666.1.

Note: NSW F4.5(b) a mechanical ventilation or air-conditioning system complying with AS 1668.2 – the reference to AS/NZS 2666.1 is deleted from the BCA in NSW as the need to comply with this standard is regulated under the relevant section of the Public Health Act 1991.

Comments: Design certification to be submitted at CC Stage.

SECTION J – ENERGY EFFICIENCY

62. PART J1 – BUILDING FABRIC

The provision of insulation to the building envelope will be required in the proposed Building, in accordance with **Clauses J1.0 to J1.6**, and the **Tables therein**, including Thermal Construction General, Roof and Ceiling Construction, Roof-lights, Walls, and Floors.

Comments: This section applies to any air-conditioned spaces proposed within the warehouse buildings. Design details and/or certification of building envelope design will be required to be submitted with the application for a Construction Certificate.

63. PART J2 – GLAZING

Glazing within the external building envelope will be required to be assessed/designed to achieve compliance with **Clauses J2.0 to J2.5**, including the **Tables therein**, having regard to the maximum aggregate air-conditioning energy attributable to each façade of the proposed building.

Comments: This section applies to any air-conditioned spaces proposed within the warehouse buildings. A calculation demonstrating that the proposed design of the glazing in each building complies with the requirements of **Part J2** is required to be submitted with the application for a Construction Certificate.

64. PART J3 – BUILDING SEALING

The proposed building envelope will be required to be sealed to prevent air infiltration in accordance with the requirements of **Clauses J3.0 to J3.6**. is required to be provided.

Comments: This section applies to any air-conditioned spaces proposed within the warehouse buildings. Details or certification that the proposed design complies with the requirements of **Part J3** will need to be submitted with the application for a Construction Certificate.



65. PART J5 – AIR-CONDITIONING & VENTILATION SYSTEMS

Details and/or design certification which confirm that any proposed air-conditioning system or unit within the proposed building achieves compliance with the relevant requirements of **Part J5** will be required to be provided from the Mechanical Engineer.

Comments: Details or certification demonstrating compliance will need to be submitted with the application for a Construction Certificate.

66. PART J6 – ARTIFICIAL LIGHTING & POWER

Details and/or design certification which confirm that all artificial lighting, power control, and boiling/chilled water units within the proposed building achieves compliance with the relevant requirements of **Part J6** will be required to be provided from the Electrical Engineer.

Comments: Consultant certification required at CC Application Stage.

67. PART J7 – HOT WATER SUPPLY & SWIMMING POOL & SPA POOL PLANT

Details and/or design certification which confirm that any proposed hot water supply system within the proposed building achieves compliance with the relevant requirements of **Part J7** (Section 8 of AS 3500.4) will be required to be provided from the Hydraulic Engineer.

Comments: Consultant certification required at CC Application Stage.

68. SECTION J8 – ACCESS FOR MAINTENANCE & FACILITIES FOR MONITORING

Note: See NSW Subsection J8 for access to maintenance.

Access must be provided to all plant, equipment and components that require maintenance in accordance with Part I2, and suitable facilities for energy monitoring are required to be provided.

Comments: Consultant certification required at CC Application Stage.

C. CONCLUSION

This report contains an assessment of the referenced architectural documentation for the proposed warehouse/industrial development at Oakdale South Precinct 1, Horsley Park against the Deemed-to-Satisfy Provisions of the BCA 2015. Arising from the review, it is considered that the proposed development can readily achieve compliance with the relevant provisions of the BCA.