

391-423 Pacific Highway, Crows Nest

Construction Noise and Vibration Management Plan

Project ID	20241259.2
Document Title	Construction Noise and Vibration Management
Attention To	Deicorp Pty Ltd

Revision	Date	Document Reference	Prepared By	Checked By	Approved By
0	22/11/2024	20241259.2/1811A/R0/HD	HD		AW
1	10/06/2025	20241259.2/0406A/R1/PF	PF		PF
2	29/01/2026	20241259.2/2901A/R2/PF	PF		WY

TABLE OF CONTENTS

1	INTRODUCTION	5
2	DEVELOPMENT CONSENT CONDITIONS	6
3	REFERENCED DOCUMENTATION	8
3.1	BACKGROUND INFORMATION USED	8
3.2	GUIDELINES	8
4	SITE DESCRIPTION & PROPOSAL	9
4.1	PROPOSED WORKS	9
4.2	SENSITIVE RECEIVERS	10
5	HOURS OF WORK	12
6	EXISTING BACKGROUND NOISE LEVELS	13
7	NOISE AND VIBRATION SOURCES	14
8	CONSTRUCTION NOISE AND VIBRATION EMISSION MANAGEMENT LEVELS	15
8.1	NOISE MANAGEMENT LEVELS	15
8.1.1	2009 NSW Environmental Protection Authority (EPA) document – “Interim Construction Noise Guideline (ICNG) 2009”	15
8.1.2	Construction Noise Management Levels Summary	16
8.2	VIBRATION OBJECTIVES	17
8.2.1	Sydney Metro Underground Corridor Protection Technical Guidelines, (Ref: iCentral SM-20-00081444)	17
8.2.2	Development Near Rail Tunnels (Ref: T HR CI 12051 ST)	18
8.2.3	German Standard DIN 4150-3 (2016) - Ground Borne Vibrations and Damage Limits	18
8.2.4	Construction Noise Management Levels Summary	20
9	CONSTRUCTION NOISE AND VIBRATION ASSESSMENT	21
9.1	GENERAL	21
9.2	CONSTRUCTION NOISE ASSESSMENT	21
9.2.1	Noise Predictions	21
9.2.2	Predicted Noise Impacts	21
9.2.3	Discussion of Predicted Results – Noise	25
9.3	CONSTRUCTION VIBRATION	26
9.3.1	Vibration Sources	26
9.3.2	Assessment of Vibration	26
10	NOISE AND VIBRATION MANAGEMENT PLAN	27
11	NOISE AND VIBRATION MONITORING, REPORTING AND RESPONSE PROCEDURES	27
11.1	REPORTING REQUIREMENTS	28
11.2	RESPONSE PROCEDURES	28
12	NOISE AND VIBRATION MANAGEMENT AND CONTROL	29
12.1	GENERAL NOISE CONTROL METHODS	29
12.1.1	Selection of Alternate Appliance or Process	29
12.1.2	Acoustic Barriers	29
12.1.3	Silencing Devices	29
12.1.4	Treatment of Specific Equipment	29
12.1.5	Establishment of Site Practices	30
12.1.6	Vibration Management	30
12.2	SPECIFIC NOISE CONTROLS AND METHODOLOGY	31
12.3	RECOMMENDED NOISE AND VIBRATION MONITORING	32
12.4	SYDNEY METRO – SPECIFIC MONITORING AND RESPONSE PROCEDURES	34

12.4.1	Vibration Monitoring Locations – Sydney Metro Assets	34
12.5	MANAGEMENT FLOW CHART – NOISE AND VIBRATION	36
12.6	COMMUNITY LIAISON AND COMPLAINTS HANDLING	37
12.7	SUMMARY OF MITIGATION.....	38
13	CONCLUSION.....	40
APPENDIX A – CONSTRUCTION PLANT NOISE EMISSION LEVELS		41
	NOISE DESCRIPTORS	41
	CONSTRUCTION PLANT NOISE EMISSION LEVELS	42

1 INTRODUCTION

Acoustic Logic have been engaged to provide an updated project construction noise and vibration management sub-plan (“**CNVMSP**” or the “**Plan**”) in support of the modification application associated with construction works at 391-423 Pacific Highway, Crows Nest. The modification application seeks permission to extend the approved construction hours.

The Plan:

- Identifies sensitive receivers that are likely to be potentially impacted by the proposed works.
- Develops project specific noise and vibration management levels. These will be used to indicate whether additional impact mitigation, beyond normal “good practice”, is indicated.
- Identifies the major noise and vibration sources that will be present on the construction site, and additional construction-related traffic generated by the development.
- Predicts the likely noise and vibration levels during the phases of construction and assesses these against the established management levels. Where the predicted impacts exceed the management levels, the Plan identifies and assesses potential measures to minimise these impacts.
- Provides specific and general recommendations for the ongoing monitoring, assessment and management of noise and vibration emissions as the works progress in response to additional information and site conditions, and the updating of the Plan to reflect additional information obtained during the construction period.

The subject site and local context are indicated in Figure 1.

Where the term “construction” is used in this Plan, it includes excavation and any other site activity related to the construction of the development being assessed.

This Plan has been prepared for the sole purpose as stated above and should not be used or relied on for any other purpose.

2 DEVELOPMENT CONSENT CONDITIONS

The Plan addresses the following consent conditions in approval number SSD-66826207 repeated below.

MANAGEMENT PLANS

CONSTRUCTION ENVIRONMENTAL MANAGEMENT PLAN

- C1. Prior to the commencement of any work, the Applicant must prepare and submit to the Certifier a Construction Environmental Management Plan (**CEMP**) for the Development with measures to reduce environmental impacts and harm during construction of the Development, including, at a minimum, the following information:
- (a) details of:
 - (i) hours of construction;
 - (ii) 24 hour contact details of the site manager and complaint handling procedure;
 - (iii) construction program and construction methodology, including construction staging;
 - (iv) traffic management;
 - (v) noise and vibration management;
 - (vi) management of dust and odour;
 - (vii) stormwater control and discharge including ensuring that vehicles leaving the site do not transfer dirt to roadways;
 - (viii) prevention and management of contamination;
 - (ix) management of stockpiles of soil or other materials;
 - (x) waste management;
 - (xi) road reserve safety during construction;
 - (xii) external lighting in compliance with applicable Australian Standards; and
 - (xiii) site security, including fencing or hoarding.
 - (b) Construction Traffic and Pedestrian Management Sub-Plan in accordance with condition C2;
 - (c) Construction Noise and Vibration Management Sub-Plan in accordance with condition C3;
 - (d) Air Quality Management Sub-Plan in accordance with condition C4;
 - (e) Construction Waste Management Sub-Plan in accordance with condition C5;
 - (f) Construction Soil and Water Management Sub-Plan in accordance with condition C6;
 - (g) an unexpected finds protocol for remediation in accordance with condition C16;
 - (h) an unexpected finds protocol for Aboriginal and non-Aboriginal heritage and associated communications procedure, including but not limited to ensuring compliance with condition D30;
 - (i) waste classification (for materials to be removed) and validation (for materials to remain) to be undertaken to confirm the contamination status of relevant areas of the site.

CONSTRUCTION NOISE AND VIBRATION MANAGEMENT SUB-PLAN

- C3. Prior to the commencement of any work, the Applicant must submit to the Certifier a Construction Noise and Vibration Management Sub-Plan (**CNVMP**) for the Development with measures to reduce environmental impacts and harm during construction of the Development arising from construction noise and vibration, including, at a minimum, the following information:
- (a) identification of noise sources and Sensitive Receivers;
 - (b) quantification of the rating background noise level (**RBL**) for Sensitive Receivers;
 - (c) describe procedures for achieving the noise management levels in EPA's Interim Construction Noise Guideline (DECC, 2009) (**ICNG**) (as may be updated or replaced from time to time);
 - (d) prediction and assessment of potential noise, ground-borne noise (as relevant) and vibration levels from the proposed construction methods expected at Sensitive Receiver premises against the objectives identified in the ICNG;
 - (e) noise mitigation measures that can be implemented to reduce construction noise and vibration impacts, including:
 - (i) installation of acoustic barriers/enclosures;
 - (ii) alternative excavation methods;
 - (f) measures to identify non-conformances with the requirements of the CNVMP, and procedures to implement corrective and preventative action and to respond to complaints;
 - (g) procedures for notifying residents of construction activities that are likely to affect their noise and vibration amenity; and
 - (h) include a complaints management system that would be implemented for the duration of the development.

a

Table 1 – Consent Condition C3 Satisfaction Table

Condition	Condition requirements	Document reference
C3	The Construction Noise and Vibration Management Sub-Plan must address, but not be limited to, the following:	-
	(a) identification of noise sources and Sensitive Receivers	Section 4.2and Section 8.1
	(b) quantification of the rating background noise level (RBL) for Sensitive Receivers;	Section 6
	(b) describe procedures for achieving the noise management levels in EPA’s Interim Construction Noise Guideline (DECC, 2009);	Section 12
	(d) prediction and assessment of potential noise, ground-borne noise (as relevant) and vibration levels from the proposed construction methods expected at Sensitive Receiver premises against the objectives identified in the ICNG;	Section 9.2 and Section 9.3.2
	(e) noise mitigation measures that can be implemented to reduce construction noise and vibration impacts	Section 12
	(f) measures to identify non-conformances with the requirements of the CNVMP, and procedures to implement corrective and preventative action and to respond to complaints;	Section 12
	(g) procedures for notifying residents of construction activities that are likely to affect their noise and vibration amenity; and	Section 12
	(h) include a complaints management system that would be implemented for the duration of the development.	Section 12

3 REFERENCED DOCUMENTATION

3.1 BACKGROUND INFORMATION USED

The assessment is based on the following information:

- Development consent (approval number: SSD-66826207)
- Details regarding construction activities provided by Deicorp.
- Approved 'DA Acoustic Assessment' prepared by Acoustic Logic (ref 20230371.1/3107A/R4/PF, dated 31/07/2024).

3.2 GUIDELINES

The primary guideline that will be used to formulate the Plan is the NSW EPA – 'Interim Construction Noise Guideline' ("**ICNG**") July 2009.

The ICNG recognises that development occurs close to sensitive receivers and the nature of construction means that it is not possible to prevent noise impacts. The ICNG is focused *"on applying a range of work practices most suited to minimise construction noise impacts, rather than focusing only on achieving numeric noise levels. While some noise from construction sites is inevitable, the aim of the Guideline is to protect the majority of residences and other sensitive land uses from noise pollution most of the time."*

The ICNG requires the identification of activities likely to exceed the noise/vibration management levels, and the implementation of feasible and reasonable mitigation strategies to minimise emissions. Strategies include physical and management controls, liaising with the public and stakeholders, monitoring, etc. The ICNG recognises that each site will have a particular set of circumstances to be addressed, and that it is typically not possible to fully mitigate impacts. The guideline is intended as a pathway to determining a realistic compromise between construction sites and the surrounding receivers.

The following additional planning instruments and guidelines have also been used in the assessment:

- NSW Department of Environment and Conservation Assessing Vibration: A Technical Guideline" (Feb, 2006)
- NSW EPA – 'Noise Policy for Industry' ("**NPfi**") October 2017

4 SITE DESCRIPTION & PROPOSAL

The project site is located at 391-423 Pacific Highway, Crows Nest and consists of the demolition of existing structures, early works, site remediation and construction of a 28-storey mixed-use development with infill affordable housing comprising:

- Ground level retail
- Mezz level to podium hotel
- 289 residential units from level 2 to level 28
- Six levels of basement car parking
- Two-way vehicular access from Alexander Street; and
- Associated landscaping works, consolidation of existing

Site investigation indicates that the site is bounded by:

- Pacific Highway along the south western boundary
- Alexander Street along the eastern boundary, and
- Falcon Street along the northern boundary of the site.

The site is dominated by traffic noise from Pacific Highway with low to moderate volumes of traffic along Alexander Street and Falcon Street.

4.1 PROPOSED WORKS

AL note that the demolition work has been completed at this stage. Primary activities associated with the construction of the proposed development includes:

- Excavation: excavator and saw cutting during detail excavation works
- Piling – to be completed via bored piling
- Main Construction: This includes the erection of structure, façade, internal fitout and landscape works.

Site access will be via Alexander Street and Pacific Highway

4.2 SENSITIVE RECEIVERS

The nearest/potentially most impacted sensitive receivers surrounding the site representative of noise catchments have been identified and as summarised in the following table. An aerial photo of the site indicating nearby noise sensitive receivers and the catchment areas, and the ambient noise measurement locations is presented in Figure 1.

Table 2 – Sensitive Receivers

Receiver (Refer Figure 1)	Receiver Type	Comment
R1	Residential	Shop top Housing to the east of the site at 9 Alexander Street, Crows Nest
R2	Residential	Residential development to the far south across Pacific Hwy at 246-258 Pacific Hwy, Crows Nest
C1	Commercial	Multi-storey commercial buildings to the north of the site across Falcon Street at 8-10 Falcon Street, 1-3 Willoughby Road, Crows Nest
C2	Commercial	Multi-storey commercial buildings to the north east of the site across Falcon Street at 12-16 Falcon Street, Crows Nest
C3	Commercial	Multi-storey commercial building to the east of the site across Alexander Street, at 11-15 Alexander Street & 17-21 Falcon Street, Crows Nest
C4	Commercial	Multi-storey commercial building to the east of the site across Alexander Street, at 5-12 Alexander Street, Crows Nest
C5	Commercial	Multi-storey commercial building located to the southern corner of the site across Alexander Street, at 385-387 Alexander Street, Crows Nest
C6	Commercial	Multi-storey commercial buildings to the south west of the site across Pacific Hwy at 270-306 Pacific Hwy, Crows Nest



Figure 1 – Site & Surrounds including Surrounding Receivers

5 HOURS OF WORK

Currently conditioned construction hours (D3-D5) are repeated as below:

HOURS OF CONSTRUCTION

- D3. Construction, including the delivery of materials or machinery to and from the site, may only be carried out between the following hours:
- (a) between 7am and 6pm, Mondays to Fridays inclusive;
 - (b) between 8am and 1pm, Saturdays; and
 - (c) no work may be carried out on Sundays or public holidays.
- D4. Activities may be undertaken outside of these hours if required:
- (a) by the Police or a public authority for the delivery of vehicles, plant or materials to and from the site; or
 - (b) in an emergency to avoid the loss of life, damage to property or to prevent environmental harm.
- D5. Notification of activities undertaken in the circumstances in condition D4 must be given to sensitive receivers, as identified in the Construction Noise and Vibration Management Sub-Plan in condition C3 before undertaking the activities or as soon as is practical afterwards.
- D6. Rock breaking, rock hammering, sheet piling, pile driving and similar activities may only be carried out between the following hours:
- (a) **8am to 12pm, Monday to Friday;**
 - (b) **1pm to 5pm Monday to Friday; and**
 - (c) **8am to 12pm, Saturday.**

This modification application seeks the approval of extension of construction hours as follows:

- Saturday: 7am to 5pm
- Sunday: 8am and 5pm
- Public holidays: No work

For Sunday, works will be limited to internal fitout and finishing works and including:

- installation of ceilings
- painting
- rendering
- partition walls
- wall sheeting
- carpet laying
- joinery
- installation of internal services
- light fitting
- services installation

There is to be no truck deliveries, cranes operating or concrete pours on Sunday.

Following periods are considered an extension of hours compared to the currently conditioned construction hours (**condition D3**):

- Saturday: 7:00 am – 8:00 am and 1:00pm – 5:00pm, and
- Sunday: 8am – 5pm.

As such, predictions based on ICGN requirements for outside of standard hours noise management levels have been adopted to provide holistic noise modelling.

6 EXISTING BACKGROUND NOISE LEVELS

Rating background noise levels are adopted from the referenced acoustic assessment at DA stage.

The following table summarises the rating background noise levels determined for the day, evening and night periods as defined in the NSW EPA’s NPfI.

Table 3 – Rating Background Noise Level: Facing Pacific Hwy

Location	Time of day	Rating Background Noise Level dB(A)L₉₀
Western boundary of Level 1 awning Facing Pacific Hwy	Day (7 am – 6 pm)	59
	Evening (6 pm – 10 pm)	55
	Night (10 pm – 7 am)	44

Table 4 – Rating Background Noise Level: Facing Falcon Street

Location	Time of day	Rating Background Noise Level dB(A)L₉₀
Northern boundary at Level 3 Facing Falcon Street	Day (7 am – 6 pm)	58
	Evening (6 pm – 10 pm)	55
	Night (10 pm – 7 am)	40

For the purposes of presenting a conservative assessment, the lowest RBL from each monitor will be adopted for determining applicable construction noise management objectives (bolded in the tables above).

7 NOISE AND VIBRATION SOURCES

Typical equipment/processes anticipated to be used on the project site are outlined below. Noise impacts from these activities on the amenity of the surrounding identified sensitive receivers will be predicted based on the A-weighted sound power levels outlined in the table below.

Table 5 – Primary Construction Noise Sources

Phase/Activity	Plant
Excavation	Excavator with bucket loading truck
	Excavator mounted hydraulic hammer (5t & 20t)
	Concrete Rock Saw
	Pneumatic Handheld Jack Hammer
	Truck
	Electric Powered Hand Tools
	Skid Steer/Bobcat
	Tower Crane (electric)
Piling	Piling rig (bored piles)
Construction	Roller – Vibratory
	Concrete Pump
	Concrete Vibrators
	Heavy Trailers (idling)
	Powered Hand Tools
	Work Zone (Forklifts, Trucks, etc.)
	Generator – diesel
	Tower Crane (electric)

8 CONSTRUCTION NOISE AND VIBRATION EMISSION MANAGEMENT LEVELS

8.1 NOISE MANAGEMENT LEVELS

Noise emissions associated with construction activities on the project site to external areas of receivers will be assessed in with reference to the following:

- NSW EPA's Interim Construction Noise Guideline (DECC, 2009),
- Australian Standard AS2436:2010 "Guide to Noise Control on Construction, Maintenance and Demolition Sites.

8.1.1 2009 NSW Environmental Protection Authority (EPA) document – "Interim Construction Noise Guideline (ICNG) 2009"

The EPA's ICNG assessment requires:

- Review of noise levels at nearby development
- If necessary, recommendation of noise control strategies in the event that compliance with noise emission goals is not possible.

EPA guidelines adopt differing strategies for noise control depending on the predicted noise level at the nearest residences for construction during the recommended standard hours:

- "*Noise Affected*" level – Where construction noise is predicted to exceed the "noise affected" level at a nearby residence, the proponent should take reasonable/feasible work practices to ensure compliance with the noise affected level. For residential properties, the noise affected level occurs when construction noise exceeds the rating background noise level by more than 10dB.
- "*Highly Noise Affected*" level – Where noise emissions are such that nearby properties are "highly noise affected", noise controls such as respite periods should be considered. For residential properties, the highly noise affected level occurs when construction noise exceeds 75dB(A)_{Leq(15min)} at nearby residences.

As detailed in Section 5, only internal fitout works are scheduled on Sundays. This is unlikely to cause any additional noise impacts to the surrounding receives as all the activities are to be conducted in semi-enclosed spaces with building facades partly installed.

Where construction works are proposed to be undertaken outside of normal construction hours, the following management levels are typically adopted.

Table 6 – Construction Noise Management Levels- Out of Normal Hours

Noise Affected Management Level $L_{Aeq,(15min)}$	How to Apply
RBL + 5dB	A strong justification would typically be required for works outside the recommended standard hours. The proponent should apply all feasible and reasonable work practices to meet the noise affected level. Where all feasible and reasonable practices have been applied and noise is more than 5 dB(A) above the noise affected level, the proponent should negotiate with the community.

The guideline also provides external management levels for land used for commercial or industrial purposes to be assessed at the most affect occupied point of the premises. EPA guidelines recommend a construction noise management level for commercial receivers (offices, retail outlets, etc) of 70dB(A) $L_{eq(15-minute)}$.

8.1.2 Construction Noise Management Levels Summary

Nosie management levels applicable to the development site and surrounding receivers are summarised in the following table:

Table 7 – Construction Noise Management Levels

Receiver Type	Noise Management Level Standard Construction Hours dB(A) $L_{eq(15min)}$	Noise Management Level Outside of Standard Construction Hours dB(A) $L_{eq(15min)}$
R1 – R2 Residential	<u>Noise Affected Level</u> 68 (Externally) <u>Highly Noise Affected Level</u> 75 (Externally)	63 (Externally) Saturday (7am-8am) & (1pm-5pm) & Sunday (8am-5pm)
C1-C6 Commercial	70 (Externally)	N/A

If noise levels exceed the management levels identified in the table above, reasonable and feasible noise management techniques shall be reviewed.

8.2 VIBRATION OBJECTIVES

Vibrations caused by any proposed activities on site, at the façade or incident on the structure of any surrounding sensitive receivers, will be assessed against the following provisions:

- Sydney Metro Sydney Metro Underground Corridor Protection Technical Guidelines (Ref: iCentral SM-20-00081444), dated April 2021.
- For structural damage vibration, German Standard DIN 4150-3 *Structural Vibration: Effects of Vibration on Structures*.
- For human exposure to vibration, the evaluation criteria presented in Department of Environment and Conservation document – ‘*Assessing Vibration- A technical guideline.*’
- British Standard BS 7385 Part 2-“1993 *Evaluation and Measurement for Vibration in Buildings. Part 2. Guide to damage levels from ground borne vibration,*”

The criteria and the application of these guidelines are discussed in separate sections below.

8.2.1 Sydney Metro Underground Corridor Protection Technical Guidelines, (Ref: iCentral SM-20-00081444)

Section 9.3 of the Sydney Metro document *Sydney Metro Underground Corridor Protection Technical Guidelines* states the following:

9.3.1 Considerations during development construction

Sydney Metro refers to Australian Standard AS2187: Part2-2006 ‘Explosives – Storage and Use – Part 2: Use of Explosives’, which recommends the frequency dependent guideline values and assessment methods given in BS 7385 Part 2 – 1993 ‘Evaluation and measurement for vibration in buildings Part 2’ as they “are applicable to Australian conditions”.

The Standard sets guide values for building vibration based on the lowest vibration levels above which damage has been credibly demonstrated.

The recommended limits for transient vibration to ensure minimal risk of cosmetic damage to reinforced or framed structures and industrial and heavy commercial buildings apply to Sydney Metro infrastructure.

Sources of vibration that are considered in the standard include demolition, piling, ground treatments (e.g. compaction), construction equipment, tunnelling and industrial machinery.

Continuous rock-breaking/hammering and sheet piling, vibratory rollers, excavators and the like can give rise to dynamic magnification due to resonance.

An adjusted peak particle component velocity (PPV) of 20 mm/s at 4 Hz and above applies to any development that occurs within 25 m horizontally from first reserve of Sydney Metro infrastructure as a conservative vibration damage screening level. An Alert level of 15 mm/s shall apply for monitoring and management purposes.

8.2.2 Development Near Rail Tunnels (Ref: T HR CI 12051 ST)

Sections 9.4.1 and 9.4.2 of the report provided the following guidelines for vibration impact of developments on rail tunnels:

9.4.1 Effects of development on rail tunnels

Any development that occurs within a distance of 25 m horizontally from first reserve shall assess the vibration on the rail tunnels. The assessment criteria shall be a maximum peak particle velocity (PPV) of 15 mm/s at the tunnel lining for brick or mass concrete in good condition or a maximum PPV of 20 mm/s at the tunnel lining for cast iron, steel or concrete segment lining.

9.4.2. Construction vibration monitoring

During construction, vibration monitoring of works at the tunnel lining shall be conducted with appropriate trigger levels. If the vibration levels exceed the tolerable limits, then the developer shall modify the construction methodology in such a way that the vibration limits are satisfied.

8.2.3 German Standard DIN 4150-3 (2016) - Ground Borne Vibrations and Damage Limits

German Standard DIN 4150-3 (2016) provides a guideline for acceptable levels of vibration velocity in building foundations, to assess the effects of vibration on structures. The table below provides guidance on the maximum accepted values of velocity at the foundation and in the plane of the highest floor of various types of buildings, to prevent any structural damage.

The table below lists the peak particle velocity, which is the maximum absolute value of the velocity signals for the three orthogonal components. This is measured as a maximum value of any of the three orthogonal component particle velocities when measured at the foundation, and the maximum levels measured in the x- and y-horizontal directions in the plane of the floor of the uppermost storey.

It is noted that if measured vibration levels are below the guidelines listed below, damage that will reduce the serviceability of the building will not occur and if damage to the building does occur, it is assumed that the damage is related to other activities or sources. Furthermore, the DIN4150-3 guideline states the following regarding the limits presented in Table 1 of the standard:

"Exceeding the guideline values does not necessarily lead to damage. Should they be exceeded, however, further investigations may be necessary, such as determining and evaluating the stresses as detailed in 4.3 and 4.4."

Table 8 -(DIN 4150-3 (2016)) – Guideline Values for Vibration Velocity, $v_{i,max}$, for Evaluating the Effects of Short-Term Vibration on Structures

	TYPE OF STRUCTURE	Guideline values for $v_{i,max}$ in mm/s				
		Foundation, all directions, $i = x, y, z,$ at a frequency of			Topmost floor, horizontal direction, $i = x, y$	Floor slabs, vertical direction, $i = z$
		1Hz to 10Hz	10Hz to 50Hz	50Hz to 100Hz ^(a)	All Frequencies	All Frequencies
L/C	1	2	3	4	5	6
1	Buildings used for commercial purposes, industrial buildings, and buildings of similar design	20	20 to 40	40 to 50	40	20
2	Residential buildings and buildings of similar design and/or occupancy	5	5 to 15	15 to 20	15	20
3	Structures that, because of their particular sensitivity to vibration, cannot be classified under lines 1 and 2 and are of great intrinsic value (e.g. listed buildings) buildings that are under a preservation order) i.e. Heritage	3	3 to 8	8 to 10	8	20 ^(b)

NOTE Even if guideline values as in line 1, columns 2 to 5, are complied with, minor damage cannot be excluded.

a At frequencies above 100 Hz, the guideline values for 100 Hz can be applied as minimum values.

b It may be necessary to lower the guideline value markedly to prevent minor damage

8.2.3.1 Assessing Amenity

The NSW Environment Protection Authority's (EPA) publication "Assessing Vibration: A Technical Guideline" outlines vibration criteria to assess the effects on human exposure to vibration from industry, transportation and machinery. This will ensure the amenity of tenants within surrounding residential properties is not adversely impacted.

This document classifies vibrations in buildings into continuous (with magnitudes varying or remaining constant with time), impulsive (such as shocks) or intermittent (with the magnitude of each event being either constant or varying with time). Criteria stipulated in this publication is based on the type of vibrations generated by the source.

Criteria relevant to the proposed excavation and construction activities on site are detailed below.

Table 9 – EPA Recommended Human Comfort Vibration Criteria

		RMS acceleration (m/s ²)		RMS velocity (mm/s)		Peak velocity (mm/s)	
Place	Time	Preferred	Maximum	Preferred	Maximum	Preferred	Maximum
Continuous Vibration							
Residences	Daytime	0.01	0.02	0.2	0.4	0.28	0.56
Offices		0.02	0.04	0.4	0.8	0.56	1.1
Workshops		0.04	0.08	0.8	1.6	1.1	2.2
Impulsive Vibration							
Residences	Daytime	0.3	0.6	6.0	12.0	8.6	17.0
Offices		0.64	1.28	13.0	26.0	18.0	36.0
Workshops		0.64	1.28	13.0	26.0	18.0	36.0

8.2.4 Construction Noise Management Levels Summary

Table 10 – Vibration Management Levels

Receiver Type	Vibration Management Level
Residential	<p style="text-align: center;"><u>Alert Level</u> 4.25mm/s</p> <p style="text-align: center;"><u>Stop Works Level</u> 5mm/s</p>
Commercial	<p style="text-align: center;"><u>Alert Level</u> 12.75mm/s</p> <p style="text-align: center;"><u>Stop Works Level</u> 15mm/s</p>
Sydney Metro Assets	<p style="text-align: center;"><u>Alert Level</u> 12.75mm/s</p> <p style="text-align: center;"><u>Stop Works Level</u> 15mm/s</p>

A summary of actions to be undertaken at each of the alert and alarm levels are provided below:

Alert level – The builder is to review activities undertaken on site. If vibration is not expected to increase or event was a one-off impact, works can continue. If vibration is expected to increase, relevant stakeholders are to be informed.

Stop Works level – The builder is to stop work and review activities undertaken on site. If vibration was found to be due to works, alternative processes are to be considered. Relevant stakeholders are to be informed.

9 CONSTRUCTION NOISE AND VIBRATION ASSESSMENT

9.1 GENERAL

A quantitative evaluation of the proposed works has been undertaken to identify those activities that have the potential to adversely impact nearby properties. The outcomes of the assessment have been used to develop a management plan to minimise adverse noise and vibration impacts.

The assessment uses site specific noise and vibration management levels developed using the EPA ICNG and Assessing Vibration and DIN4150 guidelines. The predicted, receiver noise and vibration levels will be compared to the management levels to identify those activities that are likely to require additional management, above what is considered to be normal good practice.

9.2 CONSTRUCTION NOISE ASSESSMENT

9.2.1 Noise Predictions

Construction noise emissions to nearby development depend on the activities being undertaken at the time, and where on the site the activities occur.

Construction noise levels at the surrounding receivers have been predicted based on the following inputs.

- The plant sound power levels indicated in Appendix A. These have been corrected for estimated typical operation duty indicated in the table using $10 \times \log(\% \text{ duty}/100)$.
- Barrier or directivity attenuation where present.
- Treatments detailed in Sections 12.2 and 12.7 are adopted.

9.2.2 Predicted Noise Impacts

The predicted noise levels are summarised in the following tables for the nearest noise sensitive receivers. Remaining receivers are expected to be exposed to a lower level of noise impact given they are located further away.

Table 11 – Predicted Noise Impacts – (R1 – Residential)

Stage of Work	Activity	Predicted Internal Level dB(A)	Noise Management Level dB(A) L_{eq}	Comment
Excavation	Excavator with bucket loading truck	53 to 60 (external)	<p align="center"><i>Noise Affected Level</i> 68 (Externally)</p> <p align="center"><i>Highly Noise Affected Level</i> 75 (Externally)</p> <p align="center"><i>Outside of Standard Construction Hours Noise Management Level</i> 63 (Externally) Saturday (7am-8am) & (1pm-5pm) & Sunday (8am-5pm)</p>	Below Noise Affected Level all the time
	Excavator mounted hydraulic hammer	67 to 74 (external)		Below Highly Noise Affected Level 75dB(A)
	Concrete Rock Saw	<u>69 to 76 (external)</u>		Exceeds Highly Noise Affected Level 75dB(A) when working along Alexander Street
	Pneumatic Handheld Jack Hammer	65 to 72 (external)		Below Highly Noise Affected Level 75dB(A)
	Truck	54 to 61 (external)		Below Noise Affected Level all the time
	Electric Powered Hand Tools	47 to 54 (external)		Below Noise Affected Level during normal construction hours.
	Skid Steer/Bobcat	61 to 68 (external)		
	Tower Crane	66 to 67 (external)		
Piling	Piling rig – (bored)	61 to 68 (external)		
Construction	Roller – Vibratory	61 to 68 (external)		Below Highly Noise Affected Level 75dB(A)
	Concrete Pump	65 to 72 (external)		Exceeds Highly Noise Affected Level 75dB(A) when working along Alexander Street See discussion below
	Concrete Vibrators	<u>69 to 76 (external)</u>		Slightly exceed Saturday outside of standard construction hours noise management level
	Heavy Trailers (idling)	57 to 64 (external)		Below Noise Affected Level all the time
	Powered Hand Tools	47 to 54 (external)		Below Noise Affected Level during normal construction hours. Exceed Saturday outside of standard construction hours noise management level
	Work Zone (Forklifts, Trucks, etc.)	59 to 66 (external)		
	Generator – diesel	57 to 64 (external)		
	Tower Crane	66 to 67 (external)		

Table 12 – Predicted Noise Impacts – (R2 – Residential)

Stage of Work	Activity	Predicted Internal Level dB(A)	Noise Management Level dB(A) L _{eq}	Comment
Excavation	Excavator with bucket loading truck	53 to 56 (external)	<p>Noise Affected Level 68 (Externally)</p> <p>Highly Noise Affected Level 75 (Externally)</p> <p>Outside of Standard Construction Hours Noise Management Level 63 (Externally) Saturday (7am-8am) & (1pm-5pm) & Sunday (8am-5pm)</p>	Below Noise Affected Level at all time
	Excavator mounted hydraulic hammer	67 to 71 (external)		Below Highly Noise Affected Level 75dB(A)
	Concrete Rock Saw	69 to 72 (external)		
	Pneumatic Handheld Jack Hammer	65 to 69 (external)		Below Noise Affected Level at all time
	Truck	54 to 57 (external)		
	Electric Powered Hand Tools	47 to 51 (external)		Slightly exceed Saturday outside of standard construction hours noise management level
	Skid Steer/Bobcat	61 to 64 (external)		Below Noise Affected Level at all time
	Tower Crane	62 to 61 (external)		
Piling	Piling rig – (bored)	61 to 65 (external)		Below Noise Affected Level
Construction	Roller – Vibratory	61 to 65 (external)		Below Highly Noise Affected Level 75dB(A)
	Concrete Pump	65 to 65 (external)		Below Noise Affected Level at all time
	Concrete Vibrators	69 to 69 (external)		
	Heavy Trailers (idling)	57 to 60 (external)		
	Powered Hand Tools	47 to 51 (external)		
	Work Zone (Forklifts, Trucks, etc.)	59 to 63 (external)		
	Generator – diesel	57 to 59 (external)		
	Tower Crane	62 to 61 (external)		

Table 13 – Predicted Noise Impacts – (C1-C6 –Commercial)

Stage of Work	Activity	Predicted Internal Level dB(A)	Noise Management Level dB(A) L _{eq}	Comment	
Excavation	Excavator with bucket loading truck	53 to 60 (external)	70 (Externally)	Below Noise Management Level 70dB(A)	
	Excavator mounted hydraulic hammer	<u>67 to 74 (external)</u>		Exceeds Noise Management Level 70dB(A) when working along site boundary See discussion below	
	Concrete Rock Saw	<u>69 to 76 (external)</u>		Below Noise Management Level 70dB(A)	
	Pneumatic Handheld Jack Hammer	<u>65 to 72 (external)</u>			
	Truck	54 to 61 (external)			
	Electric Powered Hand Tools	47 to 54 (external)			
	Skid Steer/Bobcat	61 to 68 (external)			
	Tower Crane	66 to 67 (external)			
Piling	Piling rig – (bored)	61 to 68 (external)			Exceeds Noise Management Level 70dB(A) when working along site boundary See discussion below
Construction	Roller – Vibratory	61 to 68 (external)		Below Noise Management Level 70dB(A)	
	Concrete Pump	<u>65 to 72 (external)</u>			
	Concrete Vibrators	<u>69 to 76 (external)</u>			
	Heavy Trailers (idling)	57 to 64 (external)			
	Powered Hand Tools	47 to 54 (external)			
	Work Zone (Forklifts, Trucks, etc.)	59 to 66 (external)			
	Generator – diesel	57 to 64 (external)			
	Tower Crane	66 to 67 (external)			

9.2.3 Discussion of Predicted Results – Noise

The predicted noise levels presented in the above table have considered the additional noise attenuation obtained from treatments presented in Sections 12.2 and 12.7. These include acoustic barrier/hoarding, crane engine enclosure, acoustic screen scaffolding, etc.

The analysis of the results indicates that:

- The activities with the greatest potential noise impacts on surrounding receivers have been identified as hydraulic/pneumatic hammering, use of concrete rock saws and jackhammer, and concrete pumping and concrete vibrators, especially when working near the site boundary. We note that works conducted with these plant items will predominantly occur during a relative short period (i.e., excavation phase only). Furthermore, as stated in condition D6, above high noise generated activities are not to occur during the proposed extension of construction hours (Saturday 7am-8am & 1pm-5pm), hence, there is minimal noise impact associated with the proposed extended hours of construction work.
- During the proposed extension of construction hours on Sundays, construction noise levels at residents will be below the NML given all proposed works are internal.
- Noise levels from the use of powered hand tools are likely to decrease as construction progresses to higher levels and once the external façade of the building is installed. Reductions of up to -20dB can be expected when this occurs.

There are a number of predictions above the noise objectives at the nearest receivers. To assess whether mitigation of these predicted results is feasible or reasonable, the IGNG indicates the following should be considered:

- The levels of impact including noise levels and the number of people affected.
- The benefits of noise mitigation and the number of people protected.
- Cost effectiveness of mitigation.
- Community views.

The most effective mitigation investigation strategies are likely to be:

- Select the quietest plant/activity available (or retrofit acoustic treatment to the plant such as residential class mufflers) to minimise any risk of exceeding the NML's.
- Investigate time restrictions (e.g. avoiding loud early morning works at the residences) and notification of affected receivers when works likely to exceed the NML's is likely to occur.

Detailed site-specific noise control methods are presented in Sections 12.2 and 12.7.

9.3 CONSTRUCTION VIBRATION

9.3.1 Vibration Sources

The following sources have been identified as potentially producing significant ground vibration:

- Hydraulic hammering (with excavator)
- Pneumatic jackhammering
- Concrete rock saw cutting
- Bored piling rig
- Vibratory roller

The remaining activities are not expected to produce significant ground vibration and/or are sufficiently separated from sensitive receivers. Vibration from these activities is expected to be significantly below amenity or damage risk management levels at all receivers.

9.3.2 Assessment of Vibration

A precise assessment of vibration emissions from the proposed works is not possible due to the large number of unknowns including the actual equipment employed, how it is operated, site conditions, etc.

Site vibration levels from machinery and processes should be verified on site as soil conditions may be different from the basis sources.

The assessment of building and soil settlement or the liquefaction of soils under induced vibration is outside the scope of typical vibration standards such as DIN 4150-3 and expert advice is to be sought from a Geotechnical Engineer.

For Sydney Metro assets - additional mitigation measures shall be taken in order to ensure assets remain protected (i.e. on-site vibration monitoring and establishment of "safe" working zones based on minimum working distances for specific machinery).

10 NOISE AND VIBRATION MANAGEMENT PLAN

The project specific noise and vibration management plan should be implemented to manage noise and vibration impacts. The Plan should be revised as the works proceed in response to changing or latent conditions and to incorporate the results of additional analysis, monitoring or modified work practices implemented to minimise impacts.

The management plan has been prepared in accordance with ICNG guideline and includes:

- Identification of sensitive receivers and applicable noise and vibration management levels
- A description of the main noise or vibration producing activities, processes and equipment that will be employed and an indicative construction programme.
- Proposed construction hours.
- A prediction of likely noise/vibration levels at the most impacted receivers.
- The assessment and recommendation of mitigation methods to be applied where the predicted levels exceed the management levels, as indicated below.
- A monitoring plan including the type and extent of monitoring, reporting procedures.
- Recommended management procedures including complaints handling, response to monitoring exceedances, reporting, site training, etc.
- Community liaison.

11 NOISE AND VIBRATION MONITORING, REPORTING AND RESPONSE PROCEDURES

Noise and vibration monitoring may either consist of attended and/or unattended measurements. Active monitoring may be undertaken during the construction work phase of the project if required in the event complaints are received from neighbours.

In the event that complaints are received from neighbours the following process should be considered:

1. Assessing impacts and determining the offending plant/equipment/process and.
2. Locating the plant/equipment/process further away from the affected receiver(s) if possible.
3. Implementing additional acoustic treatment in the form of localised barriers, silencers etc.
4. Selecting alternative equipment/processes

Where monitoring is required and indicates exceedances of the predicted noise impacts immediate action should be taken to identify any further controls as required to reduce noise emissions so that the noise limits are complied with. Monitoring of the activities following the implementation of these additional controls will be undertaken to confirm compliance.

11.1 REPORTING REQUIREMENTS

The following is an example of reporting which may be kept on site;

1. A register of complaints received/communication with the local community shall be maintained and kept on site with information as detailed below. The head contractor shall provide regular updates or notices in advance of any noise or vibration intensive work that will occur for long periods of time.
2. Where noise/vibration complaints require noise/vibration monitoring, results from monitoring shall be retained on site at all times. Monitoring is to provide alerts to relevant contractors on site in the event of exceedances.
3. Any noise exceedances occurring including, the actions taken and results of follow up monitoring.
4. A report detailing complaints received and actions taken shall be presented.
5. All monitoring and reporting shall be conducted in conjunction with the conditions of consent.

11.2 RESPONSE PROCEDURES

Complaints associated with noise and vibration generated by site activities shall be recorded on a Noise Complaint Form. The person(s) responsible for complaint handling and contact details for receiving of complaints shall be established on site prior to construction works commencing. A sign shall be displayed at the site indicating the Site Manager and the general public and their contact telephone number

If a noise complaint is received the complaint should be recorded on a Noise Complaint Form. The complaint form may list:

- The name and address of the complainant (if provided).
- The time and date the complaint was received.
- The nature of the complaint and the time and date the noise was heard.
- The name of the employee who received the complaint.
- Actions taken to investigate the complaint, and a summary of the results of the investigation.
- Indicate what operations were occurring on site at the time of the complaint.
- Required remedial action, if required
- Validation of the remedial action.
- Summary of feedback to the complainant.

12 NOISE AND VIBRATION MANAGEMENT AND CONTROL

The flow chart that follows illustrate the process followed to assess construction activities prior to the start of work on site, and for the ongoing investigation of noise and vibration impacts during the construction period.

The ICNG recommends “feasible and reasonable” mitigation measures to be implemented where works generate noise levels above the out of normal hours NML but does not specify what mitigation measures or to what extent these measures should be applied.

12.1 GENERAL NOISE CONTROL METHODS

The determination of appropriate additional noise control measures will be dependent on the particular activities and the construction equipment and plant identified as requiring future acoustic treatments to those already identified in this report. This section provides an outline of available methods which have previously been used on similar construction sites and may be possible on this site.

12.1.1 Selection of Alternate Appliance or Process

Where a particular activity or plant and equipment is found to generate noise levels that exceed the management levels, it may be possible to select an alternative approach or plant and equipment. For example; the use of excavator mounted hydraulic hammers of the site may potentially generate high levels of noise. By carrying this activity by using concrete saws or smaller plant here practical, construction noise levels and/or length of exposure to construction noise levels may be reduced.

12.1.2 Acoustic Barriers

The placement of barriers at the source is generally only effective for static plant. Placing barriers at the source cannot effectively attenuate equipment which is on the move or working in rough or undulating terrain.

The degree of noise reduction provided by barriers is dependent on the amount by which the line of sight can be blocked by the barrier. If the receiver is totally shielded from the noise source reductions of up to 15 dB(A) can be effected. Where only partial obstruction of line of sight occurs, noise reductions of 5 to 8 dB(A) may be achieved. Where the barrier does not obstruct line of sight, generally no noise reduction will occur.

Barriers are used to provide shielding and do not act as an enclosure. The material they are constructed from should have a noise reduction performance which is approximately 10dB(A) greater than the maximum reduction provided by the barrier screening. In this case, the use of a material such as 15mm plywood (or equivalent material) would be acceptable for the barriers.

12.1.3 Silencing Devices

Where construction methodologies or plant and equipment permit, investigate the use of silencing devices. These may take the form of engine shrouding, or special industrial silencers fitted to exhausts, for example.

12.1.4 Treatment of Specific Equipment

In certain cases it may be possible to specially treat a piece of equipment to dramatically reduce the sound levels emitted.

12.1.5 Establishment of Site Practices

This involves the formulation of work practices to reduce noise generation. This includes, for example, investigating the possibility of locating fixed plant items as far as possible from residents, rotating plant and activities to provide respite to receivers, scheduling activities after the construction of buildings that will screen receivers, avoiding noise sensitive periods for receivers, identify "safe" working distances, etc.

12.1.6 Vibration Management

The following principles should be considered to manage adverse vibration impacts identified:

- Obtaining separate structural or specialist advice for critical or fragile structures as to the level of damage risk.
- Selection of processes that minimise structure and ground vibration – generally avoiding percussive methods.
- Use smallest plant that is able to efficiently undertake the work activity.
- Lay vibration absorbing mats to cushion impacts from falling debris.
- Application of vibration dampening pads to metal surfaces subject to impacts.
- When demolishing, cut control joints in structures to form vibration "breaks", or work away from sensitive receiver locations to form natural vibration breaks in propagation path.
- Monitoring of structures using attended and/or unattended monitors with alarms.
- Time scheduling works to minimise amenity impacts.
- Communicating with affected receivers.

12.2 SPECIFIC NOISE CONTROLS AND METHODOLOGY

The following specific noise controls are recommended during proposed construction work:

- 1) Crane noise control – These treatments are to consist of the following (or similar):

A three-sided screen and bottom covering enclosure for the engine. The screen/bottom can be constructed from 15mm plywood lined with 50mm thick Tontine Acousticsorb 2 or equal.

The engine exhaust can be treated with an additional muffler if required, however it appears that piping the exhaust up to the upper section of the crane is adequate. This can only be confirmed once the plywood is installed.

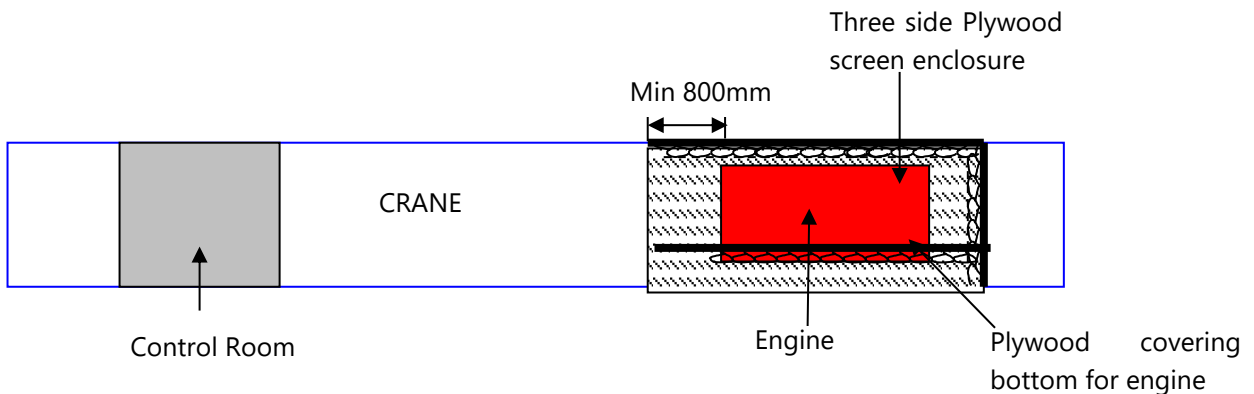

The required treatments will be developed as required based on site measurements.

- 2) Overall site containment; The 'B Class' hoarding along the Alexander Street needs to be 'high-bay' 6 metres high constructed in solid form timber ply.

12.3 RECOMMENDED NOISE AND VIBRATION MONITORING

Where noise or vibration monitoring is required, the following minimum requirements should be adhered to.

12.3.1.1 Vibration Criteria

It is recommended to adopt DIN 4150-3 'Type 2' criteria to protect residential buildings and 'Type 1' to protect commercial buildings adjacent to the project site.

Residential levels (Hotel/Mixed Use receivers):

- Alarm Level – 4.25mm/s PPV at vibration at receiver location, SMS alarm message will be sent to operator, project manager and acoustic engineer if magnitude of vibration events exceed this level. Project manager shall respond immediately by taking courteous work methodology.
- Stop work level - 5mm/s PPV at vibration at receiver location, SMS alarm message will be sent to operator, project manager and acoustic engineer if magnitude of vibration events exceed this level. Project manager shall stop the work at amenity of geophone immediately.

Commercial levels:

- Alarm Level – 15mm/s PPV at vibration at receiver location, SMS alarm message will be sent to operator, project manager and acoustic engineer if magnitude of vibration events exceed this level. Project manager shall respond immediately by taking courteous work methodology.
- Stop work level - 20mm/s PPV at vibration at receiver location, SMS alarm message will be sent to operator, project manager and acoustic engineer if magnitude of vibration events exceed this level. Project manager shall stop the work at amenity of geophone immediately.

12.3.1.2 Vibration Monitoring Type

The proposed vibration monitoring equipment is a Texcel type with externally mounted geophones installed at the nearest affected receivers.

The monitors are proposed to be fitted with GSM modems and will remotely signal up to five mobile phones indicating any exceedance in the prescribed vibration criteria. In addition, the vibration loggers will be downloaded remotely using the GSM modem.

12.3.1.3 Noise Monitoring Type

Noise monitoring will be conducted using RION type noise loggers. All monitoring equipment used retains current calibration, either manufacturers' calibration or NATA certified calibration.

The monitors are to be fitted with a Type-1 microphone at a minimum height of 1.5m

12.3.1.4 Dust Monitoring Type (if required)

If required, dust monitoring may be conducted using SiteHive Hexanode monitors. Monitors are programmed to continuously store noise data over every 15-minute period and are capable of sending SMS alerts where project dust limits (to be established at a future date if needed) are exceeded.

12.3.1.5 Downloading of Logger Data

Downloading of the noise/vibration/dust monitoring loggers will be conducted on a regular basis. In the event that exceedances of vibration criteria or alarms occur, downloading of logger will be conducted more frequently. Results obtained from the vibration monitor will be presented in a graph format and will be forwarded to Deicorp for review. It is proposed that reports are provided fortnightly with any exceedance in the vibration criteria reported as detailed in this report.

12.3.1.6 Presentation of Logger Results

A fortnightly report will be submitted to the nominated builder via email summarising the vibration events. Complete results of the continuous vibration logging will be presented in fortnightly reports including graphs of collected data.

12.3.1.7 Monitoring Alert Recipients

The following personnel will receive GSM alarms (note: A test knock capable of triggering alert levels on the sensor is to be carried out prior to the start of vibration generating works to confirm the system's operation).

- Acoustic consultant/advisor (1 person)
- Site foreman
- Main builder foreman (where applicable)
- Deicorp nominated representative(s)
- Sydney Metro nominated representative(s)

12.4 SYDNEY METRO – SPECIFIC MONITORING AND RESPONSE PROCEDURES

The sections below are in addition to those outlined above.

12.4.1 Vibration Monitoring Locations – Sydney Metro Assets

Indicative noise monitoring locations are provided in the figure below:

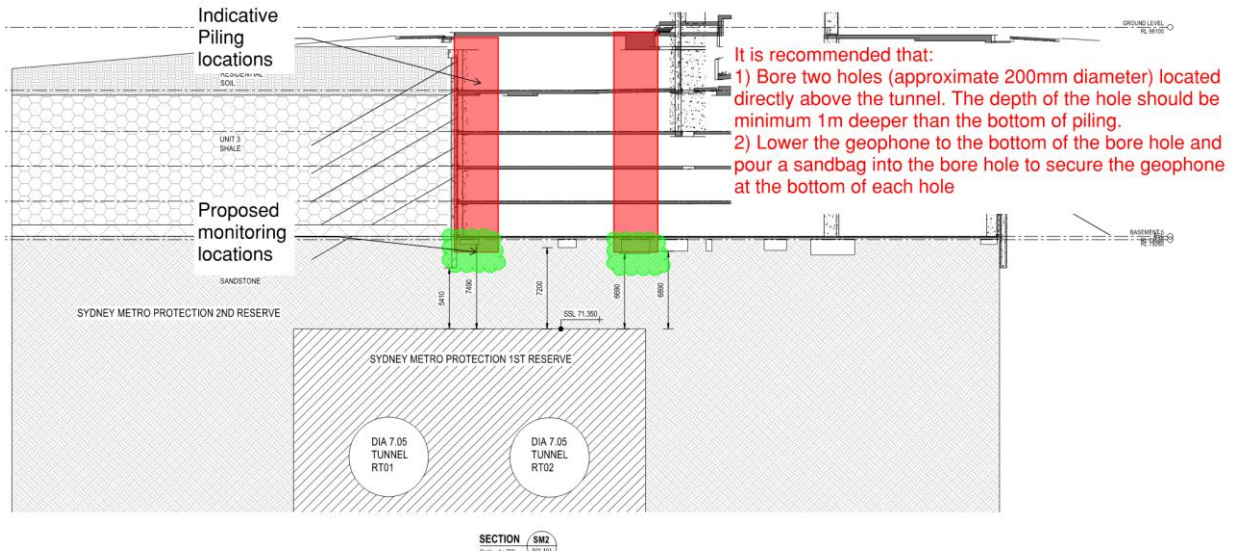

Figure 2 – Indicative Locations for Vibration Monitors during Excavation Stage

In the event that the vibration levels associated with works on the project site exceed the project vibration criteria within the metro tunnel or station, the event will be remotely forwarded nominated recipients. This will warn that an event exceeding the pre-set alarm level has occurred.

After an event within this magnitude range the procedure to be followed is:

Warning Alarm Triggers (12.5mm/s PPV)

- The builders will immediately stop all activities within the immediate area near to where the exceedance occurred. Sydney Metro and the Acoustic Logic should be notified and will verify data received by other recipients, namely the Project manager, Sydney Metro, etc. Recent event data from the remote vibration monitor will also be downloaded.
- The builder and AL shall conduct site investigation immediately. The cause of the vibration exceedance shall be found and analysed from the recorded data and site works notes. Vibration mitigation methods and/or change in work methodology will then be advised.
- A phone call to the nominated Sydney Metro representative is to be made within one hour of SMS alarm, followed by an incident report explaining how the alarm was triggered. This report will be required to be presented to the nominated representatives (TBD) within 24 hours of the SMS alarm being issued. This report should include the following information:
 - 1) Date, time and identity of the alarm.
 - 2) The cause of the alarm.
 - 3) What recommendation is given to prevent the alarm level being reached again?
 - 4) What actions the Site Manager is taking to ensure the alarm levels is not reached again?

- Trial vibration testing will be carried out after the implementation of any vibration mitigation measures or changes in procedure. Measurements of vibration during the trial will be carried out on the surface and results will be compared to in tunnel/station recordings to ensure safe working vibration levels.
- Works will only be allowed to proceed in the area where the exceedance occurred once the work methods and restrictions to work zones of equipment or any other recommendations have been implemented to the satisfaction of Acoustic Logic. Sydney Metro will be notified of all Acoustic Logic recommendations via the Investigation Report.

Vibration Level Exceeded 15mm/s PPV

From the time an alarm event occurs the following procedure will be followed:

- The builders will immediately stop all activities within the immediate area that the exceedance occurred and contact Sydney Metro. Note the remote GSM transmission from the GSM modem in the vibration logger would already have been received by the acoustic consultant, Sydney Metro, Project Manager, etc.
- The builder and AL shall conduct site investigation immediately. The cause of the vibration exceedance shall be analysed, and vibration mitigation method shall be worked out.
- A phone call to the Sydney Metro representatives is to be made immediately. If the public is likely to be affected and during emergency incidents, then the train Control Room Sydney Metro (Operating Centre) must be contacted in addition to what has been already mentioned above. Sydney Metro will also conduct a safety/ engineering investigation into the incident.
- A review of work procedures will be conducted and restrictions limiting the working zones of equipment updated if required. Additionally, alternative methods of work will be devised to complete the required works so as vibration criteria will not be exceeded. Detailed revised work methods and required remediation works shall be reviewed by Sydney Metro.
- Works will only be allowed to proceed in the area where the exceedance occurred once work methods and restrictions to work zones of equipment have been agreed by Sydney Metro. Trial vibration testing shall be conducted, and the testing report shall be submitted to Sydney Metro.
- Works will only be allowed to proceed in the area where the exceedance occurred once work methods and restrictions to work zones of equipment have been agreed by the Sydney Metro.

12.5 MANAGEMENT FLOW CHART – NOISE AND VIBRATION

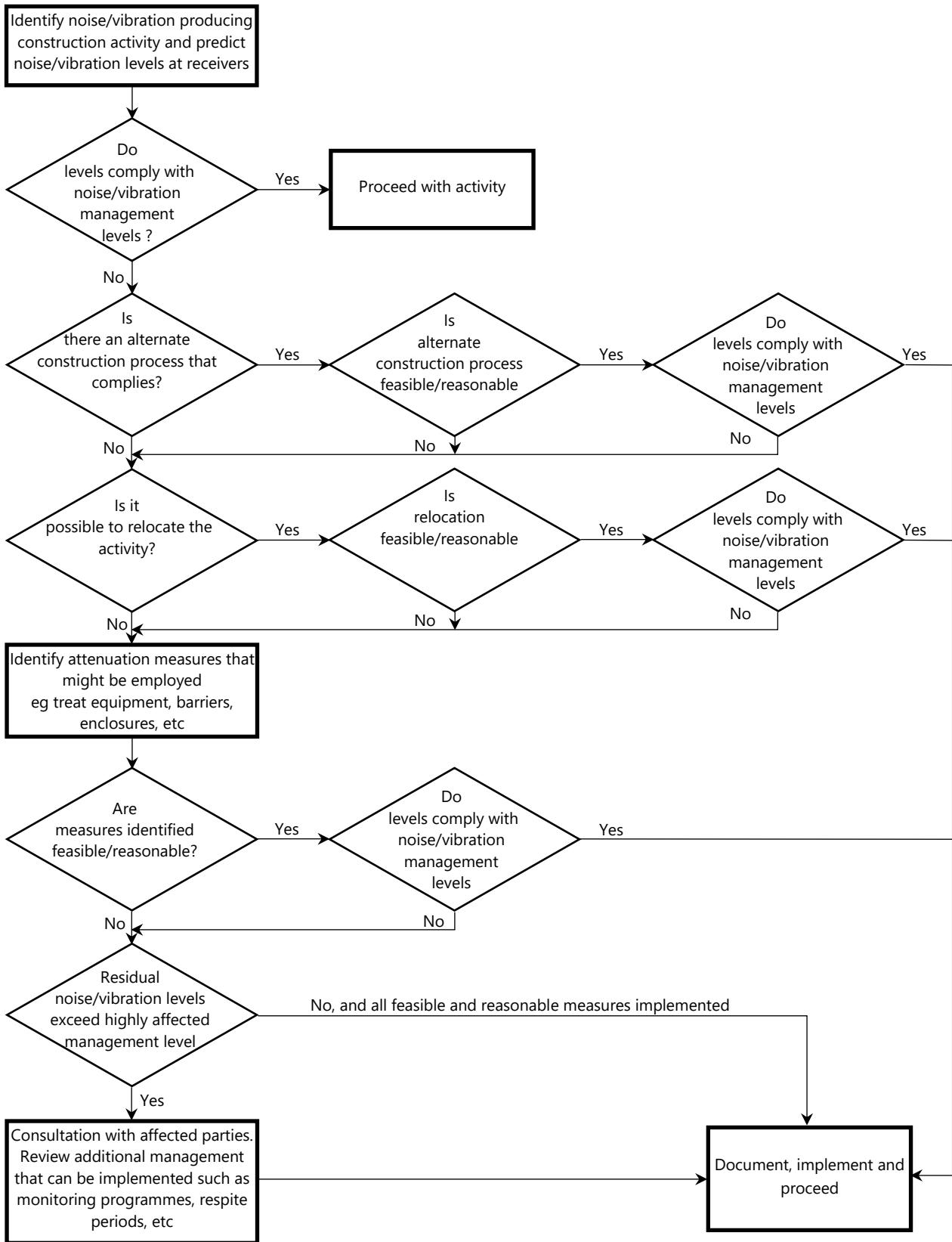

Noise and Vibration Management Flow Chart

12.6 COMMUNITY LIAISON AND COMPLAINTS HANDLING

Notification of the anticipated commencement and duration of the proposed construction works is recommended.

Should ongoing complaints of excessive noise or vibration criteria occur immediate measures shall be undertaken to investigate the complaint, the cause of the exceedances and identify the required changes to work practices. In the case of exceedances of the vibration limits all work potentially producing vibration shall cease until the exceedance is investigated.

If a noise complaint is received the complaint should be recorded on a Noise Complaint Form and kept in a register. The complaint form should list:

- The name and address of the complainant (if provided);
- The time and date the complaint was received;
- The nature of the complaint and the time and date the noise was heard;
- The name of the employee who received the complaint;
- Actions taken to investigate the complaint, and a summary of the results of the investigation;
- Required remedial action, if required;
- Validation of the remedial action; and
- Summary of feedback to the complainant.

12.7 SUMMARY OF MITIGATION

The project specific mitigation and management to be adopted is summarised in this section. Relevant contractors and suitably qualified acoustic consultants for the project shall ensure that the following mitigation and management is adopted during the construction process.

1. **Community Consultation/Notification:** Notification (leaflet or similar) of nearby residents is recommended, detailing the duration of excavation works and schedule of planned use of hydraulic hammer. Although exceedances of the noise management levels are expected at surrounding receivers, the relatively short duration of excavation works would not require any further mitigation measures.

2. **Barrier:** Class B hoarding with minimum height of 2.4m are recommended along the full perimeter of the site. 6m high 'high-bay' barriers are to be constructed in solid form timber ply along Alexander Street to mitigate noise impact to R1.

3. **Respite Periods:** To reduce the impacts on the amenity of the surrounding receivers, it is recommended that respite periods are introduced when works involving hydraulic hammer, rock saw, concrete pump and concrete vibrators are to occur. These periods are (in line with condition D6 requirement):

Monday – Friday: 7:00 am – 8:00 am

Monday – Saturday: 12:00 pm – 1:00 pm

Monday – Friday: 5:00 pm – 6:00 pm

4. **Quiet Work Methods/Technologies:**

a. The primary noise generating activity at the site will be the use of hydraulic hammer. As much as practicable, use of quieter excavation methods is to be adopted.

b. It is recommended to use rock saws near all boundaries to reduce vibration and noise levels if required.

c. Materials handling/vehicles:

i. Trucks and bobcats to use a non-tonal reversing beacon (subject to OH&S requirements) to minimise potential disturbance of neighbours.

ii. Avoid careless dropping of construction materials into empty trucks.

iii. Trucks, trailers and concrete trucks (if feasible) should turn off their engines during idling to reduce noise impacts (unless truck ignition needs to remain on during concrete pumping).

5. **Complaints Handling:** In the event of complaint, the procedures outlined in Sections 9 and 11 should be adopted.

6. **Site Induction:**

a. A copy of the Noise Management Plan is to be available to contractors. The location of the Noise Management Plan should be advised in any site induction.

b. Site induction should also detail the site contact in the event of noise complaint.

7. **Noise and Vibration Monitoring:** Ongoing vibration monitoring are recommended. Refer to details in Section 12. Ongoing noise monitoring can be conducted if complaints are received from nearby receivers.

13 CONCLUSION

This report assesses potential construction noise and vibration impacts from the proposed extend construction hours at 391-423 Pacific Highway, Crows Nest. The assessment uses the methodology outlined in the EPA ICNG to determine the appropriate noise and vibration management levels and identify the activities that are most likely to impact nearby receivers.

The outcomes of the assessment have been used to prepare a management plan that should be adopted and refined to minimise the extent impacts when feasible and reasonable.

The assessment indicates that:

- There will be marginal noise exceedances of ICNG management levels at receivers around the site during the proposed Saturday extended construction hours. With the mitigation strategies presented in Section 12.7 being adopted, construction noise impacts will be well managed in accordance with the ICNG.
- Residential receivers around the site are unlikely to be exposed to vibration levels exceeding the relevant vibration management levels for amenity, and not likely to exceed the damage risk vibration limits. Accordingly, as required by the ICNG, mitigation of these impacts have been recommended.

It is concluded that with the implementation of the mitigation and ongoing assessment recommended in Section 7, construction noise and vibration emissions from the proposed development will be managed in accordance with the ICNG.

Please contact us should you have any further queries.

Yours faithfully,



Acoustic Logic Pty Ltd
PeiPei Feng
MAAS

APPENDIX A – CONSTRUCTION PLANT NOISE EMISSION LEVELS

NOISE DESCRIPTORS

Ambient noise constantly varies in level from moment to moment, so it is not possible to accurately determine prevailing noise conditions by measuring a single, instantaneous noise level.

To quantify ambient noise, a 15 minute measurement interval is typically utilised. Noise levels are monitored on a continuous basis over this period, and statistical and integrating techniques are used to characterise the noise being measured.

The principal measurement parameters are:

L_{eq} - represents the average noise energy during a measurement period. This parameter is derived by integrating the noise levels measured over the measurement period. L_{eq} is important in the assessment of noise impact as it closely corresponds with how humans perceive the loudness of steady state and quasi-steady state noise sources (such as traffic noise).

L₉₀ – This is commonly used as a measure of the background noise level as it represents the noise level heard in the quieter periods during the measurement interval. The L₉₀ parameter is used to set noise emission criteria for potentially intrusive noise sources since the disturbance caused by a noise source will depend on how audible it is above the pre-existing noise environment, particularly during quiet periods, as represented by the L₉₀ level.

L₁₀ is used in some guidelines to measure noise produced by an intrusive noise source since it represents the average of the loudest noise levels produced at the source. Typically, this is used to assess noise from licenced venues.

L_{max} is the highest noise level produced during a noise event, and is typically used to assess sleep arousal impacts from short term noise events during the night. It is also used to assess internal noise levels resulting from aircraft and railway ground vibration induced noise.

L₁ is sometimes used in place of L_{max} to represent a typical noise level from a number of high level, short term noise events.

CONSTRUCTION PLANT NOISE EMISSION LEVELS

The following table presents typical sound power levels for construction plant used in this assessment.

The following have been considered to establish typical plant A-weighted sound power levels:

- Transport for NSW Construction Noise and Vibration Strategy (April 2018).
- Previous measurements undertaken by Acoustic Logic.
- AS 2436-2010 "Guide to noise and vibration control on construction, demolition and maintenance sites (Appendix A).

The equipment sound power spectra are based on information in the DEFRA database, and when not available from that source, from manufacturer's data or from measured spectra taken by this office of similar machinery.

Items identified as having annoying characteristics have been penalised by adding 5dB to the levels in the Transport for NSW's noise data base.

The emission levels in the table assume that machinery operates continuously (i.e. 100% duty), which is not always be the case. For example, excavators may load trucks intermittently for 5 minutes in every 15-minute assessment period so their duty would be 33%. The duty correction used in the assessment is indicated in the table.

*Note: not all equipment may be relevant/assessed within this report. Refer to the relevant noise prediction sections within this report.

Table 14 – Construction and Civil works Machinery Effective Sound Power Levels based on Continuous operation (100% duty)

Equipment	Approx. Size/ Weight/Model	Sound Power Level (dBA) 100% Duty (inc Penalties)	Duty	Unweighted Octave Band Sound Power Levels, dB (includes Applicable Penalties)							
				63	125	250	500	1000	2000	4000	8000
Asphalt - Truck & Sprayer	-	106	100%	112	110	104	102	99	97	100	92
Backhoe	-	111	66%	113	107	103	111	104	103	98	94
Chainsaw – petrol*	4-5hp	114	50%	92	106	103	111	113	114	112	109
Compactor	-	106	100%	99	101	97	100	100	100	96	93
Compressor	-	109	25%	127	116	107	102	100	98	101	90
Crane - Fixed	-	113	50%	120	115	116	112	106	99	93	87
Crane - Franna	20 tonne	98	50%	108	104	99	91	92	91	84	78
Crane - Mobile	-	113	25%	115	114	108	109	108	108	99	90
Crane - Truck mounted	20 to 60 tonne	108	25%	112	109	107	105	103	100	95	87
Crusher – Rock*	-	118	100%	135	128	121	123	117	113	108	101
Dozer	CAT D9	116	75%	112	116	114	114	111	108	102	94
Dozer	CAT D10	121	75%	130	131	122	114	115	111	109	105
Elevated work platform - scissor lift	-	98	10%	100	97	94	94	94	91	85	83
Elevated work platform	-	97	10%	108	106	92	93	90	89	88	79
Excavator - tracked	3 tonne	90	75%	101	91	88	88	85	83	78	72
Excavator - tracked	6 tonne	95	75%	102	104	95	89	89	87	82	77
As above + hydraulic hammer*	6 tonne	115	75%	110	113	110	114	117	113	111	106
Excavator - tracked	10 tonne	100	100%	104	100	99	97	95	92	86	81
As above + hydraulic hammer*	10 tonne	118	75%	124	124	121	116	118	116	114	109
Excavator - tracked	20 tonne	105	75%	107	114	106	101	98	97	93	90
Excavator - tracked	30 tonne	110	75%	113	113	107	107	105	102	97	91
As above + hydraulic hammer*	-	122	75%	125	123	119	123	121	121	118	114
Excavator - tracked	40 tonne	115	75%	111	114	113	110	110	109	104	97
Grader	-	113	100%	114	113	109	105	110	104	100	91
Generator - diesel/petrol	6kW	103	100%	115	110	102	98	97	95	92	80

Generator - attenuated	30kW	92	100%	95	95	93	86	85	86	82	79
Grinder*	-	105	50%	86	80	81	89	99	106	102	102
Jackhammer	-	113	75%	108	97	93	96	96	101	109	110
Lighting Tower	-	80	100%	73	73	73	73	73	73	73	73
Lighting - Daymakers	-	98	100%	110	105	97	93	92	90	87	75
Light Vehicle - 4WD	-	103	10%	96	96	96	96	96	96	96	96
Line Marking Truck	-	108	100%	114	112	106	104	101	99	102	94
Loader - Front-end (wheeled)	23 tonne	112	75%	118	118	107	109	105	103	102	94
Loader - Skidsteer	1/2 tonne	107	75%	112	115	104	106	101	98	92	92
Loaders - Skidsteer	1 tonne	110	75%	113	104	108	108	104	103	97	91
Loader - Tracked	0 to 50 kW	115	75%	108	108	108	108	108	108	108	108
Loaders- Tracked	200 to 300 kW	121	75%	114	114	114	114	114	114	114	114
Pavement Laying Machine	-	114	100%	117	114	111	110	109	106	104	95
Pavement Profiler	-	117	100%	116	122	114	112	112	109	105	102
Pile Driver – Vibratory*	-	121	50%	121	120	117	120	122	120	115	105
Piling Rig - Bored	-	112	100%	112	120	109	108	106	104	96	89
Piling Rig Lmax – Impact*	-	151	n/a	137	138	143	152	152	148	143	138
Piling Rig Leq- Impact*	-	134	100%	124	125	128	135	135	132	127	121
Pump - Concrete	-	109	100%	115	107	101	102	104	104	97	89
Rattle gun (hand held)	-	104	50%	82	81	81	87	96	98	98	98
Roller - smooth drum	-	107	100%	114	112	102	100	102	100	96	90
Roller - large pad foot	-	109	100%	120	111	103	107	105	98	95	89
Roller – Vibratory*	10 tonne	109	100%	125	116	108	112	110	103	100	94
Saw – Concrete*	-	118	75%	120	122	114	114	113	114	118	116
Scraper/Grader	-	113	100%	120	122	113	107	107	105	100	95
Truck - Concrete	-	109	100%	112	103	95	98	99	107	89	84
Truck - Dump	15 tonne	110	10%	114	111	111	107	104	103	97	90
Truck - Medium rigid	20 tonne	103	10%	109	107	101	99	96	94	97	89
Truck - road truck/ truck and dog	30 tonne	108	10%	123	109	101	100	104	99	98	91
Truck - Vacuum (NDD or non-destructive digger)	-	109	75%	111	112	97	102	101	104	103	96

Tub Grinder/Mulcher	40-50hp	116	100%	105	106	110	110	112	111	105	96
Vibrator – Concrete*	-	113	100%	122	120	120	113	109	112	110	105
Water Cart	-	107	100%	106	107	101	105	99	100	96	91
Welding equipment	-	110	50%	104	105	106	105	106	103	98	93
Wrench - Impact	-	111	50%	81	84	89	91	95	101	107	107