

DEPOSITED PLAN ADMINISTRATION SHEET

<p style="text-align: right; font-size: small;">Office Use Only</p> <p>Registered: Title System: Purpose:</p>	<p style="text-align: right; font-size: small;">Office Use Only</p> <p style="text-align: center; font-size: 24pt; font-weight: bold;">DRAFT</p> <p style="text-align: center; font-weight: bold;">PRINTED 18 NOV 2016 ISSUE 14 STAGE 4</p>
<p>PLAN OF SUBDIVISION OF LOT 200 & 201 IN D.P. 1212253 AND LOT 1 IN D.P. 807298</p>	<p>LGA: SYDNEY Locality: CHIPPENDALE Parish: ALEXANDRIA County: CUMBERLAND</p>
<p style="text-align: center;">Crown Lands NSW/Western Lands Office Approval</p> <p>I..... (Authorised Officer) in approving this plan certify that all necessary approvals in regard to the allocation of the land shown herein have been given</p> <p>Signature: Date: File Number: Office:</p>	<p style="text-align: center;">Surveying Certificate</p> <p>I, TASY MORAITIS..... of Linker Surveying Pty Ltd Suite 301 Level 3 55 Holt St Surry Hills NSW 2010 a surveyor registered under the <i>Surveying and Spatial Information Act 2002</i>, certify that</p> <p>*(a) The land shown in the plan was surveyed in accordance with the Surveying and Spatial Information Regulation, 2012, is accurate and the survey was completed on:</p> <p>*(b) The part of the land shown in the plan (being/*excluding^.....) was surveyed in accordance with the Surveying and Spatial Information Regulation 2012, is accurate and the survey was completed on, the part not surveyed was compiled in accordance with that Regulation.</p> <p>*(c) The land shown in this plan was compiled in accordance with the Surveying and Spatial Information Regulation 2012.</p> <p>Signature: Dated: Surveyor ID: Datum Line: Type: *Urban/*Rural The terrain is *Level-Undulating / *Steep-Mountainous. *Strike through if inapplicable. ^Specify the land actually surveyed or specify any land shown in the plan that is not the subject of the survey.</p>
<p style="text-align: center;">Subdivision Certificate</p> <p>I..... *Authorised Person/*General Manager/*accredited Certifier, certify that the provisions of s.109J of the Environmental Planning and Assessment Act 1979 have been satisfied in relation to the proposed subdivision, new road or reserve set out herein.</p> <p>Signature: Accreditation no: Consent/Authority: Date of Endorsement: Subdivision Certificate no: File no:</p> <p style="text-align: center;">*Strike through if inapplicable</p>	<p>Plans used in the preparation of survey/compilation</p> <p style="text-align: right;">If space is insufficient continue on PLAN FORM 6A</p>
<p>STATEMENTS of intention to dedicate public roads, public reserves and drainage easements</p>	<p>SURVEYORS REFERENCE: 080401 SL2 SUB</p>
<p>Signatures, Seals and Section 88B Statements should appear on PLAN FORM 6A</p>	<p>PLAN FORM 6A</p>

DEPOSITED PLAN ADMINISTRATION SHEET

Office Use Only	<p>DRAFT</p> <p>PRINTED 18 NOV 2016</p> <p>ISSUE 14</p> <p>STAGE 4</p>	Office Use Only
Registered:	<p>This sheet is for the provision of the following information as required:</p> <ul style="list-style-type: none"> • A schedule of lots and addresses - See 60(c) SSI Regulation 2012 • Statements of intention to create and release affecting interests in accordance with section 88B Conveyancing Act 1919 • Signatures and seals - see 195D Conveyancing Act 1919 • Any information which cannot fit in the appropriate panel of sheet 1 of the administration sheets. 	
PLAN OF SUBDIVISION OF LOT 200 & 201 IN D.P. 1212253 AND LOT 1 IN D.P. 807298		
Subdivision Certificate No:		
Date of Endorsement:		

PURSUANT TO SECTION 88B OF THE CONVEYANCING ACT 1919 AND SECTION 7(3) OF THE STRATA SCHEMES (FREEHOLD DEVELOPMENT) ACT 1973, IT IS INTENDED TO CREATE:

- 1) EASEMENT FOR SUPPORT AND SHELTER (AA) – (WHOLE OF LOT)
- 2) EASEMENT FOR SERVICES (BB) – (WHOLE OF LOT)
- 3) EASEMENT TO USE FIRE STAIRS, PASSAGES AND EMERGENCY EQUIPMENT (CC) (WHOLE OF LOT)
- 4) EASEMENT TO ACCESS AND USE FACILITIES (DD) (WHOLE OF LOT)
- 5) EASEMENT FOR CENTRAL THERMAL PLANT RETICULATION AND SERVICE INFRASTRUCTURE (3V1) VARIABLE WIDTH (LIMITED IN STRATUM)
- 6) EASEMENT FOR COLLECTION AND PASSAGE OF STORMWATER (3T) VARIABLE WIDTH (LIMITED IN STRATUM)
- 7) EASEMENT FOR RECYCLED WATER PLANT SEWAGE RETICULATION SERVICE INFRASTRUCTURE (3T1) VARIABLE WIDTH (LIMITED IN STRATUM)
- 8) EASEMENT FOR RECYCLED WATER PLANT RECYCLED WATER RETICULATION SERVICE INFRASTRUCTURE (3T2) VARIABLE WIDTH (LIMITED IN STRATUM)
- 9) EASEMENT FOR POTABLE COLD WATER SERVICE (3T3) VARIABLE WIDTH (LIMITED IN STRATUM)
- 10) EASEMENT FOR MAINTENANCE & REPAIR OF SEWER MINING PITS (3AA) VARIABLE WIDTH (LIMITED IN STRATUM)
- 11) EASEMENT FOR THE PASSAGE OF WTP SERVICES (3T4)
- 12) EASEMENT TO ACCESS AND MAINTAIN CTP TOWER INFRASTRUCTURE (3A)
- 13) EASEMENT TO ACCESS BREWERY YARD FOR MAINTENANCE AND REPAIR (3C) VARIABLE WIDTH (LIMITED IN STRATUM)
- 14) RESTRICTION ON USE
- 15) EASEMENT FOR CTP ACCESS (3D) VARIABLE WIDTH (LIMITED IN STRATUM)
- 16) EASEMENT TO ACCESS AND SERVICE FIRE SERVICES (3F) (LIMITED IN STRATUM)
- 17) EASEMENT FOR PERMANENT ART INSTALLATION (3G) VARIABLE WIDTH (LIMITED IN STRATUM)
- 18) EASEMENT FOR PUBLIC PEDESTRIAN ACCESS (3H) VARIABLE WIDTH (LIMITED IN STRATUM)
- 19) EASEMENT FOR AUSGRID ACCESS (3K) VARIABLE WIDTH (LIMITED IN STRATUM)

NOTE – THE POSITION OF THE EASEMENTS TO BE ADDED TO THE DRAFT STRATUM PLAN AS THE PROJECT DEVELOPS.

If space is insufficient use additional annexure sheet

SURVEYORS REFERENCE: 080401 SL2 SUB

DEPOSITED PLAN ADMINISTRATION SHEET

Office Use Only Registered: PLAN OF SUBDIVISION OF LOT 200 & 201 IN D.P. 1212253 AND LOT 1 IN D.P. 807298	Office Use Only <h1 style="margin: 0;">DRAFT</h1> <h2 style="margin: 0;">PRINTED 18 NOV 2016</h2> <h3 style="margin: 0;">ISSUE 14</h3> <h3 style="margin: 0;">STAGE 4</h3>
Subdivision Certificate No: Date of Endorsement:	This sheet is for the provision of the following information as required: <ul style="list-style-type: none"> A schedule of lots and addresses - See 60(c) SSI Regulation 2012 Statements of intention to create and release affecting interests in accordance with section 88B Conveyancing Act 1919 Signatures and seals - see 195D Conveyancing Act 1919 Any information which cannot fit in the appropriate panel of sheet 1 of the administration sheets.

PURSUANT TO SECTION 88B OF THE CONVEYANCING ACT 1919 AND SECTION 7(3) OF THE STRATA SCHEMES (FREEHOLD DEVELOPMENT) ACT 1973, IT IS INTENDED TO CREATE:

- 20) EASEMENT TO ACCESS VARIABLE WIDTH (A) (LIMITED IN STRATUM)
- 21) EASEMENT TO ACCESS AND USE LIFTS VARIABLE WIDTH (B) (LIMITED IN STRATUM)
- 22) EASEMENT FOR ACCESS BY FOOT VARIABLE WIDTH (D) (LIMITED IN STRATUM)
- 23) EASEMENT TO ACCESS AND USE LIFTS VARIABLE WIDTH (E) (LIMITED IN STRATUM)
- 24) EASEMENT TO ACCESS AND USE LOADING DOCK VARIABLE WIDTH (F) (LIMITED IN STRATUM)
- 25) EASEMENT TO ACCESS AND USE LOADING DOCK VARIABLE WIDTH (G) (LIMITED IN STRATUM)
- 26) EASEMENT TO ACCESS AND USE GARBAGE ROOM VARIABLE WIDTH (H) (LIMITED IN STRATUM)
- 27) EASEMENT TO ACCESS AND USE GARBAGE ROOM VARIABLE WIDTH (J) (LIMITED IN STRATUM)
- 28) EASEMENT TO ACCESS AND USE CAR SHARE PARKING SPACES VARIABLE WIDTH (K) (LIMITED IN STRATUM)
- 29) RESTRICTION ON THE USE OF LAND
- 30) RESTRICTION ON THE USE OF LAND
- 31) EASEMENT FOR VISITOR BICYCLE SPACES VARIABLE WIDTH (L) (LIMITED IN STRATUM)
- 32) EASEMENT FOR BICYCLE SPACES VARIABLE WIDTH (M) (LIMITED IN STRATUM)
- 33) EASEMENT FOR CTP STORAGE TANK VARIABLE WIDTH (N) (LIMITED IN STRATUM)
- 34) POSITIVE COVENANT
- 35) EASEMENT FOR PASSAGE OF CENTRAL THERMAL PLANT SERVICES VARIABLE WIDTH (3V1) (LIMITED IN STRATUM)
- 36) EASEMENT TO ACCESS AND USE GOODS LIFT VARIABLE WIDTH (P) (LIMITED IN STRATUM)
- 37) EASEMENT TO ACCESS AND USE GOODS LIFT VARIABLE WIDTH (Q) (LIMITED IN STRATUM)
- 38) EASEMENT FOR PUBLIC ACCESS VARIABLE WIDTH (R) (LIMITED IN STRATUM)
- 39) EASEMENT FOR CTP ACCESS PURPOSES VARIABLE WIDTH (S) LIMITED IN STRATUM)
- 40) EASEMENT FOR WTP SERVICES VARIABLE WIDTH (T) (LIMITED IN STRATUM)
- 41) EASEMENT FOR CTP SERVICES VARIABLE WIDTH (V) (LIMITED IN STRATUM)
- 42) EASEMENT FOR ACCESS OVER FUTURE ROAD VARIABLE WIDTH (W) (LIMITED IN STRATUM)
- 43) EASEMENT FOR SERVICES WITHIN FUTURE ROAD VARIABLE WIDTH (X) (LIMITED IN STRATUM)
- 44) EASEMENT FOR SUPPORT OF ROAD VARIABLE WIDTH (Y) (LIMITED IN STRATUM)
- 45) POSITIVE COVENANT FOR SUPPORT OF ROAD
- 46) EASEMENT FOR GREASE ARRESTOR ROOM VARIABLE WIDTH (Z) (LIMITED IN STRATUM)
- 47) EASEMENT FOR ACCESS VARIABLE WIDTH (AA) (LIMITED IN STRATUM)
- 48) EASEMENT FOR ROOF ACCESS VARIABLE WIDTH (AB) (LIMITED IN STRATUM)
- 49) EASEMENT FOR KITCHEN EXHAUST PURPOSES VARIABLE WIDTH (AC) (LIMITED IN STRATUM)
- 50) EASEMENT FOR END OF TRIP FACILITIES VARIABLE WIDTH (AD)(LIMITED IN STRATUM)

NOTE – THE POSITION OF THE EASEMENTS TO BE ADDED TO THE DRAFT STRATUM PLAN AS THE PROJECT DEVELOPS.

If space is insufficient use additional annexure sheet

SURVEYORS REFERENCE: 080401 SL2 SUB

BASEMENT LEVEL 4

BROADWAY

CHIPPENDALE WAY

STREET

ABERCROMBIE

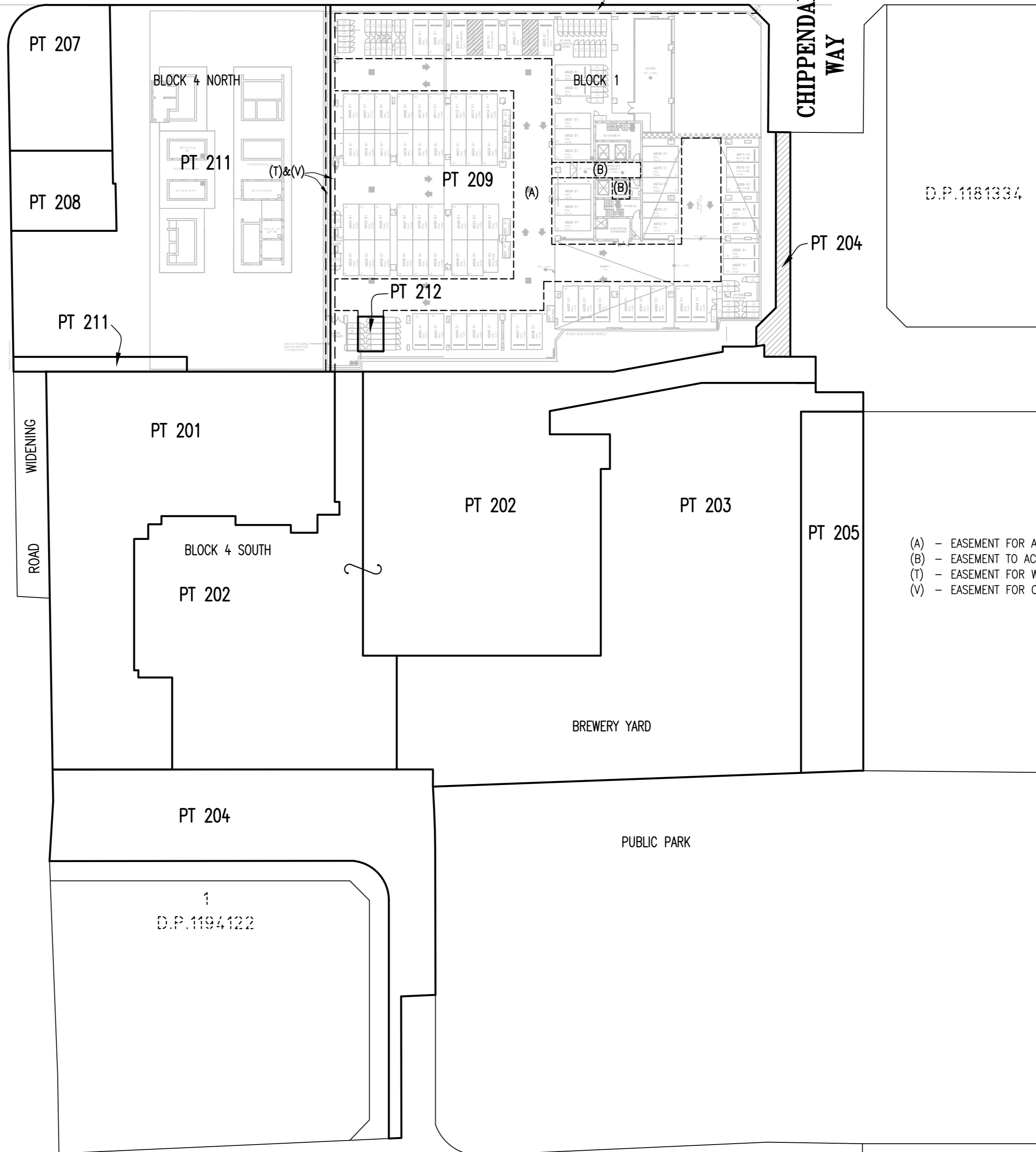

- (A) - EASEMENT FOR ACCESS VARIABLE WIDTH (LIMITED IN STRATUM)
- (B) - EASEMENT TO ACCESS AND USE LIFTS VARIABLE WIDTH (LIMITED IN STRATUM)
- (T) - EASEMENT FOR WTP SERVICES VARIABLE WIDTH (LIMITED IN STRATUM)
- (V) - EASEMENT FOR CTP SERVICES VARIABLE WIDTH (LIMITED IN STRATUM)

WHOLE OF LOT EASEMENTS AFFECTING LOTS 201, 202, 203, 206, 209, 210, 211, 212, 213, 214 & 215

- EASEMENT FOR SUPPORT AND SHELTER
- EASEMENT TO SERVICES
- EASEMENT FOR FIRE STAIRS & PASSAGES
- EASEMENT TO ACCESS FACILITIES

SCHEDULE OF STRATUM LOTS WITHIN STAGES 1 & 2

STAGE 1 LOTS

- LOT 201 - BLOCK 4S STUDENT ACCOMMODATION STRATUM LOT
- LOT 202 - CENTRAL THERMAL PLANT (CTP) STAGE 2 STRATUM LOT.
- LOT 203 - BREWERY YARD STRATUM LOT
- LOT 204 - PUBLIC ROAD STRATUM LOT
- LOT 205 - OPEN SPACE STRATUM LOT
- LOT 206 - BLOCK 4S RETAIL STRATUM LOT
- LOT 207 - 'PUB' STRATUM LOT
- LOT 208 - 'TERRACE' STRATUM LOT
- LOT 209 - BLOCK 1 RESIDENTIAL STRATUM LOT
- LOT 210 - BLOCK 1 RETAIL STRATUM LOT
- LOT 211 - BLOCK 4N HOTEL STRATUM LOT
- LOT 212 - BLOCK 4N COMMERCIAL STRATUM LOT
- LOT 213 - BLOCK 4N CHILDCARE STRATUM LOT
- LOT 214 - BREWERY YARD PARKING STRATUM LOT
- LOT 215 - BLOCK 4N RESIDENTIAL STRATUM LOT

Surveyor: TASY MORAITIS
 Date of Survey:
 Surveyor's Ref: 080401 SL2 SUB

PLAN OF SUBDIVISION OF LOT 200 & 201 IN
 D.P. 1212253 AND LOT 1 IN D.P. 807298

SUBDIVISION OF BLOCK 1, BLOCK 1 NORTH,
 BLOCK 4 SOUTH AND
 BREWERY YARD IN 2 STAGES

LGA: SYDNEY
 Locality: CHIPPENDALE
 Subdivision No:
 Lengths are in metres. Reduction Ratio 1: 500

REGISTERED
 CONTRACT PLAN
 Plan compiled from
 architectural CAD data.
 Plan is subject to final
 survey after completion
 of construction.

DRAFT
 PRINTED 18 NOV 2016
 ISSUE 14
 STAGE 4

BASEMENT LEVEL 3

BROADWAY

CHIPPENDALE WAY

STREET

ABERCROMBIE

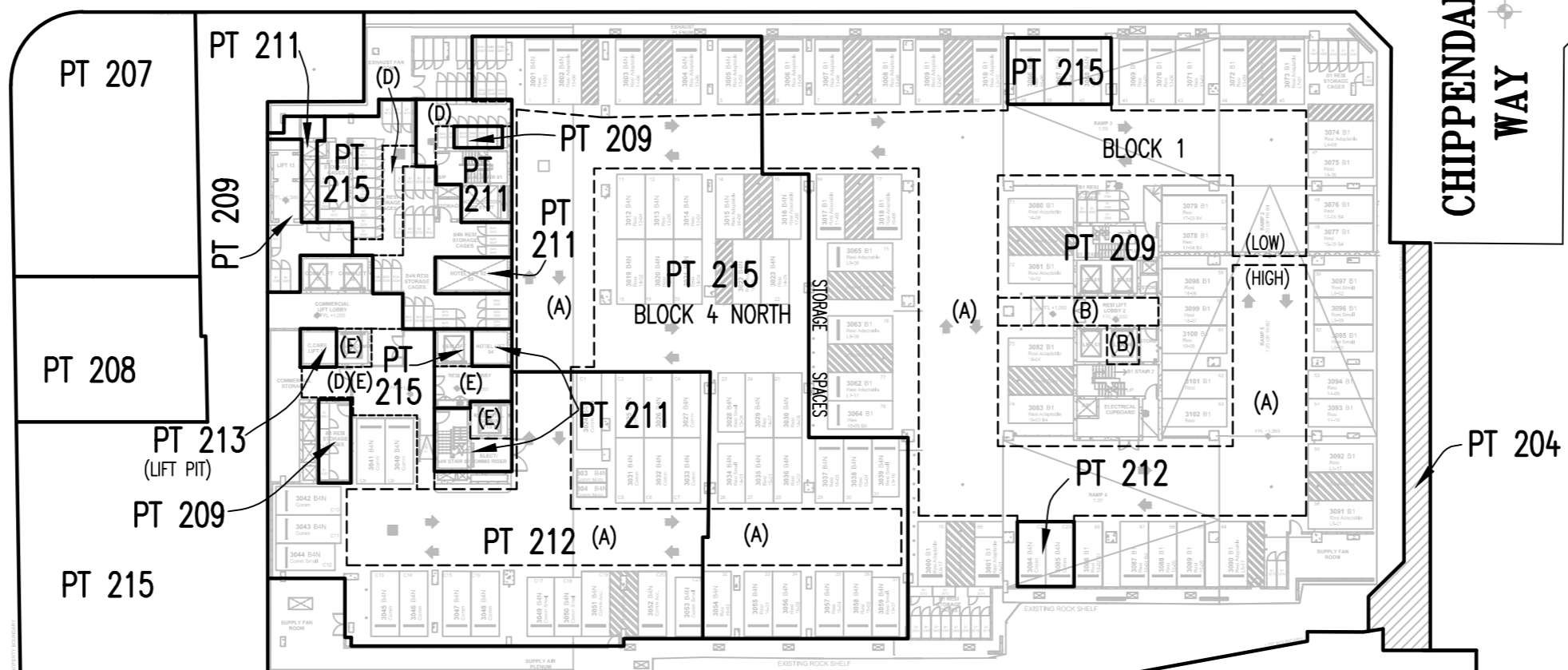

D.P.1181334

- (A) - EASEMENT FOR ACCESS VARIABLE WIDTH (LIMITED IN STRATUM)
- (B) - EASEMENT TO ACCESS AND USE LIFTS VARIABLE WIDTH (LIMITED IN STRATUM)
- (D) - EASEMENT FOR ACCESS BY FOOT VARIABLE WIDTH (LIMITED IN STRATUM)
- (E) - EASEMENT TO ACCESS AND USE LIFTS VARIABLE WIDTH (LIMITED IN STRATUM)

WHOLE OF LOT EASEMENTS AFFECTING LOTS 201, 202, 203, 206, 209, 210, 211, 212, 213, 214 & 215

- EASEMENT FOR SUPPORT AND SHELTER
- EASEMENT TO SERVICES
- EASEMENT FOR FIRE STAIRS & PASSAGES
- EASEMENT TO ACCESS FACILITIES

SCHEDULE OF STRATUM LOTS WITHIN STAGES 1 & 2

STAGE 1 LOTS

- LOT 201 - BLOCK 4S STUDENT ACCOMMODATION STRATUM LOT
- LOT 202 - CENTRAL THERMAL PLANT (CTP) STAGE 2 STRATUM LOT.
- LOT 203 - BREWERY YARD STRATUM LOT
- LOT 204 - PUBLIC ROAD STRATUM LOT
- LOT 205 - OPEN SPACE STRATUM LOT
- LOT 206 - BLOCK 4S RETAIL STRATUM LOT
- LOT 207 - 'PUB' STRATUM LOT
- LOT 208 - 'TERRACE' STRATUM LOT
- LOT 209 - BLOCK 1 RESIDENTIAL STRATUM LOT
- LOT 210 - BLOCK 1 RETAIL STRATUM LOT
- LOT 211 - BLOCK 4N HOTEL STRATUM LOT
- LOT 212 - BLOCK 4N COMMERCIAL STRATUM LOT
- LOT 213 - BLOCK 4N CHILDCARE STRATUM LOT
- LOT 214 - BREWERY YARD PARKING STRATUM LOT
- LOT 215 - BLOCK 4N RESIDENTIAL STRATUM LOT

WIDENING

ROAD

PT 201

PT 202

PT 203

PT 205

BLOCK 4 SOUTH

PT 202

BREWERY YARD

PT 204

PUBLIC PARK

1
D.P.1194122

Surveyor: TASY MORAITIS
 Date of Survey:
 Surveyor's Ref: 080401 SL2 SUB

PLAN OF SUBDIVISION OF LOT 200 & 201 IN
 D.P. 1212253 AND LOT 1 IN D.P. 807298

SUBDIVISION OF BLOCK 1, BLOCK 1 NORTH,
 BLOCK 4 SOUTH AND
 BREWERY YARD IN 2 STAGES

LGA: SYDNEY
 Locality: CHIPPENDALE
 Subdivision No:
 Lengths are in metres. Reduction Ratio 1:500

REGISTERED
 CONTRACT PLAN
 Plan compiled from
 architectural CAD data.
 Plan is subject to final
 survey after completion
 of construction.

DRAFT
 PRINTED 18 NOV 2016
 ISSUE 14
 STAGE 4

BASEMENT LEVEL 2



STREET

ABERCROMBIE

BROADWAY

CHIPPENDALE WAY

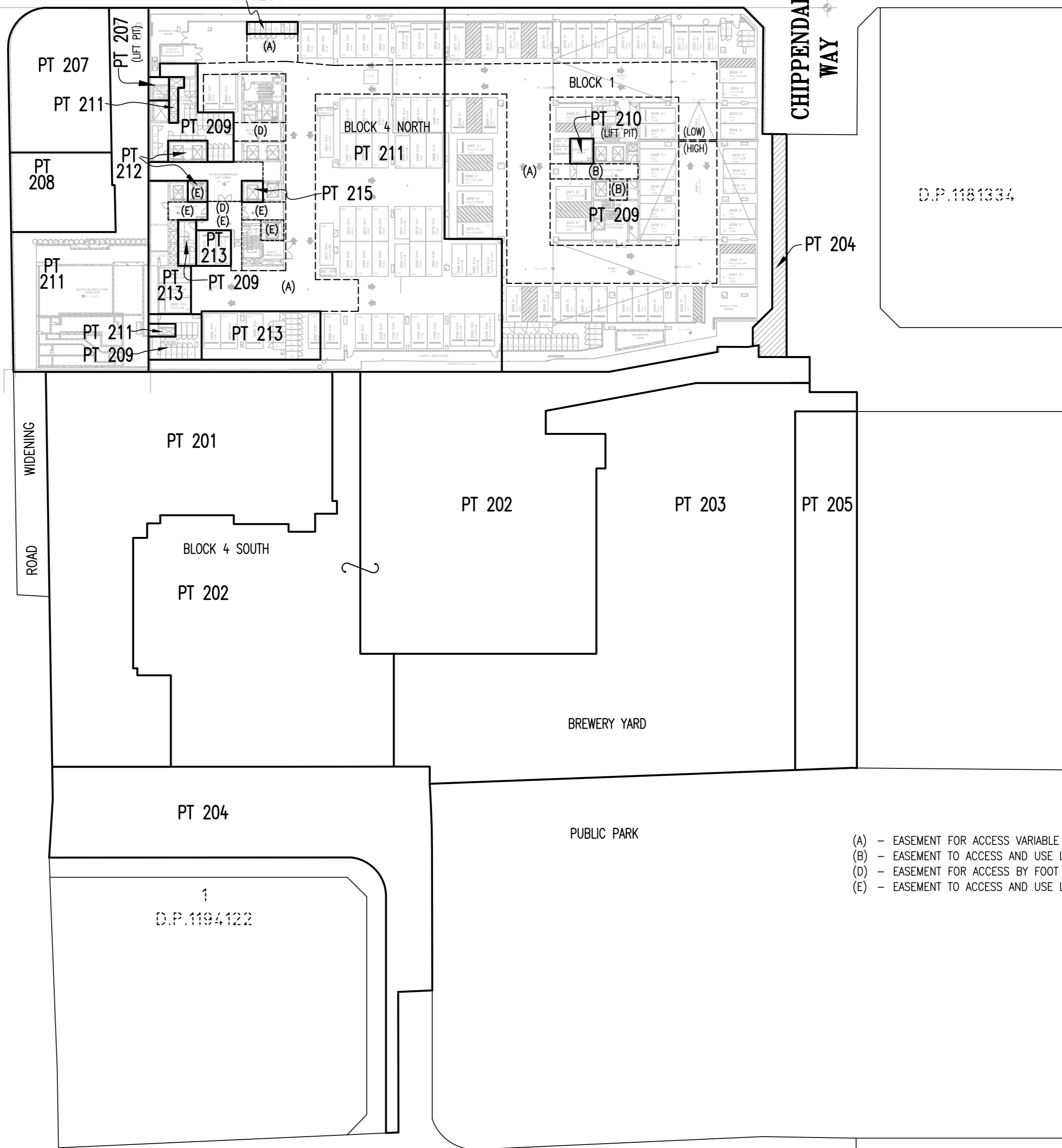

D.P.1181334

D.P.1194122

WHOLE OF LOT EASEMENTS AFFECTING LOTS 201, 202, 203, 206, 209, 210, 211, 212, 213, 214 & 215

- EASEMENT FOR SUPPORT AND SHELTER
- EASEMENT TO SERVICES
- EASEMENT FOR FIRE STAIRS & PASSAGES
- EASEMENT TO ACCESS FACILITIES

- (A) - EASEMENT FOR ACCESS VARIABLE WIDTH (LIMITED IN STRATUM)
- (B) - EASEMENT TO ACCESS AND USE LIFTS VARIABLE WIDTH (LIMITED IN STRATUM)
- (D) - EASEMENT FOR ACCESS BY FOOT VARIABLE WIDTH (LIMITED IN STRATUM)
- (E) - EASEMENT TO ACCESS AND USE LIFTS VARIABLE WIDTH (LIMITED IN STRATUM)

SCHEDULE OF STRATUM LOTS WITHIN STAGES 1 & 2

STAGE 1 LOTS

- LOT 201 - BLOCK 4S STUDENT ACCOMMODATION STRATUM LOT
- LOT 202 - CENTRAL THERMAL PLANT (CTP) STAGE 2 STRATUM LOT.
- LOT 203 - BREWERY YARD STRATUM LOT
- LOT 204 - PUBLIC ROAD STRATUM LOT
- LOT 205 - OPEN SPACE STRATUM LOT
- LOT 206 - BLOCK 4S RETAIL STRATUM LOT
- LOT 207 - 'PUB' STRATUM LOT
- LOT 208 - 'TERRACE' STRATUM LOT
- LOT 209 - BLOCK 1 RESIDENTIAL STRATUM LOT
- LOT 210 - BLOCK 1 RETAIL STRATUM LOT
- LOT 211 - BLOCK 4N HOTEL STRATUM LOT
- LOT 212 - BLOCK 4N COMMERCIAL STRATUM LOT
- LOT 213 - BLOCK 4N CHILDCARE STRATUM LOT
- LOT 214 - BREWERY YARD PARKING STRATUM LOT
- LOT 215 - BLOCK 4N RESIDENTIAL STRATUM LOT

Surveyor: TASY MORAITIS
 Date of Survey:
 Surveyor's Ref: 080401 SL2 SUB

PLAN OF SUBDIVISION OF LOT 200 & 201 IN
 D.P. 1212253 AND LOT 1 IN D.P. 807298

SUBDIVISION OF BLOCK 1, BLOCK 1 NORTH,
 BLOCK 4 SOUTH AND
 BREWERY YARD IN 2 STAGES

LGA: SYDNEY
 Locality: CHIPPENDALE
 Subdivision No:
 Lengths are in metres. Reduction Ratio 1:500

REGISTERED
 CONTRACT PLAN
 Plan compiled from
 architectural CAD data.
 Plan is subject to final
 survey after completion
 of construction.

DRAFT
 PRINTED 18 NOV 2016
 ISSUE 14
 STAGE 4

BASEMENT LEVEL 1

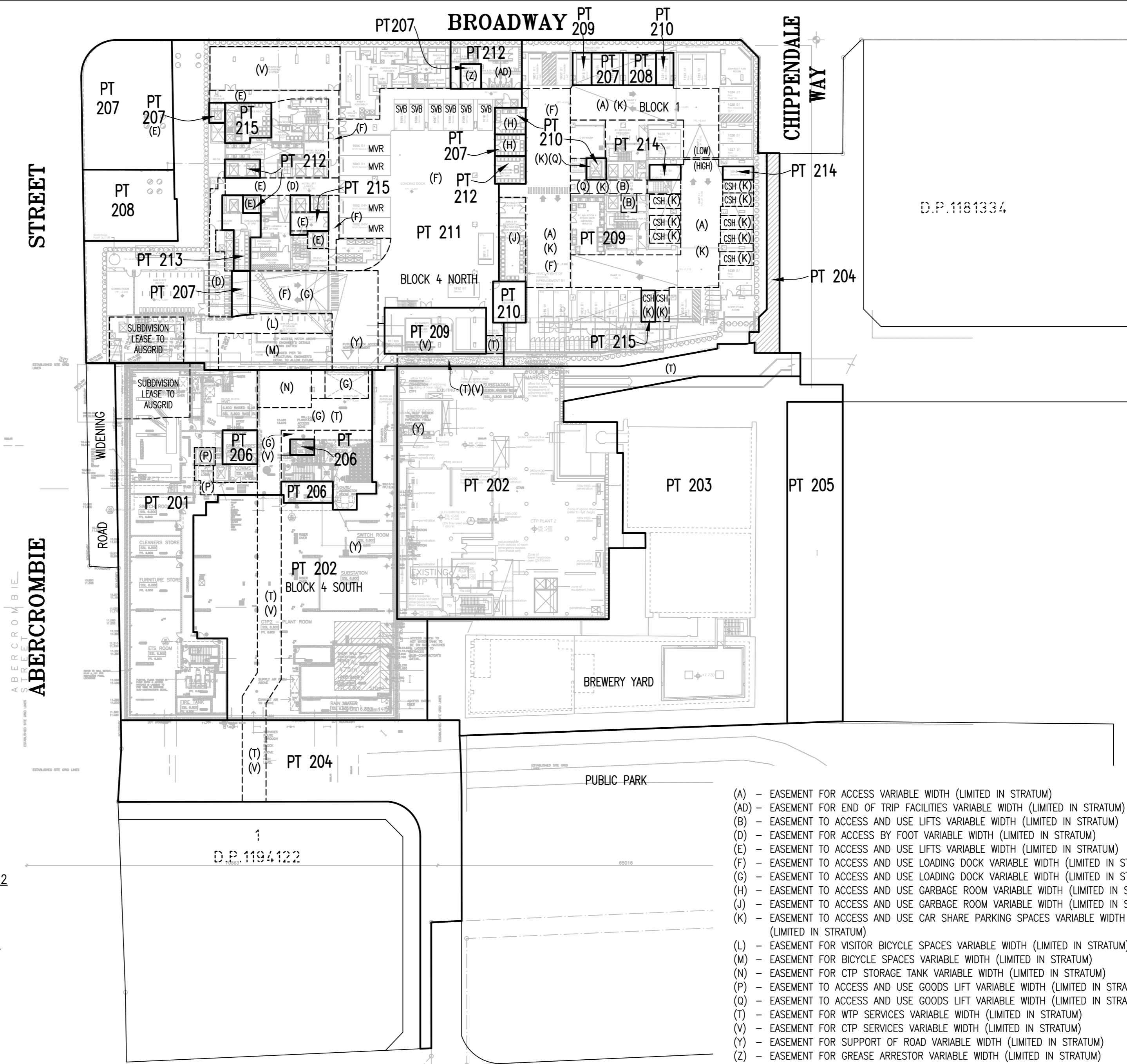

CSH - DENOTES CAR SHARE SPACE
MVR - DENOTES SERVICE TRUCK BAY
SVB - DENOTES SERVICE VEHICLE BAY

- WHOLE OF LOT EASEMENTS AFFECTING LOTS 201, 202, 203, 206, 209, 210, 211, 212, 213, 214 & 215
- EASEMENT FOR SUPPORT AND SHELTER
 - EASEMENT TO SERVICES
 - EASEMENT FOR FIRE STAIRS & PASSAGES
 - EASEMENT TO ACCESS FACILITIES

SCHEDULE OF STRATUM LOTS WITHIN STAGES 1 & 2

STAGE 1 LOTS

- LOT 201 - BLOCK 4S STUDENT ACCOMMODATION STRATUM LOT
- LOT 202 - CENTRAL THERMAL PLANT (CTP) STAGE 2 STRATUM LOT.
- LOT 203 - BREWERY YARD STRATUM LOT
- LOT 204 - PUBLIC ROAD STRATUM LOT
- LOT 205 - OPEN SPACE STRATUM LOT
- LOT 206 - BLOCK 4S RETAIL STRATUM LOT
- LOT 207 - 'PUB' STRATUM LOT
- LOT 208 - 'TERRACE' STRATUM LOT
- LOT 209 - BLOCK 1 RESIDENTIAL STRATUM LOT
- LOT 210 - BLOCK 1 RETAIL STRATUM LOT
- LOT 211 - BLOCK 4N HOTEL STRATUM LOT
- LOT 212 - BLOCK 4N COMMERCIAL STRATUM LOT
- LOT 213 - BLOCK 4N CHILDCARE STRATUM LOT
- LOT 214 - BREWERY YARD PARKING STRATUM LOT
- LOT 215 - BLOCK 4N RESIDENTIAL STRATUM LOT

- (A) - EASEMENT FOR ACCESS VARIABLE WIDTH (LIMITED IN STRATUM)
- (AD) - EASEMENT FOR END OF TRIP FACILITIES VARIABLE WIDTH (LIMITED IN STRATUM)
- (B) - EASEMENT TO ACCESS AND USE LIFTS VARIABLE WIDTH (LIMITED IN STRATUM)
- (D) - EASEMENT FOR ACCESS BY FOOT VARIABLE WIDTH (LIMITED IN STRATUM)
- (E) - EASEMENT TO ACCESS AND USE LIFTS VARIABLE WIDTH (LIMITED IN STRATUM)
- (F) - EASEMENT TO ACCESS AND USE LOADING DOCK VARIABLE WIDTH (LIMITED IN STRATUM)
- (G) - EASEMENT TO ACCESS AND USE LOADING DOCK VARIABLE WIDTH (LIMITED IN STRATUM)
- (H) - EASEMENT TO ACCESS AND USE GARBAGE ROOM VARIABLE WIDTH (LIMITED IN STRATUM)
- (J) - EASEMENT TO ACCESS AND USE GARBAGE ROOM VARIABLE WIDTH (LIMITED IN STRATUM)
- (K) - EASEMENT TO ACCESS AND USE CAR SHARE PARKING SPACES VARIABLE WIDTH (LIMITED IN STRATUM)
- (L) - EASEMENT FOR VISITOR BICYCLE SPACES VARIABLE WIDTH (LIMITED IN STRATUM)
- (M) - EASEMENT FOR BICYCLE SPACES VARIABLE WIDTH (LIMITED IN STRATUM)
- (N) - EASEMENT FOR CTP STORAGE TANK VARIABLE WIDTH (LIMITED IN STRATUM)
- (P) - EASEMENT TO ACCESS AND USE GOODS LIFT VARIABLE WIDTH (LIMITED IN STRATUM)
- (Q) - EASEMENT TO ACCESS AND USE GOODS LIFT VARIABLE WIDTH (LIMITED IN STRATUM)
- (T) - EASEMENT FOR WTP SERVICES VARIABLE WIDTH (LIMITED IN STRATUM)
- (V) - EASEMENT FOR CTP SERVICES VARIABLE WIDTH (LIMITED IN STRATUM)
- (Y) - EASEMENT FOR SUPPORT OF ROAD VARIABLE WIDTH (LIMITED IN STRATUM)
- (Z) - EASEMENT FOR GREASE ARRESTOR VARIABLE WIDTH (LIMITED IN STRATUM)

Surveyor: TASY MORAITIS
Date of Survey:
Surveyor's Ref: 080401 SL2 SUB

PLAN OF SUBDIVISION OF LOT 200 & 201 IN
D.P. 1212253 AND LOT 1 IN D.P. 807298
SUBDIVISION OF BLOCK 1, BLOCK 1 NORTH,
BLOCK 4 SOUTH AND
BREWERY YARD IN 2 STAGES

LGA: SYDNEY
Locality: CHIPPENDALE
Subdivision No:
Lengths are in metres. Reduction Ratio 1: 500

REGISTERED
CONTRACT PLAN
Plan compiled from
architectural CAD data.
Plan is subject to final
survey after completion
of construction.

DRAFT
PRINTED 18 NOV 2016
ISSUE 14
STAGE 4

**BASEMENT LEVEL 00
BLOCK 4S LOWER GROUND LEVEL**

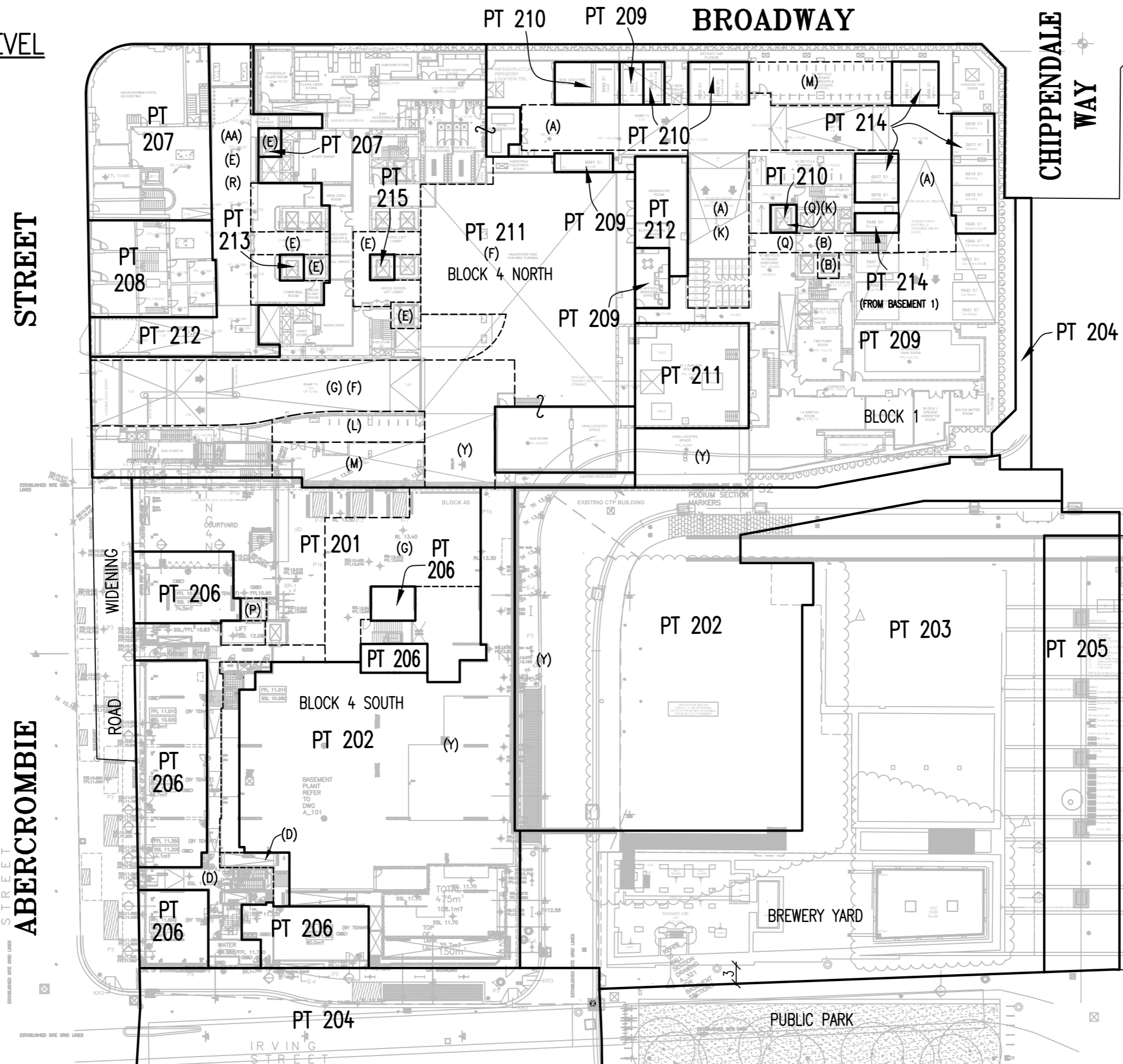

D.P.1181334

CSH - DENOTES CAR SHARE SPACE

- WHOLE OF LOT EASEMENTS AFFECTING LOTS 201, 202, 203, 206, 209, 210, 211, 212, 213, 214 & 215
- EASEMENT FOR SUPPORT AND SHELTER
 - EASEMENT TO SERVICES
 - EASEMENT FOR FIRE STAIRS & PASSAGES
 - EASEMENT TO ACCESS FACILITIES

- (A) - EASEMENT FOR ACCESS VARIABLE WIDTH (LIMITED IN STRATUM)
- (B) - EASEMENT TO ACCESS AND USE LIFTS VARIABLE WIDTH (LIMITED IN STRATUM)
- (D) - EASEMENT FOR ACCESS BY FOOT VARIABLE WIDTH (LIMITED IN STRATUM)
- (E) - EASEMENT TO ACCESS AND USE LIFTS VARIABLE WIDTH (LIMITED IN STRATUM)
- (F) - EASEMENT TO ACCESS AND USE LOADING DOCK VARIABLE WIDTH (LIMITED IN STRATUM)
- (G) - EASEMENT TO ACCESS AND USE LOADING DOCK VARIABLE WIDTH (LIMITED IN STRATUM)
- (K) - EASEMENT TO ACCESS AND USE CAR SHARE PARKING SPACES VARIABLE WIDTH (LIMITED IN STRATUM)
- (L) - EASEMENT FOR VISITOR BICYCLE SPACES VARIABLE WIDTH (LIMITED IN STRATUM)
- (M) - EASEMENT FOR BICYCLE SPACES VARIABLE WIDTH (LIMITED IN STRATUM)
- (P) - EASEMENT TO ACCESS AND USE GOODS LIFT VARIABLE WIDTH (LIMITED IN STRATUM)
- (Q) - EASEMENT TO ACCESS AND USE GOODS LIFT VARIABLE WIDTH (LIMITED IN STRATUM)
- (R) - EASEMENT FOR PUBLIC ACCESS VARIABLE WIDTH (LIMITED IN STRATUM)
- (Y) - EASEMENT FOR SUPPORT OF ROAD VARIABLE WIDTH (LIMITED IN STRATUM)
- (AA) - EASEMENT FOR ACCESS VARIABLE WIDTH (LIMITED IN STRATUM)

SCHEDULE OF STRATUM LOTS WITHIN STAGES 1 & 2

STAGE 1 LOTS

- LOT 201 - BLOCK 4S STUDENT ACCOMMODATION STRATUM LOT
- LOT 202 - CENTRAL THERMAL PLANT (CTP) STAGE 2 STRATUM LOT.
- LOT 203 - BREWERY YARD STRATUM LOT
- LOT 204 - PUBLIC ROAD STRATUM LOT
- LOT 205 - OPEN SPACE STRATUM LOT
- LOT 206 - BLOCK 4S RETAIL STRATUM LOT
- LOT 207 - 'PUB' STRATUM LOT
- LOT 208 - 'TERRACE' STRATUM LOT
- LOT 209 - BLOCK 1 RESIDENTIAL STRATUM LOT
- LOT 210 - BLOCK 1 RETAIL STRATUM LOT
- LOT 211 - BLOCK 4N HOTEL STRATUM LOT
- LOT 212 - BLOCK 4N COMMERCIAL STRATUM LOT
- LOT 213 - BLOCK 4N CHILDCARE STRATUM LOT
- LOT 214 - BREWERY YARD PARKING STRATUM LOT
- LOT 215 - BLOCK 4N RESIDENTIAL STRATUM LOT

Surveyor: TASY MORAITIS
 Date of Survey:
 Surveyor's Ref: 080401 SL2 SUB

PLAN OF SUBDIVISION OF LOT 200 & 201 IN
 D.P. 1212253 AND LOT 1 IN D.P. 807298
 SUBDIVISION OF BLOCK 1, BLOCK 1 NORTH,
 BLOCK 4 SOUTH AND
 BREWERY YARD IN 2 STAGES

LGA: SYDNEY
 Locality: CHIPPENDALE
 Subdivision No:
 Lengths are in metres. Reduction Ratio 1:500

REGISTERED
 CONTRACT PLAN
 Plan compiled from
 architectural CAD data.
 Plan is subject to final
 survey after completion
 of construction.

DRAFT
 PRINTED 18 NOV 2016
 ISSUE 14
 STAGE 4

GROUND LEVEL (LEVEL 00)

BROADWAY

CHIPPENDALE WAY

STREET

ABERCROMBIE

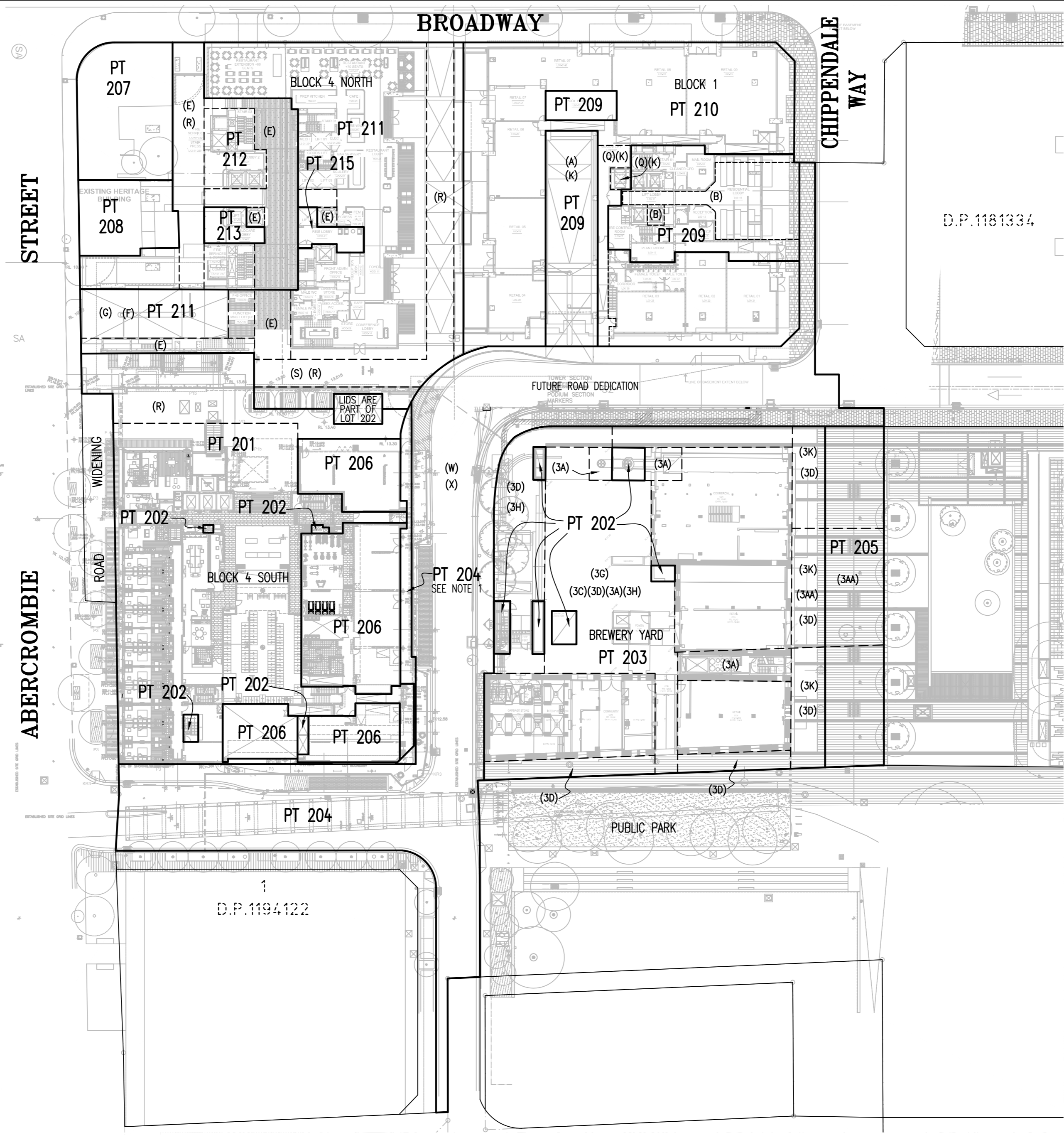

ALL THE EASEMENT NOTES BELOW ARE SUBJECT TO DEVELOPMENTS DESIGN AND FINAL SURVEY

PROPOSED EASEMENTS WITH RESPECT TO LOT 203

- (3A) - EASEMENT TO ACCESS AND MAINTAIN CTP TOWER INFRASTRUCTURE
- (3AA) - EASEMENT FOR MAINTENANCE AND REPAIR OF SEWER MINING PITS
- (3C) - EASEMENT TO ACCESS BREWERY YARD FOR MAINTENANCE AND REPAIR VARIABLE WIDTH
- (3D) - EASEMENT FOR CTP ACCESS VARIABLE WIDTH
- (3F) - EASEMENT TO ACCESS AND SERVICE FIRE SERVICES (SITE TO BE DETERMINED)
- (3G) - EASEMENT FOR TEMPORARY ART INSTALLATION VARIABLE WIDTH
- (3H) - EASEMENT FOR PUBLIC PEDESTRIAN ACCESS VARIABLE WIDTH
- (3K) - EASEMENT FOR AUSGRID ACCESS VARIABLE WIDTH
- (A) - EASEMENT FOR ACCESS VARIABLE WIDTH (LIMITED IN STRATUM)
- (B) - EASEMENT TO ACCESS AND USE LIFTS VARIABLE WIDTH (LIMITED IN STRATUM)
- (E) - EASEMENT TO ACCESS AND USE LIFTS VARIABLE WIDTH (LIMITED IN STRATUM)
- (F) - EASEMENT TO ACCESS AND USE LOADING DOCK VARIABLE WIDTH (LIMITED IN STRATUM)
- (G) - EASEMENT TO ACCESS AND USE LOADING DOCK VARIABLE WIDTH (LIMITED IN STRATUM)
- (K) - EASEMENT TO ACCESS AND USE CAR SHARE PARKING SPACES VARIABLE WIDTH (LIMITED IN STRATUM)
- (Q) - EASEMENT TO ACCESS AND USE GOODS LIFT VARIABLE WIDTH (LIMITED IN STRATUM)
- (R) - EASEMENT FOR PUBLIC ACCESS VARIABLE WIDTH (LIMITED IN STRATUM)
- (S) - EASEMENT FOR CTP ACCESS PURPOSES VARIABLE WIDTH (LIMITED IN STRATUM)
- (W) - EASEMENT FOR ACCESS OVER FUTURE ROAD VARIABLE WIDTH (LIMITED IN STRATUM)
- (X) - EASEMENT FOR SERVICES WITHIN FUTURE ROAD VARIABLE WIDTH (LIMITED IN STRATUM)

STANDARD WHOLE OF LOT EASEMENTS AFFECTING THE WHOLE OF LOT 203

- (1) - EASEMENT FOR SUPPORT AND SHELTER
- (2) - EASEMENT FOR SERVICES
- (3) - EASEMENT FOR FIRE STAIRS AND PASSAGES
- (4) - EASEMENT TO ACCESS SHARED FACILITIES

STANDARD WATER TREATMENT PLANT AND CENTRAL THERMAL PLANT EASEMENTS THAT MAY AFFECT PART OF LOT 203

- (SUBJECT TO SURVEY OF SERVICE PIPELINES)
- (1) - EASEMENT FOR CENTRAL THERMAL PLANT RETICULATION AND SERVICE INFRASTRUCTURE VARIABLE WIDTH
 - (2) - EASEMENT FOR COLLECTION AND PASSAGE OF STORMWATER VARIABLE WIDTH
 - (3) - EASEMENT FOR RECYCLED WATER PLANT SEWERAGE RETICULATION VARIABLE WIDTH
 - (4) - EASEMENT FOR RECYCLED WATER PLANT RECYCLED WATER RETICULATION INFRASTRUCTURE VARIABLE WIDTH
 - (5) - EASEMENT FOR POTABLE COLD WATER SERVICE VARIABLE WIDTH

WHOLE OF LOT EASEMENTS AFFECTING LOTS 201, 202, 203, 206, 209, 210, 211, 212, 213, 214 & 215

- EASEMENT FOR SUPPORT AND SHELTER
- EASEMENT TO SERVICES
- EASEMENT FOR FIRE STAIRS & PASSAGES
- EASEMENT TO ACCESS FACILITIES

SCHEDULE OF STRATUM LOTS WITHIN STAGES 1 & 2

- STAGE 1 LOTS
- LOT 201 - BLOCK 4S STUDENT ACCOMMODATION STRATUM LOT
 - LOT 202 - CENTRAL THERMAL PLANT (CTP) STAGE 2 STRATUM LOT.
 - LOT 203 - BREWERY YARD STRATUM LOT
 - LOT 204 - PUBLIC ROAD STRATUM LOT
 - LOT 205 - OPEN SPACE STRATUM LOT
 - LOT 206 - BLOCK 4S RETAIL STRATUM LOT
 - LOT 207 - 'PUB' STRATUM LOT
 - LOT 208 - 'TERRACE' STRATUM LOT
 - LOT 209 - BLOCK 1 RESIDENTIAL STRATUM LOT
 - LOT 210 - BLOCK 1 RETAIL STRATUM LOT
 - LOT 211 - BLOCK 4N HOTEL STRATUM LOT
 - LOT 212 - BLOCK 4N COMMERCIAL STRATUM LOT
 - LOT 213 - BLOCK 4N CHILDCARE STRATUM LOT
 - LOT 214 - BREWERY YARD PARKING STRATUM LOT
 - LOT 215 - BLOCK 4N RESIDENTIAL STRATUM LOT

Surveyor: TASY MORAITIS Date of Survey: Surveyor's Ref: 080401 SL2 SUB	PLAN OF SUBDIVISION OF LOT 200 & 201 IN D.P. 1212253 AND LOT 1 IN D.P. 807298 SUBDIVISION OF BLOCK 1, BLOCK 1 NORTH, BLOCK 4 SOUTH AND BREWERY YARD IN 2 STAGES	LGA: SYDNEY Locality: CHIPPENDALE Subdivision No: Lengths are in metres. Reduction Ratio 1:500	REGISTERED CONTRACT PLAN Plan compiled from architectural CAD data. Plan is subject to final survey after completion of construction.	DRAFT PRINTED 18 NOV 2016 ISSUE 14 STAGE 4
--	--	---	---	--

LEVEL 1



STREET

BROADWAY

CHIPPENDALE WAY

ABERCROMBIE

ROAD WIDENING

ROAD

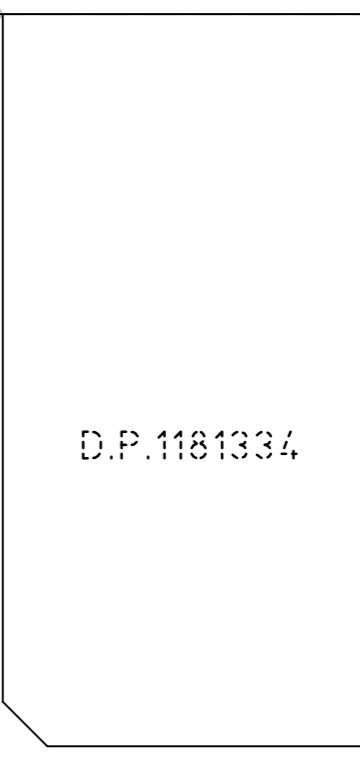
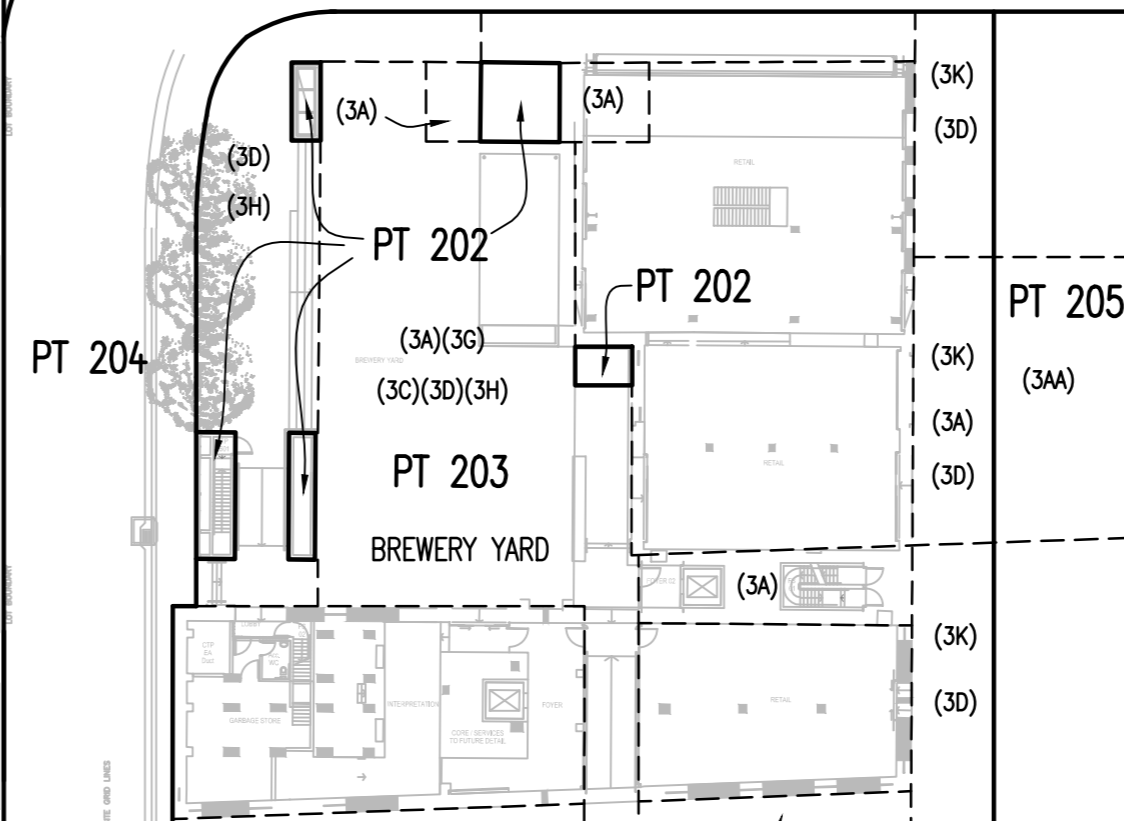
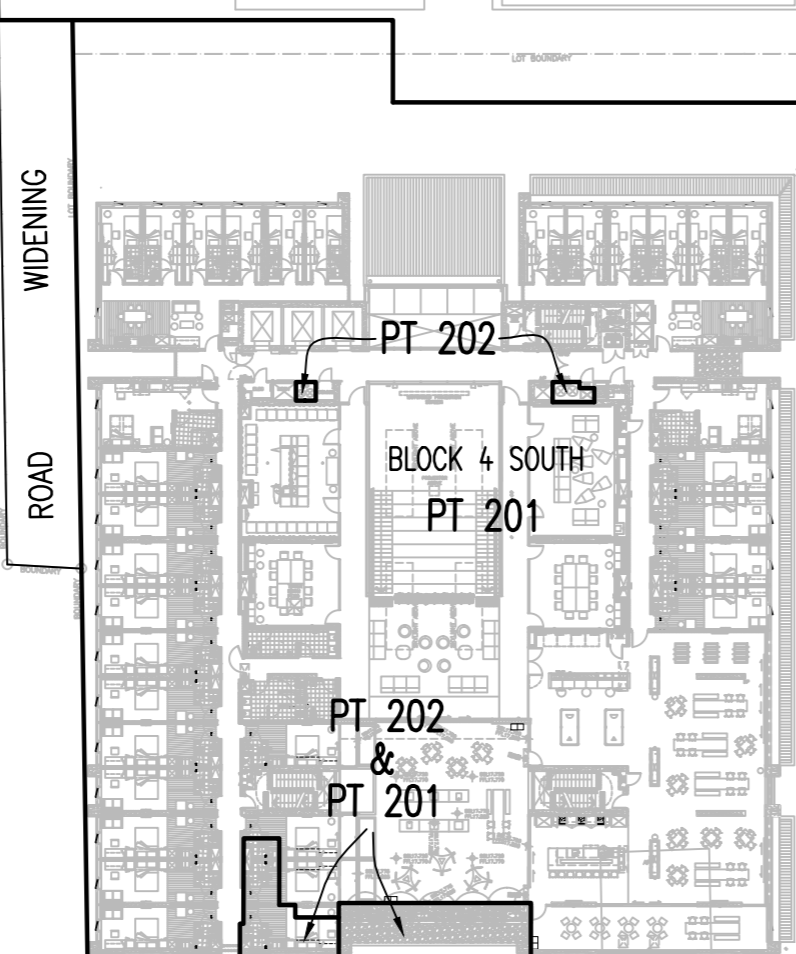
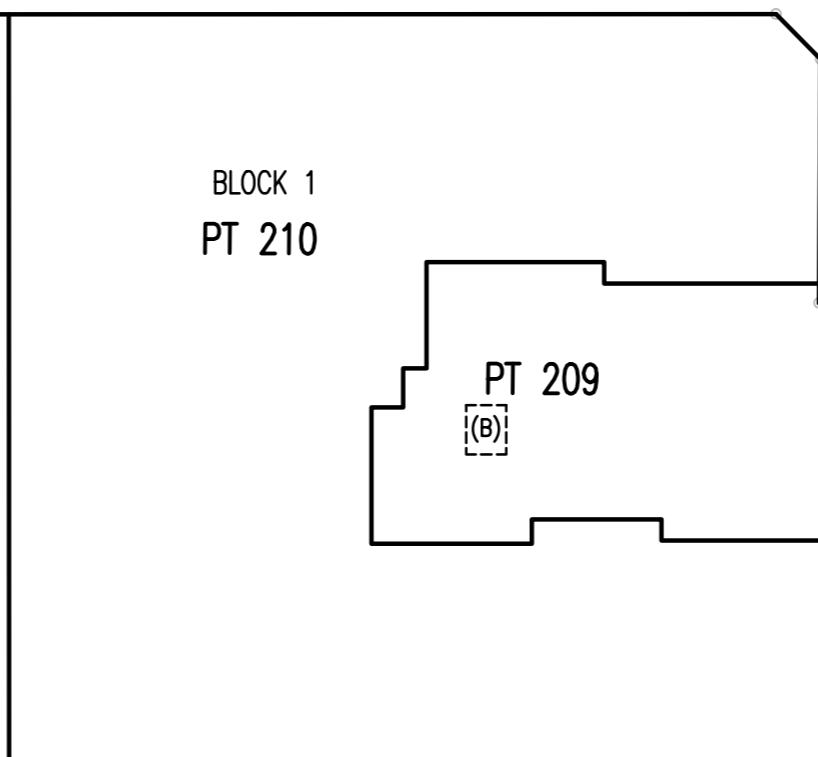
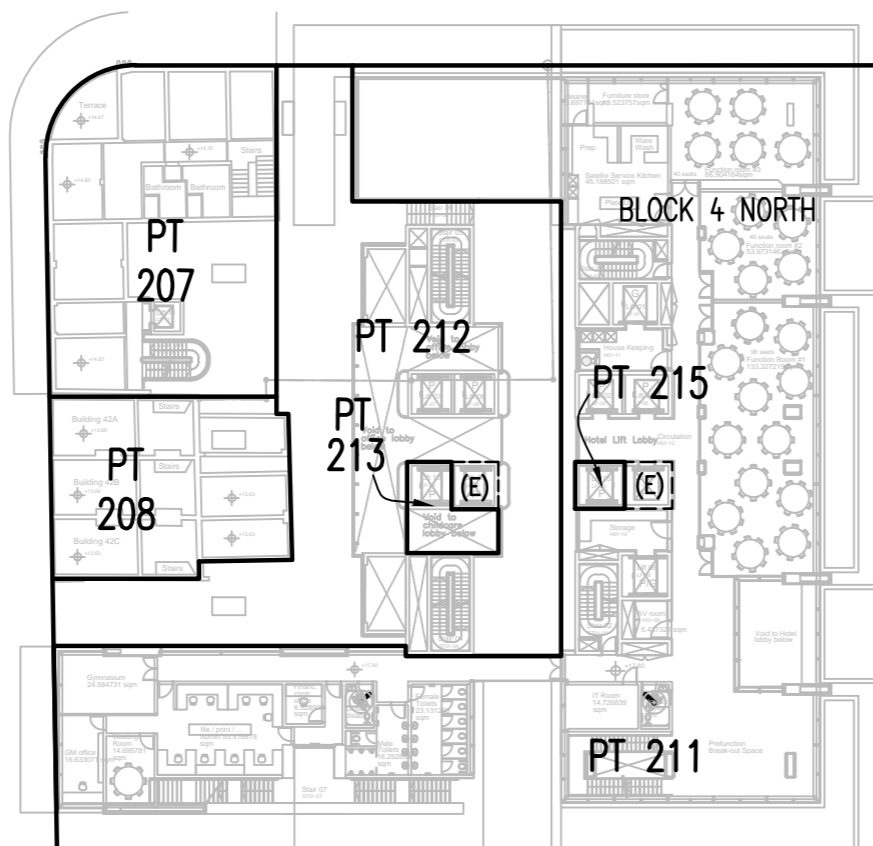

ALL THE EASEMENT NOTES BELOW ARE SUBJECT TO DEVELOPMENTS DESIGN AND FINAL SURVEY

PROPOSED EASEMENTS WITH RESPECT TO LOT 203

- (3A) - EASEMENT TO ACCESS AND MAINTAIN CTP TOWER INFRASTRUCTURE
- (3AA) - EASEMENT FOR MAINTENANCE AND REPAIR OF SEWER MINING PITS
- (3C) - EASEMENT TO ACCESS BREWERY YARD FOR MAINTENANCE AND REPAIR VARIABLE WIDTH
- (3D) - EASEMENT FOR CTP ACCESS VARIABLE WIDTH
- (3F) - EASEMENT TO ACCESS AND SERVICE FIRE SERVICES (SITE TO BE DETERMINED)
- (3G) - EASEMENT FOR TEMPORARY ART INSTALLATION VARIABLE WIDTH
- (3H) - EASEMENT FOR PUBLIC PEDESTRIAN ACCESS VARIABLE WIDTH
- (3K) - EASEMENT FOR AUSGRID ACCESS VARIABLE WIDTH
- (B) - EASEMENT TO ACCESS AND USE LIFTS VARIABLE WIDTH (LIMITED IN STRATUM)
- (E) - EASEMENT TO ACCESS AND USE LIFTS VARIABLE WIDTH (LIMITED IN STRATUM)

STANDARD WHOLE OF LOT EASEMENTS AFFECTING THE WHOLE OF LOT 203

- (1) - EASEMENT FOR SUPPORT AND SHELTER
- (2) - EASEMENT FOR SERVICES
- (3) - EASEMENT FOR FIRE STAIRS AND PASSAGES
- (4) - EASEMENT TO ACCESS SHARED FACILITIES

STANDARD WATER TREATMENT PLANT AND CENTRAL THERMAL PLANT EASEMENTS THAT MAY AFFECT PART OF LOT 203

(SUBJECT TO SURVEY OF SERVICE PIPELINES)

- (1) - EASEMENT FOR CENTRAL THERMAL PLANT RETICULATION AND SERVICE INFRASTRUCTURE VARIABLE WIDTH
- (2) - EASEMENT FOR COLLECTION AND PASSAGE OF STORMWATER VARIABLE WIDTH
- (3) - EASEMENT FOR RECYCLED WATER PLANT SEWERAGE RETICULATION VARIABLE WIDTH
- (4) - EASEMENT FOR RECYCLED WATER PLANT RECYCLED WATER RETICULATION INFRASTRUCTURE VARIABLE WIDTH
- (5) - EASEMENT FOR POTABLE COLD WATER SERVICE VARIABLE WIDTH

WHOLE OF LOT EASEMENTS AFFECTING LOTS 201, 202, 203, 206, 209, 210, 211, 212, 213, 214 & 215

- EASEMENT FOR SUPPORT AND SHELTER
- EASEMENT TO SERVICES
- EASEMENT FOR FIRE STAIRS & PASSAGES
- EASEMENT TO ACCESS FACILITIES

ROAD WIDENING ONLY EXISTS UPTO LEVEL 1 LAND FORMS PART OF LOT 401 ABOVE LEVEL 1

SCHEDULE OF STRATUM LOTS WITHIN STAGES 1 & 2

STAGE 1 LOTS

- LOT 201 - BLOCK 4S STUDENT ACCOMMODATION STRATUM LOT
- LOT 202 - CENTRAL THERMAL PLANT (CTP) STAGE 2 STRATUM LOT.
- LOT 203 - BREWERY YARD STRATUM LOT
- LOT 204 - PUBLIC ROAD STRATUM LOT
- LOT 205 - OPEN SPACE STRATUM LOT
- LOT 206 - BLOCK 4S RETAIL STRATUM LOT
- LOT 207 - 'PUB' STRATUM LOT
- LOT 208 - 'TERRACE' STRATUM LOT
- LOT 209 - BLOCK 1 RESIDENTIAL STRATUM LOT
- LOT 210 - BLOCK 1 RETAIL STRATUM LOT
- LOT 211 - BLOCK 4N HOTEL STRATUM LOT
- LOT 212 - BLOCK 4N COMMERCIAL STRATUM LOT
- LOT 213 - BLOCK 4N CHILDCARE STRATUM LOT
- LOT 214 - BREWERY YARD PARKING STRATUM LOT
- LOT 215 - BLOCK 4N RESIDENTIAL STRATUM LOT

1
D.P. 1194122

Surveyor: TASY MORAITIS
Date of Survey:
Surveyor's Ref: 080401 SL2 SUB

PLAN OF SUBDIVISION OF LOT 200 & 201 IN D.P. 1212253 AND LOT 1 IN D.P. 807298

SUBDIVISION OF BLOCK 1, BLOCK 1 NORTH, BLOCK 4 SOUTH AND BREWERY YARD IN 2 STAGES

LGA: SYDNEY
Locality: CHIPPENDALE
Subdivision No:
Lengths are in metres. Reduction Ratio 1:500

REGISTERED
CONTRACT PLAN
Plan compiled from
architectural CAD data.
Plan is subject to final
survey after completion
of construction.

DRAFT
PRINTED 18 NOV 2016
ISSUE 14
STAGE 4

LEVEL 2

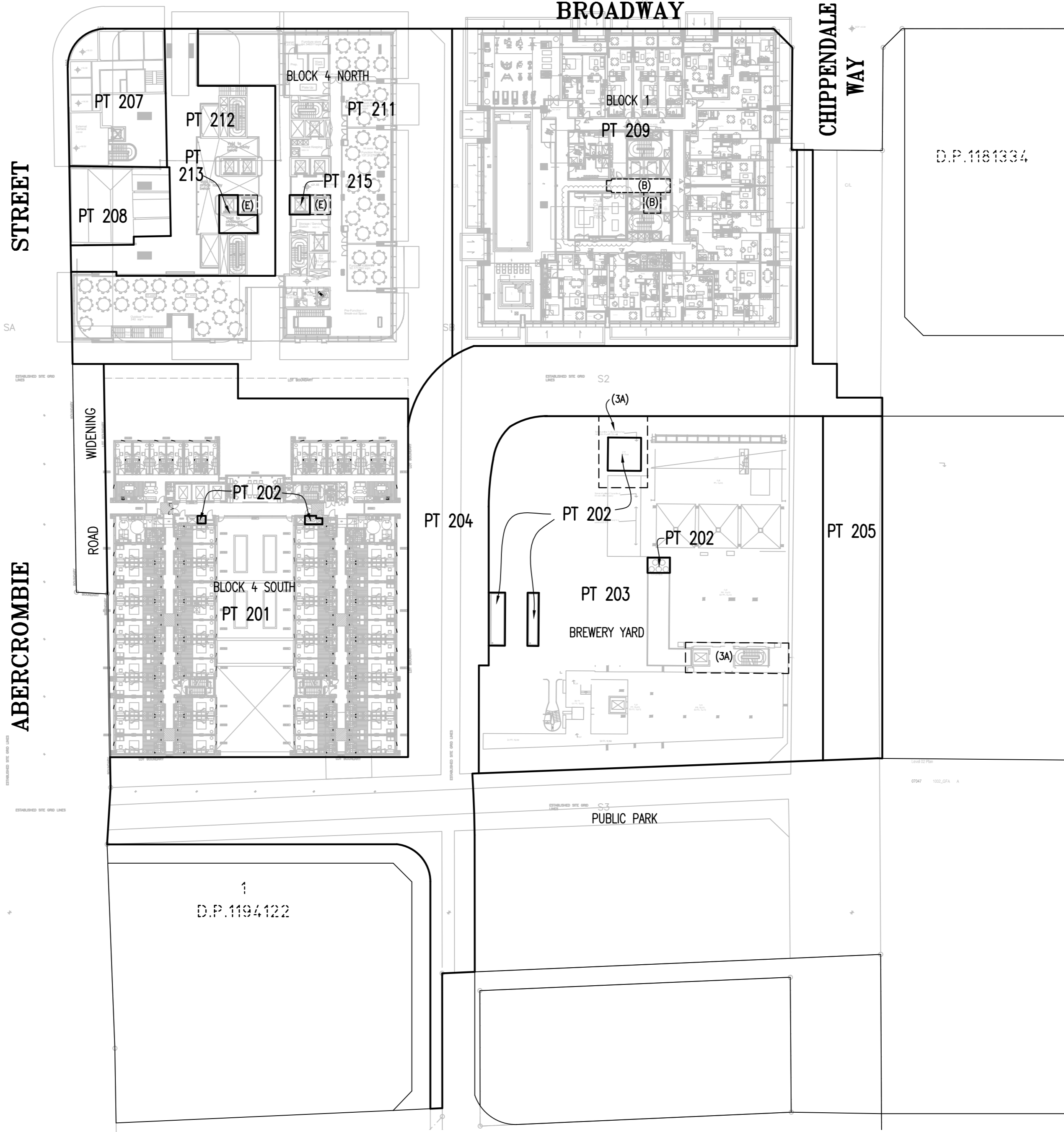

D.P. 1181334

PROPOSED EASEMENTS WITH RESPECT TO LOT 203

- (3A) - EASEMENT TO ACCESS AND MAINTAIN CTP TOWER INFRASTRUCTURE
- (B) - EASEMENT TO ACCESS AND USE LIFTS VARIABLE WIDTH (LIMITED IN STRATUM)
- (E) - EASEMENT TO ACCESS AND USE LIFTS VARIABLE WIDTH (LIMITED IN STRATUM)

- WHOLE OF LOT EASEMENTS AFFECTING LOTS 201, 202, 203, 206, 209, 210, 211, 212, 213, 214 & 215
- EASEMENT FOR SUPPORT AND SHELTER
 - EASEMENT TO SERVICES
 - EASEMENT FOR FIRE STAIRS & PASSAGES
 - EASEMENT TO ACCESS FACILITIES

SCHEDULE OF STRATUM LOTS WITHIN STAGES 1 & 2

STAGE 1 LOTS

- LOT 201 - BLOCK 4S STUDENT ACCOMMODATION STRATUM LOT
- LOT 202 - CENTRAL THERMAL PLANT (CTP) STAGE 2 STRATUM LOT.
- LOT 203 - BREWERY YARD STRATUM LOT
- LOT 204 - PUBLIC ROAD STRATUM LOT
- LOT 205 - OPEN SPACE STRATUM LOT
- LOT 206 - BLOCK 4S RETAIL STRATUM LOT
- LOT 207 - 'PUB' STRATUM LOT
- LOT 208 - 'TERRACE' STRATUM LOT
- LOT 209 - BLOCK 1 RESIDENTIAL STRATUM LOT
- LOT 210 - BLOCK 1 RETAIL STRATUM LOT
- LOT 211 - BLOCK 4N HOTEL STRATUM LOT
- LOT 212 - BLOCK 4N COMMERCIAL STRATUM LOT
- LOT 213 - BLOCK 4N CHILDCARE STRATUM LOT
- LOT 214 - BREWERY YARD PARKING STRATUM LOT
- LOT 215 - BLOCK 4N RESIDENTIAL STRATUM LOT

Surveyor: TASY MORAITIS
 Date of Survey:
 Surveyor's Ref: 080401 SL2 SUB

PLAN OF SUBDIVISION OF LOT 200 & 201 IN D.P. 1212253 AND LOT 1 IN D.P. 807298
 SUBDIVISION OF BLOCK 1, BLOCK 1 NORTH, BLOCK 4 SOUTH AND BREWERY YARD IN 2 STAGES

LGA: SYDNEY
 Locality: CHIPPENDALE
 Subdivision No:
 Lengths are in metres. Reduction Ratio 1:500

REGISTERED CONTRACT PLAN
 Plan compiled from architectural CAD data.
 Plan is subject to final survey after completion of construction.

DRAFT
 PRINTED 18 NOV 2016
 ISSUE 14
 STAGE 4

LEVEL 3



STREET

BROADWAY

CHIPPENDALE WAY

ABERCROMBIE

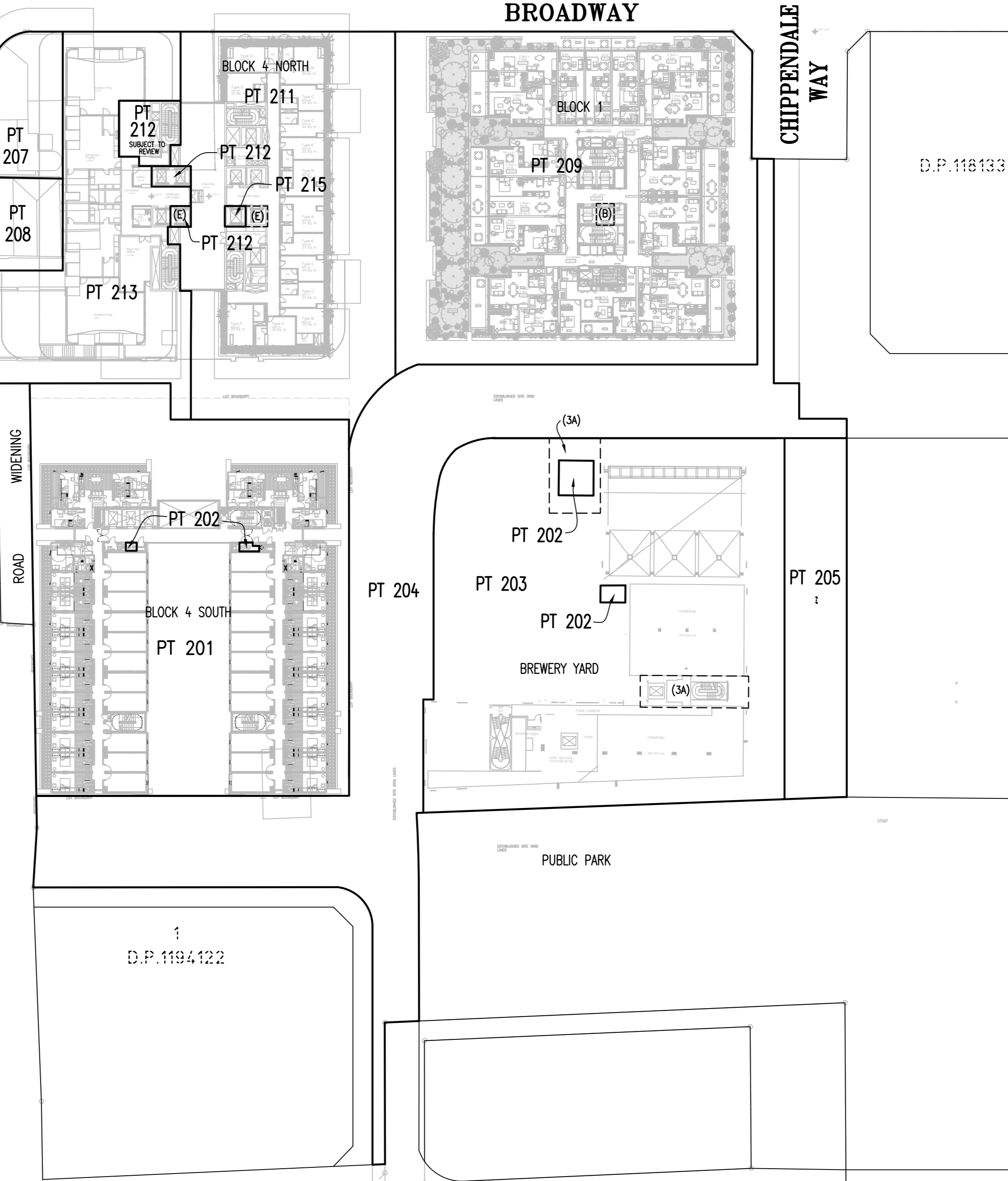

D.P.1181334

PROPOSED EASEMENTS WITH RESPECT TO LOT 203

- (3A) - EASEMENT TO ACCESS AND MAINTAIN CTP TOWER INFRASTRUCTURE
- (B) - EASEMENT TO ACCESS AND USE LIFTS VARIABLE WIDTH (LIMITED IN STRATUM)
- (E) - EASEMENT TO ACCESS AND USE LIFTS VARIABLE WIDTH (LIMITED IN STRATUM)

WHOLE OF LOT EASEMENTS AFFECTING LOTS 201, 202, 203, 206, 209, 210, 211, 212, 213, 214 & 215

- EASEMENT FOR SUPPORT AND SHELTER
- EASEMENT TO SERVICES
- EASEMENT FOR FIRE STAIRS & PASSAGES
- EASEMENT TO ACCESS FACILITIES

SCHEDULE OF STRATUM LOTS WITHIN STAGES 1 & 2

STAGE 1 LOTS

- LOT 201 - BLOCK 4S STUDENT ACCOMMODATION STRATUM LOT
- LOT 202 - CENTRAL THERMAL PLANT (CTP) STAGE 2 STRATUM LOT.
- LOT 203 - BREWERY YARD STRATUM LOT
- LOT 204 - PUBLIC ROAD STRATUM LOT
- LOT 205 - OPEN SPACE STRATUM LOT
- LOT 206 - BLOCK 4S RETAIL STRATUM LOT
- LOT 207 - 'PUB' STRATUM LOT
- LOT 208 - 'TERRACE' STRATUM LOT
- LOT 209 - BLOCK 1 RESIDENTIAL STRATUM LOT
- LOT 210 - BLOCK 1 RETAIL STRATUM LOT
- LOT 211 - BLOCK 4N HOTEL STRATUM LOT
- LOT 212 - BLOCK 4N COMMERCIAL STRATUM LOT
- LOT 213 - BLOCK 4N CHILDCARE STRATUM LOT
- LOT 214 - BREWERY YARD PARKING STRATUM LOT
- LOT 215 - BLOCK 4N RESIDENTIAL STRATUM LOT

D.P.1194122

Surveyor: TASY MORAITIS
 Date of Survey:
 Surveyor's Ref: 080401 SL2 SUB

PLAN OF SUBDIVISION OF LOT 200 & 201 IN
 D.P. 1212253 AND LOT 1 IN D.P. 807298

SUBDIVISION OF BLOCK 1, BLOCK 1 NORTH,
 BLOCK 4 SOUTH AND
 BREWERY YARD IN 2 STAGES

LGA: SYDNEY
 Locality: CHIPPENDALE
 Subdivision No:
 Lengths are in metres. Reduction Ratio 1:500

REGISTERED
 CONTRACT PLAN
 Plan compiled from
 architectural CAD data.
 Plan is subject to final
 survey after completion
 of construction.

DRAFT
 PRINTED 18 NOV 2016
 ISSUE 14
 STAGE 4

LEVEL 4



STREET

ABERCROMBIE

BROADWAY

CHIPPENDALE WAY

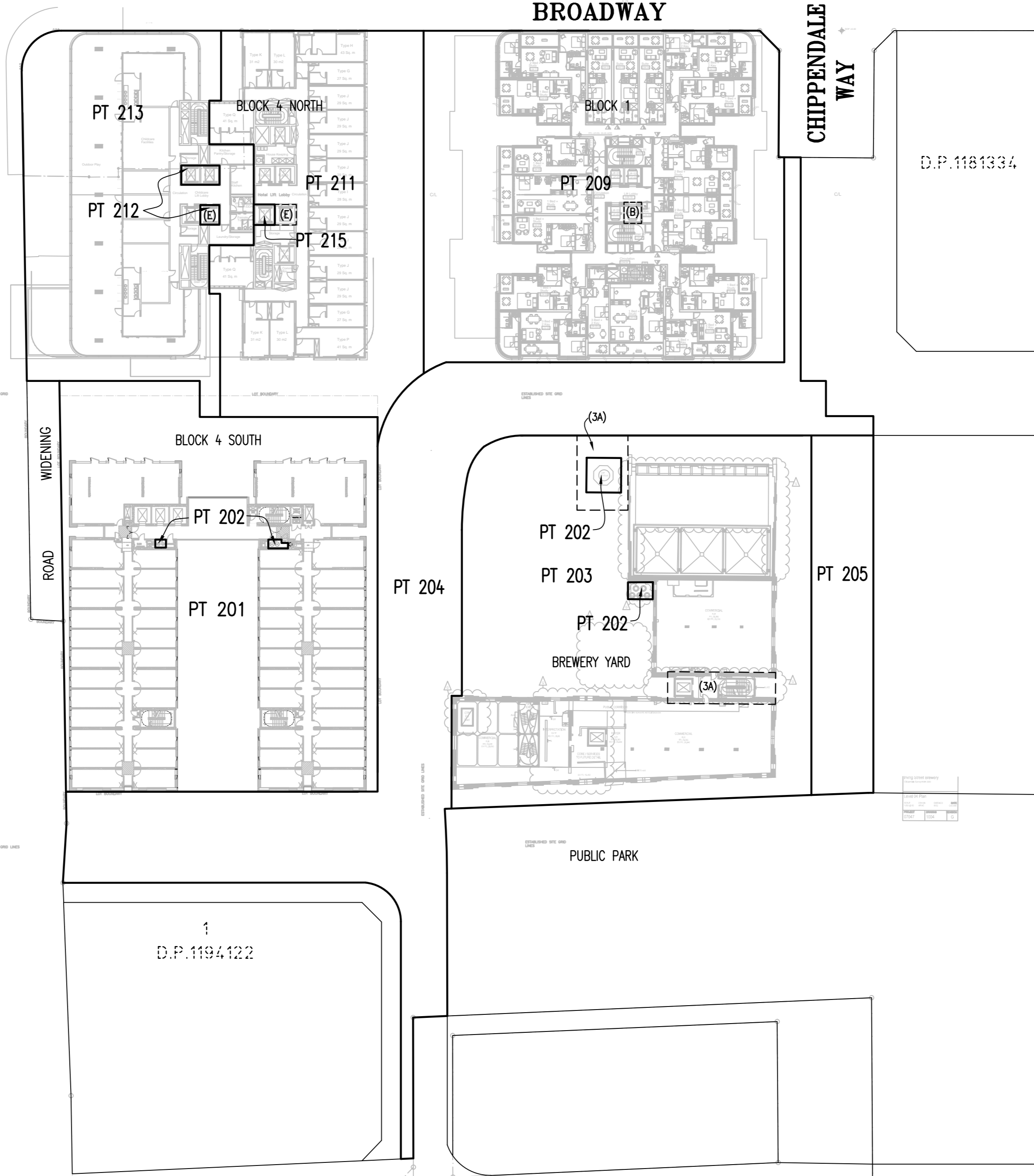

D.P. 1181334

PROPOSED EASEMENTS WITH RESPECT TO LOT 203

- (3A) - EASEMENT TO ACCESS AND MAINTAIN CTP TOWER INFRASTRUCTURE
- (B) - EASEMENT TO ACCESS AND USE LIFTS VARIABLE WIDTH (LIMITED IN STRATUM)
- (E) - EASEMENT TO ACCESS AND USE LIFTS VARIABLE WIDTH (LIMITED IN STRATUM)

- WHOLE OF LOT EASEMENTS AFFECTING LOTS 201, 202, 203, 206, 209, 210, 211, 212, 213, 214 & 215
- EASEMENT FOR SUPPORT AND SHELTER
 - EASEMENT TO SERVICES
 - EASEMENT FOR FIRE STAIRS & PASSAGES
 - EASEMENT TO ACCESS FACILITIES

SCHEDULE OF STRATUM LOTS WITHIN STAGES 1 & 2

STAGE 1 LOTS

- LOT 201 - BLOCK 4S STUDENT ACCOMMODATION STRATUM LOT
- LOT 202 - CENTRAL THERMAL PLANT (CTP) STAGE 2 STRATUM LOT.
- LOT 203 - BREWERY YARD STRATUM LOT
- LOT 204 - PUBLIC ROAD STRATUM LOT
- LOT 205 - OPEN SPACE STRATUM LOT
- LOT 206 - BLOCK 4S RETAIL STRATUM LOT
- LOT 207 - 'PUB' STRATUM LOT
- LOT 208 - 'TERRACE' STRATUM LOT
- LOT 209 - BLOCK 1 RESIDENTIAL STRATUM LOT
- LOT 210 - BLOCK 1 RETAIL STRATUM LOT
- LOT 211 - BLOCK 4N HOTEL STRATUM LOT
- LOT 212 - BLOCK 4N COMMERCIAL STRATUM LOT
- LOT 213 - BLOCK 4N CHILDCARE STRATUM LOT
- LOT 214 - BREWERY YARD PARKING STRATUM LOT
- LOT 215 - BLOCK 4N RESIDENTIAL STRATUM LOT

1
D.P. 1194122

Surveyor: TASY MORAITIS
 Date of Survey:
 Surveyor's Ref: 080401 SL2 SUB

PLAN OF SUBDIVISION OF LOT 200 & 201 IN
 D.P. 1212253 AND LOT 1 IN D.P. 807298

SUBDIVISION OF BLOCK 1, BLOCK 1 NORTH,
 BLOCK 4 SOUTH AND
 BREWERY YARD IN 2 STAGES

LGA: SYDNEY
 Locality: CHIPPENDALE
 Subdivision No:
 Lengths are in metres. Reduction Ratio 1: 500

REGISTERED
 CONTRACT PLAN
 Plan compiled from
 architectural CAD data.
 Plan is subject to final
 survey after completion
 of construction.

DRAFT
 PRINTED 18 NOV 2016
 ISSUE 14
 STAGE 4

LEVEL 5



STREET

BROADWAY

CHIPPENDALE WAY

ABERCROMBIE

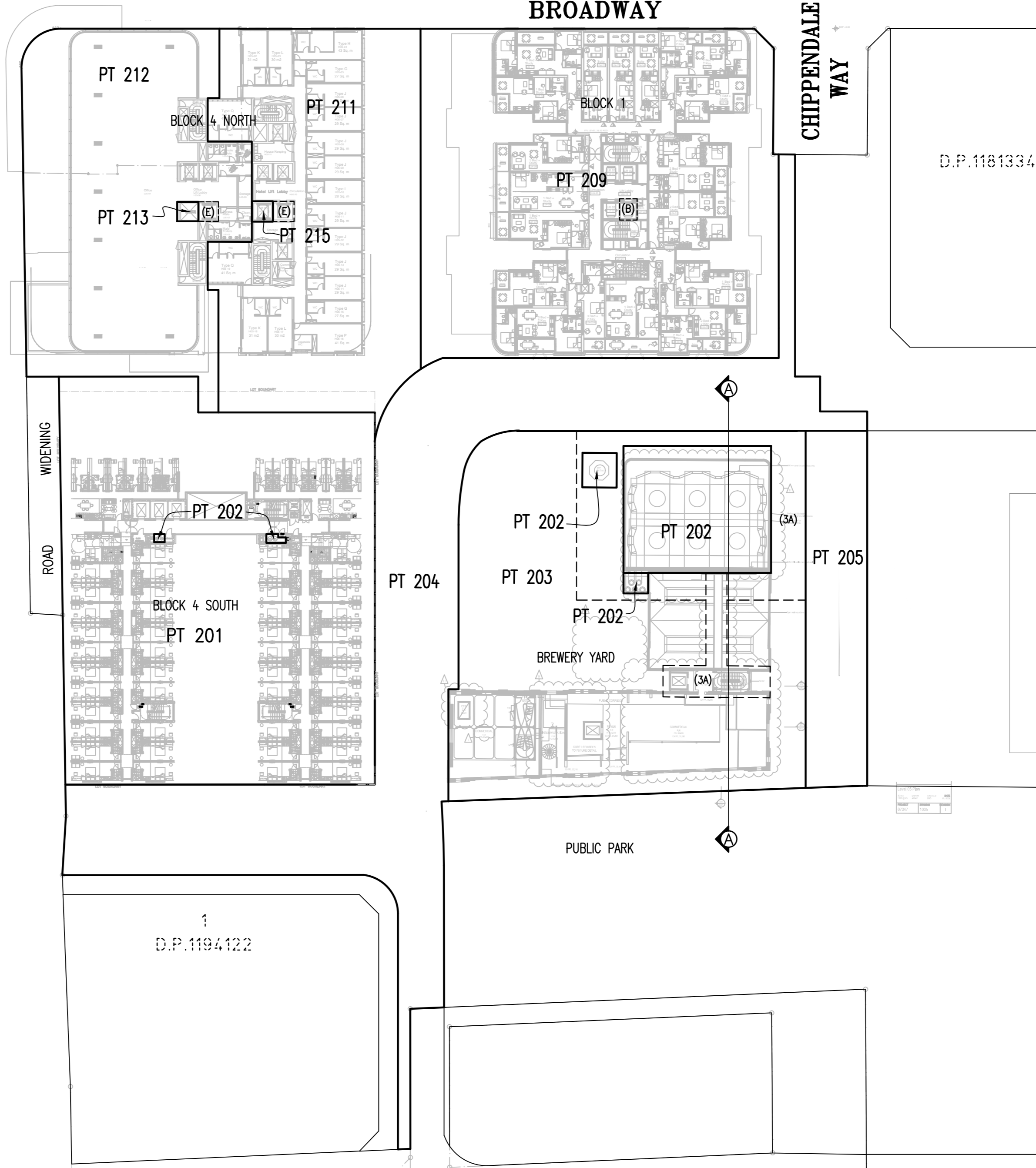

D.P.1181334

PROPOSED EASEMENTS WITH RESPECT TO LOT 203

- (3A) - EASEMENT TO ACCESS AND MAINTAIN CTP TOWER INFRASTRUCTURE
- (B) - EASEMENT TO ACCESS AND USE LIFTS VARIABLE WIDTH (LIMITED IN STRATUM)
- (E) - EASEMENT TO ACCESS AND USE LIFTS VARIABLE WIDTH (LIMITED IN STRATUM)

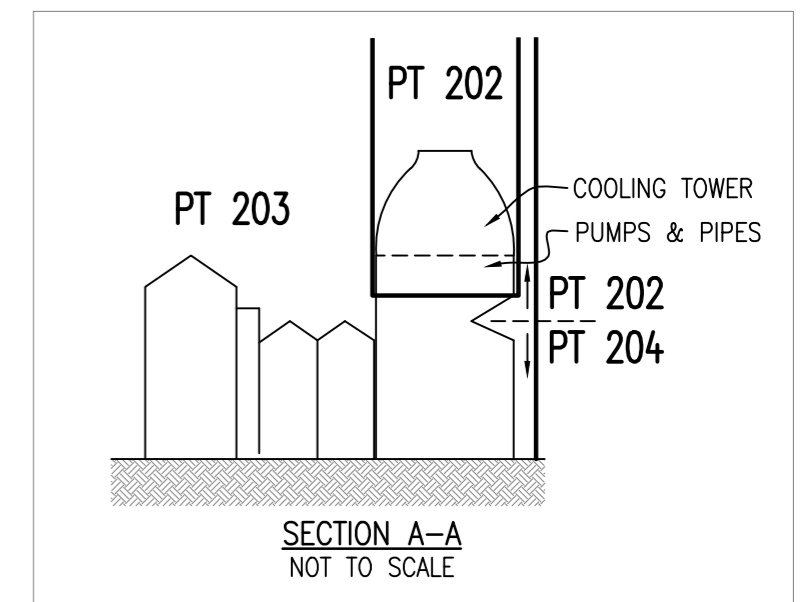

WHOLE OF LOT EASEMENTS AFFECTING LOTS 201, 202, 203, 206, 209, 210, 211, 212, 213, 214 & 215

- EASEMENT FOR SUPPORT AND SHELTER
- EASEMENT TO SERVICES
- EASEMENT FOR FIRE STAIRS & PASSAGES
- EASEMENT TO ACCESS FACILITIES

SCHEDULE OF STRATUM LOTS WITHIN STAGES 1 & 2

STAGE 1 LOTS

- LOT 201 - BLOCK 4S STUDENT ACCOMMODATION STRATUM LOT
- LOT 202 - CENTRAL THERMAL PLANT (CTP) STAGE 2 STRATUM LOT.
- LOT 203 - BREWERY YARD STRATUM LOT
- LOT 204 - PUBLIC ROAD STRATUM LOT
- LOT 205 - OPEN SPACE STRATUM LOT
- LOT 206 - BLOCK 4S RETAIL STRATUM LOT
- LOT 207 - 'PUB' STRATUM LOT
- LOT 208 - 'TERRACE' STRATUM LOT
- LOT 209 - BLOCK 1 RESIDENTIAL STRATUM LOT
- LOT 210 - BLOCK 1 RETAIL STRATUM LOT
- LOT 211 - BLOCK 4N HOTEL STRATUM LOT
- LOT 212 - BLOCK 4N COMMERCIAL STRATUM LOT
- LOT 213 - BLOCK 4N CHILDCARE STRATUM LOT
- LOT 214 - BREWERY YARD PARKING STRATUM LOT
- LOT 215 - BLOCK 4N RESIDENTIAL STRATUM LOT

D.P.1194122

Surveyor: TASY MORAITIS
 Date of Survey:
 Surveyor's Ref: 080401 SL2 SUB

PLAN OF SUBDIVISION OF LOT 200 & 201 IN
 D.P. 1212253 AND LOT 1 IN D.P. 807298

SUBDIVISION OF BLOCK 1, BLOCK 1 NORTH,
 BLOCK 4 SOUTH AND
 BREWERY YARD IN 2 STAGES

LGA: SYDNEY
 Locality: CHIPPENDALE
 Subdivision No:
 Lengths are in metres. Reduction Ratio 1:500

REGISTERED
 CONTRACT PLAN
 Plan compiled from
 architectural CAD data.
 Plan is subject to final
 survey after completion
 of construction.

DRAFT
 PRINTED 18 NOV 2016
 ISSUE 14
 STAGE 4

LEVEL 6



STREET

BROADWAY

CHIPPENDALE WAY

ABERCROMBIE

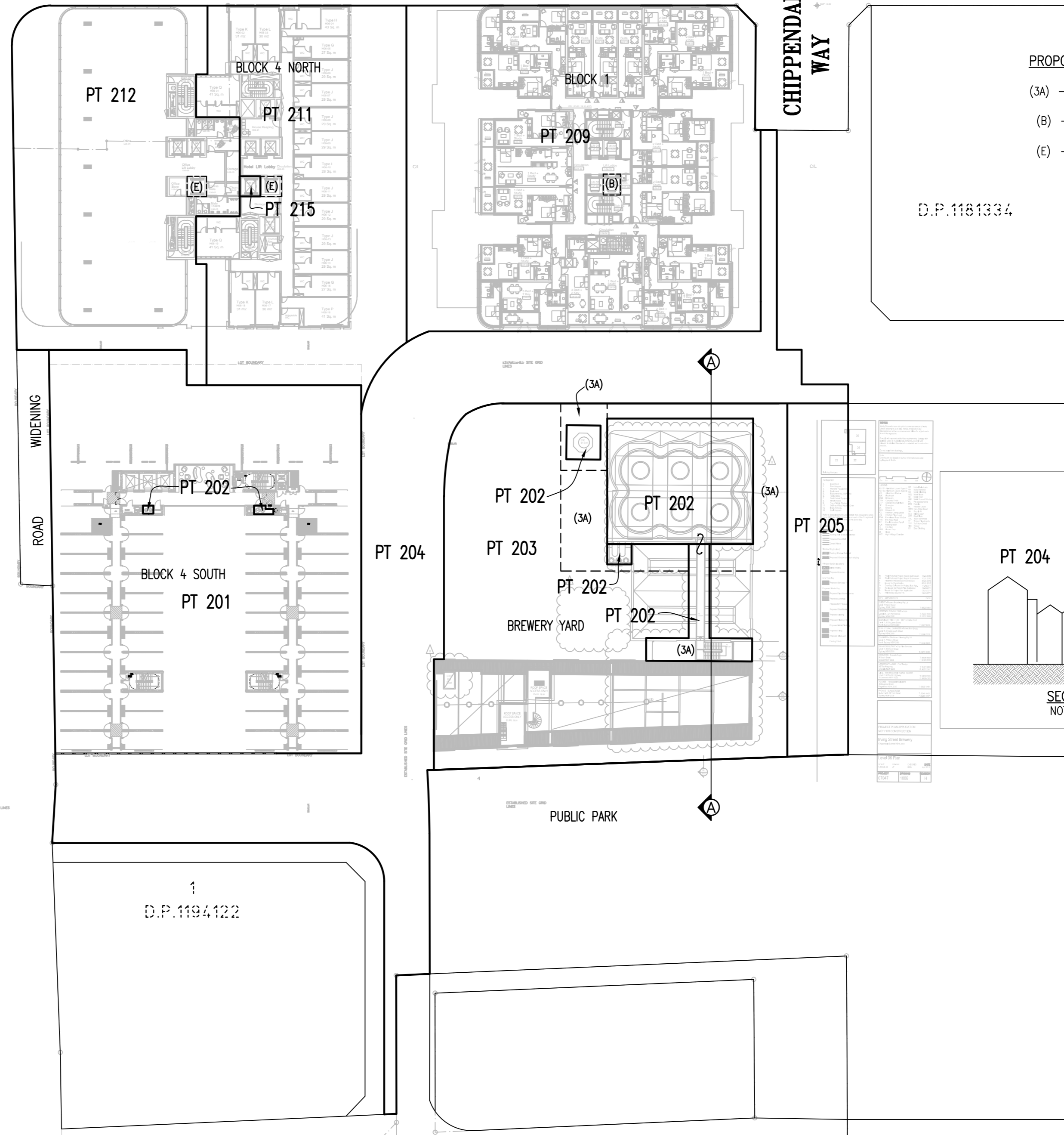

PROPOSED EASEMENTS WITH RESPECT TO LOT 203

- (3A) - EASEMENT TO ACCESS AND MAINTAIN CTP TOWER INFRASTRUCTURE
- (B) - EASEMENT TO ACCESS AND USE LIFTS VARIABLE WIDTH (LIMITED IN STRATUM)
- (E) - EASEMENT TO ACCESS AND USE LIFTS VARIABLE WIDTH (LIMITED IN STRATUM)

D.P.1181334

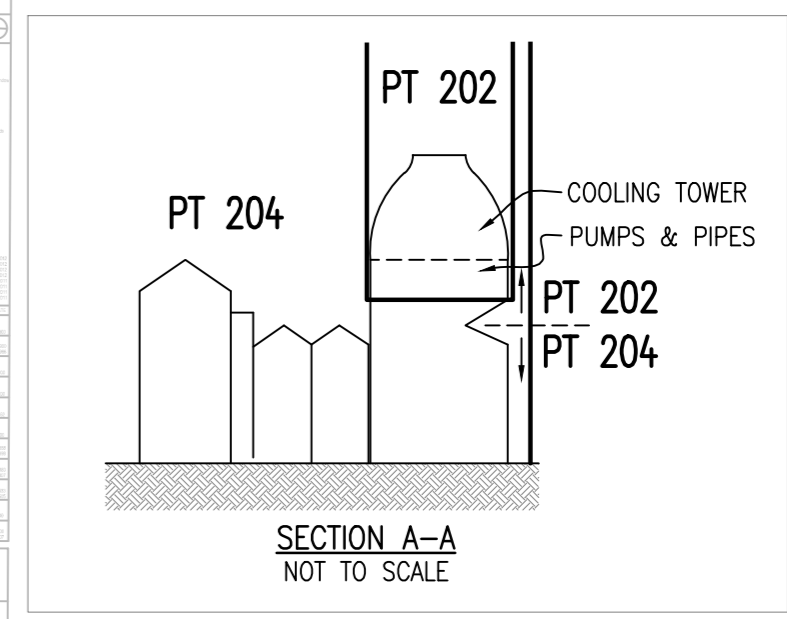

- WHOLE OF LOT EASEMENTS AFFECTING LOTS 201, 202, 203, 206, 209, 210, 211, 212, 213, 214 & 215
- EASEMENT FOR SUPPORT AND SHELTER
 - EASEMENT TO SERVICES
 - EASEMENT FOR FIRE STAIRS & PASSAGES
 - EASEMENT TO ACCESS FACILITIES

SCHEDULE OF STRATUM LOTS WITHIN STAGES 1 & 2

- STAGE 1 LOTS
- LOT 201 - BLOCK 4S STUDENT ACCOMMODATION STRATUM LOT
 - LOT 202 - CENTRAL THERMAL PLANT (CTP) STAGE 2 STRATUM LOT.
 - LOT 203 - BREWERY YARD STRATUM LOT
 - LOT 204 - PUBLIC ROAD STRATUM LOT
 - LOT 205 - OPEN SPACE STRATUM LOT
 - LOT 206 - BLOCK 4S RETAIL STRATUM LOT
 - LOT 207 - 'PUB' STRATUM LOT
 - LOT 208 - 'TERRACE' STRATUM LOT
 - LOT 209 - BLOCK 1 RESIDENTIAL STRATUM LOT
 - LOT 210 - BLOCK 1 RETAIL STRATUM LOT
 - LOT 211 - BLOCK 4N HOTEL STRATUM LOT
 - LOT 212 - BLOCK 4N COMMERCIAL STRATUM LOT
 - LOT 213 - BLOCK 4N CHILDCARE STRATUM LOT
 - LOT 214 - BREWERY YARD PARKING STRATUM LOT
 - LOT 215 - BLOCK 4N RESIDENTIAL STRATUM LOT

Surveyor: TASY MORAITIS
 Date of Survey:
 Surveyor's Ref: 080401 SL2 SUB

PLAN OF SUBDIVISION OF LOT 200 & 201 IN D.P. 1212253 AND LOT 1 IN D.P. 807298

SUBDIVISION OF BLOCK 1, BLOCK 1 NORTH, BLOCK 4 SOUTH AND BREWERY YARD IN 2 STAGES

LGA: SYDNEY
 Locality: CHIPPENDALE
 Subdivision No:
 Lengths are in metres. Reduction Ratio 1:500

REGISTERED CONTRACT PLAN
 Plan compiled from architectural CAD data.
 Plan is subject to final survey after completion of construction.

DRAFT
 PRINTED 18 NOV 2016
 ISSUE 14
 STAGE 4



STREET

ABERCROMBIE

BROADWAY

CHIPPENDALE WAY

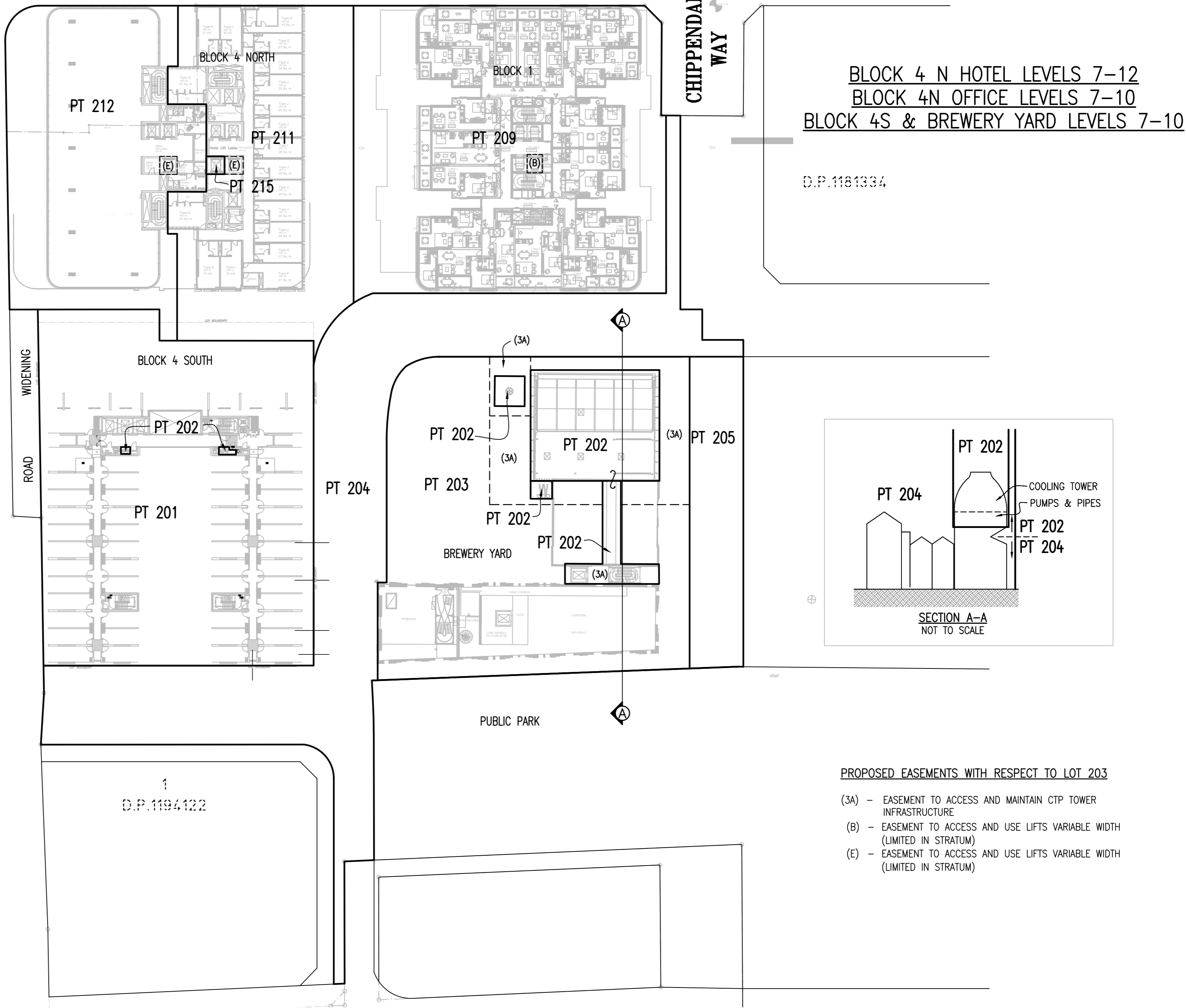

BLOCK 4 N HOTEL LEVELS 7-12
 BLOCK 4N OFFICE LEVELS 7-10
 BLOCK 4S & BREWERY YARD LEVELS 7-10

D.P.1181334

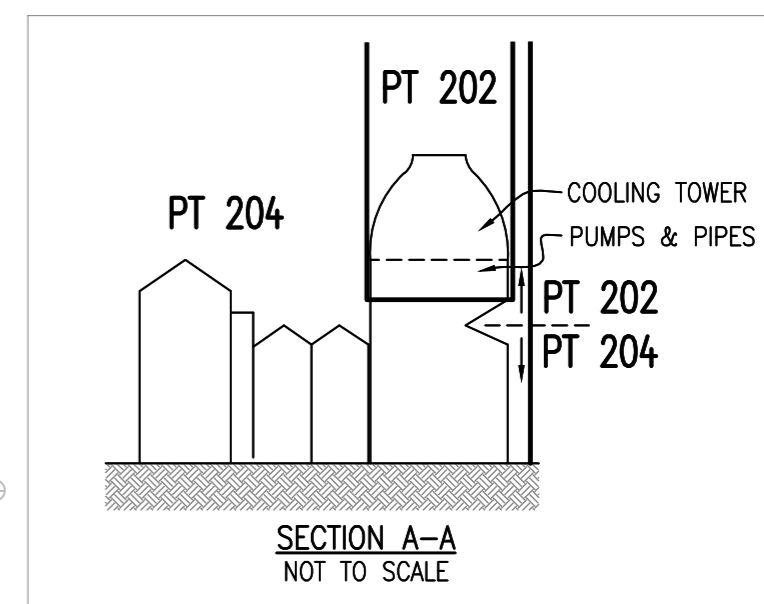

- WHOLE OF LOT EASEMENTS AFFECTING LOTS 201, 202, 203, 206, 209, 210, 211, 212, 213, 214 & 215
- EASEMENT FOR SUPPORT AND SHELTER
 - EASEMENT TO SERVICES
 - EASEMENT FOR FIRE STAIRS & PASSAGES
 - EASEMENT TO ACCESS FACILITIES

SCHEDULE OF STRATUM LOTS WITHIN STAGES 1 & 2

STAGE 1 LOTS

- LOT 201 - BLOCK 4S STUDENT ACCOMMODATION STRATUM LOT
- LOT 202 - CENTRAL THERMAL PLANT (CTP) STAGE 2 STRATUM LOT.
- LOT 203 - BREWERY YARD STRATUM LOT
- LOT 204 - PUBLIC ROAD STRATUM LOT
- LOT 205 - OPEN SPACE STRATUM LOT
- LOT 206 - BLOCK 4S RETAIL STRATUM LOT
- LOT 207 - 'PUB' STRATUM LOT
- LOT 208 - 'TERRACE' STRATUM LOT
- LOT 209 - BLOCK 1 RESIDENTIAL STRATUM LOT
- LOT 210 - BLOCK 1 RETAIL STRATUM LOT
- LOT 211 - BLOCK 4N HOTEL STRATUM LOT
- LOT 212 - BLOCK 4N COMMERCIAL STRATUM LOT
- LOT 213 - BLOCK 4N CHILDCARE STRATUM LOT
- LOT 214 - BREWERY YARD PARKING STRATUM LOT
- LOT 215 - BLOCK 4N RESIDENTIAL STRATUM LOT

PROPOSED EASEMENTS WITH RESPECT TO LOT 203

- (3A) - EASEMENT TO ACCESS AND MAINTAIN CTP TOWER INFRASTRUCTURE
- (B) - EASEMENT TO ACCESS AND USE LIFTS VARIABLE WIDTH (LIMITED IN STRATUM)
- (E) - EASEMENT TO ACCESS AND USE LIFTS VARIABLE WIDTH (LIMITED IN STRATUM)

Surveyor: TASY MORAITIS Date of Survey: Surveyor's Ref: 080401 SL2 SUB	PLAN OF SUBDIVISION OF LOT 200 & 201 IN D.P. 1212253 AND LOT 1 IN D.P. 807298 SUBDIVISION OF BLOCK 1, BLOCK 1 NORTH, BLOCK 4 SOUTH AND BREWERY YARD IN 2 STAGES	LGA: SYDNEY Locality: CHIPPENDALE Subdivision No: Lengths are in metres. Reduction Ratio 1:500	REGISTERED CONTRACT PLAN Plan compiled from architectural CAD data. Plan is subject to final survey after completion of construction.	DRAFT PRINTED 18 NOV 2016 ISSUE 14 STAGE 4
--	--	---	---	--

BLOCK 4N HOTEL LEVEL 13
BLOCK 4N RESIDENTIAL LEVEL 11
BLOCK 4S LEVELS 11 - 14



STREET

ABERCROMBIE

BROADWAY

CHIPPENDALE WAY



- (B) - EASEMENT TO ACCESS AND USE LIFTS VARIABLE WIDTH (LIMITED IN STRATUM)
- (E) - EASEMENT TO ACCESS AND USE LIFTS VARIABLE WIDTH (LIMITED IN STRATUM)

D.P. 1181334

WHOLE OF LOT EASEMENTS AFFECTING LOTS 201, 202, 203, 206, 209, 210, 211, 212, 213, 214 & 215

- EASEMENT FOR SUPPORT AND SHELTER
- EASEMENT TO SERVICES
- EASEMENT FOR FIRE STAIRS & PASSAGES
- EASEMENT TO ACCESS FACILITIES

SCHEDULE OF STRATUM LOTS WITHIN STAGES 1 & 2

STAGE 1 LOTS

- LOT 201 - BLOCK 4S STUDENT ACCOMMODATION STRATUM LOT
- LOT 202 - CENTRAL THERMAL PLANT (CTP) STAGE 2 STRATUM LOT.
- LOT 203 - BREWERY YARD STRATUM LOT
- LOT 204 - PUBLIC ROAD STRATUM LOT
- LOT 205 - OPEN SPACE STRATUM LOT
- LOT 206 - BLOCK 4S RETAIL STRATUM LOT
- LOT 207 - 'PUB' STRATUM LOT
- LOT 208 - 'TERRACE' STRATUM LOT
- LOT 209 - BLOCK 1 RESIDENTIAL STRATUM LOT
- LOT 210 - BLOCK 1 RETAIL STRATUM LOT
- LOT 211 - BLOCK 4N HOTEL STRATUM LOT
- LOT 212 - BLOCK 4N COMMERCIAL STRATUM LOT
- LOT 213 - BLOCK 4N CHILDCARE STRATUM LOT
- LOT 214 - BREWERY YARD PARKING STRATUM LOT
- LOT 215 - BLOCK 4N RESIDENTIAL STRATUM LOT

Surveyor: TASY MORAITIS
Date of Survey:
Surveyor's Ref: 080401 SL2 SUB

PLAN OF SUBDIVISION OF LOT 200 & 201 IN
D.P. 1212253 AND LOT 1 IN D.P. 807298

SUBDIVISION OF BLOCK 1, BLOCK 1 NORTH,
BLOCK 4 SOUTH AND
BREWERY YARD IN 2 STAGES

LGA: SYDNEY
Locality: CHIPPENDALE
Subdivision No:
Lengths are in metres. Reduction Ratio 1:500

REGISTERED
CONTRACT PLAN
Plan compiled from
architectural CAD data.
Plan is subject to final
survey after completion
of construction.

DRAFT
PRINTED 18 NOV 2016
ISSUE 14
STAGE 4

BLOCK 4N HOTEL LEVELS 14-18
BLOCK 4N RESEDENTIAL EVELS 12-16
BLOCK 1 LEVELS 14 - 18
BLOCK 4S LEVELS 15 & ABOVE



STREET

ABERCROMBIE

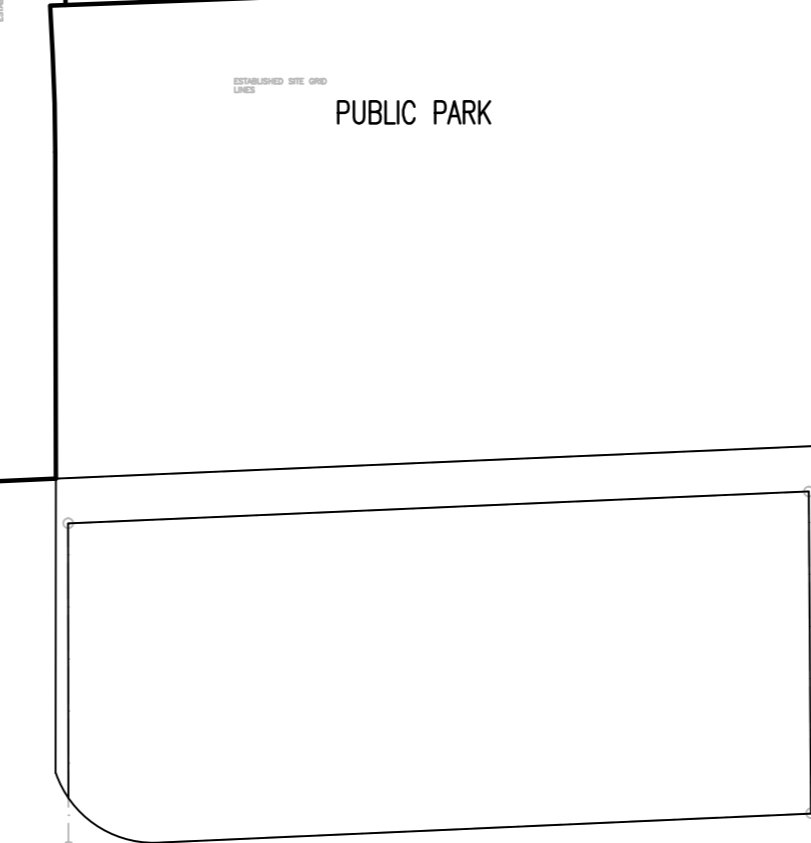
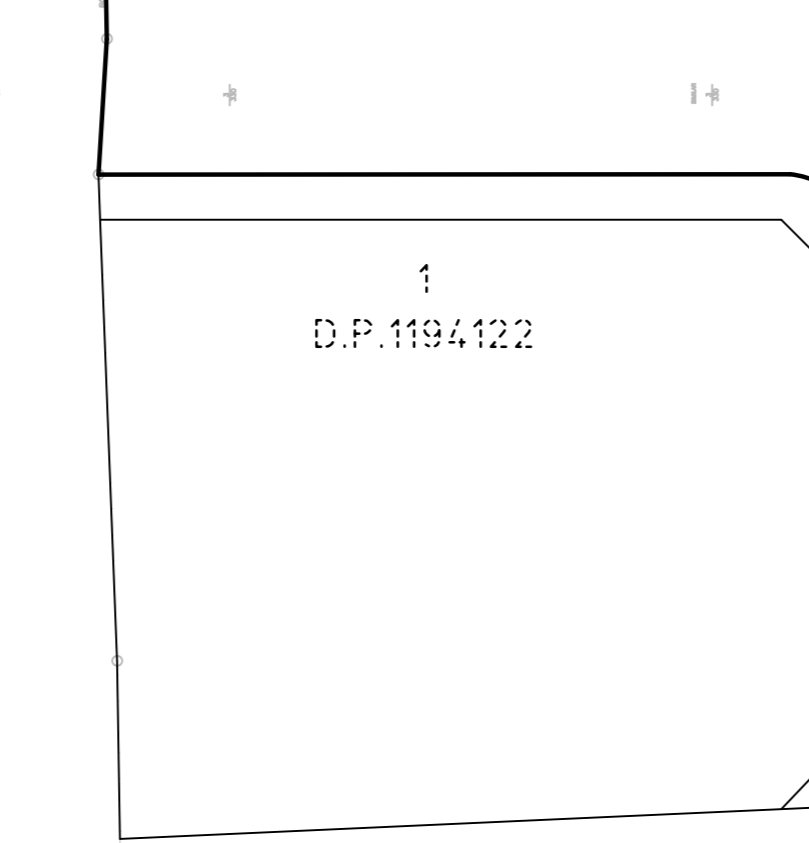
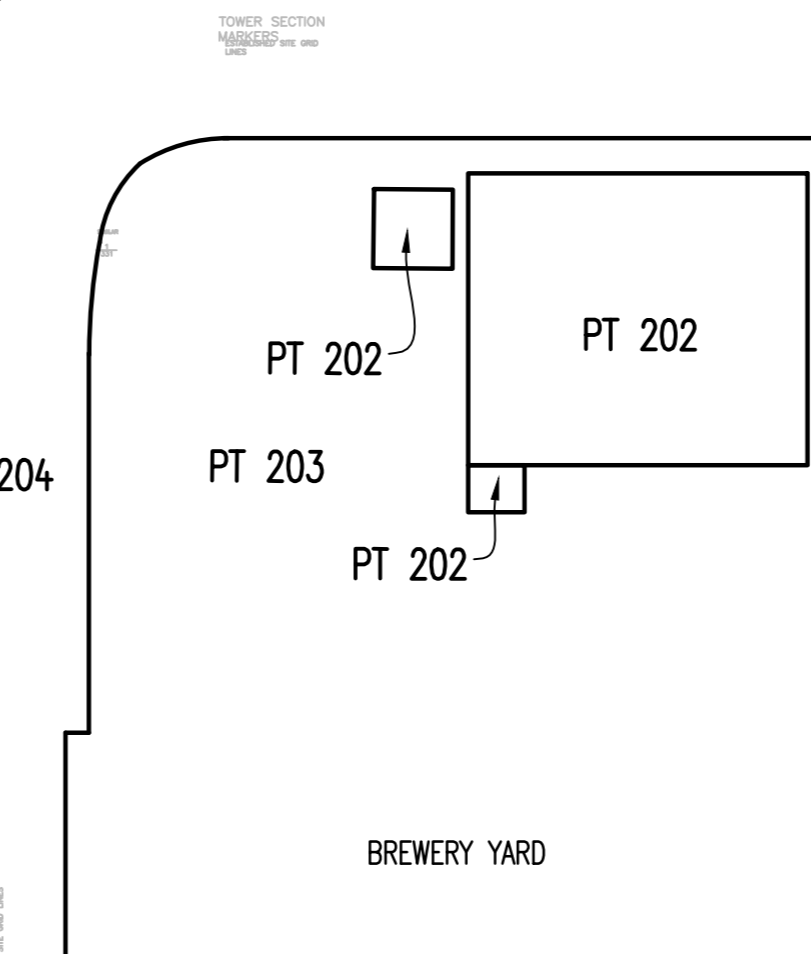
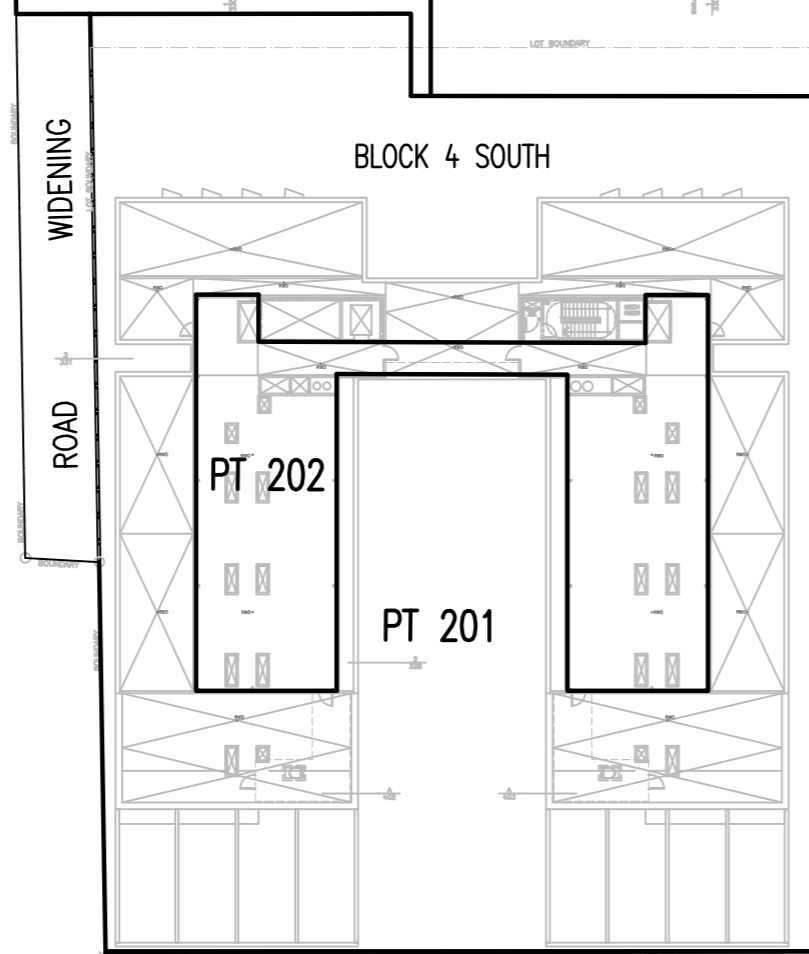
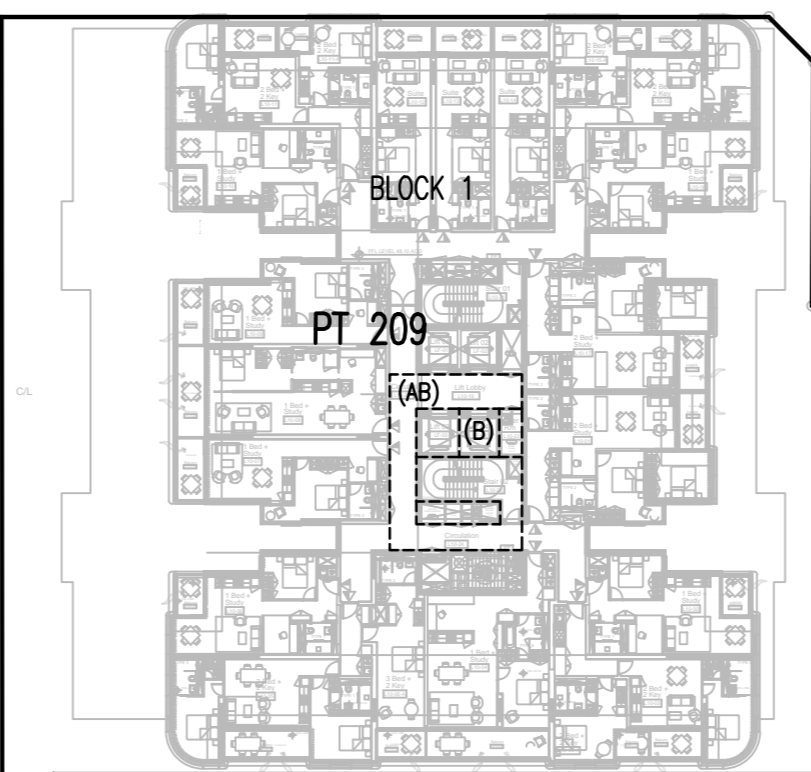
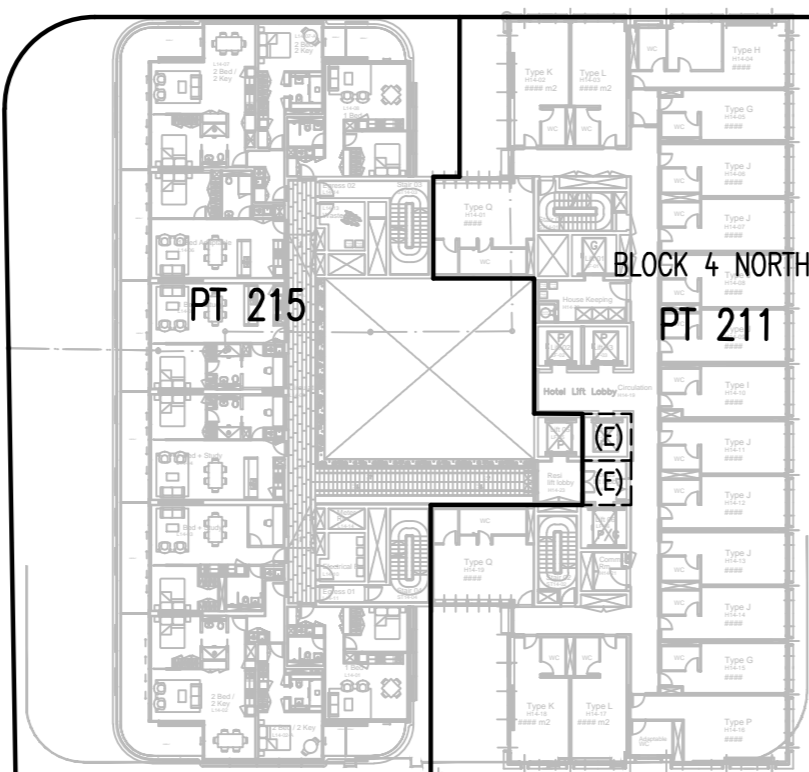

CHIPPENDALE WAY

- (AB) - EASEMENT FOR ROOF ACCESS VARIABLE WIDTH (LIMITED IN STRATUM)
- (B) - EASEMENT TO ACCESS AND USE LIFTS VARIABLE WIDTH (LIMITED IN STRATUM)
- (E) - EASEMENT TO ACCESS AND USE LIFTS VARIABLE WIDTH (LIMITED IN STRATUM)

D.P. 1181334

- WHOLE OF LOT EASEMENTS AFFECTING LOTS 201, 202, 203, 206, 209, 210, 211, 212, 213, 214 & 215
- EASEMENT FOR SUPPORT AND SHELTER
 - EASEMENT TO SERVICES
 - EASEMENT FOR FIRE STAIRS & PASSAGES
 - EASEMENT TO ACCESS FACILITIES

SCHEDULE OF STRATUM LOTS WITHIN STAGES 1 & 2

STAGE 1 LOTS

- LOT 201 - BLOCK 4S STUDENT ACCOMMODATION STRATUM LOT
- LOT 202 - CENTRAL THERMAL PLANT (CTP) STAGE 2 STRATUM LOT.
- LOT 203 - BREWERY YARD STRATUM LOT
- LOT 204 - PUBLIC ROAD STRATUM LOT
- LOT 205 - OPEN SPACE STRATUM LOT
- LOT 206 - BLOCK 4S RETAIL STRATUM LOT
- LOT 207 - 'PUB' STRATUM LOT
- LOT 208 - 'TERRACE' STRATUM LOT
- LOT 209 - BLOCK 1 RESIDENTIAL STRATUM LOT
- LOT 210 - BLOCK 1 RETAIL STRATUM LOT
- LOT 211 - BLOCK 4N HOTEL STRATUM LOT
- LOT 212 - BLOCK 4N COMMERCIAL STRATUM LOT
- LOT 213 - BLOCK 4N CHILDCARE STRATUM LOT
- LOT 214 - BREWERY YARD PARKING STRATUM LOT
- LOT 215 - BLOCK 4N RESIDENTIAL STRATUM LOT

Surveyor: TASY MORAITIS
 Date of Survey:
 Surveyor's Ref: 080401 SL2 SUB

PLAN OF SUBDIVISION OF LOT 200 & 201 IN
 D.P. 1212253 AND LOT 1 IN D.P. 807298
 SUBDIVISION OF BLOCK 1, BLOCK 1 NORTH,
 BLOCK 4 SOUTH AND
 BREWERY YARD IN 2 STAGES

LGA: SYDNEY
 Locality: CHIPPENDALE
 Subdivision No:
 Lengths are in metres. Reduction Ratio 1:500

REGISTERED
 CONTRACT PLAN
 Plan compiled from
 architectural CAD data.
 Plan is subject to final
 survey after completion
 of construction.

DRAFT
 PRINTED 18 NOV 2016
 ISSUE 14
 STAGE 4

LEVEL 19



STREET

ABERCROMBIE

ROAD WIDENING

BROADWAY

CHIPPENDALE WAY

D.P.1181334

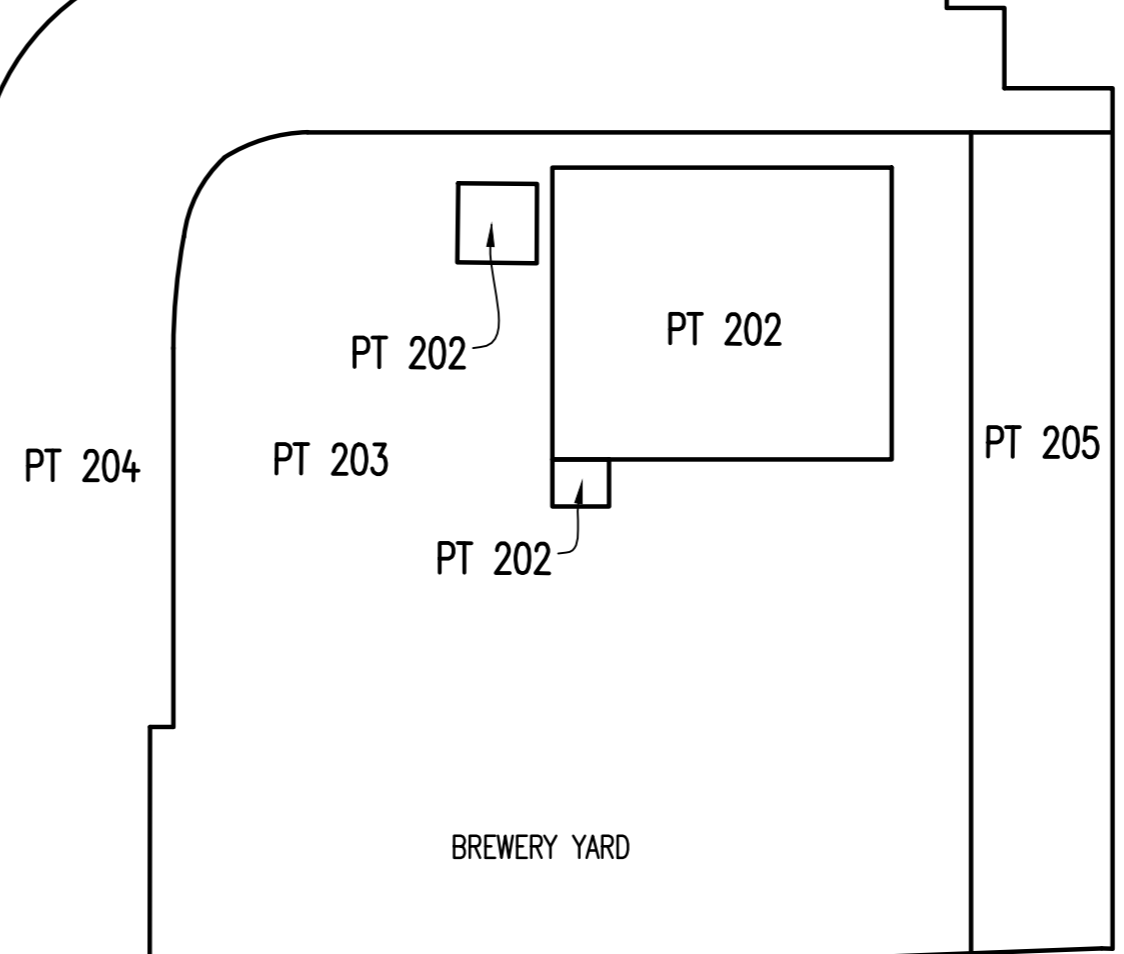
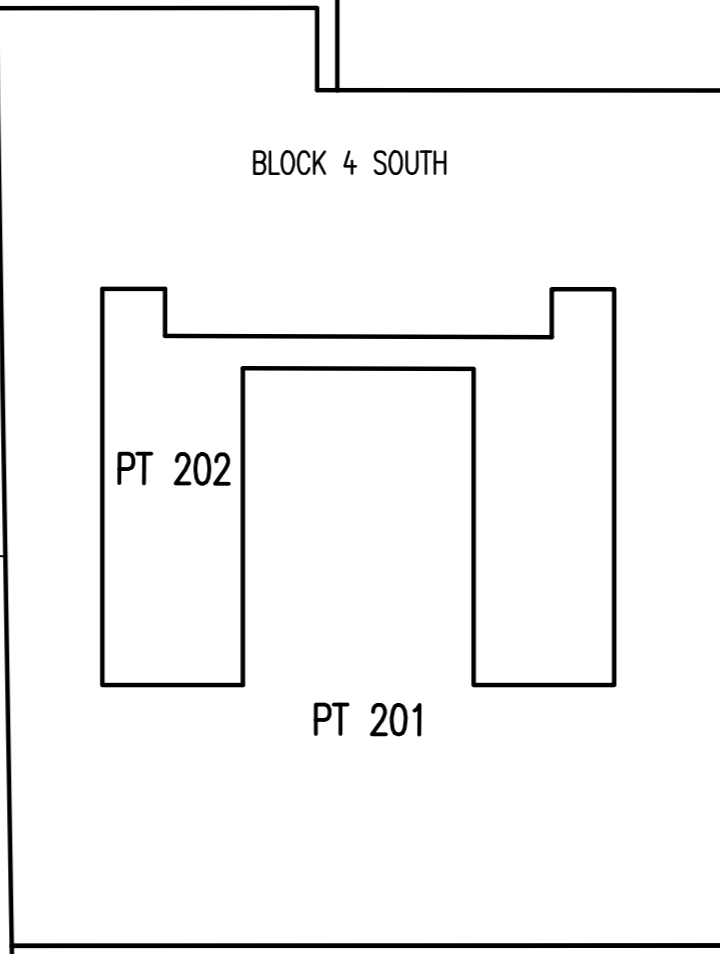
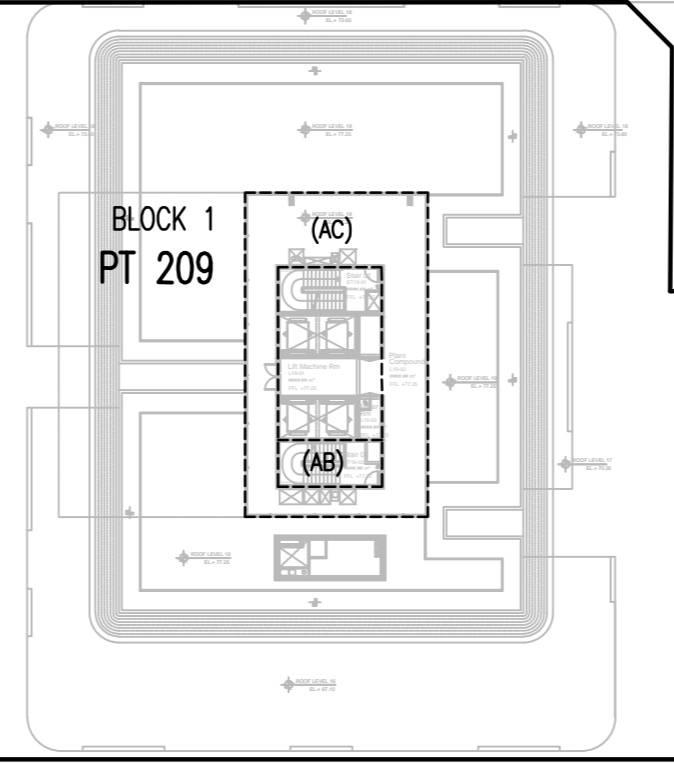
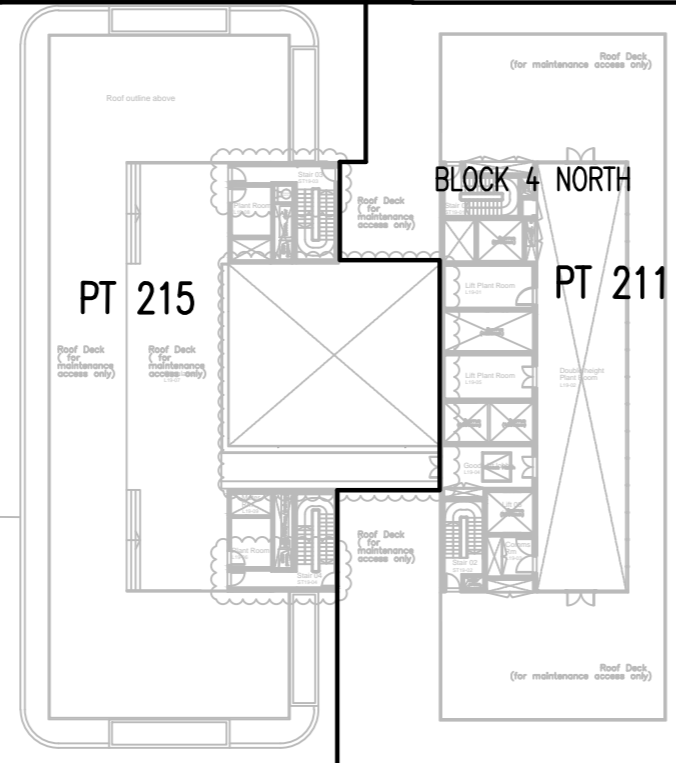

- WHOLE OF LOT EASEMENTS AFFECTING LOTS 201, 202, 203, 206, 209, 210, 211, 212, 213, 214 & 215
- EASEMENT FOR SUPPORT AND SHELTER
 - EASEMENT TO SERVICES
 - EASEMENT FOR FIRE STAIRS & PASSAGES
 - EASEMENT TO ACCESS FACILITIES

SCHEDULE OF STRATUM LOTS WITHIN STAGES 1 & 2

- STAGE 1 LOTS
- LOT 201 - BLOCK 4S STUDENT ACCOMMODATION STRATUM LOT
 - LOT 202 - CENTRAL THERMAL PLANT (CTP) STAGE 2 STRATUM LOT.
 - LOT 203 - BREWERY YARD STRATUM LOT
 - LOT 204 - PUBLIC ROAD STRATUM LOT
 - LOT 205 - OPEN SPACE STRATUM LOT
 - LOT 206 - BLOCK 4S RETAIL STRATUM LOT
 - LOT 207 - 'PUB' STRATUM LOT
 - LOT 208 - 'TERRACE' STRATUM LOT
 - LOT 209 - BLOCK 1 RESIDENTIAL STRATUM LOT
 - LOT 210 - BLOCK 1 RETAIL STRATUM LOT
 - LOT 211 - BLOCK 4N HOTEL STRATUM LOT
 - LOT 212 - BLOCK 4N COMMERCIAL STRATUM LOT
 - LOT 213 - BLOCK 4N CHILDCARE STRATUM LOT
 - LOT 214 - BREWERY YARD PARKING STRATUM LOT
 - LOT 215 - BLOCK 4N RESIDENTIAL STRATUM LOT

- (AB) - EASEMENT FOR ROOF ACCESS VARIABLE WIDTH (LIMITED IN STRATUM)
- (AC) - EASEMENT FOR KITCHEN EXHAUST PURPOSES VARIABLE WIDTH (LIMITED IN STRATUM)

1
D.P.1194122

Surveyor: TASY MORAITIS
 Date of Survey:
 Surveyor's Ref: 080401 SL2 SUB

PLAN OF SUBDIVISION OF LOT 200 & 201 IN D.P. 1212253 AND LOT 1 IN D.P. 807298

SUBDIVISION OF BLOCK 1, BLOCK 1 NORTH, BLOCK 4 SOUTH AND BREWERY YARD IN 2 STAGES

LGA: SYDNEY
 Locality: CHIPPENDALE
 Subdivision No:
 Lengths are in metres. Reduction Ratio 1:500

REGISTERED CONTRACT PLAN
 Plan compiled from architectural CAD data.
 Plan is subject to final survey after completion of construction.

DRAFT
 PRINTED 18 NOV 2016
 ISSUE 14
 STAGE 4

ROOF LEVEL
LEVEL 20 & ABOVE



ABERCROMBIE

STREET

ROAD
WIDENING

BROADWAY

CHIPPENDALE
WAY

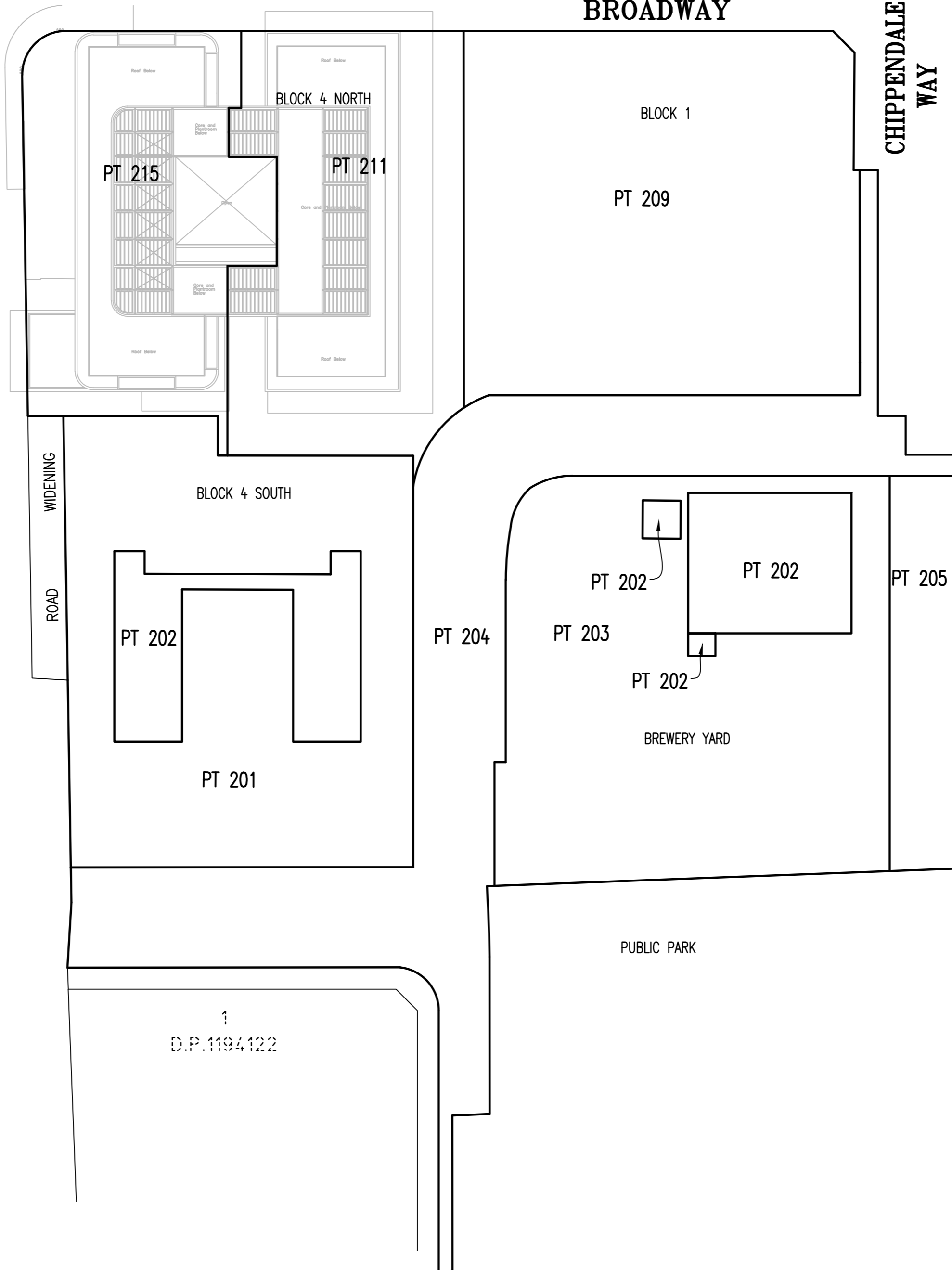

D.P.1181334

WHOLE OF LOT EASEMENTS AFFECTING LOTS 201, 202, 203, 206, 209, 210, 211, 212, 213, 214 & 215

- EASEMENT FOR SUPPORT AND SHELTER
- EASEMENT TO SERVICES
- EASEMENT FOR FIRE STAIRS & PASSAGES
- EASEMENT TO ACCESS FACILITIES

SCHEDULE OF STRATUM LOTS WITHIN STAGES 1 & 2

STAGE 1 LOTS

- LOT 201 - BLOCK 4S STUDENT ACCOMMODATION STRATUM LOT
- LOT 202 - CENTRAL THERMAL PLANT (CTP) STAGE 2 STRATUM LOT.
- LOT 203 - BREWERY YARD STRATUM LOT
- LOT 204 - PUBLIC ROAD STRATUM LOT
- LOT 205 - OPEN SPACE STRATUM LOT
- LOT 206 - BLOCK 4S RETAIL STRATUM LOT
- LOT 207 - 'PUB' STRATUM LOT
- LOT 208 - 'TERRACE' STRATUM LOT
- LOT 209 - BLOCK 1 RESIDENTIAL STRATUM LOT
- LOT 210 - BLOCK 1 RETAIL STRATUM LOT
- LOT 211 - BLOCK 4N HOTEL STRATUM LOT
- LOT 212 - BLOCK 4N COMMERCIAL STRATUM LOT
- LOT 213 - BLOCK 4N CHILDCARE STRATUM LOT
- LOT 214 - BREWERY YARD PARKING STRATUM LOT
- LOT 215 - BLOCK 4N RESIDENTIAL STRATUM LOT

1
D.P.1194122

Surveyor: TASY MORAITIS
 Date of Survey:
 Surveyor's Ref: 080401 SL2 SUB

PLAN OF SUBDIVISION OF LOT 200 & 201 IN
 D.P. 1212253 AND LOT 1 IN D.P. 807298

SUBDIVISION OF BLOCK 1, BLOCK 1 NORTH,
 BLOCK 4 SOUTH AND
 BREWERY YARD IN 2 STAGES

LGA: SYDNEY
 Locality: CHIPPENDALE
 Subdivision No:
 Lengths are in metres. Reduction Ratio 1:500

REGISTERED
 CONTRACT PLAN
 Plan compiled from
 architectural CAD data.
 Plan is subject to final
 survey after completion
 of construction.

DRAFT
 PRINTED 18 NOV 2016
 ISSUE 14
 STAGE 4