

LEVEL 2

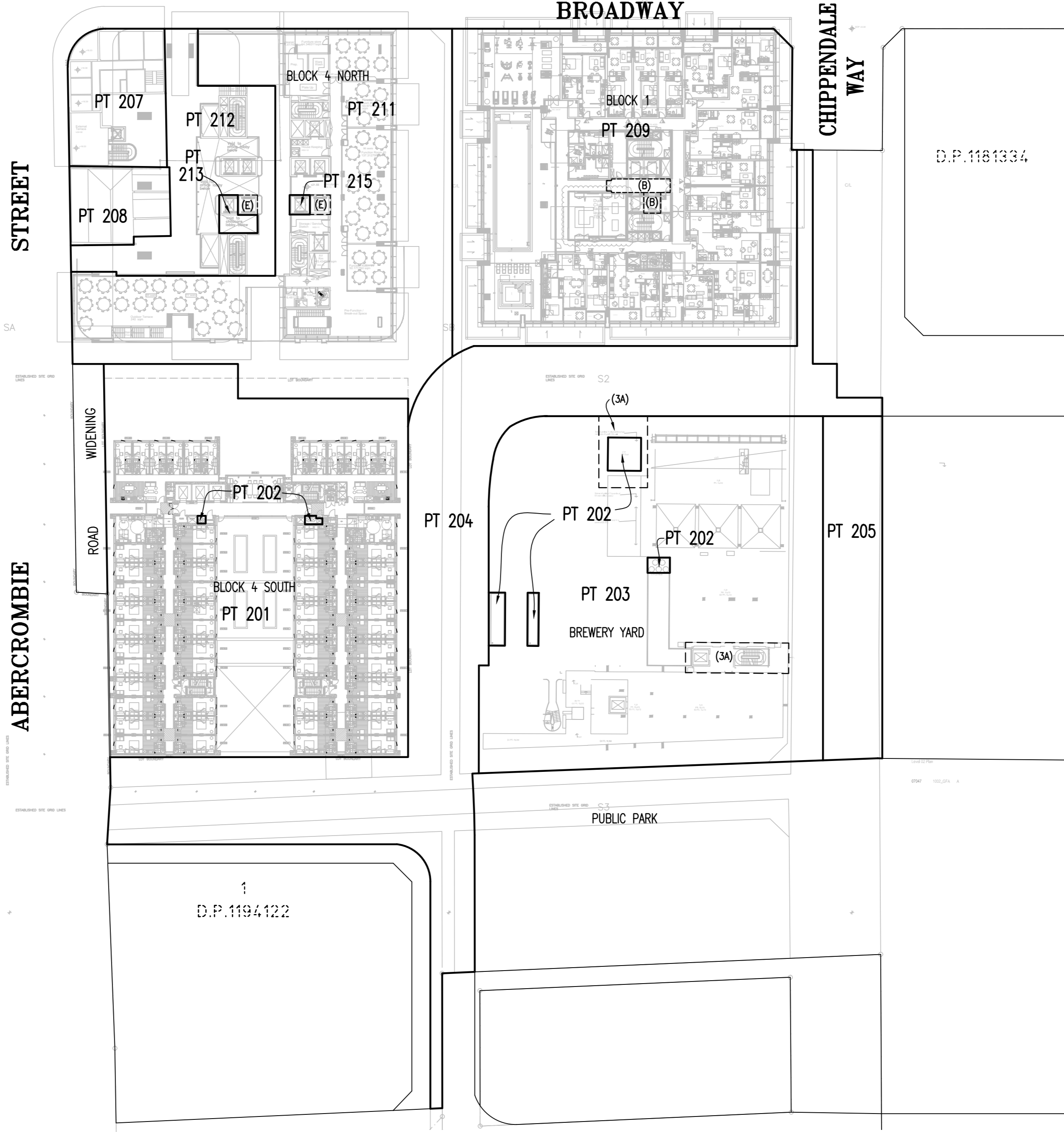

D.P.1181334

PROPOSED EASEMENTS WITH RESPECT TO LOT 203

- (3A) - EASEMENT TO ACCESS AND MAINTAIN CTP TOWER INFRASTRUCTURE
- (B) - EASEMENT TO ACCESS AND USE LIFTS VARIABLE WIDTH (LIMITED IN STRATUM)
- (E) - EASEMENT TO ACCESS AND USE LIFTS VARIABLE WIDTH (LIMITED IN STRATUM)

- WHOLE OF LOT EASEMENTS AFFECTING LOTS 201, 202, 203, 206, 209, 210, 211, 212, 213, 214 & 215
- EASEMENT FOR SUPPORT AND SHELTER
 - EASEMENT TO SERVICES
 - EASEMENT FOR FIRE STAIRS & PASSAGES
 - EASEMENT TO ACCESS FACILITIES

SCHEDULE OF STRATUM LOTS WITHIN STAGES 1 & 2

STAGE 1 LOTS

- LOT 201 - BLOCK 4S STUDENT ACCOMMODATION STRATUM LOT
- LOT 202 - CENTRAL THERMAL PLANT (CTP) STAGE 2 STRATUM LOT.
- LOT 203 - BREWERY YARD STRATUM LOT
- LOT 204 - PUBLIC ROAD STRATUM LOT
- LOT 205 - OPEN SPACE STRATUM LOT
- LOT 206 - BLOCK 4S RETAIL STRATUM LOT
- LOT 207 - 'PUB' STRATUM LOT
- LOT 208 - 'TERRACE' STRATUM LOT
- LOT 209 - BLOCK 1 RESIDENTIAL STRATUM LOT
- LOT 210 - BLOCK 1 RETAIL STRATUM LOT
- LOT 211 - BLOCK 4N HOTEL STRATUM LOT
- LOT 212 - BLOCK 4N COMMERCIAL STRATUM LOT
- LOT 213 - BLOCK 4N CHILDCARE STRATUM LOT
- LOT 214 - BREWERY YARD PARKING STRATUM LOT
- LOT 215 - BLOCK 4N RESIDENTIAL STRATUM LOT

Surveyor: TASY MORAITIS
 Date of Survey:
 Surveyor's Ref: 080401 SL2 SUB

PLAN OF SUBDIVISION OF LOT 200 & 201 IN D.P. 1212253 AND LOT 1 IN D.P. 807298
 SUBDIVISION OF BLOCK 1, BLOCK 1 NORTH, BLOCK 4 SOUTH AND BREWERY YARD IN 2 STAGES

LGA: SYDNEY
 Locality: CHIPPENDALE
 Subdivision No:
 Lengths are in metres. Reduction Ratio 1:500

REGISTERED CONTRACT PLAN
 Plan compiled from architectural CAD data.
 Plan is subject to final survey after completion of construction.

DRAFT
 PRINTED 14 MAR 2017
 ISSUE 16
 STAGE 4

LEVEL 3



STREET

ABERCROMBIE

BROADWAY

CHIPPENDALE WAY

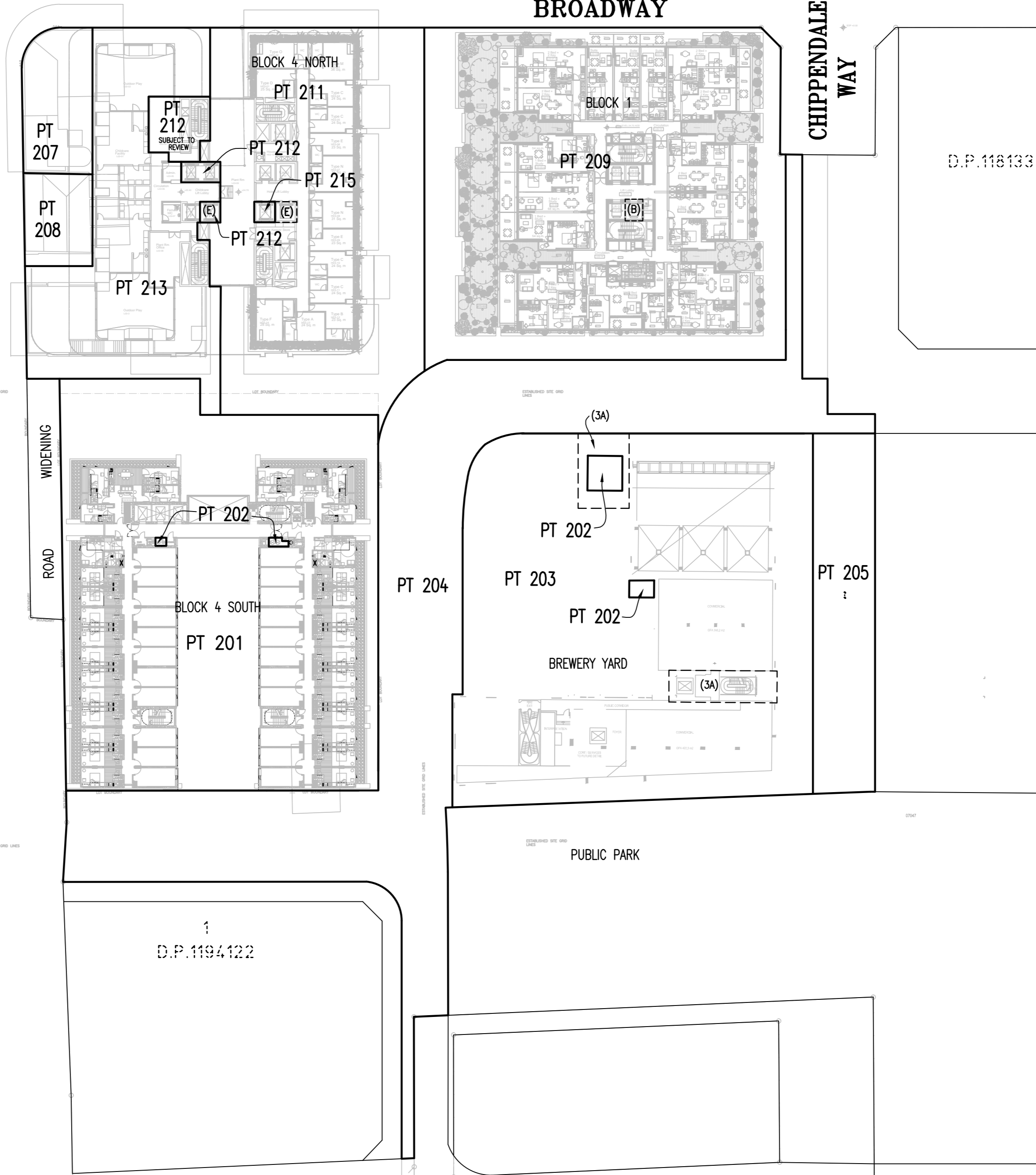

D.P.1181334

PROPOSED EASEMENTS WITH RESPECT TO LOT 203

- (3A) - EASEMENT TO ACCESS AND MAINTAIN CTP TOWER INFRASTRUCTURE
- (B) - EASEMENT TO ACCESS AND USE LIFTS VARIABLE WIDTH (LIMITED IN STRATUM)
- (E) - EASEMENT TO ACCESS AND USE LIFTS VARIABLE WIDTH (LIMITED IN STRATUM)

WHOLE OF LOT EASEMENTS AFFECTING LOTS 201, 202, 203, 206, 209, 210, 211, 212, 213, 214 & 215

- EASEMENT FOR SUPPORT AND SHELTER
- EASEMENT TO SERVICES
- EASEMENT FOR FIRE STAIRS & PASSAGES
- EASEMENT TO ACCESS FACILITIES

SCHEDULE OF STRATUM LOTS WITHIN STAGES 1 & 2

STAGE 1 LOTS

- LOT 201 - BLOCK 4S STUDENT ACCOMMODATION STRATUM LOT
- LOT 202 - CENTRAL THERMAL PLANT (CTP) STAGE 2 STRATUM LOT.
- LOT 203 - BREWERY YARD STRATUM LOT
- LOT 204 - PUBLIC ROAD STRATUM LOT
- LOT 205 - OPEN SPACE STRATUM LOT
- LOT 206 - BLOCK 4S RETAIL STRATUM LOT
- LOT 207 - 'PUB' STRATUM LOT
- LOT 208 - 'TERRACE' STRATUM LOT
- LOT 209 - BLOCK 1 RESIDENTIAL STRATUM LOT
- LOT 210 - BLOCK 1 RETAIL STRATUM LOT
- LOT 211 - BLOCK 4N HOTEL STRATUM LOT
- LOT 212 - BLOCK 4N COMMERCIAL STRATUM LOT
- LOT 213 - BLOCK 4N CHILDCARE STRATUM LOT
- LOT 214 - BREWERY YARD PARKING STRATUM LOT
- LOT 215 - BLOCK 4N RESIDENTIAL STRATUM LOT

D.P.1194122

Surveyor: TASY MORAITIS
 Date of Survey:
 Surveyor's Ref: 080401 SL2 SUB

PLAN OF SUBDIVISION OF LOT 200 & 201 IN D.P. 1212253 AND LOT 1 IN D.P. 807298

SUBDIVISION OF BLOCK 1, BLOCK 1 NORTH, BLOCK 4 SOUTH AND BREWERY YARD IN 2 STAGES

LGA: SYDNEY
 Locality: CHIPPENDALE
 Subdivision No:
 Lengths are in metres. Reduction Ratio 1:500

REGISTERED CONTRACT PLAN
 Plan compiled from architectural CAD data.
 Plan is subject to final survey after completion of construction.

DRAFT
 PRINTED 14 MAR 2017
 ISSUE 16
 STAGE 4

LEVEL 4



STREET

ABERCROMBIE

ROAD
WIDENING

BROADWAY

CHIPPENDALE
WAY

D.P. 1181334

PROPOSED EASEMENTS WITH RESPECT TO LOT 203

- (3A) - EASEMENT TO ACCESS AND MAINTAIN CTP TOWER INFRASTRUCTURE
- (B) - EASEMENT TO ACCESS AND USE LIFTS VARIABLE WIDTH (LIMITED IN STRATUM)
- (E) - EASEMENT TO ACCESS AND USE LIFTS VARIABLE WIDTH (LIMITED IN STRATUM)

WHOLE OF LOT EASEMENTS AFFECTING LOTS 201, 202, 203, 206, 209, 210, 211, 212, 213, 214 & 215

- EASEMENT FOR SUPPORT AND SHELTER
- EASEMENT TO SERVICES
- EASEMENT FOR FIRE STAIRS & PASSAGES
- EASEMENT TO ACCESS FACILITIES

SCHEDULE OF STRATUM LOTS WITHIN STAGES 1 & 2

STAGE 1 LOTS

- LOT 201 - BLOCK 4S STUDENT ACCOMMODATION STRATUM LOT
- LOT 202 - CENTRAL THERMAL PLANT (CTP) STAGE 2 STRATUM LOT.
- LOT 203 - BREWERY YARD STRATUM LOT
- LOT 204 - PUBLIC ROAD STRATUM LOT
- LOT 205 - OPEN SPACE STRATUM LOT
- LOT 206 - BLOCK 4S RETAIL STRATUM LOT
- LOT 207 - 'PUB' STRATUM LOT
- LOT 208 - 'TERRACE' STRATUM LOT
- LOT 209 - BLOCK 1 RESIDENTIAL STRATUM LOT
- LOT 210 - BLOCK 1 RETAIL STRATUM LOT
- LOT 211 - BLOCK 4N HOTEL STRATUM LOT
- LOT 212 - BLOCK 4N COMMERCIAL STRATUM LOT
- LOT 213 - BLOCK 4N CHILDCARE STRATUM LOT
- LOT 214 - BREWERY YARD PARKING STRATUM LOT
- LOT 215 - BLOCK 4N RESIDENTIAL STRATUM LOT

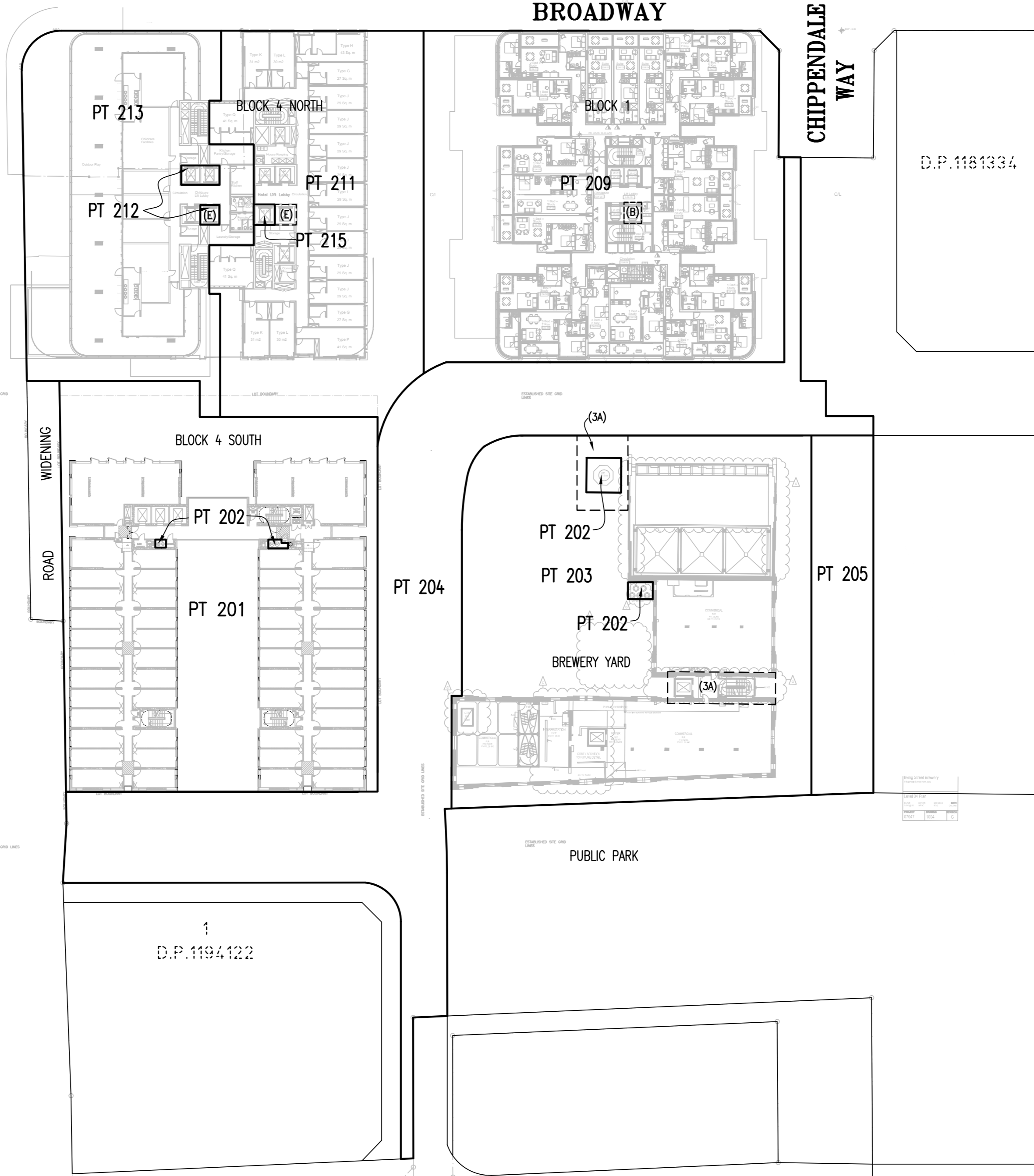

Surveyor: TASY MORAITIS
 Date of Survey:
 Surveyor's Ref: 080401 SL2 SUB

PLAN OF SUBDIVISION OF LOT 200 & 201 IN
 D.P. 1212253 AND LOT 1 IN D.P. 807298
 SUBDIVISION OF BLOCK 1, BLOCK 1 NORTH,
 BLOCK 4 SOUTH AND
 BREWERY YARD IN 2 STAGES

LGA: SYDNEY
 Locality: CHIPPENDALE
 Subdivision No:
 Lengths are in metres. Reduction Ratio 1: 500

REGISTERED
 CONTRACT PLAN
 Plan compiled from
 architectural CAD data.
 Plan is subject to final
 survey after completion
 of construction.

DRAFT
 PRINTED 14 MAR 2017
 ISSUE 16
 STAGE 4

LEVEL 5



STREET

ABERCROMBIE

BROADWAY

CHIPPENDALE WAY

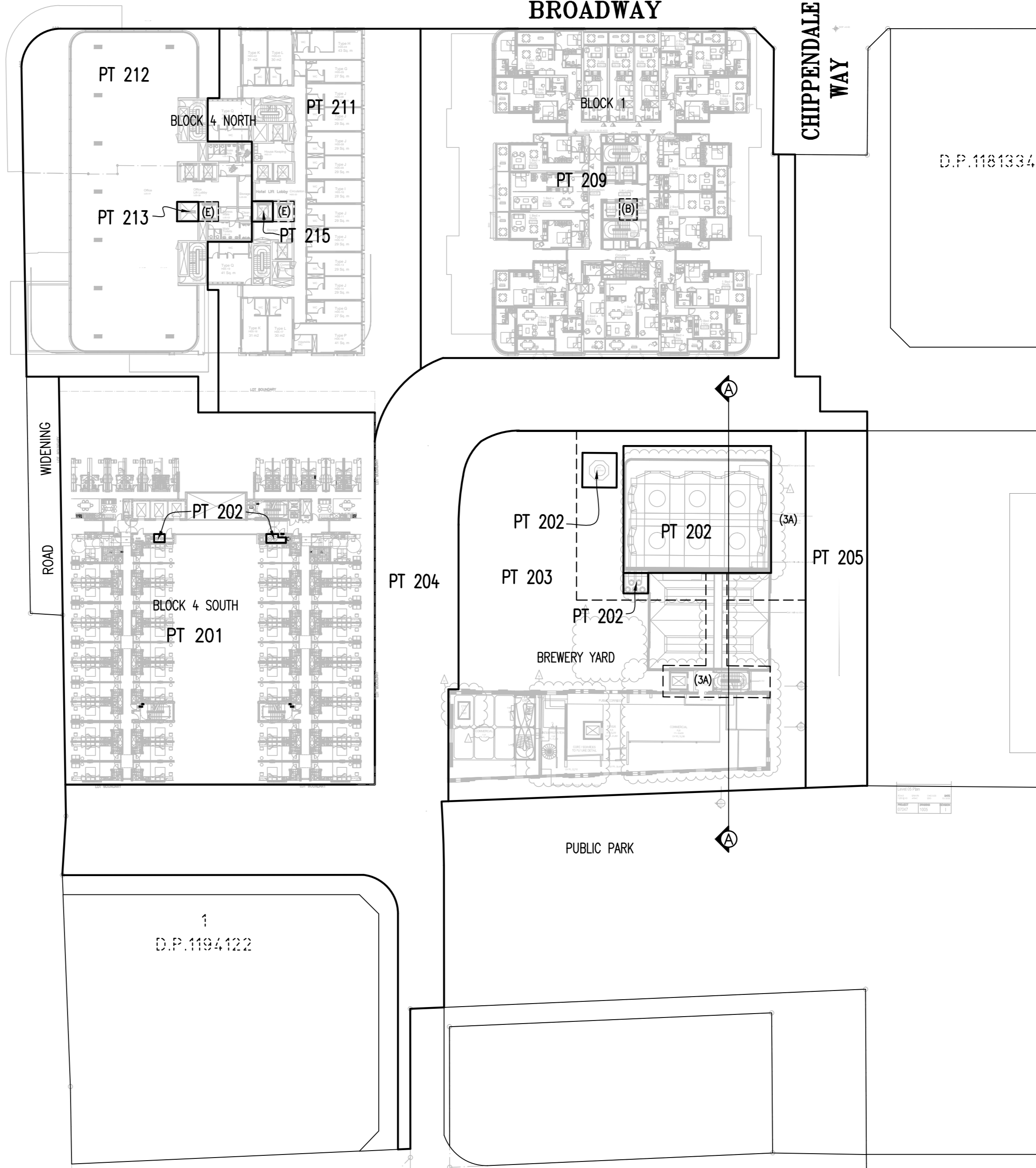

D.P.1181334

PROPOSED EASEMENTS WITH RESPECT TO LOT 203

- (3A) - EASEMENT TO ACCESS AND MAINTAIN CTP TOWER INFRASTRUCTURE
- (B) - EASEMENT TO ACCESS AND USE LIFTS VARIABLE WIDTH (LIMITED IN STRATUM)
- (E) - EASEMENT TO ACCESS AND USE LIFTS VARIABLE WIDTH (LIMITED IN STRATUM)

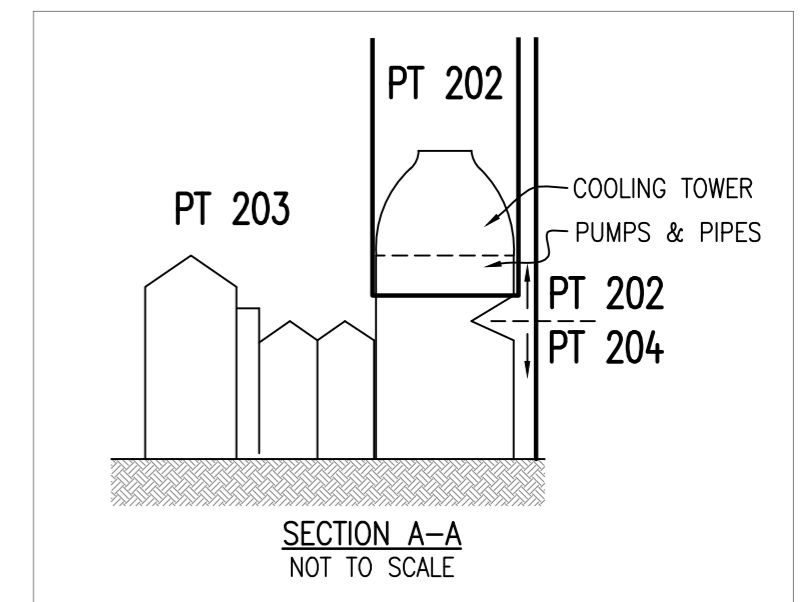

WHOLE OF LOT EASEMENTS AFFECTING LOTS 201, 202, 203, 206, 209, 210, 211, 212, 213, 214 & 215

- EASEMENT FOR SUPPORT AND SHELTER
- EASEMENT TO SERVICES
- EASEMENT FOR FIRE STAIRS & PASSAGES
- EASEMENT TO ACCESS FACILITIES

SCHEDULE OF STRATUM LOTS WITHIN STAGES 1 & 2

STAGE 1 LOTS

- LOT 201 - BLOCK 4S STUDENT ACCOMMODATION STRATUM LOT
- LOT 202 - CENTRAL THERMAL PLANT (CTP) STAGE 2 STRATUM LOT.
- LOT 203 - BREWERY YARD STRATUM LOT
- LOT 204 - PUBLIC ROAD STRATUM LOT
- LOT 205 - OPEN SPACE STRATUM LOT
- LOT 206 - BLOCK 4S RETAIL STRATUM LOT
- LOT 207 - 'PUB' STRATUM LOT
- LOT 208 - 'TERRACE' STRATUM LOT
- LOT 209 - BLOCK 1 RESIDENTIAL STRATUM LOT
- LOT 210 - BLOCK 1 RETAIL STRATUM LOT
- LOT 211 - BLOCK 4N HOTEL STRATUM LOT
- LOT 212 - BLOCK 4N COMMERCIAL STRATUM LOT
- LOT 213 - BLOCK 4N CHILDCARE STRATUM LOT
- LOT 214 - BREWERY YARD PARKING STRATUM LOT
- LOT 215 - BLOCK 4N RESIDENTIAL STRATUM LOT

D.P.1194122

Surveyor: TASY MORAITIS
 Date of Survey:
 Surveyor's Ref: 080401 SL2 SUB

PLAN OF SUBDIVISION OF LOT 200 & 201 IN
 D.P. 1212253 AND LOT 1 IN D.P. 807298

SUBDIVISION OF BLOCK 1, BLOCK 1 NORTH,
 BLOCK 4 SOUTH AND
 BREWERY YARD IN 2 STAGES

LGA: SYDNEY
 Locality: CHIPPENDALE
 Subdivision No:
 Lengths are in metres. Reduction Ratio 1:500

REGISTERED
 CONTRACT PLAN
 Plan compiled from
 architectural CAD data.
 Plan is subject to final
 survey after completion
 of construction.

DRAFT
 PRINTED 14 MAR 2017
 ISSUE 16
 STAGE 4

LEVEL 6



STREET

BROADWAY

CHIPPENDALE WAY

ABERCROMBIE

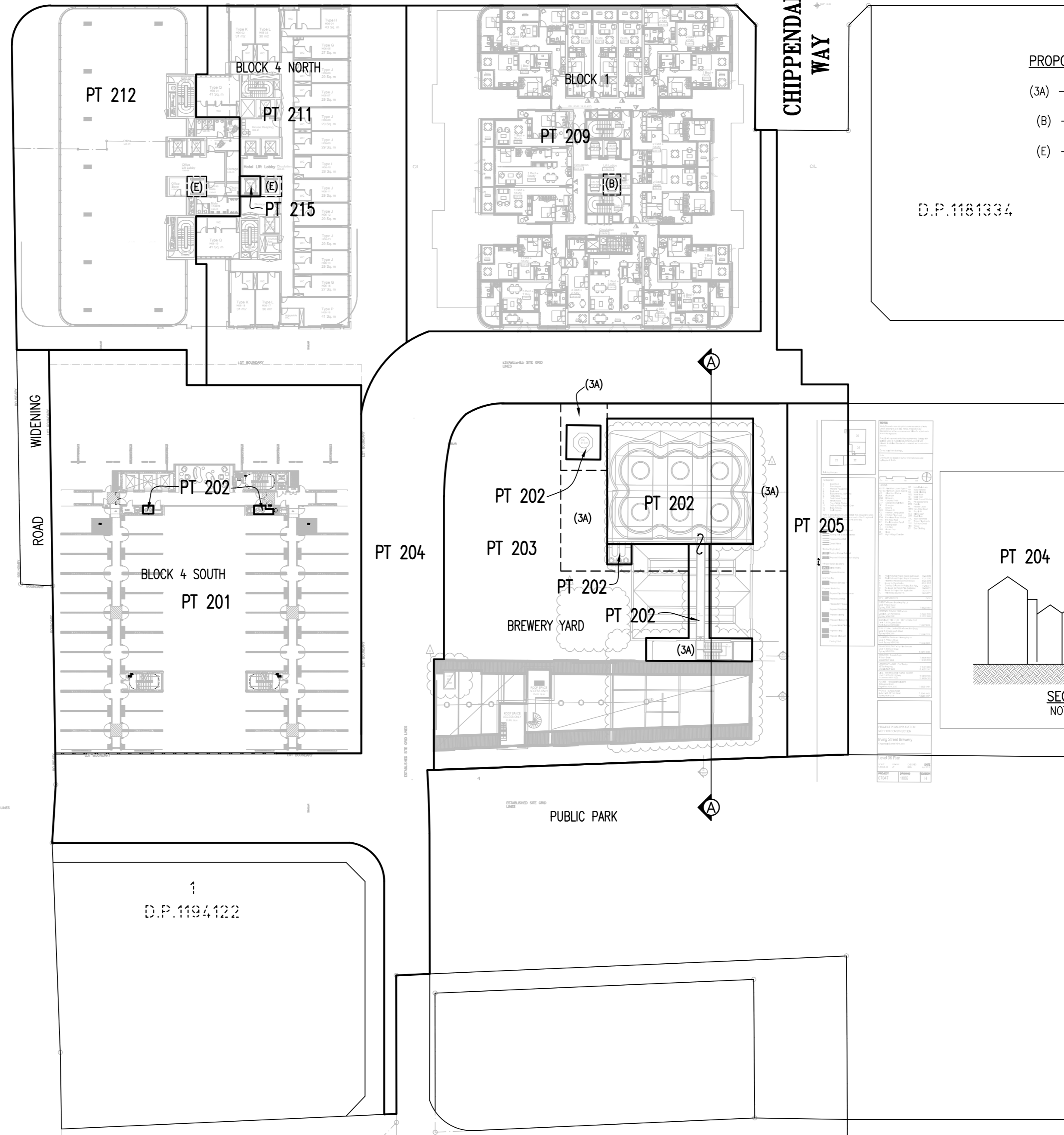

PROPOSED EASEMENTS WITH RESPECT TO LOT 203

- (3A) - EASEMENT TO ACCESS AND MAINTAIN CTP TOWER INFRASTRUCTURE
- (B) - EASEMENT TO ACCESS AND USE LIFTS VARIABLE WIDTH (LIMITED IN STRATUM)
- (E) - EASEMENT TO ACCESS AND USE LIFTS VARIABLE WIDTH (LIMITED IN STRATUM)

D.P.1181334

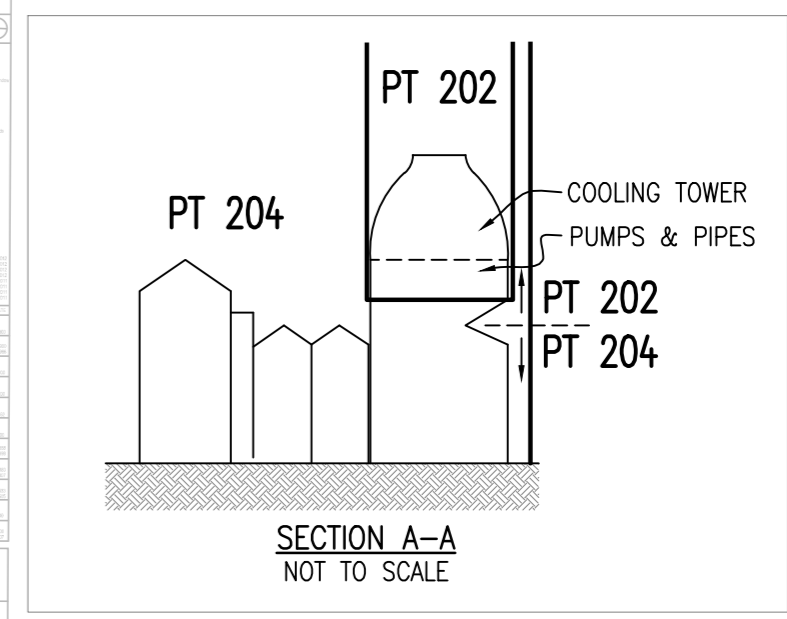

- WHOLE OF LOT EASEMENTS AFFECTING LOTS 201, 202, 203, 206, 209, 210, 211, 212, 213, 214 & 215
- EASEMENT FOR SUPPORT AND SHELTER
 - EASEMENT TO SERVICES
 - EASEMENT FOR FIRE STAIRS & PASSAGES
 - EASEMENT TO ACCESS FACILITIES

SCHEDULE OF STRATUM LOTS WITHIN STAGES 1 & 2

- STAGE 1 LOTS
- LOT 201 - BLOCK 4S STUDENT ACCOMMODATION STRATUM LOT
 - LOT 202 - CENTRAL THERMAL PLANT (CTP) STAGE 2 STRATUM LOT.
 - LOT 203 - BREWERY YARD STRATUM LOT
 - LOT 204 - PUBLIC ROAD STRATUM LOT
 - LOT 205 - OPEN SPACE STRATUM LOT
 - LOT 206 - BLOCK 4S RETAIL STRATUM LOT
 - LOT 207 - 'PUB' STRATUM LOT
 - LOT 208 - 'TERRACE' STRATUM LOT
 - LOT 209 - BLOCK 1 RESIDENTIAL STRATUM LOT
 - LOT 210 - BLOCK 1 RETAIL STRATUM LOT
 - LOT 211 - BLOCK 4N HOTEL STRATUM LOT
 - LOT 212 - BLOCK 4N COMMERCIAL STRATUM LOT
 - LOT 213 - BLOCK 4N CHILDCARE STRATUM LOT
 - LOT 214 - BREWERY YARD PARKING STRATUM LOT
 - LOT 215 - BLOCK 4N RESIDENTIAL STRATUM LOT

Surveyor: TASY MORAITIS
 Date of Survey:
 Surveyor's Ref: 080401 SL2 SUB

PLAN OF SUBDIVISION OF LOT 200 & 201 IN D.P. 1212253 AND LOT 1 IN D.P. 807298

SUBDIVISION OF BLOCK 1, BLOCK 1 NORTH, BLOCK 4 SOUTH AND BREWERY YARD IN 2 STAGES

LGA: SYDNEY
 Locality: CHIPPENDALE
 Subdivision No:
 Lengths are in metres. Reduction Ratio 1:500

REGISTERED CONTRACT PLAN
 Plan compiled from architectural CAD data.
 Plan is subject to final survey after completion of construction.

DRAFT
 PRINTED 14 MAR 2017
 ISSUE 16
 STAGE 4



STREET

ABERCROMBIE

BROADWAY

CHIPPENDALE WAY

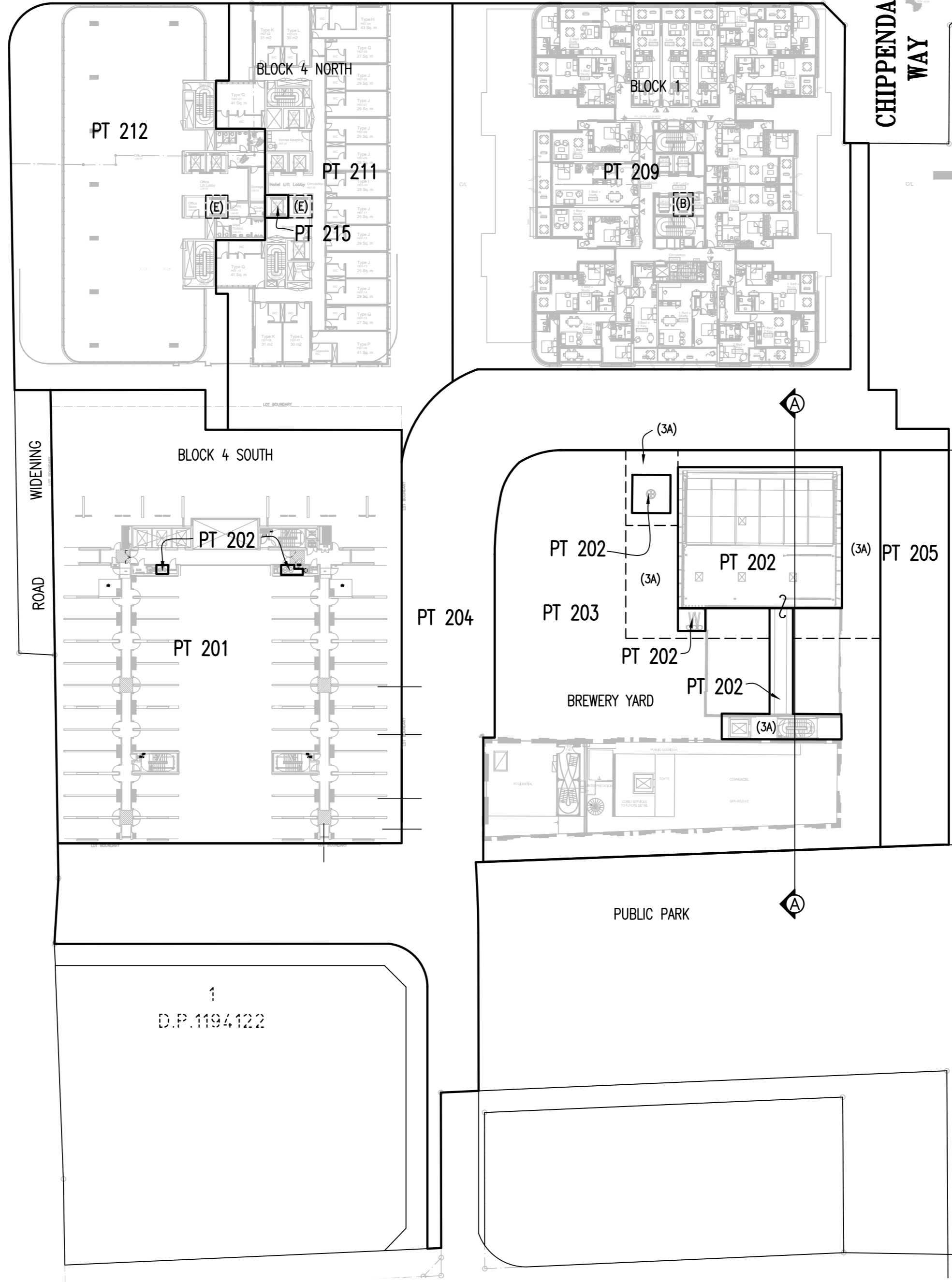

BLOCK 4 N HOTEL LEVELS 7-12
BLOCK 4N OFFICE LEVELS 7-10
BLOCK 4S & BREWERY YARD LEVELS 7-10

D.P.1181334

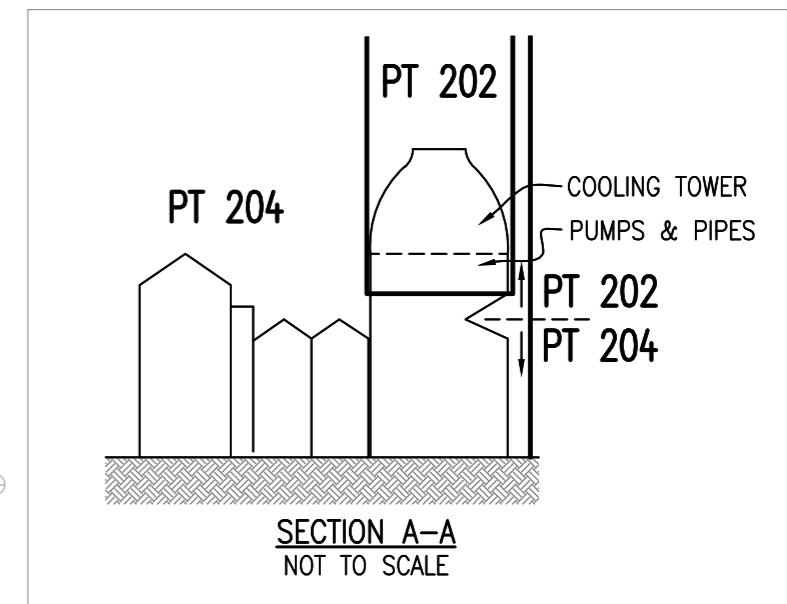

- WHOLE OF LOT EASEMENTS AFFECTING LOTS 201, 202, 203, 206, 209, 210, 211, 212, 213, 214 & 215
- EASEMENT FOR SUPPORT AND SHELTER
 - EASEMENT TO SERVICES
 - EASEMENT FOR FIRE STAIRS & PASSAGES
 - EASEMENT TO ACCESS FACILITIES

SCHEDULE OF STRATUM LOTS WITHIN STAGES 1 & 2

STAGE 1 LOTS

- LOT 201 - BLOCK 4S STUDENT ACCOMMODATION STRATUM LOT
- LOT 202 - CENTRAL THERMAL PLANT (CTP) STAGE 2 STRATUM LOT.
- LOT 203 - BREWERY YARD STRATUM LOT
- LOT 204 - PUBLIC ROAD STRATUM LOT
- LOT 205 - OPEN SPACE STRATUM LOT
- LOT 206 - BLOCK 4S RETAIL STRATUM LOT
- LOT 207 - 'PUB' STRATUM LOT
- LOT 208 - 'TERRACE' STRATUM LOT
- LOT 209 - BLOCK 1 RESIDENTIAL STRATUM LOT
- LOT 210 - BLOCK 1 RETAIL STRATUM LOT
- LOT 211 - BLOCK 4N HOTEL STRATUM LOT
- LOT 212 - BLOCK 4N COMMERCIAL STRATUM LOT
- LOT 213 - BLOCK 4N CHILDCARE STRATUM LOT
- LOT 214 - BREWERY YARD PARKING STRATUM LOT
- LOT 215 - BLOCK 4N RESIDENTIAL STRATUM LOT

PROPOSED EASEMENTS WITH RESPECT TO LOT 203

- (3A) - EASEMENT TO ACCESS AND MAINTAIN CTP TOWER INFRASTRUCTURE
- (B) - EASEMENT TO ACCESS AND USE LIFTS VARIABLE WIDTH (LIMITED IN STRATUM)
- (E) - EASEMENT TO ACCESS AND USE LIFTS VARIABLE WIDTH (LIMITED IN STRATUM)

Surveyor: TASY MORAITIS
Date of Survey:
Surveyor's Ref: 080401 SL2 SUB

PLAN OF SUBDIVISION OF LOT 200 & 201 IN D.P. 1212253 AND LOT 1 IN D.P. 807298
SUBDIVISION OF BLOCK 1, BLOCK 1 NORTH, BLOCK 4 SOUTH AND BREWERY YARD IN 2 STAGES

LGA: SYDNEY
Locality: CHIPPENDALE
Subdivision No:
Lengths are in metres. Reduction Ratio 1:500

REGISTERED CONTRACT PLAN
Plan compiled from architectural CAD data.
Plan is subject to final survey after completion of construction.

DRAFT
PRINTED 14 MAR 2017
ISSUE 16
STAGE 4

BLOCK 4N HOTEL LEVEL 13
 BLOCK 4N RESIDENTIAL LEVEL 11
 BLOCK 4S LEVELS 11 - 14



STREET

ABERCROMBIE

BROADWAY

CHIPPENDALE WAY



- (B) - EASEMENT TO ACCESS AND USE LIFTS VARIABLE WIDTH (LIMITED IN STRATUM)
- (E) - EASEMENT TO ACCESS AND USE LIFTS VARIABLE WIDTH (LIMITED IN STRATUM)

D.P.1181334

WHOLE OF LOT EASEMENTS AFFECTING LOTS 201, 202, 203, 206, 209, 210, 211, 212, 213, 214 & 215

- EASEMENT FOR SUPPORT AND SHELTER
- EASEMENT TO SERVICES
- EASEMENT FOR FIRE STAIRS & PASSAGES
- EASEMENT TO ACCESS FACILITIES

SCHEDULE OF STRATUM LOTS WITHIN STAGES 1 & 2

STAGE 1 LOTS

- LOT 201 - BLOCK 4S STUDENT ACCOMMODATION STRATUM LOT
- LOT 202 - CENTRAL THERMAL PLANT (CTP) STAGE 2 STRATUM LOT.
- LOT 203 - BREWERY YARD STRATUM LOT
- LOT 204 - PUBLIC ROAD STRATUM LOT
- LOT 205 - OPEN SPACE STRATUM LOT
- LOT 206 - BLOCK 4S RETAIL STRATUM LOT
- LOT 207 - 'PUB' STRATUM LOT
- LOT 208 - 'TERRACE' STRATUM LOT
- LOT 209 - BLOCK 1 RESIDENTIAL STRATUM LOT
- LOT 210 - BLOCK 1 RETAIL STRATUM LOT
- LOT 211 - BLOCK 4N HOTEL STRATUM LOT
- LOT 212 - BLOCK 4N COMMERCIAL STRATUM LOT
- LOT 213 - BLOCK 4N CHILDCARE STRATUM LOT
- LOT 214 - BREWERY YARD PARKING STRATUM LOT
- LOT 215 - BLOCK 4N RESIDENTIAL STRATUM LOT

Surveyor: TASY MORAITIS
 Date of Survey:
 Surveyor's Ref: 080401 SL2 SUB

PLAN OF SUBDIVISION OF LOT 200 & 201 IN
 D.P. 1212253 AND LOT 1 IN D.P. 807298

SUBDIVISION OF BLOCK 1, BLOCK 1 NORTH,
 BLOCK 4 SOUTH AND
 BREWERY YARD IN 2 STAGES

LGA: SYDNEY
 Locality: CHIPPENDALE
 Subdivision No:
 Lengths are in metres. Reduction Ratio 1:500

REGISTERED
 CONTRACT PLAN
 Plan compiled from
 architectural CAD data.
 Plan is subject to final
 survey after completion
 of construction.

DRAFT
 PRINTED 14 MAR 2017
 ISSUE 16
 STAGE 4

BLOCK 4N HOTEL LEVELS 14-18
BLOCK 4N RESEDENTIAL EVELS 12-16
BLOCK 1 LEVELS 14 - 18
BLOCK 4S LEVELS 15 & ABOVE



STREET

ABERCROMBIE

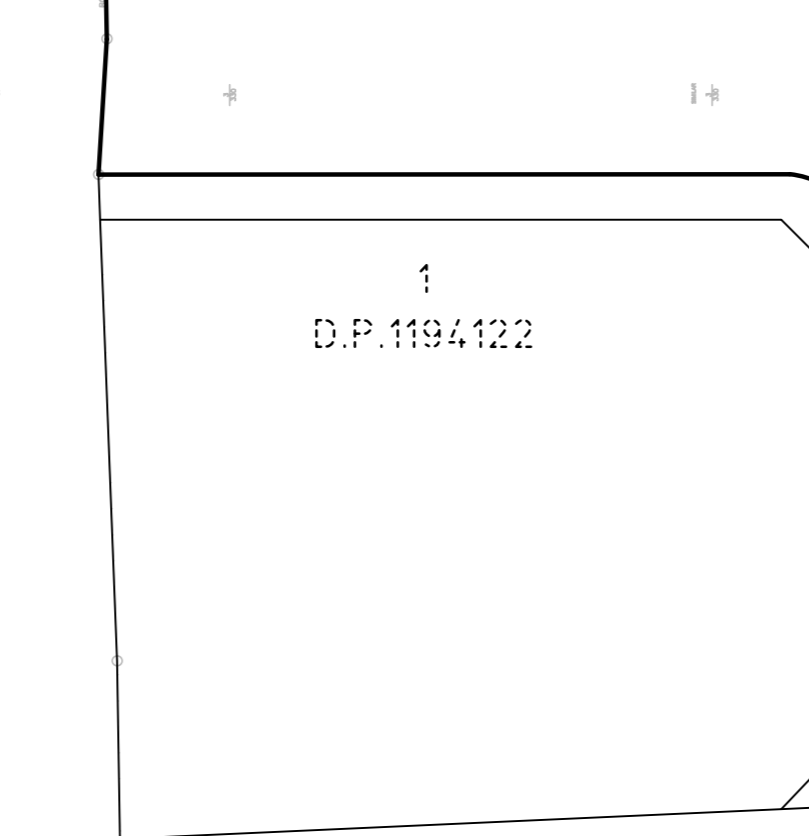
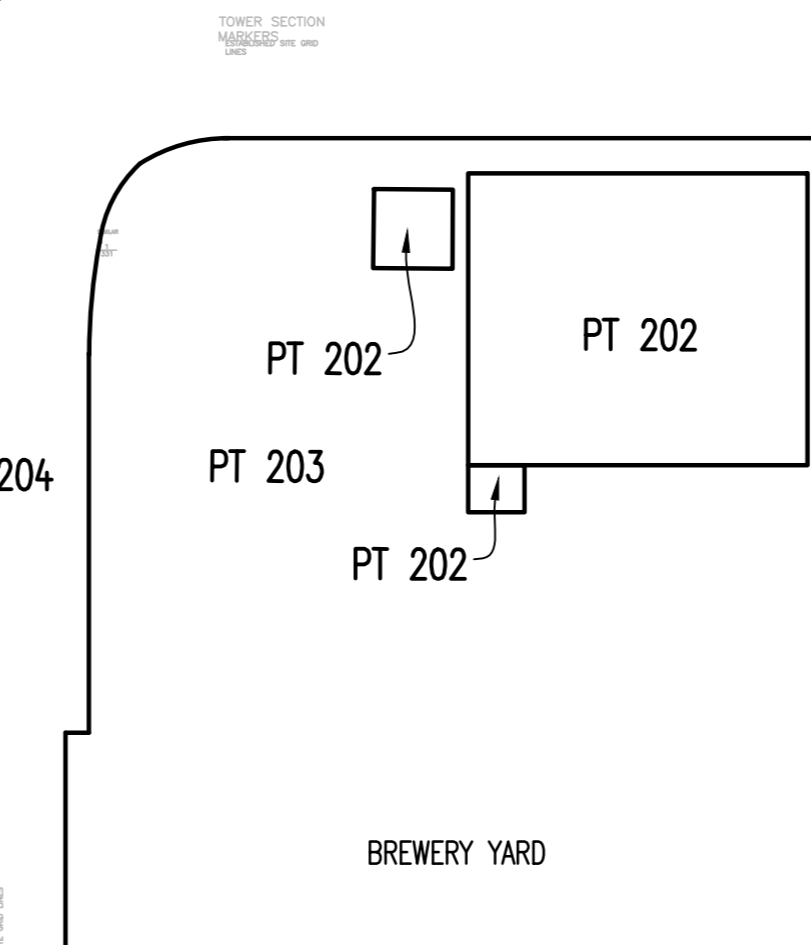
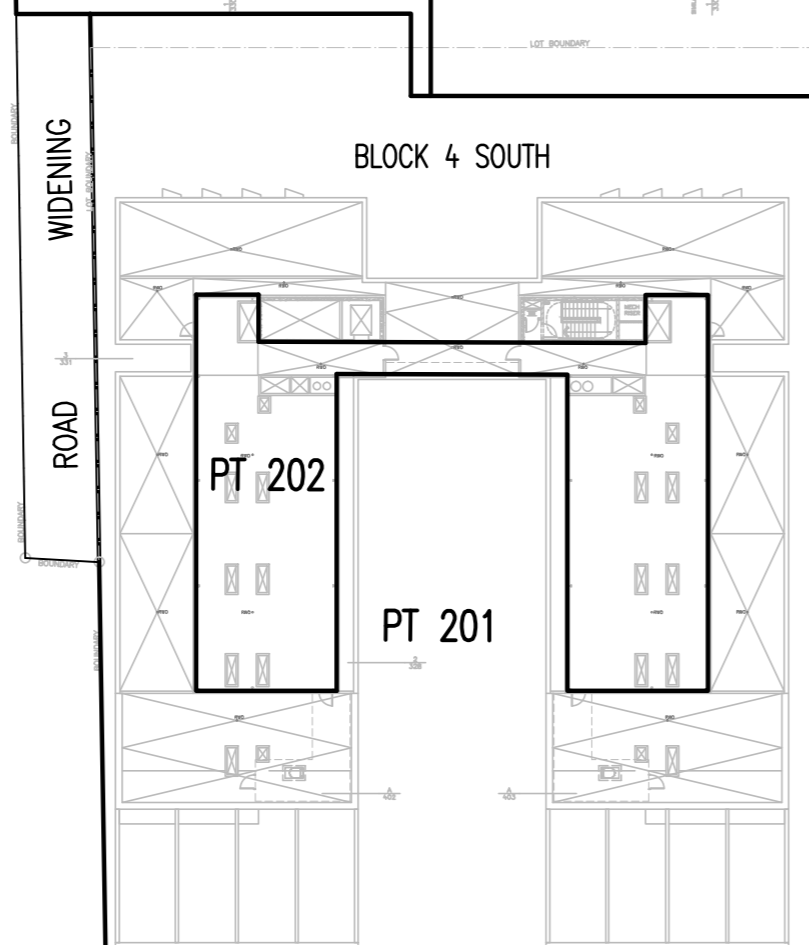
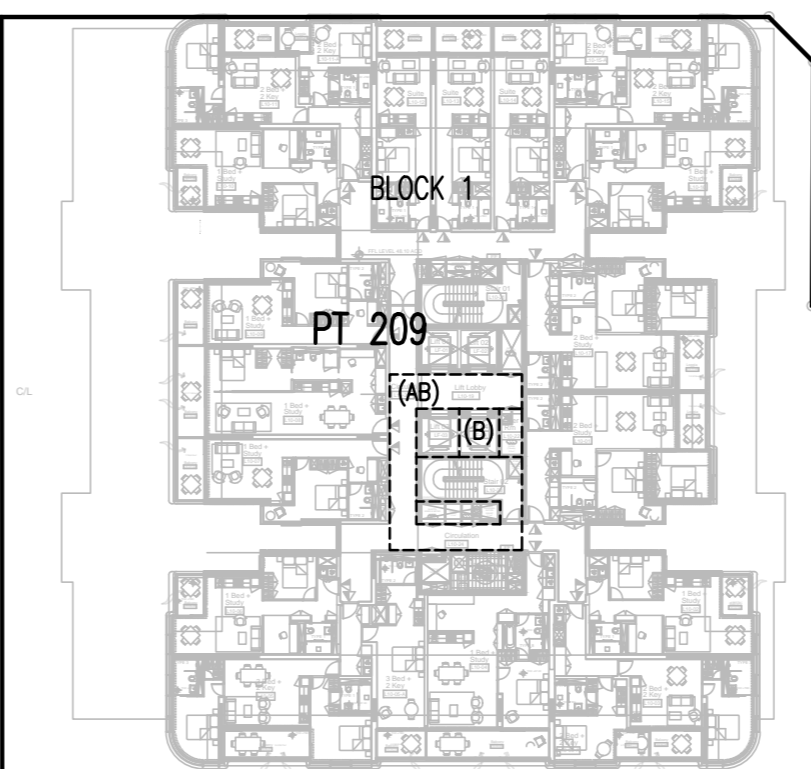
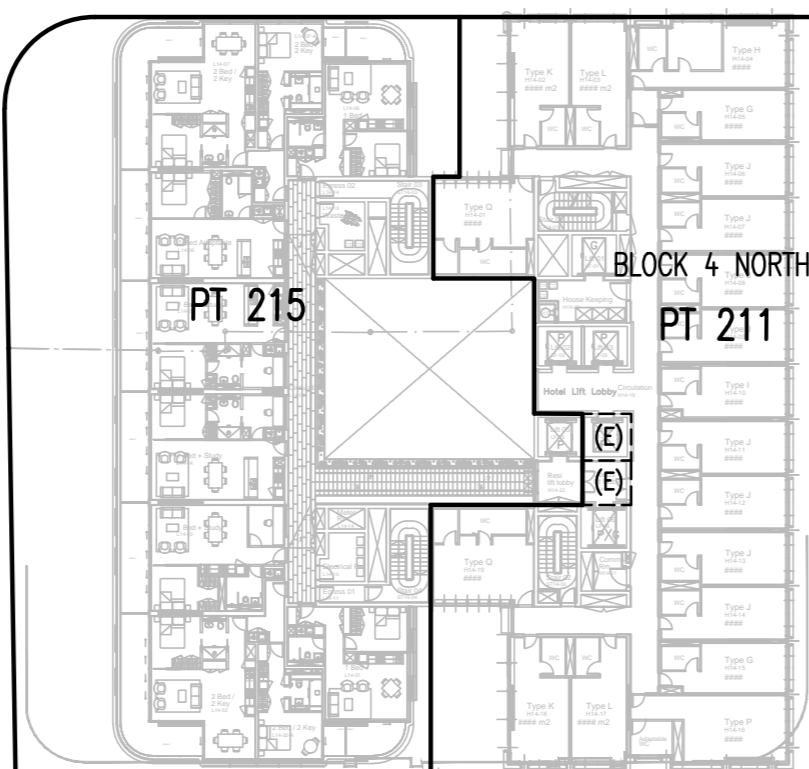

CHIPPENDALE WAY

- (AB) - EASEMENT FOR ROOF ACCESS VARIABLE WIDTH (LIMITED IN STRATUM)
- (B) - EASEMENT TO ACCESS AND USE LIFTS VARIABLE WIDTH (LIMITED IN STRATUM)
- (E) - EASEMENT TO ACCESS AND USE LIFTS VARIABLE WIDTH (LIMITED IN STRATUM)

D.P. 1181334

- WHOLE OF LOT EASEMENTS AFFECTING LOTS 201, 202, 203, 206, 209, 210, 211, 212, 213, 214 & 215
- EASEMENT FOR SUPPORT AND SHELTER
 - EASEMENT TO SERVICES
 - EASEMENT FOR FIRE STAIRS & PASSAGES
 - EASEMENT TO ACCESS FACILITIES

SCHEDULE OF STRATUM LOTS WITHIN STAGES 1 & 2

STAGE 1 LOTS

- LOT 201 - BLOCK 4S STUDENT ACCOMMODATION STRATUM LOT
- LOT 202 - CENTRAL THERMAL PLANT (CTP) STAGE 2 STRATUM LOT.
- LOT 203 - BREWERY YARD STRATUM LOT
- LOT 204 - PUBLIC ROAD STRATUM LOT
- LOT 205 - OPEN SPACE STRATUM LOT
- LOT 206 - BLOCK 4S RETAIL STRATUM LOT
- LOT 207 - 'PUB' STRATUM LOT
- LOT 208 - 'TERRACE' STRATUM LOT
- LOT 209 - BLOCK 1 RESIDENTIAL STRATUM LOT
- LOT 210 - BLOCK 1 RETAIL STRATUM LOT
- LOT 211 - BLOCK 4N HOTEL STRATUM LOT
- LOT 212 - BLOCK 4N COMMERCIAL STRATUM LOT
- LOT 213 - BLOCK 4N CHILDCARE STRATUM LOT
- LOT 214 - BREWERY YARD PARKING STRATUM LOT
- LOT 215 - BLOCK 4N RESIDENTIAL STRATUM LOT

Surveyor: TASY MORAITIS
 Date of Survey:
 Surveyor's Ref: 080401 SL2 SUB

PLAN OF SUBDIVISION OF LOT 200 & 201 IN
 D.P. 1212253 AND LOT 1 IN D.P. 807298
 SUBDIVISION OF BLOCK 1, BLOCK 1 NORTH,
 BLOCK 4 SOUTH AND
 BREWERY YARD IN 2 STAGES

LGA: SYDNEY
 Locality: CHIPPENDALE
 Subdivision No:
 Lengths are in metres. Reduction Ratio 1:500

REGISTERED
 CONTRACT PLAN
 Plan compiled from
 architectural CAD data.
 Plan is subject to final
 survey after completion
 of construction.

DRAFT
 PRINTED 14 MAR 2017
 ISSUE 16
 STAGE 4

LEVEL 19



STREET

ABERCROMBIE

ROAD
WIDENING

BROADWAY

CHIPPENDALE
WAY

D.P.1181334

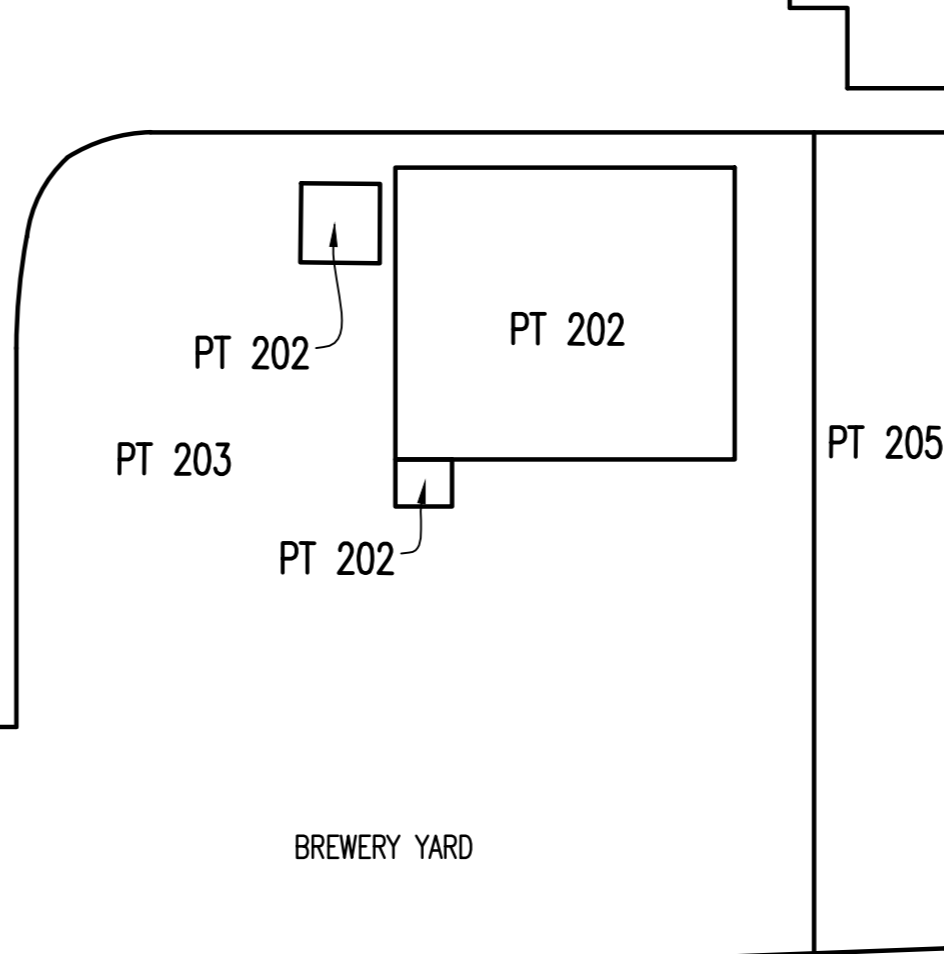
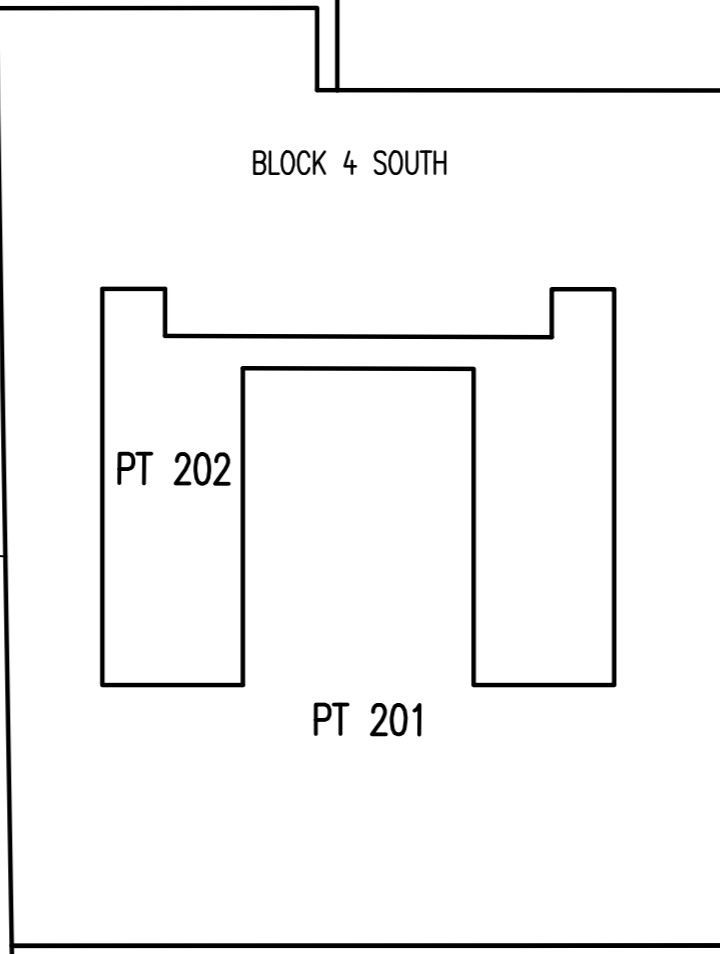
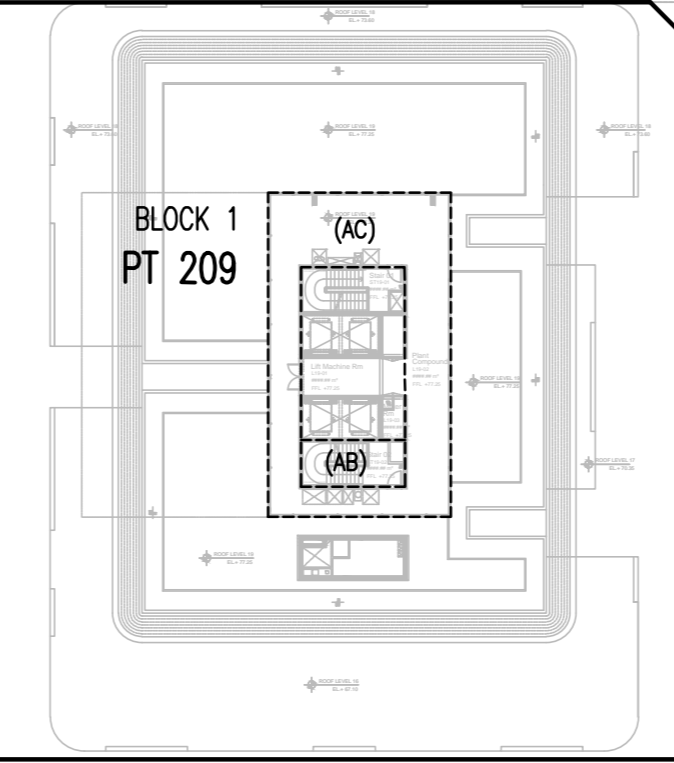
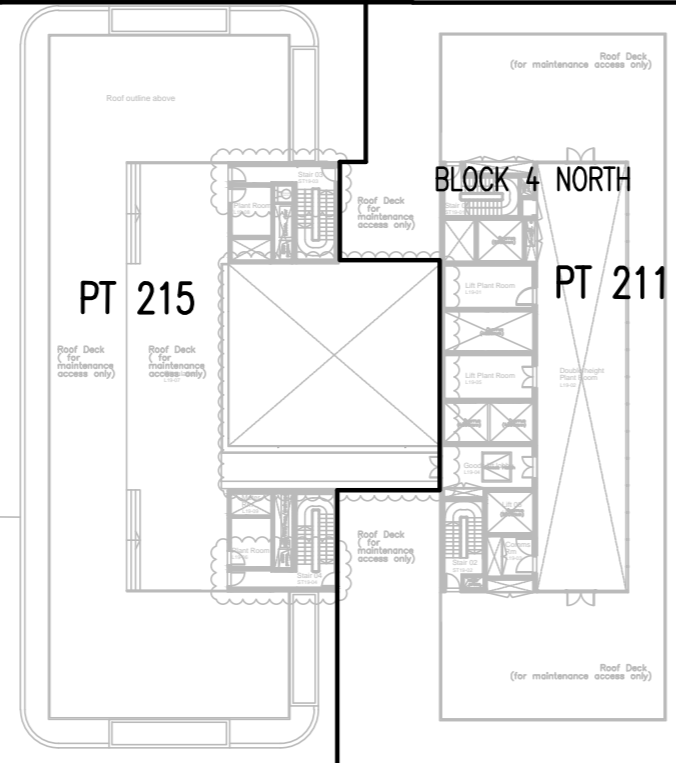

- WHOLE OF LOT EASEMENTS AFFECTING LOTS 201, 202, 203, 206, 209, 210, 211, 212, 213, 214 & 215
- EASEMENT FOR SUPPORT AND SHELTER
 - EASEMENT TO SERVICES
 - EASEMENT FOR FIRE STAIRS & PASSAGES
 - EASEMENT TO ACCESS FACILITIES

SCHEDULE OF STRATUM LOTS WITHIN STAGES 1 & 2

STAGE 1 LOTS

- LOT 201 - BLOCK 4S STUDENT ACCOMMODATION STRATUM LOT
- LOT 202 - CENTRAL THERMAL PLANT (CTP) STAGE 2 STRATUM LOT.
- LOT 203 - BREWERY YARD STRATUM LOT
- LOT 204 - PUBLIC ROAD STRATUM LOT
- LOT 205 - OPEN SPACE STRATUM LOT
- LOT 206 - BLOCK 4S RETAIL STRATUM LOT
- LOT 207 - 'PUB' STRATUM LOT
- LOT 208 - 'TERRACE' STRATUM LOT
- LOT 209 - BLOCK 1 RESIDENTIAL STRATUM LOT
- LOT 210 - BLOCK 1 RETAIL STRATUM LOT
- LOT 211 - BLOCK 4N HOTEL STRATUM LOT
- LOT 212 - BLOCK 4N COMMERCIAL STRATUM LOT
- LOT 213 - BLOCK 4N CHILDCARE STRATUM LOT
- LOT 214 - BREWERY YARD PARKING STRATUM LOT
- LOT 215 - BLOCK 4N RESIDENTIAL STRATUM LOT

- (AB) - EASEMENT FOR ROOF ACCESS VARIABLE WIDTH (LIMITED IN STRATUM)
- (AC) - EASEMENT FOR KITCHEN EXHAUST PURPOSES VARIABLE WIDTH (LIMITED IN STRATUM)

1
D.P.1194122

Surveyor: TASY MORAITIS
 Date of Survey:
 Surveyor's Ref: 080401 SL2 SUB

PLAN OF SUBDIVISION OF LOT 200 & 201 IN
 D.P. 1212253 AND LOT 1 IN D.P. 807298

SUBDIVISION OF BLOCK 1, BLOCK 1 NORTH,
 BLOCK 4 SOUTH AND
 BREWERY YARD IN 2 STAGES

LGA: SYDNEY
 Locality: CHIPPENDALE
 Subdivision No:
 Lengths are in metres. Reduction Ratio 1:500

REGISTERED
 CONTRACT PLAN
 Plan compiled from
 architectural CAD data.
 Plan is subject to final
 survey after completion
 of construction.

DRAFT
 PRINTED 14 MAR 2017
 ISSUE 16
 STAGE 4

**ROOF LEVEL
LEVEL 20 & ABOVE**

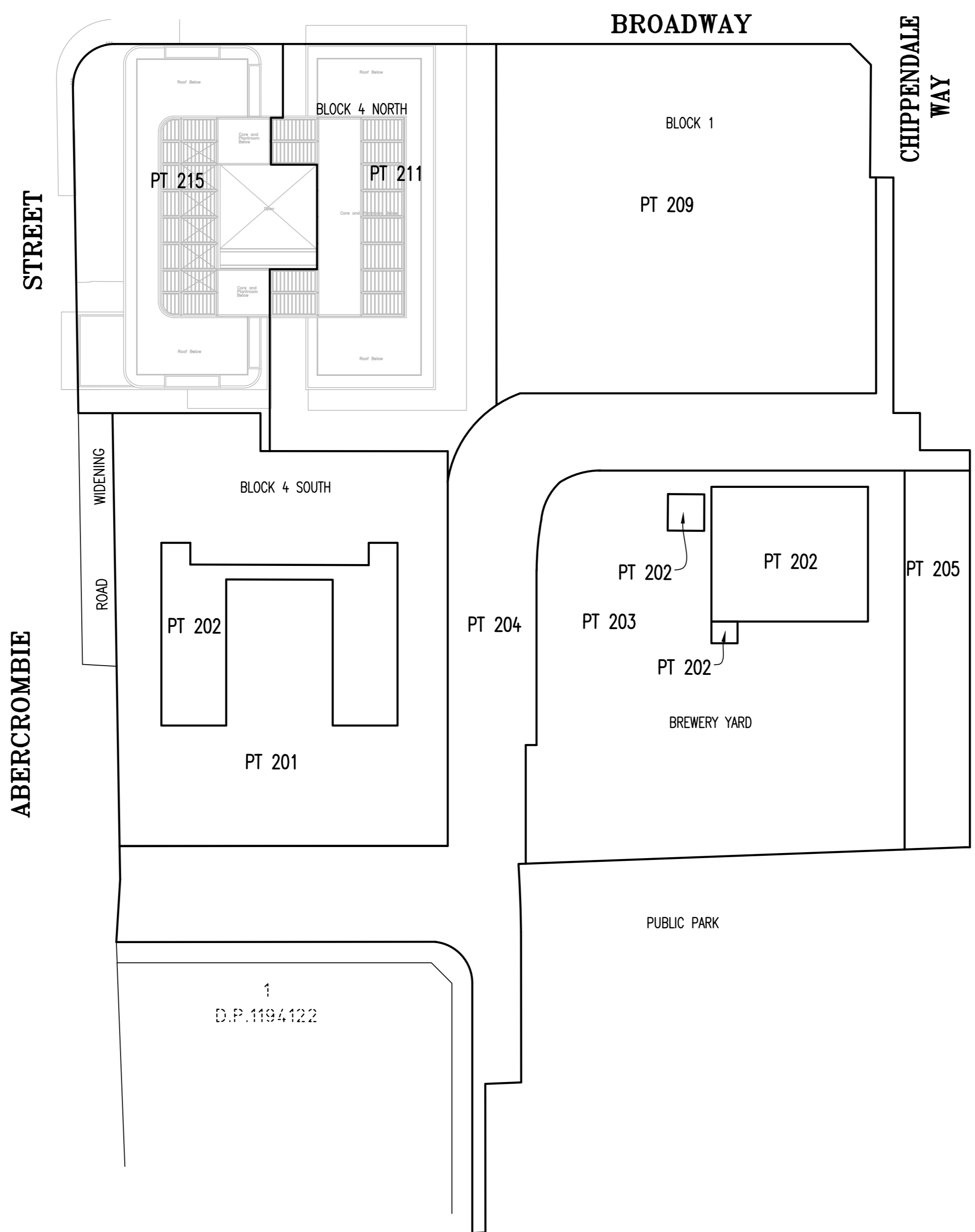

- WHOLE OF LOT EASEMENTS AFFECTING LOTS 201, 202, 203, 206, 209, 210, 211, 212, 213, 214 & 215
- EASEMENT FOR SUPPORT AND SHELTER
 - EASEMENT TO SERVICES
 - EASEMENT FOR FIRE STAIRS & PASSAGES
 - EASEMENT TO ACCESS FACILITIES

SCHEDULE OF STRATUM LOTS WITHIN STAGES 1 & 2

STAGE 1 LOTS

- LOT 201 - BLOCK 4S STUDENT ACCOMMODATION STRATUM LOT
- LOT 202 - CENTRAL THERMAL PLANT (CTP) STAGE 2 STRATUM LOT.
- LOT 203 - BREWERY YARD STRATUM LOT
- LOT 204 - PUBLIC ROAD STRATUM LOT
- LOT 205 - OPEN SPACE STRATUM LOT
- LOT 206 - BLOCK 4S RETAIL STRATUM LOT
- LOT 207 - 'PUB' STRATUM LOT
- LOT 208 - 'TERRACE' STRATUM LOT
- LOT 209 - BLOCK 1 RESIDENTIAL STRATUM LOT
- LOT 210 - BLOCK 1 RETAIL STRATUM LOT
- LOT 211 - BLOCK 4N HOTEL STRATUM LOT
- LOT 212 - BLOCK 4N COMMERCIAL STRATUM LOT
- LOT 213 - BLOCK 4N CHILDCARE STRATUM LOT
- LOT 214 - BREWERY YARD PARKING STRATUM LOT
- LOT 215 - BLOCK 4N RESIDENTIAL STRATUM LOT

Surveyor: TASY MORAITIS
 Date of Survey:
 Surveyor's Ref: 080401 SL2 SUB

PLAN OF SUBDIVISION OF LOT 200 & 201 IN
 D.P. 1212253 AND LOT 1 IN D.P. 807298

SUBDIVISION OF BLOCK 1, BLOCK 1 NORTH,
 BLOCK 4 SOUTH AND
 BREWERY YARD IN 2 STAGES

LGA: SYDNEY
 Locality: CHIPPENDALE
 Subdivision No:
 Lengths are in metres. Reduction Ratio 1:500

REGISTERED
 CONTRACT PLAN
 Plan compiled from
 architectural CAD data.
 Plan is subject to final
 survey after completion
 of construction.

DRAFT
 PRINTED 14 MAR 2017
 ISSUE 16
 STAGE 4