







WESTERN SYDNEY UNIVERSITY TEMPORARY CARPARK FIFTH STREET, PARRAMATTA NSW 2116 ELECTRICAL SERVICES AND LIGHTING FOR TENDER

DRAWING LIST

E1000	COVER SHEET AND LEGEND
E1100	LIGHTING DETAILS
E2000	ELECTRICAL SITE PLAN
E3000	LIGHTING SITE PLAN
E3100	LIGHTING LAYOUT - SHEET 1
E3101	LIGHTING LAYOUT - SHEET 2

LEGEND

	12-METRE HIGH POLE WITH SINGLE LUMINAIRE HEAD
	12-METRE HIGH POLE WITH DOUBLE LUMINAIRE HEAD
	MDB IN ED.G.03 (EXISTING)
	NEW 63A 12-POLE DISTRIBUTION BOARD FOR TEMP. CAR PARK AREA IN AN IP54 EXTERNAL ENCLOSURE
	NEW 4C 25MM2 XLPE CU CABLES IN 2x150mm HDPE CONDUITS FROM MDB TO FEEDER PILLAR (SPARE CONDUIT INCLUSIVE)
	EXISTING ELECTRICAL PITS

FOR TENDER
THIS IS NOT A WORKSHOP DRAWING
NOT FOR CONSTRUCTION. IT IS THE CONTRACTORS RESPONSIBILITY TO PROVIDE CONSTRUCTIONAL DIMENSIONED WORKSHOP DRAWINGS IN ACCORDANCE WITH THE RELEVANT SECTIONS IN THE SPECIFICATION

DESIGNED UNDER QUALITY SYSTEM CERTIFIED AS COMPLYING WITH ISO 9001 BY AN ACCREDITED CERTIFICATION BODY
© Copyright. This Document and Design remains the copyright of Steensen Varming (Australia) Pty Ltd and cannot be reproduced in any way without prior consent. The contractor shall verify all dimensions and levels on site as this is not a workshop drawing. The contractor shall refer any discrepancies to the engineer before proceeding with the work. This drawing shall be read in conjunction with other contract documents, drawings and project specifications. This file has been checked by an antivirus program with the latest updates. However new viruses are discovered everyday we recommend that this file is rescanned upon receipt

AMENDMENTS		
REV	DESCRIPTION	DATE
A	FOR TENDER	04/10/24
B	FOR TENDER	27/06/25

Copenhagen London Sydney Hong Kong New York
8, 9 Castlereagh St. Sydney, NSW, 2000, Australia
ABN 50 001 189 037
t : +61 / 02 9967 2200
e : info@steensenvarming.com

STEENSEN VARMING

PROJECT
**WSU TEMPORARY CARPARK
FIFTH STREET, PARRAMATTA NSW 2116**

DRAWING TITLE
**ELECTRICAL SERVICES AND LIGHTING
COVER SHEET AND LEGEND**

CREATED	DRAWN	DESIGNED	CHECKED	APPROVED	SCALE
JUN'25	MS	MS/MM	SS	SS	NTS
NORTHPOINT		PROJECT No.	DRAWING No.	REVISION	
		247150	SV_E1000	B	

FOR TENDER

A1

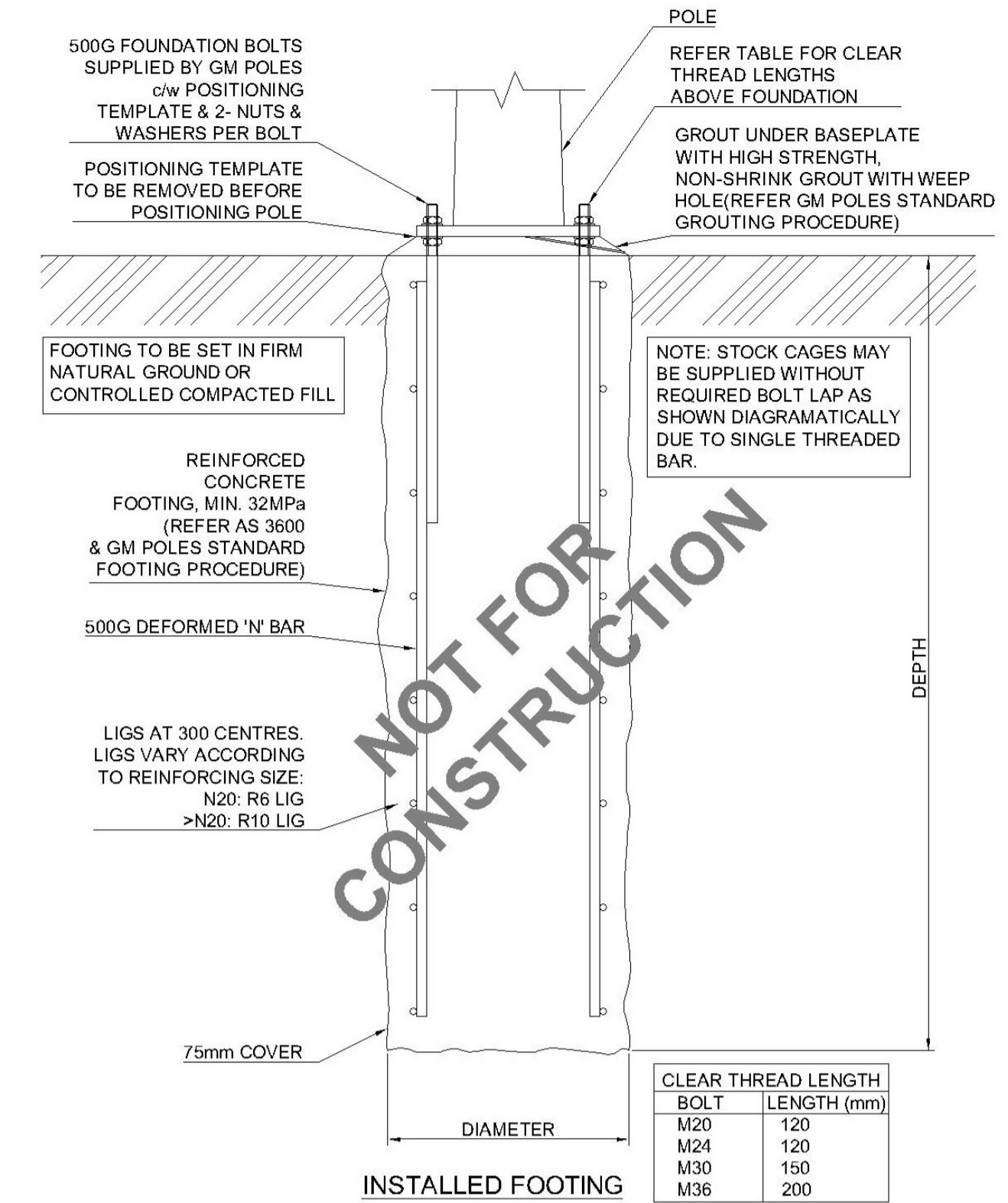
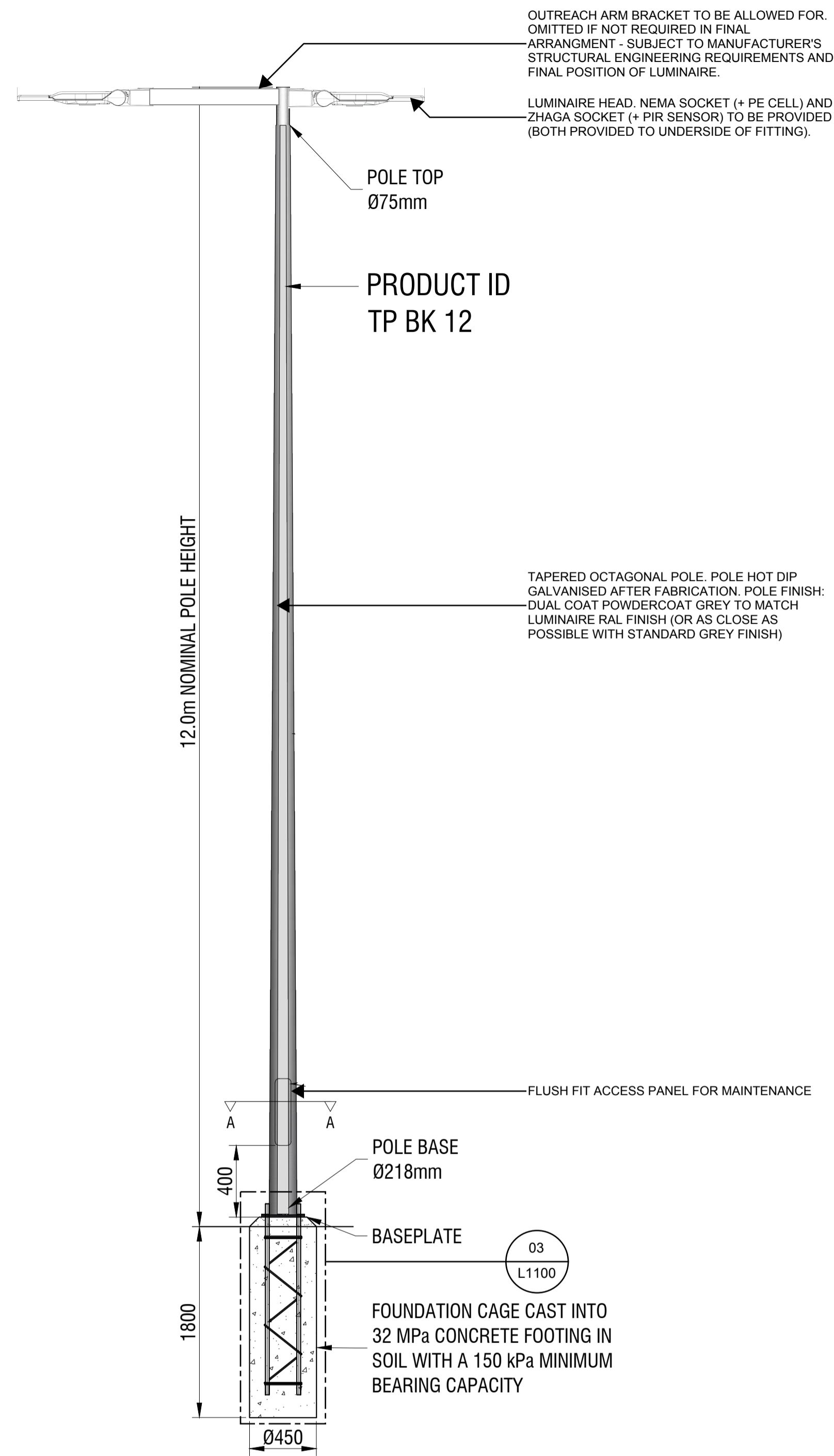
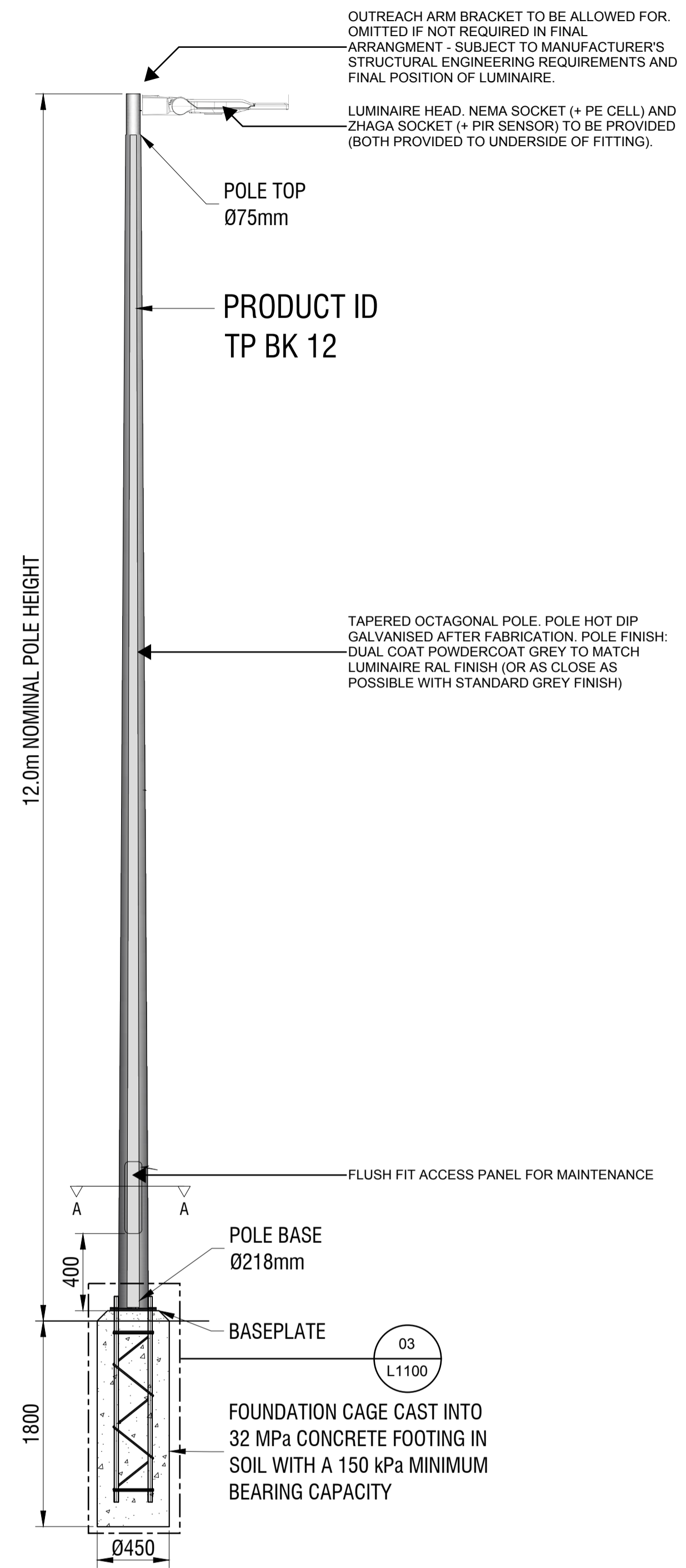

NOT FOR CONSTRUCTION

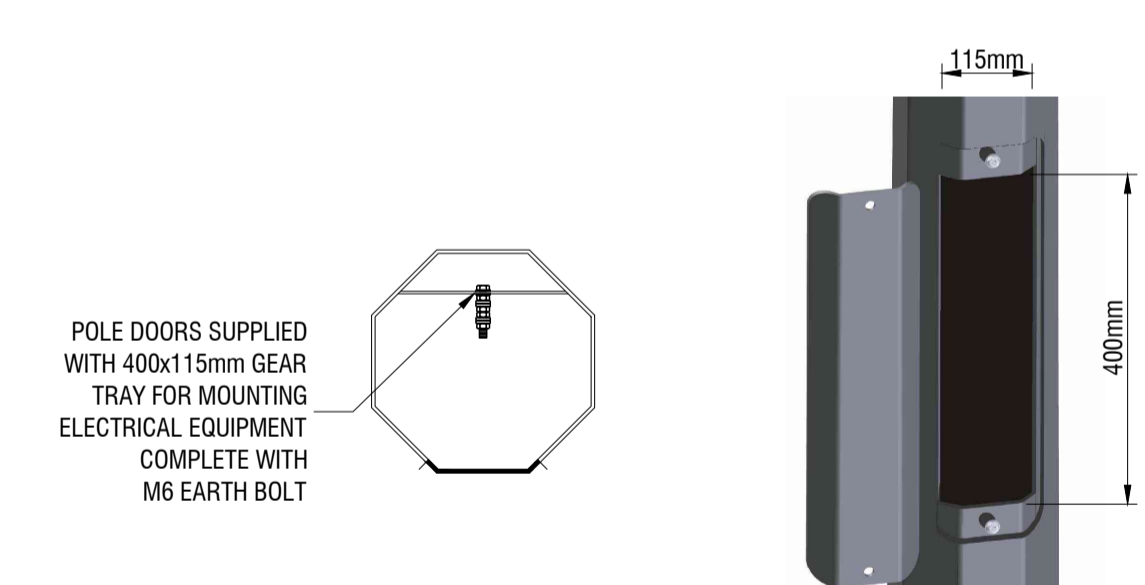
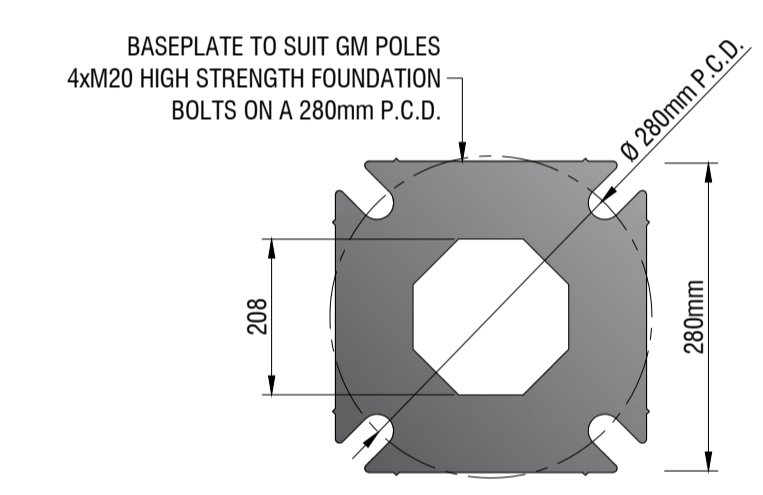

1 12-METRE HIGH POLE WITH SINGLE LUMINAIRE HEAD NTS

- NOTES:
- POLE POSITIONS TO BE COORDINATIONED BY CONTRACTOR WITH FINAL SET-BACK IN ACCORDANCE WITH AS/NZS 1158 AND TTW'S REQUIREMENTS. TO BE MINIMUM 500MM FROM ANY STORMWATER SERVICES. REFER TO TTW FOR KERB/ROAD DETAIL. POLE LOCATIONS ARE INDICATIVE ONLY AND DEMONSTRATE THE POSITIONS THAT PROVIDE COMPLIANCE WITH THE LTP'S OF AS/NZS 1158. CONTRACTOR TO COORDINATE EXACT AND FINAL SET OUT AND SET BACK OF POLES. CONTRACTOR TO ALLOW FOR MODIFICATION OF POLE AND PROVISION OF AN OUTREACH ARM IN THIS COORDINATION.
 - CONTRACTOR TO PROVIDE SHOP DRAWINGS OF FINAL ARRANGEMENT FOR APPROVAL.
 - REFER TO ELECTRICAL CONSULTANT FOR ALL ELECTRICAL CONNECTION DETAILS, CIRCUITING AND RETICULATION.
 - FOOTING DETAILS ARE INDICATIVE ONLY. FINAL DETAIL TO MANUFACTURER'S REQUIREMENTS/ ENGINEER'S SPECIFICATION TO SUIT SITE CONDITIONS INCLUDING SOIL, WIND AND NEW CIVIL WORKS.

2 12-METRE HIGH POLE WITH DOUBLE LUMINAIRE HEADS NTS

- NOTES:
- POLE POSITIONS TO BE COORDINATIONED BY CONTRACTOR WITH FINAL SET-BACK IN ACCORDANCE WITH AS/NZS 1158 AND TTW'S REQUIREMENTS. TO BE MINIMUM 500MM FROM ANY STORMWATER SERVICES. REFER TO TTW FOR KERB/ROAD DETAIL. POLE LOCATIONS ARE INDICATIVE ONLY AND DEMONSTRATE THE POSITIONS THAT PROVIDE COMPLIANCE WITH THE LTP'S OF AS/NZS 1158. CONTRACTOR TO COORDINATE EXACT AND FINAL SET OUT AND SET BACK OF POLES. CONTRACTOR TO ALLOW FOR MODIFICATION OF POLE AND PROVISION OF AN OUTREACH ARM IN THIS COORDINATION.
 - CONTRACTOR TO PROVIDE SHOP DRAWINGS OF FINAL ARRANGEMENT FOR APPROVAL.
 - REFER TO ELECTRICAL CONSULTANT FOR ALL ELECTRICAL CONNECTION DETAILS, CIRCUITING AND RETICULATION.
 - FOOTING DETAILS ARE INDICATIVE ONLY. FINAL DETAIL TO MANUFACTURER'S REQUIREMENTS/ ENGINEER'S SPECIFICATION TO SUIT SITE CONDITIONS INCLUDING SOIL, WIND AND NEW CIVIL WORKS.

3 INDICATIVE POLE FOOTING, BASEPLATE AND DOOR DETAILS NTS

- NOTES:
- FOOTING DETAIL SHALL CONFORM WITH THE MANUFACTURER'S REQUIREMENTS FOR A 12 METRE HIGH POLE.
 - DETAILS HAVE BEEN PROVIDED BY THE MANUFACTURER AND ARE INDICATIVE ONLY.
 - FINAL DETAIL TO MANUFACTURER'S REQUIREMENTS AND TO BE DESIGNED AND CERTIFIED BY STRUCTURAL ENGINEER TO SUIT SITE CONDITIONS INCLUDING SOIL, WIND, AND NEW CIVIL WORKS.
 - CONTRACTOR TO PROVIDE SHOP DRAWINGS OF FINAL ARRANGEMENT FOR APPROVAL.

FOR TENDER
THIS IS NOT A WORKSHOP DRAWING
NOT FOR CONSTRUCTION. IT IS THE CONTRACTOR'S RESPONSIBILITY TO PROVIDE CONSTRUCTIONAL DIMENSIONED WORKSHOP DRAWINGS IN ACCORDANCE WITH THE RELEVANT SECTIONS IN THE SPECIFICATION.

DESIGNED UNDER QUALITY SYSTEM CERTIFIED AS COMPLYING WITH ISO 9001 BY AN ACCREDITED CERTIFICATION BODY
© Copyright. This Document and Design remains the copyright of Steensen Varming (Australia) Pty Ltd and cannot be reproduced in any way without prior consent. The contractor shall verify all dimensions and levels on site as this is not a workshop drawing. The contractor shall refer any discrepancies to the engineer before proceeding with the work. This drawing shall be read in conjunction with other contract documents, drawings and project specifications. This file has been checked by an antivirus program with the latest update. However new viruses are discovered everyday we recommend that this file is rescanned upon receipt

AMENDMENTS		
REV	DESCRIPTION	DATE
A	FOR TENDER	04/10/24
B	FOR TENDER	27/06/25

Copenhagen 8, 9 Castlereagh St.
London Sydney, NSW, 2000, Australia
Sydney ABN 50 001 189 037
Hong Kong t: +61 / 02 9967 2200
New York e: info@steensenvarming.com

STEENSEN VARMING

PROJECT
WSU TEMPORARY CARPARK
FIFTH STREET, PARRAMATTA NSW 2116

DRAWING TITLE
ELECTRICAL SERVICES AND LIGHTING
LIGHTING DETAILS

CREATED	DRAWN	DESIGNED	CHECKED	APPROVED	SCALE
JUN'25	MS	MS/MM	SS	SS	NTS
NORTHPOINT	PROJECT No.	DRAWING No.	REVISION		
	247150	SV_E1100	B		

FOR TENDER

A1



NOTES:

1. CONDUITS ROUTE SHOWN HERE INDICATIVELY. THE EXACT CONDUITS ROUTE SHALL BE PROPOSED BY THE CONTRACTOR AFTER CARRYING OUT SITE VISITS WITH MINIMUM ENVIRONMENTAL IMPACTS.
 2. 2x50MM NEW HDPE CONDUITS SHALL BE INSTALLED FROM NEW FEEDER PILLAR (DB EX) TO THE LIGHT POLES FOOTING FOR LIGHTING WIRING.
 3. ELECTRICAL PITS INDICATED HERE AS INFORMATION OBTAINED FROM WSU AS-BUILT DRAWINGS. IN THE ABSENCE OF THESE PITS, NEW 600MM SQUARE ELECTRICAL PITS SHALL BE PROVIDED ALONG THE RETICULATION OF THE SUBMANS.
 4. CONTRACTOR TO PROVIDE SHOP DRAWINGS OF FINAL ARRANGEMENT FOR APPROVAL.
 5. FINAL QUANTITY & LOCATION OF THE LIGHT POLES AS PER THE LIGHTING DESIGN DRAWINGS.
- ALL ELECTRICAL INSTALLATION AS PER AS/NZS 3000 REQUIREMENTS WITH NO MORE THAN 12 LIGHT FITTINGS PER CIRCUIT.

SPARE 250A BREAKER IN MDB (LOCATION : ED.G.03)



SPARE 250A BREAKER IN MDB (LOCATION : ED.G.03)

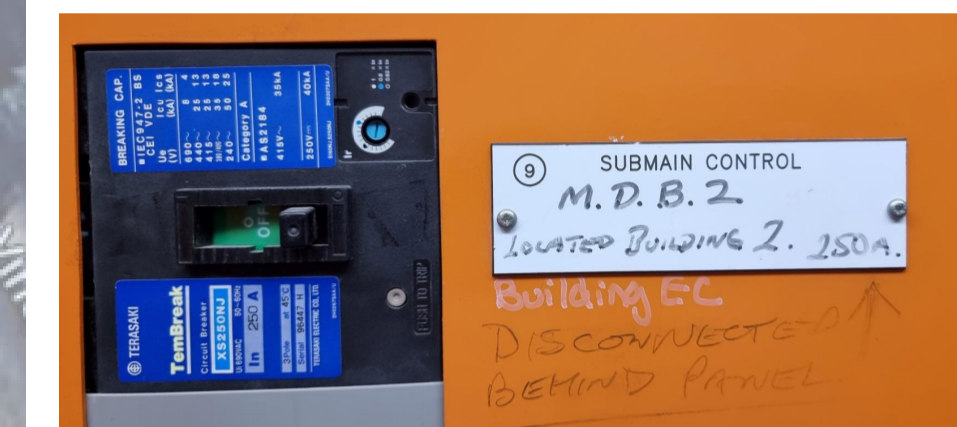

FOR TENDER

THIS IS NOT A WORKSHOP DRAWING

NOT FOR CONSTRUCTION. IT IS THE CONTRACTORS RESPONSIBILITY TO PROVIDE CONSTRUCTIONAL DIMENSIONED WORKSHOP DRAWINGS IN ACCORDANCE WITH THE RELEVANT SECTIONS IN THE SPECIFICATION.

DESIGNED UNDER QUALITY SYSTEM CERTIFIED AS COMPLYING WITH ISO 9001 BY AN ACCREDITED CERTIFICATION BODY

© Copyright. This Document and Design remains the copyright of Steensen Varming (Australia) Pty Ltd and cannot be reproduced in any way without prior consent. The contractor shall verify all dimensions and levels on site as this is not a workshop drawing. The contractor shall refer any discrepancies to the engineer before proceeding with the work. This drawing shall be read in conjunction with other contract documents, drawings and project specifications. This file has been checked by an antivirus program with the latest updates. However, new viruses are discovered everyday we recommend that this file is rescanned upon receipt

AMENDMENTS		
REV	DESCRIPTION	DATE
A	FOR TENDER	04/10/24
B	FOR TENDER	27/06/25

Copenhagen
London
Sydney
Hong Kong
New York

8, 9 Castlereagh St.
Sydney, NSW, 2000, Australia
ABN 50 001 189 037
t : +61 / 02 9967 2200
e : info@steensenvarming.com

PROJECT
WSU CARPARK REPLACEMENT
FIFTH STREET, PARRAMATTA NSW 2116

DRAWING TITLE
ELECTRICAL SERVICES AND LIGHTING
ELECTRICAL SITE PLAN

CREATED	DRAWN	DESIGNED	CHECKED	APPROVED	SCALE
JUN'25	MM	MM	IM	SS	NTS
NORTHPOINT	PROJECT No.	DRAWING No.	REVISION		
	247150	SV_E2000	B		

FOR TENDER

STEENSEN VARMING

A1

NOTES:

1. CONTRACTOR SHALL SIZE THE NEW DISTRIBUTION BOARD AS PER THE FINAL CIRCUITRY OF LIGHT FITTINGS.
2. THE NEW DISTRIBUTION BOARD DB EX SHALL BE INSTALLED WITHIN IP54 ENCLOSURE (WEATHERPROOF).
3. AS PART OF THE CONTRACTORS DESIGN FINALISATION, THE CONTRACTOR SHALL DESIGN THE SINGLE LINE DIAGRAM OF THE PROPOSED DB.

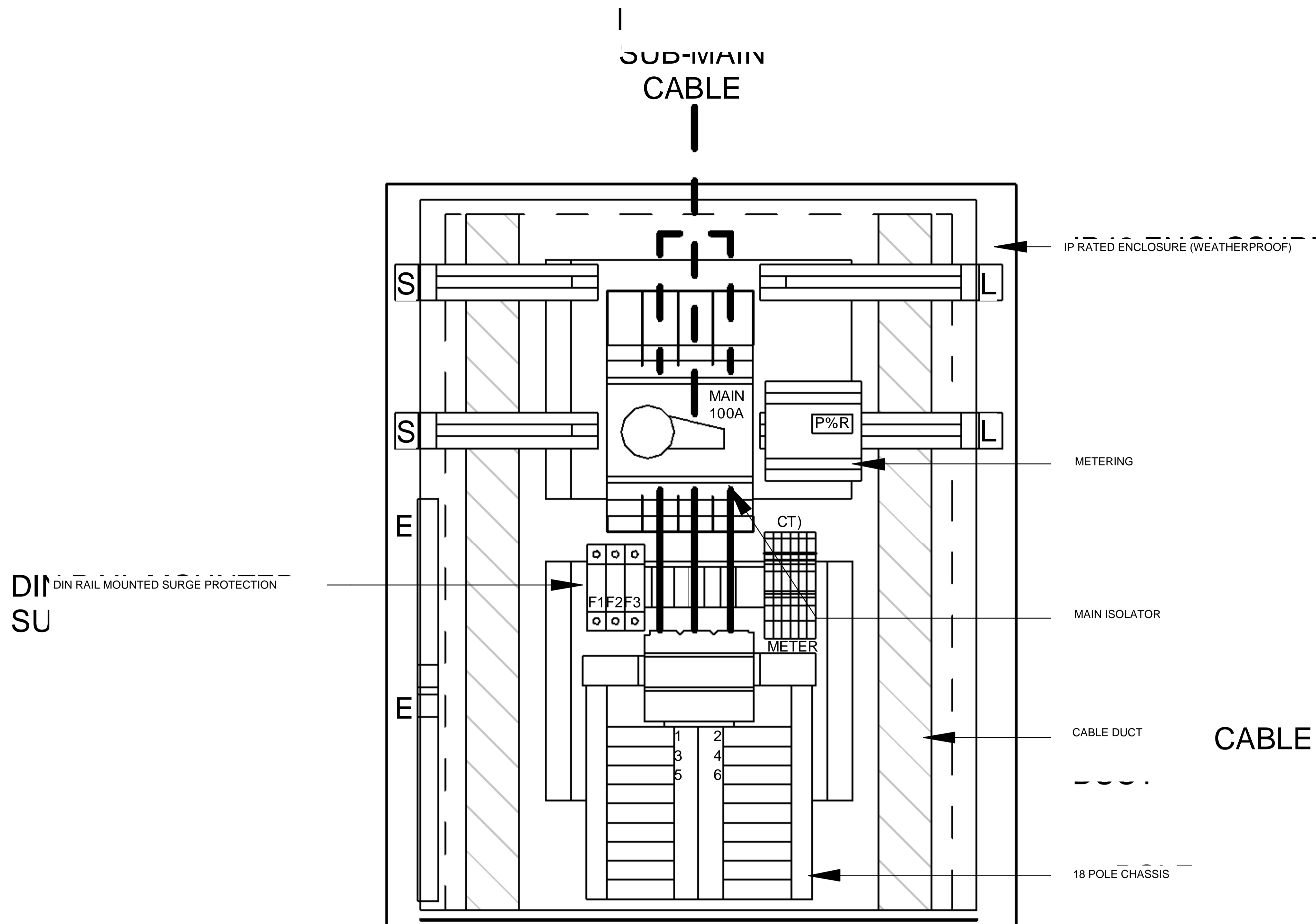

DB EX - 18 POLE DB DETAIL IN IP54 ENCLOSURE

FOR TENDER
THIS IS NOT A WORKSHOP DRAWING
NOT FOR CONSTRUCTION. IT IS THE CONTRACTORS RESPONSIBILITY TO PROVIDE CONSTRUCTIONAL DIMENSIONED WORKSHOP DRAWINGS IN ACCORDANCE WITH THE RELEVANT SECTIONS IN THE SPECIFICATION.

DESIGNED UNDER QUALITY SYSTEM CERTIFIED AS COMPLYING WITH ISO 9001 BY AN ACCREDITED CERTIFICATION BODY

© Copyright. This Document and Design remains the copyright of Steensen Varming (Australia) Pty Ltd and cannot be reproduced in any way without prior consent. The contractor shall verify all dimensions and levels on site as this is not a workshop drawing. The contractor shall refer any discrepancies to the engineer before proceeding with the work. This drawing shall be read in conjunction with other contract documents, drawings and project specifications. This file has been checked by an antivirus program with the latest updates. However new viruses are discovered everyday we recommend that this file is rescanned upon receipt.

AMENDMENTS		
REV	DESCRIPTION	DATE
A	FOR TENDER	06/11/24
B	FOR TENDER	27/06/25

Copenhagen
London
Sydney
Hong Kong
New York

8, 9 Castlereagh St.
Sydney, NSW, 2000, Australia
ABN 50 001 189 037
t : +61 / 02 9967 2200
e : info@steensenvarming.com

STEENSEN VARMING

PROJECT
**WSU TEMPORARY CARPARK
FIFTH STREET, PARRAMATTA NSW 2116**

DRAWING TITLE
**ELECTRICAL SERVICES AND LIGHTING
DISTRIBUTION BOARD DETAILS - DB EX**

CREATED DRAWN DESIGNED CHECKED APPROVED SCALE

JUN'25 MM MM IM SS NTS

NORTHPOINT PROJECT No. DRAWING No. REVISION

247150 SV_E2001 B

FOR TENDER

A1

NOTES:

1. ALL EXISTING LIGHT POLES AND FLOODLIGHTS ARE TO BE DISCONNECTED AND REMOVED. ALL LUMINAIRES THAT ARE REMOVED ARE TO BE PRESENTED TO THE WESTERN SYDNEY UNIVERSITY FOR RE-USE/ARCHIVAL PURPOSES. IF RE-USE/ARCHIVING IS NOT DESIRED, THEN THE LUMINAIRES ARE TO BE RECYCLED/DISPOSED OF APPROPRIATELY.
2. ALL LIGHTING IS TO BE CONTROLLED VIA AN ADAPTIVE CONTROL SYSTEM CONTROLLED VIA TIMER, PE CELL, AND PIR (PASSIVE INFRARED MOTION) SENSOR. THE SYSTEM IS TO REGULATE THE LEVEL OF ILLUMINANCE ACCORDING TO THE TIME, LEVELS OF NATURAL LIGHT, AND ACTIVITY PRESENT WITHIN THE CARPARKS. REFER TO THE ADJACENT NOTES AND SPECIFICATION FOR THE FUNCTIONAL DESCRIPTION.
3. LIGHTING WITHIN THE CARPARKS IS TO MEET THE RELEVANT REQUIREMENTS OF AS/NZS 1158.3.1:2020. MORE SPECIFICALLY THE LIGHT TECHNICAL PARAMETERS FOR OUTDOOR CAR PARKS (REFER TO TABLE 3.7).
4. POLE POSITIONS TO BE COORDINATED BY CONTRACTOR WITH FINAL SET-BACK IN ACCORDANCE WITH AS/NZS 1158 AND TTW'S REQUIREMENTS. TO BE MINIMUM 500MM FROM ANY STORMWATER SERVICES. REFER TO TTW FOR KERBROAD DETAIL. POLE LOCATIONS ARE INDICATIVE ONLY AND DEMONSTRATE THE POSITIONS THAT PROVIDE COMPLIANCE WITH THE LTTPS OF AS/NZS 1158. CONTRACTOR TO COORDINATE EXACT AND FINAL SET OUT AND SET BACK OF POLES. CONTRACTOR TO ALLOW FOR MODIFICATION OF POLE AND PROVISION OF AN OUTREACH ARM IN THIS COORDINATION.
5. CONTRACTOR TO PROVIDE SHOP DRAWINGS OF FINAL ARRANGEMENT OF EACH POLE TYPE FOR APPROVAL.
6. REFER TO ELECTRICAL DOCUMENTATION FOR ALL ELECTRICAL CONNECTION DETAILS AND RETICULATION. FOOTING DETAILS ARE INDICATIVE ONLY. FINAL DETAIL TO MANUFACTURERS REQUIREMENTS/ ENGINEERS SPECIFICATION TO SUIT SITE CONDITIONS INCLUDING SOIL, WIND AND NEW CIVIL WORKS.

LIGHTING CONTROL AND FUNCTIONAL DESCRIPTION:

1. ALL LIGHTING IS TO BE CONTROLLED VIA AN ADAPTIVE CONTROL SYSTEM CONTROLLED VIA TIMER, PE CELL/PHOTOCELL, AND PIR (PASSIVE INFRARED MOTION) SENSORS. THE SYSTEM IS TO REGULATE THE LEVEL OF ILLUMINANCE ACCORDING TO THE TIME, LEVELS OF NATURAL LIGHT, AND ACTIVITY PRESENT WITHIN THE CARPARKS.
2. ALLOW FOR ALL LIGHTING TO BE CONNECTED TO A RELAY OR RELAYS TO ALLOW FOR THE LOAD TO BE COMPLETELY TURNED OFF. REFER TO THE ELECTRICAL DOCUMENTATION.
3. THE SYSTEM SPECIFICATION IS TO BE FINALISED BY THE CONTRACTOR WITH THE MANUFACTURER AND SUPPLIER OF THE LUMINAIRES. KEY COMPONENTS INCLUDING BUT NOT LIMITED TO A CONTROL INTERFACE SOLUTION IF REQUIRED, TIMECLOCK, NEMA SOCKET FOR A DAYLIGHT SENSOR/PHOTO CELL, ZHAGA SOCKET FOR A PIR SENSOR, DIMMERS, CONTROLLERS, RELAYS, AND RELAY CONTROLS.
4. LIGHTING WITHIN THE CARPARKS IS TO MEET THE RELEVANT REQUIREMENTS OF AS/NZS 1158.3.1:2020. MORE SPECIFICALLY THE LIGHT TECHNICAL PARAMETERS FOR OUTDOOR CAR PARKS (REFER TO TABLE 3.7). REFER TO THE BELOW FOR THE LIGHTING FUNCTIONAL DESCRIPTION THAT IS TO BE PROGRAMMED (FINAL SETTINGS TO BE CONFIRMED IN COMMISSIONING):
 - SUNRISE-11PM** (SUBCATEGORY: PC2)
NIGHT-TIME VEHICLE AND/OR PEDESTRIAN MOVEMENTS - MEDIUM
FEAR OF CRIME - MEDIUM
LIGHTING TO BE TRIGGERED ON WHEN LIGHT LEVELS ARE LOW BY PE CELL (OR IF NOT TRIGGERED AT TIME OF SUNSET, TRIGGERED ON VIA TIMER).
 - 11PM-1AM** (SUBCATEGORY: PC3)
NIGHT-TIME VEHICLE AND/OR PEDESTRIAN MOVEMENTS - LOW
FEAR OF CRIME - LOW
LIGHTING TO DIM DOWN TO PC3 LEVELS, TRIGGERED ON VIA TIMER.
IF MOVEMENT IS DETECTED BY A PIR SENSOR, THE LIGHT WILL RAMP BACK UP (OVER 3 SECONDS) TO PC2 LEVELS FOR A PERIOD OF 15 MINUTES, AFTER WHICH, IF NO FURTHER MOVEMENT IS DETECTED, THEY WILL DIM BACK DOWN TO PC3 LEVELS.
 - 1AM-SUNRISE**
LIGHTING TO TURN OFF, TRIGGERED ON VIA TIMER.
DURING THIS PERIOD THE CARPARK IS CONSIDERED CLOSED AND BY SWITCHING THE LIGHTS OFF THIS SIGNALS THE CARPARK IS NOT INTENDED FOR USE.
IF MOVEMENT IS DETECTED BY A PIR SENSOR, THE LIGHT WILL RAMP BACK UP (OVER 3 SECONDS) TO PC3 LEVELS FOR A PERIOD OF 15 MINUTES, AFTER WHICH, IF NO FURTHER MOVEMENT IS DETECTED, THEY WILL TURN OFF.

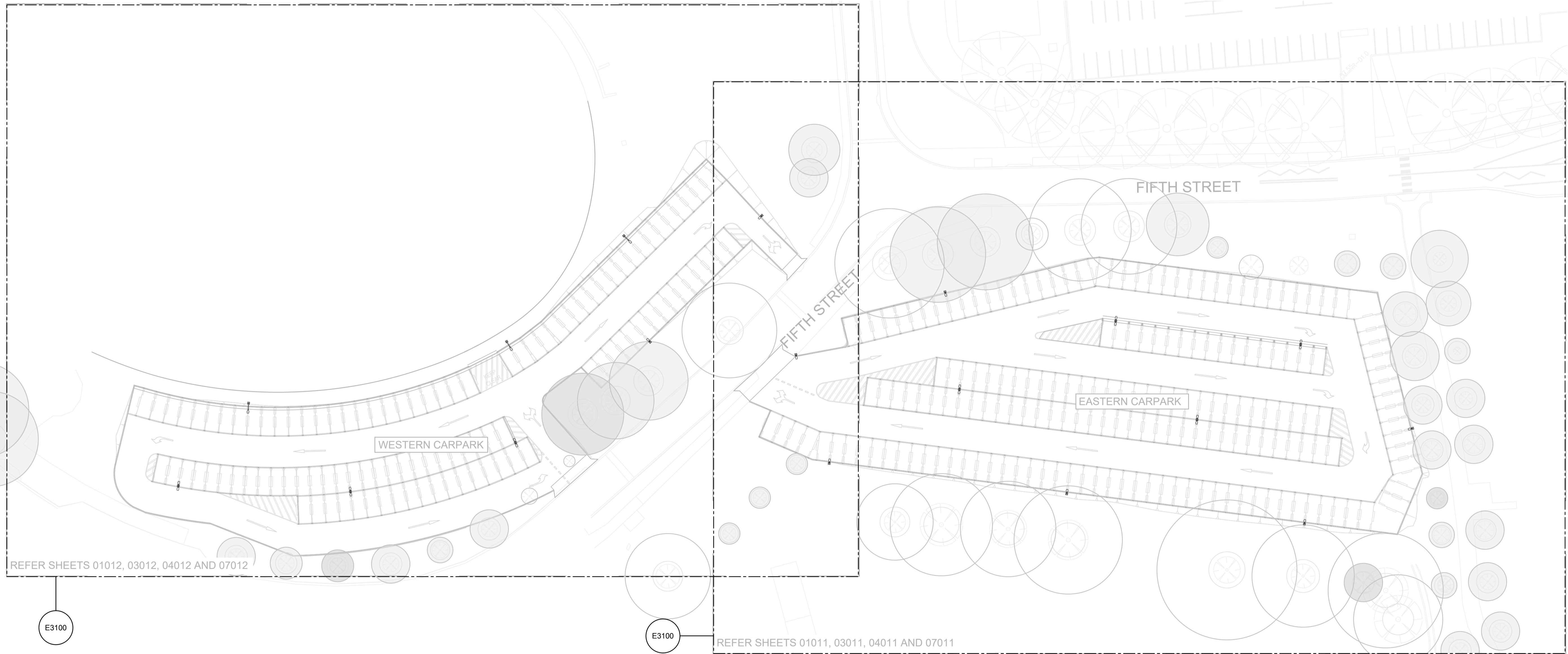

FOR TENDER
THIS IS NOT A WORKSHOP DRAWING
NOT FOR CONSTRUCTION. IT IS THE CONTRACTORS RESPONSIBILITY TO PROVIDE CONSTRUCTIONAL DIMENSIONED WORKSHOP DRAWINGS IN ACCORDANCE WITH THE RELEVANT SECTIONS IN THE SPECIFICATION.

DESIGNED UNDER QUALITY SYSTEM CERTIFIED AS COMPLYING WITH ISO 9001 BY AN ACCREDITED CERTIFICATION BODY
© Copyright. This Document and Design remains the copyright of Steensen Varming (Australia) Pty Ltd and cannot be reproduced in any way without prior consent. The contractor shall verify all dimensions and levels on site as this is not a workshop drawing. The contractor shall refer any discrepancies to the engineer before proceeding with the work. This drawing shall be read in conjunction with other contract documents, drawings and project specifications. This file has been checked by an antivirus program with the latest updates. However, new viruses are discovered everyday we recommend that this file is rescanned upon receipt.

AMENDMENTS		
REV	DESCRIPTION	DATE
A	FOR TENDER	04/10/24
B	FOR TENDER	27/06/25

Copenhagen
London
Sydney
Hong Kong
New York

8, 9 Castlereagh St.
Sydney, NSW, 2000, Australia
ABN 50 001 189 037
t : +61 / 02 9967 2200
e : info@steensenvarming.com

STEENSEN VARMING

PROJECT
WSU TEMPORARY CARPARK
FIFTH STREET, PARRAMATTA NSW 2116

DRAWING TITLE
ELECTRICAL SERVICES AND LIGHTING
LIGHTING SITE PLAN

CREATED	DRAWN	DESIGNED	CHECKED	APPROVED	SCALE
JUN'25	MS	MS	SS	SS	1:400
NORTHPOINT	PROJECT No.	DRAWING No.	REVISION		
	247150	SV_E3000	B		

B

A1

FOR TENDER

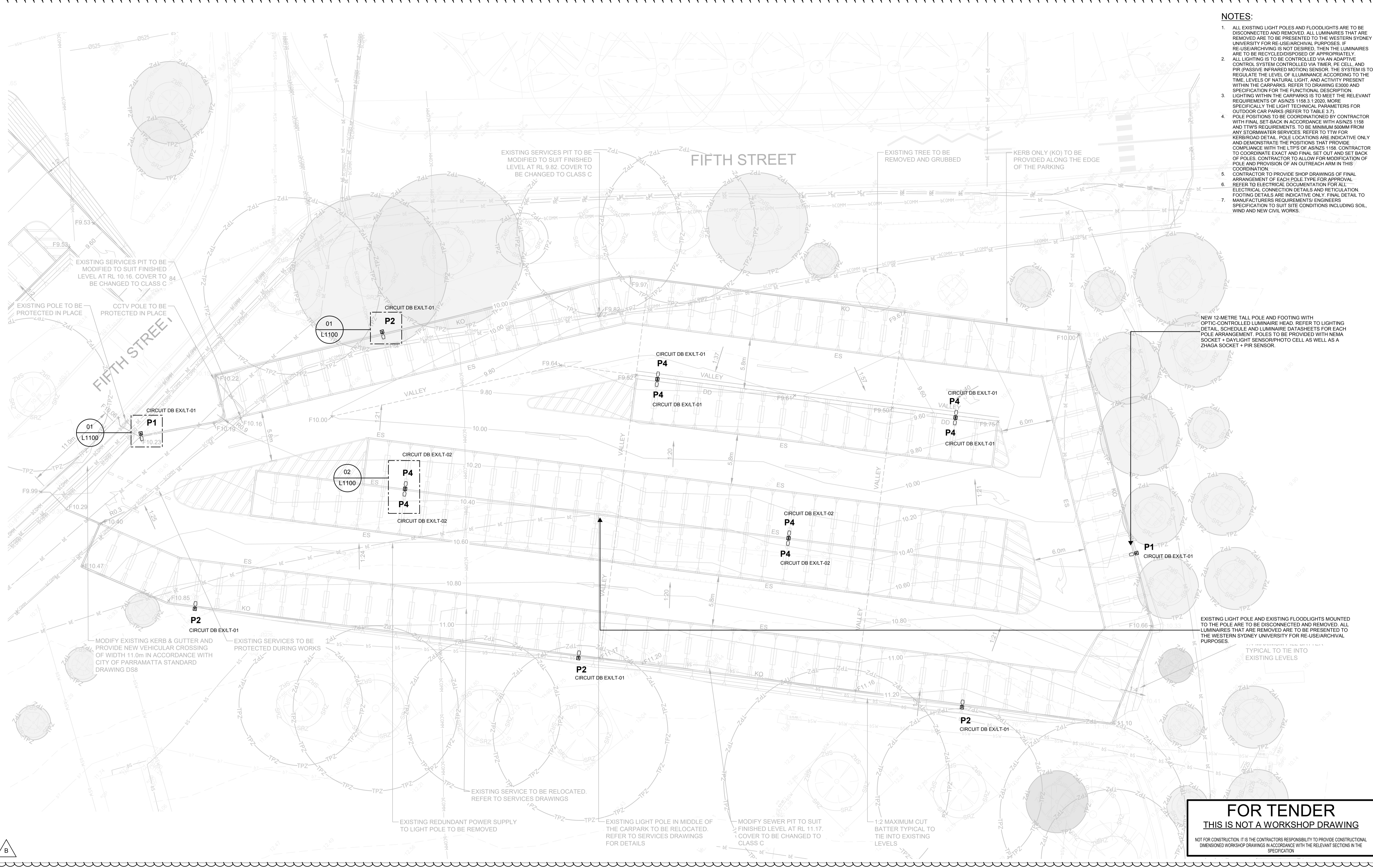

- NOTES:**
- ALL EXISTING LIGHT POLES AND FLOODLIGHTS ARE TO BE DISCONNECTED AND REMOVED. ALL LUMINAIRES THAT ARE REMOVED ARE TO BE PRESENTED TO THE WESTERN SYDNEY UNIVERSITY FOR RE-USE/ARCHIVAL PURPOSES. IF RE-USE/ARCHIVING IS NOT DESIRED, THEN THE LUMINAIRES ARE TO BE RECYCLED/DISPOSED OF APPROPRIATELY.
 - ALL LIGHTING IS TO BE CONTROLLED VIA AN ADAPTIVE CONTROL SYSTEM CONTROLLED VIA TIMER, PIR CELL, AND PIR (PASSIVE INFRARED MOTION) SENSOR. THE SYSTEM IS TO REGULATE THE LEVEL OF ILLUMINANCE ACCORDING TO THE TIME, LEVELS OF NATURAL LIGHT, AND ACTIVITY PRESENT WITHIN THE CARPARKS. REFER TO DRAWING E3000 AND SPECIFICATION FOR THE FUNCTIONAL DESCRIPTION.
 - LIGHTING WITHIN THE CARPARKS IS TO MEET THE RELEVANT REQUIREMENTS OF AS/NZS 1168.3:12020, MORE SPECIFICALLY THE LIGHT TECHNICAL PARAMETERS FOR OUTDOOR CAR PARKS (REFER TO TABLE 3.7).
 - POLE POSITIONS TO BE COORDINATED BY CONTRACTOR TO COORDINATE EXACT AND FINAL SET OUT AND SET BACK OF POLES. CONTRACTOR TO ALLOW FOR MODIFICATION OF POLE AND PROVISION OF AN OUTREACH ARM IN THIS COORDINATION.
 - CONTRACTOR TO PROVIDE SHOP DRAWINGS OF FINAL ARRANGEMENT OF EACH POLE TYPE FOR APPROVAL.
 - REFER TO ELECTRICAL DOCUMENTATION FOR ALL ELECTRICAL CONNECTION DETAILS AND RETICULATION. FOOTING DETAILS ARE INDICATIVE ONLY. FINAL DETAIL TO MANUFACTURERS REQUIREMENTS/ENGINEERS SPECIFICATION TO SUIT SITE CONDITIONS INCLUDING SOIL, WIND AND NEW CIVIL WORKS.

NEW 12-METRE TALL POLE AND FOOTING WITH OPTIC-CONTROLLED LUMINAIRE HEAD. REFER TO LIGHTING DETAIL, SCHEDULE AND LUMINAIRE DATASHEETS FOR EACH POLE ARRANGEMENT. POLES TO BE PROVIDED WITH NEMA SOCKET + DAYLIGHT SENSOR/PHOTO CELL AS WELL AS A ZHAGA SOCKET + PIR SENSOR.

EXISTING LIGHT POLE AND EXISTING FLOODLIGHTS MOUNTED TO THE POLE ARE TO BE DISCONNECTED AND REMOVED. ALL LUMINAIRES THAT ARE REMOVED ARE TO BE PRESENTED TO THE WESTERN SYDNEY UNIVERSITY FOR RE-USE/ARCHIVAL PURPOSES.

FOR TENDER
THIS IS NOT A WORKSHOP DRAWING
 NOT FOR CONSTRUCTION. IT IS THE CONTRACTORS RESPONSIBILITY TO PROVIDE CONSTRUCTIONAL DIMENSIONED WORKSHOP DRAWINGS IN ACCORDANCE WITH THE RELEVANT SECTIONS IN THE SPECIFICATION.

DESIGNED UNDER QUALITY SYSTEM CERTIFIED AS COMPLYING WITH ISO 9001 BY AN ACCREDITED CERTIFICATION BODY

© Copyright. This Document and Design remains the copyright of Steensen Varming (Australia) Pty Ltd and cannot be reproduced in any way without prior consent. The contractor shall verify all dimensions and levels on site as this is not a workshop drawing. The contractor shall refer any discrepancies to the engineer before proceeding with the work. This drawing shall be read in conjunction with other contract documents, drawings and project specifications. This file has been checked by an antivirus program with the latest updates. However, new viruses are discovered everyday we recommend that this file is rescanned upon receipt.

AMENDMENTS		
REV	DESCRIPTION	DATE
A	FOR TENDER	04/10/24
B	FOR TENDER	27/06/25

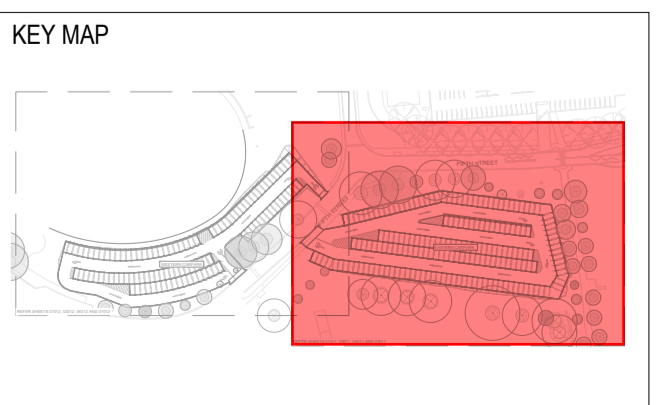

Copenhagen
 London
 Sydney
 Hong Kong
 New York

8, 9 Castlereagh St.
 Sydney, NSW, 2000, Australia
 ABN 50 001 189 037
 t: +61 / 02 9967 2200
 e: info@steensenvarming.com

STEENSEN VARMING

PROJECT
WSU TEMPORARY CARPARK
FIFTH STREET, PARRAMATTA NSW 2116

DRAWING TITLE
ELECTRICAL SERVICES AND LIGHTING
LIGHTING LAYOUT - SHEET 1

CREATED	DRAWN	DESIGNED	CHECKED	APPROVED	SCALE
JUN'25	MS	MS/MM	SS/IM	SS	1:200

NORTHPOINT	PROJECT No.	DRAWING No.	REVISION
	247150	SV_E3100	B

FOR TENDER

A1

When I'm working on a problem,
I never think about beauty. I think
only how to solve the problem. But
when I have finished, if the solution
is not beautiful, I know it is wrong.
Richard Buckminster Fuller

Mechanical Engineering
Lighting Design
Sustainable Design
Electrical Engineering

e : info@steensenvarming.com

ELECTRICAL AND LIGHTING SERVICES

STEENSEN VARMING

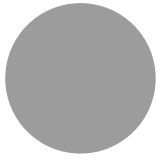

Western Sydney University Temporary Carpark Electrical and Lighting Services Specification



When I'm working on a problem,
I never think about beauty. I think
only how to solve the problem. But
when I have finished, if the solution
is not beautiful, I know it is wrong.
Richard Buckminster Fuller

Mechanical Engineering
Lighting Design
Sustainable Design
Electrical Engineering

e : info@steensenvarming.com

STEENSEN VARMING

Document Revision and Status

Date	Rev	Issue	Notes	Checked	Approved
04.10.2024	A	For Tender		SS/IM	SS
27.06.2025	B	For Tender	All changes indicated in red	SS/IM	SS

Sydney June 27th, 2024
Ref. No. 247150 - SPEC L01

Matthew Saunders
Lighting Designer

matthew.saunders@steensenvarming.com
+61 02 9967 2200

Manoj Matthew
Senior Electrical Engineer

manoj.matthew@steensenvarming.com
+61 02 9967 2200

Simm Steel
Associate

simm.steel@steensenvarming.com
+61 02 9967 2200

Disclaimers and Caveats:

Copyright © 2025, by Steensen Varming Pty Ltd.

All rights reserved. No part of this report may be reproduced or distributed in any form or by any means, or stored in a database or retrieval system, without the prior written permission of Steensen Varming Pty Ltd.

This document is confidential and contains privileged information regarding existing and proposed services for the Building. The information contained in the documents is not to be given to or discussed with anyone other than those persons who are privileged to view the information. Privacy protection control systems designed to ensure the highest security standards and confidentiality are to be implemented. You should only re-transmit, distribute, or commercialise the material if you are authorised to do so.

When I'm working on a problem,
I never think about beauty. I think
only how to solve the problem. But
when I have finished, if the solution
is not beautiful, I know it is wrong.
Richard Buckminster Fuller

Mechanical Engineering
Lighting Design
Sustainable Design
Electrical Engineering

e : info@steensenvarming.com

STEENSEN VARMING

Table of Contents

1.0	Project Particulars	5
1.1	Introduction	5
1.2	The Project	5
1.3	Definitions	6
2.0	General	7
2.1	Objectives, Roles, and Expectations	7
2.2	Related Documents	8
2.3	Design Requirements	9
2.4	Coordination Responsibility	9
2.5	Co-Operation / Co-Ordination	10
2.6	The Scope of Works	10
2.7	Obvious Work	11
2.8	Work Associated with Services	11
2.9	Survey Works	12
2.10	Timing Related Issues, Temporary Works and Continuity of Operations	12
2.11	Interruption of Existing Services	13
2.12	Redundant Equipment	13
2.13	Aesthetics	14
2.14	Labelling	14
2.15	Seismic Provisions	14
2.16	Corrosive Environments	15
3.0	Codes and Regulations	16
3.1	Conformity with Codes and Regulations	16
3.2	Workplace Health and Safety (WH&S), Service Aisles, Walkways and Access Spaces	18
4.0	Drawings and Technical Submittals	19
4.1	Contractor's Deliverables Register	19
4.2	Inspections and Hold Points / Tests	20
4.3	Contractor's Drawings	20
4.4	Samples	21
4.5	Electronic Submittal Procedures	22
4.6	Contractor's Drawing Definitions	22
4.7	Operating and Maintenance Manual	24
4.8	Preventative Maintenance	29
5.0	Electrical	30
5.1	Scope of Work	30
5.2	Aesthetics	31
5.3	Existing Spare Breakers	31
5.4	Proposed Lighting Sub-Circuiting	32
5.5	Cabling and Containment	33
5.6	Penetrations	34

When I'm working on a problem,
I never think about beauty. I think
only how to solve the problem. But
when I have finished, if the solution
is not beautiful, I know it is wrong.
Richard Buckminster Fuller

Mechanical Engineering
Lighting Design
Sustainable Design
Electrical Engineering

e : info@steensenvarming.com

STEENSEN VARMING

6.0	Lighting - General	35
6.1	Lighting Intent	35
6.2	General	35
6.3	Workshop Drawings	36
6.4	Equipment Selection	36
6.5	Spares and Contingency	36
6.6	Light Sources (LED)	37
6.7	Control Gear	37
6.8	Installation of Luminaires	38
6.9	Location	39
6.10	Supports	39
6.11	Samples	40
6.12	Alternatives	40
6.13	Hold Points/ Tests	42
7.0	Lighting Control	43
7.1	Operation	43
7.2	Circuiting	44
7.3	Light Switches	44
7.4	Labelling of Lighting Controls	44
7.5	Dimmers, Relays, and Controls	44
8.0	Lighting Commissioning	45
8.1	Pre-commissioning	46
8.2	System testing	47
8.3	Commissioning	47
8.4	Final Checks	48

1.0 Project Particulars

1.1 Introduction

This specification forms part of the contract documents.

This specification provides:

- A general description of the works in general terms and to specify general conditions and requirements for their execution, including sub-contracting, approvals, testing and completion.
- A general description of the project, the design intent, and provide an understanding of the systems and performance requirements documented in the specification and drawings with an outline of what is required of the Contractor in their interpretation of the documents, their implementation and construction of the works and the outcomes required in completing the project.

Provision should be made for compliance with all sections of this document.

The specification must be read together with

- the luminaire data sheets.
- the associated lighting and electrical drawings.

1.2 The Project

The project is the construction of relocated car parking facilities located at Fifth Street, within the Western Sydney University, Parramatta South Campus. The specific works to relocate the Car Park P1 at the Parramatta South Campus involves site establishment works (laybacks and temporary fencing), tree removal, earthworks, stormwater and civil activities, pavement works and minor landscaping works, hard stand paving and line marking for 320 cars; and signage and lighting.

A key objective of the lighting (and associated electrical works) as detailed in this specification is to enhance the car-park presence and identity for the night-time experience by providing a safe environment for pedestrian and vehicular traffic and recognising the need for specific guidelines, environmental considerations, and visual comfort.

The existing light pole and floodlights mounted to this pole are to be disconnected and removed. The new lighting design will consist of 9-metre-high poles and optic-controlled luminaires, with a warm-white colour temperature. This solution ensures compliance with the required illuminance levels and uniformity of AS/NZS 1158.3.1:2020. The design will utilise an intelligent, adaptive lighting controls that can minimise energy consumption, extend the life cycle of the luminaires, and reduce the obtrusive effects of outdoor lighting.

A high level of detail, co-ordination and consideration is required for the installation of the lighting and electrical components, particularly where lighting is located adjacent stormwater services. Detailed co-ordination and shop drawings are required.

The Contractor is responsible for the lighting installation, mounting details, lighting control upgrades, programming, and all associated electrical works. The works will be completed on site in stages to align with the temporary carpark works and as identified in the Head Contract. The Contractor is to liaise with the Principal and head contract for programme and staging requirements.

1.3 Definitions

In interpreting this section, the following words shall have the meaning assigned to them below:

Approved or Approval:	means approval by, or to the approval of, the Principal's Authorised Person and/or all relevant Authorities.
Authorities:	means any authority having jurisdiction over the works
Consultant:	means Steensen Varming (Australia) Pty Ltd.
Contract	The agreement between the Contractor and the Principal constituted by the Contract Documents.
Contract Documents	The documents described as such in the Contract together with: This specification; Completed Tender Return Schedules; Associated Drawings (including equipment schedules); Electrical Design Documentation.
Contractor:	means the organisation, engaged by the Principal or Managing Contractor to undertake the works.
Drawings:	means the services drawings listed in this specification and other drawing referred to in the Contract Documents.
Principal:	means Western Sydney University (WSU) or their nominated representative.
Project	means the new lighting (and associated electrical works) as part of the new WSU temp. carpark
Specialist Sub -Contractor	means the organisation engaged by the Contractor or Sub-Contractor to undertake specialist services, other than a Consultant or a Supplier.
Sub-Contractor:	means the organisation engaged by the Contractor to undertake the services works, other than a Consultant or a Supplier.

2.0 General

Prior to commencing the works, the Contractor shall ensure it is familiar with the contract documents, including the drawings and specification and all other associated documents. The Contractor shall notify the Principal's Authorised Person of any work or material shown or specified in these documents which in its opinion will not give satisfactory results.

It should be noted that the drawings are indicative of the design and not show exact measurements and all the services details. The Contractor shall utilise structural and architectural drawings as well as those provided by specialist contractors as well as site measurements for accurate assessment and measurement.

All equipment and services shall be coordinated with the site, the carpark finishes, function, other consultant advice, and other services and to the approval of the Principal's Authorised Person.

Any inconsistency between the drawings and the specification or in either document separately shall be reported to the Principal's Authorised Person by the Contractor before any work is commenced. The Principal's Authorised Person will decide the course of action to be followed.

Any items either shown on drawings or described in specification are deemed to be included.

2.1 Objectives, Roles, and Expectations

A number of objectives have been established to ensure the success of the project. Notwithstanding the information detailed in the Design Documents, Contract and User Briefing information, the following are key lighting and electrical services requirements to be given equal significance, careful consideration and intelligent integration into the design finalisation, coordination, and installation of the works for the new carpark.

Services are to be provided:

- That enhance the carpark presence and identity for the nighttime safety.
- To ensure safe, comfortable, and pleasant experience to users (without glare and discomfort).
- That are sensitive to the external environment.
- With controls that are can be set and forget, and can be modified by staff.
- With an appropriate level of technology which have been tried and tested.
- To be coordinated and integrated with the civil works and other engineering services disciplines both new and existing.
- To comply to all relevant legislation, standards, codes, and guidelines that are appropriate and relevant to the type of installation or equipment.
- That are appropriately sized.
- To be routed and arranged in an organised and systematic manner.
- To ensure value for money in terms of capital cost and recurrent costs.
- To be energy efficient and in accordance with best practice.

- That are easy to maintain inclusive of the necessary flexibility and versatility to allow isolation, shutdown and removal of equipment and systems as required for servicing or removal and replacement.

The Contractor shall possess relevant specialist expertise and experience in the type, scale, and complexity of work necessary to complete the works.

The Contractor shall read and note all clauses in the General Requirements of Contract and Annexure and preliminaries as applicable to its trade.

The Contractor shall provide all equipment, labour, and materials to complete the works and co-ordinate and co-operate with all other trades associated with its trade work.

The Contractor shall:

- Raise any issues requiring design input or clarification, in time to allow it to meet the contract program, particularly in respect to:
 - Interpretation of the specification or drawings;
 - Problems in complying with the specification;
 - Omissions from the construction documents;
 - Suggested alternatives / substitutions.
- Certify compliance with contract documents, including all variation instructions, at completion;
- Certify compliance with all Authority requirements;
- Pay all fees and charges associated with meeting statutory and Authority requirements;
- Obtain all Authority permits and certificates in a timely manner to allow the progress of the work in accordance with the contract program;
- Implement procedures to ensure that only competent tradesmen are used for the works;
- Be cognisant of the role of all relevant parties during the construction phase of the project and to assist them in the conduct of their duties wherever possible;
- Contribute, in the spirit of partnering, towards the successful execution of the Project;
- Provide manufacturers and construction drawings;
- Provide samples and prototypes where specified or appropriate;
- Make final equipment selections where required (including brackets, accessories, conduits, etc.) to meet the requirements specified;
- Stage the works as agreed with the Principal or the Principal's Authorised Person, to ensure the full functionality of the space.

2.2 Related Documents

This specification and associated drawings shall be read in conjunction with all other contract and reference documents, including but not limited to the following:

- Electrical and lighting design drawings (Issued for Tender);
- Civil engineer's drawings and specifications;
- All other relevant documents to the project.

2.3 Design Requirements

The Contractor is responsible for all the design. Due to the nature of the project services the specifications and documents show indicative design requirements and the Contractor has a role in carrying these design requirements and principles forward to finalisation through the design process including but not limited to:

- Site investigations to confirm site conditions, cable penetration and reticulation;
- Coordination of pole locations with the requirements of the relevant Australian Standards and WSU requirements;
- Confirmation of design calculations;
- Design documentation and equipment selection;
- Final coordination with all trade services, and;
- The functional requirements.

A suitable Contractor must be employed to complete all design works and be actively present in the verification and checking process on site during installation.

By submitting a tender for this project, the Contractor is expected to have acquainted themselves with all the tender documents and fully understand the design intent of all systems for the project, in terms of programme, performance outcome, aesthetics, heritage considerations, energy capacity, redundancy, buildability and environmental impacts and life expectancies.

It is a requirement of this specification that the Contractor presents a statement of understanding as part of their tender submission to illustrate that they fully understand the design intent of the tender documents.

The Contractor is required to understand and acknowledge that due to the nature of the services and procurement method that tender documents show design intent in principle and the Contractor has the role in carrying these principles forward to design finalisation through the completion of the detailed design, confirmation of equipment selection, coordination, logistics in disconnections and connections and implementation.

2.4 Coordination Responsibility

The Contractor is responsible for coordination at both the coordinated workshop drawing stage and onsite installation stage.

In the process of preparing coordinated workshop drawings, the Contractor acknowledges that Contract drawings have been drawn to show design in principle and is required to develop from these principles detailed workshop drawings, taking into account the civil design, actual site conditions, structure, installation and access requirements and coordination with other sub-contractors and their coordinated workshop drawings. The Contractor is deemed to have allowed for this exercise and any necessary deviation of routes from the Contract drawings that may be required as a result of this exercise.

At the installation stage, the Contractor is required to coordinate both in spatial terms with the civil works, structure, and other trades to confirm their respective

coordinated workshop drawings and also in respect of sequence of installation to ensure that all trades and services can be installed in accordance with coordinated workshop drawings. The Contractor is deemed to have allowed for this exercise and any necessary deviations from the workshop drawings that may occur in this exercise.

2.5 Co-Operation / Co-Ordination

Works on the site executed under other contract(s) may be proceeding concurrently with the works included in this contract. The Contractor shall co-operate as necessary with all other contractors and with each firm to whom part or parts of the contract works are sub-let.

The Contractor shall be responsible for co-ordination with all trades to ensure that all services are accommodated satisfactorily, particularly in voids and cavities. Details of other services, etc. should be obtained from the Principal's Authorised Person and the relevant trade.

It is specifically noted that;

- The pole footings will need to be coordinated with a structural engineer and the civil engineer, including coordination with the stormwater and drainage solutions
- all works to be approved and co-ordinated with the client,
- contractor is to coordinate with all other services cabling and pipework when installing cable routes from luminaires to switchboards,
- control connections to the existing building management system.

2.6 The Scope of Works

The extent of works includes the design finalisation, supply, delivery, installation, commissioning, testing, certification, and warranty of the services as specified and indicated on the drawings and specification.

The extent of work includes but not limited to the following:

- Detailed trade survey of the existing electrical conduits & electrical pits supporting the area and provision of record documentation;
- Removal and return to WSU of all the existing lighting;
- Testing and Labelling existing spare 250A circuit breakers;
- Modifications and changes to the existing circuits and switchboard to address any code issues such as the need for RCD protection;
- Installation of new HDPE conduits utilising existing electrical pits and addition of new electrical pits, if necessary;
- New circuits to support the new lighting as needed;
- Provision of Switchboard Schedules;
- Investigation and nomination of possible cable routes from nominated switchboards to luminaires for review and installation;
- Coordination of existing services with the design with proposed works;
- Coordination with structural, civil works, and other services;

- Containment cable supports, conduits, and cable containment for electrical, and communications works;
- Cables, wiring systems where necessary to AS/NZS3000;
- Power for other trades as required;
- External lighting in line with design documentation;
- Luminaires including lamps and control gear, accessories, mounting systems and block outs;
- Lighting control systems;
- Updating of lighting control head end details;
- Investigations and site measurements outlined in the documents;
- Samples (in working condition);
- Shop Drawings;
- Equipment selection datasheets;
- Labelling and Identification;
- Testing and commissioning;
- As-builts;
- Operation and user manuals;
- Training;
- Warranty for installation and equipment;
- 12 months defects liability;
- 12 months preventative maintenance.
- Obvious Work (refer below).

2.7 Obvious Work

Obvious Works includes all works and equipment of a minor nature not specifically mentioned but necessary for the operation of the specified equipment and systems.

If neither the specification nor plans contain any mention of minor parts which in the opinion of the Principal's Authorised Person are reasonably and obviously necessary for the satisfactory completion of the contract works such parts shall be provided by the Contractor without any additional charge or cost.

2.8 Work Associated with Services

These lists are provided to assist the Contractor and their trades at interface points and do form part of the Contractor's scope unless noted otherwise.

2.8.1 Building Trade

- All permanent access openings and removable access panels in ceilings, walls, shafts etc.
- Cut-outs in finished surfaces for electrical lights and equipment (set out and marking by electrical trade in line with requirements set out in lighting and heritage architect's documentation);
- Provisions for rubbish collection regular rubbish removal from site;
- Plinths, hobs, and block-outs;
- Structural supports for equipment;

- Penetration through floors, ceiling, walls and roof for pipework, conduits, cables, sleeves, etc. and make good around all penetrations after installation. Seals to all penetrations. All building penetrations to be approved by heritage architect;
- All modifications to building and heritage fabric as required for new luminaires and all patching and making good. Work method statement for works to minimise impact to heritage fabric;
- Internal and external scaffolding and special access equipment for services above and below 3m in height;
- Provision of 400/230 volts, 4-wire power for trade's use in operation of hand tools, welding equipment;
- Provision of 400/230 volts, 4-wire power for testing of the plant, also outlets for temporary lighting;
- Making good after chasing, core drilling and placing of sleeves etc.;
- Plinths, footings, hobs, and block-outs. Steel set out and fixing of footings and plinths only. (assumed concrete by builder trade);

2.9 Survey Works

The Contractor shall undertake a site survey prior to commencement of works to verify all matters that could affect contract costs of works. No variations will be accepted post contract documentation costing for any omission of works or cost arising from information available at the time of contract document submission.

The Contractor shall arrange and provide for all specialist surveys to be undertaken if required over and above those undertaken by the Principal and forward the results of these to the principle's representative prior to submitting "for comment" the associated Contractor drawings and technical submittals.

The specialist surveys may include but not limited to the following:

- Luminaire mounting positions and lengths,
- Existing (including verification) and proposed cable penetration, sizes and reticulation routes,
- Wall cavity size, accessibility, and feasibility for reticulation,
- Other surveys as identified within the Head Contract.

2.10 Timing Related Issues, Temporary Works and Continuity of Operations

The Contractor shall ensure that all services remain operational during the works (with exception of any pre-determined down times agreed with the Principal's Authorised Person). Sequencing and programming of the works will be critical in order to minimise the disturbance during normal operational hours (as defined on the Contract). Detailed programme indicating sequencing and highlighting critical works shall be provided by the Contractor prior to commencement on site and shall be to the satisfaction of the Principal's Authorised Person.

The Contractor shall ensure that all new and existing equipment that operates throughout the duration (or part thereof) of the installation works will be fully protected from damage at all times and will be kept clean and free from dust and

debris. Following completion of the works, the Contractor shall ensure that all new and existing equipment be cleaned and to the satisfaction of the Principal's Authorised Person.

The Contractor shall ensure that during any construction/ demolition works all luminaires are sealed or protected as necessary to prevent any dirt or dust ingress into the systems.

The Contractor shall provide detailed staging drawings (including layouts, sections, and schematics) and detailed method statements for all temporary works proposals that are required to ensure that the above requirements and responsibilities are appropriately discharged. These proposals shall be approved by the Principal's Authorised Person prior to any work being carried out. The Contractor shall include preliminary versions of this information is within the tender submissions for this project.

2.11 Interruption of Existing Services

Where the work under the contract affects the continuity of existing services the Contractor shall arrange to have the work carried out at the least inconvenient time to the Principal as advised by the Principal's Authorised Person. The work shall be organised to minimise the duration of inconvenience. This will mean out of hours work will need to be undertaken for elements of the Work.

No existing services are to be interrupted, disconnected, or removed until a new replacement service has been fully installed and commissioned, unless specific approval has been given by the Principal's Authorised Person.

The Contractor is deemed to have understood that some of the Works are to be carried out within an existing building and as such all care shall be taken to avoid disruption to the facility or its systems.

All work involved in the interruption of existing services will be carried out by arrangement with the Principal's Authorised Person.

The Contractor shall submit for review a detailed program of the Works contained in this specification indicating all testing, installation, shutdowns, cut ins, changeovers, commissioning periods and anything else affecting the continued operation of the building and its systems.

2.12 Redundant Equipment

The Contractor shall remove from the site all equipment and services which are to be made redundant as part of the works. The redundant equipment shall be presented to WSU first for re-use/archival purposes. If it is to not be re-used or archived, it is to be disposed of by the Contractor. All effort shall be made to recycle redundant equipment associated with this Contract. The Contractor shall provide a waste management plan together with records of relevant disposal and recycling activities.

All redundant electrical and lighting equipment shall be removed. Redundant electrical services and control services shall be stripped back to source and associated ways in the distribution panels and shall be labelled as 'spare'.

2.13 Aesthetics

The Contractor is responsible for satisfying the Client's requirements and the aesthetic quality. Ensure there are no exposed services visible in public spaces line of sights. Provide services that minimise obtrusive equipment and services and provide elegant, concealed elements inclusive of all paint and special covers. Visible equipment should be architecturally aligned and symmetrically spaced where possible, co-ordinating new and existing services.

The aesthetic requirements for a neat, geometrically set out of the services extends to all areas of the project including external and back of house areas.

Services in cupboards, risers and the panels and equipment must be neatly and evenly fixed supported, laid out and reticulated in a geometrically manner.

An attention to detail and uniform layout of systems and services is a requirement. Untidy and messy design and installation works will be defected.

2.14 Labelling

Traffolyte or laser engraved laminate is to be used for labels for points and equipment in switchboards and new lighting control.

2.15 Seismic Provisions

The Contractor must design the services supports in accordance with AS1170.4, using the methodology described in Section 8. In carrying out the design of the supports, the Contractor must:

Refer to the NCC consultant report to obtain the building Importance Level;
Where the Importance Level is 4, design all services supports with an Importance Factor of 1.5;

Where the Importance Level is 1, 2, or 3:

- Design general component supports with an Importance Factor of 1;
- Design all components critical to life safety, which includes parts and components required to function immediately following an earthquake, those critical to the containment of hazardous materials with an Importance Factor of 1.5.

The Contractor must obtain the following information from the Structural Engineer in order to carry out the design:

- The probability factor;
- The hazard factor;

When I'm working on a problem,
I never think about beauty. I think
only how to solve the problem. But
when I have finished, if the solution
is not beautiful, I know it is wrong.
Richard Buckminster Fuller

Mechanical Engineering
Lighting Design
Sustainable Design
Electrical Engineering

e : info@steensenvarming.com

STEENSEN VARMING

- Site sub-soil class;
- Earthquake design category;
- Structural ductility factor;
- Structural performance factor.

2.16 Corrosive Environments

The electrical installation and equipment selection must be arranged and installed to ensure that they are suited the environment. Provide corrosion protection and materials suitable to the environment that they are located. Where two metals are in close proximity, metals to be the same or of the same galvanic series. If otherwise, metals to be suitably separated to ensure no galvanic corrosion.

3.0 Codes and Regulations

3.1 Conformity with Codes and Regulations

All works shall be carried in accordance with the appropriate Australian Standards, Codes and Regulations including:

3.1.1 Electrical:

- AS/NZS3000 SAA Wiring Rules and reference standards within.
- AS 3008.1 Electrical Installation – Selection of Cable
- AS/CA S009 Installation requirements for customer cabling (Wiring Rules)
- AS/CA S008 Requirements for customer cabling products
- AS/NZS IEC 61935.1 Specification for the testing of balanced and coaxial information technology cabling installed balanced cabling as specified in ISO/IEC 11801 and related standards (IEC 61935-1, Ed.3.0 (2009) MOD).
- AS/NZS 2967 Optical fibre communication cabling systems safety.
- AS/NZS 3835.1 Earth potential rise - Protection of telecommunications network users, personnel, and plant - Code of practice.
- AS/NZS 3835.2 Earth potential rise - Protection of telecommunications network users, personnel, and plant - Application guide.
- AS/NZS 61439 series of standards - Low Voltage Switchgear and Control Gear Assemblies;
- AS 1657 Fixed platforms, walkways, stairways, and ladders - Design, construction, and installation
- AS 1939 Supp 1 Degrees of protection provided by enclosures for electrical equipment (IP Code) - Wallchart 1
- AS 1939 Supp 2 Degrees of protection provided by enclosures for electrical equipment (IP Code) - Wallchart 2
- AS/NZS 2053.1 Conduits and fittings for electrical installations - General requirements
- AS/NZS 2053.3 Conduits and fittings for electrical installations - Rigid plain conduits and fittings of fibre-reinforced concrete material
- AS/NZS 2053.7 Conduits and fittings for electrical installations - Rigid metal conduits and fittings
- AS/NZS 61386.1 Conduit systems for cable management - General requirements
- AS/NZS 61386.21 Conduit systems for cable management - Particular requirements - Rigid conduit systems
- AS/NZS 61386.23 Conduit systems for cable management - Particular requirements - Flexible conduit systems
- AS/NZS 61439.1 Low-voltage switchgear and controlgear assemblies - General rules (IEC 61439-1, Ed. 2.0)
- AS/NZS 61439.2 Low-voltage switchgear and controlgear assemblies - Power switchgear and controlgear assemblies (IEC 61439-2, Ed. 2.0)
- AS/NZS 61439.3 Low-voltage switchgear and controlgear assemblies - Distribution boards intended to be operated by ordinary persons (DBO) (IEC 61439-3, Ed. 1.0)

- AS/NZS 61439.4 Low-voltage switchgear and controlgear assemblies - Particular requirements for assemblies for construction sites (ACS) (IEC 61439-4, Ed. 1.0)
- AS/NZS IEC61439.5 Low-voltage switchgear and controlgear assemblies - Assemblies for power distribution in public networks
- AS/NZS 61439.6 Low-voltage switchgear and controlgear assemblies - Busbar trunking systems (busways) (IEC 61439-6, Ed. 1.0)
- Managing electrical risks in the workplace: Code of Practice 2014, WorkCover NSW
- Construction work: Code of Practice 2014, WorkCover NSW
- Demolition work: Code of Practice 2014, WorkCover NSW
- Work near overhead power lines: Code of Practice 2006, WorkCover NSW
- General guide for working in the vicinity of overhead and underground electric lines 2014, Safe Work Australia
- AS 3012 Electrical installations – Construction and demolition sites
- AS 2601 The demolition of structures
- AS/NZS 3012:2010 Electrical installations - Construction and demolition sites

3.1.2 Lighting:

- AS/NZS 4051 EMC compliance
- AS/NZS 4783.2 Energy efficiency for ballasts and lamps
- AS/NZS 60598.2.1 Fixed general-purpose luminaires
- AS/NZS 61000.3.3 Harmonic Limits
- AS/NZS 60598.1 Luminaires, general requirements, and tests
- AS/NZS 3137 Luminaires
- AS/NZS 60598.1 Luminaires, general requirements, and tests
- AS/NZS CISPR 15 Radio interference limits
- IES LM-80-08 Measuring Lumen Maintenance of LED Light Source
- IES LM-79-08 Electrical and Photometric Measurements of Solid-State Lighting Products
- AS/NZS 3012:2010 Electrical installations - Construction and demolition sites
- AS/NZS 4282 Control of the obtrusive effects of outdoor lighting
- AS/NZS 1158.0 Lighting for roads and public spaces
- AS/NZS 1158.3.1 Lighting for roads and public spaces: Pedestrian area (Category P) lighting – Performance and design requirements

When I'm working on a problem,
I never think about beauty. I think
only how to solve the problem. But
when I have finished, if the solution
is not beautiful, I know it is wrong.
Richard Buckminster Fuller

Mechanical Engineering
Lighting Design
Sustainable Design
Electrical Engineering

e : info@steensenvarming.com

STEENSEN VARMING

3.2 Workplace Health and Safety (WH&S), Service Aisles, Walkways and Access Spaces

The Contractor is to ensure adequate space be provided for servicing of equipment and parts in ceiling spaces and the general areas. Equipment shall be installed to ensure adequate serviceability without the need for unsafe work practices.

Reference shall be made to:

- Manufacturer's installation instructions;
- WorkCover requirements;
- Australian/New Zealand Standards.

In locating equipment, the Contractor shall pay particular attention to furnishing easy access to it, in accordance with OH&S Act. The Contractor shall indicate all walkways and service areas around all items of equipment on drawings.

In the construction stage, all such access space shall be preserved, without interfering with passage.

The Contractor will be required to disassemble and reinstall any piping, supports or assemblies which interfere with the freedom of passage, at no extra cost. Where any doubt exists as to the adequacy and width of the passageway, verify the condition with the Superintendent before proceeding.

4.0 Drawings and Technical Submittals

The overall target completion date has not been specified in this Contract. It is the Contractor's responsibility to programme the work in a logical and realistic manner to achieve the target completion date as provide by the Superintendent. In this context, it is the requirement of this specification that the logical sequencing of events is maintained:

- Equipment submissions; (samples, literature, and prototypes)
- Equipment procurement/purchasing;
- Preparation and coordination of workshop drawings;
- Site coordination;
- Installation;
- Cleaning of equipment
- Testing and balancing/ adjusting
- Commissioning, including dynamic checking and verification of automatic control systems.

The above list is not intended to be exhaustive but to emphasise the sequence in which these key items should take place to avoid instances such as equipment being ordered prior to review thus leading to deviations from specification or coordination problems due to change in dimensions. Any unnecessary acceleration on the submission and review process due to events occurring out of sequence or delaying of some from the Contractor's initiative will not be accepted.

4.1 Contractor's Deliverables Register

Following Contract award, the Contractor shall prepare a register of all necessary Contractors' deliverables. This register shall be maintained as a "live" document throughout the contract until all items have been delivered. The register shall be issued on a regular basis (at least bi-weekly). This will include items such as technical submittal, sample review submissions and co-ordinated workshop drawings. The register will show planned dates for delivery of submissions for review by the consultants.

The Contractor acknowledges that certain equipment / co-ordinated workshop drawings / sample reviews require more time to review than others. Therefore, to enable the consultant to ensure resources are available to carry out reviews at the necessary time, the Contractor shall ensure that the planned review dates are advised with sufficient notice to enable the consultant to plan ahead. Any delays in reviews as a result of the review date information not been provided in time will be the Contractor's responsibility.

4.2 Inspections and Hold Points / Tests

There are a number of hold points and witness points during the construction phase of the project which may require inspection and verification by the client and architect. The Contractor shall provide sufficient notice (at least 2 weeks) to all relevant parties to attend inspections or for the review of submissions. Works shall not proceed without relevant authorisation. Refer to the relevant sections of this specification for details on submissions, inspections/witness, testing and commissioning.

Hold Points Include:

- Submission and Review of Samples;
- Submission and Review of Workshop Drawings;
- Submission and Review of Technical Data;
- Inspection and Review of Installation works as detailed below:
 - Work Method Statements for specific works considered sensitive or works that may have an impact on the functional operation of the facility or adjacent facilities;
 - Prior ceiling and wall sheeting;
 - Inspection before removal of access safety provisions or when certain areas are not to be accessible any more for other reasons;
 - Commissioning and Programming
 - Testing and Certification of all systems prior to Completion.

The above list is not intended to be exhaustive but to emphasise the sequence in which these key items should take place to avoid instances such as equipment being ordered prior to review thus leading to deviations from specification or coordination problems due to change in dimensions. Any unnecessary acceleration on the submission and review process due to events occurring out of sequence or delaying of some from the Contractor's initiative will not be accepted.

4.3 Contractor's Drawings

The Contractor is to provide complete manufacturing and installation Shop Drawings and all necessary technical data covering the Work under the Contract.

All drawings shall adhere to the following requirements:

Drawings are to be prepared in digital format and submitted to the Principal's Authorised Person in PDF as DWG/ CAD or Revit model format where required, and in accordance with the following requirements:

- Drawings are to be prepared in digital format and submitted to the Principal's Authorised Person in PDF;
- Prepare on DWG/ Revit base from architectural layouts of the latest agreed revision number;
- Provide drawings to the actual service and equipment layouts;
- Drawings shall include the set-out dimensions from columns and the building's architectural details;

- Internal penetration sizes shall be actual and should include correct clearances and the allowance for insulation, flanges cable trays and the like;
- External penetration sizes shall be actual and show setting out from architectural boundaries and details;
- Nominate the building element and material being penetrated;
- Submit all penetration layouts to the Principal's Authorised Person;
- Overlay internal penetrations with duct work, electrical cabling, fire services and water piping drawings for full coordination of ceiling services before submitting drawing for review;
- All Contractor's drawings for distribution shall be submitted by the Contractor in reproducible electronic format to the Principal's Authorised Person;
- All drawings shall be in accordance with the project specific and client guidelines, the version of which is current at the date of acceptance of this contract;
- Unless noted to the contract elsewhere, the Contractor's drawings scale should match the design documentation

Where necessary further copies of drawings shall be submitted to the appropriate authorities.

Drawings are required for:

- Manufacturer's drawings of purpose made equipment;
- Details of labelling and engraving;
- Switchboards;
- Lighting Control;
- Lighting Layouts and Lighting Controls SLDs;
- Sections and Details;
- Power layouts and SLDs.

Revised Contractor's drawings shall be submitted by the Contractor, if requested.

Refer to the Contractors Drawing Definitions section for further information on what is required for each drawing submission.

4.4 Samples

The Contractor shall submit for the review of the Principal's Authorised Person prior to commencing installation samples of all accessories, fitting and apparatus proposed to be used in the work and only such items as are approved may be installed. Samples to be submitted include but are **not** limited to the following:

- All luminaires specified, in working order;
- Ducting and cable containment internally and externally;
- All fixings;
- Cable trays;
- Items of equipment exposed to the public view/ line of site;
- Power and control wiring;
- Lighting control items;
- Others as noted in the relevant sections

The Contractor shall make an allowance for amendment and resubmission to be made and ordering, fabrication or manufacture to commence in accordance to satisfy the Contract Program.

4.5 Electronic Submittal Procedures

All Contractors' submittals shall be transmitted in electronic (PDF) format. The intent of electronic submittals is to improve environmental impact and expedite the construction process by:

- Cost – reduced cost of paper, printing, time, and couriers;
- Time – reduced turn around and transfer time;
- Environmental – reduced use of paper, toner, and transport.

Refer to the main contract documents for further details and requirements.

4.6 Contractor's Drawing Definitions

4.6.1 Design Drawings

The contractor shall do a full detailed design drawing set including schematics/details at a scale of no less than 1:200 for review by the Principal.

4.6.2 Coordinated Workshop Drawings

Coordinated workshop drawings shall show the inter-relationship of two or more engineering services and their relationship to the structure and building fabric. The main features of coordinated working drawings shall be as follows:

- Plan layouts shall be to a scale of at least 1:50 and be accompanied by cross sections to a scale of at least 1:20 for all congested areas;
- The drawing shall make allowance for installation working space and space to facilitate commissioning and maintenance;
- The drawings shall be spatially co-ordinated and there shall be no physical clashes between the system components when installed, critical dimensions, datum levels and invert levels shall be provided;
- The spaces between pipe and duct runs shown on the drawing shall make allowance for the service at its widest point. Insulation, standard fitting dimensions and joint widths shall therefore have been allowed for on the drawing;
- The drawing shall indicate positions of main fixing points and supports where they have significance to the structural design or spatial constraints;
- The drawings shall show the inter-relationship of the lighting, mounting arrangement, reticulation and building elements.

4.6.3 Installation Drawing

This is defined as a drawing based on the detailed design drawing or coordinated workshop drawing with the primary purpose of defining that information needed by the tradesmen on site to install the works.

The main features of installation drawings shall be as per co-ordinated workshop drawings plus:

- Allowances shall be made for inclusion of all supports and fixings necessary to install the works;
- The drawing shall make allowances for installation details provided from manufacturers' drawings;
- Allowances shall be made for structural supports and control equipment. This includes any alternatives to the designer's original specified option that have been chosen;
- Allowances should be made for the required reticulation;
- Ensuring that the required test points are incorporated to allow satisfactory testing, regulating, and commissioning.

4.6.4 Manufacturer's Drawing

This is defined as a drawing prepared by a manufacturer, fabricator, or supplier for a particular project, and which is unique to that project.

Examples include drawings for luminaire lengths, luminaire installation and mounting accessories, control and switchgear panels and associated wiring.

4.6.5 Builders' Work Information

This is defined as a drawing to show the provisions required to accommodate the engineering services which significantly affect the design of the building structure, fabric, and external works. Also, drawings (or schedules) of work to be carried out by building trade and are required to be costed at the design stage, such as penetrations.

The critical criterion with builders' work information is that it includes all openings (or other provisions) which significantly affect structure, fabric, or external works. Builders' work details Drawing to show requirements for building works necessary to facilitate the installation of the engineering services.

Builders' work details carry forward and confirm or refine structurally significant items from tile builders' work information, and also introduce new items that are not structurally significant, such as plinth dimensions for the actual plant items ordered.

Drawings must include luminaire fixings, penetration details and reticulation details.

4.6.6 Works as Executed Drawings

This is defined as a drawing showing the building and services installations as installed at the date of practical completion. The main features of the 'Works As Executed Drawing' shall be as follows:

- The drawings shall be to a scale not less than that of the installation drawings;
- Locations of all the lighting, remote control gear, switches, sensors;
 - All luminaire installed details;
 - All luminaire aiming angles as set in commissioning;

- The drawing shall be labelled with appropriate luminaires names and circuit/control groups;
- The drawings shall have marked on them positions of access points for operating and maintenance purposes;
- The drawings shall not be dimensioned unless the inclusion of a dimension is considered necessary for location.

4.7 Operating and Maintenance Manual

Prior to the production of the 'Operating and Maintenance manuals', the Contractor responsible for providing the drawings shall allow for adequate time on site to liaise with the Client to reach an agreed documentation standard.

The Contractor shall submit to the Principal prior to Completion Operating and Maintenance Instruction Manuals which shall comprise a description of each installation, its operation and the regular operating and maintenance routines to be adopted.

Electronic versions of Operating Instruction Manuals shall be provided, adequately sectioned, and annotated into volumes and referenced.

Refer to the electrical specification for any additional requirements.

The Content of O&M Manuals;

- The purpose of the installation;
- Installation records;
- Description of the installation;
- How the installation is to be used;
- How to keep the installation operational;
- Maintenance schedules;
- How the installation may be changed;
- Disposal of the installation.

The following sections set out a presentational sequence for an O&M manual describing what is required under each heading.

Contractual and Legal Guides:

The contractual and legal records of an installation shall include:

- The name and address of the installation;
- Details of local and public authority consents;
- Details of the design teams, consultants, installation contractors and associated sub-contractors;
- Dates for the start of the installation, for handover (practical completion) and for the expiry of the defect's liability period;
- Information on all guarantees affecting components, systems, and plant items, together with expiry dates and names, addresses and telephone numbers of relevant contacts.

For each item of equipment/ luminaire type installed and contained in the list of services covered by the O&M manual, copies of the following documents shall also be provided where applicable:

- Test certificates;
- Manufacturers' guarantees and warranties

A clear statement shall be made in this section concerning hazards and safety precautions of which the operators and maintainers need to be aware. This shall include;

- Any known feature or operational characteristic of the equipment or systems installed which may produce a hazard;
- Any known hazards against which protection can be provided;
- Any mandatory requirements relating to safety;
- Any other safety precautions which shall be observed;
- Any other relevant warning.

Overall Purpose

This section shall provide a general overview of the design intent and shall include a summary for each engineering system installed, giving;

- The parameters within which it has been designed;
- Electricity required to operate a system;
- The intended method of control.

This section shall be kept as brief as possible.

Description

This section shall provide a detailed description of each engineering system installed. It shall include:

- The system type;
- System location and what it serves;
- What the system depends upon in order to function;
- Design data, basic design parameters, basic assumptions made during design;
- Reasons for selecting particular equipment;
- Expected service life (where available);
- Planned operational efficiency.

Equipment Schedule

The type, model number and serial number of all component items within the system shall be listed, together with the names of their respective manufacturers or suppliers.

Parts Identification and Recommended Spares

This shall comprise a parts identification list detailing and identifying replaceable assemblies, sub-assemblies, and components. It shall include suppliers' recommendations for both spares and running spares (parts required for replacement due to wear or deterioration).

Items normally held in stock by a supplier, or for which a refurbishment service is available, shall be identified separately.

Spares Policy

This section shall offer a guide to the setting up of a spare's facility including recommended stock levels. It shall be prepared after consultation with the occupier regarding the consequences of failure, risk to core business, and the period of acceptable downtime. It shall also take into account suppliers' recommendations as given above. Again, those items normally held in stock by a supplier (or for which a refurbishment service is available) shall be clearly identified.

Commissioning Data

The results of all commissioning work and associated tests shall be given. This shall include all Light level and lighting control settings agreed upon and programmed as well as required electrical testing to the relevant codes and standards including:

- Measured data;
- Measurement points;
- Test equipment used;
- Details of calibration certificates;
- A statement of whether design requirements were achieved.

Operation

Instructions shall be given for the safe and efficient operation of the lighting system and associated electrical systems, under normal and emergency conditions. These will be in addition to manufacturers' literature for equipment items, and shall include:

- A recommended strategy for operation and control;
- An outline of the general operating mode;
- Standard operating and emergency operating procedures
- Precautions necessary to overcome known hazards;
- The means by which any potential hazards can be made safe;
- Target figures for both energy consumption and energy costs;
- Forms for recording running hours, energy consumption and energy costs.

Maintenance Instructions

The manufacturer's recommendations and instructions for maintenance shall be detailed for each luminaire including all mounting, and associated electrical items installed. The maintenance instructions are to include cleaning requirements to prevent corrosion and support the life of the installation and access requirements/strategy for future maintenance. Clear distinction shall be made between planned tasks (preventative maintenance) and work done on a corrective basis.

Maintenance Schedules

Maintenance schedules shall be provided for all preventive maintenance tasks. These shall be based on both manufacturers' recommendations and other authoritative sources (such as statutory or mandatory requirements). The schedules shall include:

- Inspections;
- Examinations;
- Tests;
- Adjustments;
- Cleaning including to prevent corrosion and extend life of installation;
- Calibration;
- Periodic overhaul.

The frequency of each task may be expressed as specific time intervals, running hours, or completed operations, as appropriate. Collectively, the schedules will form a complete maintenance cycle, repeated throughout the working life of the installation.

The source of the schedules shall be stated, and necessary periodic inspections and tests for instance, local authority or supply authority purposes shall also be noted.

Fault Finding

Procedures for the logical diagnosis and correction of faults shall be provided.

Names and Addresses of Manufacturers

Details of all manufacturers and suppliers of equipment listed in the manual shall be provided, including name, address, telephone number, e-mail contact and website. Any additional information likely to help the building operator make contact with, or obtain advice from, a manufacturer or supplier shall also be included.

Details shall be arranged in alphabetical order of manufacturer or supplier name to provide a logical information-retrieval procedure.

Index of Plans and Drawings

An index shall be provided of all 'Works As Executed Drawings' supplied during the installation process, identified by number and title. The index shall also include a schedule of all drawings issued by manufacturers and suppliers during the course of the installation work, such as control panel wiring diagrams.

Emergency Information

An important feature of any manual is the emergency information. This information shall be located at the end of the document for ease of reference, and shall include name, address, telephone and fax number, and e-mail addresses of the appropriate contacts in the event of fire, theft or burglary, and electricity failures.

Handover O&M Manuals

A complete set of all manufacturers' literature shall be provided for the equipment installed.

This literature shall provide the following information:

Manufacturers Literature

- Description of the product as purchased;
- The cost and date of purchase;
- Performance-behavioural characteristics of the equipment in use;
- Applications (suitability for use);
- Operation and maintenance details;
- Labour, plant, materials, and spatial resources required;
- Methods of operation and control;
- Cleaning and maintenance requirements;
- Protective measures;
- Labour safety and welfare associated with the equipment;
- Public safety considerations.

Where the data is not adequately provided in manufacturers' literature, the author of the O&M manual shall attempt to gather the information. If the information proves unavailable, or if a supplier is unwilling or unhelpful, this shall be treated as a breach of contract.

4.7.1 Training and User Guide

The Principal's nominated staff shall be fully instructed by the Contractor in the operation and maintenance of the installed services, and this shall commence with the commissioning of the lighting design and associated electrical services.

This instruction shall extend over the whole of the commissioning, running-in and maintenance periods and shall include "hands on" instruction to provide familiarity with the whole system. At the same time "classroom" type instruction shall be given to cover major components.

The instruction shall be carried out by specialist engineers to the satisfaction of the Principal. Provide all certificates necessary to occupy and operate the building.

Perform all necessary training to ensure satisfactory operation of the system by the users of the system.

The training shall take the form of two (2) days on-site with six nominated end-users of the system covering all aspects of the operation of the installed Lighting Control System and associated electrical elements.

At the completion of the project and after the completion of commissioning, the Contractor shall provide the client with a set of clear instructions and operational procedures of using and running the systems.

The Contractor shall:

- Arrange a meeting with the client and other stakeholders to present the systems, how they function and how the instruction and operational procedures will enable the client to occupy and operate the systems successfully and efficiently, including any trouble shooting procedures;
- After the meeting, conduct a tour of the site to all relevant areas to familiarise the client and other stakeholders of equipment/system locations and access routes for operation and maintenance;

- At the end of the Defects Liability Period, arrange a meeting with the occupants, client, and the Principal's Authorised Person to present how the systems have functioned, illustrate that all defects have been rectified and maintenance have been carried out;
- Provide a User Guide for the building occupant.

4.8 Preventative Maintenance

The contract works shall be maintained in a complete and satisfactory working order during the twelve (12) months following Contract Completion Date. The Contractor shall be responsible for the supply and cost of all parts and expendable items during this period.

The Contractor shall maintain the plant in accordance with the duties listed in the Operating and Maintenance Manual.

All fittings, mountings and fixings on the façade are to be regularly cleaned (in line with the manufacturer's recommendations) to prevent corrosion and extend the life of the installation.

4.8.1 Warranties

Refer to the main contract documents for the extent of the Defects Liability Period. In addition to the warranties required under the Defects Liability Period provide warranties on all services and systems, including installed reticulation systems, wiring systems and communication systems. Include the details of such warranties within the Operation and Maintenance Manual. All warranties shall include parts, labour, delivery, any re-testing and/or commissioning, removal, and disposal of faulty parts. All warranty periods shall commence on the date of handover, the Contractor shall make any necessary arrangements with equipment suppliers to ensure of this requirement is met.

4.8.2 Certification

Prior to Contract completion, the Contractor shall provide to the Principal's Authorised Person one copy of a file containing all Certification required under the Contract, including but not limited to:

All construction Certification provided by the Contractor's installers, including all support material as above;

- A covering certificate from the Contractor confirming the works comply with all relevant Codes, regulations, and requirements;
- The file of Certification shall commence with a detailed list of contents, followed by the Contractor's Certificate, and then followed by general Certification.

5.0 Electrical

5.1 Scope of Work

The scope of works shall include the supply, delivery, installation, commissioning, testing, certification, and warranty of the electrical services as specified and indicated on the drawings and specification.

The extent of work includes but not limited to the following:

- New 12 pole distribution board in an external IP54 enclosure where required
- Sub-circuiting cabling LSZH XLPE,
- Cable containment: Conduits, Flexible conduits, cable trays. Conduits and fittings installed externally shall be weatherproof and UV stabilised,
- New electrical pits to support the reticulation of submains from the existing switchboard to the new distribution board,
- Survey the existing cables, containment, and penetrations, and utilise existing containment, penetrations, and cables as much as possible,
- Investigation and nomination of possible existing conduit routes from existing Main Electrical board to nominated distribution board (new) for review and installation,
- Inspect condition of existing switchboards, submains and sub-circuit cabling and become familiar with site conditions,
- Contractor to provide on a monthly basis an update of Contractor's deliverables registers outlining information such as technical submittals, sample submissions, workshop drawings and Inspection and Hold points,
- Coordination with existing services and infrastructure,
- Disconnection, Demolition and Removal of existing redundant power and lighting services,
- Coordination with existing Hydraulic, Fire, Mechanical, Structural and Architectural Services on site,
- Earthing,
- PVC Minimisation,
- Provide work method statements with details on safety, power shutdown and decommission procedures,
- Supply and Installation of new electrical switchboards as detailed within the Documents and Drawings,
- Connection of new Copper XLPE submains from the existing switchboard to the new distribution board with cable termination at both ends and sub-circuit cabling to the new switchboard,
- Contractor to inspect the site, existing switchboard installation and also arrange new sub-circuit arrangements as necessary to ensure each sub-circuit load is compatible with the RCD protective device,
- Provision of temporary power supplies to existing loads during the any shutdown / down time on the existing switchboards,
- Provide new RCD protection for all lighting and power circuits as per current AS/NZS 3000 requirements,
- New labelling on new switchboards to match the Principal's agreed labelling strategy,

- Provide updated typed Circuit Schedules to be located within the new switchboard for all sections. Also provide a single 'excel' file with individual Tabs for each switchboard location,
- Cable Trays, Ladders, Conduits and Cable Containment for Electrical and Lighting works,
- Cables, wiring systems,
- Luminaires including lamps and control gear, mounting systems, and block outs,
- Lighting control system,
- External Lighting,
- Workshop Drawings,
- Samples,
- Mock-ups and hold points,
- Testing and Commissioning,
- As Built Manuals and Drawings,
- Operation/User Manuals,
- Training,
- Warranties,
- 12 months Defects liability,
- 12 months Preventative Maintenance.

All works, and equipment of a minor nature not specifically mentioned but necessary for the operation for the above-mentioned equipment and systems.

5.2 Aesthetics

The Contractor is responsible for the satisfying the Architect's requirements and the aesthetic quality. Ensure there are no exposed services visible from Front of House and Public Spaces line of sights. Provide services that minimise obtrusive equipment and services and provide elegant, concealed elements inclusive of all paint and special covers.

The aesthetic requirements for a neat, geometrically set out of the building services extends to the Back of House Areas and Plant Areas.

Services in plantrooms, cupboards, risers and in within the panels and equipment must be neatly and evenly fixed supported, laid out and reticulated in a geometrically manner. An attention to detail and uniform layout of systems and services is a requirement. Untidy and messy design and installation works will be defected.

All services within the ceiling voids must be painted to an agreed colour as advised by the architect. Where cable colours are such for statutory reasons then covers are to be provided to conceal them.

5.3 Existing Spare Breakers

Reference should be made to the several existing spare circuit breakers within the Main switchboard in Building ED within ED.G.03 electrical room. Contractor to inspect and confirm the condition of the spare breakers to be utilised for the new external distribution board (DB EX). Note it is necessary to trace spare conduits (if any) and test breakers as the extent of records is not ideal. Contractor is to provide

new switchboard schedules laminated and mounted within distribution board enclosure.

5.4 Proposed Lighting Sub-Circuiting

Power cabling installation to maintain a minimum of 50mm from all other services. Cabling to have relevant segregation to minimise impacts of electromagnetic interference with communications cabling where there are long parallel runs or 300mm separation between services.

Power cabling and conduits to have dedicated supports separate from other services. Cabling to maintain bend radii as per Standards and cable manufacturer requirements. Cabling to be protected from all sharp edges with grommets or folded metal edges. Cabling to have sufficient length to not be pulled tight against edges to avoid long term cable damage.

Circuiting of the lighting must fully comply with AS/NZS 3000:2018. Cabling sizing to account for voltage drop, earth loop impedance, protection from faults, and for 20% spare capacity.

The circuiting must also be arranged to suit the required switching and control proposal. Circuit Breakers must be 20amps 1phase. Provide all the control data cabling between the luminaires and drivers.

Lights must be wired from 20amp RCBOs Type A 30mA. Circuit Breakers complete with a minimum of 2.5mm sq Cu multi strand cable minimum with larger cables used for voltage drop where warranted. As required 4 or 6sq Cu multi strand cable or greater to be used on cable runs where necessary to avoid excessive voltage drop. i.e. →30m. Breakers are to ensure discrimination and protection and be sized with 20% spare capacity.

Generally, the intent is to make use of the existing breaker within the main switchboard. However, allowance for all new circuit breakers that support the new external distribution board is to be included for. A new 63A three phase 12 pole boards mounted externally adjacent the proposed temporary car park area is proposed.

The reuse of the existing services conduits (if any) is encouraged from a cost and environmental perspective. Where the existing services are being used, the Contractor must ensure compliance with the relevant standards and warrant the installation as part of the certification.

Provide new circuits to nominated locations from the new distribution board.

Contractor to circuit a maximum of 20 luminaires per circuit and ensure distances are less than 10 meters from the luminaire to the driver. Contractor to confirm if circuiting is possible across the drivers. Contractor to coordinate circuiting with luminaire switching.

Balance the Load

Ensure that the loads are balanced across the three (3) phases at the new Distribution Board. Rearrange the circuits to obtain a balanced 3-phase load. In some cases, this

may involve amendments to existing circuits. The currents across the phases should be within 20% on EDBs.

Circuit Schedules

Provide type schedules indicating all CB sizes and details of the loads on the final sub-circuits for local boards down-stream where line conditioners are removed. Locate in purpose made metal framed schedule holder mounted within the switchboard, with clear plastic cover. Provide an electronic copy in EXCEL format.

Layout Drawings

Provide an A3 laminated Power and Lighting Layout plans fixed to the wall or doors. Provide the plans in Electronic Format as part of the As Built documentation.

Thermographic Surveys

Provide thermographic survey of the Switchboards prior to and upon completion of all switchboard work. Carry out surveys and submit the results in colour A4 electronic format.

RCDs

Provide RCDs to all light and power circuits. Type A 30mA RCBOs.

Conductor Colours

For fixed wiring, use coloured conductor insulation. If this is not practicable, use heat shrink at least 150mm length on to each conductor at the termination points.

Active conductors in single-phase circuits: Red.

Active conductors in polyphase circuits:

- A phase: Red;
- B phase: White;
- C phase: Blue.

5.5 Cabling and Containment

Contractor to ensure all cabling and containment installation is concealed from public view and installed neatly. Contractor to confirm all proposed penetrations with structure, architecture, heritage, and any fire sealing requirements prior to any works on site.

The reuse of the existing services containment is encouraged from a cost and environmental perspective. Where the existing services are being used, the Contractor must ensure compliance with the relevant standards, deem containment is in good condition and warrant the installation as part of the certification.

All external conduits are to be weatherproof sealed, and UV stabilised. PVC is to be avoided. HDPE or metal conduits are proposed. Finishes to be allowed and approved by architecture and Principal.

5.6 Penetrations

Do not penetrate structural members without approval from the Superintendent. The services above ceiling spaces should be arranged to minimise the number of penetrations through fire compartment walls. The Contractor must seal all penetrations to maintain the fire and acoustic rating properties of the wall, floor, or slab.

Do not penetrate damp proof membrane.

In floor slabs run conduits entering a building at ground level under the waterproof membrane and vertically penetrate the membrane and the floor slab. In roofs provide a suitable seal between the conduit and the roofing material via over-flashing or deck tight system.

Obtain approval for every penetration through existing building structures. Fit a sleeve for each penetration through ground floor slabs, ground floor beams and external walls for cables not enclosed in conduit. In addition, for MIMS cables fit a sleeve for each masonry penetration.

Provide a penetration of a diameter 10mm greater than the conduit or sleeve diameter for conduits and sleeves penetrating existing external walls, ground slab, or ground floor beams.

Seal penetrations around conduits and sleeves with a material or product sufficient to provide the necessary fire and acoustic rating properties.

Fire Barriers

All Standby power cables that pass through a fire compartment or pass from one fire compartment into another must be fire rated polymeric or MIMS cables. All fire compartments walls are indicated on the drawings.

Handling Cables

Report damage to cable insulation, serving or sheathing.

Straight-through Joints

Unless unavoidable due to length or difficult installation conditions, run cables without intermediate straight-through joints.

Cable Joints

Where permitted, locate in accessible positions in junction boxes.

Extra-low Voltage Circuits

Individual wiring of extra-low voltage circuits: Tie together at regular intervals.

6.0 Lighting - General

6.1 Lighting Intent

A key objective of the lighting (and associated electrical works) as detailed in this specification is to enhance the car-park presence and identity for the night-time experience by providing a safe environment for pedestrian and vehicular traffic and recognising the need for specific guidelines, environmental considerations, and visual comfort.

The existing light pole and floodlights mounted to this pole are to be disconnected and removed. The new lighting design will consist of 12-metre-high poles and optic-controlled luminaires, with a warm-white colour temperature. This solution ensures compliance with the required illuminance levels and uniformity of AS/NZS 1158.3.1:2020 and AS/NZS 4282. The design will utilise an intelligent, adaptive lighting controls (refer below) that can minimise energy consumption, extend the life cycle of the luminaires, and reduce the obtrusive effects of outdoor lighting.

6.2 General

Supply and install all luminaires and lighting controls as indicated on the drawings and as specified. All luminaires are listed on the legend / luminaire data sheets must be installed complete with lamps, control gear and accessories necessary for their proper functioning and must be in accordance with the provisions specified herein

All luminaires are to be easily accessible for maintenance within the need for special access equipment.

All external junction boxes required for the installation are to be IP68 gel-filled.

Unless noted otherwise, all finishes are to be matt (no gloss or sheen).

Where required, the Contractor will be required to adjust the design of the lighting and lighting control system as outlined in this specification and as indicated on the drawings, to suit the site conditions as necessary.

Specific manufacturers or trade names or figure numbers mentioned in the Luminaire Data Sheets are for the purpose of defining the required lighting/ photometric performance, class of materials, form, quality, design, and workmanship.

The following selection criteria inform the luminaire selection:

- Performance (photometrics, Light output ratio/ luminaire efficiency, operating temperatures and heat management, size uniformity of luminous surfaces and openings, glare ratings);
- Quality (workmanship, quality of manufacture and components, Ingress protection ratings, class of material);
- Compliance with the relevant standards (evidence/ certificate to be provided);

- Architectural quality and aesthetics (including shape, dimensions, and finish);
- Track records of lighting/ luminaire companies.

The Contractor must be responsible for the specified performance of the equipment and materials and of the installations of which they form part. The Contractor should therefore obtain from such manufacturers or suppliers adequate guarantees in respect of such equipment and materials and ensure that the supplied lamps and control gear are compatible.

At the commencement of the project the Electrical Contractor must notify the design team of the lead times of the fittings and must confirm the lead times prior to placing an order. The Electrical Contractor is responsible for ensuring the delivery schedules meet the program requirements.

6.3 Workshop Drawings

Refer to Section 4 for complete workshop drawing requirements.

Specifically, the following workshop drawings must be submitted and approved:

- All luminaire mounting details, poles, brackets, and fixings;
- All penetration sealing details;
- Lighting control system;
- Lighting control interface.

6.4 Equipment Selection

Refer to 247150 - SPEC L02 - Luminaire & Electrical Equipment Datasheets [A] for all luminaires, accessories, and specific requirements.

The equipment selections have been made to:

- Align with the overall lighting intent (as described above)
- Align with requirements and project aspirations, including aesthetic and functional needs
- Consider daytime impact
- Provide controllability

All final equipment, mounting and fixing elements must be selected and arranged to minimise corrosion and impact of the external weather conditions. Where metals are used these are to be the same material or in the same galvanic series. If otherwise, metals to be separated to prevent galvanic corrosion.

6.5 Spares and Contingency

A number of additional luminaires and accessories shall be supplied to the client for future requirements. The following spare parts shall be provided as part of the works:

- Provide 5% additional spare lenses, DALI control gears, daylight sensors and PIR sensors.

6.6 Light Sources (LED)

Approved LED manufacturers are as follows: Cree, Philips (Lumileds), Nichia, Osram, GE, Xicato or as specifically specified in the Luminaire datasheets.

If other manufacturers are suggested by the contractor, written acceptance must be obtained from the Superintendent.

The LEDs are

- To be supplied with suitable control gear to match the load;
- Colour consistency to be checked and confirmed prior to installation;
- LED components to be binned for flux, colour (in wavelength) and forward voltage (Vf).
 - Manufacturer to provide confirmation of Binning for future lamp replacements.
 - The binning coordinates should be contained within a 3-step Mac Adam ellipse.
- The rated lamp life should be a minimum of 50,000 hours operation with 80% lumen maintenance;
- Contractor to provide the following confirmation from the LED luminaire supplier/ manufacturer as per of the O&M manuals:
 - Confirmation of how colour consistency is ensured among fixtures and test data demonstrating colour stability over time to be provided;
 - Confirmation that the thermal management system keeps the LED junction temperature below specified maximums;
 - Written binning policy;
 - Written end-of-life policy, and how spares will be made available;
 - Length of warranty, and details of what exactly is covered (details of which components are included and if labour is included);
 - Details of LED manufacturer.

6.7 Control Gear

LED Control Gear shall be capable of following:

- Be compatible with the existing control system that is it integrated into;
- Digital Controlled Dimming with a dimming curve equal to Tridonic or Dynalite;
- Switching operation should only be via digital signal;
- Constant light output independent of fluctuating supply voltage between 198V-254V;
- Have polarity free control bus;
- must meet IEC harmonic standards;
- Power factor greater than $\rightarrow 0.95$;
- High Frequency Operation: operating frequency 40-100 kHz;
- Intelligent Voltage Guard;
- Intelligent Temperature Guard;
- DALI/ DMX Compatible and programmable/ addressable via the digital control bus;
- Error feedback and Programmable features in DALI/ DMX Mode;
- Ta of $\rightarrow 50$ Degrees C;
- Energy class CELMA A-1 Energy Efficiency Index (EEI);

- ENEC and CE identification and Certified to:
 - EN 55015,
 - EN 55022,
 - EN 61347-2-4,
 - EN 60925,
 - EN 61347-2-3,
 - EN 60929 8.1.
- must meet IEC harmonic standard EN 61000-3-2;
- ASIC light management.
- Fully electronic lamp management and digital communication with ASIC (Application Specific Integrated Circuit) and microprocessor.
- Safe shutdown of defective lamps;
- Automatic restart after lamp replacement;
- thermally protected and in compliance with IEC specifications 928 and 929 for safety and performance.

- LED drivers are required to provide flicker-free dimming; therefore, are nominated to be provided from an approved list of manufacturers who have provided evidence of meeting the flicker free outcome.

These include:

- EldoLED
- Philips
- Tridonic

If other manufacturers are suggested by the contractor or supplier, evidence is to be provided confirming flicker free lighting is provided.

All DALI control gear is to be compatible. Care has to be taken to not combine DALI and DALI-2 gear and to ensure all luminaires, control gear and systems are compatible and operate as per control intent.

6.8 Installation of Luminaires

The luminaire and associated equipment installation must be conducted in accordance with the luminaire manufacturers' instructions and recommendations.

The installation of the lighting must include a number of Hold Points prior to final order of fittings. Samples of the proposed fittings must be submitted for inspection. The lead time of such fittings needs to be considered in this exercise.

Generally, the orientation, heights, aiming and exact location with regard to details must be confirmed prior to installation.

The fittings must be positioned in line and set out according to the lighting consultant's and civil documentation.

Luminaires must be arranged to suit the desired lighting effect and be positioned in accordance with manufacturers' recommendations.

Where painted surfaces are damaged, or building fabric is breached or damaged in any way, they must be made good. Such repairs must be of the same standard as the original paintwork subject to approval.

All luminaires must be effectively earthed.

Luminaires must not be used for illumination during construction. Internal low brightness luminaires must be sealed with plastic wrapping to prevent dust entering the fitting which must be removed as directed by the Subcontractor prior to Completion.

6.9 Location

The exact location of the lighting must be finalised by the Contractor. The indicative positions have been indicated on the Lighting Details and Layout Drawings. The final positions must be agreed in the workshop drawings and must take into account coordination of services and specific AS/NZ Standards.

The lighting detailed to date must be included as part of the contract works and minor alterations must be forthcoming. The final location of luminaires is subject to change and allowances in the tender must be made for such minor alterations.

Any modifications and deviations to equipment and services from those shown on the drawings must be made where necessary to accommodate the services within the actual space conditions with approval from the Principal and lighting designer.

All equipment which must be serviced, operated, or maintained must be located in fully concealed and accessible positions. Access doors must be furnished as required for this purpose. If any equipment cannot be so located the same must be brought to the attention of the Superintendent. Locations are to be coordinated with heritage architect and with consideration given to manufacturers recommendations.

The Contractor will at all times be fully responsible for the correct positioning, leveling, and installation of all work and equipment installed by them in accordance with the specification and in consultation and co-operation with all other trades. No extra costs of any kind will be allowed if work and equipment have to be removed and replaced.

6.10 Supports

Mount luminaires on proprietary supports by means of battens, trims, noggings, roses, packing material, structural supports, and outreach arms, as necessary.

All screws, battens, brackets, roses, noggings, trims, packing etc., necessary for the proper fixing of luminaires, must be provided by the subcontractor as part of the works, whether individually specified or not. All elements must be suitable for external use and the corrosive harbour environment. All aluminium to be powdercoated to match the façade or anodised to prevent corrosion. Where two metals are in close proximity to each other, materials to be the same or in the same galvanic series. If otherwise they must be suitably separated to prevent galvanic corrosion.

Packing pieces must be fitted where required to level the luminaires and to prevent distortion. Where integrated into the ceiling structure, all required fixing and integration items are to be co-ordinated and provided for.

Where a building member does not exist in the position required, the Subcontractor must supply and install a suitable fixing. Metal sections provided in suspended ceilings must not be smaller than the main framing of the suspended ceiling.

Adjust the length of suspensions so that the lighting system is level and even.
Tolerance: ≤ 3 mm.

Levelling: The suspension system length must be adjusted so that the lighting system is level and even.

Where required, fit packing pieces to level luminaires and prevent distortion of luminaire bodies.

6.11 Samples

Samples of **all** luminaries specified, the proposed equipment and installation must be submitted for approval prior to commencement of manufacture or the placement of orders.

The samples must be in working condition and equipped with all light sources and control gear as specified and necessary for their proper functioning.

Also provide technical detail and literature as required and detailed throughout the specification.

The samples should be submitted in a timely manner.

At the commencement of the project the Electrical Contractor must notify the design team of the lead times of the fittings and must confirm the lead times prior to placing an order. The Electrical Contractor is responsible for ensuring the delivery schedules meet the program requirements.

Make allowance for amendment and resubmission to be made and ordering, fabrication or manufacture to commence in accordance to satisfy the Contract Program.

It is noted that all equipment when required to be white or black must be matte (unless specified otherwise).

6.12 Alternatives

The luminaries and associated equipment stated in the luminaire schedules shall be allowed for by the Electrical Contractor in the tender price.

Indicative custom mounting brackets and location mock-ups are to be allowed for by the contractor in the tender price.

Any alternative offers of equipment can be offered as a pricing option only; however, the price should not be based on alternatives. Alternatives should be

provided with the price variation that would result and details of differences to the specified fitting.

If alternatives are submitted, the equipment shall be as specified or approved equal in every aspect. It is Contractor's responsibility to provide well documented evidence comparing the alternatives with that specified to substantiate the equality of the alternative. The basis of the luminaire specification (selection criteria as noted in the luminaire data sheets) shall also form the base for the selection of alternative fittings.

It is the Contractor's duty to ensure that any luminaire or electrical equipment submitted as an alternative to a specified item meets the same standards as the specified item, achieves the same results and has the same standard of review by members of the design team:

- Alternative equipment must be considered both individually and in relation to other items on the project to ensure aesthetic acceptability.
- The basis of the luminaire specification (selection criteria as noted in the data sheets) must also form the base for the selection of alternative fittings;
- The submission of full photometric characteristics for all alternative luminaires being offered must be ensured, including the necessary polar curves or equivalent as well as detailed lighting calculations;
- The equipment being offered as alternatives must be of equal quality, durability, and robustness as the specified items;
- Alternative fittings need to be assessed by the same parties that are involved in the approval of specified luminaires;
- Samples for both specified and suggested alternative luminaires and any components forming the total luminaire and its support must be submitted for approval prior to commencement of manufacture or the placement of orders;
- The energy consumption of the submitted luminaire must be checked against that of the specified luminaire; Building Act 2004 Part H1 calculations must be performed should the energy consumption/ luminaire efficiency differ.
- The ease and simplicity of maintenance should be considered as part of any assessment of any alternative submitted;
- Any alternative luminaires should meet any specific maintenance factor for the installation;
- The adjustments, if any, that would be affected to the tender price if the alternative were approved;
- For any alternatives submitted, it is the Contractor's responsibility to ensure that the power requirements satisfy the maximum demand, the fitting dimensions match the details and construction process, and the lead time matches the overall procurement strategy;
- The Electrical Contractor is responsible for ensuring the delivery schedules meet the program requirements.

The Contractor must not order or install alternative equipment and materials prior to the Superintendent's written authority.

6.13 Hold Points/ Tests

There are a number of hold points and witness points prior and during the construction phase of the project which require inspection and verification. The Contractor shall provide sufficient notice (at least 2 weeks) to all relevant parties to attend inspections or for the review of submission. Works shall not proceed without relevant authorisation. Refer to the relevant sections of this specification for details on submission, inspections/witness, testing and commissioning.

Hold Points Include:

- Sample review
- Submission and Review of Workshop Drawings;
- Submission and Review of Technical Data;
- Inspection and Review of Installation works as detailed below:
 - Authority approvals to proceed with works have been obtained;
 - Work Method Statements for specific works considered sensitive or works that may have an impact on the functional operation of the facility or adjacent facilities;
 - Prior building penetrations;
 - Inspection before removal of scaffolding or when certain areas are not to be accessible and more for other reasons;
 - Commissioning, Calibration, Testing and Certification of all systems prior to Completion and Occupation.

The above is not intended to be exhaustive but to emphasise the sequence in which these key items should take place to avoid instances such as equipment being ordered prior to review thus leading to deviations from specification or coordination problems due to change in dimensions.

7.0 Lighting Control

7.1 Operation

All lighting is to be controlled via a new intelligent lighting control system, which is to be operational across all luminaires. All luminaires will dimmable via DALI. The final system specification is to be finalised by the Contractor with the manufacturer and supplier of the luminaires, and the Principal and lighting designer.

Each luminaire is to be controlled automatically via a time clock, with additional override of the PE cell and PIR sensor. The dimming/ intensity level for each luminaire is to be set during commissioning. Master on/off control is also to be provided at the main electrical board to allow the automated lighting settings to be over-ridden if required.

All dimming transitions including turning on/off of the lighting are to have a smooth fade rate.

Generally, the lighting is to be programmed to operate in the following modes:

Sunset-11pm:

Subcategory PC2

- Night-time vehicle and/or pedestrian movements – **Medium**
- Fear of Crime - **Medium**
- Lighting to be Triggered on when daylight levels are low by PE cell (or if not triggered at time of sunset, triggered on via timer).

11pm-1am:

Subcategory PC3

- Night-time vehicle and/or pedestrian movements – **Low**
- Fear of crime – **Low**
- Lighting to dime down to PC3 levels, triggered on via timer.
- If movement is detected by a PIR sensor, the lighting will ramp back up (over 3 seconds) to PC2 levels for a period of 15 minutes, after which, if no further movement is detected, they will dim back down to PC3 levels.

1am-Sunrise:

Lighting to turn off

- Lighting to turn off, triggered on via timer.
- During this period the carpark would be considered closed and Steensen Varming recommends switching the lights off, as this signals the car park is not intended for use.
- If movement is detected by a sensor, the lighting will ramp back up to PC3 levels (over 3 seconds) for a period of 15 minutes, after which, if no further movement is detected, they will turn off.

All final settings to be set and forget. They are to be finalised during commissioning.

7.2 Circuiting

Circuiting of the lighting must fully comply with AS/NZS 3000 and have 25% spare capacity. The circuiting must also be arranged to suit the required switching and control proposal. Refer to the electrical drawings and specification for circuiting arrangements.

7.3 Light Switches

Light switches must be of a suitable manufacture and rating and be in compliance with AS 3133.

Unless otherwise indicated, light switches must be of the flush type, fixed in wall boxes to suit the installation.

Also provide labelling on the light switches where the operation of the switch is not apparent.

7.4 Labelling of Lighting Controls

Provide concealed labels on each lighting control device indicating the relevant lighting circuit. The hidden labels must be behind switch face plates.

7.5 Dimmers, Relays, and Controls

The Contractor must supply and install dimmers, dimmer controls, relays, relay controls, and time clocks as necessary to complete the installation. Any control infrastructure made redundant by the works is to be removed/ terminated. as indicated on the drawings and as specified. Each dimmer must be selected and sized to suit its lighting load and application. The Contractor must submit with details of the proposed dimmer and a working sample for demonstration and approval prior to ordering.

The system must be fully compatible with all the dimmable electronic ballasts and electronic transformers incorporated within the luminaires nominated.

8.0 Lighting Commissioning

The Review, Testing and Commissioning process must ensure that the design intent is realised in the final installation.

All testing and commissioning must be carried out to conform to this specification as well as the following:

- BSRIA Commissioning Guides;
- CIBSE Commissioning Codes covering;
- Manufacturers Recommendations;
- Standards, Regulatory and Authority Requirements.

The Contractor must be fully conversant with the requirements of these codes and apply them to this activity. The Contractor must allow full co-operation and provide a service online with the requirements of this section to complement this role.

The commissioning process must pass through a number of stages in parallel with the construction of the building and the procurement and installation of equipment. These stages in summary must include planning, coordination of many different suppliers, manufacturers and installers, preparation of documentation, on and off-site testing, pre-commissioning, commissioning, providing training, post-handover re-certification checks and post-handover maintenance and defects attention.

The Contractor shall submit a written document showing the tests to be carried out prior to the commencement of commissioning for approval by the consultant and the client. Following commissioning, documented proof of the success of the tests shall be submitted for acceptance.

- Before the arrival of the client representative's inspection, the Contractor shall perform the test and adjustment as detailed below, as well as any other commissioning and testing
- The Contractor shall furnish all test equipment as required to perform these tests and perform all work required to arrive at the performance specifications required in this document.
- The Contractor shall prepare and submit to the client's representative a work method statement for the testing and commissioning procedures and indicate on these sheets all results and note of corrective measures taken in the event of any technical problems encountered during the commissioning.
- The test results should be submitted to the consultant at least 2 days before the scheduled inspection.
- Failure to pass these tests completely will result in the non-certification of completion.
- The Contractor will have to bear the client's representative charge rate for another scheduled inspection.
- No test will be carried out without the declared test instruments.
- The practical completion shall be defined through a full day (or as required) demonstration to the client and its advisers the functionality.
- Failure to demonstrate the above will deem a non-completion.
- On a case-by-case basis, if there is an equipment fault out of the Contractor's control, practical completion may still be issued if the defects

out of the test and demonstration shall be minor enough not to render the system inoperable for its main intended purpose.

All necessary labour, manufacturers'/ suppliers' representatives, instruments, manufacturer's literature, and fuel must be made available by the Contractor. Record manufacturer's name and model number of each instrument used in all tests and last date of calibration.

All test data will be tabulated with design requirements. All test data must be signed and dated by the Contractor's representative, with details of their official position.

8.1 Pre-commissioning

All final settings must be agreed at commissioning stage.

All luminaire positioning that requires co-operation with other installers should be coordinated well before commissioning stage.

All lighting and associated electrical system components should be installed according to the lighting and electrical drawings and specifications; all components should be those specified in the original design.

All control gear must be checked for compliance with the associated light sources.

Luminaires should be in the correct position (as defined by drawings) and in the correct orientation. The spacing between the fittings must be as shown in drawings. Critical offset distances of luminaires or structures must be achieved according to architectural and lighting documentation.

Alignment of all luminaires should be checked and ensured.

All luminaires must be clean and undamaged with the correct light sources fitted. All safety accessories on luminaires should be securely mounted; associated remote control gear should be fixed securely and concealed in a secure position.

The operation of all luminaries must be verified, and faulty equipment must be replaced.

The grouping of the luminaires must be as described on the drawings and in this specification.

All light sources must have the correct colour temperature as specified.

The installation of all luminaires must be carried out in accordance with the light source and luminaire manufacturers' installation instructions and manuals.

All items must be uniquely and clearly labelled.

8.2 System testing

The Contractor shall install, configure, and test all systems.

A proposed list of tasks to be undertaken by the Contractor are:

- Test all cabling infrastructure, linking equipment and systems to confirm they achieve required performance
- Conduct tests to confirm each piece of equipment is functioning correctly
- Test interoperability between all components forming each system identified within this document
- Perform system functionality testing including software interfacing and control of all sub-system components and equipment as required
- All tests to AS/NZ3000 and its referenced standards
- Test lighting control systems to ensure it is functioning correctly
- Test and provide all results for Lighting and power circuits.

8.3 Commissioning

The exact details of any proposed Testing and Commissioning must be confirmed and agreed prior to arranging the time and date.

The operation of all the aspects of the lighting system must be demonstrated.

It is important that the aiming and focusing of directional/ adjustable luminaires (or luminaires with adjustable shield) and wall washers are adequately addressed. If other lighting needs to be switched off during the process, the site should be allowed to be free from other works requiring light.

The commissioning steps should be carried out as follows:

- The control system should work and be programmed correctly (as per documentation);
- It should be ensured that the user interface functions correctly and the correct groups of luminaires/ scenes;
- The luminaires should not dim to a point where flicker is detected. Appropriate time-delays must be set to reduce nuisance dimming caused by transient conditions;
- All default control settings should be correct and according to the lighting designer's intent.
- In the user interface, all fittings, groups, and scenes are to be specifically named to ensure ease of controls for future adjustments
- All sensors must be located in a representative location. They must be calibrated to give the specified light levels at the specified positions. The calibration should be performed using a certified, calibrated portable light meter.

Calibration of the light sensors should take place at completion of the installation. When local calibration cannot be avoided, any adverse effects by the person commissioning must be avoided (e.g. by the use of remote-head light meters).

The Contractor must engage specialist certified personnel to complete the detailed commissioning and programming of the lighting control systems to suit the various scenes and functions required. Details of the scenes and functions are provided in

this specification. The lighting control system functionality and various programmed scenes must be reviewed by a Lighting Consultant representative.

Final details of the scenes and functions must be confirmed by way of workshop drawings and on-site meetings.

It is envisaged that this exercise will involve at least 1 site meeting (after daylight hours) to ensure the intent of the lighting design is met. Thus, reprogramming of the system to suit will occur.

The operation of all luminaries must be verified, and faulty equipment must be replaced at no additional cost.

The Contractor must allow to liaise with the dimming system supplier in order to ensure that default scenes and pre-sets as specified and required are programmed into the dimming system at practical completion. The dimming system supplier must provide commissioning staff to facilitate the final programming of the dimming system during the commissioning phase. Costs and charges associated with programming of the dimming system and engagement of the dimming system manufacturer's commissioning staff must be borne by the Contractor and must be included as part of the supply and installation of the dimming and control system. The Contractor should allow for some or all commissioning sessions to be conducted outside normal working hours.

The Electrical Contractor must allow for some of or all commissioning sessions to be carried outside normal working hours in order to capsule nighttime settings etc.

The Electrical Contractor must allow a programming period of 1 day to revisit the system and make minor adjustments.

8.4 Final Checks

The lighting system should be checked for correct operation under representative operational conditions following completion of the installation. Contractor to allow for minor adjustments to the control settings to be undertaken with the client.

The Contractor must provide 'As Built' Documentation in accordance with the Specification including results of the testing and commissioning for review by the Lighting Designer and relevant stakeholders.

Prior to the issue of the 'Final Certificate' the performance of all safety and control functions of each system must be verified by way of certified report from the respective manufacturers or suppliers. Such checks must be undertaken regularly and not later than one (1) month before the schedule expiry date of the Defects Liability Period.

When I'm working on a problem,
I never think about beauty. I think
only how to solve the problem. But
when I have finished, if the solution
is not beautiful, I know it is wrong.
Richard Buckminster Fuller

Mechanical Engineering
Lighting Design
Sustainable Design
Electrical Engineering

e : info@steensenvarming.com

ELECTRICAL AND LIGHTING SERVICES

STEENSEN VARMING

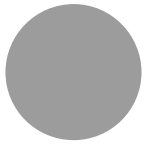

Western Sydney University Temporary Carpark Luminaire & Electrical Equipment Datasheets



When I'm working on a problem,
I never think about beauty. I think
only how to solve the problem. But
when I have finished, if the solution
is not beautiful, I know it is wrong.
Richard Buckminster Fuller

Mechanical Engineering
Lighting Design
Sustainable Design
Electrical Engineering

e : info@steensenvarming.com

STEENSEN VARMING

Document Revision and Status

Date	Rev	Issue	Notes	Checked	Approved
04.10.2024	A	For Tender		SS/IM	SS
27.06.2025	B	For Tender	All changes indicated in red	SS/IM	SS

Sydney June 27th, 2024

Ref. No. 247150 – SPEC L02

Matthew Saunders

Lighting Designer

matthew.saunders@steensenvarming.com
+61 02 9967 2200

Manoj Matthew

Senior Electrical Engineer

manoj.matthew@steensenvarming.com
+61 02 9967 2200

Simm Steel

Associate

simm.steel@steensenvarming.com
+61 02 9967 2200

Disclaimers and Caveats:

Copyright © 2025, by Steensen Varming Pty Ltd.

All rights reserved. No part of this report may be reproduced or distributed in any form or by any means, or stored in a database or retrieval system, without the prior written permission of Steensen Varming Pty Ltd.

This document is confidential and contains privileged information regarding existing and proposed services for the Building. The information contained in the documents is not to be given to or discussed with anyone other than those persons who are privileged to view the information. Privacy protection control systems designed to ensure the highest security standards and confidentiality are to be implemented. You should only re-transmit, distribute, or commercialise the material if you are authorised to do so.

1.0 Luminaire Datasheets

Type and Manufacture

The luminaires in these data sheets intend to indicate a preference for a particular make and model which have been specifically selected as they incorporate features required in the design including materials, shape, output and quality.

The following selection criteria inform the luminaire selection:

- Performance (photometrics, Light output ratio/ luminaire efficiency, operating temperatures and heat management, size uniformity of luminous surfaces and openings, glare ratings)
- Quality (workmanship, quality of manufacture and components, Ingress protection ratings, class of material)
- Compliance with the relevant standards (evidence/ certificate to be provided)
- Architectural quality and aesthetics (including shape, dimensions and finish)
- Track records of lighting/ luminaire companies

Specific manufacturers or trade names or figure numbers mentioned in this document are for the purpose of defining the required lighting/ photometric performance, class of materials, quality, design or workmanship

Any lighting equipment shall be as specified or approved equal in every aspect. If alternatives are submitted, well documented evidence has to be provided comparing the alternatives with that specified to substantiate the equality of the alternative. The basis of the luminaire specification (selection criteria as above) shall also form the base for the selection of alternative fittings. Alternative fittings need to be assessed by the same parties that are involved in the approval of specified luminaires including the lighting designer, the architect, the client or client representative and the superintendent. The assessment includes a sample review process.

For any alternatives submitted, it is the contractor's responsibility to ensure that the power requirements satisfy the maximum demand, the fitting dimensions match the details and construction process, and the lead time matches the overall procurement strategy.

Notes

- All luminaires to be supplied with a warranty of minimum 5 years. For LED luminaires warranty to include colour consistency within 2/3 MacAdam steps.
- All LED luminaires need to be provided with binning range information, life expectancy (LM80) information and confirmation regarding heat management.
- A number of spare parts (such as diffusers) shall be provided, nominally 5% **additional spare lenses, DALI control gears, daylight sensors and PIR sensors.**
- All control gears and controllers to match the relevant light sources and power ratings and to comply with the control system specified.

P1

Description	12-metre-high pole with optic-controlled luminaire (single head)
Model	Luminaire: Schreder IZYLUM EVO 3 Pole: GM Poles Tapered Poles – BK Range
Catalogue No.	Luminaire: IZYLUM EVO 3 5304 40 LEDs @ 400mA WW 730 230V 02-58-001 Glare limiter Pole: TP-BK12 – (TBC by supplier)
Manufacturer	Schreder GM Poles
Supplier	Sylvania Schreder GM Poles
Light Source	LED, 3000K, CRI 70+, 5304 40 LEDs, 49.5W, 6200-7000lm, 400mA L95 100,000 hours (TA <= 25°C) ULOR 0%, ULR 0%
Finish	Luminaire: Polyester powder coated aluminium in RAL 7040 window grey finish, PMMA optic and tempered glass Pole: Standard high quality hot dip galvanised with additional dual coat powdercoat in grey, to match RAL 7040 finish of luminaire or closest standard finish available. Contractor to allow for alternative black finish to pole and luminaire, or custom colour, if requested by the client.
Dimensions	Luminaire: 737 mm x 97 mm x 372 mm, 0° tilt angle Pole: 218 mm (dia at base) 75 mm (dia at top) x height (approx. 12 metres) as per lighting detail accounting for required height above and below grade. To be finalised and approved in shop drawings.
Control	<ul style="list-style-type: none">■ Integral DALI dimmable control gear■ Allow for NEMA socket and a daylight sensor■ Allow for Zhaga socket and a PIR sensor■ Both sockets/sensors mounted to underside of fitting. <p>All lighting is to be connected to an adaptive control system controlled via timer, PE cell, and PIR sensor. The system is to regulate the level of illuminance according to the time, levels of natural light, and activity present within the car parks. Refer to the drawings and specification for the lighting control functional description.</p>

When I'm working on a problem,
I never think about beauty. I think
only how to solve the problem. But
when I have finished, if the solution
is not beautiful, I know it is wrong.
Richard Buckminster Fuller

Mechanical Engineering
Lighting Design
Sustainable Design
Electrical Engineering

e : info@steensenvarming.com

STEENSEN VARMING

Accessories

- Mounting accessory (side-entry or post-top slip-over) to be coordinated with final pole top detail. All fixings and mounting to be as per manufacturer's requirements.
- Contractor to allow for an outreach arm for each luminaire head, for coordination of pole positions with final setbacks and locations. Pole locations are indicative only and demonstrate the positions that provide compliance with the LTP's of AS/NZS 1158. Outreach arm detailing to be an extension of the light fitting matching width and height of the spigot slip-over for a streamlined visual outcome. Omit outreach arm bracket if this is not required in the final arrangement – subject to manufacturer's structural engineering requirements.
- Flush fit access panel for maintenance – access via key operated lock or a triangle key – type TBC by the client.
- Base plate, rag bolt assembly and footing by structural engineer – to be below grade.

Location

- As per layouts

Notes

- Pole positions to be coordinated by the Contractor with the final set-back in accordance with AS/NZS 1158 and TTW's requirements (min. 500 mm from stormwater).
- Contractor to provide shop drawings of pole arrangement for approval.
- Footing details are indicative only. Final detail to manufacturer's requirements/engineer's specification to suit site conditions including soil, wind and new civil works.

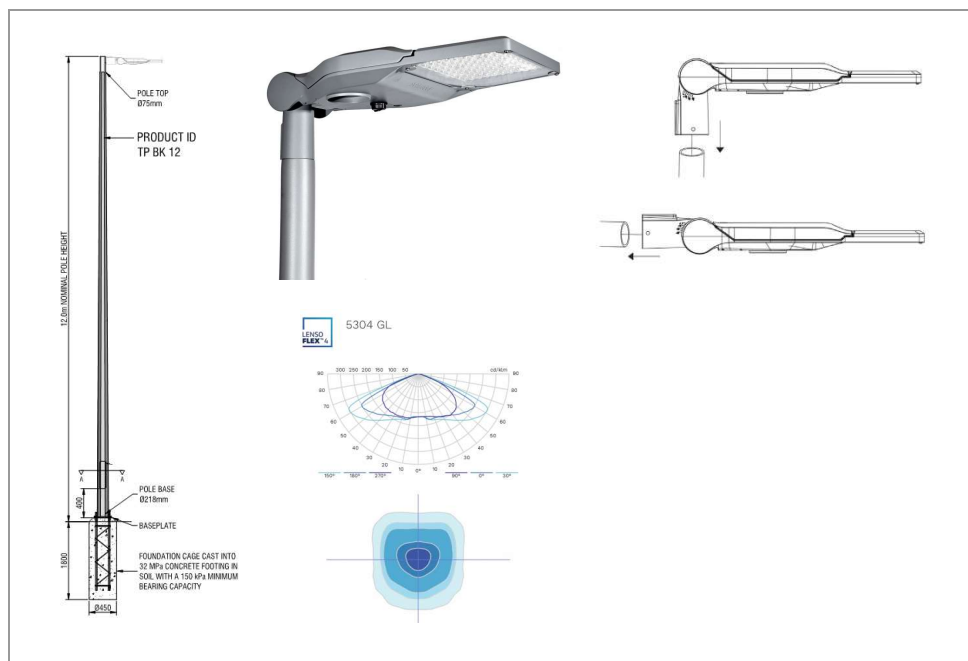

P2

Description	12 -metre-high pole with optic-controlled luminaire (single head)
Model	Luminaire: Schreder IZYLUM EVO 3 Pole: GM Poles Tapered Poles – BK Range
Catalogue No.	Luminaire: IZYLUM EVO 3 5307 40 LEDs @ 400mA WW 730 230V 02-58-001 Glare limiter Pole: TP-BK12 – (TBC by supplier)
Manufacturer	Schreder GM Poles
Supplier	Sylvania Schreder GM Poles
Light Source	LED, 3000K, CRI 70+, 5307 40 LEDs, 49.5W, 6200-7000lm, 400mA L95 100,000 hours (TA <= 25°C) ULOR 0%, ULR 0%
Finish	Luminaire: Polyester powder coated aluminium in RAL 7040 window grey finish, PMMA optic and tempered glass Pole: Standard high quality hot dip galvanised with additional dual coat powdercoat in grey, to match RAL 7040 finish of luminaire or closest standard finish available. Contractor to allow for alternative black finish to pole and luminaire, or custom colour, if requested by the client.
Dimensions	Luminaire: 737 mm x 97 mm x 372 mm, 0° tilt angle Pole: 218 mm (dia at base) 75 mm (dia at top) x height (approx. 12 metres) as per lighting detail accounting for required height above and below grade. To be finalised and approved in shop drawings.
Control	<ul style="list-style-type: none">■ Integral DALI dimmable control gear■ Allow for NEMA socket and a daylight sensor■ Allow for Zhaga socket and a PIR sensor■ Both sockets/sensors mounted to underside of fitting. <p>All lighting is to be connected to an adaptive control system controlled via timer, PE cell, and PIR sensor. The system is to regulate the level of illuminance according to the time, levels of natural light, and activity present within the car parks. Refer to the drawings and specification for the lighting control functional description.</p>

When I'm working on a problem,
I never think about beauty. I think
only how to solve the problem. But
when I have finished, if the solution
is not beautiful, I know it is wrong.
Richard Buckminster Fuller

Mechanical Engineering
Lighting Design
Sustainable Design
Electrical Engineering

e : info@steensenvarming.com

STEENSEN VARMING

Accessories

- Mounting accessory (side-entry or post-top slip-over) to be coordinated with final pole top detail. All fixings and mounting to be as per manufacturer's requirements.
- Contractor to allow for an outreach arm for each luminaire head, for coordination of pole positions with final setbacks and locations. Pole locations are indicative only and demonstrate the positions that provide compliance with the LTP's of AS/NZS 1158. Outreach arm detailing to be an extension of the light fitting matching width and height of the spigot slip-over for a streamlined visual outcome. Omit outreach arm bracket if this is not required in the final arrangement – subject to manufacturer's structural engineering requirements.
- Flush fit access panel for maintenance – access via key operated lock or a triangle key – type TBC by the client.
- Base plate, rag bolt assembly and footing by structural engineer – to be below grade.

Location

- As per layouts

Notes

- Pole positions to be coordinated by the Contractor with the final set-back in accordance with AS/NZS 1158 and TTW's requirements (min. 500 mm from stormwater).
- Contractor to provide shop drawings of pole arrangement for approval.
- Footing details are indicative only. Final detail to manufacturer's requirements/engineer's specification to suit site conditions including soil, wind and new civil works.

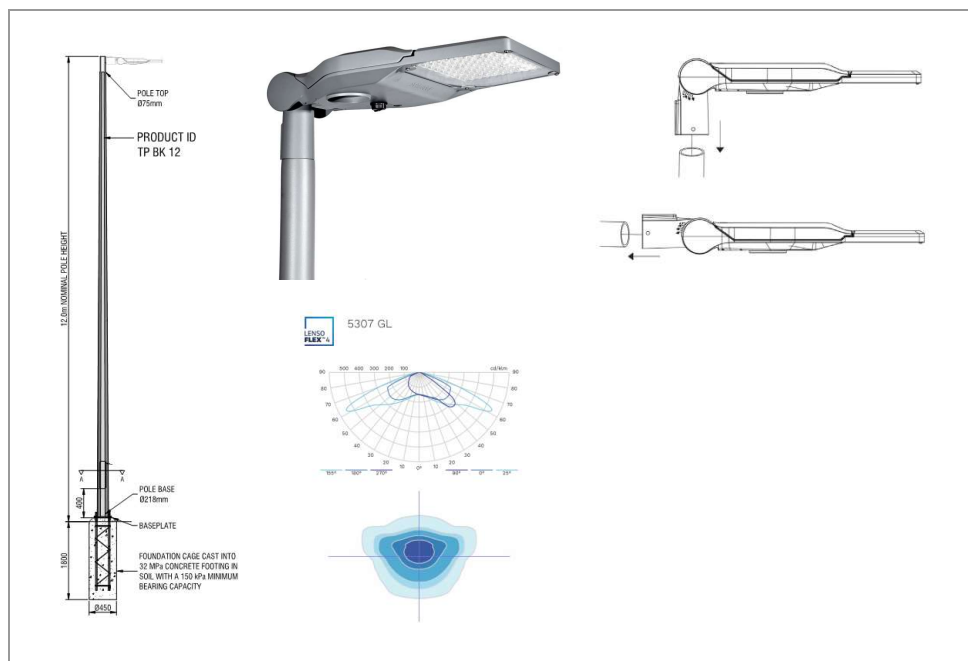

P3

Description	12-metre-high pole with optic-controlled luminaire (single head)
Model	Luminaire: Schreder IZYLUM EVO 3 Pole: GM Poles Tapered Poles – BK Range
Catalogue No.	Luminaire: IZYLUM EVO 3 5306 40 LEDs @ 400mA WW 730 230V 02-58-001 Glare limiter Pole: TP-BK12 – (TBC by supplier)
Manufacturer	Schreder GM Poles
Supplier	Sylvania Schreder GM Poles
Light Source	LED, 3000K, CRI 70+, 5306 40 LEDs, 49.5W, 6200-7000lm, 400mA L95 100,000 hours (TA <= 25°C) ULOR 0%, ULR 0%
Finish	Luminaire: Polyester powder coated aluminium in RAL 7040 window grey finish, PMMA optic and tempered glass Pole: Standard high quality hot dip galvanised with additional dual coat powdercoat in grey, to match RAL 7040 finish of luminaire or closest standard finish available. Contractor to allow for alternative black finish to pole and luminaire, or custom colour, if requested by the client.
Dimensions	Luminaire: 737 mm x 97 mm x 372 mm, 0° tilt angle Pole: 218 mm (dia at base) 75 mm (dia at top) x height (approx. 12 metres) as per lighting detail accounting for required height above and below grade. To be finalised and approved in shop drawings.
Control	<ul style="list-style-type: none">■ Integral DALI dimmable control gear■ Allow for NEMA socket and a daylight sensor■ Allow for Zhaga socket and a PIR sensor■ Both sockets/sensors mounted to underside of fitting. <p>All lighting is to be connected to an adaptive control system controlled via timer, PE cell, and PIR sensor. The system is to regulate the level of illuminance according to the time, levels of natural light, and activity present within the car parks. Refer to the drawings and specification for the lighting control functional description.</p>

When I'm working on a problem,
I never think about beauty. I think
only how to solve the problem. But
when I have finished, if the solution
is not beautiful, I know it is wrong.
Richard Buckminster Fuller

Mechanical Engineering
Lighting Design
Sustainable Design
Electrical Engineering

e : info@steensenvarming.com

STEENSEN VARMING

Accessories

- Mounting accessory (side-entry or post-top slip-over) to be coordinated with final pole top detail. All fixings and mounting to be as per manufacturer's requirements.
- Contractor to allow for an outreach arm for each luminaire head, for coordination of pole positions with final setbacks and locations. Pole locations are indicative only and demonstrate the positions that provide compliance with the LTP's of AS/NZS 1158. Outreach arm detailing to be an extension of the light fitting matching width and height of the spigot slip-over for a streamlined visual outcome. Omit outreach arm bracket if this is not required in the final arrangement – subject to manufacturer's structural engineering requirements.
- Flush fit access panel for maintenance – access via key operated lock or a triangle key – type TBC by the client.
- Base plate, rag bolt assembly and footing by structural engineer – to be below grade.

Location

- As per layouts

Notes

- Pole positions to be coordinated by the Contractor with the final set-back in accordance with AS/NZS 1158 and TTW's requirements (min. 500mm from stormwater).
- Contractor to provide shop drawings of pole arrangement for approval.
- Footing details are indicative only. Final detail to manufacturer's requirements/engineer's specification to suit site conditions including soil, wind and new civil works.

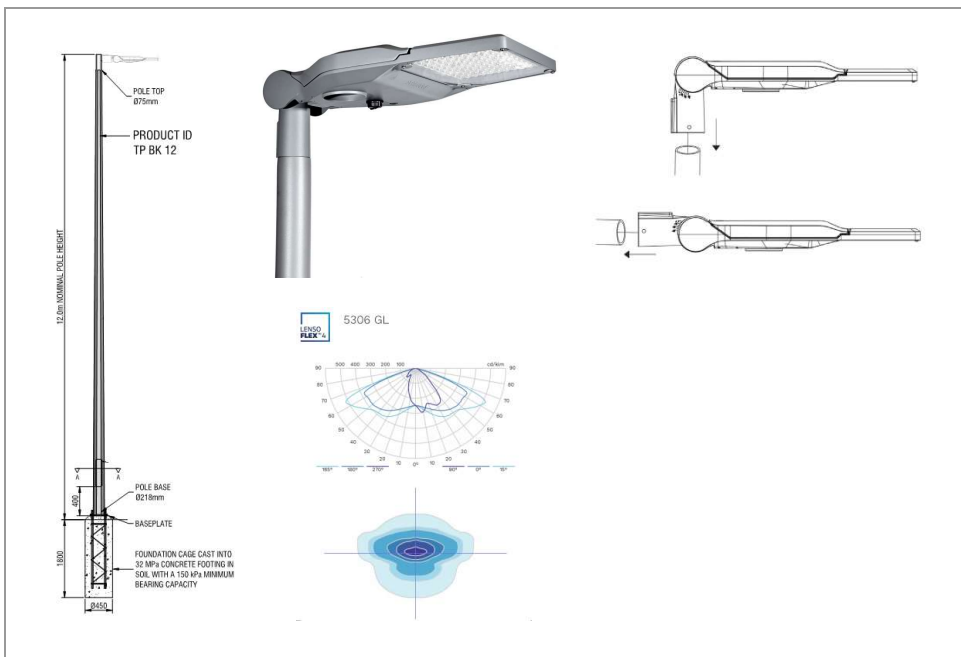

P4

Description	12 -metre-high pole with 2 x optic-controlled luminaire (double head)
Model	Luminaires: Schreder IZYLUM EVO 3 Pole: GM Poles Tapered Poles – BK Range
Catalogue No.	Luminaires: IZYLUM EVO 3 5307 40 LEDs @ 400mA WW 730 230V 02-58-001 Clare limiter Pole: TP-BK12 – (TBC by supplier)
Manufacturer	Schreder GM Poles
Supplier	Sylvania Schreder GM Poles
Light Source	LED, 3000K, CRI 70+, 5307 40 LEDs, 49.5W, 6200-7000lm, 400mA L95 100,000 hours (TA <= 25°C) ULOR 0%, ULR 0%
Finish	Luminaires: Polyester powder coated aluminium in RAL 7040 window grey finish, PMMA optic and tempered glass Pole: Standard high quality hot dip galvanised with additional dual coat powdercoat in grey, to match RAL 7040 finish of luminaire or closest standard finish available. Contractor to allow for alternative black finish to pole and luminaire, or custom colour, if requested by the client.
Dimensions	Luminaire: 737 mm x 97 mm x 372 mm, 0° tilt angle Pole: 218 mm (dia at base) 75 mm (dia at top) x height (approx. 12 metres) as per lighting detail accounting for required height above and below grade. To be finalised and approved in shop drawings.
Control	<ul style="list-style-type: none">■ Integral DALI dimmable control gear■ Allow for NEMA socket and a daylight sensor■ Allow for Zhaga socket and a PIR sensor■ Both sockets/sensors mounted to underside of fitting. <p>All lighting is to be connected to an adaptive control system controlled via timer, PE cell, and PIR sensor. The system is to regulate the level of illuminance according to the time, levels of natural light, and activity present within the car parks. Refer to the drawings and specification for the lighting control functional description.</p>

When I'm working on a problem,
I never think about beauty. I think
only how to solve the problem. But
when I have finished, if the solution
is not beautiful, I know it is wrong.
Richard Buckminster Fuller

Mechanical Engineering
Lighting Design
Sustainable Design
Electrical Engineering

e : info@steensenvarming.com

STEENSEN VARMING

Accessories

- Mounting accessories (side-entry) to be coordinated with final pole top detail. All fixings and mounting to be as per manufacturer's requirements.
- Contractor to allow for an outreach arm for each luminaire head, for coordination of pole positions with final setbacks and locations. Pole locations are indicative only and demonstrate the positions that provide compliance with the LTP's of AS/NZS 1158. Outreach arm detailing to be an extension of the light fitting matching width and height of the spigot slip-over for a streamlined visual outcome. Omit outreach arm bracket if this is not required in the final arrangement – subject to manufacturer's structural engineering requirements.
- Flush fit access panel for maintenance – access via key operated lock or a triangle key – type TBC by the client.
- Base plate, rag bolt assembly and footing by structural engineer – to be below grade.

Location

- As per layouts

Notes



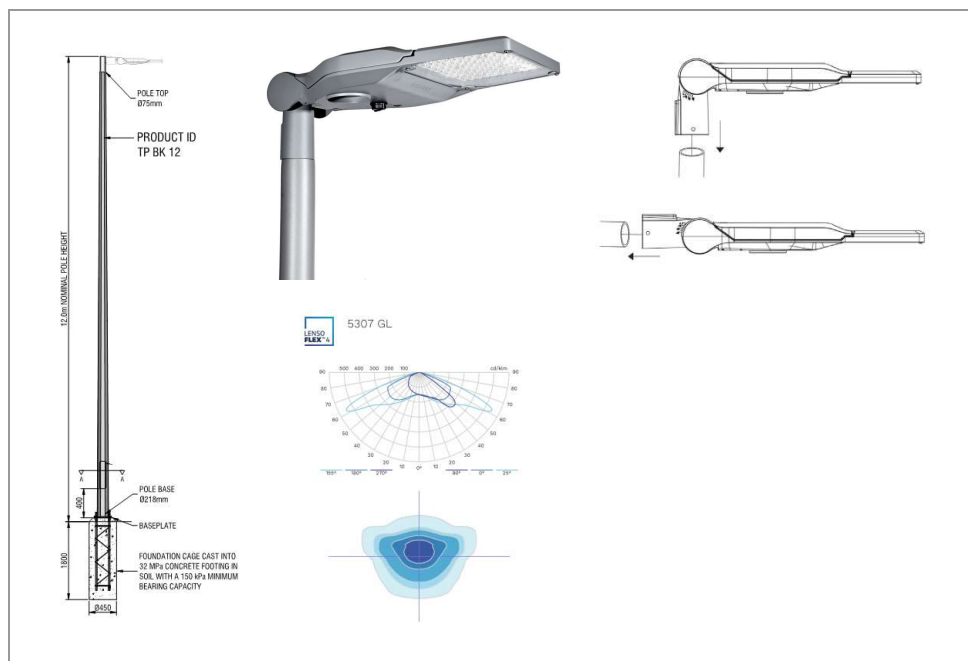

- Pole positions to be coordinated by the Contractor with the final set-back in accordance with AS/NZS 1158 and TTW's requirements (min. 500mm from stormwater).
- Contractor to provide shop drawings of pole arrangement for approval.
- Footing details are indicative only. Final detail to manufacturer's requirements/engineer's specification to suit site conditions including soil, wind and new civil works.



2.0 Electrical Equipment Datasheets

Type and Manufacturer

The electrical items in these data sheets intend to indicate a preference for a specific make and model which have been specifically selected as they incorporate features required in the design including materials, shape, output, and quality. Steensen Varming have specified equipment items on an equal and approved basis.

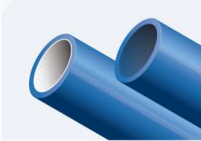
<u>Item</u>	<u>Image</u>	<u>Details</u>
Electrical Distribution		
Load Centre		<p>Description: Electrical distribution board Model: Clipsal Resi MAX Consumer Switchboard 12 pole Supplier: Clipsal or approved equal Notes: Or equal and approved. Refer to the electrical specification and drawings for distribution board details.</p>
Distribution Board Circuit Breakers		<p>Description: MCCBs & RCBOs Model: Various Catalogue: Various Supplier: Schneider or equal and approved by the Principal's Authorised Person</p>
External Enclosure for Distribution Board		<p>Description: Enclosure Model: Various Catalogue: Various Supplier: Schneider, Eaton or equal and approved by the Principal's Authorised Person, IP 54 minimum</p>
XLPE Submain Cables		<p>Description: XLPE multicore Model: Various Supplier: Prysmian, Olex or equal and approved by the Principal's Authorised Person Notes: Refer to drawings for sizes of cabling</p>
HDPE Conduits		<p>Description: HDPE Conduits Model: Smoothwall with UV protectant Supplier: Dura-line Notes: Or approved equal. Conduits to be sized for cabling with spare space for ease of pulling and replacing cabling if needed in future, to be installed directly underground.</p>