



WIND ENGINEERING  
CONSULTANTS

QUALITATIVE WIND ASSESSMENT  
CPP PROJECT 19614  
27 MAY 2025

# Indigenous Centre of Excellence

*171 Victoria Road, Parramatta*

CPP Wind Engineering  
Consultants

2/500 Princes Highway  
St Peters NSW 2044

[Info-syd@cppwind.com](mailto:Info-syd@cppwind.com)

[cppwind.com](http://cppwind.com)

PREPARED FOR:

Western Sydney University  
Locked Bag 1797  
Penrith NSW 2751

PREPARED BY:

Tomer Libman  
Project Engineer  
[tlibman@cppwind.com](mailto:tlibman@cppwind.com)

Joe Paetzold, PhD  
Engineering Manager  
[jpaetzold@cppwind.com](mailto:jpaetzold@cppwind.com)

## Executive Summary

A qualitative assessment of the Indigenous Centre of Excellence proposed as part of a State Significant Development application to be built at the Western Sydney University Parramatta South campus was conducted to provide an initial assessment of the surrounding pedestrian wind environment. The assessment was based on the local wind climate, CPP's experience in the region and on comparable projects, and the characteristics of the proposed development.

The wind environment around the development is likely to be generally suitable for pedestrian walking style activities from a comfort perspective with reference to the Lawson criteria for the majority of the site. Areas intended for long term stationary activity such as seating and dining are likely to require treatment to ensure they are suitable for their intended use. The north-western side of the site is expected to be subjected to elevated wind speeds for winds from the west and south-west; mitigation measures have been suggested.

Relatively windy conditions are expected to occur at the Level 4 outdoor areas. The requirements for mitigating stronger wind conditions will depend on the intended use of these areas.

This report is a high level qualitative assessment based on basic features of the local wind climate and proposed built environment.

## Document Tracking and Version Control

Revision	Date	Prepared By	Reviewed By	Approved By
R00	9 April 2024	Tomer Libman	Joe Paetzold, PhD	Joe Paetzold, PhD
R01	1 May 2024	Tomer Libman	Joe Paetzold, PhD	Joe Paetzold, PhD
R02	8 July 2024	Koa Hatchett	Joe Paetzold, PhD	Joe Paetzold, PhD

REVISION	RELEVANT INFORMATION
	Date Issued: 27 May 2025
	Prepared by: Tomer Libman
R03	Reviewed by: Joe Paetzold, PhD
	Approved by: Joe Paetzold, PhD
	Document Name: CPP19614_Indigenous Centre of Excellence_REP_DS_PW_R03.pdf

# Contents

	1
Executive Summary	2
Document Tracking and Version Control	3
1. Background	5
Site Description and location	5
Project Description	6
2. Introduction	7
General information	7
3. Wind Climate	9
4. Wind Assessment Criteria	11
5. Assessment	13
Site Description	13
Winds from the West	13
Winds from the South-East	14
Winds from the south-West	14
Summary – Public Domain	14
Wind conditions within the development	15
6. Conclusion	17
References	18
Appendix A – Wind Flow Mechanisms	19
Appendix B - Wind Impact Planning Guidelines	21

# 1. Background

## SITE DESCRIPTION AND LOCATION

The Western Sydney University South Parramatta Campus is located within the City of Parramatta Local Government Area (LGA).

The site is legally described as Lot 100 and 101 in DP 816829, and largely comprises the P1 Car Park and grassed embankments along Fifth Street in the northern portion of the wider site campus.

The site is located approximately 3km east of the Parramatta CBD, and is also located adjacent to the recently completed Parramatta Light Rail Corridor, with direct access to the Yallamundi Light Rail stop.

The site location and project boundary is identified in Figure 1.



Figure 1: Western Sydney University Parramatta South Campus locational context.  
Source: Nearmap/Ethos Urban

## PROJECT DESCRIPTION

The Applicant seeks development consent for the construction of a new state-of-the-art Indigenous Centre of Excellence as a new tertiary education facility on campus. The Indigenous Centre of Excellence project is funded by the NSW Government's Western Sydney Infrastructure Grants Program in association with Western Sydney University. The new Indigenous Centre of Excellence will be an important asset for both the University and local community alike, providing a space for the commitment to advancing Indigenous education, leadership, and reconciliation.

This State Significant Development Application (SSDA) specifically seeks detailed approval for the following works:

- Site preparation including demolition of the existing car park, tree removal and installation of inground utility infrastructure services.
- Construction of a four-storey Indigenous Centre of Excellence encompassing the following facilities:
  - Outdoor amphitheatre,
  - Cinema and lecture theatre,
  - Artist studios and gallery exhibition space,
  - Teaching workspaces and general study areas,
  - Library and other educational research spaces,
  - Multi-functional recreational sports court, with ancillary amenities, and
  - Astronomy garden.
- Construction of hardstand paving and line marking to accommodate new parking areas, including:
  - 13 spaces on the existing P1 car park site, adjacent to the new dedicated arrival zone to the proposed ICoE,
  - 107 spaces proposed in new western car park to the west of Bridge Street, adjacent to the existing oval, and
  - 181 spaces proposed in new eastern car park on the southern side of Fifth Street, adjacent to the new ICoE.
- Landscaping works to provide outdoor educational and recreational spaces.

This report responds to the SSD-64916225 Secretary's Environmental Assessment Requirement (SEARs) number 5 (Environmental Amenity) which was issued by the Department of Planning, Housing and Infrastructure on 21st November 2023.

## 2. Introduction

### GENERAL INFORMATION

The assessment of the wind environment around developments can ensure adverse impacts are minimized and inform designers about the suitability of outdoor areas for their intended uses. Where necessary, design modifications can be made, or intervention measures added to mitigate areas with the potential for excessive wind speeds. The surrounding terrain is comprised primarily of low-rise suburban development, Figure 1.

The proposed development is comprised of a C-shaped structure, with inward-slanting edges, reaching a maximum height of about 22 m above ground level, Figure 2. As it is slightly larger than most of the surrounding structures, the addition of the proposed development is expected to have some impact on the local wind conditions, and the extents are broadly discussed in this report.

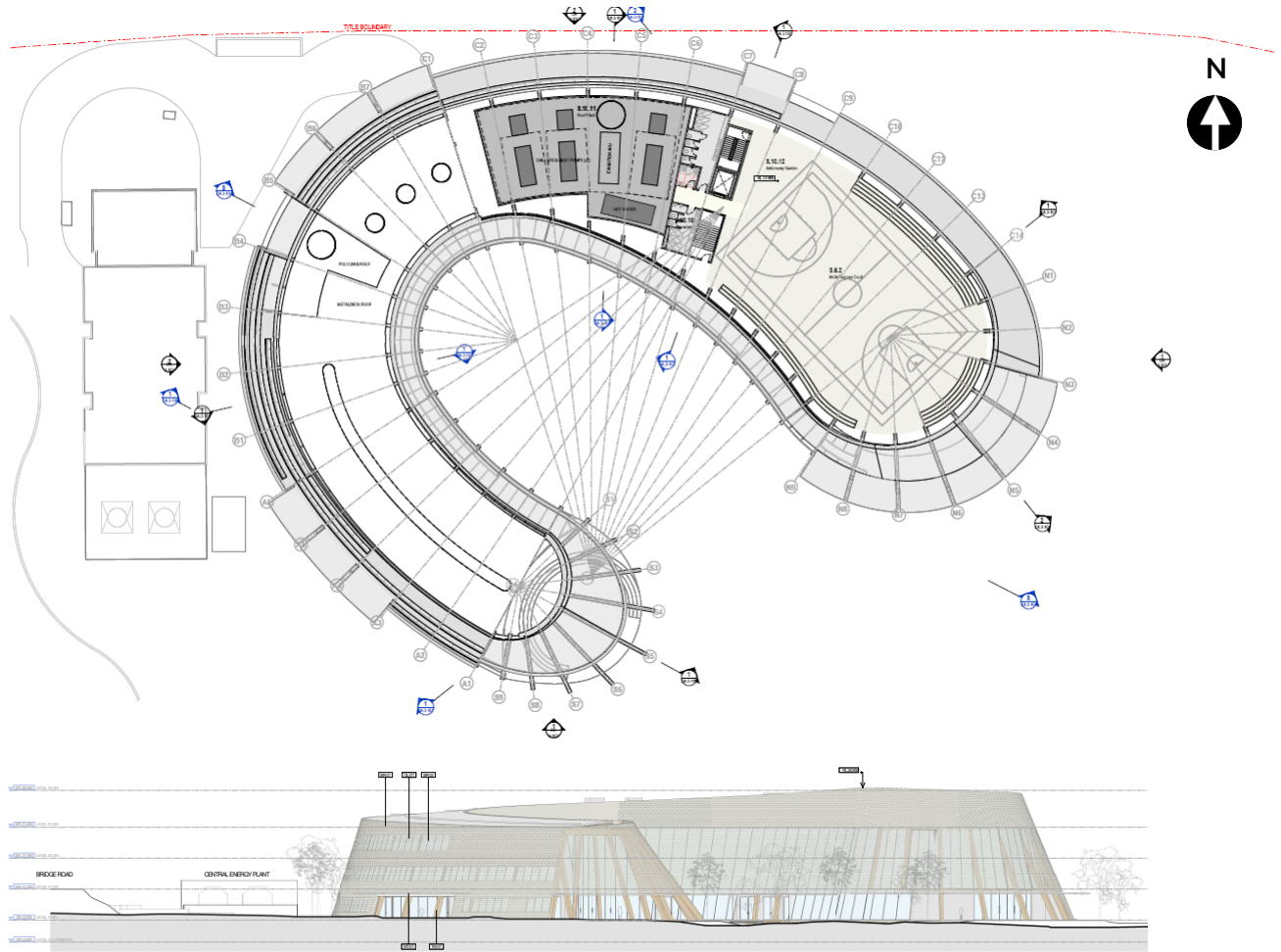

Figure 2: Level 3 plan (top) and South Elevation (bottom) of proposed development

### 3. Wind Climate

The proposed development lies approximately 13 km to the north-north-east of the Bankstown Airport Bureau of Meteorology anemometer, which provides the best source of historical wind data for the project. To enable a qualitative assessment of the wind environment, the wind frequency and direction information measured by the Bureau of Meteorology at a standard height of 10 m from 1995 – 2022 have been used in this analysis.

The wind rose for Bankstown Airport is shown in Figure 3. The arms of the wind roses point in the direction from where the wind is blowing, the width and color of the arm represent the wind speed, and the length of the arm indicates the percent of the time that the wind blows for that combination of speed and direction.

The distribution and frequency of winds on an annual basis were analyzed to assess the project with regards to wind comfort and safety. As can be seen from the wind rose in Figure 3, winds from the west and south-east directions are predominant, with secondary winds occurring from the south and south-west directions. This wind assessment is structured around these prevailing wind directions.

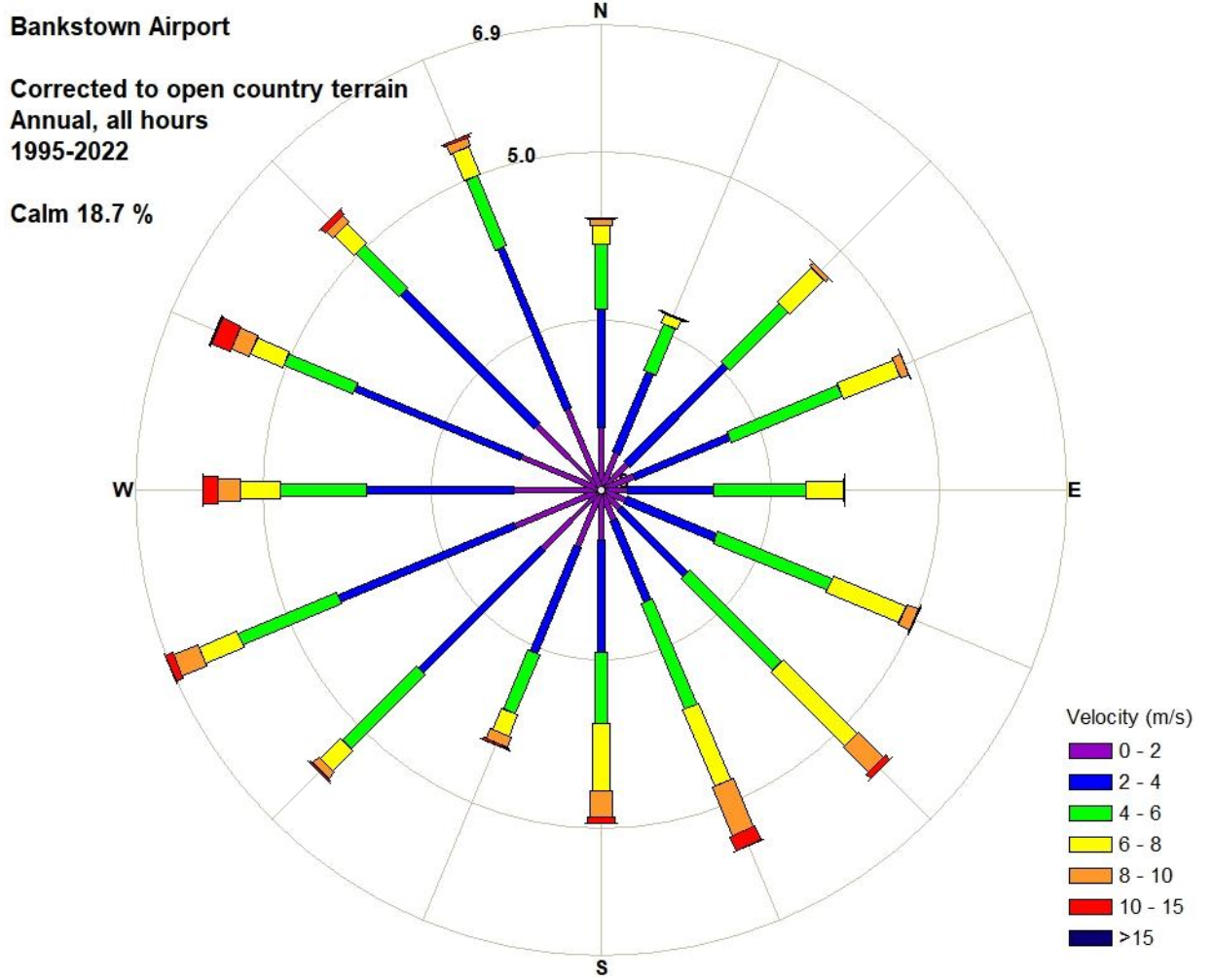

Figure 3: Probability of Wind Speeds by Direction: Bankstown Airport (1995 – 2022, All Hours)

## 4. Wind Assessment Criteria

A number of researchers have suggested quantitative methods for assessing wind comfort and safety based on estimated wind speeds and local climate statistics. These criteria provide a means of evaluating the wind amenity of location based on the frequency of threshold wind speeds, noting that pedestrians will tolerate higher wind speeds for a shorter time period than lower speeds. The comfort criteria also allow planners to assess the usability, with respect to the wind environment, of different locations for various purposes.

NSW Department of Planning's SEAR does not specify a method of assessing wind comfort or safety for this site. CPP uses a modified form of the widely-accepted pedestrian-level wind criteria developed by Lawson (1990), consistent with the City of Parramatta's wind criterion in Section 5.4.7 of the DCP (2023). Lawson's criteria are divided into separate categories of comfort and distress (safety).

Lawson's criteria are based on wind speeds exceeded 5% of the time, and are described as categories for comfort ranging from 'Pedestrian Sitting' to 'Business Walking', allowing planners to judge the usability of locations for various intended purposes. The criteria also include a distress rating, for safety assessment, which is based on occasional (once or twice per year) wind speeds, to identify locations where wind speeds may be hazardous to pedestrians.



The categories and criteria are specified in Table 1. In general, wind conditions comfortable for Sitting and Standing are considered appropriate for areas such as entrances where pedestrians are likely to gather for longer durations, while wind conditions comfortable for Casual Walking and Business Walking are more appropriate for sidewalks where pedestrians are actively in transit. Locations rated as Uncomfortable are generally less suitable for most pedestrian activities and wind control solutions are often sought. Whether mitigation is needed at a location depends upon the intended pedestrian use of the location.

Satisfaction of the safety rating is generally required for areas accessible to the general public. A rating of 'Able-Bodied' may be acceptable for areas with managed access or where pedestrians are unlikely to be present under adverse conditions.

Assessment using the Lawson criteria is preferred to methods based on once per annum gust speeds such as Melbourne (1978) as it is based on more regularly occurring wind speeds relevant to perception by pedestrians and uses a combined probability integrated over all directions. In addition, it is less susceptible to variations in turbulence levels in urban environments while still considering the impact of short-duration gusts.

Pedestrians' perception of wind can often be subjective and vary depending on regional difference in wind climate and thermal conditions, as well as by individual. Calibration to the local wind environment should be taken into account when evaluating predicted wind comfort conditions. Note that the ratings of 'Uncomfortable' and 'Safety' are the words of the published wind criteria and applicability may vary by project and location.



Table 1: Wind Comfort and Safety criteria (after Lawson, 1990)

COMFORT RATING	$U_{EQUIV}^*$	DESCRIPTION
 Dining**	< 2 m/s	Calm / light breezes suitable for outdoor restaurant uses, seating areas, and other amenities based on CPP experience.
 Sitting	2-4 m/s	Calm or light breezes suitable for long duration seating areas, and other amenities.
 Standing	4-6 m/s	Gentle breezes suitable for sitting for shorter periods, main entrances and bus stops where pedestrians may linger.
 Pedestrian Walking	6-8 m/s	Moderate winds appropriate for window shopping and strolling along a downtown street, or park.
 Business Walking/Non-Active Frontage	8-10 m/s	Relatively high speeds that can be tolerated if one's objective is to walk, run, or cycle.
 Uncomfortable	> 10 m/s	Strong winds unacceptable for all pedestrian activities; wind mitigation is typically required.

\* $U_{Equiv} = \text{Max}(U_{Mean}, U_{Gust} / 1.85)$ .

\* $U_{Equiv}$  speeds are based on an annual exceedance of 5% (~8 hours / week) assessed over all hours.

\*\* For regular outdoor dining, and in semi-enclosed spaces, it has been the experience of CPP that the comfort rating of Sitting may be windier than desired and a comfort criterion of 4 m/s or less may be more applicable.

SAFETY RATING	$U_{GUST}^*$	DESCRIPTION
 Pass	< 23 m/s	Meets wind safety criterion.
 Fail	>23 m/s	Excessive wind speeds that can adversely affect a pedestrian's balance and footing. Wind mitigation is often required.

\* $U_{Gust}$  speeds are based on an annual exceedance of 0.1% (~1 / year) assessed over all hours.

## 5. Assessment

### SITE DESCRIPTION

The development site is surrounded in most directions by low-rise buildings, with a region of parkland to the south and west. Topography surrounding the site is relatively flat from a wind perspective and unlikely to significantly affect the wind climate at the site. Winds in such surrounds tend to experience less channelling than areas with many tall structures, with local effects instead being dictated by exposed buildings and their relation to prevailing strong wind directions. Several wind flow mechanisms such as downwash and channelling flow are described in Appendix A and the effectiveness of some common wind mitigation measures are described in Appendix B

The subject site is located on a block bounded by Victoria Road to the north and Fifth Street to the south with Bridge Street to the west and Railway Street to the east of the site. The proposed development consists of a single structure with a C-shaped planform, with inward-sloping edges. A ground floor plan is shown in Figure 4.

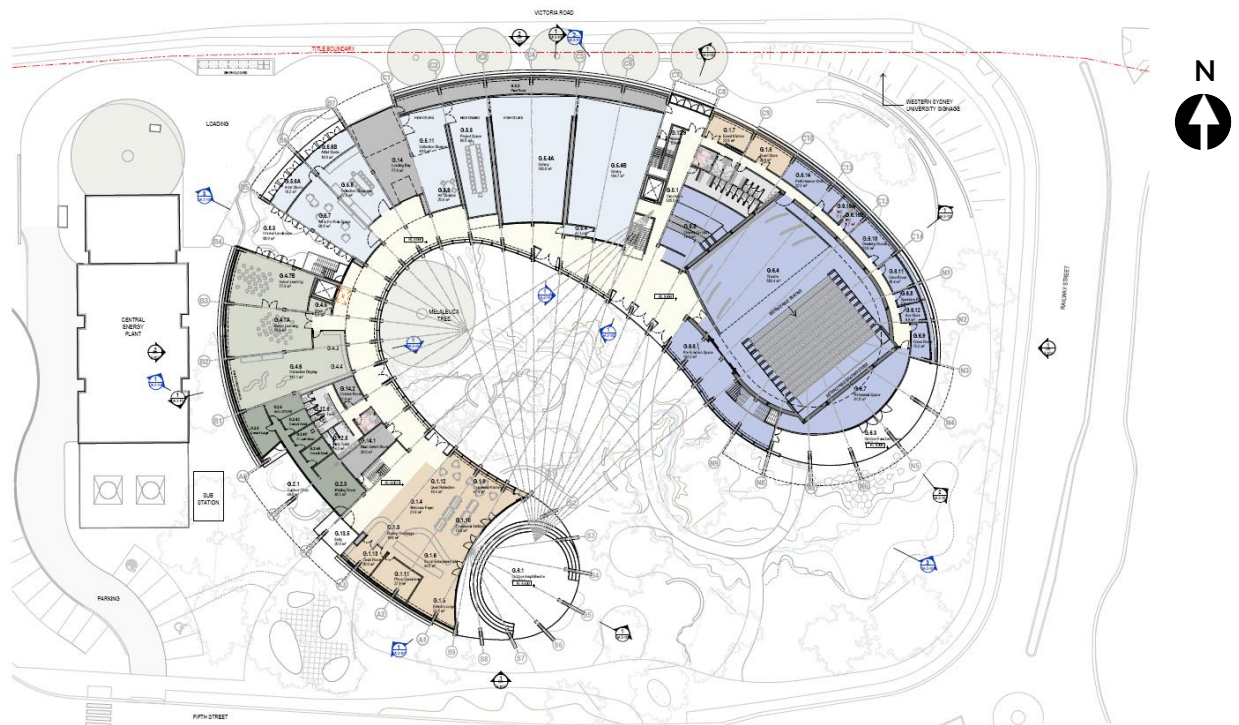

Figure 4: Ground floor plan of proposed development

### WINDS FROM THE WEST

Winds from the western quadrant will approach the site over a region of suburban development, with the northern part of the Parramatta CBD about 2km away from the site. The proposed planting around the site, shown in Figure 4, will offer some shielding from direct winds on the upper levels from all directions. However, due to the height of the proposed landscaping, shown in Figure 2, pedestrian level areas will remain relatively unshielded from the predominant winds.

The convex curvature of the building on the western side would tend to direct flow around the building, increasing wind speeds along the majority of the pedestrian level during westerly winds. The central energy plant and planting to the immediate west of the building would provide some shielding for part of its western perimeter from direct winds and aid in diverting incoming wind from the west quadrant over and around the building. The area near the loading bay at the north-western part of the site may be subjected to relatively strong wind conditions for winds from the west quadrant, as well as the area around the south-western accessway. These conditions would be acceptable for the intended use of the loading bay, however the area around the south-western entrance would require dense local screening such as planting at ground level of 2-3 m in height.

Wind conditions within the recessed south-eastern side of the site are expected to remain generally mild due to the shielding provided by the massing of the development itself.

### **WINDS FROM THE SOUTH-EAST**

Winds from the south-east quadrant will approach over a large region of industrial development.

For winds from the south-east, the building's inward slanting on this side would divert some flow toward the roof, and cause a minor increase in wind speeds on the Level 3 outdoor court and garden. However, wind conditions will remain acceptable for general public access.

Due to the concave curvature of the building on the south-eastern side, flow from the south-east is likely to accelerate up the slanted building rather than around it. This would create milder areas away from the centre of the recessed area, but slightly increase wind speeds up at the Level 3 outdoor areas. The roof plant itself would help to improve conditions at Level 3. Flow around the building would also lead to slightly accelerated wind speeds at the south-western and eastern side of the site at ground level.

All areas around the site are expected to pass the safety criterion during winds from the south-east.

### **WINDS FROM THE SOUTH-WEST**

Winds from the south-west quadrant will approach over a large region of industrial development, with some open parkland close to the site.

Similarly to winds from the western quadrant, the convex curvature of the building accelerates flow around the building, with conditions at ground level on the north-western side of the building being subjected to strong winds from the south-west. The space between the building and the central energy plant may experience some channelling flow for these wind directions. Also similarly, the south-eastern side of the site is shielded from these winds and conditions there will remain relatively mild.

### **SUMMARY – PUBLIC DOMAIN**

For most locations, wind conditions within the proposed development site are expected to remain similar to the existing wind conditions. From a pedestrian comfort perspective, the wind environment around the proposed development site for the majority of areas is likely to be classified as acceptable for pedestrian standing or walking under the Lawson comfort criterion. These pedestrian comfort levels would be suitable for public accessways, and for stationary short-term exposure activities. More protected areas such as parts of the central courtyard would have milder wind conditions meeting the pedestrian sitting criterion. The west and north-west part of the site (near the loading bay) would be subjected to strong winds for approaching winds from the west and south-west quadrants. If this area is to be utilised for public accessways and stationary activities, landscaping or local screening at ground level of 2-3 m in height may be utilised for wind mitigation.

## WIND CONDITIONS WITHIN THE DEVELOPMENT

### GROUND LEVEL AND OUTDOOR AMPHITHEATRE

Entrances on the ground level are found on the south-western (near the community and arrival hall) and western (internal landscape) sides of the site. Due to the differential pressure between the concave and convex sides of the building for either westerly or south-easterly winds, there is potential for internal flow issues to occur if doors on both the concave and convex side are open. Additionally, during winds from the south-west, the community space entrance and the internal landscape entrance will also have a differential pressure between them, creating internal flows if the landscape entrance is open. These differential pressures may also cause undesirable wind conditions indoors on the ground level, such as in the community/arrival area, Section 12.11, and Section 6.6.

Given the expected usage time of the various entrance doors, with the main south-west entrance being used for the majority of foot traffic, and the doors on the convex side of the building being used sparingly, and the size of the interior space, internal flows would be expected to be relatively mild through most of the space, and only significant at the entrances when they are both open. If further amelioration is desired, an airlock-style entrance such as a revolving door could be considered.

Wind conditions on the outdoor amphitheatre will tend to be relatively mild towards the centre of the space. For winds from the west, the amphitheatre would be shielded by the building's massing, while for winds from the south-west and south-east, flow would move through the amphitheatre space. Wind speeds would not increase significantly on the perimeter from flow channelling, as the porous façade above Level 1 would allow some of the flow through the space to occur above pedestrian level. If milder conditions are desired in the amphitheatre, closing the space on one side (or creating a sliding-door façade) could be considered.

### LEVEL 1 – 3 OUTDOOR AREAS

On the Outdoor Maker terrace on Level 1 and the northern terrace on Level 2, wind conditions are likely to be mild, as these terraces are within an interior volume, and are sealed from all other directions. Wind conditions would likely be rated as <4 m/s under the comfort criteria.

For the western terrace on Level 2, wind conditions are also likely to be relatively mild, as the interior side of the terrace has a solid wall. There would be some flow moving upward due to the open roof, however this flow is unlikely to affect the comfort conditions in the space, especially within the western section where the roof is semi-solid.

For the Level 3 astronomy garden and basketball court, differential pressure between the convex and concave façades would accelerate winds through the porous openings, potentially creating windy conditions in these areas depending on the porosity of the façade.

The requirements for wind amelioration for these areas will depend on the intended use of these spaces. For medium-term stationary activity that may be required for the garden, the proposed trees are expected to mitigate conditions to a small extent. Decreasing the porosity of the façade in this region would be suggested, shown in Figure 5. However, while it is beyond the scope of this discussion, the potential for aeroacoustic noise should also be considered when making this change. For short-term stationary or walking activities likely for the basketball court, these mitigation measures are less critical, especially if the porosity of the façade is low.

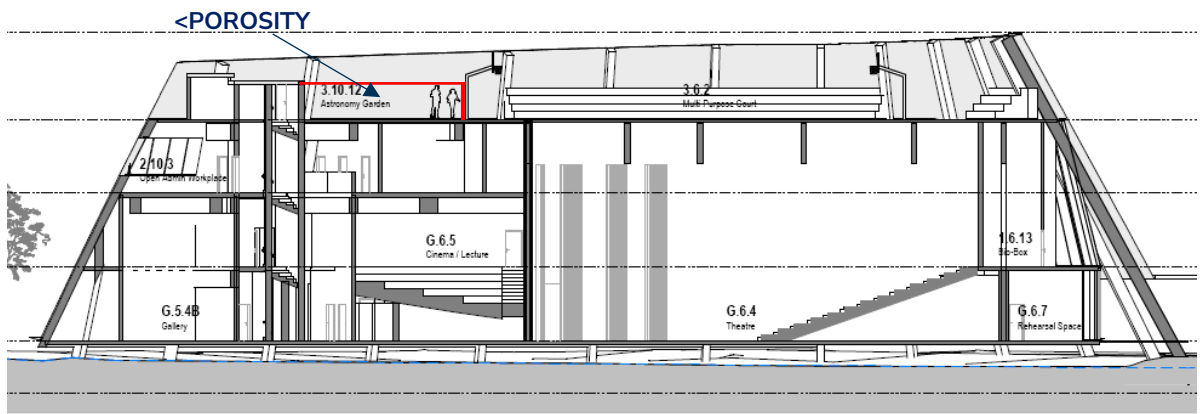

Figure 5: Suggested mitigation for Level 3.

## 6. Conclusion

Cermak Peterka Petersen Pty. Ltd. has provided a qualitative assessment of the impact of the proposed Indigenous Centre of Excellence project on the local wind environment in and around the development site. Being slightly larger than most surrounding structures, the proposed development will have some effect on the local wind environment, though any changes are not expected to be significant from the perspective of pedestrian comfort or safety. Wind conditions around the majority of the development are expected to be classified as acceptable for pedestrian standing or walking from a Lawson comfort perspective and pass the safety criterion. The south-eastern courtyard, and Level 1 and 2 terraces are expected to have milder conditions, suitable for pedestrian sitting activities. Conditions on the north-west side of the site around the loading bay, the south-west entrance area and, to a lesser extent, the Level 3 outdoor areas are expected to be subjected to windier conditions. These areas would require specific mitigation measures, such as local screening/planting on the ground level, or decreased porosity on the façade at Level 3.

## References

Lawson, T.V. (1990), "The Determination of the Wind Environment of a Building Complex before Construction" Department of Aerospace Engineering, University of Bristol, Report Number TVL 9025.

Melbourne, W.H., 1978, Criteria for Environmental Wind Conditions, Journal of Wind Engineering and Industrial Aerodynamics, Vol.3, No.2-3, pp.241-249.

City of Parramatta, 2023, Development Control Plan Part 5 – Environmental Management, pp. 83-85

## Appendix A – Wind Flow Mechanisms

When the wind hits a large, isolated building, the wind is accelerated down and around the windward corners, Figure A1 this flow mechanism is called downwash and causes the windiest conditions at ground level on the windward corners and sides of the building. In Figure A1, smoke is being released into the wind flow to allow the wind speed, turbulence, and direction to be visualised. The image on the left shows smoke being released across the windward face, and the image on the right shows smoke being released into the flow at about third height in the centre of the face.

Techniques to mitigate the effects of downwash winds on pedestrians include the provision of horizontal elements, the most effective being a podium to divert the flow away from pavements and building entrances. Awnings along street frontages perform a similar function, and the larger the horizontal element, the more effective it will be in diverting the flow.

Channelling occurs when the wind is accelerated between two buildings or along straight streets with buildings on either side.

Figure A2 shows the wind at mid and upper levels on a building being accelerated substantially around the corners of the building. When balconies are located on these corners, they are likely to be breezy, and will be used less by the owner due to the regularity of stronger winds. Owners quickly become familiar with when and how to use their balconies. If the corner balconies are deep enough, articulated, or have regular partition privacy fins, then local calmer conditions can exist.

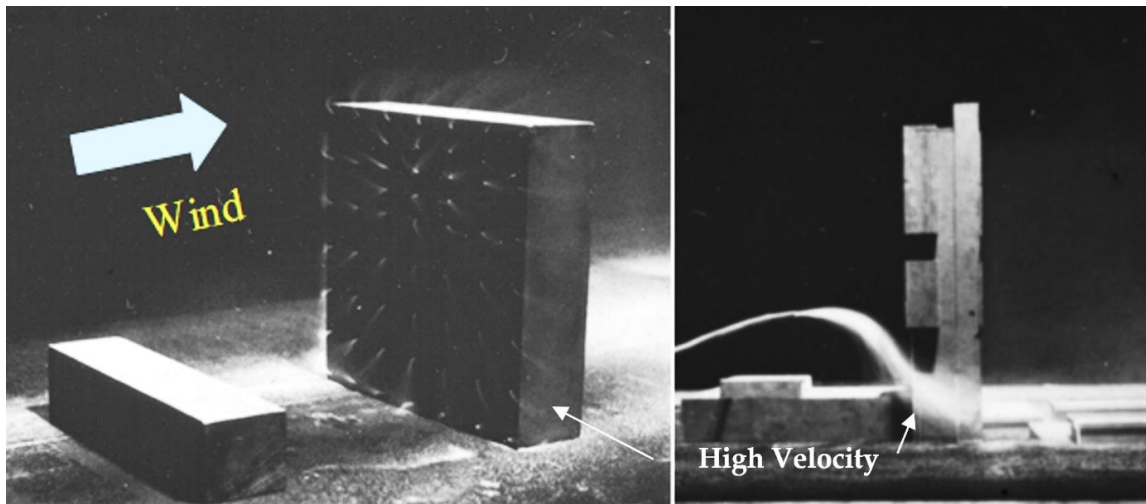

Figure A1: Flow visualisation around a tall building.

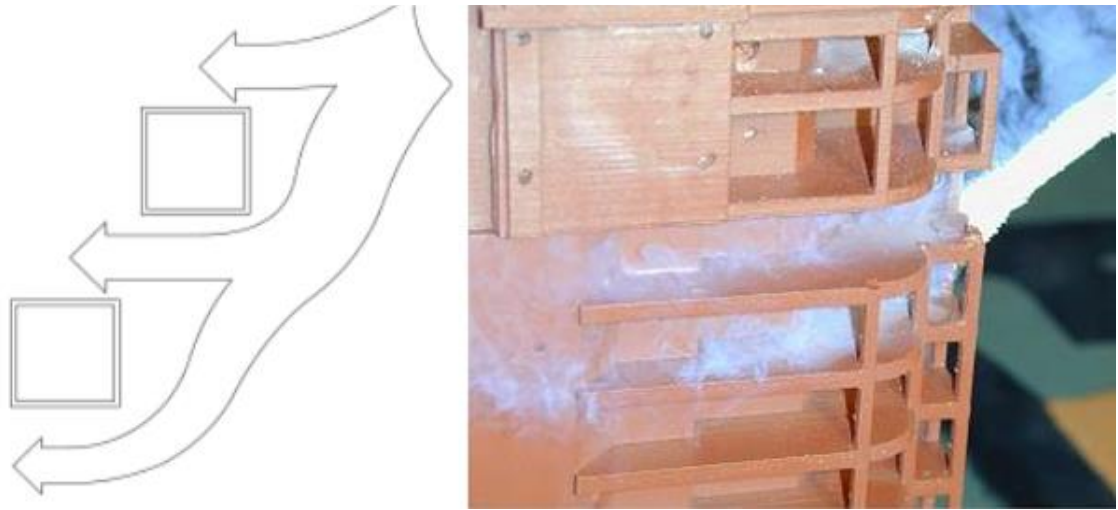

Figure A2: Channelling between buildings (L) and visualisation through corner balconies (R).

## Appendix B - Wind Impact Planning Guidelines

It is well known that the design of a building will influence the quality of the ambient wind environment at its base. Below are some suggested wind mitigation strategies that should be adopted into precinct planning guidelines and controls (see also Cochran, 2004).

### Building form – Canopies

A large canopy may interrupt the flow as it moves down the windward face of the building. This will protect the entrances and sidewalk area by deflecting the downwash at the second storey level, Figure B1. However, this approach may have the effect of transferring the breezy conditions to the other side of the street. Large canopies are a common feature near the main entrances of large office buildings.

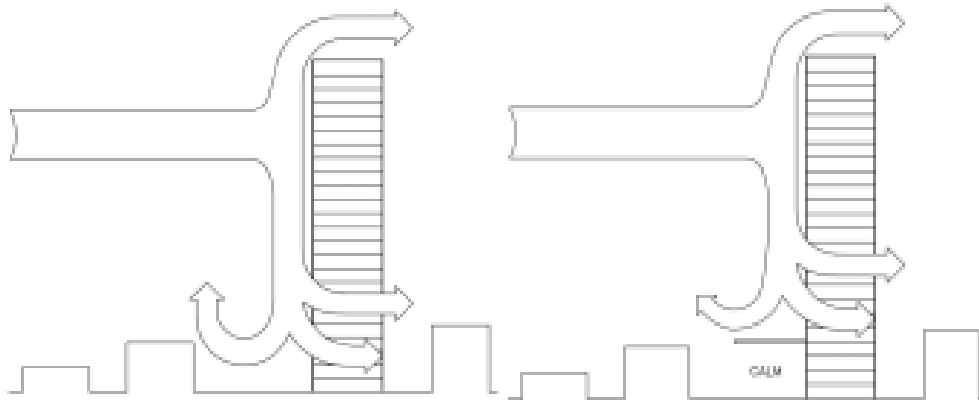

Figure B1: Canopy Windbreak Treatment. (L) Downwash to street level may generate windy conditions for pedestrians. (R) A large canopy is a common solution to this pedestrian-wind problem at street level.

### Building form – Podiums

The architect may elect to use an extensive podium for the same purpose, Figure B2, if it complies with the design mandate. This is a common architectural feature for many major projects, but it may be counterproductive if the architect wishes to use the podium roof for long-term pedestrian activities, such as a pool or tennis court.

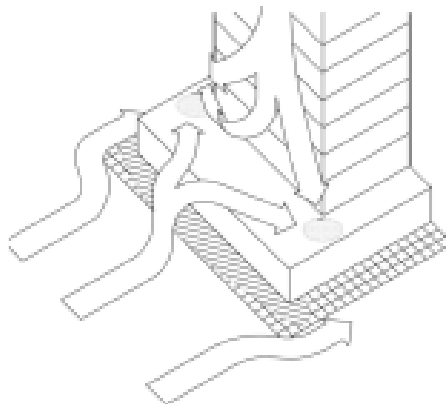

Figure B2: The tower-on-podium massing often results in reasonable conditions at ground level, but the podium may not be useable.

### Building form – Arcades

Another massing issue, which may be a cause of strong ground-level winds, is an arcade or thoroughfare opening from one side of the building to the other. This effectively connects a positive pressure region on the windward side with a negative pressure region on the lee side; a strong flow through the opening often results, Figure B3. The uninvitingly windy nature of these open areas is a contributing reason behind the use of arcade airlock entrances (revolving or double sliding doors).

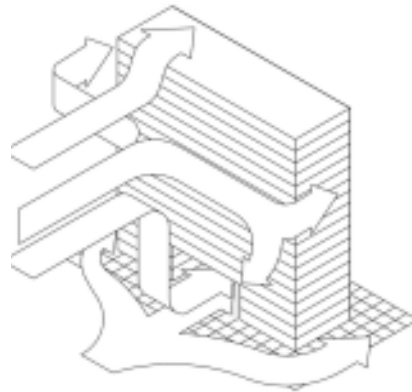

Figure B3: An arcade or open column plaza under a building frequently generates strong pedestrian wind condition.

### Building form – Alcove

An entrance alcove behind the building line will generally produce a calmer entrance area at a mid-building location, Figure B4(L). In some cases, a canopy may not be necessary with this scenario, depending on the local geometry and directional wind characteristics. The same undercut design at a building corner is usually quite unsuccessful, Figure B4 (R), due to the accelerated flow mechanism described in Figure B1 and the ambient directional wind statistics. If there is a strong directional wind preference, and the corner door is shielded from those common stronger winds, then the corner entrance may work. However, it is more common for a corner entrance to be adversely impacted by this local building geometry. The result can range from simply unpleasant conditions to a frequent inability to open the doors.

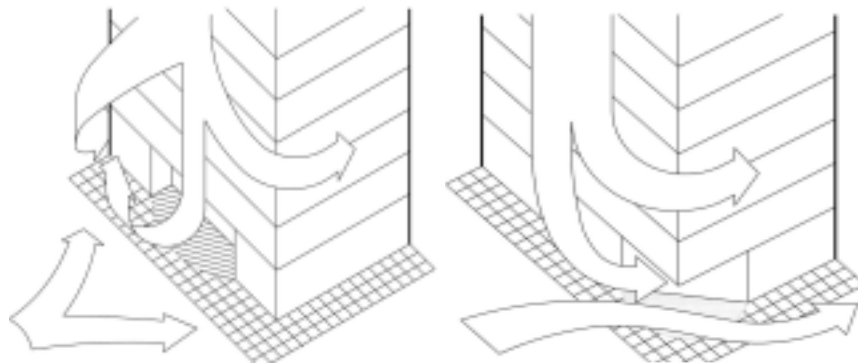

Figure B4: Alcove Windbreak Treatment. (L) A mid-building alcove entrance usually results in an inviting and calm location. (R) Accelerated corner flow from downwash often yields an unpleasant entrance area.

### **Building form – Façade profile and balconies**

The way in which a building's vertical line is broken up may also have an impact. For example, if the floor plans have a decreasing area with increased height the flow down the stepped windward face may be greatly diminished. To a lesser extent the presence of many balconies can have a similar impact on ground level winds, although this is far less certain and more geometry dependent. Apartment designs with many elevated balconies and terrace areas near building ends or corners often attract a windy environment to those locations. Mid-building balconies, on the broad face, are usually a lot calmer, especially if they are recessed. Corner balconies are generally a lot windier and so the owner is likely to be selective about when the balcony is used or endeavours to find a protected portion of the balcony that allows more frequent use, even when the wind is blowing.

### **Use of canopies, trellises, and high canopy foliage**

Downwash Mitigation – As noted earlier, downwash off a tower may be deflected away from ground-level pedestrian areas by large canopies or podium blocks. The downwash then effectively impacts the canopy or podium roof rather than the public areas at the base of the tower, Figure B2. Provided that the podium roof area is not intended for long-term recreational use (e.g. swimming pool or tennis court), this massing method is typically quite successful. However, some large recreational areas may need the wind to be deflected away without blocking the sun (e.g. a pool deck), and so a large canopy is not an option. Downwash deflected over expansive decks like these may often be improved by installing elevated trellis structures or a dense network of trees to create a high, bushy canopy over the long-term recreational areas. Various architecturally acceptable ideas may be explored in the wind tunnel prior to any major financial commitment on the project site.

Horizontally accelerated flows between two tall towers may cause an unpleasant, windy, ground-level pedestrian environment, which could also be locally aggravated by ground topography. Horizontally accelerated flows that create a windy environment are best dealt with by using vertical porous screens or substantial landscaping. Large hedges, bushes or other porous media serve to retard the flow and absorb the energy produced by the wind. A solidity ratio (i.e. proportion of solid area to total area) of about 60-70% has been shown to be most effective in reducing the flow's momentum. These physical changes to the pedestrian areas are most easily evaluated by a model study in a boundary-layer wind tunnel.

### **References**

Cochran L., (2004) Design Features to Change and/or Ameliorate Pedestrian Wind Conditions, Proceedings of the ASCE Structures Congress, Nashville, Tennessee, May 2004.