

NEXTDC S5

SSDA ADDENDUM

SHEET LIST		
DRAWING NUMBER	DRAWING TITLE	REVISION
S5-LAD-ALA-L0000	COVER SHEET	7
S5-LAD-ALA-L0001	LEGEND	7
S5-LAD-ALA-L0002	PLANTING SCHEDULE	7
S5-LAD-ALA-L0101	LANDSCAPE MASTERPLAN	7
S5-LAD-ALA-L0102	LANDSCAPE PLAZA MASTERPLAN	7
S5-LAD-ALA-L0201	GENERAL ARRANGEMENT PLAN 1	7
S5-LAD-ALA-L0202	GENERAL ARRANGEMENT PLAN 2	7
S5-LAD-ALA-L0203	GENERAL ARRANGEMENT PLAN 3	7
S5-LAD-ALA-L0204	GENERAL ARRANGEMENT PLAN 4	7
S5-LAD-ALA-L0205	GENERAL ARRANGEMENT PLAN 5	7
S5-LAD-ALA-L0206	GENERAL ARRANGEMENT PLAN 6	7
S5-LAD-ALA-L0207	GENERAL ARRANGEMENT PLAN 7	7
S5-LAD-ALA-L0208	GENERAL ARRANGEMENT PLAN 8	7
S5-LAD-ALA-L0209	GENERAL ARRANGEMENT PLAN 9	7
S5-LAD-ALA-L0210	GENERAL ARRANGEMENT PLAN 10	7
S5-LAD-ALA-L0401	SOFTWARES PLAN 1	7
S5-LAD-ALA-L0402	SOFTWARES PLAN 2	7
S5-LAD-ALA-L0403	SOFTWARES PLAN 3	7
S5-LAD-ALA-L0404	SOFTWARES PLAN 4	7
S5-LAD-ALA-L0405	SOFTWARES PLAN 5	7
S5-LAD-ALA-L0406	SOFTWARES PLAN 6	7
S5-LAD-ALA-L0407	SOFTWARES PLAN 7	7
S5-LAD-ALA-L0408	SOFTWARES PLAN 8	7
S5-LAD-ALA-L0409	SOFTWARES PLAN 9	7
S5-LAD-ALA-L0410	SOFTWARES PLAN 10	7
S5-LAD-ALA-L0411	BLD O LVL 02, 04, 06, 08 SOFTWARES PLAN 11	7
S5-LAD-ALA-L0601	LANDSCAPE DETAILS	7

DATE	No.	REVISION HISTORY	DRW	CHK	QA
26/09/2025	7	SSDA	MM	MM	
21/09/2025	6	SSDA	MM	MM	
10/09/2025	5	SSDA	SE	MM	
17/09/2025	4	SSDA	SE	MM	
28/09/2024	3	SSDA	SE	MM	
30/09/2024	2	SSDA	SE	MM	
18/09/2024	1	SSDA	SE	MM	

- NOTE:
- ALL DRAWINGS TO BE READ IN CONJUNCTION WITH ASSOCIATED SPECIFICATION
 - DO NOT SCALE FROM DRAWINGS
 - CONFIRM ALL MEASUREMENTS ON SITE
 - CHECK ON SITE PRIOR TO CONSTRUCTION AND REPORT ANY DISCREPANCIES
 - ENSURE COORDINATION WITH OTHER TRADES ON SITE

PRINCIPAL CONSULTANTS

Architect HDR

Services ARUP

Structural TTW

PRINCIPAL CONTRACTOR

Multiplex

CLIENT



N E X T D C

NEXTDC
GPO Box 3219
Brisbane QLD 4001
T: +61 7 3177 4777

ARCHITECT



LANDSCAPE ARCHITECT



ARCADIA

Document Author Project Number

24-1002

Key Plan

Site	Stage	NEXTDC Project Number
S5	REVISED SSDA	S5.00

Project Address

269 LANE COVE ROAD,
MAQUARIE PARK,
SYDNEY, NSW 2113

Project Name

NEXTDC DATA CENTRE

Drawing Title

COVER SHEET

Drawing Status

Development Application

Drawn	Date
PM	26/09/2025
Checked	Date
MM	26/09/2025
Approved	Date
MB	26/09/2025

Scale	Sheet	File Name
A1	SS-LAD-ALA-DRG-0-0101-L0000	

Dwg no.	Rev
SS-LAD-ALA-DRG-0-0101-L0000	7

GENERAL

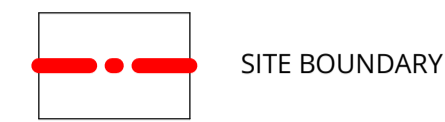

SOFTWORKS

- EXISTING TREES TO BE RETAINED
Refer to Arborist Report for details
- EXISTING TREES TO BE REMOVED
Refer to Arborist Report for details
- PROPOSED TREES
Refer Landscape

PLANTING MIXES

- PROPOSED TURF
Refer Plant Schedule
- WSUD SWALE MATRIX
Refer Plant Schedule
- SHADE MATRIX
Refer Plant Schedule
- MODERATE SUN MATRIX
Refer Plant Schedule
- FULL SUN MATRIX
Refer Plant Schedule
- NATIVE GRASS MATRIX
Refer Plant Schedule
- STREETSCAPE MATRIX
Refer Plant Schedule

DATE	No.	REVISION HISTORY	DRW	CHK	QA
26/09/2025	7	SSDA	PM	MM	
31/03/2025	6	SSDA	MM	MM	
10/03/2025	5	SSDA	SE	MM	
11/02/2025	4	SSDA	SE	MM	
28/10/2024	3	SSDA	SE	MM	
30/05/2024	2	SSDA	SE	MM	
18/04/2024	1	SSDA	SE	MM	

NOTE:

- ALL DRAWINGS TO BE READ IN CONJUNCTION WITH ASSOCIATED SPECIFICATION
- DO NOT SCALE FROM DRAWINGS
- CONFIRM ALL MEASUREMENTS ON SITE
- CHECK ON SITE PRIOR TO CONSTRUCTION AND REPORT ANY DISCREPANCIES
- ENSURE COORDINATION WITH OTHER TRADES ON SITE

PRINCIPAL CONSULTANTS

Architect HDR

Services ARUP

Structural TTW

PRINCIPAL CONTRACTOR
Multiplex

CLIENT

NEXTDC
GPO Box 3219
Brisbane QLD 4001
T: +61 7 3177 4777

ARCHITECT

LANDSCAPE ARCHITECT

Document Author Project Number
24-1002

Key Plan

Site	Stage	NEXTDC Project Number
S5	REVISED SSDA	S5.00

Project Address
**269 LANE COVE ROAD,
MAQUARIE PARK,
SYDNEY, NSW 2113**

Project Name
NEXTDC DATA CENTRE

Drawing Title
LEGEND

Drawing Status
Development Application

Drawn	Date
PM	26/09/2025
Checked	Date
SE	26/09/2025
Approved	Date
MB	26/09/2025

Scale	Sheet	File Name
1 : 50	A1	SS-LAD-ALA-DRG-0-0101-L0001
Dwg no:	Rev	
SS-LAD-ALA-DRG-0-0101-L0001	7	

PROPOSED TREE SCHEDULE					
CODE	BOTANICAL NAME	COMMON NAME	MATURE SIZE	POT SIZE	QTY
Ac	Angophora costata	Smooth Apple Bark	18 x 12	100L	9
Ac	Angophora costata	Smooth Apple Bark	18 x 12	200L	12
Af	Angophora floribunda	Rough-Barked Apple	10 x 8	100L	2
Af	Angophora floribunda	Rough-Barked Apple	10 x 8	200L	1
Ahd	Angophora hispida	Dwarf Apple Gum	7 x 5	200L	6
Cm	Corymbia maculata	Spotted Gum	15 x 12	100L	5
Cm	Corymbia maculata	Spotted Gum	15 x 12	200L	1
ELS	Eucalyptus mannifera	Dwarf Red Spotted Gum	5 x 5	200L	58
Ep	Eucalyptus piperita	Sydney Peppermint	18 x 11	100L	11
Er	Eucalyptus resinifera	Red Mahogany	25 x 10	100L	4
EDG	Eucalyptus 'Euky Dwarf Gum'	Dwarf Yellow Gum	5 x 3	200L	9
TLL	Angophora costata	Smooth Apple Bark	18 x 12	100L	3
TLL	Angophora costata	Smooth Apple Bark	18 x 12	200L	18

TOTAL NUMBER OF PROPOSED TREES: 139

GROUND COVERS

Code	Botanical Name	Common Name	Mature Size	Post Size	Qty
Dlj	Dianella caerulea 'Little Jess'	Flax lily	0.4 x 0.4	150mm	65
Gj	Grevillea Juniperina	Gold Cluster	0.3 x 0.8	150mm	865
Ta	Themeda australis	Kangaroo Grass	1 x 0.5	150mm	596
Wf	Westringia Low Horizon	Westringia	0.3 x 0.7	150mm	274

TURF

Code	Name	Area
TF-101	Proposed Lawn	2891m2

MT-101 SWALE

Code	Botanical Name	Common Name	Mature Size	Post Size	Qty
Ca	Carex appressa	Carex appressa	1.5 x 1.5	150mm	150
Gf	Gahnia filum	Chaffy Saw-sedge	1.5 x 1.5	150mm	150
Leb	Lomandra labill 'Evergreen Baby'	Evergreen Baby	0.45 x 0.45	150mm	150

MT-102 SHADE

Code	Botanical Name	Common Name	Mature Size	Post Size	Qty
Bc	Blechnum cartilagineum	Soft Water Fern	1 x 1	150mm	396
Lm	Liriope muscari	Lily Turf	0.4 x 0.4	150mm	396
Bn	Blechnum nudum	Fishbone Fern	0.8 x 0.8	150mm	396
Aa	Adiantum aethiopicum	Madien Hair Fern	0.4 x 0.5	150mm	396

MT-103 MODERATE SUN

Code	Botanical Name	Common Name	Mature Size	Post Size	Qty
Ll	Lomandra longifolia	Spiky mat rush	1 x 1	150mm	167
Pl	Poa labillardieri	Tussock Grass	0.6 x 0.6	150mm	167
Ta	Themeda australis	Kangaroo Grass	1 x 0.5	150mm	167
Ac	Austrodanthonia caespitosa	Wallaby Grass	0.8 0.3	150mm	167
Lm	Liriope muscari	Lily Turf	0.4 x 0.4	150mm	222
Ca	Carex appressa	Tall Sedge	1.5 x 1.5	150mm	149

MT-104 FULLE SUN MATRIX

Code	Botanical Name	Common Name	Mature Size	Post Size	Qty
Lt	Lomandra Tankia	Lomandra Tankia	0.7 x 0.7	150mm	799
Pl	Poa labillardieri	Tussock Grass	0.6 x 0.6	150mm	799
Ta	Themeda australis	Kangaroo Grass	1 x 0.5	150mm	799
Pn	Pennisetum 'Nafray'	Foxtail Grass	0.6 X 0.6	150mm	799
Ac	Austrodanthonia caespitosa	Wallaby Grass	0.8 0.3	150mm	799

MT-105 NATIVE GRASS MATRIX

Code	Botanical Name	Common Name	Mature Size	Post Size	Qty
Ta	Themeda australis	Kangaroo Grass	1 x 0.5	150mm	370
Pn	Pennisetum 'Nafray'	Foxtail Grass	0.6 X 0.6	150mm	370
Pl	Poa labillardieri	Tussock Grass	0.6 x 0.6	150mm	370

MT-106 STREET SCAPE MATRIX

Code	Botanical Name	Common Name	Mature Size	Post Size	Qty
Lt	Lomandra Tankia	Lomandra Tankia	0.7 x 0.7	150mm	915
Dc	Dianella caerulea	Blue Flax Lily	0.4 x 0.4	150mm	915
Wg	Wahlenbergia gracilis	Australian Blue Bell	0.3 x 0.8	150mm	915
Ca	Carex appressa	Tall Sedge	1.5 x 1.5	150mm	915

DATE	No.	REVISION HISTORY	DRW	CHK	QA
26/09/2025	7	SSDA	PM	MM	
21/09/2025	6	SSDA	MM	MM	
10/09/2025	5	SSDA	SE	MM	
11/09/2025	4	SSDA	SE	MM	
28/09/2024	3	SSDA	SE	MM	
30/09/2024	2	SSDA	SE	MM	
18/09/2024	1	SSDA	SE	MM	

NOTE:

- ALL DRAWINGS TO BE READ IN CONJUNCTION WITH ASSOCIATED SPECIFICATION
- DO NOT SCALE FROM DRAWINGS
- CONFIRM ALL MEASUREMENTS ON SITE
- CHECK ON SITE PRIOR TO CONSTRUCTION AND REPORT ANY DISCREPANCIES
- ENSURE COORDINATION WITH OTHER TRADES ON SITE

PRINCIPAL CONSULTANTS

Architect HDR

Services ARUP

Structural TTW

PRINCIPAL CONTRACTOR

Multiplex

CLIENT



NEXTDC

NEXTDC
GPO Box 3219
Brisbane QLD 4001
T: +61 7 3177 4777

ARCHITECT



LANDSCAPE ARCHITECT

ARCADIA

Document Author Project Number

24-1002

Key Plan

Site	Stage	NEXTDC Project Number
S5	REVISED SSDA	S5.00

Project Address

269 LANE COVE ROAD,
MAQUARIE PARK,
SYDNEY, NSW 2113

Project Name

NEXTDC DATA CENTRE

Drawing Title

PLANTING SCHEDULE

Drawing Status

Development Application

Drawn	Date
PM	26/09/2025

Checked	Date
MB	26/09/2025

Approved	Date
MB	26/09/2025

Scale	Sheet	File Name
A1	SS-LAD-ALA-DRG-0-0101-L0002	

Dwg no.	Rev
SS-LAD-ALA-DRG-0-0101-L0002	7

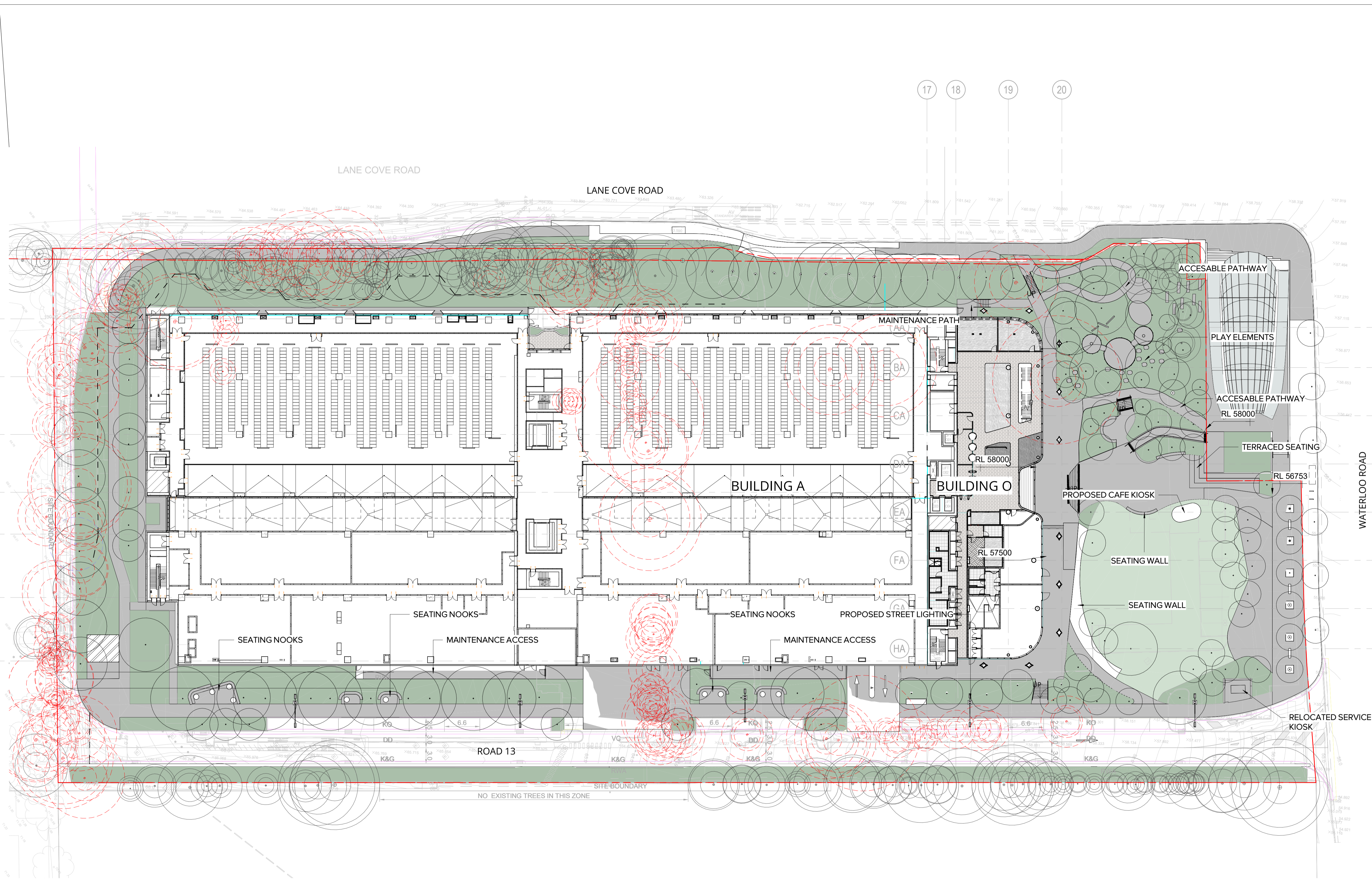

DATE	No.	REVISION HISTORY	DRW	CHK	QA
26/09/2025	7	SSDA	PM	MM	
21/09/2025	6	SSDA	MM	MM	
10/09/2025	5	SSDA	SE	MM	
11/09/2025	4	SSDA	SE	MM	
28/09/2024	3	SSDA	SE	MM	
30/09/2024	2	SSDA	SE	MM	
18/04/2024	1	SSDA	SE	MM	

NOTE:
 1. ALL DRAWINGS TO BE READ IN CONJUNCTION WITH ASSOCIATED SPECIFICATION
 2. DO NOT SCALE FROM DRAWINGS
 3. CONFIRM ALL MEASUREMENTS ON SITE
 4. CHECK ON SITE PRIOR TO CONSTRUCTION AND REPORT ANY DISCREPANCIES
 5. ENSURE COORDINATION WITH OTHER TRADES ON SITE

PRINCIPAL CONSULTANTS
 Architect HDR
 Services ARUP
 Structural TTW
 PRINCIPAL CONTRACTOR
Multiplex
 CLIENT

NEXTDC
 NEXTDC
 GPO Box 3219
 Brisbane QLD 4001
 T: +61 7 3177 4777
 ARCHITECT

HDR
 LANDSCAPE ARCHITECT

ARCADIA

Document Author Project Number
 24-1002

Key Plan

Site	Stage	NEXTDC Project Number
S5	REVISED SSDA	S5.00

Project Address
**269 LANE COVE ROAD,
 MAQUARIE PARK,
 SYDNEY, NSW 2113**

Project Name
NEXTDC DATA CENTRE

Drawing Title
**LANDSCAPE
 MASTERPLAN**

Drawing Status
Development Application

Drawn	PM	Date	26/09/2025
Checked	SE	Date	26/09/2025
Approved	MB	Date	26/09/2025

Scale	Sheet	File Name
1 : 350	A1	SS-LAD-ALA-DRG-0-0101-L0101
Dwg no:		Rev
SS-LAD-ALA-DRG-0-0101-L0101		7

DATE	No.	REVISION HISTORY	DRW	CHK	QA
26/09/2025	7	SSDA	PM	MM	
21/03/2025	6	SSDA	MM	MM	
10/03/2025	5	SSDA	SE	MM	
11/02/2025	4	SSDA	SE	MM	
28/10/2024	3	SSDA	SE	MM	
30/05/2024	2	SSDA	SE	MM	
18/02/2024	1	SSDA	SE	MM	

- NOTE:
- ALL DRAWINGS TO BE READ IN CONJUNCTION WITH ASSOCIATED SPECIFICATION
 - DO NOT SCALE FROM DRAWINGS
 - CONFIRM ALL MEASUREMENTS ON SITE
 - CHECK ON SITE PRIOR TO CONSTRUCTION AND REPORT ANY DISCREPANCIES
 - ENSURE COORDINATION WITH OTHER TRADES ON SITE

PRINCIPAL CONSULTANTS

Architect HDR
Services ARUP
Structural TTW

PRINCIPAL CONTRACTOR
Multiplex

CLIENT



NEXTDC

NEXTDC
GPO Box 3219
Brisbane QLD 4001
T: +61 7 3177 4777

ARCHITECT



LANDSCAPE ARCHITECT

ARCADIA

Document Author Project Number
24-1002

Key Plan



Site	Stage	REVISID	NEXTDC Project Number
S5	REVISED	SSDA	S5.00

Project Address
**269 LANE COVE ROAD,
MAQUARIE PARK,
SYDNEY, NSW 2113**

Project Name
NEXTDC DATA CENTRE

Drawing Title
**LANDSCAPE PLAZA
MASTERPLAN**

Drawing Status
Development Application

Drawn	PM	Date
PM	26/09/2025	
Checked	SE	Date
SE	26/09/2025	
Approved	MB	Date
MB	26/09/2025	

Scale	Sheet	File Name
1:200	A1	SS-LAD-ALA-DRG-0-0101-L0102
Dwg no.	Rev	
SS-LAD-ALA-DRG-0-0101-L0102	7	

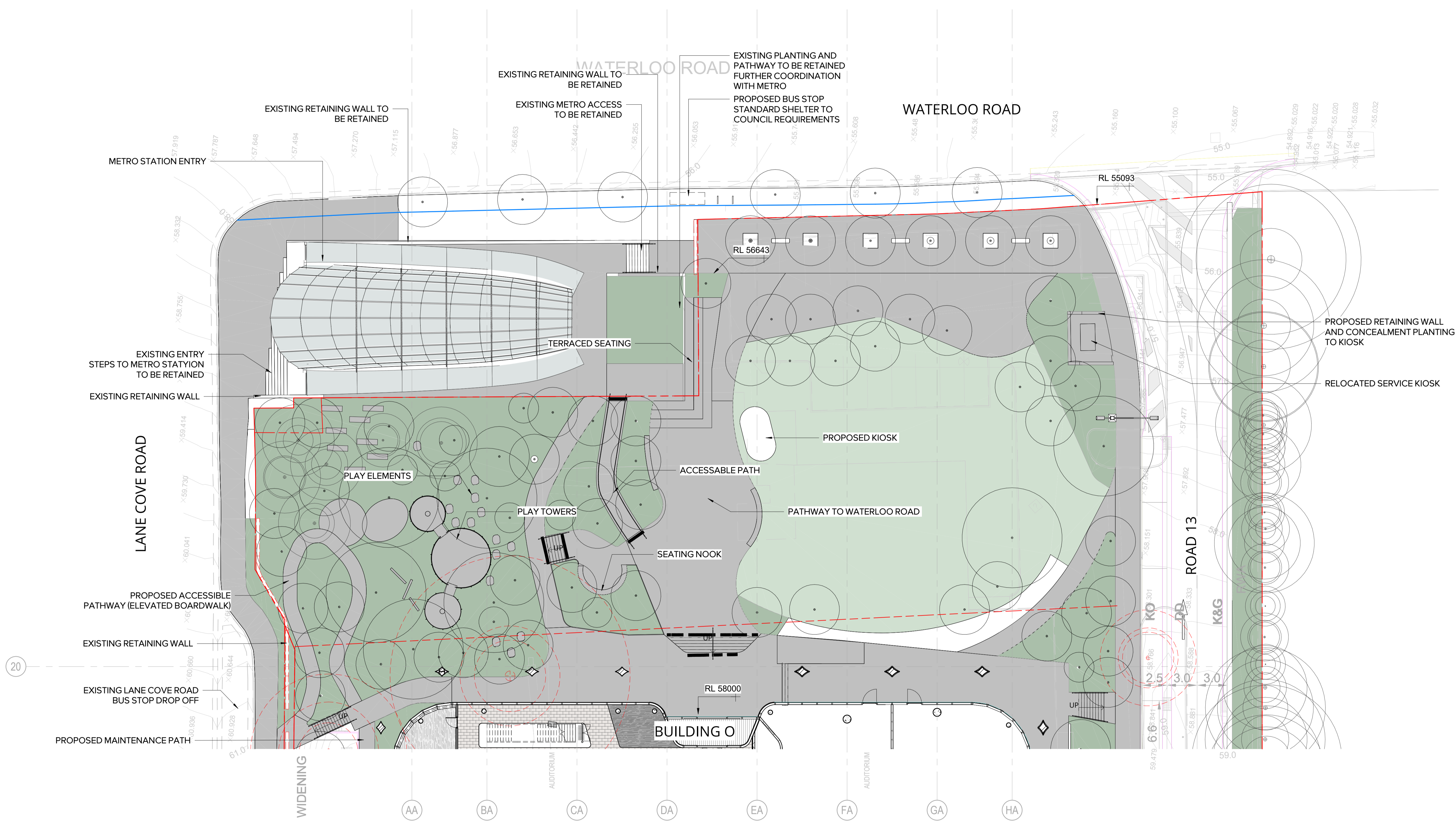

Arcadia Docs\110716471_NEXTDC_S5ABG_2102\SS-LAD-ALA-DRG-0-0101-L0102.dwg

26/09/2025 2:45:37 PM

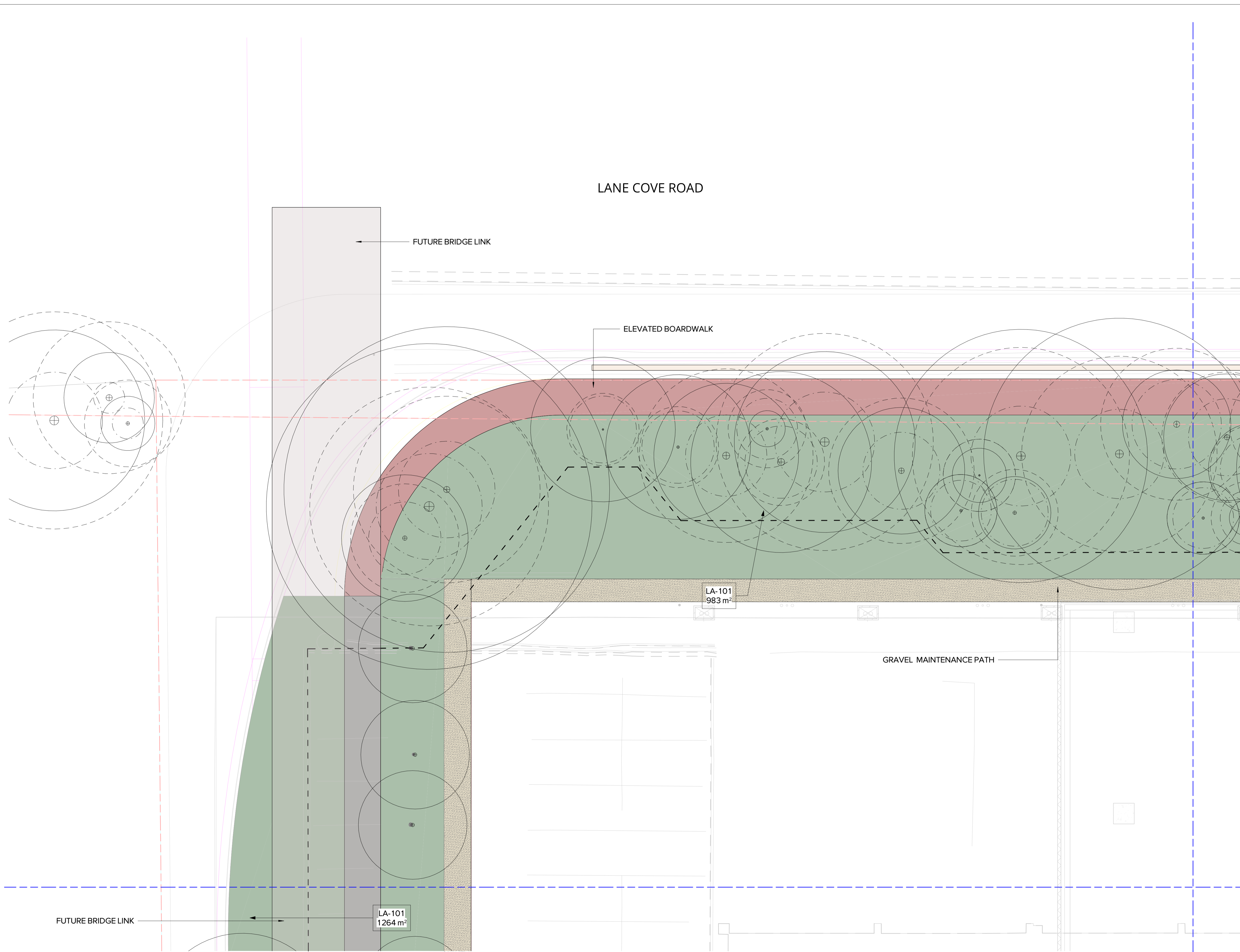

DATE	No.	REVISION HISTORY	DRW	CHK	QA
26/09/2025	7	SSDA	PM	MM	
31/03/2025	6	SSDA	MM	MM	
10/03/2025	5	SSDA	SE	MM	
11/02/2025	4	SSDA	SE	MM	
28/10/2024	3	SSDA	SE	MM	
30/05/2024	2	SSDA	SE	MM	
18/04/2024	1	SSDA	SE	MM	

- NOTE:
1. ALL DRAWINGS TO BE READ IN CONJUNCTION WITH ASSOCIATED SPECIFICATION
 2. DO NOT SCALE FROM DRAWINGS
 3. CONFIRM ALL MEASUREMENTS ON SITE
 4. CHECK ON SITE PRIOR TO CONSTRUCTION AND REPORT ANY DISCREPANCIES
 5. ENSURE COORDINATION WITH OTHER TRADES ON SITE

PRINCIPAL CONSULTANTS

Architect HDR
 Services ARUP
 Structural TTW

PRINCIPAL CONTRACTOR
Multiplex

CLIENT



NEXTDC

NEXTDC
 GPO Box 3219
 Brisbane QLD 4001
 T: +61 7 3177 4777

ARCHITECT



LANDSCAPE ARCHITECT



Document Author Project Number
 24-1002

Key Plan



Site	Stage	NEXTDC Project Number
S5	REVISED SSDA	S5.00

Project Address
 269 LANE COVE ROAD,
 MAQUARIE PARK,
 SYDNEY, NSW 2113

Project Name
 NEXTDC DATA CENTRE

Drawing Title
 GENERAL
 ARRANGEMENT PLAN 1

Drawing Status
 Development Application

Drawn	Date
PM	26/09/2025
Checked	Date
SE	26/09/2025
Approved	Date
MB	26/09/2025

Scale	Sheet	File Name
1 : 100	A1	SS-LAD-ALA-DRG-0-0101-L0201
Dwg no:	Rev	
SS-LAD-ALA-DRG-0-0101-L0201	7	

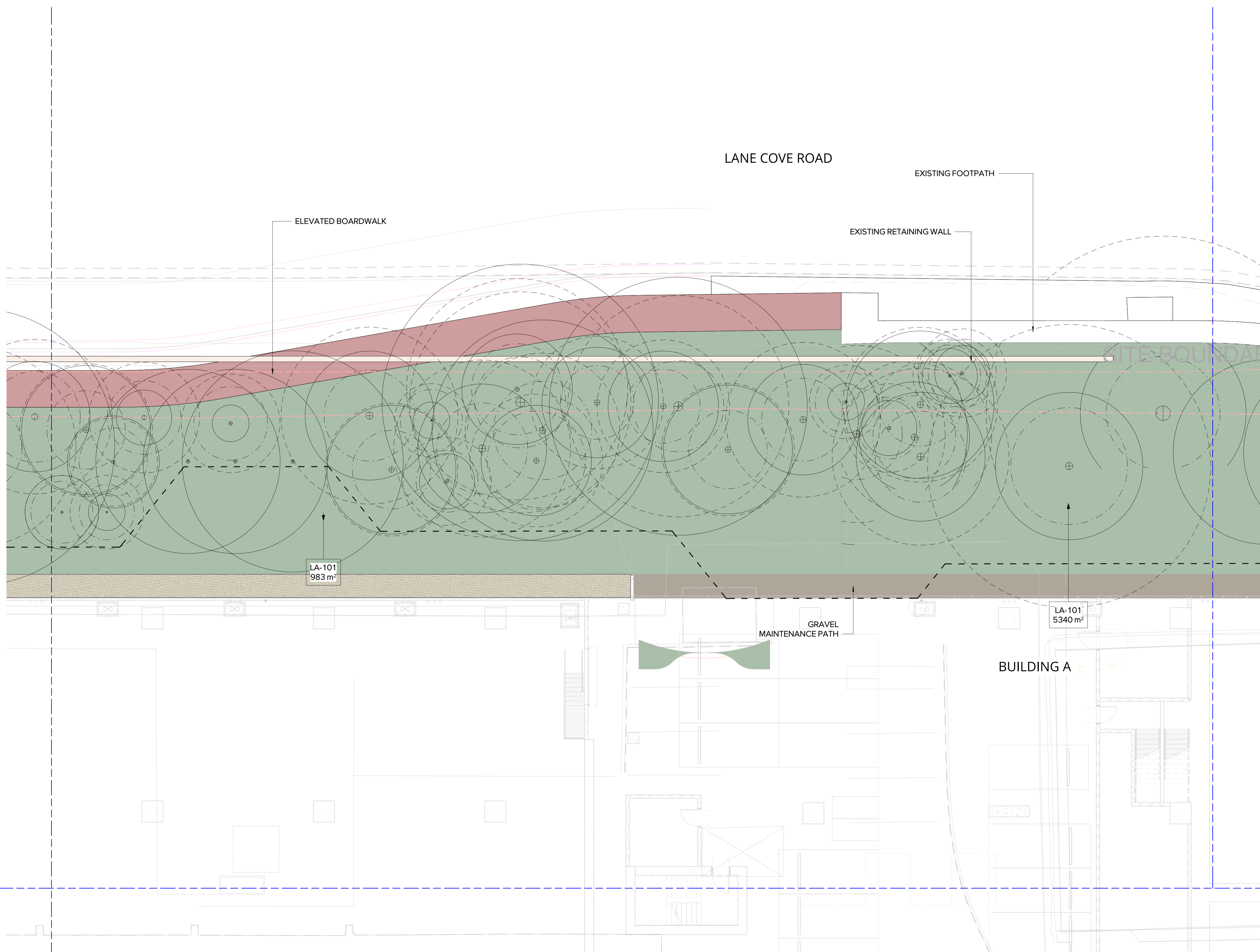

DATE	No.	REVISION HISTORY	DRW	CHK	QA
26/09/2025	7	SSDA	PM	MM	
21/09/2025	6	SSDA	MM	MM	
10/09/2025	5	SSDA	SE	MM	
11/09/2025	4	SSDA	SE	MM	
28/09/2024	3	SSDA	SE	MM	
30/09/2024	2	SSDA	SE	MM	
18/04/2024	1	SSDA	SE	MM	

NOTE:
 1. ALL DRAWINGS TO BE READ IN CONJUNCTION WITH ASSOCIATED SPECIFICATION
 2. DO NOT SCALE FROM DRAWINGS
 3. CONFIRM ALL MEASUREMENTS ON SITE
 4. CHECK ON SITE PRIOR TO CONSTRUCTION AND REPORT ANY DISCREPANCIES
 5. ENSURE COORDINATION WITH OTHER TRADES ON SITE

PRINCIPAL CONSULTANTS
 Architect HDR
 Services ARUP
 Structural TTW

PRINCIPAL CONTRACTOR
Multiplex

CLIENT



NEXTDC
 NEXTDC
 GPO Box 3219
 Brisbane QLD 4001
 T: +61 7 3177 4777

ARCHITECT

LANDSCAPE ARCHITECT

Document Author Project Number
 24-1002
 Key Plan

Site	Stage	NEXTDC Project Number
S5	REVISED SSDA	S5.00

Project Address
 269 LANE COVE ROAD,
 MAQUARIE PARK,
 SYDNEY, NSW 2113

Project Name
 NEXTDC DATA CENTRE

Drawing Title
 GENERAL
 ARRANGEMENT PLAN 2

Drawing Status
 Development Application

Drawn	PM	Date
SE	MM	26/09/2025
Checked	SE	Date
SE	MM	26/09/2025
Approved	MB	Date
MM	MM	26/09/2025

Scale	Sheet	File Name
1 : 100	A1	SS-LAD-ALA-DRG-0-0101-L0202
Dwg no:	Rev	
SS-LAD-ALA-DRG-0-0101-L0202	7	

LANE COVE ROAD

SITE BOUNDARY

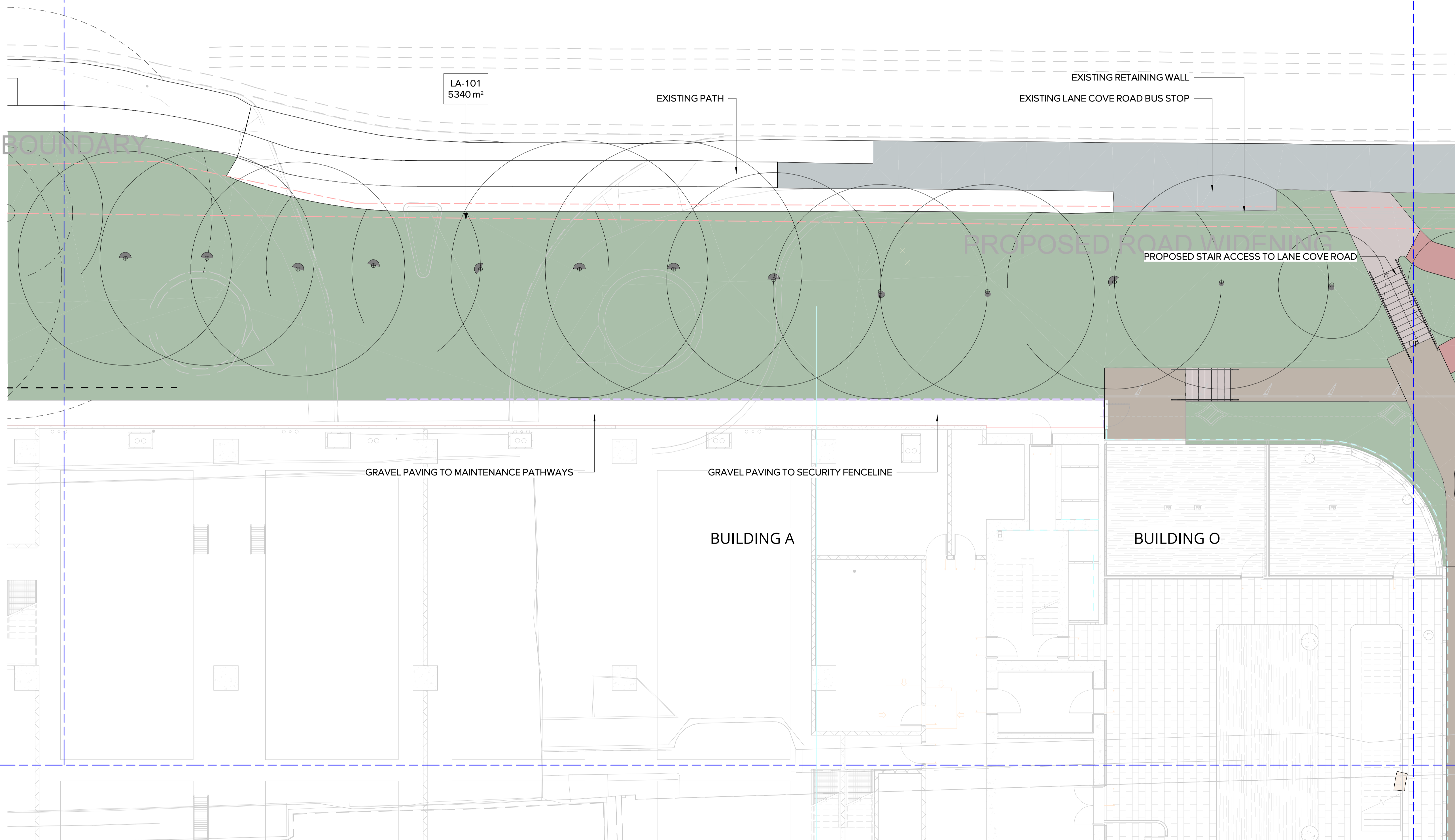

DATE	No.	REVISION HISTORY	DRW	CHK	QA
26/09/2025	7	SSDA	MM		
31/03/2025	6	SSDA	MM		
10/03/2025	5	SE	MM		
11/02/2025	4	SSDA	SE		
28/10/2024	3	SSDA	SE		
30/05/2024	2	SSDA	SE		
18/04/2024	1	SSDA	MM		

- NOTE:
- ALL DRAWINGS TO BE READ IN CONJUNCTION WITH ASSOCIATED SPECIFICATION
 - DO NOT SCALE FROM DRAWINGS
 - CONFIRM ALL MEASUREMENTS ON SITE
 - CHECK ON SITE PRIOR TO CONSTRUCTION AND REPORT ANY DISCREPANCIES
 - ENSURE COORDINATION WITH OTHER TRADES ON SITE

PRINCIPAL CONSULTANTS

Architect HDR
 Services ARUP
 Structural TTW

PRINCIPAL CONTRACTOR
Multiplex

CLIENT

NEXTDC
 GPO Box 3219
 Brisbane QLD 4001
 T: +61 7 3177 4777

ARCHITECT

LANDSCAPE ARCHITECT

Document Author Project Number
 24-1002

Key Plan

Site	Stage	NEXTDC Project Number
S5	REVISED SSDA	S5.00

Project Address
 269 LANE COVE ROAD,
 MAQUARIE PARK,
 SYDNEY, NSW 2113

Project Name
 NEXTDC DATA CENTRE

Drawing Title
 GENERAL
 ARRANGEMENT PLAN 3

Drawing Status
 Development Application

Drawn	SE	Date
MB	SE	26/09/2025

Scale	Sheet	File Name
1 : 100	A1	SS-LAD-ALA-DRG-0-0101-L0203

Dwg no:	Rev
SS-LAD-ALA-DRG-0-0101-L0203	7

ENING

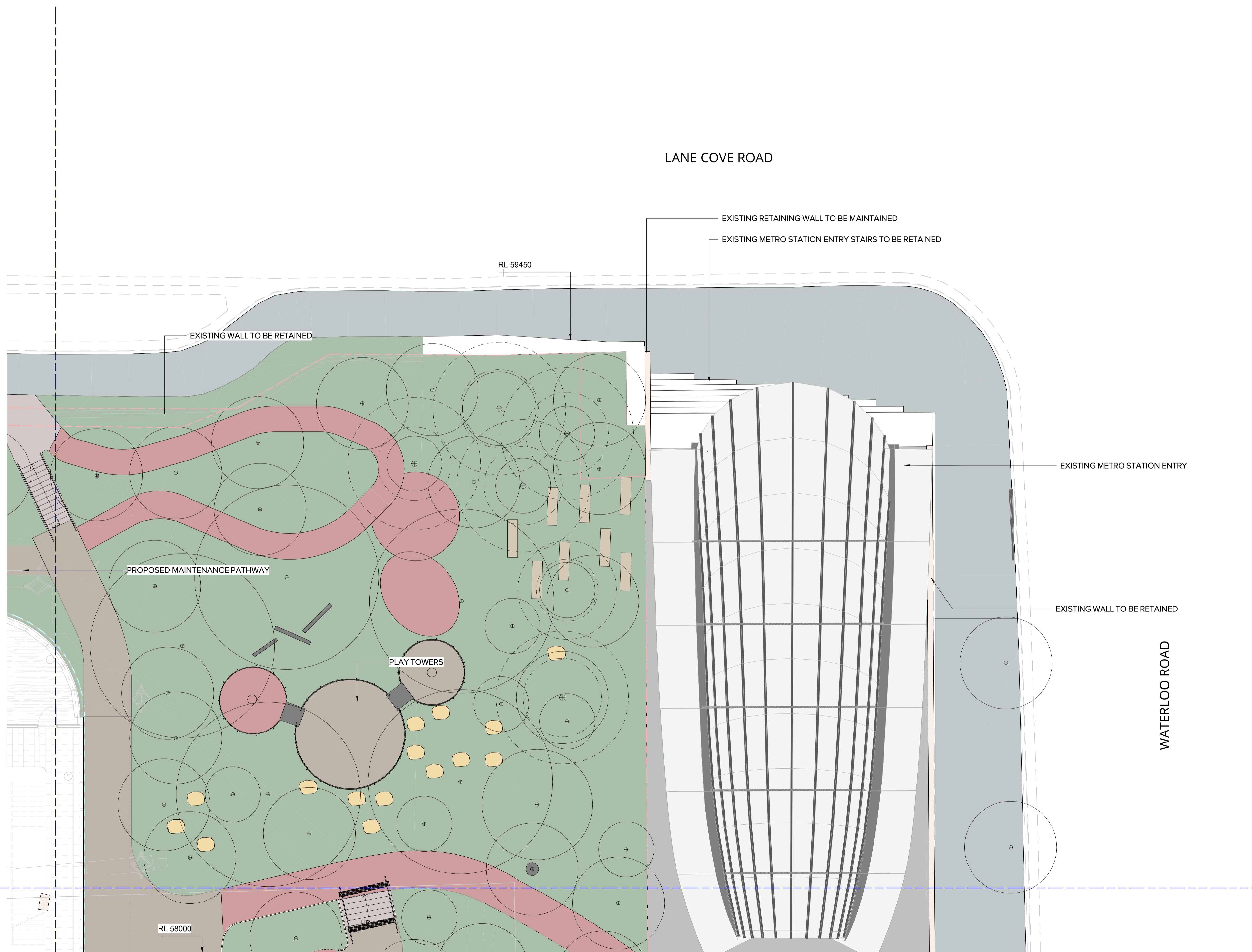

LANE COVE ROAD

EXISTING RETAINING WALL TO BE MAINTAINED

EXISTING METRO STATION ENTRY STAIRS TO BE RETAINED

RL 59450

EXISTING WALL TO BE RETAINED

PROPOSED MAINTENANCE PATHWAY

PLAY TOWERS

EXISTING METRO STATION ENTRY

EXISTING WALL TO BE RETAINED

WATERLOO ROAD

RL 58000

DATE	No.	REVISION HISTORY	DRW	CHK	QA
26/09/2025	7	SSDA	PM	MM	
31/03/2025	6	SSDA	MM	MM	
10/03/2025	5	SSDA	SE	MM	
11/02/2025	4	SSDA	SE	MM	
28/10/2024	3	SSDA	SE	MM	
30/09/2024	2	SSDA	SE	MM	
18/04/2024	1	SSDA	SE	MM	

- NOTE:
1. ALL DRAWINGS TO BE READ IN CONJUNCTION WITH ASSOCIATED SPECIFICATION
 2. DO NOT SCALE FROM DRAWINGS
 3. CONFIRM ALL MEASUREMENTS ON SITE
 4. CHECK ON SITE PRIOR TO CONSTRUCTION AND REPORT ANY DISCREPANCIES
 5. ENSURE COORDINATION WITH OTHER TRADES ON SITE

PRINCIPAL CONSULTANTS

Architect HDR

Services ARUP

Structural TTW

PRINCIPAL CONTRACTOR

Multiplex

CLIENT



NEXTDC

NEXTDC
GPO Box 3219
Brisbane QLD 4001
T: +61 7 3177 4777

ARCHITECT



LANDSCAPE ARCHITECT

ARCADIA

Document Author Project Number

24-1002

Key Plan



Site	Stage	NEXTDC Project Number
S5	REVISED SSDA	S5.00

Project Address

269 LANE COVE ROAD,
MAQUARIE PARK,
SYDNEY, NSW 2113

Project Name

NEXTDC DATA CENTRE

Drawing Title

GENERAL
ARRANGEMENT PLAN 4

Drawing Status

Development Application

Drawn	Date
PM	26/09/2025
Checked	Date
SE	26/09/2025
Approved	Date
MB	26/09/2025

Scale	Sheet	File Name
1 : 100	A1	SS-LAD-ALA-DRG-0-0101-L0204
Dwg no:	Rev	
SS-LAD-ALA-DRG-0-0101-L0204	7	

26/09/2025 2:46:34 PM

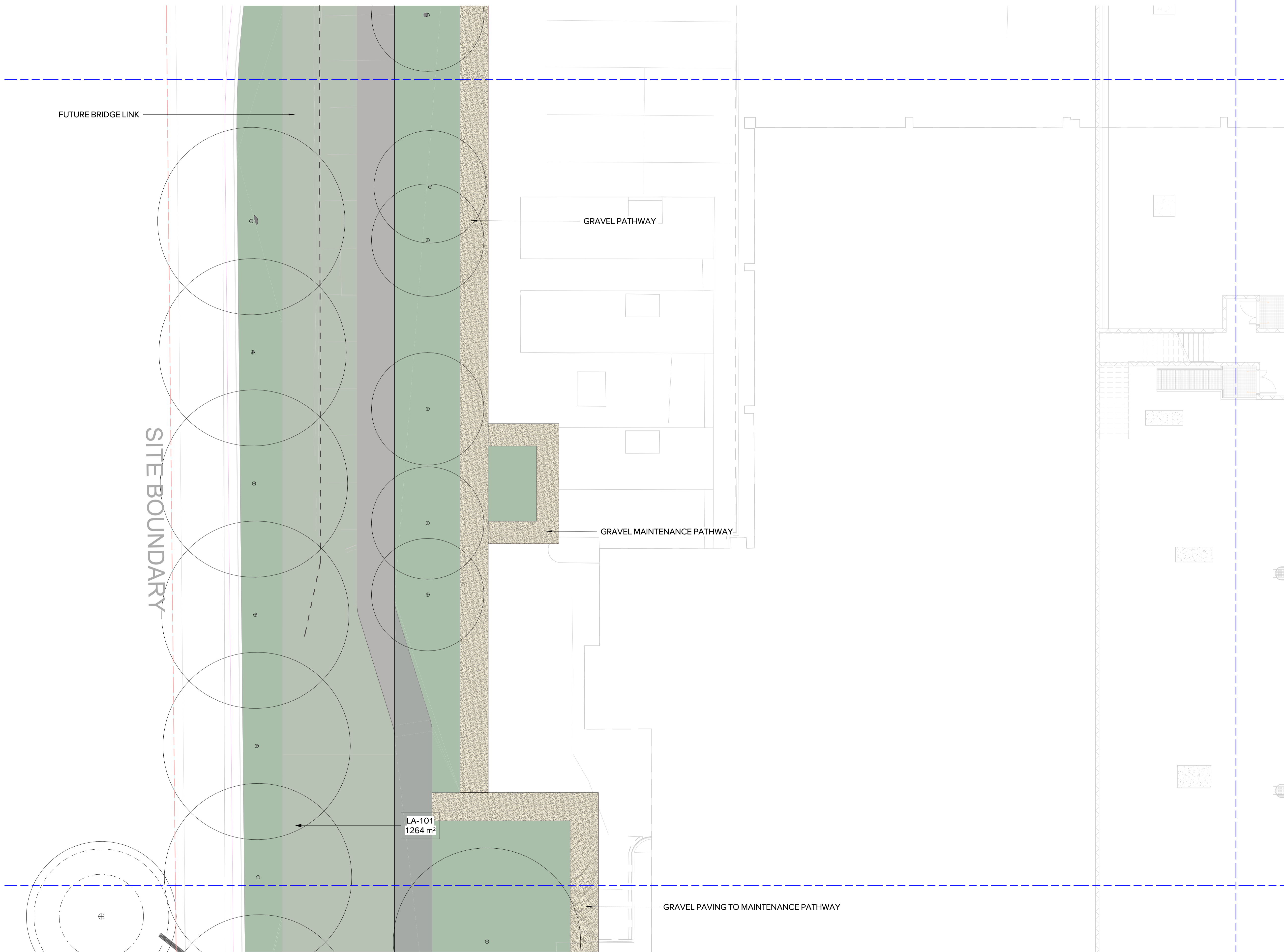

DATE	No.	REVISION HISTORY	DRW	CHK	QA
26/09/2025	7	SSDA	PM	MM	
21/09/2025	6	SSDA	MM	MM	
10/03/2025	5	SSDA	SE	MM	
17/02/2025	4	SSDA	SE	MM	
28/02/2024	3	SSDA	SE	MM	
30/05/2024	2	SSDA	SE	MM	
18/04/2024	1	SSDA	SE	MM	

- NOTE:
1. ALL DRAWINGS TO BE READ IN CONJUNCTION WITH ASSOCIATED SPECIFICATION
 2. DO NOT SCALE FROM DRAWINGS
 3. CONFIRM ALL MEASUREMENTS ON SITE
 4. CHECK ON SITE PRIOR TO CONSTRUCTION AND REPORT ANY DISCREPANCIES
 5. ENSURE COORDINATION WITH OTHER TRADES ON SITE

PRINCIPAL CONSULTANTS

Architect HDR
 Services ARUP
 Structural TTW

PRINCIPAL CONTRACTOR
Multiplex

CLIENT



NEXTDC

NEXTDC
 GPO Box 3219
 Brisbane QLD 4001
 T: +61 7 3177 4777

ARCHITECT



LANDSCAPE ARCHITECT



Document Author Project Number
 24-1002

Key Plan



Site	Stage	NEXTDC Project Number
S5	REVISED SSDA	S5.00

Project Address
 269 LANE COVE ROAD,
 MAQUARIE PARK,
 SYDNEY, NSW 2113

Project Name
 NEXTDC DATA CENTRE

Drawing Title
 GENERAL
 ARRANGEMENT PLAN 5

Drawing Status
 Development Application

Drawn	PM	Date	26/09/2025
Checked	SE	Date	26/09/2025
Approved	MB	Date	26/09/2025

Scale	Sheet	File Name
1 : 100	A1	SS-LAD-ALA-DRG-0-0101-L0205
Dwg no:		Rev
SS-LAD-ALA-DRG-0-0101-L0205		7

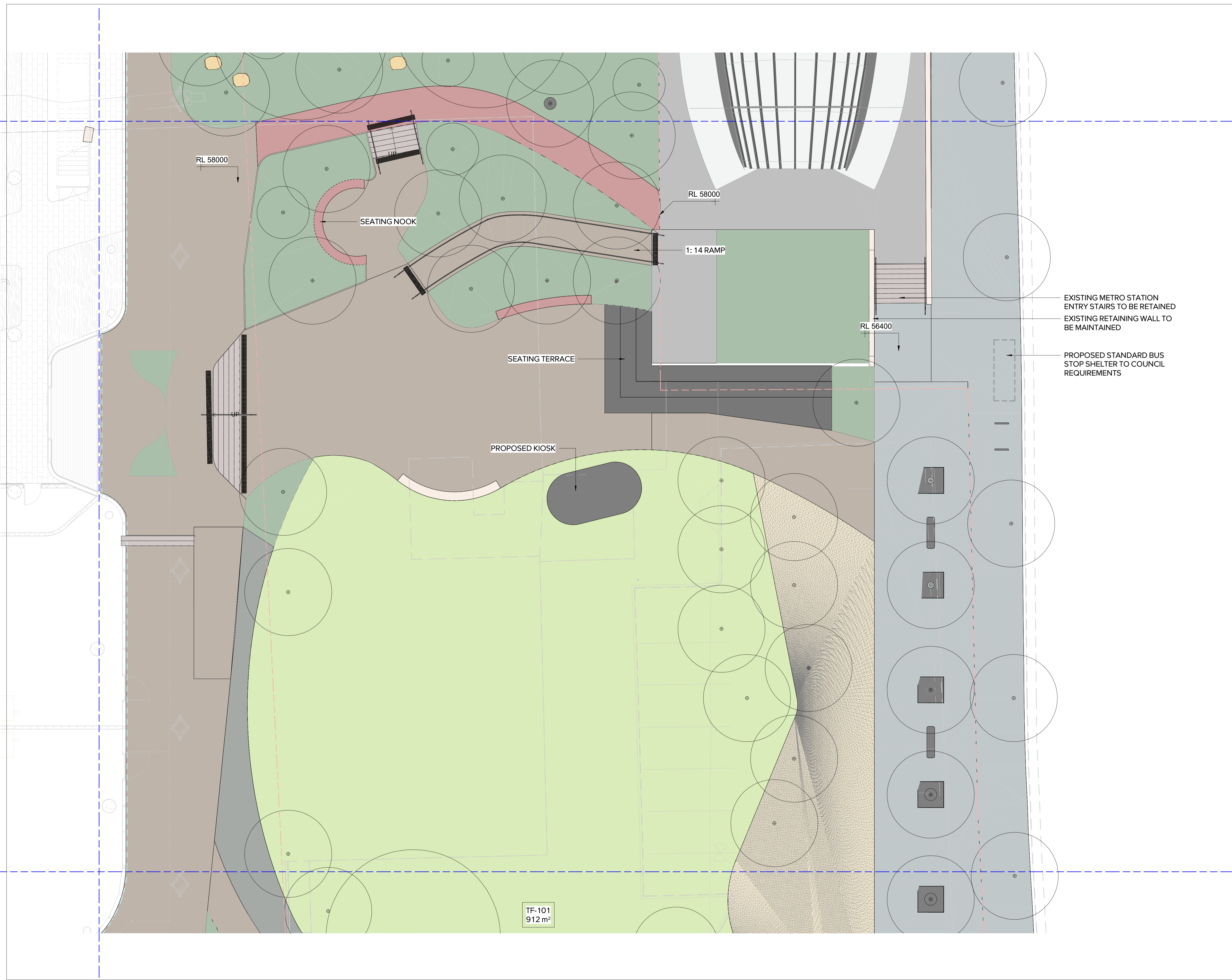

DATE	No.	REVISION HISTORY	DRW	CHK	QA
26/09/2025	7	SSDA	PM	MM	MM
21/09/2025	6	SSDA	MM	MM	MM
10/09/2025	5	SSDA	SE	MM	MM
11/09/2025	4	SSDA	SE	MM	MM
28/09/2024	3	SSDA	SE	MM	MM
30/09/2024	2	SSDA	SE	MM	MM
18/04/2024	1	SSDA	SE	MM	MM

NOTE:

- ALL DRAWINGS TO BE READ IN CONJUNCTION WITH ASSOCIATED SPECIFICATION
- DO NOT SCALE FROM DRAWINGS
- CONFIRM ALL MEASUREMENTS ON SITE
- CHECK ON SITE PRIOR TO CONSTRUCTION AND REPORT ANY DISCREPANCIES
- ENSURE COORDINATION WITH OTHER TRADES ON SITE

PRINCIPAL CONSULTANTS

Architect HDR

Services ARUP

Structural TTW

PRINCIPAL CONTRACTOR
Multiplex

CLIENT



NEXTDC

NEXTDC
GPO Box 5219
Brisbane QLD 4001
T: +61 7 3177 4777

ARCHITECT



LANDSCAPE ARCHITECT



Document Author Project Number
24-1002



Site	Stage	NEXTDC Project Number
S5	REVISED SSDA	S5.00

Project Address
**269 LANE COVE ROAD,
MAQUARIE PARK,
SYDNEY, NSW 2113**

Project Name
NEXTDC DATA CENTRE

Drawing Title
**GENERAL
ARRANGEMENT PLAN 6**

Drawing Status
Development Application

Drawn	PM	Date
CHECKED	SE	26/09/2025
APPROVED	MB	26/09/2025

Scale	Sheet	File Name
1 : 100	A1	SS-LAD-ALA-DRG-0-0101-L0206
Dwg no:		Rev
SS-LAD-ALA-DRG-0-0101-L0206		7

26/09/2025 2:46:59 PM

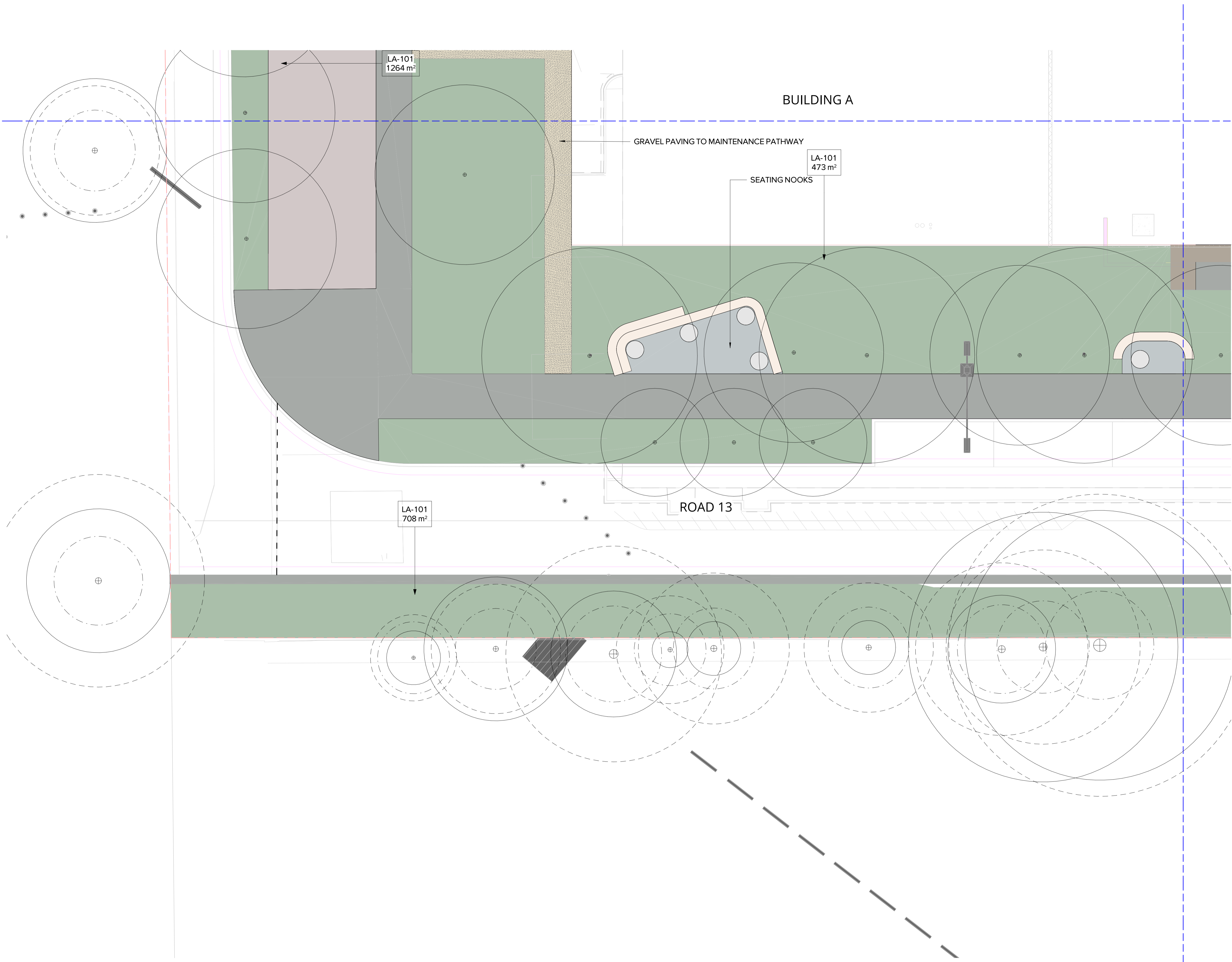

DATE	No.	REVISION HISTORY	DRW	CHK	QA
26/09/2025	7	SSDA	PM	MM	
21/09/2025	6	SSDA	MM	MM	
10/09/2025	5	SSDA	SE	MM	
11/09/2025	4	SSDA	SE	MM	
28/09/2024	3	SSDA	SE	MM	
30/09/2024	2	SSDA	SE	MM	
18/09/2024	1	SSDA	SE	MM	

- NOTE:
1. ALL DRAWINGS TO BE READ IN CONJUNCTION WITH ASSOCIATED SPECIFICATION
 2. DO NOT SCALE FROM DRAWINGS
 3. CONFIRM ALL MEASUREMENTS ON SITE
 4. CHECK ON SITE PRIOR TO CONSTRUCTION AND REPORT ANY DISCREPANCIES
 5. ENSURE COORDINATION WITH OTHER TRADES ON SITE

PRINCIPAL CONSULTANTS

Architect HDR

Services ARUP

Structural TTW

PRINCIPAL CONTRACTOR

Multiplex

CLIENT



NEXTDC

NEXTDC
GPO Box 3219
Brisbane QLD 4001
T: +61 7 3177 4777

ARCHITECT



LANDSCAPE ARCHITECT



Document Author Project Number

24-1002

Key Plan



Site	Stage	REVISIED	NEXTDC Project Number
S5	SSDA	SSDA	S5.00

Project Address

269 LANE COVE ROAD,
MAQUARIE PARK,
SYDNEY, NSW 2113

Project Name

NEXTDC DATA CENTRE

Drawing Title

GENERAL
ARRANGEMENT PLAN 7

Drawing Status

Development Application

Drawn	By	Date
PM	PM	26/09/2025
Checked	By	Date
SE	SE	26/09/2025
Approved	By	Date
MB	MB	26/09/2025

Scale	Sheet	File Name
1 : 100	A1	SS-LAD-ALA-DRG-0-0101-L0207
Dwg no:	Rev	
SS-LAD-ALA-DRG-0-0101-L0207	7	

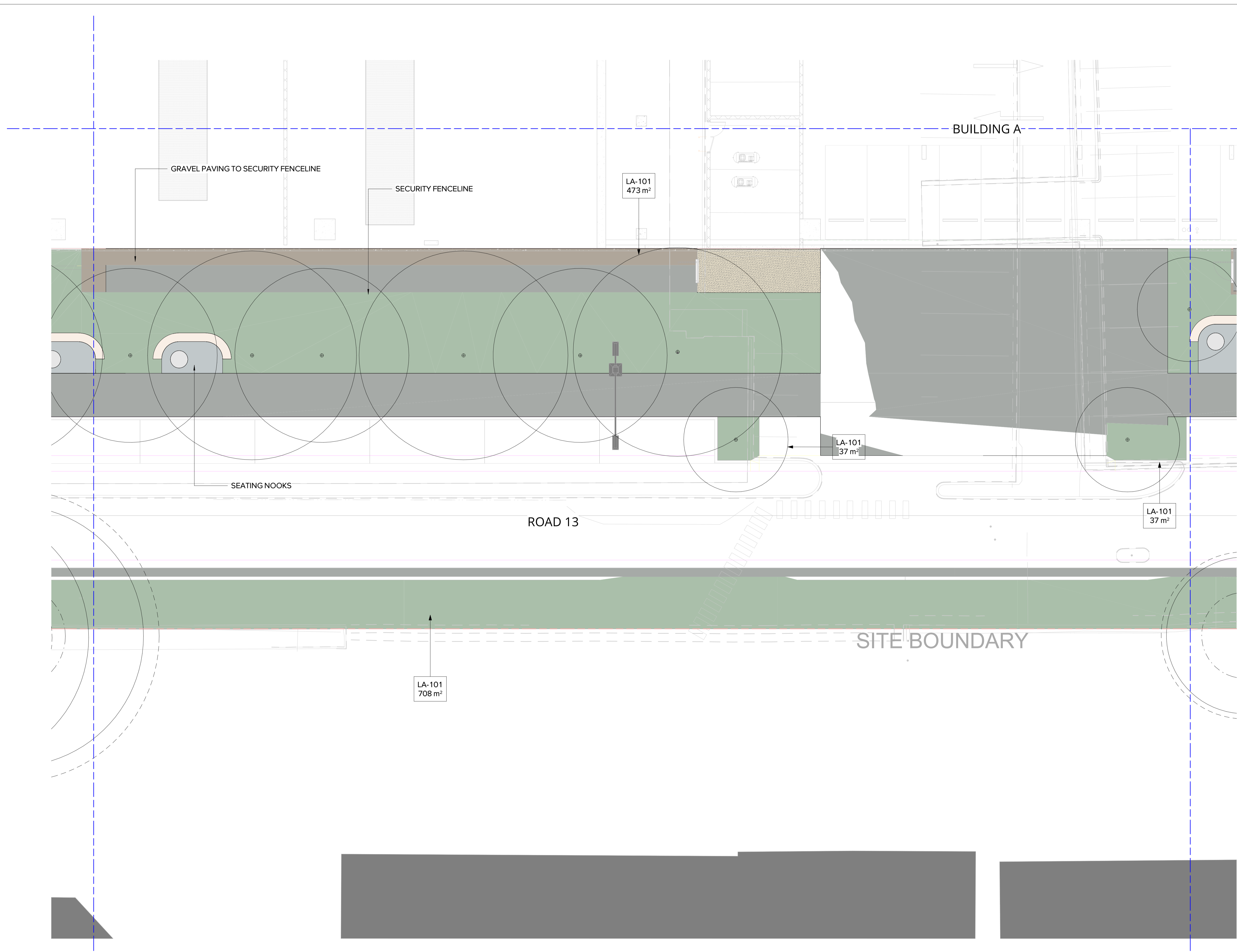

DATE	No.	REVISION HISTORY	DRW	CHK	QA
26/09/2025	7	SSDA	PM	MM	
21/09/2025	6	SSDA	MM	MM	
10/09/2025	5	SSDA	SE	MM	
11/09/2025	4	SSDA	SE	MM	
28/09/2024	3	SSDA	MM	MM	
30/09/2024	2	SSDA	SE	MM	
18/09/2024	1	SSDA	SE	MM	

NOTE:
 1. ALL DRAWINGS TO BE READ IN CONJUNCTION WITH ASSOCIATED SPECIFICATION
 2. DO NOT SCALE FROM DRAWINGS
 3. CONFIRM ALL MEASUREMENTS ON SITE
 4. CHECK ON SITE PRIOR TO CONSTRUCTION AND REPORT ANY DISCREPANCIES
 5. ENSURE COORDINATION WITH OTHER TRADES ON SITE

PRINCIPAL CONSULTANTS
 Architect HDR
 Services ARUP
 Structural TTW

PRINCIPAL CONTRACTOR
Multiplex

CLIENT



NEXTDC
 NEXTDC
 GPO Box 3219
 Brisbane QLD 4001
 T: +61 7 3177 4777

ARCHITECT



LANDSCAPE ARCHITECT



Document Author Project Number
 24-1002

Key Plan



Site	Stage	NEXTDC Project Number
S5	REVISED SSDA	S5.00

Project Address
 269 LANE COVE ROAD,
 MAQUARIE PARK,
 SYDNEY, NSW 2113

Project Name
 NEXTDC DATA CENTRE

Drawing Title
 GENERAL
 ARRANGEMENT PLAN 8

Drawing Status
 Development Application

Drawn	PM	Date	26/09/2025
Checked	SE	Date	26/09/2025
Approved	MB	Date	26/09/2025

Scale	Sheet	File Name
1 : 100	A1	SS-LAD-ALA-DRG-0-0101-L0208
Dwg no:		Rev
SS-LAD-ALA-DRG-0-0101-L0208		7

26/09/2025 2:47:16 PM

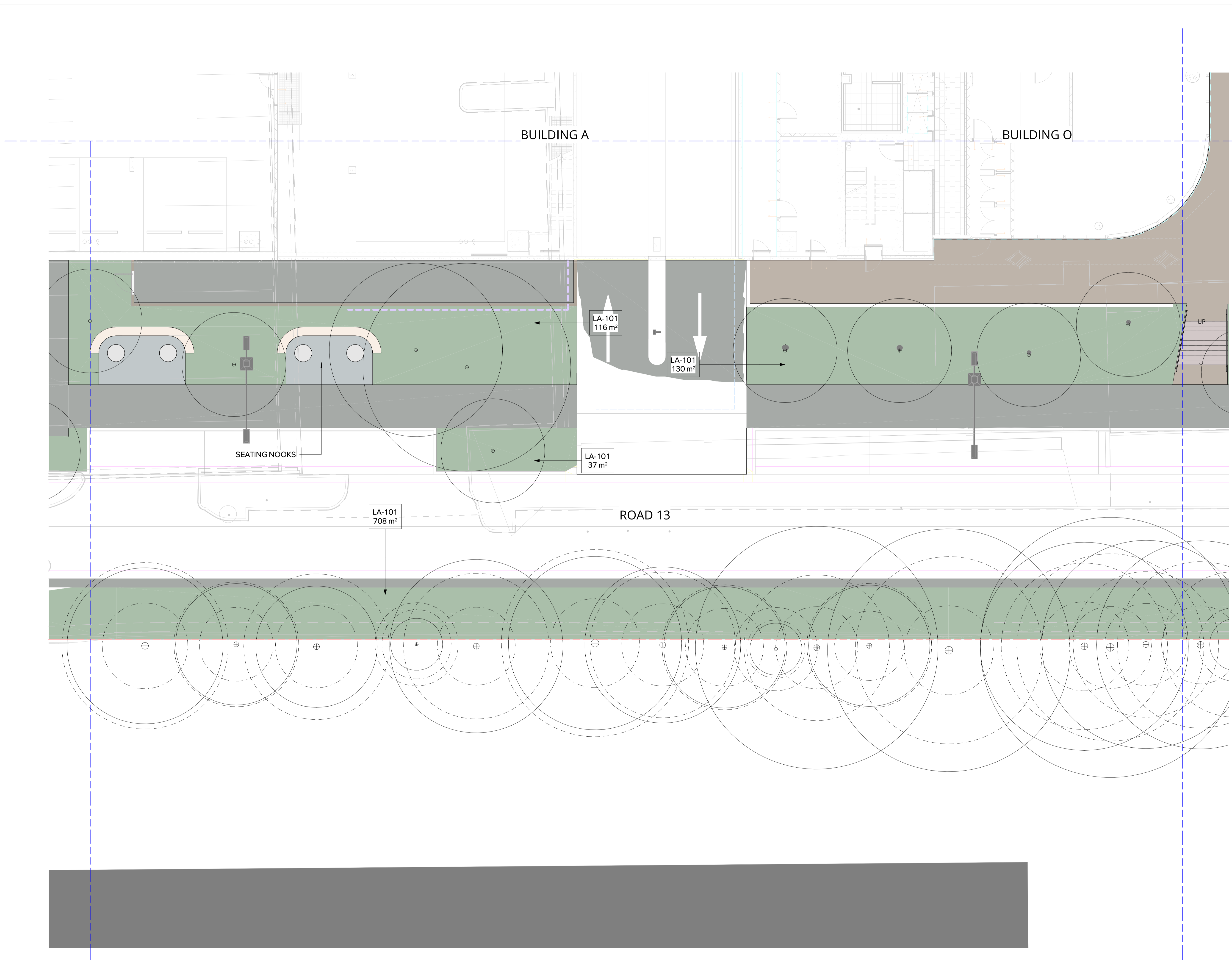

DATE	NO.	REVISION HISTORY	DRW	CHK	QA
26/09/2025	7	SSDA	PM	MM	
21/09/2025	6	SSDA	MM	MM	
10/09/2025	5	SSDA	SE	MM	
11/09/2025	4	SSDA	SE	MM	
28/09/2024	3	SSDA	SE	MM	
30/09/2024	2	SSDA	SE	MM	
19/09/2024	1	SSDA	SE	MM	

NOTE:
 1. ALL DRAWINGS TO BE READ IN CONJUNCTION WITH ASSOCIATED SPECIFICATION
 2. DO NOT SCALE FROM DRAWINGS
 3. CONFIRM ALL MEASUREMENTS ON SITE
 4. CHECK ON SITE PRIOR TO CONSTRUCTION AND REPORT ANY DISCREPANCIES
 5. ENSURE COORDINATION WITH OTHER TRADES ON SITE

PRINCIPAL CONSULTANTS
 Architect HDR
 Services ARUP
 Structural TTW

PRINCIPAL CONTRACTOR
Multiplex

CLIENT



NEXTDC
 NEXTDC
 GPO Box 3219
 Brisbane QLD 4001
 T: +61 7 3177 4777

ARCHITECT

LANDSCAPE ARCHITECT

Document Author Project Number
 24-1002

Key Plan



Site	Stage	NEXTDC Project Number
S5	REVISED SSDA	S5.00

Project Address
**269 LANE COVE ROAD,
 MAQUARIE PARK,
 SYDNEY, NSW 2113**

Project Name
NEXTDC DATA CENTRE

Drawing Title
**GENERAL
 ARRANGEMENT PLAN 9**

Drawing Status
Development Application

Drawn	PM	Date	26/09/2025
Checked	SE	Date	26/09/2025
Approved	MB	Date	26/09/2025

Scale	Sheet	File Name
1 : 100	A1	SS-LAD-ALA-DRG-0-0101-L0209
Dwg no:		Rev
SS-LAD-ALA-DRG-0-0101-L0209		7

Autodesk Docs://10710471_NEXTDC_S5ABG_2025/SS-LAD-ALA-DRG-0-0101-L0209.dwg

26/09/2025 2:47:28 PM

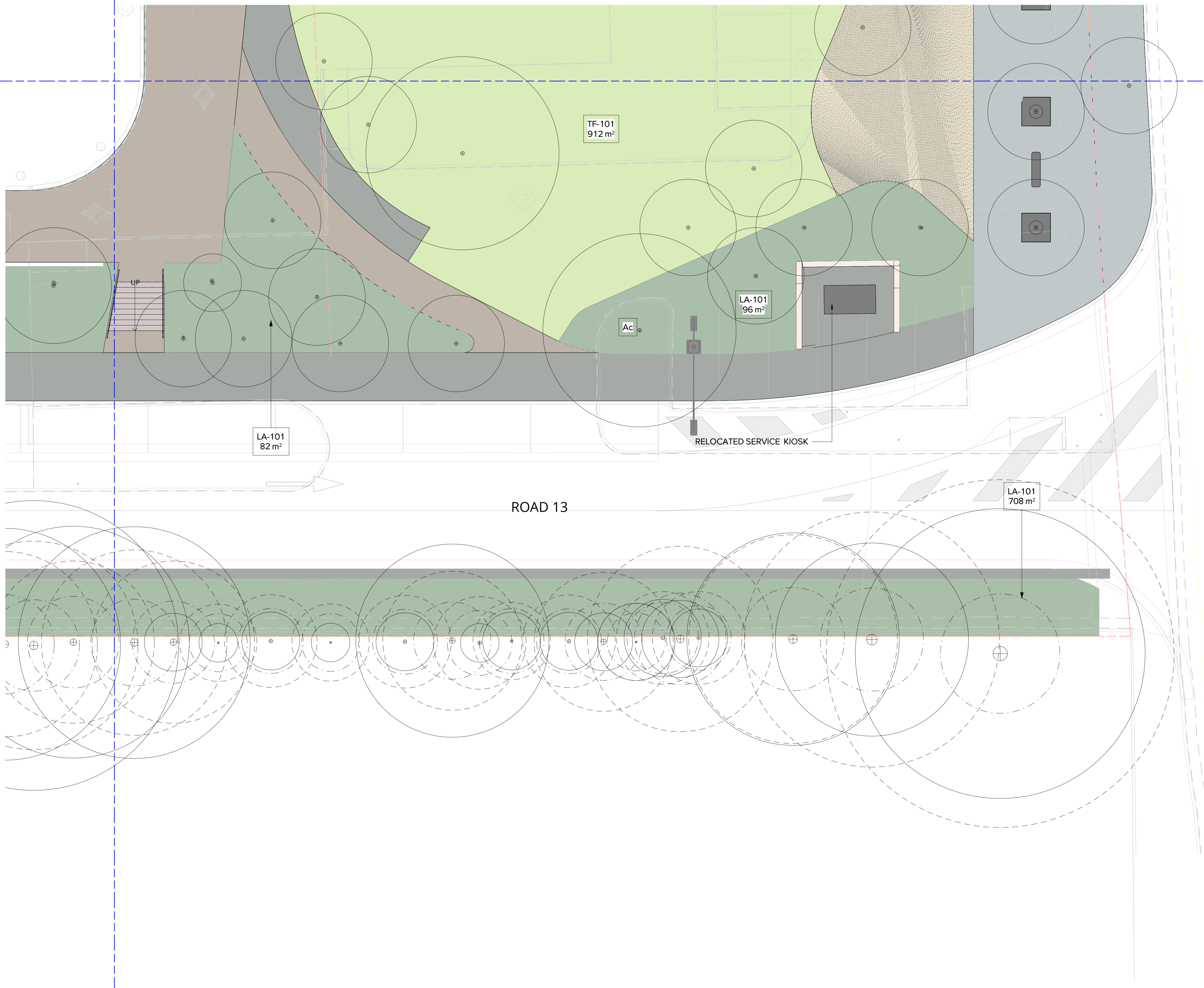

DATE	No.	REVISION HISTORY	DRW	CHK	QA
26/09/2025	7	SSDA	PM	MM	MM
21/09/2025	6	SSDA	MM	SE	MM
10/09/2025	5	SSDA	SE	SE	MM
11/09/2025	4	SSDA	SE	SE	MM
28/09/2024	3	SSDA	SE	SE	MM
30/09/2024	2	SSDA	SE	SE	MM
18/09/2024	1	SSDA	SE	SE	MM

- NOTE:
1. ALL DRAWINGS TO BE READ IN CONJUNCTION WITH ASSOCIATED SPECIFICATION
 2. DO NOT SCALE FROM DRAWINGS
 3. CONFIRM ALL MEASUREMENTS ON SITE
 4. CHECK ON SITE PRIOR TO CONSTRUCTION AND REPORT ANY DISCREPANCIES
 5. ENSURE COORDINATION WITH OTHER TRADES ON SITE

PRINCIPAL CONSULTANTS

Architect HDR
 Services ARUP
 Structural TTW

PRINCIPAL CONTRACTOR
Multiplex

CLIENT



NEXTDC

NEXTDC
 GPO Box 3219
 Brisbane QLD 4001
 T: +61 7 3177 4777

ARCHITECT



LANDSCAPE ARCHITECT



Document Author Project Number
 24-1002

Key Plan



Site	Stage	NEXTDC Project Number
S5	REVISED SSDA	S5.00

Project Address
**269 LANE COVE ROAD,
 MAQUARIE PARK,
 SYDNEY, NSW 2113**

Project Name
NEXTDC DATA CENTRE

Drawing Title
**GENERAL
 ARRANGEMENT PLAN 10**

Drawing Status
Development Application

Drawn	Date
PM	26/09/2025
Checked	Date
SE	26/09/2025
Approved	Date
MB	26/09/2025

Scale	Sheet	File Name
1 : 100	A1	SS-LAD-ALA-DRG-0-0101-L0210
Dwg no:	Rev	
SS-LAD-ALA-DRG-0-0101-L0210	7	

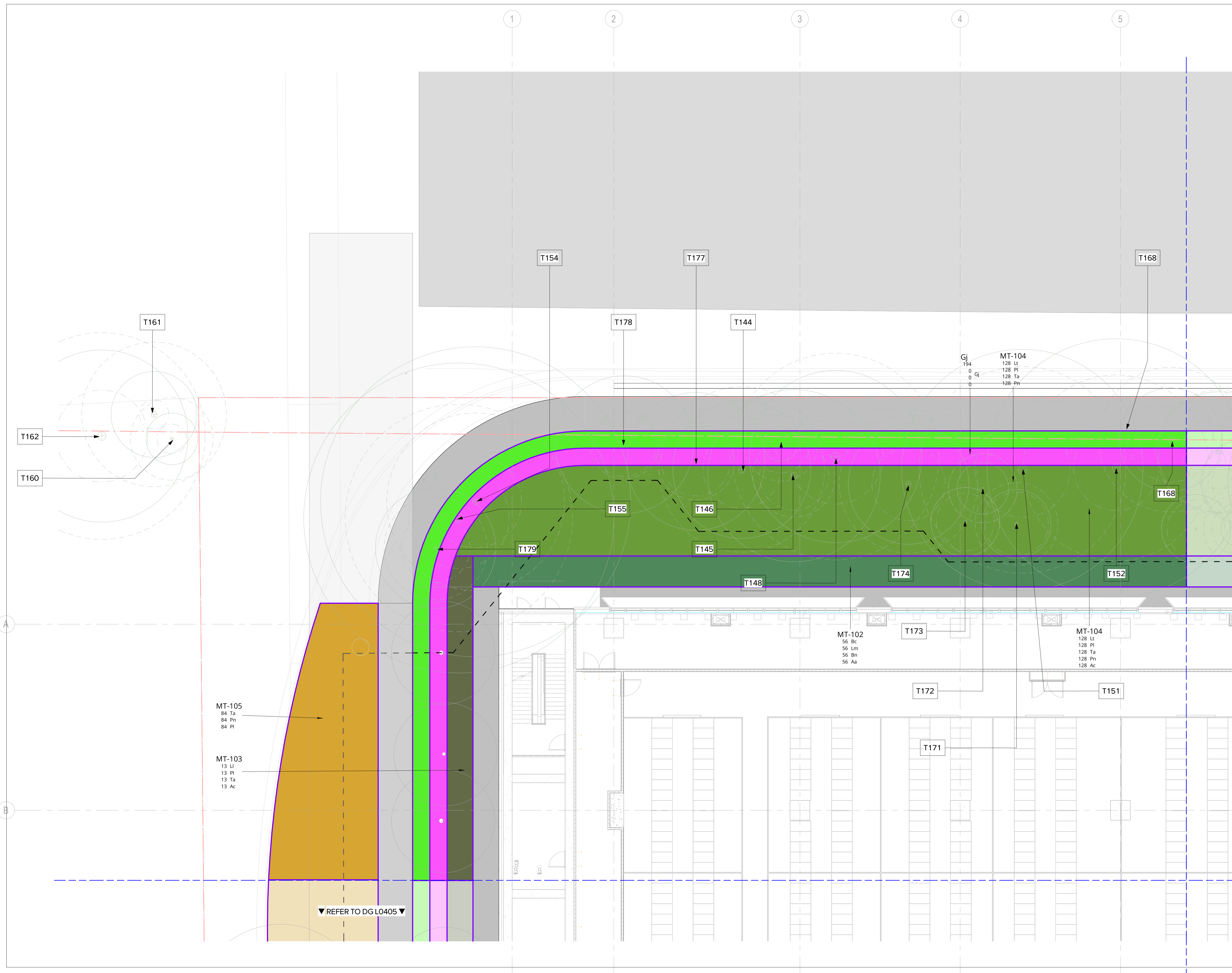

DATE	No.	REVISION HISTORY	DRW	CHK	QA
26/09/2025	7	SSDA	MM		
31/03/2025	6	SSDA	MM		
10/03/2025	5	SSDA	SE		
11/02/2025	4	SSDA	SE		
28/10/2024	3	SSDA	SE		
30/09/2024	2	SSDA	SE		
16/04/2024	1	SSDA	SE		

NOTE:
 1. ALL DRAWINGS TO BE READ IN CONJUNCTION WITH ASSOCIATED SPECIFICATION
 2. DO NOT SCALE FROM DRAWINGS
 3. CONFIRM ALL MEASUREMENTS ON SITE
 4. CHECK ON SITE PRIOR TO CONSTRUCTION AND REPORT ANY DISCREPANCIES
 5. ENSURE COORDINATION WITH OTHER TRADES ON SITE

PRINCIPAL CONSULTANTS
 Architect HDR
 Services ARUP
 Structural TTW

PRINCIPAL CONTRACTOR
Multiplex

CLIENT

NEXTDC
 NEXTDC
 GPO Box 3219
 Brisbane QLD 4001
 T: +61 7 3177 4777

ARCHITECT

LANDSCAPE ARCHITECT

Document Author Project Number
 24-1002

Key Plan

Site	Stage	REVISSED	SSDA	NEXTDC Project Number
S5				S5.00

Project Address
 269 LANE COVE ROAD,
 MAQUARIE PARK,
 SYDNEY, NSW 2113

Project Name
 NEXTDC DATA CENTRE

Drawing Title
 SOFTWARES PLAN 1

Drawing Status
 Development Application

Drawn	PM	Date
		26/09/2025
Checked	SE	Date
		26/09/2025
Approved	MB	Date
		26/09/2025
Scale	Sheet	File Name
1 : 100	A1	SS-LAD-ALA-DRG-0-0101-L0401
Dwg no:	Rev	
SS-LAD-ALA-DRG-0-0101-L0401	7	

▼ REFER TO DG L0402 ▼

▼ REFER TO DG L0405 ▼

Autodesk Docs://10710471_NEXTDC_S5ABG_2025/SS-LAD-ALA-DRG-0-0101-L0401.rvt

26/09/2025 2:47:50 PM

6

7

8

9

10

11

12

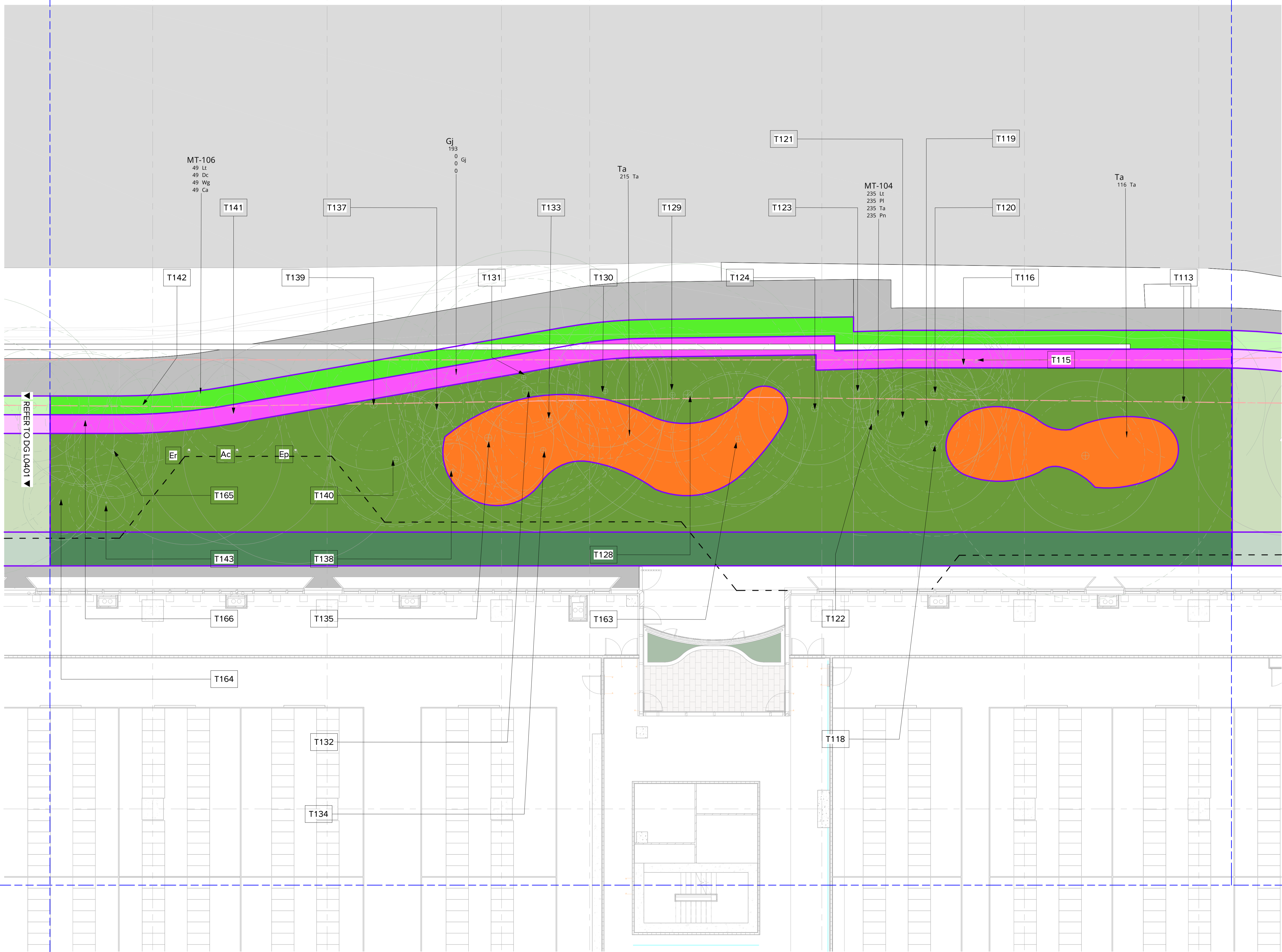

REFER TO DG L0401

REFER TO DG L0403

DATE	No.	REVISION HISTORY	DRW	CHK	QA
26/09/2025	7	SSDA	PM	MM	
21/09/2025	6	SSDA	MM	MM	
10/09/2025	5	SSDA	SE	MM	
11/09/2025	4	SSDA	SE	MM	
28/09/2024	3	SSDA	SE	MM	
30/09/2024	2	SSDA	SE	MM	
18/09/2024	1	SSDA	SE	MM	

- NOTE:
1. ALL DRAWINGS TO BE READ IN CONJUNCTION WITH ASSOCIATED SPECIFICATION
 2. DO NOT SCALE FROM DRAWINGS
 3. CONFIRM ALL MEASUREMENTS ON SITE
 4. CHECK ON SITE PRIOR TO CONSTRUCTION AND REPORT ANY DISCREPANCIES
 5. ENSURE COORDINATION WITH OTHER TRADES ON SITE

PRINCIPAL CONSULTANTS

Architect HDR
 Services ARUP
 Structural TTW

PRINCIPAL CONTRACTOR
Multiplex

CLIENT

NEXTDC

NEXTDC
 GPO Box 3219
 Brisbane QLD 4001
 T: +61 7 3177 4777

ARCHITECT

LANDSCAPE ARCHITECT

Document Author Project Number
 24-1002

Key Plan

Site	Stage	NEXTDC Project Number
S5	REVISED SSDA	S5.00

Project Address
**269 LANE COVE ROAD,
 MAQUARIE PARK,
 SYDNEY, NSW 2113**

Project Name
NEXTDC DATA CENTRE

Drawing Title
SOFTWARES PLAN 2

Drawing Status
Development Application

Drawn	Checkd	Apprvd	Date
PM	SE	MB	26/09/2025
			26/09/2025
			26/09/2025

Scale	Sheet	File Name
1 : 100	A1	SS-LAD-ALA-DRG-0-0101-L0402
Dwg no:		Rev
SS-LAD-ALA-DRG-0-0101-L0402		7

26/09/2025 2:48:00 PM

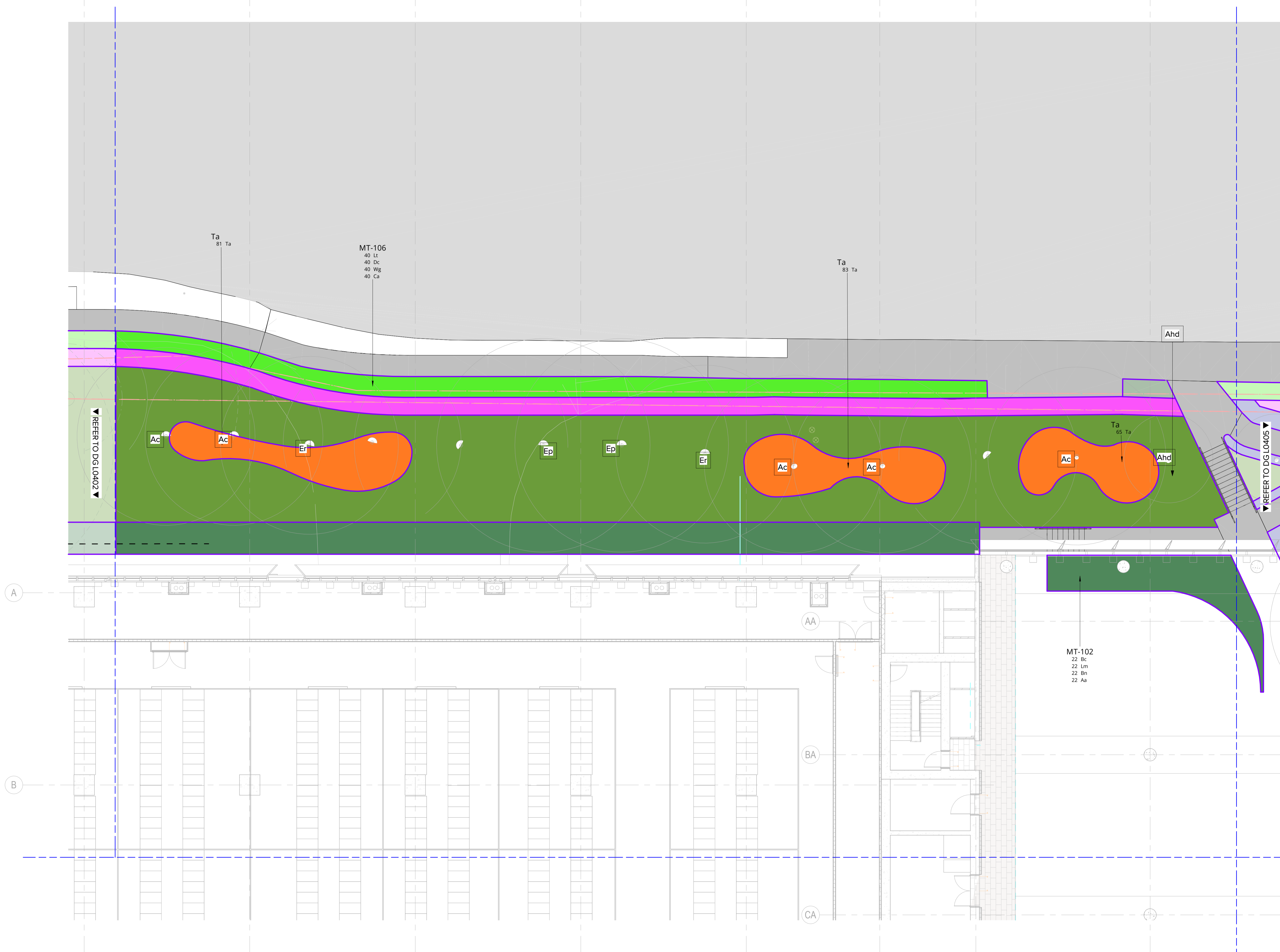

DATE	No.	REVISION HISTORY	DRW	CHK	QA
26/09/2025	7	SSDA	PM	MM	
31/03/2025	6	SSDA	MM	MM	
10/03/2025	5	SSDA	SE	MM	
11/02/2025	4	SSDA	SE	MM	
28/10/2024	3	SSDA	SE	MM	
30/05/2024	2	SSDA	SE	MM	
18/04/2024	1	SSDA	SE	MM	

NOTE:
 1. ALL DRAWINGS TO BE READ IN CONJUNCTION WITH ASSOCIATED SPECIFICATION
 2. DO NOT SCALE FROM DRAWINGS
 3. CONFIRM ALL MEASUREMENTS ON SITE
 4. CHECK ON SITE PRIOR TO CONSTRUCTION AND REPORT ANY DISCREPANCIES
 5. ENSURE COORDINATION WITH OTHER TRADES ON SITE

PRINCIPAL CONSULTANTS
 Architect HDR
 Services ARUP
 Structural TTW

PRINCIPAL CONTRACTOR
Multiplex

CLIENT



NEXTDC
 NEXTDC
 GPO Box 3219
 Brisbane QLD 4001
 T: +61 7 3177 4777

ARCHITECT



LANDSCAPE ARCHITECT



Document Author Project Number
 24-1002

Key Plan 

Site	Stage	REVISSED	NEXTDC Project Number
S5	SSDA	SSDA	S5.00

Project Address
 269 LANE COVE ROAD,
 MAQUARIE PARK,
 SYDNEY, NSW 2113

Project Name
 NEXTDC DATA CENTRE

Drawing Title
 SOFTWARES PLAN 3

Drawing Status
 Development Application

Drawn	PM	Date	26/09/2025
Checked	SE	Date	26/09/2025
Approved	MB	Date	26/09/2025

Scale	Sheet	File Name
1 : 100	A1	SS-LAD-ALA-DRG-0-0101-L0403
Dwg no:		Rev
SS-LAD-ALA-DRG-0-0101-L0403		7

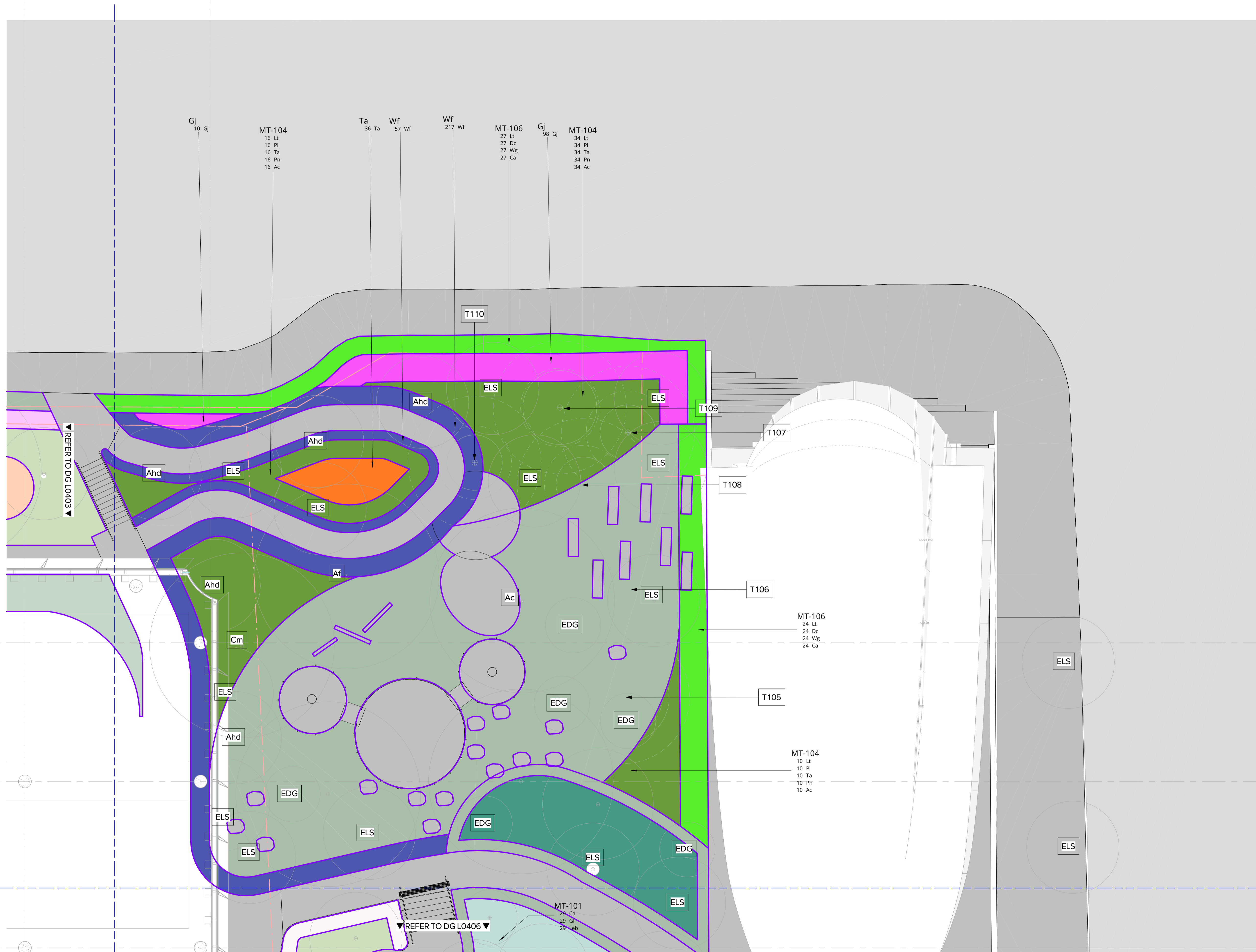

DATE	No.	REVISION HISTORY	DRW	CHK	QA
26/09/2025	7	SSDA	PM	MM	
31/03/2025	6	SSDA	MM	MM	
10/03/2025	5	SSDA	SE	MM	
11/02/2025	4	SSDA	SE	MM	
28/10/2024	3	SSDA	SE	MM	
30/05/2024	2	SSDA	SE	MM	
18/04/2024	1	SSDA	SE	MM	

- NOTE:
1. ALL DRAWINGS TO BE READ IN CONJUNCTION WITH ASSOCIATED SPECIFICATION
 2. DO NOT SCALE FROM DRAWINGS
 3. CONFIRM ALL MEASUREMENTS ON SITE
 4. CHECK ON SITE PRIOR TO CONSTRUCTION AND REPORT ANY DISCREPANCIES
 5. ENSURE COORDINATION WITH OTHER TRADES ON SITE

PRINCIPAL CONSULTANTS

Architect HDR
 Services ARUP
 Structural TTW

PRINCIPAL CONTRACTOR
Multiplex

CLIENT

NEXTDC

NEXTDC
 GPO Box 3219
 Brisbane QLD 4001
 T: +61 7 3177 4777

ARCHITECT

HDR

LANDSCAPE ARCHITECT

ARCADIA

Document Author Project Number
 24-1002

Key Plan

Site	Stage	REVISOR	NEXTDC Project Number
S5	REVISED	SSDA	S5.00

Project Address
 269 LANE COVE ROAD,
 MAQUARIE PARK,
 SYDNEY, NSW 2113

Project Name
 NEXTDC DATA CENTRE

Drawing Title
 SOFTWARES PLAN 4

Drawing Status
 Development Application

Drawn	PM	Date
SE <td>MM</td> <td>26/09/2025</td>	MM	26/09/2025
Checked	SE	Date
MM	MM	26/09/2025
Approved	MB	Date
MM	MM	26/09/2025

Scale	Sheet	File Name
1 : 100	A1	SS-LAD-ALA-DRG-0-0101-L0404
Dwg no:	Rev	
SS-LAD-ALA-DRG-0-0101-L0404	7	

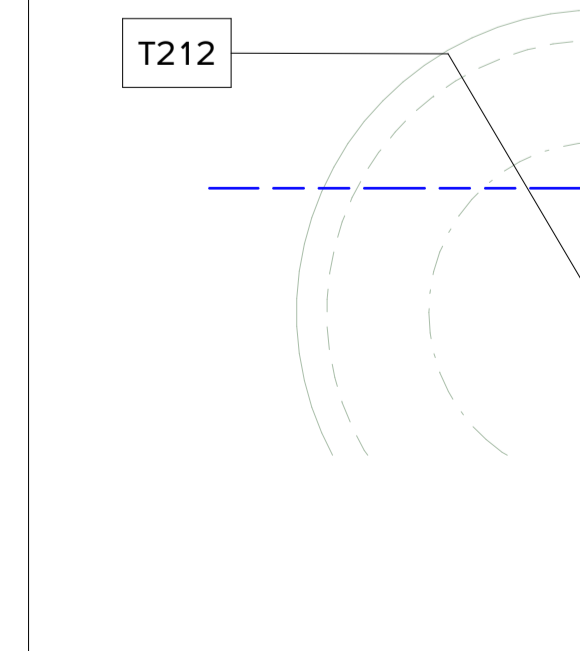
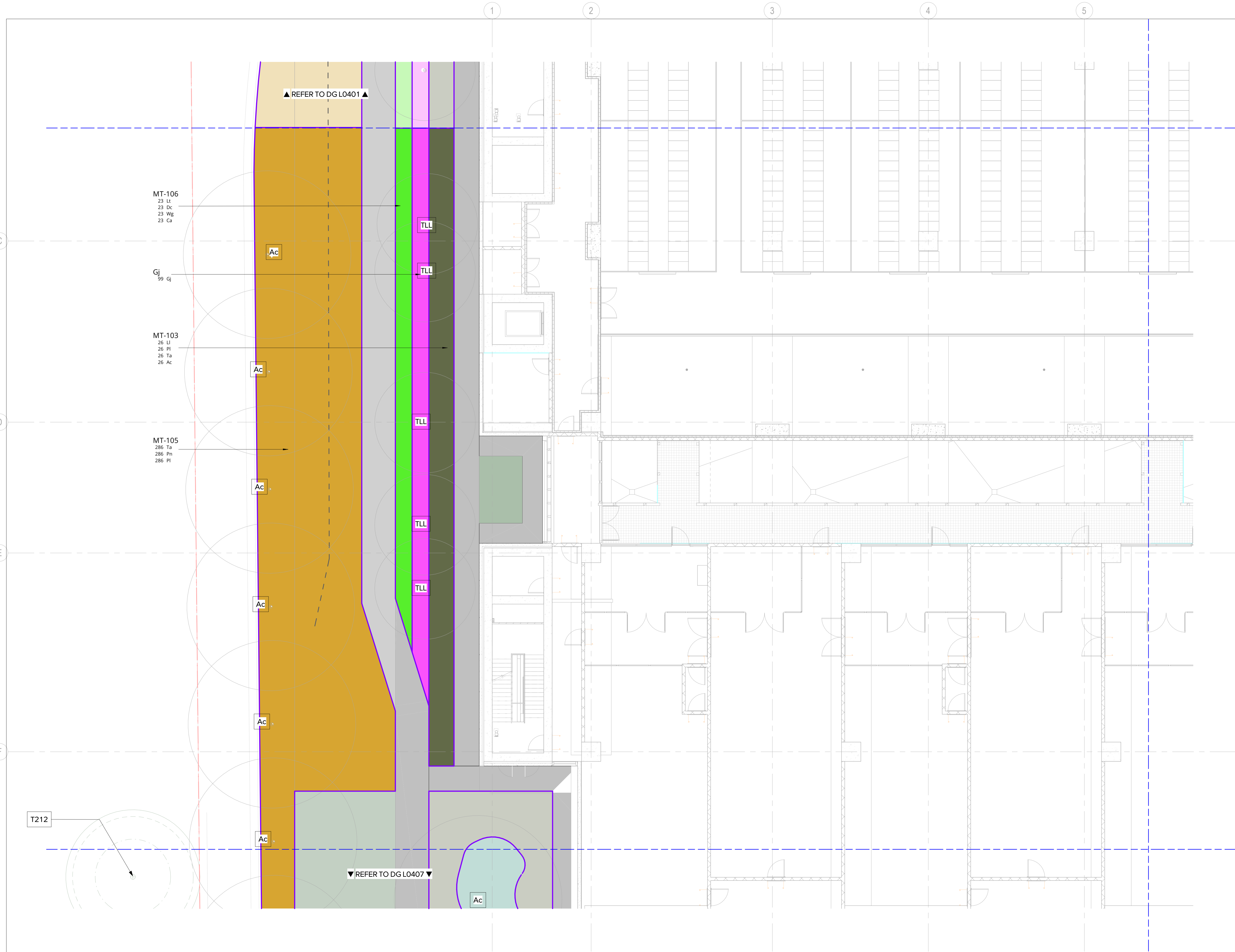

26/09/2025	7	SSDA	MM	MM
31/03/2025	6	SSDA	MM	MM
10/03/2025	5	SSDA	SE	MM
11/02/2025	4	SSDA	SE	MM
28/02/2024	3	SSDA	SE	MM
30/05/2024	2	SSDA	SE	MM
18/04/2024	1	SSDA	SE	MM
DATE	No.	REVISION HISTORY	DRW	CHK

NOTE:

- ALL DRAWINGS TO BE READ IN CONJUNCTION WITH ASSOCIATED SPECIFICATION
- DO NOT SCALE FROM DRAWINGS
- CONFIRM ALL MEASUREMENTS ON SITE
- CHECK ON SITE PRIOR TO CONSTRUCTION AND REPORT ANY DISCREPANCIES
- ENSURE COORDINATION WITH OTHER TRADES ON SITE

PRINCIPAL CONSULTANTS

Architect HDR
 Services ARUP
 Structural TTW

PRINCIPAL CONTRACTOR
Multiplex

CLIENT



NEXTDC

NEXTDC
 GPO Box 3219
 Brisbane QLD 4001
 T: +61 7 3177 4777

ARCHITECT



LANDSCAPE ARCHITECT



Document Author Project Number
 24-1002

Key Plan



Site	Stage	NEXTDC Project Number
S5	REVISED SSDA	S5.00

Project Address
**269 LANE COVE ROAD,
 MAQUARIE PARK,
 SYDNEY, NSW 2113**

Project Name
NEXTDC DATA CENTRE

Drawing Title
SOFTWARES PLAN 5

Drawing Status
Development Application

Drawn	PM	Date	26/09/2025
Checked	SE	Date	26/09/2025
Approved	MB	Date	26/09/2025

Scale Sheet File Name
 1 : 100 A1 SS-LAD-ALA-DRG-0-0101-L0405

Dwg no:	Rev
SS-LAD-ALA-DRG-0-0101-L0405	7

26/09/2025 2:48:58 PM

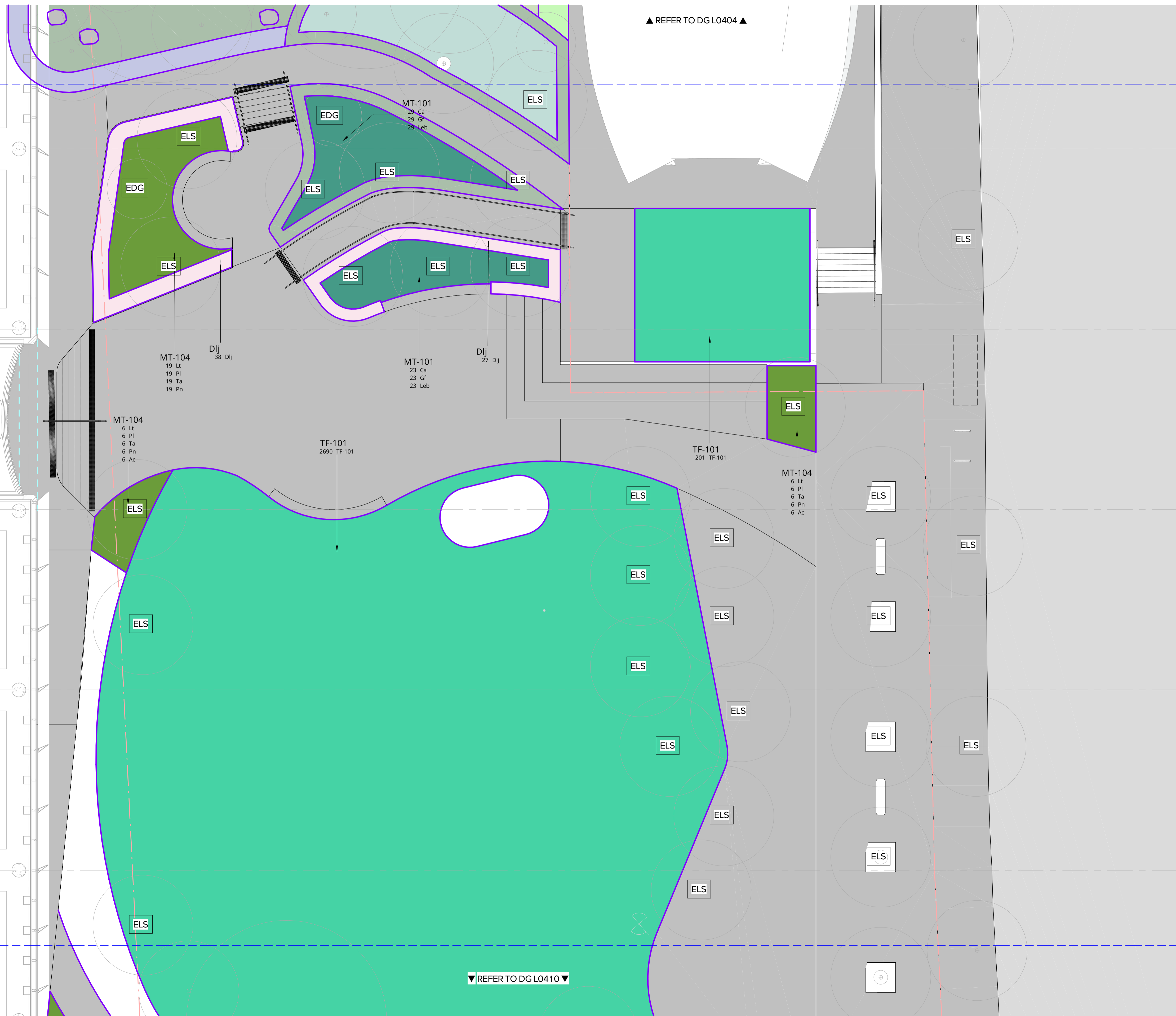

DATE	No.	REVISION HISTORY	DRW	CHK	QA
26/09/2025	7	SSDA	PM	MM	MM
21/09/2025	6	SSDA	MM	MM	MM
10/09/2025	5	SSDA	SE	MM	MM
11/02/2025	4	SSDA	SE	MM	MM
28/05/2024	3	SSDA	SE	MM	MM
30/05/2024	2	SSDA	SE	MM	MM
18/02/2024	1	SSDA	SE	MM	MM

- NOTE:
1. ALL DRAWINGS TO BE READ IN CONJUNCTION WITH ASSOCIATED SPECIFICATION
 2. DO NOT SCALE FROM DRAWINGS
 3. CONFIRM ALL MEASUREMENTS ON SITE
 4. CHECK ON SITE PRIOR TO CONSTRUCTION AND REPORT ANY DISCREPANCIES
 5. ENSURE COORDINATION WITH OTHER TRADES ON SITE

PRINCIPAL CONSULTANTS

Architect HDR

Services ARUP

Structural TTW

PRINCIPAL CONTRACTOR
Multiplex

CLIENT

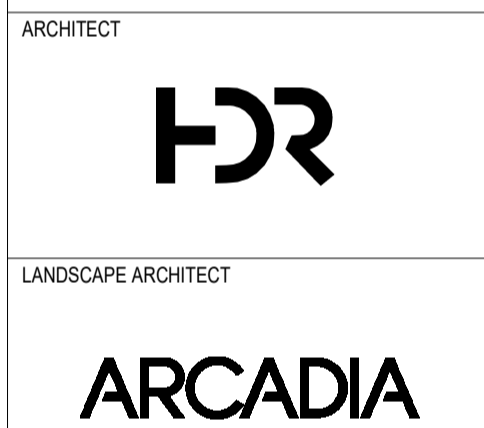

Document Author Project Number
24-1002

Key Plan

Site	Stage	NEXTDC Project Number
S5	REVISED SSDA	S5.00

Project Address
269 LANE COVE ROAD,
MAQUARIE PARK,
SYDNEY, NSW 2113

Project Name
NEXTDC DATA CENTRE

Drawing Title
SOFTWARES PLAN 6

Drawing Status
Development Application

Drawn	Day
PM	26/09/2025
Checked	Day
SE	26/09/2025
Approved	Day
MB	26/09/2025

Scale	Sheet	File Name
1 : 100	A1	SS-LAD-ALA-DRG-0-0101-L0406
Dwg no:	Rev	
SS-LAD-ALA-DRG-0-0101-L0406	7	

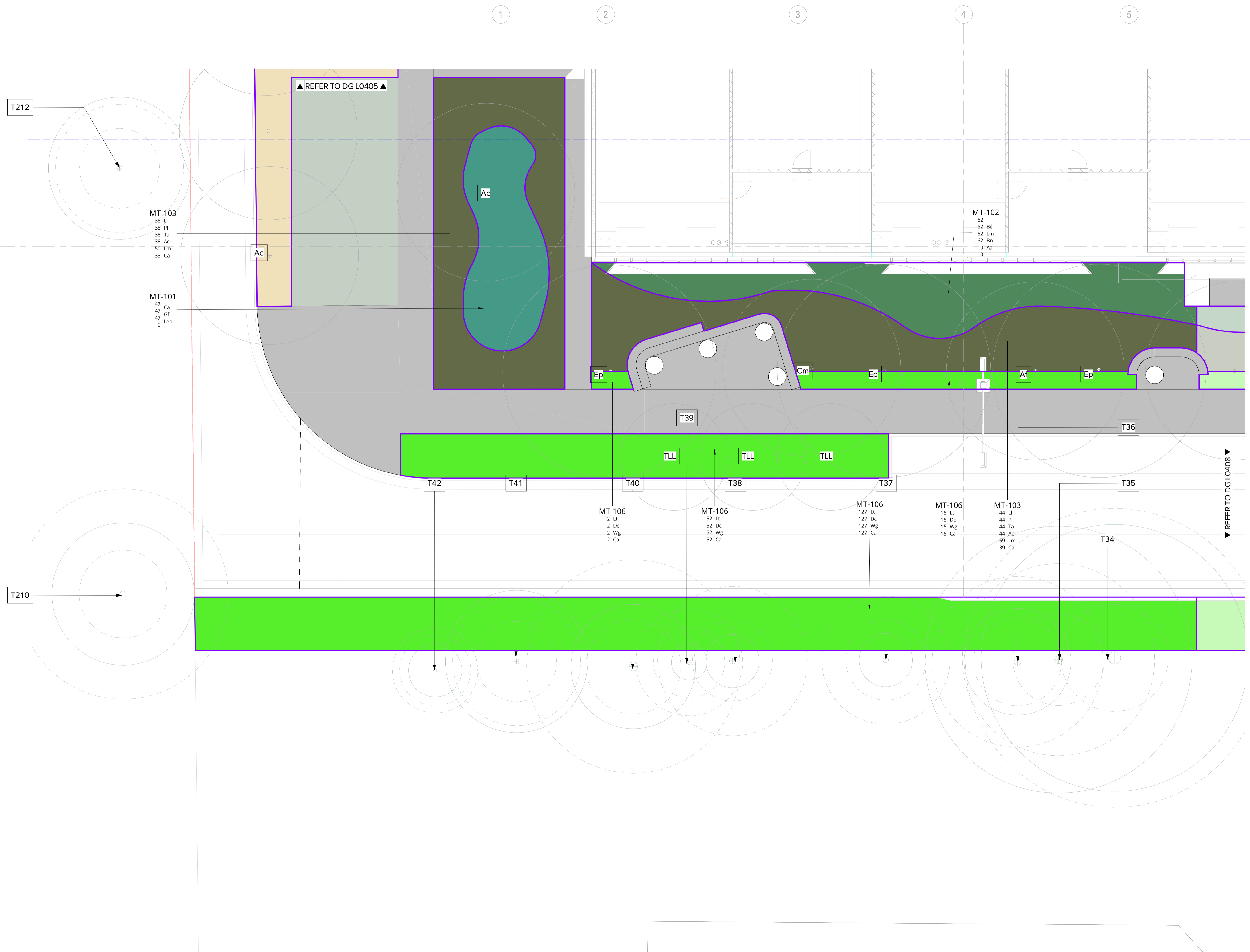

DATE	No.	REVISION HISTORY	DRW	CHK	QA
26/09/2025	7	SSDA	PM	MM	
21/09/2025	6	SSDA	MM	MM	
10/09/2025	5	SSDA	SE	MM	
11/09/2025	4	SSDA	SE	MM	
28/09/2024	3	SSDA	SE	MM	
30/09/2024	2	SSDA	SE	MM	
18/09/2024	1	SSDA	SE	MM	

NOTE:
 1. ALL DRAWINGS TO BE READ IN CONJUNCTION WITH ASSOCIATED SPECIFICATION
 2. DO NOT SCALE FROM DRAWINGS
 3. CONFIRM ALL MEASUREMENTS ON SITE
 4. CHECK ON SITE PRIOR TO CONSTRUCTION AND REPORT ANY DISCREPANCIES
 5. ENSURE COORDINATION WITH OTHER TRADES ON SITE

PRINCIPAL CONSULTANTS
 Architect HDR
 Services ARUP
 Structural TTW

PRINCIPAL CONTRACTOR
Multiplex

CLIENT



NEXTDC
 NEXTDC
 GPO Box 5219
 Brisbane QLD 4001
 T: +61 7 3177 4777

ARCHITECT



LANDSCAPE ARCHITECT



Document Author Project Number
 24-1002

Key Plan



Site	Stage	REVISSED	SSDA	NEXTDC Project Number
S5				S5.00

Project Address
 269 LANE COVE ROAD,
 MAQUARIE PARK,
 SYDNEY, NSW 2113

Project Name
 NEXTDC DATA CENTRE

Drawing Title
 SOFTWARES PLAN 7

Drawing Status
 Development Application

Drawn	PM	Date
SE	MM	26/09/2025
Checked	SE	Date
SE	MM	26/09/2025
Approved	MB	Date
SE	MM	26/09/2025

Scale	Sheet	File Name
1 : 100	A1	SS-LAD-ALA-DRG-0-0101-L0407
Dwg no:	Rev	
SS-LAD-ALA-DRG-0-0101-L0407	7	

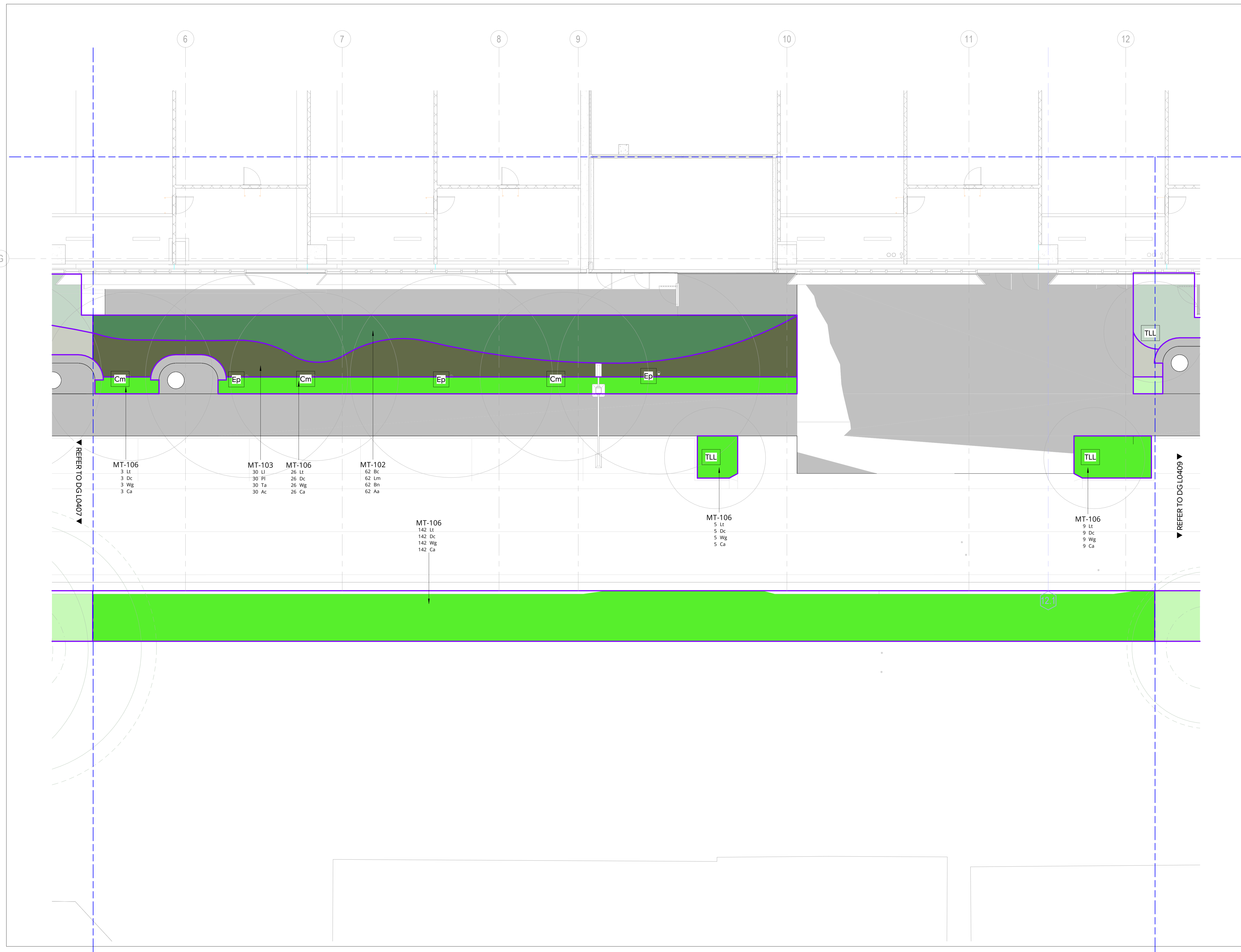

DATE	No.	REVISION HISTORY	DRW	CHK	QA
26/09/2025	7	SSDA	PM	MM	
21/09/2025	6	SSDA	MM	MM	
10/09/2025	5	SSDA	SE	MM	
11/09/2025	4	SSDA	SE	MM	
28/09/2024	3	SSDA	SE	MM	
30/09/2024	2	SSDA	SE	MM	
18/04/2024	1	SSDA	SE	MM	

NOTE:
 1. ALL DRAWINGS TO BE READ IN CONJUNCTION WITH ASSOCIATED SPECIFICATION
 2. DO NOT SCALE FROM DRAWINGS
 3. CONFIRM ALL MEASUREMENTS ON SITE
 4. CHECK ON SITE PRIOR TO CONSTRUCTION AND REPORT ANY DISCREPANCIES
 5. ENSURE COORDINATION WITH OTHER TRADES ON SITE

PRINCIPAL CONSULTANTS
 Architect HDR
 Services ARUP
 Structural TTW

PRINCIPAL CONTRACTOR
Multiplex

CLIENT



NEXTDC
 NEXTDC
 GPO Box 5219
 Brisbane QLD 4001
 T: +61 7 3177 4777

ARCHITECT
HDR

LANDSCAPE ARCHITECT
ARCADIA

Document Author Project Number
 24-1002



Site	Stage	NEXTDC Project Number
S5	REVISED SSDA	S5.00

Project Address
 269 LANE COVE ROAD,
 MAQUARIE PARK,
 SYDNEY, NSW 2113

Project Name
 NEXTDC DATA CENTRE

Drawing Title
 SOFTWARES PLAN 8

Drawing Status
 Development Application

Drawn	PM	Date	26/09/2025
Checked	SE	Date	26/09/2025
Approved	MB	Date	26/09/2025

Scale	Sheet	File Name
1 : 100	A1	SS-LAD-ALA-DRG-0-0101-L0408
Dwg no:		Rev
SS-LAD-ALA-DRG-0-0101-L0408		7

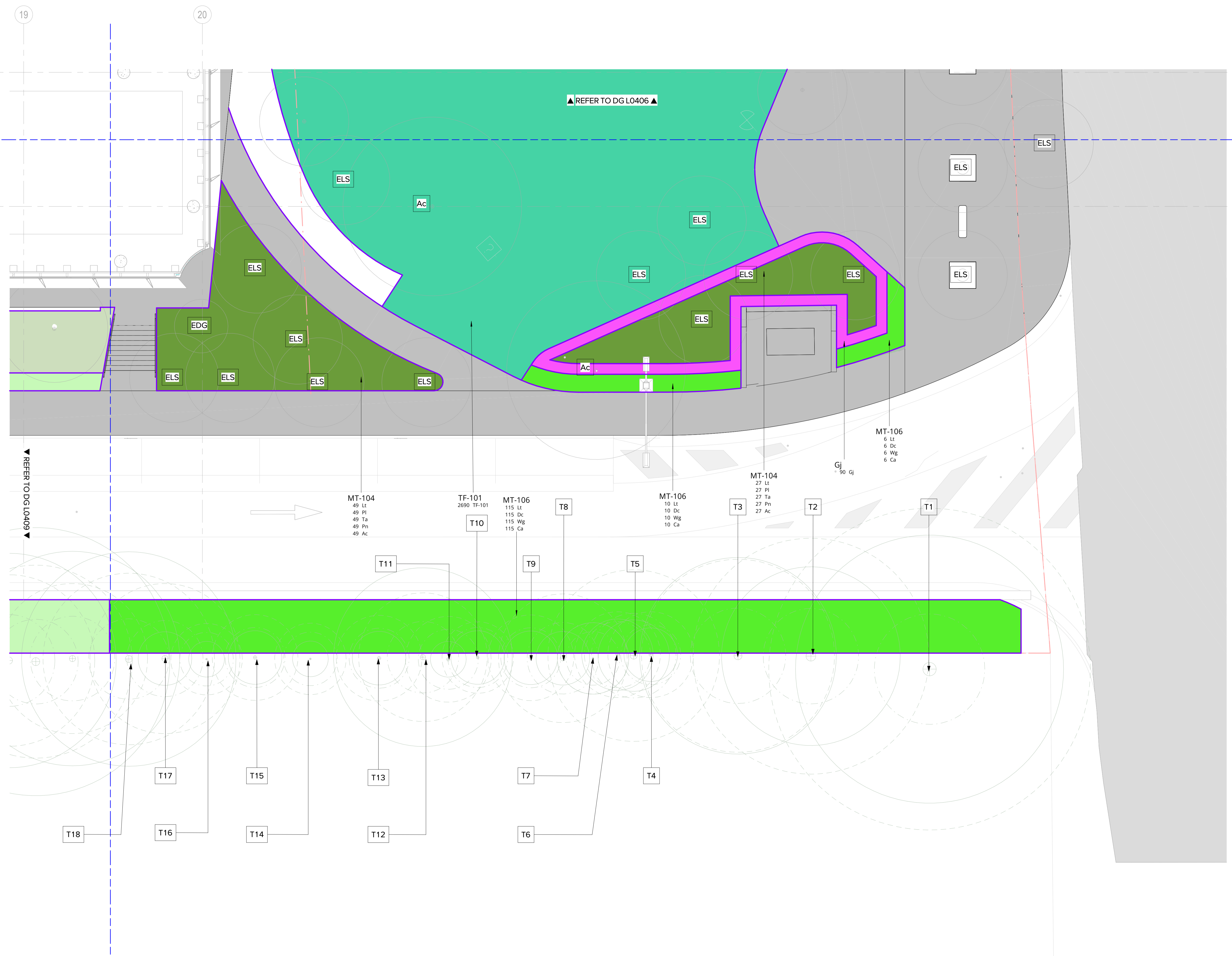

REFER TO DG L0409

REFER TO DG L0406

DATE	No.	REVISION HISTORY	DRW	CHK	QA
26/09/2025	7	SSDA	MM	MM	MM
21/09/2025	6	SSDA	MM	MM	MM
10/09/2025	5	SSDA	SE	MM	MM
11/09/2025	4	SSDA	SE	MM	MM
28/09/2024	3	SSDA	SE	MM	MM
30/09/2024	2	SSDA	SE	MM	MM
18/09/2024	1	SSDA	SE	MM	MM

- NOTE:
1. ALL DRAWINGS TO BE READ IN CONJUNCTION WITH ASSOCIATED SPECIFICATION
 2. DO NOT SCALE FROM DRAWINGS
 3. CONFIRM ALL MEASUREMENTS ON SITE
 4. CHECK ON SITE PRIOR TO CONSTRUCTION AND REPORT ANY DISCREPANCIES
 5. ENSURE COORDINATION WITH OTHER TRADES ON SITE

PRINCIPAL CONSULTANTS

Architect HDR

Services ARUP

Structural TTW

PRINCIPAL CONTRACTOR

Multiplex

CLIENT



NEXTDC

NEXTDC
GPO Box 3219
Brisbane QLD 4001
T: +61 7 3177 4777

ARCHITECT



LANDSCAPE ARCHITECT



Document Author Project Number

24-1002

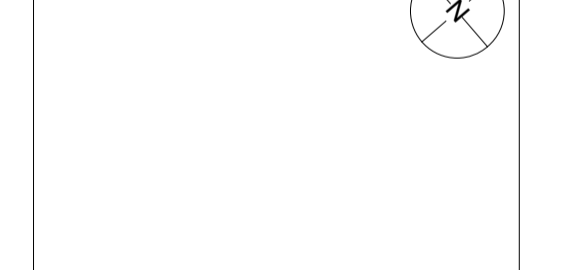

Site	Stage	NEXTDC Project Number
S5	REVISED SSDA	S5.00

Project Address

269 LANE COVE ROAD,
MAQUARIE PARK,
SYDNEY, NSW 2113

Project Name

NEXTDC DATA CENTRE

Drawing Title

SOFTWARES PLAN 10

Drawing Status

Development Application

Drawn	PM	Date	26/09/2025
Checked	SE	Date	26/09/2025
Approved	MB	Date	26/09/2025

Scale	Sheet	File Name
1 : 100	A1	SS-LAD-ALA-DRG-0-0101-L0410
Dwg no:	Rev	
SS-LAD-ALA-DRG-0-0101-L0410	7	

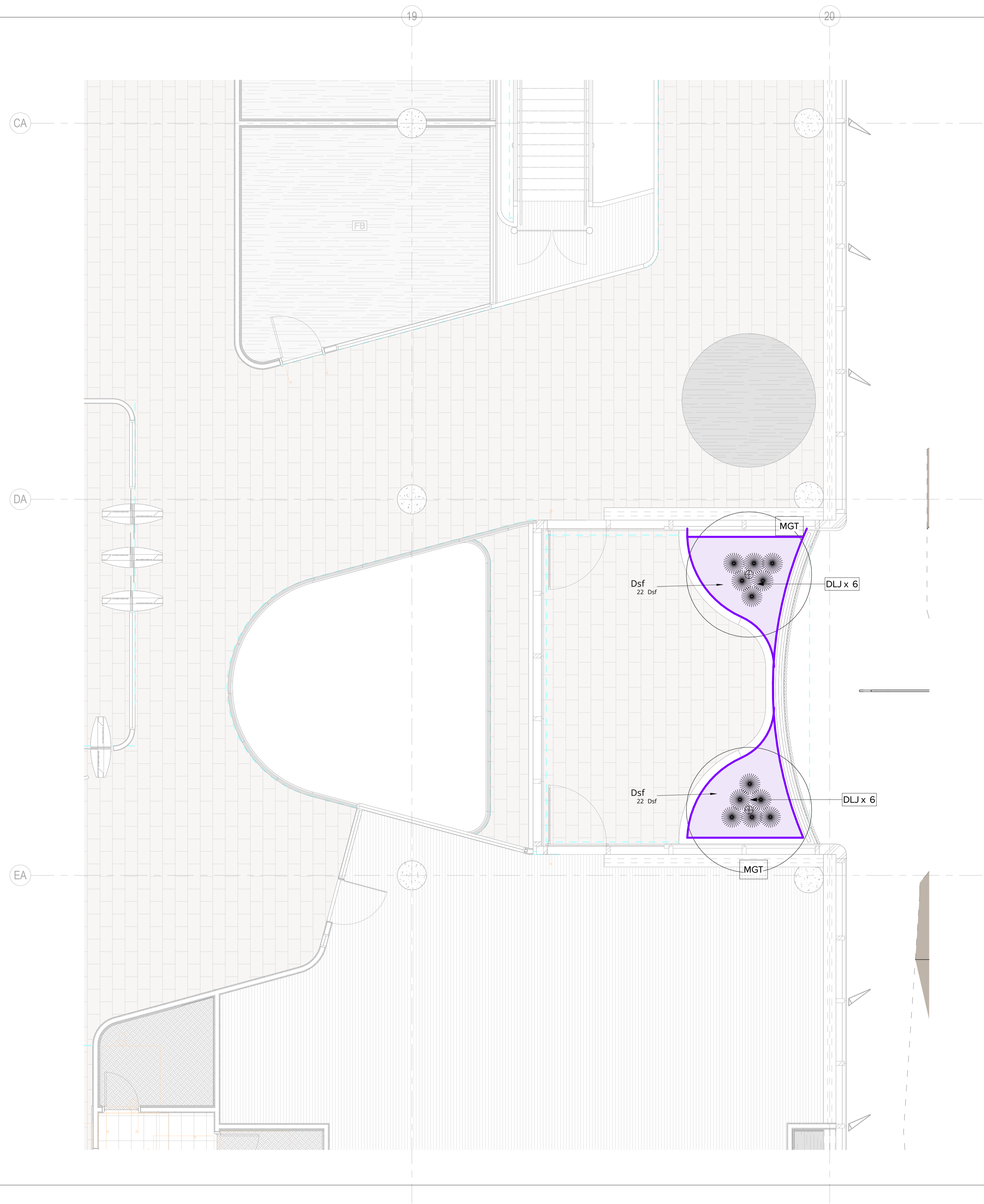

DATE	No.	REVISION HISTORY	DRW	CHK	QA
26/09/2025	7	SSDA		PMJ	MMI
31/03/2025	6	SSDA		MMI	MMI
19/03/2025	5	SSDA		SE	MMI
17/02/2025	4	SSDA		SE	MMI
28/10/2024	3	SSDA		SE	MMI
30/05/2024	2	SSDA		SE	MMI
16/04/2024	1	SSDA		SE	MMI

NOTE:
 1. ALL DRAWINGS TO BE READ IN CONJUNCTION WITH ASSOCIATED SPECIFICATION
 2. DO NOT SCALE FROM DRAWINGS
 3. CONFIRM ALL MEASUREMENTS ON SITE
 4. CHECK ON SITE PRIOR TO CONSTRUCTION AND REPORT ANY DISCREPANCIES
 5. ENSURE COORDINATION WITH OTHER TRADES ON SITE

PRINCIPAL CONSULTANTS
 Architect HDR
 Services ARUP
 Structural TTW

PRINCIPAL CONTRACTOR
Multiplex

CLIENT



NEXTDC
 NEXTDC
 GPO Box 3219
 Brisbane QLD 4001
 T +61 7 3177 4777

ARCHITECT



LANDSCAPE ARCHITECT

ARCADIA

Document Author Project Number
 24-1002

Key Plan

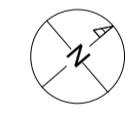

Site	Stage	NEXTDC Project Number
S5	REVISED SSDA	S5.00

Project Address
 269 LANE COVE ROAD,
 MAQUARIE PARK,
 SYDNEY, NSW 2113

Project Name
 NEXTDC DATA CENTRE

Drawing Title
 BLD O LVL 02, 04, 06, 08
 SOFTWARES PLAN 11

Drawing Status
 Development Application

DRAWN	SE	Date	26/09/2025
CHECKED	SE	Date	26/09/2025
APPROVED	MB	Date	26/09/2025

Scale	Sheet	File Name
1 : 50	A1	SS-LAD-ALA-DRG-G-0101-L0411
Dwg no:	Rev	
SS-LAD-ALA-DRG-G-0101-L0411	7	

Autodesk Docs://10314417_NEXTDC_S5_A02_2025/SS-LAD-ALA-DRG-G-0101-L0411.rvt

26/09/2025 3:04:09 PM

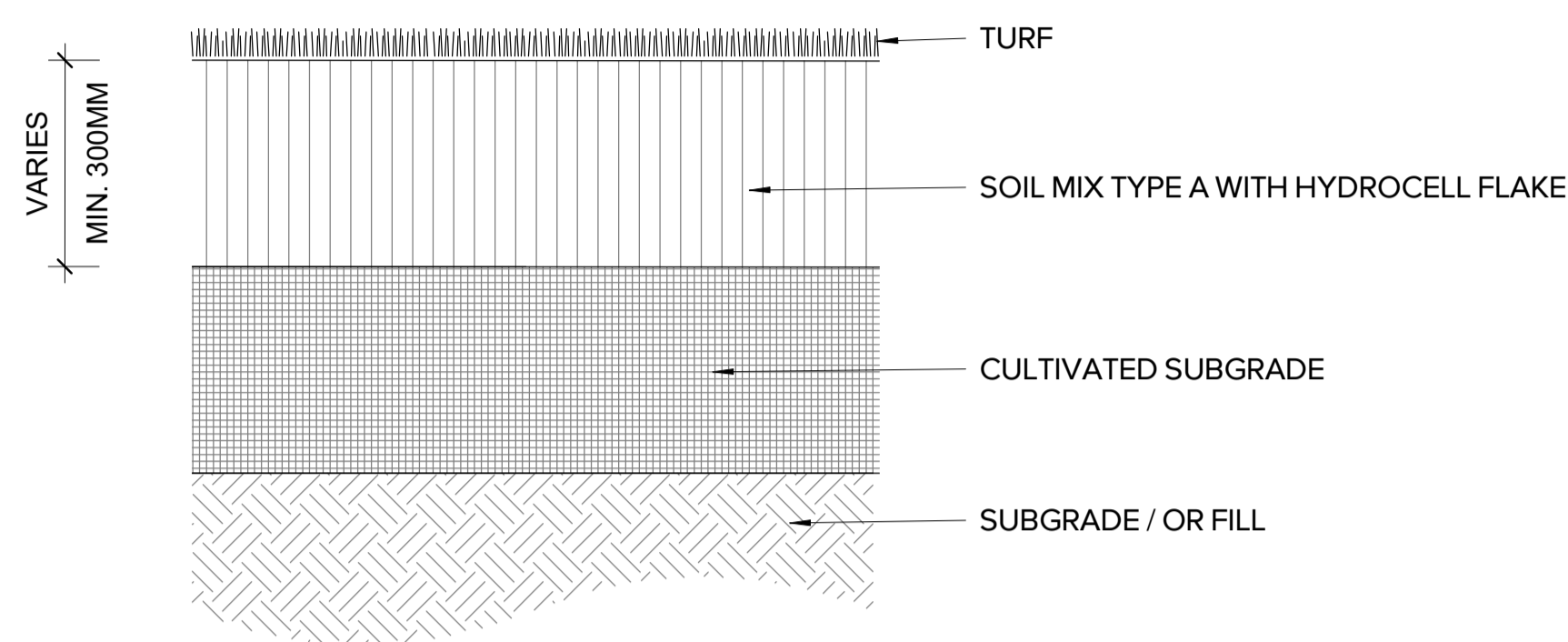

1 TURF - ON GRADE
1 : 10

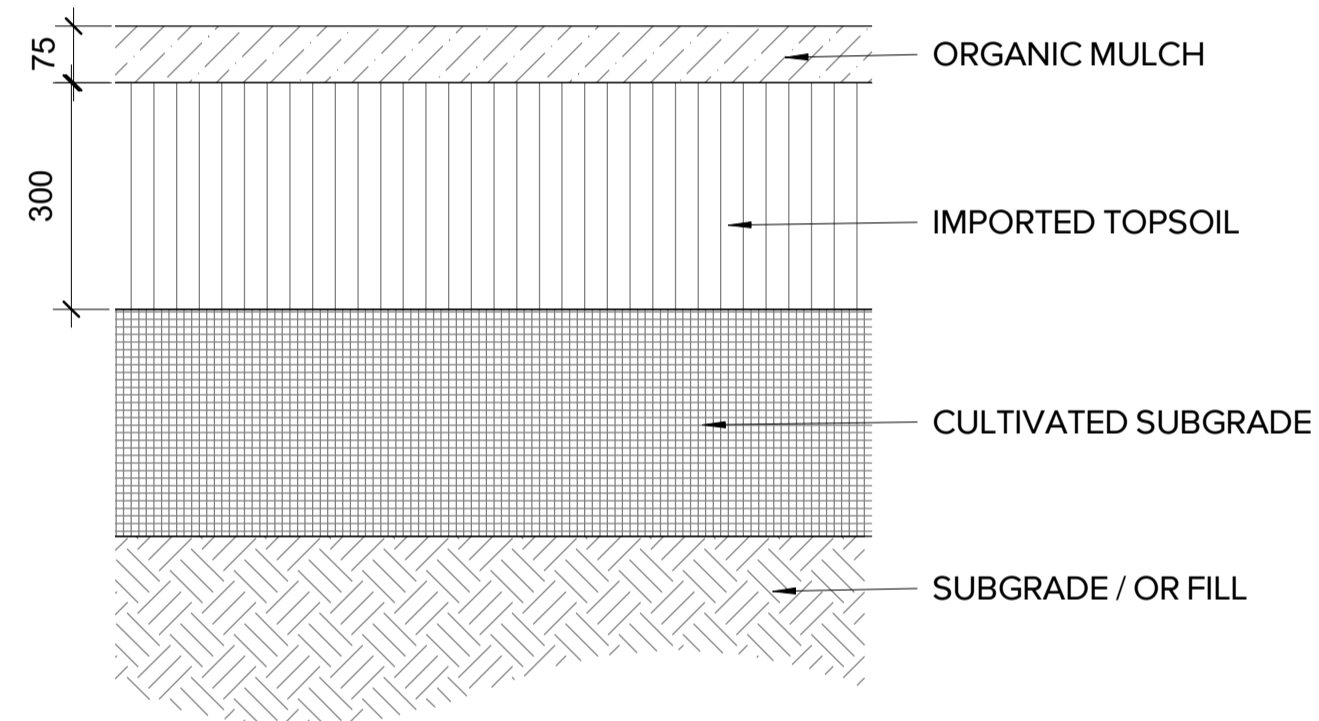

2 PLANTIG - ON GRADE
1 : 10

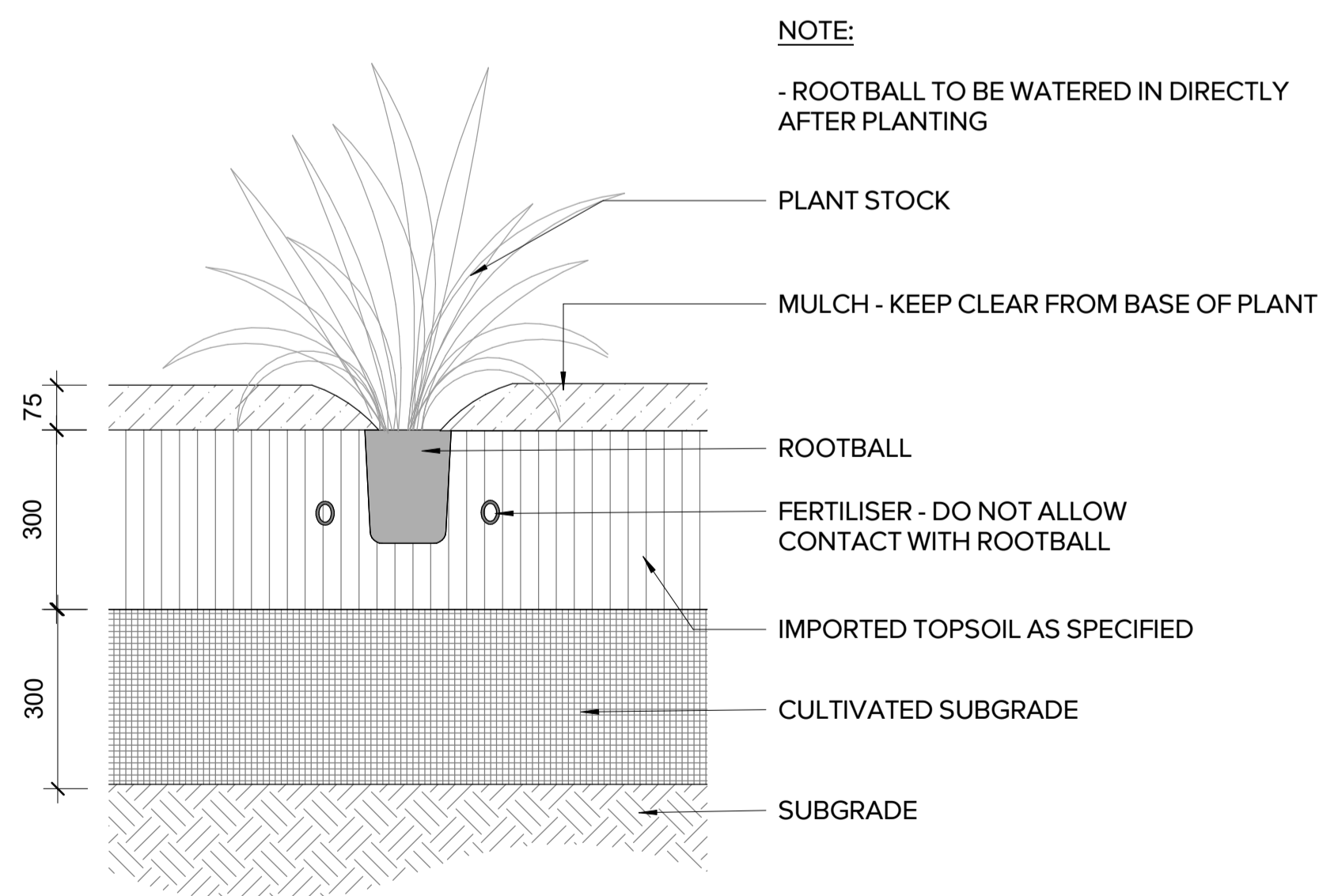

3 PLANTING - SHRUB
1 : 10

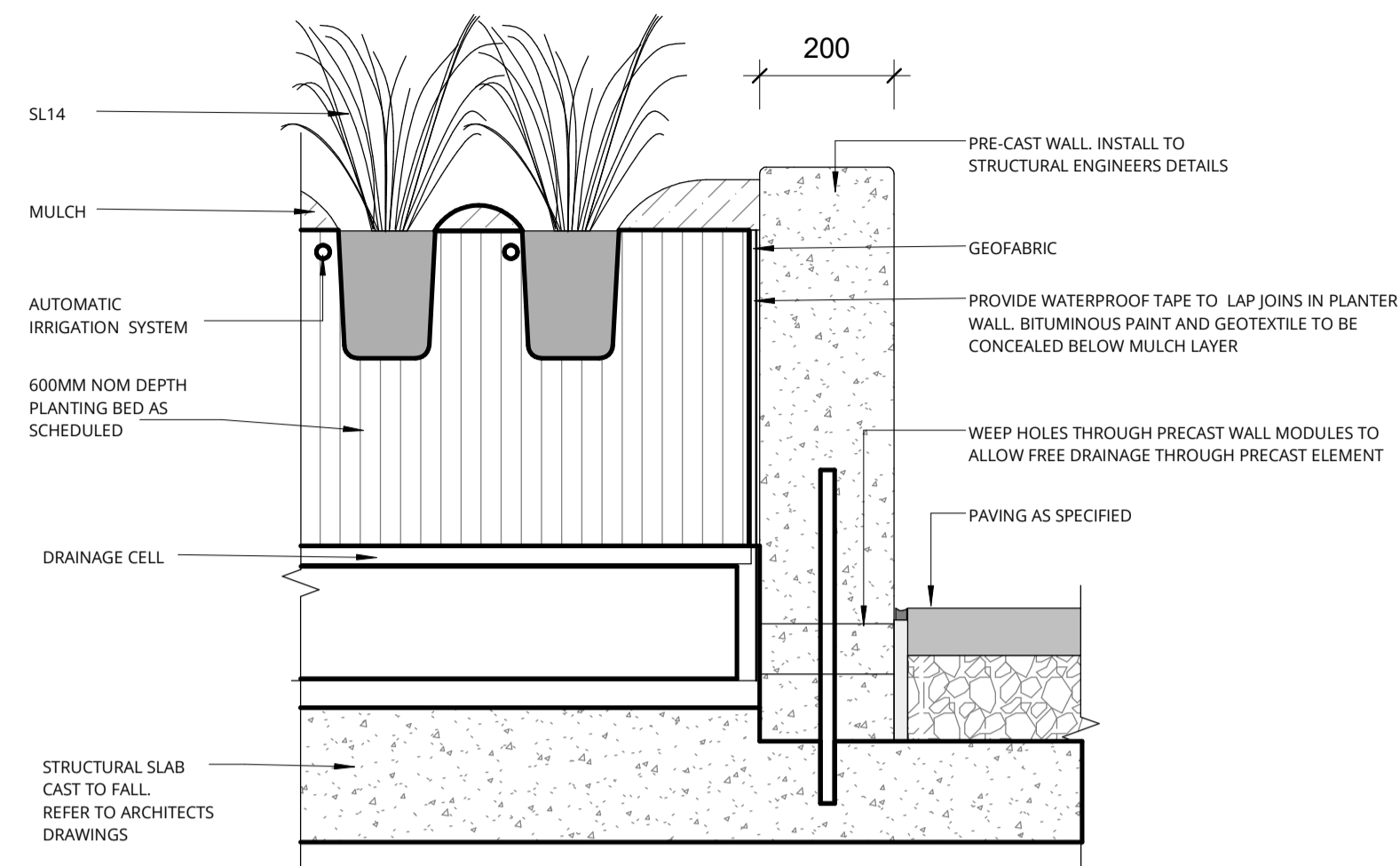

4 PLANTING - INSITU CONCRETE WALL
1 : 10

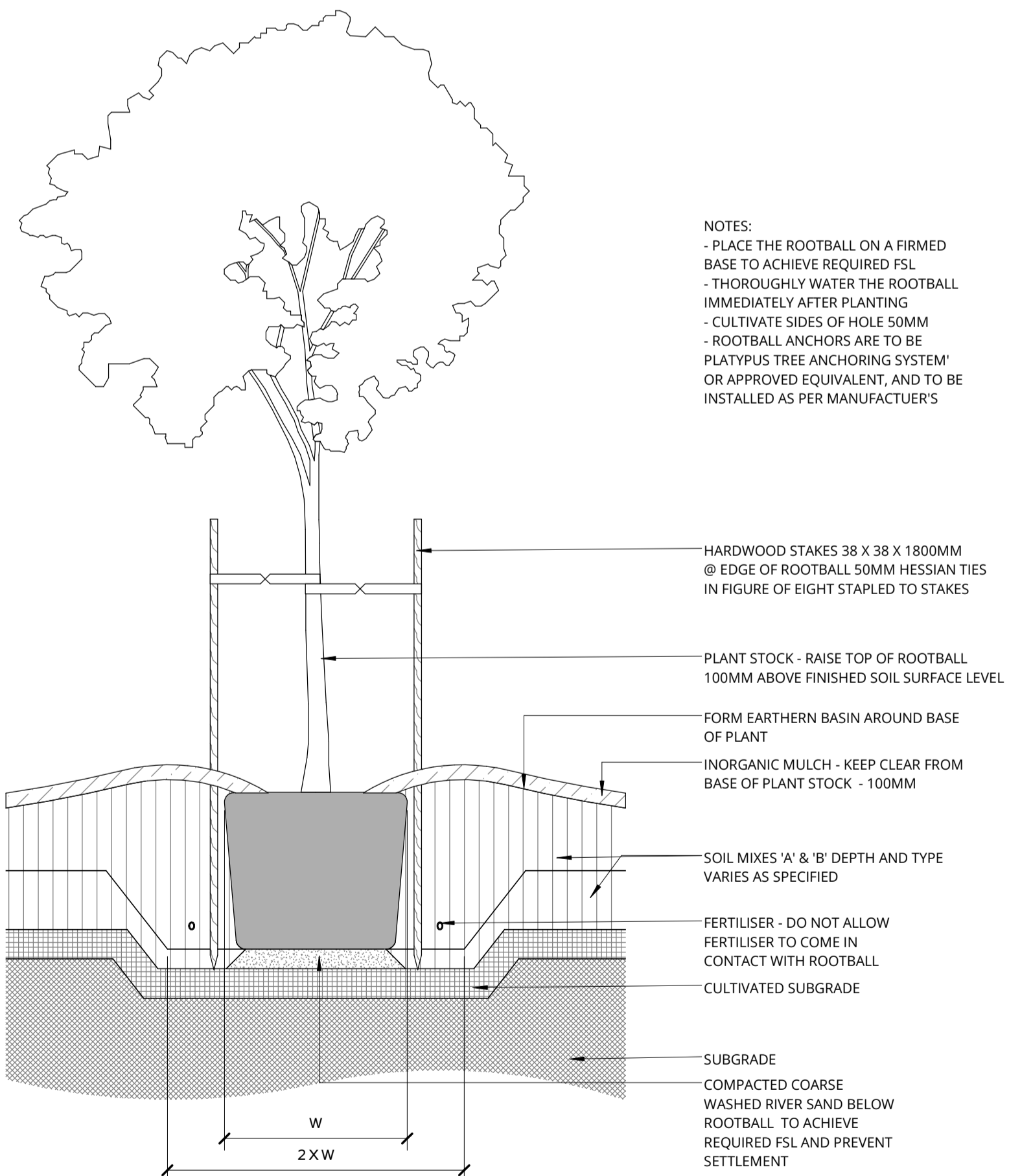

5 TREE - 400-1000L - TIMBER STAKES
1 : 25

DATE	No.	REVISION HISTORY	DRW	CHK	QA
26/09/2025	7	SSDA	PM	MM	
31/03/2025	6	SSDA	MM	MM	
10/03/2025	5	SSDA	SE	MM	
11/02/2025	4	SSDA	SE	MM	
28/10/2024	3	SSDA	SE	MM	
30/05/2024	2	SSDA	SE	MM	
18/04/2024	1	SSDA	SE	MM	

- NOTE:**
1. ALL DRAWINGS TO BE READ IN CONJUNCTION WITH ASSOCIATED SPECIFICATION
 2. DO NOT SCALE FROM DRAWINGS
 3. CONFIRM ALL MEASUREMENTS ON SITE
 4. CHECK ON SITE PRIOR TO CONSTRUCTION AND REPORT ANY DISCREPANCIES
 5. ENSURE COORDINATION WITH OTHER TRADES ON SITE

PRINCIPAL CONSULTANTS

Architect HDR

Services ARUP

Structural TTW

PRINCIPAL CONTRACTOR

Multiplex

CLIENT



NEXTDC
NEXTDC
GPO Box 3219
Brisbane QLD 4001
T: +61 7 3177 4777

ARCHITECT



LANDSCAPE ARCHITECT



Document Author Project Number

24-1002

Key Plan

Site	Stage	REVISID	NEXTDC Project Number
S5	SSDA	SSDA	S5.00

Project Address

269 LANE COVE ROAD,
MAQUARIE PARK,
SYDNEY, NSW 2113

Project Name

NEXTDC DATA CENTRE

Drawing Title

LANDSCAPE DETAILS

Drawing Status

Development Application

Drawn	PM	Date
PM	26/09/2025	
Checked	SE	Date
SE	26/09/2025	
Approved	MB	Date
MB	26/09/2025	

Scale Sheet File Name

As indicated A1 SS-LAD-ALA-DRG-0-0101-L0601

Dwg no: Rev

SS-LAD-ALA-DRG-0-0101-L0601 7