



269 Lane Cove Road, Macquarie Park Construction Traffic Management Plan

Prepared for:
NEXTDC Limited

22 May 2024

The Transport Planning Partnership

269 Lane Cove Road, Macquarie Park Construction Traffic Management Plan

Client: NEXTDC

Limited Version: V05

Date: 22 May 2024

TPP Reference: 23217

Quality Record

Version	Date	Prepared by	Reviewed by	Approved by	Signature
V01	21/02/2024	Ashwini Uthishtran	Jessica Ng	Ken Hollyoak	Ken Hollyoak
V02	05/04/24	Ashwini Uthishtran	Jessica Ng	Ken Hollyoak	Ken Hollyoak
V03	09/04/24	Ashwini Uthishtran	Jessica Ng	Ken Hollyoak	Ken Hollyoak
V04	18/04/24	Ashwini Uthishtran	Jessica Ng	Ken Hollyoak	Ken Hollyoak
V05	22/05/24	Ashwini Uthishtran	Ken Hollyoak	Ken Hollyoak	

Table of Contents

1	Executive Summary	1
2	Introduction	3
	2.1 Author Credentials	3
	2.2 Project Description	3
	2.3 Secretary's Environmental Assessment Requirements	5
	2.4 Purpose of this CTMP	6
3	Existing Conditions	7
	3.1 Site Description	7
	3.2 Road Network Description	7
	3.3 Public Transport Facilities	8
	3.4 Pedestrian and Cycling Facilities.....	11
4	Proposed Construction Activities	12
	4.1 Description of Construction Activities	12
	4.2 Duration and Staging Works.....	12
	4.3 Work Hours	13
	4.4 Site Access Arrangements and Vehicle Types	13
	4.5 Vehicle Movement Plan	14
	4.6 Construction Worker Parking.....	15
	4.7 Materials and Handling Area	15
	4.8 Road Occupancy License Requirements	15
	4.9 Work Zone Requirements.....	15
5	Construction Traffic Assessment and Implications.....	16
	5.1 Construction Traffic Generation	16
	5.2 Pedestrian and Cycle Access.....	16
	5.3 Public Transport Facilities	17
	5.4 Emergency Vehicles and Heavy Vehicles	17
	5.5 Adjoining Properties and Local Access	17
6	Construction Traffic Management Measures.....	18
	6.1 Traffic Guidance Scheme	18
	6.2 Vehicle Access	18
	6.3 Truck Routes	18
	6.4 Heavy Vehicle Loads	19
	6.5 Construction Worker Parking.....	19

6.6	Site Inspections and Record Keeping	19
6.7	Worker Induction Training	20
6.8	Contingency Plans	20
6.9	Liaison with Stakeholders	21
7	Conclusion	22

Tables

Table 1.1:	Indicative Construction Program	1
Table 2.1:	Summary of Author Credentials	3
Table 2.2:	Review of Compliance with SEARs.....	5
Table 3.1:	Available Bus Services and Associated Frequencies.....	9
Table 4.1:	Indicative Construction Program	13
Table 5.1:	Summary of Construction Traffic Movements.....	16
Table 6.1:	Emergency Authorities.....	20
Table 6.2:	Contingency Plans	21

Figures

Figure 3.1:	Site Location.....	7
Figure 3.2:	Public Transport Network Surrounding the Subject Site	8
Figure 3.3:	Local Bus Network Map	10
Figure 3.4:	Surrounding Cycling Infrastructure	11
Figure 4.1:	Construction Vehicle Routes.....	14

APPENDICES

- A. SWEPT PATH ASSESSMENT
- B. TRAFFIC GUIDANCE SCHEME (TGS)

1 Executive Summary

This Construction Traffic Management Plan (CTMP) has been prepared by The Transport Planning Partnership (TPPP) on behalf of NEXTDC Limited to accompany a detailed State Significant Development Application (SSDA) for the S5 data centre development at 269 Lane Cove Rd, Macquarie Park.

The legal description of the site is Lot 3 in Deposited Plan (DP) 1129811.

This report has been prepared to address the Secretary's Environmental Assessment Requirements (SEARs) issued for the project (SSD-63168959).

Multiplex has been appointed as Head Contractor for the works and they have provided the indicative construction staging and associated construction vehicle generation which is summarised in Table 1.1.

The staging of these construction works periods may change subject to further consultation with stakeholders/detailed construction planning. There may also be some overlapping of construction stages / building works between buildings.

Table 1.1: Indicative Construction Program

Construction Activities	Duration (months)	Daily Two-Way Movements	Hourly Two-Way Movements
Demolition	3 months	20 trips per day	Up to 2
Excavation and Site Preparation	3 months	10 trips per day	Up to 1
Construction and Building Works (Building A)	22 months	40 trips per day	Up to 4
Construction and Building Works (Building B)	14 months	40 trips per day	Up to 4
Public Domain Works (This is concurrent with the Building A construction and building works)	3 months	20 trips per day	Up to 2
Total	Building A - 28 months Building B - 14 months	-	-

The majority of trucks associated with the construction activities are expected to be carried out by 8.8m long medium rigid vehicles (MRV) or 12.5m long heavy rigid vehicles (HRV), with site access provided directly off Waterloo Road via the internal road.

Appropriate traffic management shall be in place to manage the construction traffic impacts of the development, including dedicated site personnel assigned on-site to manage and assist construction vehicle movements associated with the proposed construction works. Site personnel will also manage pedestrians crossing the site access on Waterloo Road.

In summary, this report concludes that the proposed construction activities associated with the data centre development shall be appropriately managed to minimise its impacts during construction. Any changes proposed by Multiplex will require an updated CTMP to be prepared and/or amended for further review and/or approval from the relevant consent authorities.

2 Introduction

This report has been prepared to accompany a detailed SSDA for the proposed S5 data centre development at 269 Lane Cove Road, Macquarie Park (SSD-63168959).

2.1 Author Credentials

Table 2.1 provides a summary of the Author Credentials.

Table 2.1: Summary of Author Credentials

Name	Qualifications	Professional Overview
Ken Hollyoak, Director	FIEAust CPEng NER APEC Engineer IntPE (Aus) RPEQ FAITPM MICE FICHT Eur Ing BSc (Hons) MSc (Dist)	Ken is a chartered professional engineer and has over 40 years of experience in the road design/ transportation & traffic planning field. He primarily works as traffic advisor preparing transport impact assessments for development applications / planning proposals as part of multidisciplinary development teams.
Jessica Ng, Associate	BE Civil (Hons)	Jessica has 10 years of experience in traffic and transportation engineering in both public and private sectors. Jessica is experienced in assessing traffic, transport and parking impacts through her involvement in various small to large scale developments.
Ashwini Uthishtran, Traffic Engineer	BE Civil (Hons) / B Com	Ashwini has five years of experience with working on various projects. She also has experience with working on traffic impact assessments (TIA), construction traffic management planning (CTMP) and SIDRA Intersection modelling.

2.2 Project Description

The application seeks consent for construction and operation of a data centre development and includes site preparation works, bulk earthworks and infrastructure, and construction of the buildings, ancillary facilities, and associated site works. The application also includes the delivery of two internal roads and an urban plaza adjacent to the Macquarie Park Metro Station entrance.

Specifically, the Project comprises the redevelopment of the site as summarised below:

The application seeks consent for construction and operation of a data centre development and includes site preparation works, bulk earthworks and infrastructure, and construction of the buildings, ancillary facilities, and associated site works. The application also includes the delivery of two internal roads and an urban plaza adjacent to the Macquarie Park Metro Station entrance.

Specifically, the Project comprises the redevelopment of the site as summarised below:

- Site preparation works including demolition and removal of existing structures, tree removal and bulk earthworks.

- Staged construction and operation of two data centre buildings (Building A and Building B), each with a maximum height of 65 metres and a combined total gross floor area (GFA) of 46,935m² comprising 33,643m² of technical data hall floor space and 13,292m² of office, retail and innovation hub floor space.
- Building A will be delivered in Stage 1, comprising:
 - Basement parking for 105 cars including four accessible spaces and 10 EV spaces.
 - Two retail tenancies at ground level: 335m².
 - Lobby and innovation hub including auditorium and training rooms: 3,192m².
 - NEXTDC and mission critical (MCX) office floor space: 9,765m².
 - Seven storeys of technical data floor space accommodating seven data houses: 17,258m²
 - Utilities including diesel generators (2MWe), above-ground water tanks for industrial water (460kL each), above-ground diesel storage tanks (110kL each) and an above-ground water tank for fire water (350kL each).
 - Business identification signage facing Waterloo Road and Lane Cove Road.
- Building B will be delivered in Stage 2, comprising:
 - Seven storeys of technical data floor space accommodating seven data halls: 16,385m².
 - Construction of a sky bridge which will connect with Building A, providing direct access between the data halls.
 - Utilities including diesel generators (2MWe), above-ground water tanks for industrial water (460kL each), above-ground diesel storage tanks (110kL each) and an above-ground water tank for fire water (350kL each).
 - Business identification signage on the western and southern building facades.
- Landscaping across the site in accordance with the project staging, delivering a mix of native and endemic plant species, shrubs and grasses, including 93 additional trees within a total area of 4,835m² deep soil and a resultant tree canopy cover of 6,211m².
- Staged delivery of public domain works, including:
 - Stage 1: construction of the northern extent of Road 13 from Waterloo Road and urban plaza between Building A and Waterloo Road.
 - Stage 2: construction of the remaining southern extent of Road 13 and the full extent of Road 5.
- Delivery of 90 megawatts of power (via a separate application with Ausgrid) with a 33kV switching station to be accommodated on site, as well as other site services, including stormwater infrastructure.

2.3 Secretary's Environmental Assessment Requirements

This report has been prepared in response to the requirements contained within the Secretary's Environmental Assessment Requirements (SEARs) dated 8 November 2023 issued for the SSDA (SSD-63168959). Specifically, this report has been prepared to respond to the SEARS requirement as shown in Table 2.2.

Table 2.2: Review of Compliance with SEARs

Secretary's Environmental Assessment Requirements	Addressed in
<p>Traffic and Transport – a quantitative traffic impact assessment prepared in accordance with relevant Roads and Maritime Services and Austroads guidelines, that includes:</p>	<p>This Plan has been prepared to address the construction impacts associated with the Proposal. The traffic impacts associated with the site during operation are addressed separately in TTPP's Traffic and Transport Assessment Report dated 9 April 2024 (Ref: 23217-R02V05-240418-TIA).</p>
<ul style="list-style-type: none"> ▪ details of all traffic types and volumes likely to be generated during construction and operation, including a description of key access / haul routes, breakdown of traffic generation for the different uses on the site, vehicle type and transportation mode (light and heavy vehicles, public transport, pedestrian and cycle trips) 	<p>Section 4 and 5 includes details of traffic types and volumes during construction, including proposed access routes.</p>
<p>an assessment of:</p> <ul style="list-style-type: none"> ▪ the predicted impacts of this traffic on the capacity of the road network, including consideration of cumulative traffic impacts on existing performance levels of nearby intersections, using a calibrated SIDRA (or similar) traffic model 	<p>This traffic impacts during constructions are assessed in Section 5.1. The proposed construction is anticipated to generate a modest level of traffic, up to 8 construction vehicle movements per hour during peak construction activities. This level of traffic is low and could not be expected to result in any adverse impact on the surrounding road network. Therefore, no SIDRA traffic models are considered required.</p>
<ul style="list-style-type: none"> ▪ the adequacy of existing public and active transport or any future transport infrastructure within the vicinity of the site to accommodate the likely future demand of the proposed development 	<p>This impacts of the proposed construction on existing public and active transport is detailed in Section 5. Existing public and active transport will be maintained around the work site as per existing conditions during construction.</p>
<ul style="list-style-type: none"> ▪ road and pedestrian safety adjacent to the proposed development <ul style="list-style-type: none"> ○ plans demonstrating how all vehicles likely to be generated during construction and operation and awaiting loading, unloading or servicing can be accommodated on the site to avoid queuing in the street network 	<p>The construction traffic implications are detailed in Section 5. The construction traffic management measures are detailed in Section 6. All loading and unloading during construction would be undertaken wholly within the site.</p>
<ul style="list-style-type: none"> ○ details and plans of the proposed internal road network, emergency access, loading docks, pedestrian and cycling facilities and on-site parking (including a detailed breakdown for all uses on the site) in accordance with the relevant Australian Standards 	<p>The construction traffic management measures are detailed in Section 6.</p>
<ul style="list-style-type: none"> ○ details of the largest vehicle anticipated to access and move within the site, including swept path diagrams depicting vehicles entering, exiting and manoeuvring throughout the site 	<p>This is detailed in Section 4.4. The largest vehicle anticipated to access and move within the site during construction would be a 12.5m long heavy rigid vehicle. It may be necessary to use a 19m articulated vehicle to deliver large plant / equipment during "one-</p>

Secretary's Environmental Assessment Requirements	Addressed in
	off" occasions, which would be subject to a separate approval. Swept path diagrams using a 12.5m HRV and 19m articulated vehicle are provided in Appendix A.
<ul style="list-style-type: none"> o details of operational measures to integrate the development with the existing/future public transport network 	N/A – this CTMP relates to construction only, not operational measures.
<ul style="list-style-type: none"> o details of road upgrades, infrastructure works or new roads or access points required for the development if necessary. 	N/A – this CTMP relates to construction only. There will be a new road built as part of construction works, but this would only be open once construction finishes.

Multiplex has been appointed as Head Contractor for the works. Any changes proposed by Multiplex will require an updated CTMP to be prepared and/or amended for further review and/or approval from the relevant consent authorities.

2.4 Purpose of this CTMP

The purpose of this CTMP is to describe how vehicular, cyclist and pedestrian movements will be managed during the proposed construction works. This CTMP provides a structured approach to manage traffic and access during this stage to provide a safe road environment, minimise impacts on the surrounding road network, while maintaining access for all road users and the local community.

Specifically, the purpose of this CTMP is to:

- Maintain access to/ from adjacent properties.
- Restrict construction vehicle movements to designated routes to/ from the site.
- Manage and control construction vehicle activity in the immediate area of the site.
- Provide an appropriate, convenient and safe environment for pedestrians and cyclists.
- Minimise the impact on pedestrian and cyclist movements.
- Maintain appropriate capacity for pedestrians on the footpath adjacent to the site.
- Maintain appropriate public transport access.
- All construction activity would be carried out in accordance with approved hours of work.

This CTMP has been prepared and checked by engineers who hold the *SafeWork NSW Traffic Control Work Training Card*.

3 Existing Conditions

3.1 Site Description

The subject site is located at 269 Lane Cove Road, Macquarie Park and falls within City of Ryde Local Government Area. The site area is bound by Lane Cove Road to the west, Waterloo Road to the north and industrial developments to the south and east.

The existing site comprises of a two-storey office furniture store called Work Arena at the north end of the site and offices and studios associated with Foxtel in the southern part of the site.

Vehicle access is currently provided off Waterloo Road with an internal driveway providing access car parking areas. There is also a vehicle crossover at Lane Cove Road which is not in use with barriers preventing access.

The site location and its surrounds are shown in Figure .

Figure 3.1: Site Location

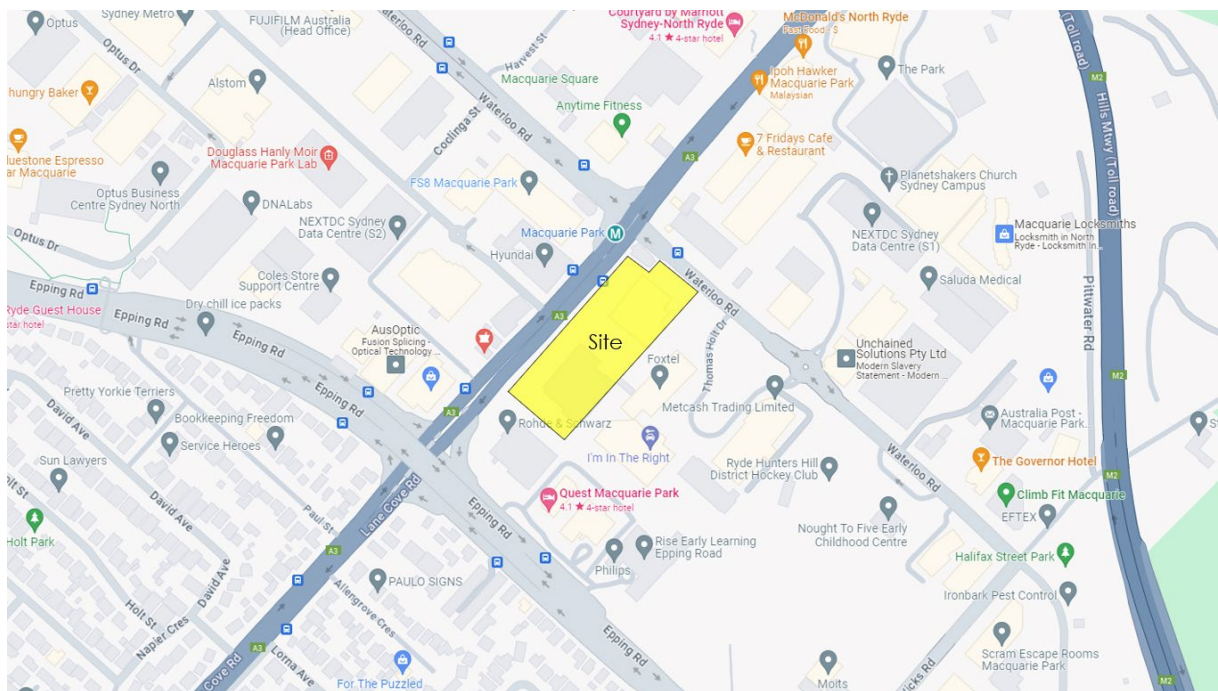

3.2 Road Network Description

Lane Cove Road is a classified State Road and forms one of the major north-south arterial links in the northern/ north-western suburbs. The road provides good connectivity to the wider arterial road network, notably to Ryde Road, M2 Motorway, Victoria Road and Devlin Street. Within the vicinity of the site, Lane Cove Road runs in a north-east to south-west direction. The

road provides three through traffic lanes in each direction separated by a central median. The road has a posted speed limit of 70 km/h in both directions within the vicinity of the site.

Epping Road is a classified State Road and connects to Blaxland Road in the west and Longueville Road in the east. The road provides three through traffic lanes in each direction separated by a central median. The road has a posted speed limit of 70 km/h in both directions within the vicinity of the site.

Waterloo Road is a local road which connects to Wicks Road in the south and University Avenue in the north. The road provides one through traffic lane in each direction. The site will be accessed via the existing site access provided off Waterloo Road.

3.3 Public Transport Facilities

The site is well serviced by a network of public transport services, including train, metro and bus services being located within 100-metres from the Macquarie Park Metro Station and bus routes along Lane Cove Road, Waterloo Road and Epping Road.

The subject site proximity to public transport services is shown in Figure .

Figure 3.2: Public Transport Network Surrounding the Subject Site



Table 3.1: Available Bus Services and Associated Frequencies

Route Number	Route Name	Distance from Subject Site (m)	Service Frequency
197	Mona Vale to Macquarie University	170m (Waterloo Road)	Peak: 15 minutes Off-peak: 30 minutes
259	Macquarie Centre to Chatswood	Site frontage (Lane Cove Road)	Peak: 15 minutes Off-peak: 30 minutes
292	Marsfield to City Erskine Street		Peak: 5 – 15 minutes Off-peak: 30 minutes
294	Macquarie University to City Wynyard		Peak: 15 minutes Off-peak: No services
410	Macquarie Park to Hurstville		Peak: 10 minutes Off-peak: 15 minutes
506	Macquarie University to City Domain		Peak: 5 - 15 minutes Off-peak: 30 minutes
545	Parramatta to Macquarie Park		Site frontage (Waterloo Road)
550	Parramatta to Macquarie Park	Peak: 10 minutes Off-peak: 15 – 30 minutes	
562	Gordon to Macquarie University	550m (Talavera Road)	Peak: 1 hour Off-peak: No service
565	Chatswood to Macquarie University		Peak: 10 - 30 minutes Off-peak: 1 hour
572	Turramurra to Macquarie University		Peak: 15 minutes Off-peak: 30 minutes
575	Hornsby to Macquarie University		Peak: 20 minutes Off-peak: 30 minutes
611	Blacktown to Macquarie Park	Site frontage (Waterloo Road)	Peak: 5 – 15 minutes Off-peak: 15 - 30 minutes
619	Castle Hill to Macquarie Park		Peak: 15 – 20 minutes Off-peak: No service

Source: TfNSW

3.4 Pedestrian and Cycling Facilities

Well-established pedestrian infrastructure is provided within the vicinity of the site. Sealed pedestrian footpaths are provided on Lane Cove Road whereas shared paths between pedestrians and cyclists are provided on Waterloo Road and Epping Road. These footpaths provide pedestrian connection to Macquarie University and Macquarie Park metro stations as well as the surrounding bus stops.

Dedicated pedestrian facilities are provided on three of the four approaches at the intersection between Waterloo Road and Lane Cove Road in the form of signalised crossings or zebra crossing. Pedestrian may use these facilities to safely cross the road.

The site is surrounded by cycling infrastructure, with shared pedestrian and cyclist paths provided on Waterloo Road, Talavera Road and Epping Road as shown in Figure . These shared paths provide good cycling connection to surrounding areas, including commercial offices, retail shops and the shopping centre within Macquarie Park, as well as the surrounding public transport network.

Figure 3.4: Surrounding Cycling Infrastructure

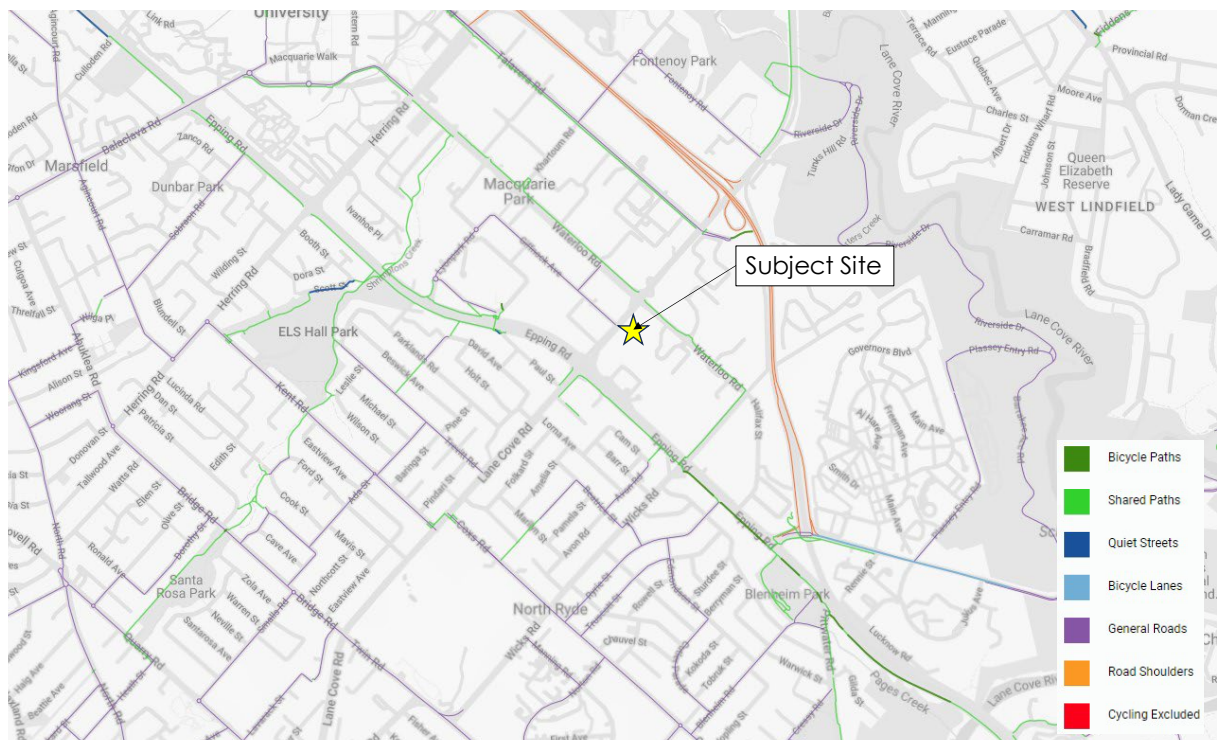

Source: TfNSW – last accessed on 08/01/2024.

4 Proposed Construction Activities

4.1 Description of Construction Activities

The Project includes demolition of existing buildings and hardstand areas, site preparation works, removal of trees and the construction and operation a data centre comprising:

- Demolition of existing buildings and structures.
- Site preparation works including tree removal, bulk earthworks, excavation and construction of retaining walls.
- Staged construction of two data centre buildings including technical data hall floor space, ancillary office and innovation space and two ground floor retail premises.
- Vehicle access via Waterloo Road with on-site car parking and loading within basement.
- Associated landscaping including a trees, shrubs and grasses.
- Business identification signage.
- Staged delivery of public domain works via a Planning Agreement, including construction of Road 5 and Road 13 and an urban plaza between Building A and Waterloo Road.
- Provision of required utilities, including an on-site switching station.

The extent of the work site shall be wholly contained within the site boundary, with minimal impact on the surrounding road network.

4.2 Duration and Staging Works

The construction is expected to occur for a total period of 18 months for each building.

The indicative construction staging and estimated duration of construction is summarised in Table 4.1.

The staging of these construction works periods may change subject to further consultation with stakeholders/detailed construction planning. Furthermore, there may be some overlapping of construction activities between both buildings (e.g. demolition and excavation stages may occur at the same time for both buildings).

Table 4.1: Indicative Construction Program

Construction Activities	Duration (months)
Demolition	3 months
Excavation and Site Preparation	3 months
Construction and Building Works (Building A)	22 months
Construction and Building Works (Building B)	14 months
Public Domain Works (This is concurrent with the Building A construction and building works)	3 months
Total	Building A - 28 months Building B - 14 months

4.3 Work Hours

Planning approval for the proposed development has not been granted. However, it is expected that the approval will stipulate working hours for construction works. At this stage, it is envisaged that the standard construction work hours will be as follows:

- Monday to Friday: 7:00am-5:00pm
- Saturday: 8:00am-1:00pm
- Sunday and Public Holidays: No works

Any works outside these times will only occur with approval from the relevant authorities (i.e. City of Ryde Council and Transport for NSW), prior to the commencement of any works. Such works may include delivery of cranes, large plant or equipment required for the site. Multiplex will be responsible to liaise with Council to obtain all relevant permit approvals.

4.4 Site Access Arrangements and Vehicle Types

Access to the site will be provided off Waterloo Road via the internal road, which only services the site (i.e. no other buildings have access off the internal road).

Construction vehicles likely to be generated by the construction activities include:

- small to heavy rigid vehicles, vans and couriers for smaller deliveries, and
- concrete pumps and concrete trucks to facilitate construction works.

The majority of trucks associated with the construction activities are expected to be carried out by 8.8m long medium rigid vehicles (MRV) or 12.5m long heavy rigid vehicles (HRV). Swept path analysis has been conducted using a 12.5m long HRV and is provided in Appendix A.

In addition to this, it may be necessary that a 19m long articulated vehicle would be required to deliver large plant and equipment to/from the works site. TPP has undertaken swept path analysis using a 19m long articulated vehicle, which is enclosed in Appendix A. It is however noted that Multiplex will be responsible for obtaining all relevant permits and/or approvals with relevant authorities to use a 19m long articulated vehicle for these “one-off” occasions.

4.5 Vehicle Movement Plan

Construction vehicles will have origins and destinations throughout Sydney. Dedicated construction vehicle routes have been developed to provide the shortest distances to/from the arterial road network, whilst minimising the impact of construction traffic on streets within the immediate vicinity of the site.

Construction vehicle access to the works site shall be provided off Waterloo Road, via the internal road to the site. All truck drivers will be advised of the designated truck routes to/from the site and be required to adhere to the nominated routes.

The designated truck routes to/from the site are shown in Figure 4.1.

Figure 4.1: Construction Vehicle Routes

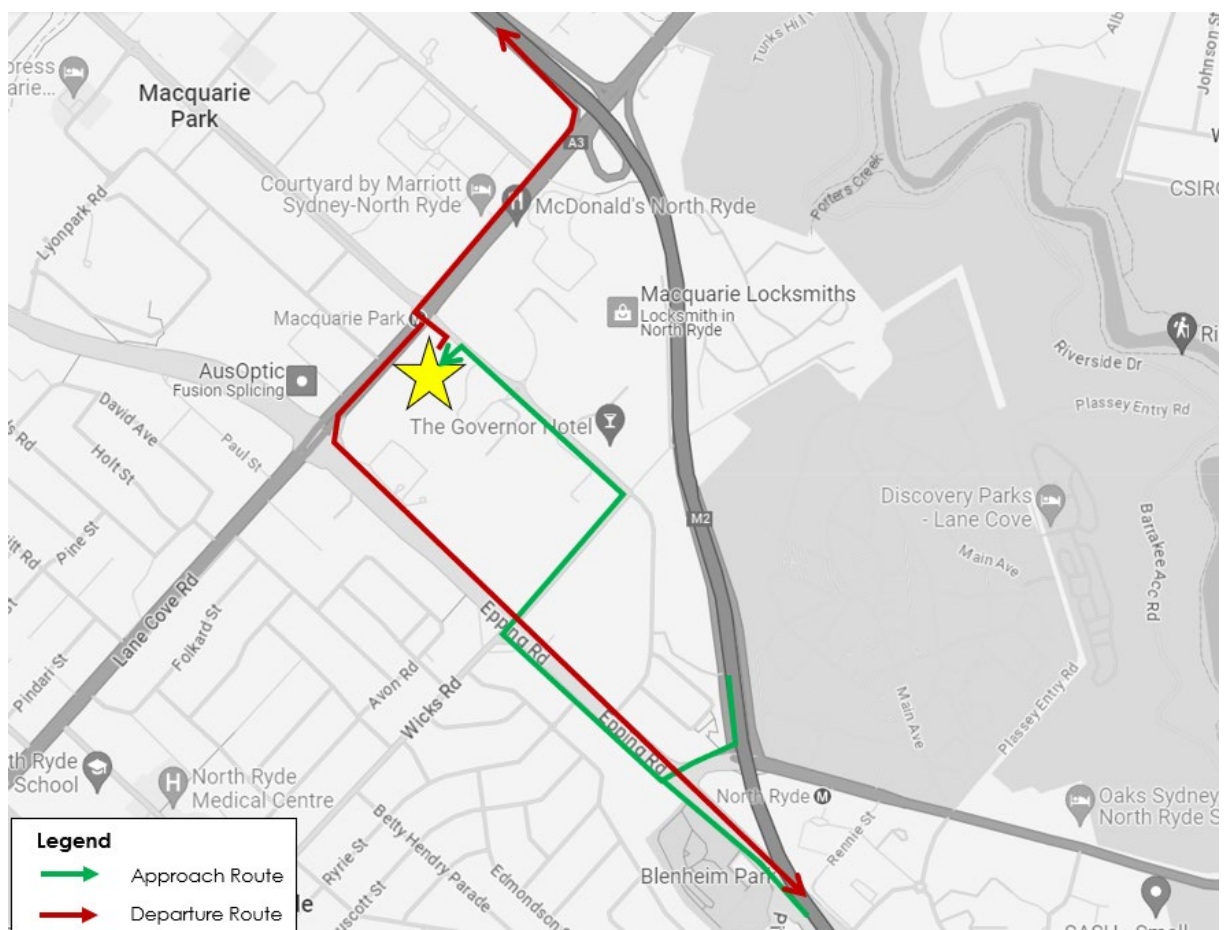

4.6 Construction Worker Parking

Limited on-site vehicle parking will be provided during construction. All workers will however be encouraged and expected to use public transport and/or carpool to travel to/from the site. This will be incorporated in the workers induction program to ensure minimal parking impact on surrounding streets.

4.7 Materials and Handling Area

All materials handling and plant equipment, including waste storage, are expected to be wholly stored on-site within the works site. It is not expected that any public road will be required for such purposes. However, if temporary use of any public road is required for temporary storage purposes or the like, prior consultation with Council will be undertaken. All relevant permit approvals will also be obtained prior to the commencement of such activities.

4.8 Road Occupancy License Requirements

Any construction activities that will impact on the operational efficiency of the State road network will require a road occupancy license (ROL) prior to the commencement of such construction activities. Multiplex will be responsible to obtain all relevant ROL's as required.

4.9 Work Zone Requirements

No works zone will be required as part of the works. All loading and unloading will occur wholly within the site.

5 Construction Traffic Assessment and Implications

5.1 Construction Traffic Generation

The estimated traffic movements associated with each stage of the construction works for each building are summarised in Table 5.1.

Table 5.1: Summary of Construction Traffic Movements

Construction Activities	Duration (months)	Daily Two-Way Movements	Hourly Two-Way Movements
Demolition	3 months	20 trips per day	Up to 2
Excavation and Site Preparation	3 months	10 trips per day	Up to 1
Construction and Building Works (Building A)	22 months	40 trips per day	Up to 4
Construction and Building Works (Building B)	14 months	40 trips per day	Up to 4
Public Domain Works (This is concurrent with the Building A construction and building works)	3 months	20 trips per day	Up to 2
Total	Building A - 28 months Building B - 14 months	-	-

The proposed construction traffic generation is considered to generate a modest level of vehicular traffic, with up to 8 truck movements (two-way) per hour expected during peak construction activities. As such, the proposed construction activities could not be expected to result in adverse impact on the surrounding road network.

5.2 Pedestrian and Cycle Access

Pedestrian and cycle access will be maintained around the work site as per existing conditions. Site personnel will manage pedestrians crossing the site access on Waterloo Road when necessary, when trucks access the site.

All relevant site hoarding and fencing will be installed around the works site to ensure pedestrian safety at all times. All relevant permit approvals will be obtained from Council (e.g. Class A and B Hoarding), prior to the commencement of any work.

5.3 Public Transport Facilities

The proposed construction activities are not expected to result in any changes to existing public transport services. All existing bus facilities and bus stops will be maintained at all times during the works.

5.4 Emergency Vehicles and Heavy Vehicles

No special provisions for emergency service vehicles or heavy vehicles are required as part of the proposed construction works. Emergency and heavy vehicle access shall be maintained at all times.

5.5 Adjoining Properties and Local Access

The proposed construction works will not impact existing local access to/from properties. Local access to properties will be maintained at all times during the works.

6 Construction Traffic Management Measures

6.1 Traffic Guidance Scheme

The proposed construction truck movements to/from the works site will be accompanied by advisory traffic control signage to minimise the traffic impact on the surrounding road network.

TTPP has prepared a site-specific Traffic Guidance Scheme (TGS) to manage construction vehicle access movements to/from the site. This TGS has been designed in accordance with TfNSW's Traffic Control at Works Sites manual and is enclosed in Appendix B.

Dedicated site personnel would be assigned on-site to manage and assist construction vehicle movements associated with the proposed construction works. At no time will site personnel be permitted to stop traffic on the public streets to facilitate trucks entering or exiting the site. Site personnel will only be able to assist, manage and guide construction trucks out of the site under suitable gaps in traffic. Site personnel will also manage pedestrians crossing the site access on Waterloo Road.

All advisory road signage will be installed in accordance with AS1742.3 Manual of uniform traffic control devices - Traffic control devices for works on roads and the TfNSW Traffic Control at Worksites Manual. Signs will be installed and maintained throughout the construction period, as required.

6.2 Vehicle Access

Construction vehicles will radio/call the site office on approach to ensure a loading area is available within the works site. All loading and unloading activities will be undertaken within the works site during the approved work hours. No queuing or marshalling of construction vehicles will be permitted on public roads. Notwithstanding this, if there are any materials spilt onto the road, site personnel and equipment will rectify the issue accordingly, subject to appropriate OH&S provision.

6.3 Truck Routes

The following protocols must be in place to minimise the impacts associated with the nominated construction vehicle routes:

- Site induction shall include procedures for accessing the site.
- Drivers shall adhere to the designated transport routes.

- Drivers shall be aware of pedestrians and cyclists in the vicinity of the site.
- Drivers shall be aware of existing sign posted speed limits.
- Site induction shall promote road safety and obey the NSW road rules at all times.
- Truck drivers must not drive under the influence of drugs and alcohol.

6.4 Heavy Vehicle Loads

All drivers will be required to adhere to the posted vehicle load limits on all roads and not overload vehicles beyond its maximum loading limits and/or relevant approvals.

All trucks entering or leaving the site with loads must have their loads covered and must not track dirt onto any public road. Prior to leaving site, covering truck loads is mandatory and when required, tailgates must be swept clean before leaving site.

6.5 Construction Worker Parking

As indicated previously, limited onsite car parking will be available during the works. However, a tool drop-off and storage facility is expected to be provided on-site. This will allow construction workers to drop off and store their tools, allowing them to use public transport to travel to and from the site.

Taking the above into consideration, it is proposed to implement the following measures to encourage workers to use public transport:

- Provide an on-site tool drop-off and storage facility to allow trade-people to store their specific tools for the project.
- Inform workers during the induction training of the existing public transport services around the site (i.e. train services at Macquarie Park train station).
- Encourage workers to use public transport to access the site, where possible.
- Assist and encourage workers to carpool to access the site during the induction training and toolbox talks (including carpooling from other public transport hubs).

6.6 Site Inspections and Record Keeping

The construction operation will be monitored to ensure that it proceeds as set out in the Contractor's Construction Management Plan provided by Multiplex. A daily inspection before the start of construction activity will take place to ensure that conditions accord with those stipulated in the plan and that there are no potential hazards. Any possible adverse impacts will be recorded and dealt with as they arise.

6.7 Worker Induction Training

All construction workers employed at the site by Multiplex shall be required to undergo a site induction training. The induction shall include nominated construction transport routes to and from the proposed work site for site personnel and construction vehicles, along with standard environmental, WH&S, driver protocols and emergency protocols. This training would be the responsibility of Multiplex.

6.8 Contingency Plans

The types of unplanned incidents that may occur during construction works include, but are not limited to:

- Motor vehicle crashes
- Environmental spills
- Construction type incidents
- Inclement weather conditions.

All issues would be reported to Multiplex who would inform and discuss with the appropriate personnel. The relevant authorities responsible for controlling hazards/ emergencies are shown in Table 6.1.

Table 6.1: Emergency Authorities

Potential Incident	Action Plan	Contact Details
Law Enforcement and Emergencies	Police	Ryde Police Station Address: 810 Victoria Road, Ryde NSW 2112 Phone: (02) 9808 7401
Fire	Fire and Rescue NSW	Ryde Fire Station Address: 120F Coxs Rd, North Ryde NSW 2113 Phone: 02 9493 1042
Hazardous Material	Fire and Rescue NSW	

Table 6.3 outlines an action plan, in respect to traffic management, which would be applied for different types of incidents.

Table 6.2: Contingency Plans

Potential Incident	Action Plan
Equipment Breakdown	Modify traffic control arrangement to accommodate equipment breakdown
Work Vehicle Breakdown	Construction Manager to call tow truck company. Cease work if necessary.
Poor Weather Conditions	Assess all possible risk / hazards. If necessary, postpone and reprogram works. Continuously monitor working and traffic conditions, and if necessary, cease work.
Unplanned Incidents	Where possible, cease work. Modify traffic control and manage site until emergency services arrive. Support emergency services.

6.9 Liaison with Stakeholders

Multiplex shall appoint a representative to manage all community queries and/or issues relating to the project for actioning, as necessary. Written notification will be provided to likely and potentially affected sensitive receivers prior to commencement of any activities associated with construction. This will include local residents, local businesses and relevant authorities and be provided at least 7 days prior to construction commencing. The format of notification may include such measures such as email notification or letter box drops.

7 Conclusion

The CTMP has been prepared to document the proposed construction activities and associated traffic management measures necessary to facilitate the construction works at 269 Lane Cove Road, Macquarie Park.

The key findings contained in this CTMP are as per below:

- The construction of the proposed development is expected to generate up to 8 vehicles per hour (two-way) during the peak construction activities.
- Given the expected low volume of construction vehicles, construction vehicle movements to and from the site can be satisfactorily accommodated in the surrounding road network.
- No pedestrian or cyclist facilities will be impacted as a result of the construction activities.
- It is proposed that loading/unloading of trucks to occur within the site, with construction vehicle access provided off Waterloo Road via the internal road.
- A number of driver protocols will be established as part of the site induction procedure for drivers to ensure the safety of motorists, pedestrians and cyclists.
- Truck drivers are to be instructed to use the designated truck routes to/from the site.

In summary, it is concluded that the proposed traffic control measures will adequately address potential implications associated with proposed construction activities. This CTMP fulfils the requirements of the SEARs relating to SSD-63168959.

Appendix A

Swept Path Assessment

VEHICLE ENTERING

VEHICLE EXITING

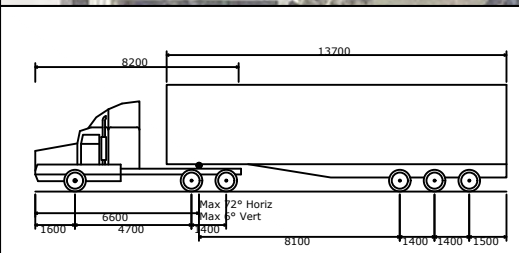

AV - Articulated Vehicle	19000mm
Overall Length	2500mm
Overall Width	4301mm
Min Body Ground Clearance	418mm
Track Width	2500mm
Lock-to-lock time	6.00s
Curb to Curb Turning Radius	12500mm

KEY:

	Forward	Reverse
Wheel path		
Body envelope		
300mm clearance		

REV.	DESCRIPTION	DRAWN	CHECK	APP'D	DATE
A	ISSUE FOR DISCUSSION	JG	JN	KH	16/02/24



PROJECT: 269 LANE COVE ROAD, MACQUARIE PARK

TITLE: SWEPT PATH ANALYSIS
AS2890.2 19m ARTICULATED VEHICLE

DWG No.	23217CAD005	
	FIGURE 1	
DATE STAMP	16 FEBRUARY 2024	
PROJECT No.	SCALE	REV.
23217	1:500 @A3	A

File name: 23217CAD005-2402-16-SWEPT PATH.dwg Date: 16 February 2024

VEHICLE ENTERING

VEHICLE EXITING

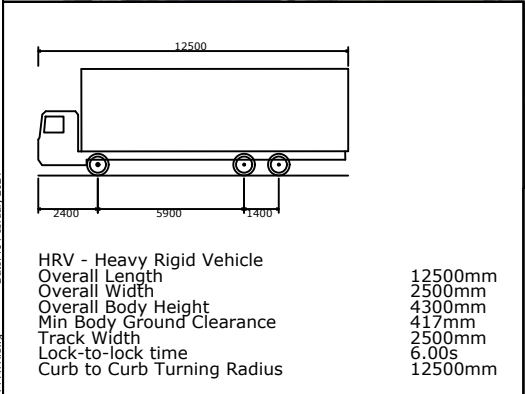

KEY:

	Forward	Reverse
Wheel path		
Body envelope		
300mm clearance		

REV.	DESCRIPTION	DRAWN	CHECK	APP'D	DATE
A	ISSUE FOR DISCUSSION	JG	JN	KH	16/02/24



PROJECT
269 LANE COVE ROAD, MACQUARIE PARK

TITLE
**SWEPT PATH ANALYSIS
 AS2890.2 12.5m HEAVY RIGID VEHICLE**

DWG No.	23217CAD005	
	FIGURE 2	
DATE STAMP	16 FEBRUARY 2024	
PROJECT No.	SCALE	REV.
23217	1:500 @A3	A

File name: 23217CAD005-2402-16-SWEPT PATH.dwg Date: 16 February 2024

Appendix B

Traffic Guidance Scheme (TGS)

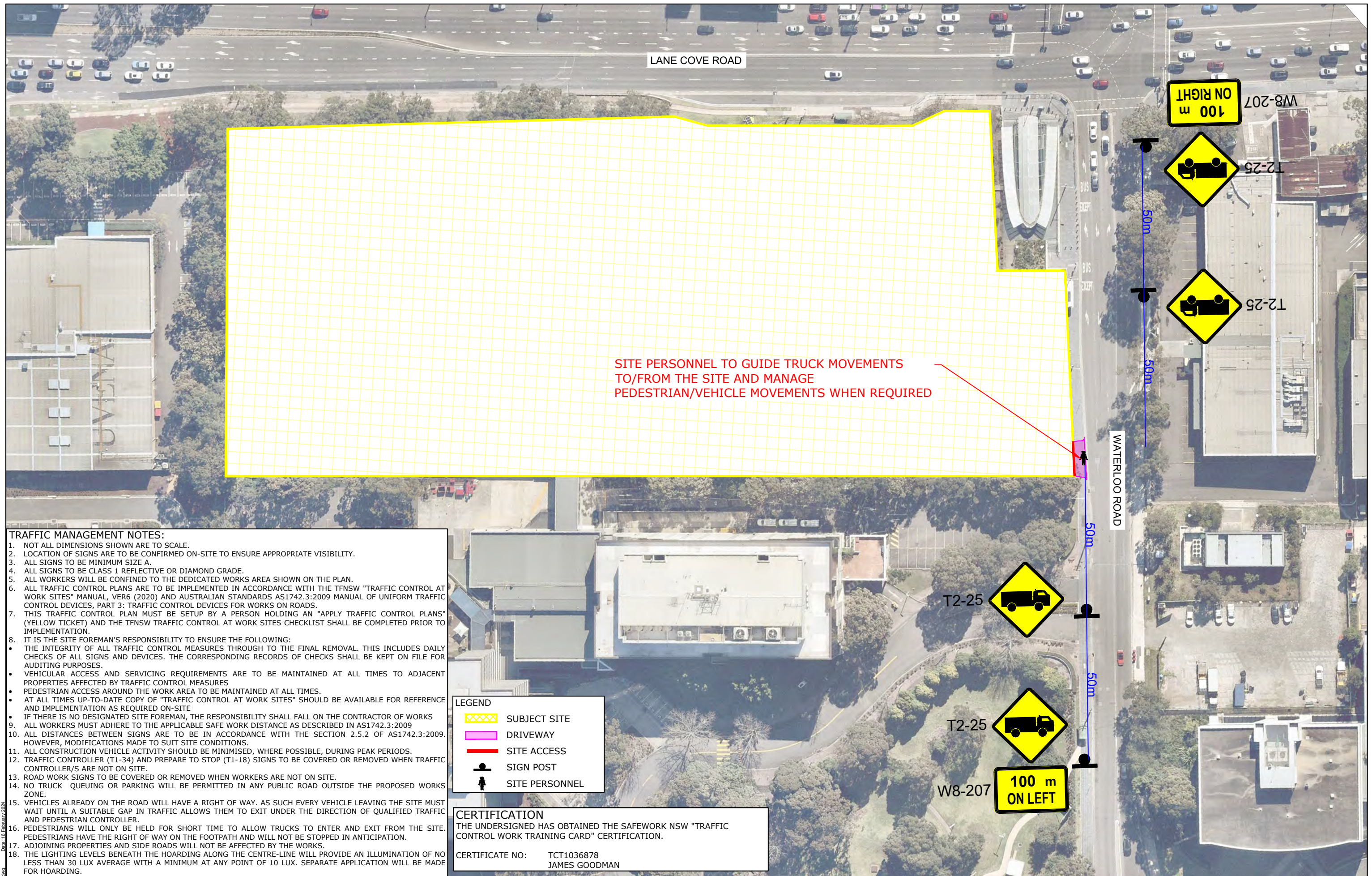

SITE PERSONNEL TO GUIDE TRUCK MOVEMENTS TO/FROM THE SITE AND MANAGE PEDESTRIAN/VEHICLE MOVEMENTS WHEN REQUIRED

TRAFFIC MANAGEMENT NOTES:

- NOT ALL DIMENSIONS SHOWN ARE TO SCALE.
- LOCATION OF SIGNS ARE TO BE CONFIRMED ON-SITE TO ENSURE APPROPRIATE VISIBILITY.
- ALL SIGNS TO BE MINIMUM SIZE A.
- ALL SIGNS TO BE CLASS 1 REFLECTIVE OR DIAMOND GRADE.
- ALL WORKERS WILL BE CONFINED TO THE DEDICATED WORKS AREA SHOWN ON THE PLAN.
- ALL TRAFFIC CONTROL PLANS ARE TO BE IMPLEMENTED IN ACCORDANCE WITH THE TFNSW "TRAFFIC CONTROL AT WORK SITES" MANUAL, VER6 (2020) AND AUSTRALIAN STANDARDS AS1742.3:2009 MANUAL OF UNIFORM TRAFFIC CONTROL DEVICES, PART 3: TRAFFIC CONTROL DEVICES FOR WORKS ON ROADS.
- THIS TRAFFIC CONTROL PLAN MUST BE SETUP BY A PERSON HOLDING AN "APPLY TRAFFIC CONTROL PLANS" (YELLOW TICKET) AND THE TFNSW TRAFFIC CONTROL AT WORK SITES CHECKLIST SHALL BE COMPLETED PRIOR TO IMPLEMENTATION.
- IT IS THE SITE FOREMAN'S RESPONSIBILITY TO ENSURE THE FOLLOWING:
 - THE INTEGRITY OF ALL TRAFFIC CONTROL MEASURES THROUGH TO THE FINAL REMOVAL. THIS INCLUDES DAILY CHECKS OF ALL SIGNS AND DEVICES. THE CORRESPONDING RECORDS OF CHECKS SHALL BE KEPT ON FILE FOR AUDITING PURPOSES.
 - VEHICULAR ACCESS AND SERVICING REQUIREMENTS ARE TO BE MAINTAINED AT ALL TIMES TO ADJACENT PROPERTIES AFFECTED BY TRAFFIC CONTROL MEASURES
 - PEDESTRIAN ACCESS AROUND THE WORK AREA TO BE MAINTAINED AT ALL TIMES.
 - AT ALL TIMES UP-TO-DATE COPY OF "TRAFFIC CONTROL AT WORK SITES" SHOULD BE AVAILABLE FOR REFERENCE AND IMPLEMENTATION AS REQUIRED ON-SITE
 - IF THERE IS NO DESIGNATED SITE FOREMAN, THE RESPONSIBILITY SHALL FALL ON THE CONTRACTOR OF WORKS
- ALL WORKERS MUST ADHERE TO THE APPLICABLE SAFE WORK DISTANCE AS DESCRIBED IN AS1742.3:2009
- ALL DISTANCES BETWEEN SIGNS ARE TO BE IN ACCORDANCE WITH THE SECTION 2.5.2 OF AS1742.3:2009. HOWEVER, MODIFICATIONS MADE TO SUIT SITE CONDITIONS.
- ALL CONSTRUCTION VEHICLE ACTIVITY SHOULD BE MINIMISED, WHERE POSSIBLE, DURING PEAK PERIODS.
- TRAFFIC CONTROLLER (T1-34) AND PREPARE TO STOP (T1-18) SIGNS TO BE COVERED OR REMOVED WHEN TRAFFIC CONTROLLER/S ARE NOT ON SITE.
- ROAD WORK SIGNS TO BE COVERED OR REMOVED WHEN WORKERS ARE NOT ON SITE.
- NO TRUCK QUEUING OR PARKING WILL BE PERMITTED IN ANY PUBLIC ROAD OUTSIDE THE PROPOSED WORKS ZONE.
- VEHICLES ALREADY ON THE ROAD WILL HAVE A RIGHT OF WAY. AS SUCH EVERY VEHICLE LEAVING THE SITE MUST WAIT UNTIL A SUITABLE GAP IN TRAFFIC ALLOWS THEM TO EXIT UNDER THE DIRECTION OF QUALIFIED TRAFFIC AND PEDESTRIAN CONTROLLER.
- PEDESTRIANS WILL ONLY BE HELD FOR SHORT TIME TO ALLOW TRUCKS TO ENTER AND EXIT FROM THE SITE. PEDESTRIANS HAVE THE RIGHT OF WAY ON THE FOOTPATH AND WILL NOT BE STOPPED IN ANTICIPATION.
- ADJOINING PROPERTIES AND SIDE ROADS WILL NOT BE AFFECTED BY THE WORKS.
- THE LIGHTING LEVELS BENEATH THE HOARDING ALONG THE CENTRE-LINE WILL PROVIDE AN ILLUMINATION OF NO LESS THAN 30 LUX AVERAGE WITH A MINIMUM AT ANY POINT OF 10 LUX. SEPARATE APPLICATION WILL BE MADE FOR HOARDING.

LEGEND

	SUBJECT SITE
	DRIVEWAY
	SITE ACCESS
	SIGN POST
	SITE PERSONNEL

CERTIFICATION
 THE UNDERSIGNED HAS OBTAINED THE SAFEWORK NSW "TRAFFIC CONTROL WORK TRAINING CARD" CERTIFICATION.
 CERTIFICATE NO: TCT1036878
 JAMES GOODMAN

REV.	DESCRIPTION	DRAWN	CHECK	APP'D	DATE
A	ISSUE FOR DISCUSSION	JG	JN	KH	16/02/24



PROJECT
269 LANE COVE ROAD, MACQUARIE PARK

TITLE
TRAFFIC GUIDANCE SCHEME

DWG No.	23217CAD006		
	FIGURE 1		
DATE STAMP	16 FEBRUARY 2024		
PROJECT No.	SCALE	REV.	
23217	NTS	A	

Date: 16 February 2024
 Filename: 23217CAD006-2402-16-TGS.dwg

The Transport Planning Partnership
Suite 402 Level 4, 22 Atchison Street
St Leonards NSW 2065

P.O. Box 237
St Leonards NSW 1590

02 8437 7800

info@tpp.net.au

www.tpp.net.au