

REFER DRAWING EX_AR_D_20000 FOR CONTINUATION

REFER LANDSCAPE ARCHITECTURE DRAWINGS FOR CONTINUATION

REFER LANDSCAPE ARCHITECTURE DRAWINGS FOR CONTINUATION

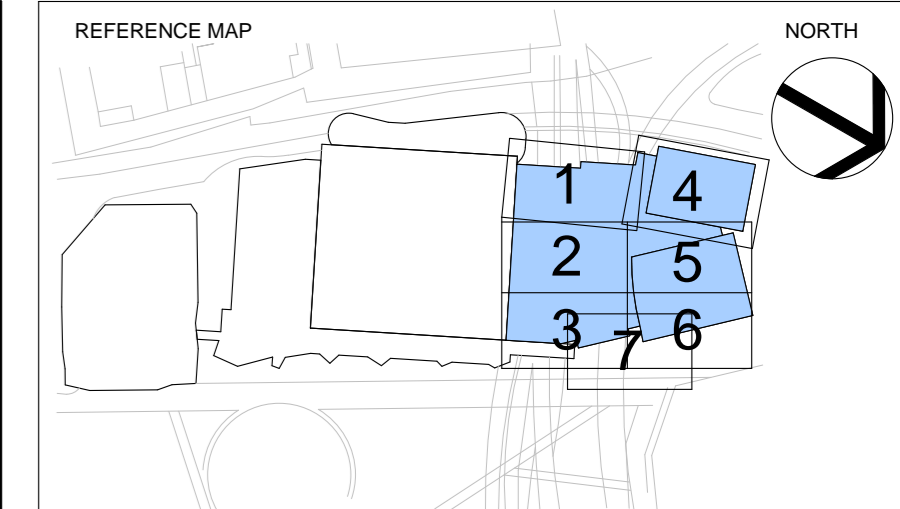

- NOTES
1. DO NOT SCALE DRAWINGS. WRITTEN DIMENSIONS GOVERN.
 2. ALL DIMENSIONS ARE IN METRES UNLESS NOTED OTHERWISE.
 3. ALL DIMENSIONS SHALL BE VERIFIED ON SITE BEFORE PROCEEDING WITH THE WORK. HASSELL+POPULOUS SHALL BE NOTIFIED IN WRITING OF ANY DISCREPANCIES.
 4. THIS DRAWING MUST BE READ IN CONJUNCTION WITH ALL RELEVANT CONTRACTS, SPECIFICATIONS AND DRAWINGS.

© COPYRIGHT OF THIS DRAWING IS VESTED IN HASSELL+POPULOUS. 2014 HASSELL+POPULOUS PTY LTD.
THIS DRAWING IS AN UNCONTROLLED COPY UNLESS NOTED OTHERWISE.

REV	DESCRIPTION	DATE
1	ISSUED FOR INFORMATION	08.05.13
2	ISSUED FOR INFORMATION	17.05.13
3	ISSUED FOR INFORMATION	23.05.13
4	ISSUED FOR INFORMATION	06.06.13
A	ISSUED FOR DEVELOPMENT APPLICATION	24.06.13
5	DS1 PLANNING FREEZE	01.07.13
6	ISSUED FOR DS1	11.07.13
7	ISSUED FOR DS1	24.07.13
8	CURTAIN WALL AFT ISSUE	25.07.13
9	ISSUED FOR INFORMATION	13.08.13
10	ISSUED FOR INFORMATION	30.08.13
11	ISSUED FOR INFORMATION	06.09.13
12	ISSUED FOR INFORMATION	24.09.13
13	ISSUED FOR INFORMATION	01.10.13
14	ISSUED FOR INFORMATION	04.10.13
15	ISSUED FOR INFORMATION	22.10.13
16	ISSUED FOR REVIEW	05.11.13
17	ISSUED FOR INFORMATION	06.11.13
18	ISSUED FOR SERVICES INFORMATION	11.11.13
19	ISSUED FOR INFORMATION	12.11.13
B	ISSUED FOR SECTION 96 APPLICATION	04.12.13
20	ISSUED FOR INFORMATION	04.12.13
21	ISSUED FOR INFORMATION	04.02.14
22	FACADE AND ROOFING - AFT REVIEW	16.12.13
23	ISSUED FOR AFT	16.01.14
24	ISSUED FOR AFT	31.01.14
25	ISSUED FOR INFORMATION	04.02.14
26	DS2 ARCHITECTURAL ISSUE	16.02.14
C	DS2 - CONCRETE OUTLINE	21.02.14
D	AFG - BUILDING ENVELOPE	12.03.14
27	DS2 - ARCHITECTURAL	21.03.14
E	DS2 - ARCHITECTURAL	25.03.14
F	ISSUED FOR SECTION 96 APPLICATION	28.03.14
G	ISSUED FOR INFORMATION	01.04.14
H	ISSUED FOR SECTION 96 APPLICATION	02.04.14

ARCHITECT - PRINCIPAL DESIGN CONSULTANT
HASSELL+POPULOUS
HASSELL + POPULOUS PTY LTD ABN 5461979317
LEVEL 2, PIER 8/9
23 HICKSON ROAD
SYDNEY NSW 2000 AUSTRALIA
T +61 2 9101 2000 F +61 2 9101 2100

- CONSULTANTS
- Robert Bird Group** - STRUCTURAL SERVICES
LEVEL 5, 9 CASTLEREAGH ST, SYDNEY NSW 2000 (02) 9346 3000
 - AECOM** - BUILDING / ENVIRONMENTAL SERVICES
LEVEL 2, 9/24 HICKSON RD, MILLERS POINT NSW 2000 (02) 9334 0000
 - ARMIS** - HYDRAULIC SERVICES
LEVEL 2, 9/24 HICKSON RD, MILLERS POINT NSW 2000 (02) 8038 8370
 - Hyder** - CIVIL / TRAFFIC SERVICES
51 HAWKER ST, NORTH SYDNEY NSW 2000 (02) 8907 9000

CLIENT
Lend Lease
LEND LEASE BUILDING PTY LTD
LEVEL 4, THE BOND, 30 HICKSON RD
MILLERS POINT, NSW 2000
(02) 9236 6111

PROJECT
DARLING HARBOUR LIVE
ICC

DRAWING TITLE
LOBBY
GA PLAN
LEVEL 0
RL 3.5

STATUS
SECTION 96

SCALE @ A1 (50% @ A2) DRAWN: LM CO-ORD: DH REVIEWED: [Signature] APPROVED: [Signature]
PROJECT NUMBER: 003688 DRAWING NUMBER: CO_AR_D_200000 REV: H

Original Sheet Size: A0 - 1189 x 841mm
02/07/14 12:16:27 PM

FOR APPROVAL

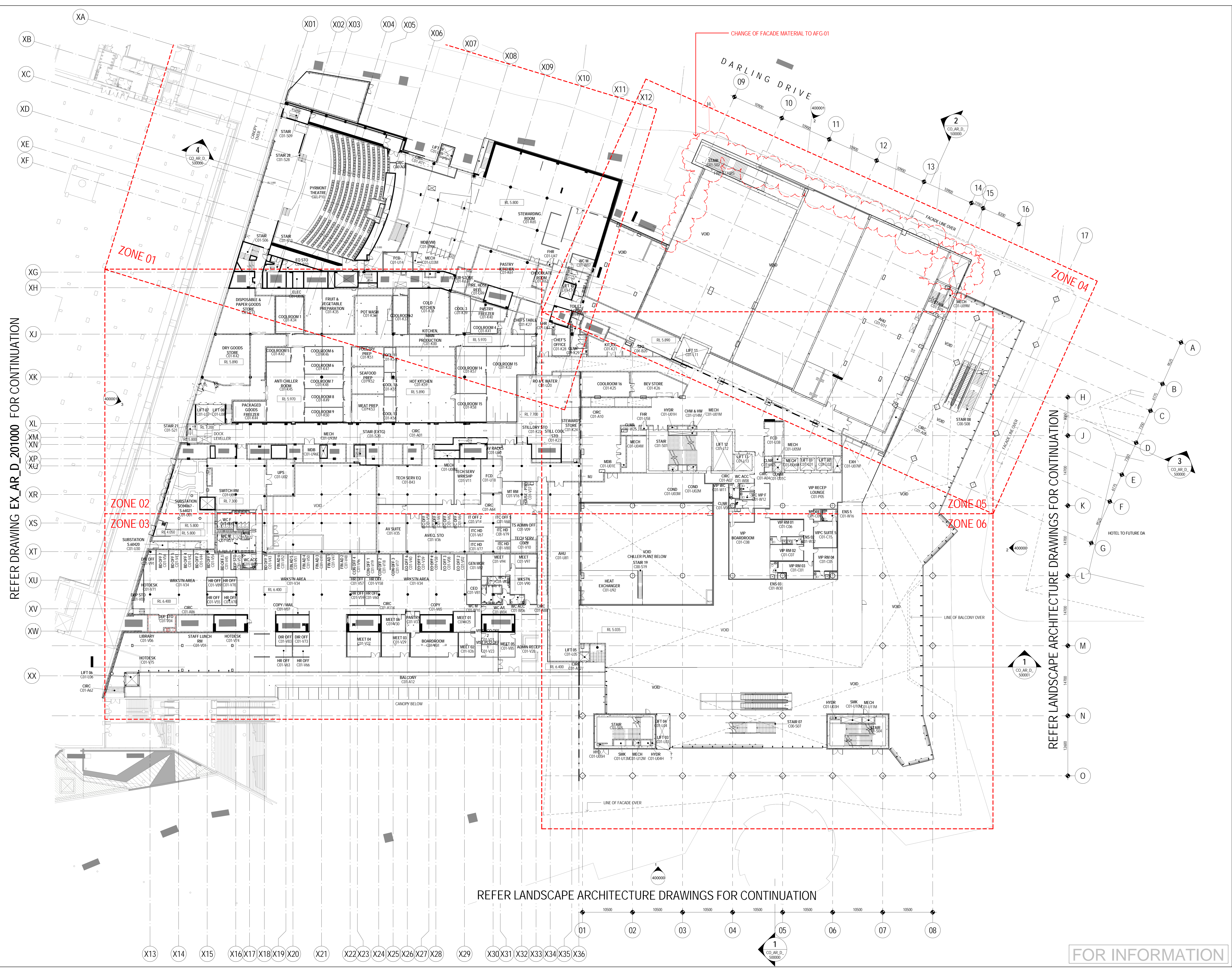

REFER DRAWING EX_AR_D_201000 FOR CONTINUATION

REFER LANDSCAPE ARCHITECTURE DRAWINGS FOR CONTINUATION

REFER LANDSCAPE ARCHITECTURE DRAWINGS FOR CONTINUATION

REFERENCE MAP

NORTH

1 4
2 5
3 6

NOTES

- DO NOT SCALE DRAWINGS. WRITTEN DIMENSIONS GOVERN.
- ALL DIMENSIONS ARE IN METRES UNLESS NOTED OTHERWISE.
- ALL DIMENSIONS SHALL BE VERIFIED ON SITE BEFORE PROCEEDING WITH THE WORK. HASSELL+POPULOUS SHALL BE NOTIFIED IN WRITING OF ANY DISCREPANCIES.
- THIS DRAWING MUST BE READ IN CONJUNCTION WITH ALL RELEVANT CONTRACTS, SPECIFICATIONS AND DRAWINGS.

© COPYRIGHT OF THIS DRAWING IS HELD BY HASSELL+POPULOUS. 2014 HASSELL+POPULOUS PTY LTD

THIS DRAWING IS AN UNCONTROLLED COPY UNLESS NOTED OTHERWISE

REV	DESCRIPTION	DATE
1	ISSUED FOR INFORMATION	09.05.13
2	ISSUED FOR INFORMATION	17.05.13
3	ISSUED FOR INFORMATION	23.05.13
4	ISSUED FOR INFORMATION	06.06.13
A	ISSUED FOR DEVELOPMENT APPLICATION	24.06.13
5	DS1 PLANNING FREEZE	01.07.13
6	ISSUED FOR DS1	11.07.13
7	ISSUED FOR DS1	24.07.13
8	CURTAIN WALL AFT ISSUE	25.07.13
9	ISSUED FOR INFORMATION	13.08.13
10	ISSUED FOR INFORMATION	30.08.13
11	ISSUED FOR INFORMATION	06.09.13
12	ISSUED FOR INFORMATION	24.09.13
13	ISSUED FOR INFORMATION	01.10.13
14	ISSUED FOR INFORMATION	04.10.13
15	ISSUED FOR INFORMATION	22.10.13
16	ISSUED FOR REVIEW	05.11.13
17	ISSUED FOR INFORMATION	06.11.13
18	ISSUED FOR SERVICES INFORMATION	11.11.13
19	ISSUED FOR INFORMATION	12.11.13
B	ISSUED FOR SECTION 96 APPLICATION	04.12.13
20	ISSUED FOR INFORMATION	04.12.13
21	ISSUED FOR INFORMATION	10.12.13
22	FACADE AND ROOFING - AFT REVIEW	16.12.13
23	ISSUED FOR AFT	16.01.14
24	ISSUED FOR AFT	31.01.14
25	ISSUED FOR INFORMATION	04.02.14
26	DS2 - ARCHITECTURAL ISSUE	16.02.14
C	DS2 - CONCRETE OUTLINE	21.02.14
D	AFC - BUILDING ENVELOPE	12.03.14
27	DS2 - ARCHITECTURAL	21.03.14
E	DS2 - ARCHITECTURAL	25.03.14
F	ISSUED FOR SECTION 96 APPLICATION	28.03.14
G	ISSUED FOR INFORMATION	01.04.14
H	ISSUED FOR SECTION 96 APPLICATION	02.04.14

ARCHITECT: PRINCIPAL DESIGN CONSULTANT
HASSELL+POPULOUS
HASSELL + POPULOUS PTY LTD ABN 3461979317
LEVEL 2, PIER 8/9
23 HICKSON ROAD
SYDNEY NSW 2000 AUSTRALIA
T +61 2 9101 2000 F +61 2 9101 2100

CONSULTANTS

- Robert Bird Group** STRUCTURAL SERVICES
LEVEL 5, 9 CASTLEREAGH ST, SYDNEY
NSW 2000
(02) 9246 3000
- AECOM** BUILDING / ENVIRONMENTAL SERVICES
LEVEL 21, 40 GEORGE ST, SYDNEY
NSW 2000
(02) 9334 0000
- C.J. ARMIB** HYDRAULIC SERVICES
LEVEL 2, 9/24 HICKSON RD, MILLERS POINT
NSW 2000
(02) 8036 8370
- Hyder** CIVIL / TRAFFIC SERVICES
51 BALMAINER ST, NORTH SYDNEY
NSW 2000
(02) 8907 9000

CLIENT
Lend Lease
LEND LEASE BUILDING PTY LTD
LEVEL 4, THE BOND, 30 HICKSON RD
MILLERS POINT, NSW 2000
(02) 9236 6111

PROJECT
**DARLING HARBOUR LIVE
ICC**

DRAWING TITLE
**VENUE MANAGEMENT
GA PLAN
LEVEL 1
RL 7.2**

STATUS
SECTION 96

SCALE @ A1: 1/200 @ A2
1: 250
PROJECT NUMBER: 003688
DRAWING NUMBER: CO_AR_D_201000
REV: H

FOR INFORMATION

Original Sheet Size: A0 - 1189 x 841mm

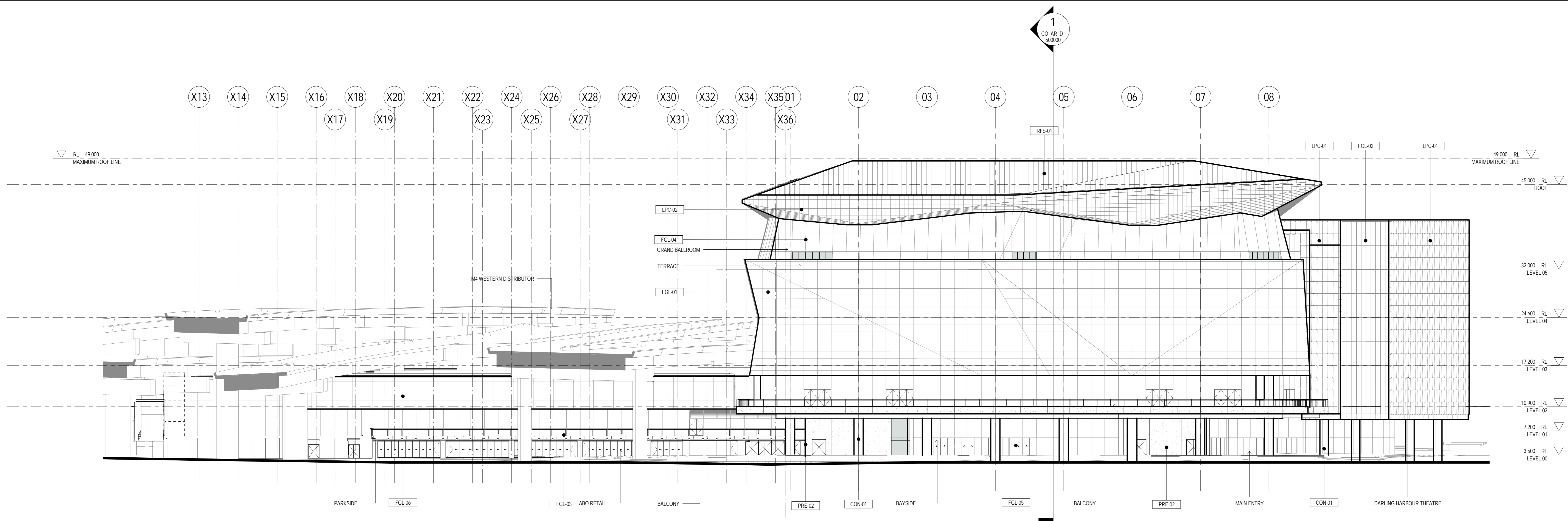

1 EASTERN ELEVATION
1:250

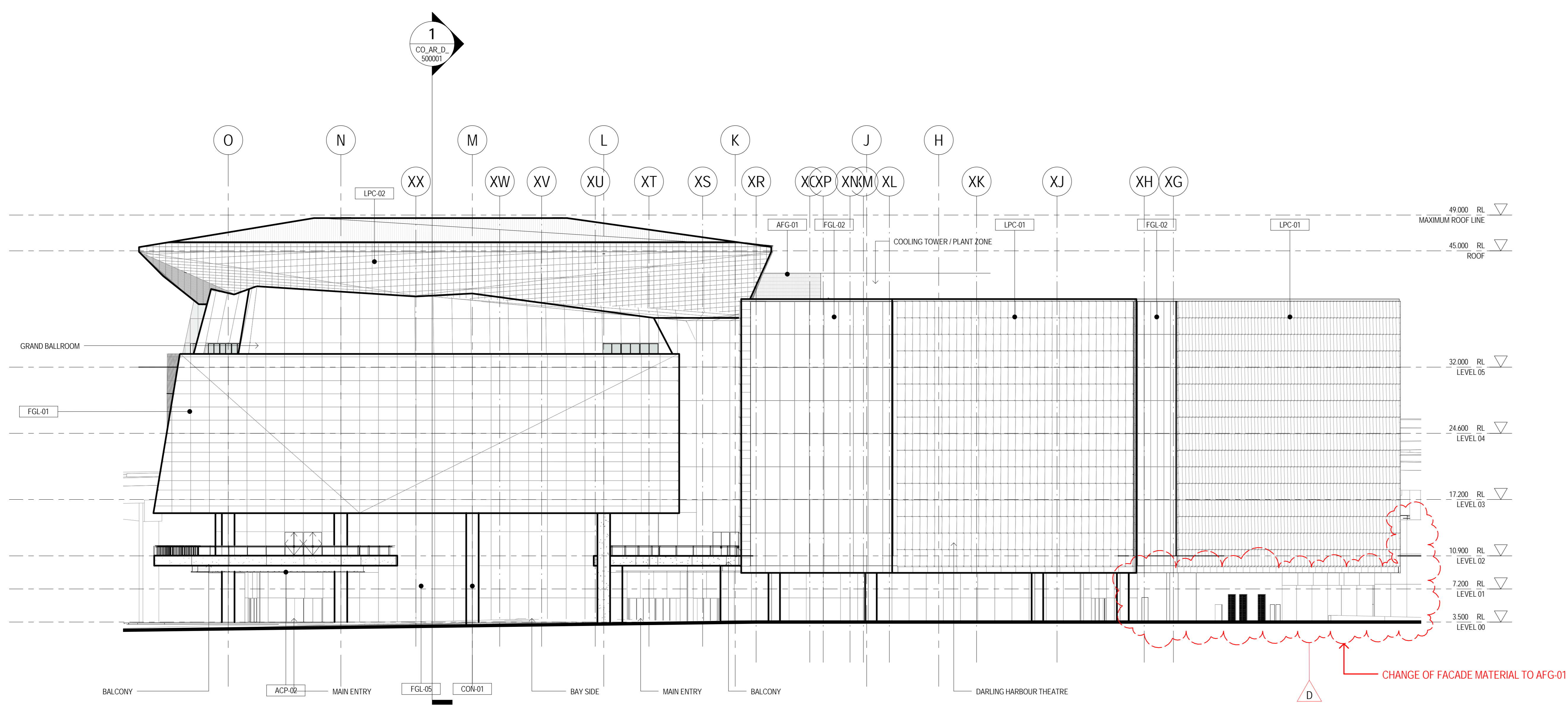

2 NORTHERN ELEVATION
1:250

PRECAST PRE-01 Precast Panel PRE-04 Precast Flat Panel PRE-05 Precast Stair Panel PRE-06 Precast Confirming PRE-07 Precast Sash Edge PRE-11 Precast Enclosure	CONCRETE CON-01 Off Form Concrete - Class 2 BLOCKWORK BLK-01 Concrete Blockwork - 140mm	FACADE SYSTEMS ACP-01 Composite Aluminum Panel (Cassette) MIP-01 Metal Facade Insulated Panel - Standard Vertical Panel MIP-03 Metal Facade Insulated Panel - Loading Deck Screen (Acoustic) MIP-04 Porcelain Stoneware Panel Cladding - Rainscreen PMC-01 Profile Metal Cladding WVP-01 Composite Wood Veneered Panel	FACADE GLAZING FGL-01 Glazing Assembly 1 FGL-02 Glazing Assembly 2 FGL-03 Glazing Assembly 3 FGL-04 Glazing Assembly 4 - Ballroom FGL-05 Glazing Assembly 5 FGL-06 Glazing Assembly 6 - Existing East Facade ICC FGL-07 Glazing Assembly 7 FGL-08 Glazing Assembly 8 FGL-09 Glazing Assembly 9 FGL-10 Glazing Assembly 10 - ABO FGL-11 Glazing Assembly 11 - Entry FGL-14 Glazing Assembly 14	FACADE LOUVRES FLV-02 Class A Weatherproof Louvers - Concealed Frame	FACADE / ROOF SCREENS AFG-01 Aluminum Flat Bar Grille AFG-02 Aluminum Flat Bar Grille - Horizontal EXM-01 Expanded Mesh Screen EXM-02 Expanded Mesh Screen	FACADE / SOFFITS ACP-02 Composite Aluminum Panel - Soffits CFC-01 Compressed Fibre Cement Sheet - Soffit LPC-02 Porcelain Panel Cladding - Soffit	FACADE TRIMS & CAPPINGS FCT-01 Colorbond Façade Flashing FCT-04 Colorbond Façade Flashing	ROOFING RFS-01 Metal Roof Sheeting RFS-02 Metal Roof Sheeting RFS-04 Re-Roofing (Parkside)
--	--	---	--	--	---	---	--	--

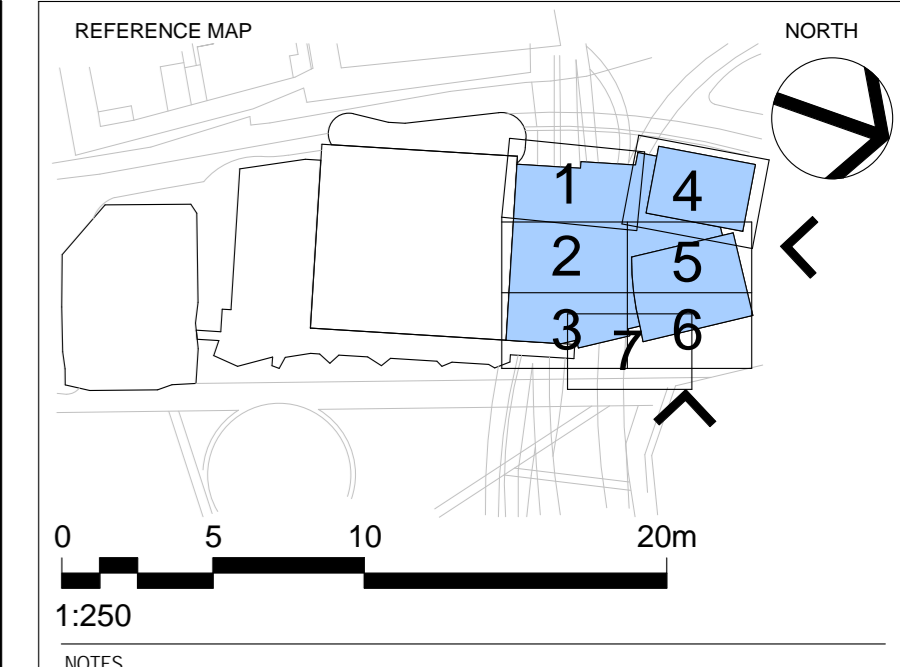

NOTES
 1. DO NOT SCALE DRAWINGS. WRITTEN DIMENSIONS GOVERN.
 2. ALL DIMENSIONS ARE IN MILLIMETRES UNLESS NOTED OTHERWISE.
 3. ALL DIMENSIONS SHALL BE VERIFIED ON-SITE BEFORE PROCEEDING WITH THE WORK. HASSELL+POPULOUS SHALL BE NOTIFIED IN WRITING OF ANY DISCREPANCIES.
 4. THIS DRAWING MUST BE READ IN CONJUNCTION WITH ALL RELEVANT CONTRACTS, SPECIFICATIONS AND DRAWINGS.

© COPYRIGHT OF THIS DRAWING IS VESTED IN HASSELL+POPULOUS. 2014 HASSELL+POPULOUS PTY LTD
 THIS DRAWING IS AN UNCONTROLLED COPY UNLESS NOTED OTHERWISE.

REV	DESCRIPTION	DATE
A	ISSUED FOR DEVELOPMENT APPLICATION	24.06.13
B	ISSUED FOR SECTION 96 APPLICATION	04.12.13
C	ISSUED FOR SECTION 96 APPLICATION	28.03.14
D	ISSUED FOR SECTION 96 APPLICATION	02.04.14

ARCHITECT - PRINCIPAL DESIGN CONSULTANT
HASSELL+POPULOUS
 HASSELL + POPULOUS PTY LTD ABN 346197317
 LEVEL 2, PIER 8/9
 23 HICKSON ROAD
 SYDNEY NSW 2000 AUSTRALIA
 T +61 2 9101 2000 F +61 2 9101 2100

CONSULTANTS

STRUCTURAL SERVICES
 LEVEL 5, 9 CASTLEREAGH ST, SYDNEY NSW 2000
 02 8246 3000
 Robert Bird Group

BUILDING / ENVIRONMENTAL SERVICES
 LEVEL 21, 420 GEORGE ST, SYDNEY NSW 2000
 02 9334 0000
 AECOM

HYDRAULIC SERVICES
 LEVEL 2, 9/24 HICKSON RD, MILLERS POINT NSW 2000
 02 8036 8370
 J. ARMISTEAD

CIVIL / TRAFFIC SERVICES
 31/41 WALKER ST, NORTH SYDNEY NSW 2060
 02 8907 9000
 Hyder

CLIENT
Lend Lease Building Pty Ltd
 LEVEL 4, THE BOND, 30 HICKSON RD MILLERS POINT, NSW 2000
 (02) 9236 6111
 Lend Lease

PROJECT
DARLING HARBOUR LIVE ICC

DRAWING TITLE
SECTION 96 OVERALL ELEVATIONS

STATUS
SECTION 96

SCALE @ A3 / 50% @ A2
 As indicated MD MD
 PROJECT NUMBER 003688 DRAWING NUMBER CO_AR_D_400000 REV D

APPROVED
 [Signature]
 02/04/14 12:24:43 PM
 Original Sheet Size: A0 - 1189 x 841mm

FOR APPROVAL

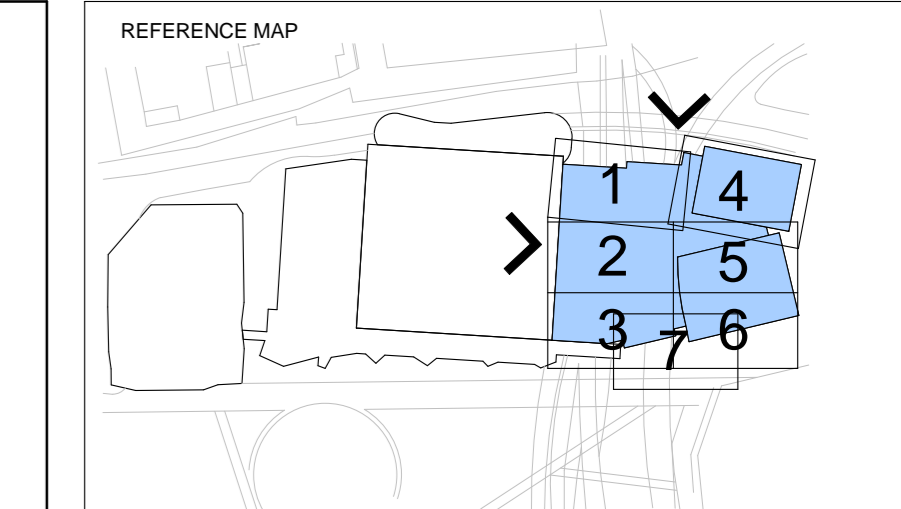

0 5 10 20m
1:250

NOTES
 1. DO NOT SCALE DRAWINGS. WRITTEN DIMENSIONS GOVERN.
 2. ALL DIMENSIONS ARE IN MILLIMETRES UNLESS NOTED OTHERWISE.
 3. ALL DIMENSIONS SHALL BE VERIFIED ON SITE BEFORE PROCEEDING WITH THE WORK. HASSELL+POPULOUS SHALL BE NOTIFIED IN WRITING OF ANY DISCREPANCIES.
 4. THIS DRAWING MUST BE READ IN CONJUNCTION WITH ALL RELEVANT CONTRACTS, SPECIFICATIONS AND DRAWINGS.

© COPYRIGHT OF THIS DRAWING IS VESTED IN HASSELL+POPULOUS. 2014 HASSELL+POPULOUS PTY LTD

THIS DRAWING IS AN UNCONTROLLED COPY UNLESS NOTED OTHERWISE

REV	DESCRIPTION	DATE
A	ISSUED FOR DEVELOPMENT APPLICATION	24.06.13
B	ISSUED FOR SECTION 96 APPLICATION	04.12.13
C	ISSUED FOR SECTION 96 APPLICATION	28.03.14
D	ISSUED FOR SECTION 96 APPLICATION	02.04.14

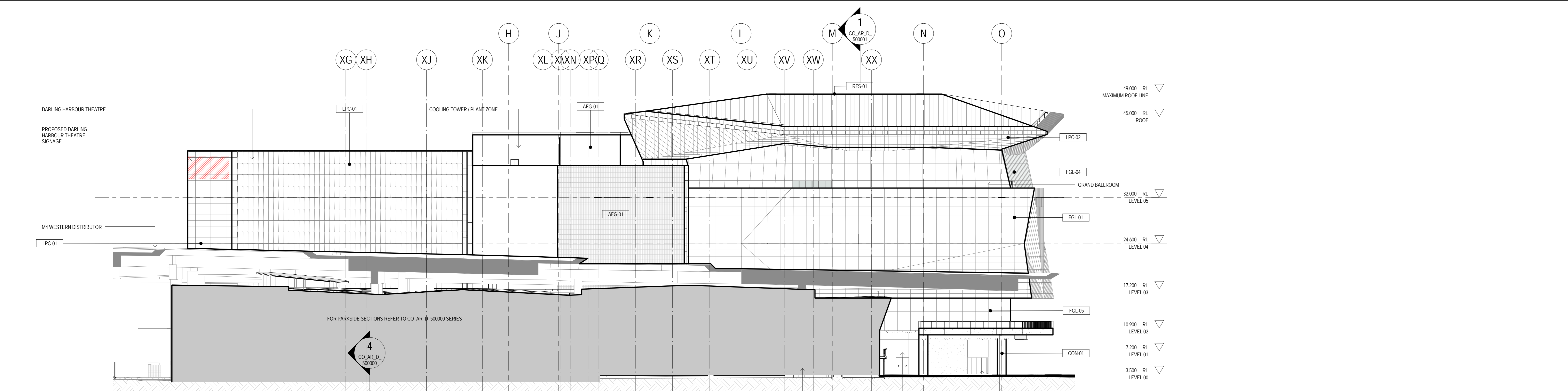

1 SOUTHERN ELEVATION
1:250

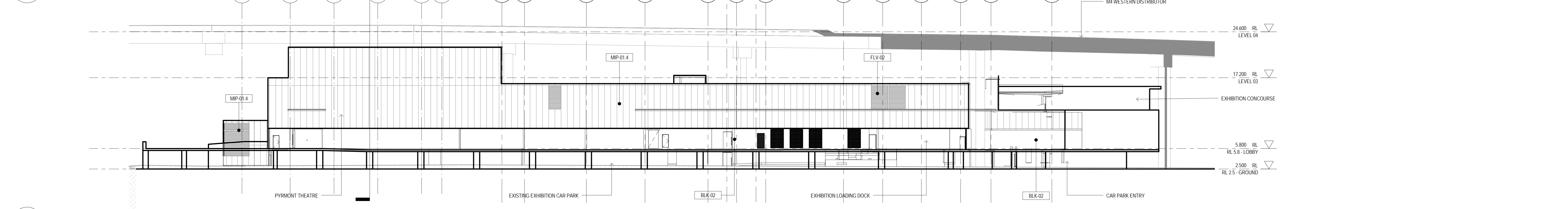

2 SOUTHERN ELEVATION - PARKSIDE
1:250

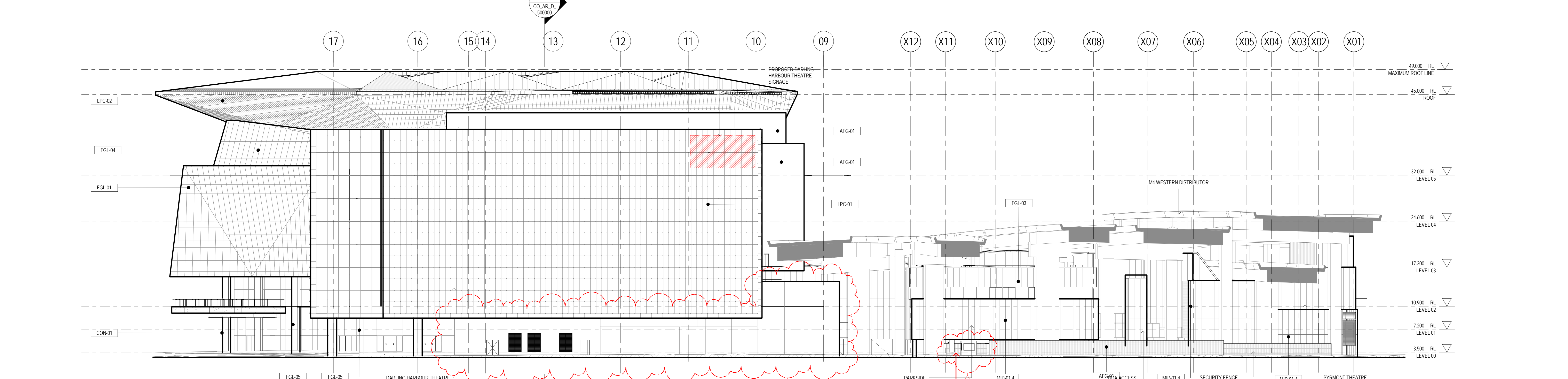

3 WESTERN ELEVATION
1:250

PRECAST	CONCRETE	FAÇADE SYSTEMS	FAÇADE GLAZING	FAÇADE LOUVRES	FAÇADE / ROOF SCREENS	FAÇADE / SOFFITS	FAÇADE TRIMS & CAPPINGS	ROOFING
<ul style="list-style-type: none"> PRE-01 Precast Panel PRE-04 Precast Flat Panel PRE-05 Precast Star Panel - To be Confirmed PRE-07 Precast - Slab Edge PRE-11 Precast - Enclosure 	<ul style="list-style-type: none"> CON-01 Off Form Concrete - Class 2 BLK-01 Concrete Blockwork - 140mm 	<ul style="list-style-type: none"> ACP-01 Composite Aluminum Panel (Cassette) MIP-01 Metal Facade Insulated Panel - Standard MIP-03 Metal Facade Insulated Panel - Loading Deck Screen (Acoustic) MIP-04 Porcelain Stoneware Panel Cladding - Rainscreen PMC-01 Profile Metal Cladding WVP-01 Composite Wood Veneered Panel 	<ul style="list-style-type: none"> FGL-01 Glazing Assembly 1 FGL-02 Glazing Assembly 2 FGL-03 Glazing Assembly 3 FGL-04 Glazing Assembly 4 - Ballroom FGL-05 Glazing Assembly 5 FGL-06 Glazing Assembly 6 - Existing East Façade ICC FGL-07 Glazing Assembly 7 FGL-08 Glazing Assembly 8 FGL-09 Glazing Assembly 9 FGL-10 Glazing Assembly 10 - ABO FGL-11 Glazing Assembly 11 - Entry FGL-14 Glazing Assembly 14 	<ul style="list-style-type: none"> FLV-02 Class A Weatherproof Louvers - Concealed Frame 	<ul style="list-style-type: none"> AFG-01 Aluminum Flat Bar Grille AFG-02 Aluminum Flat Bar Grille - Horizontal EXM-01 Expanded Mesh Screen EXM-02 Expanded Mesh Screen 	<ul style="list-style-type: none"> ACP-02 Composite Aluminum Panel - Soffits CFC-01 Compressed Fibre Cement Sheet - Soffit LPC-02 Porcelain Panel Cladding - Soffit 	<ul style="list-style-type: none"> FCT-01 Colorbond Façade Flashing FCT-04 Colorbond Façade Flashing 	<ul style="list-style-type: none"> RFS-01 Metal Roof Sheeting RFS-02 Metal Roof Sheeting RFS-04 Re-Roofing (Parkside)

ARCHITECT - PRINCIPAL DESIGN CONSULTANT
HASSELL+POPULOUS
 HASSELL + POPULOUS PTY LTD ABN 346197317
 LEVEL 2, PIER 8/9
 23 HICKSON ROAD
 SYDNEY NSW 2000 AUSTRALIA
 T +61 2 9101 2000 F +61 2 9101 2100

- CONSULTANTS
- Robert Bird Group**
STRUCTURAL SERVICES
LEVEL 5, 9 CASTLEREAGH ST, SYDNEY NSW 2000
(02) 8246 3000
 - AECOM**
BUILDING / ENVIRONMENTAL SERVICES
LEVEL 21, 420 GEORGE ST, SYDNEY NSW 2000
(02) 9334 0000
 - ARMIS**
HYDRAULIC SERVICES
LEVEL 2, 9/24 HICKSON RD, MILLERS POINT NSW 2000
(02) 8036 8370
 - Hyder**
CIVIL / TRAFFIC SERVICES
51 HAYMARKET ST, NORTH SYDNEY NSW 2060
(02) 8907 9000

CLIENT
Lend Lease
 LEND LEASE BUILDING PTY LTD
 LEVEL 4, THE BOND, 30 HICKSON RD
 MILLERS POINT, NSW 2000
 (02) 9236 6111

PROJECT
DARLING HARBOUR LIVE
 ICC

DRAWING TITLE
SECTION 96
OVERALL ELEVATIONS

STATUS
SECTION 96

SCALE @ A3: 1/50 @ A2: 1/25 @ A1: 1/10
 PROJECT NUMBER: 003688 DRAWING NUMBER: CO_AR_D_400001 REV: D

FOR APPROVAL

CL: User Project\03688_CO_AR_D_400001.dwg

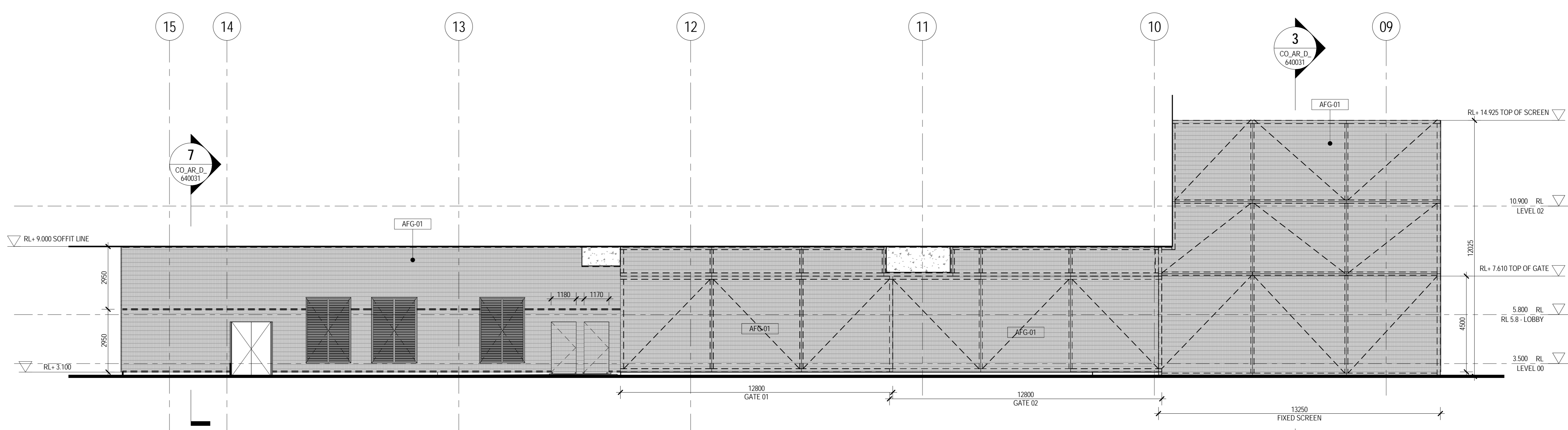
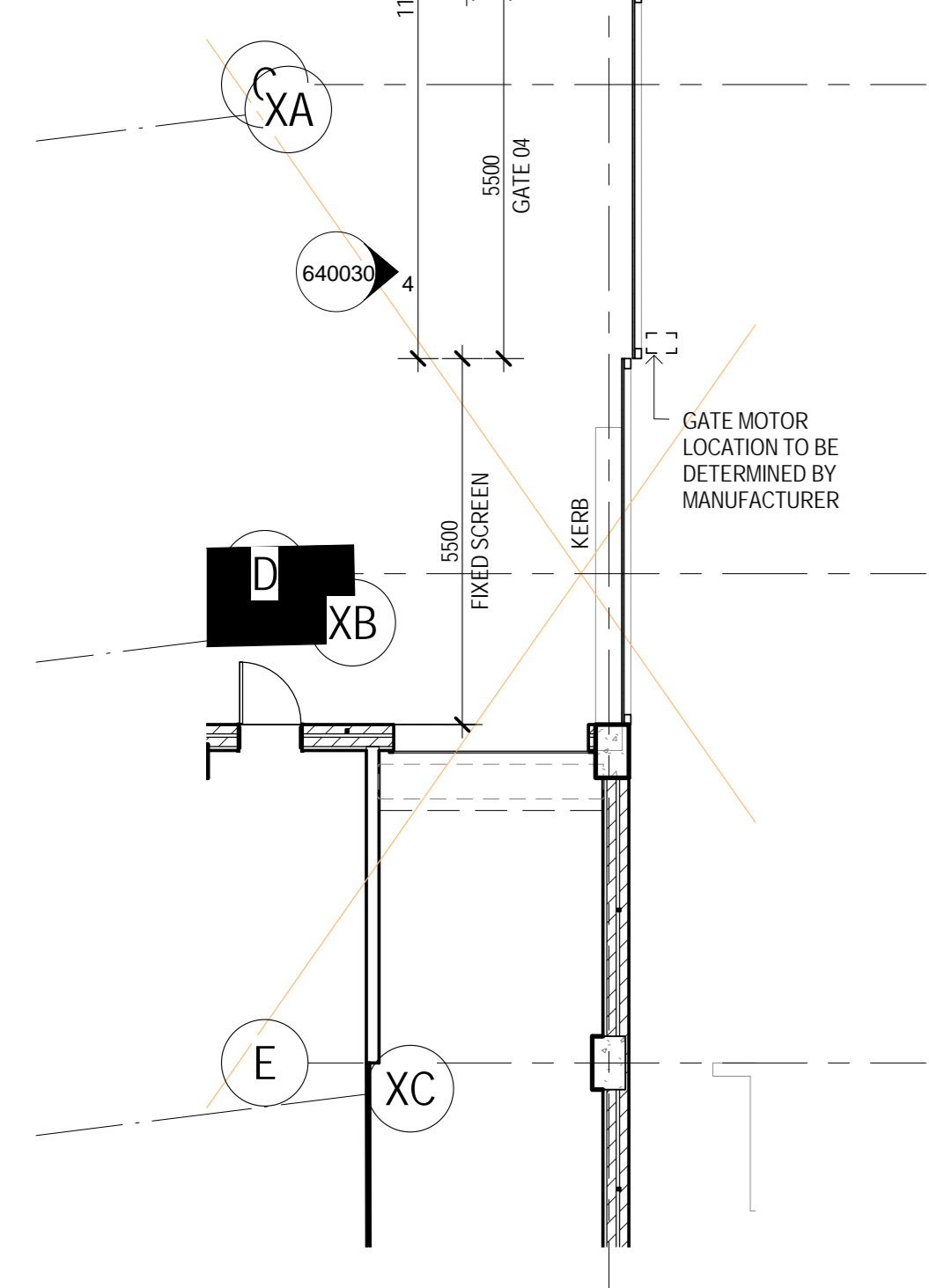
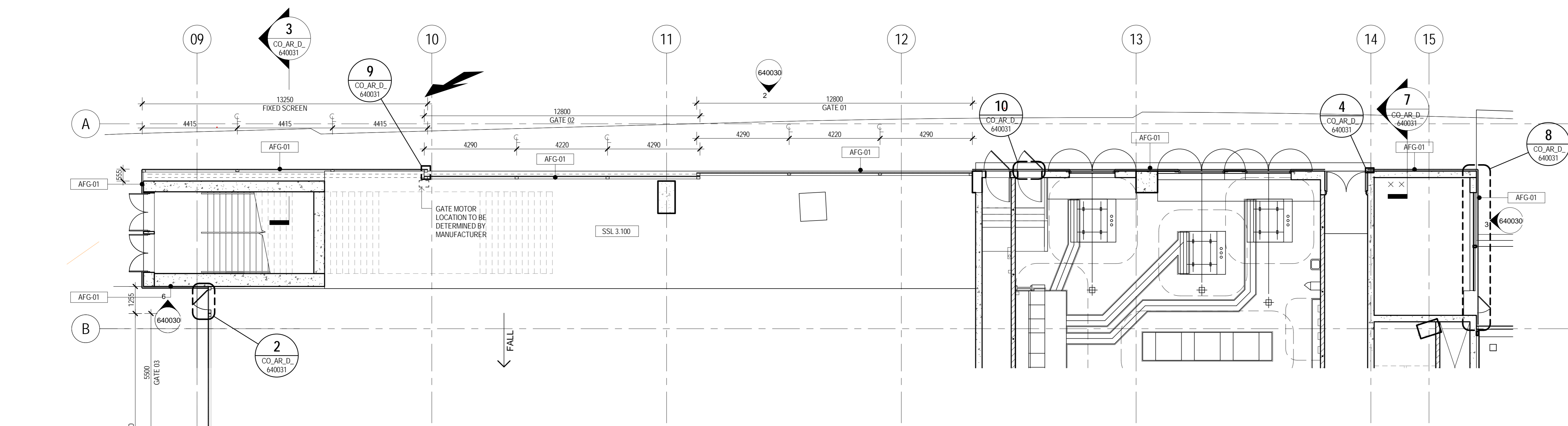

1 HI-LIGHT SCREEN PLAN - RL 3.5 - GROUND_ZONE 4
CO.AR.D. 200483 1:100

2 (DHT) ELEVATION - WEST 2
CO.AR.D. 640030 1:100

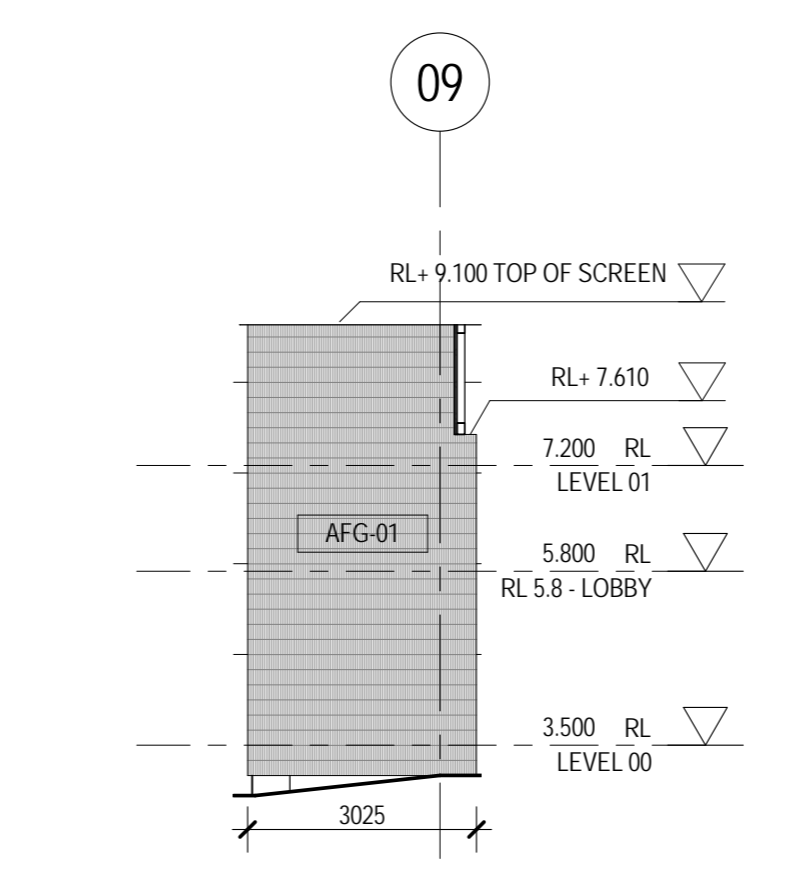
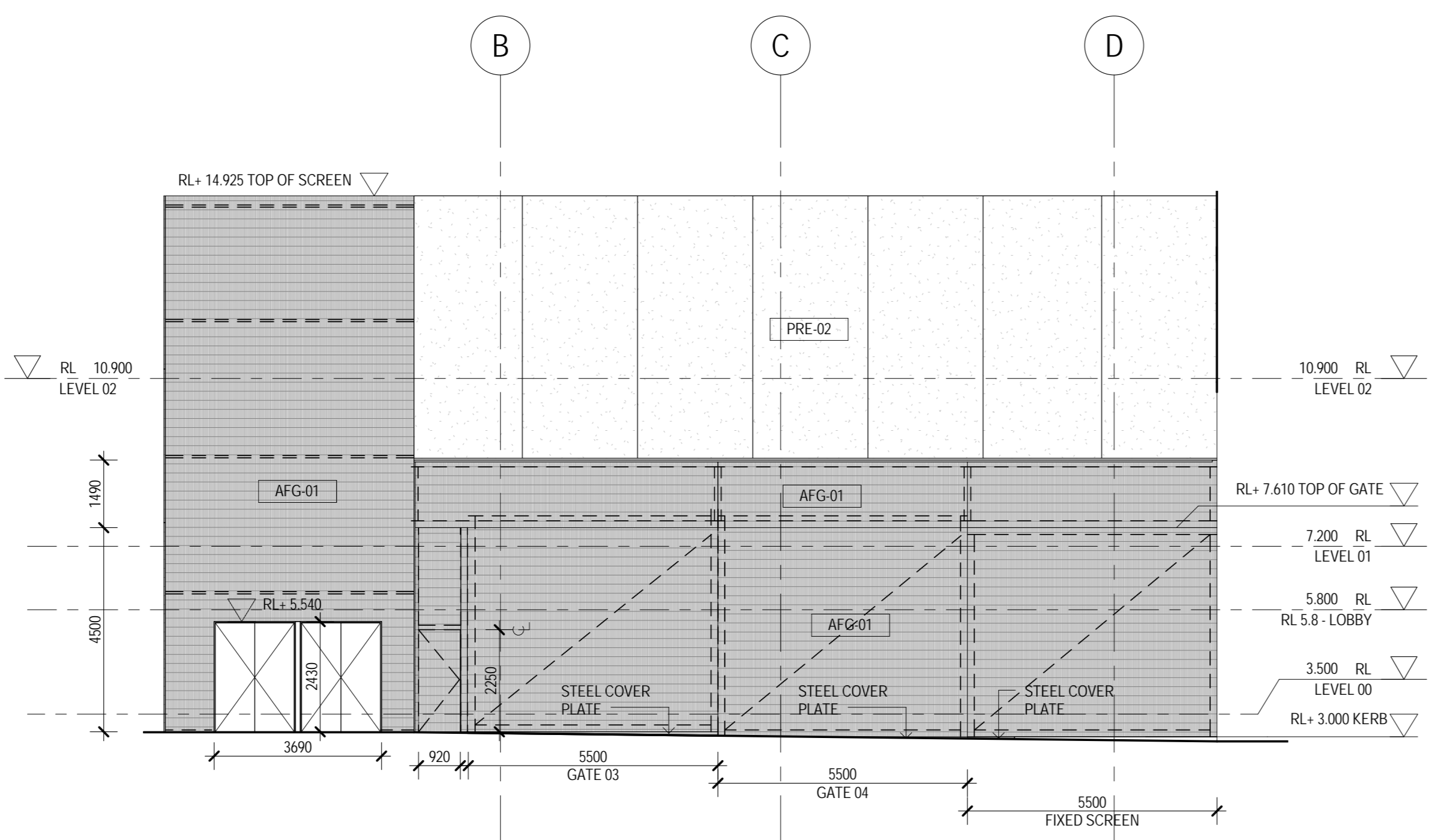
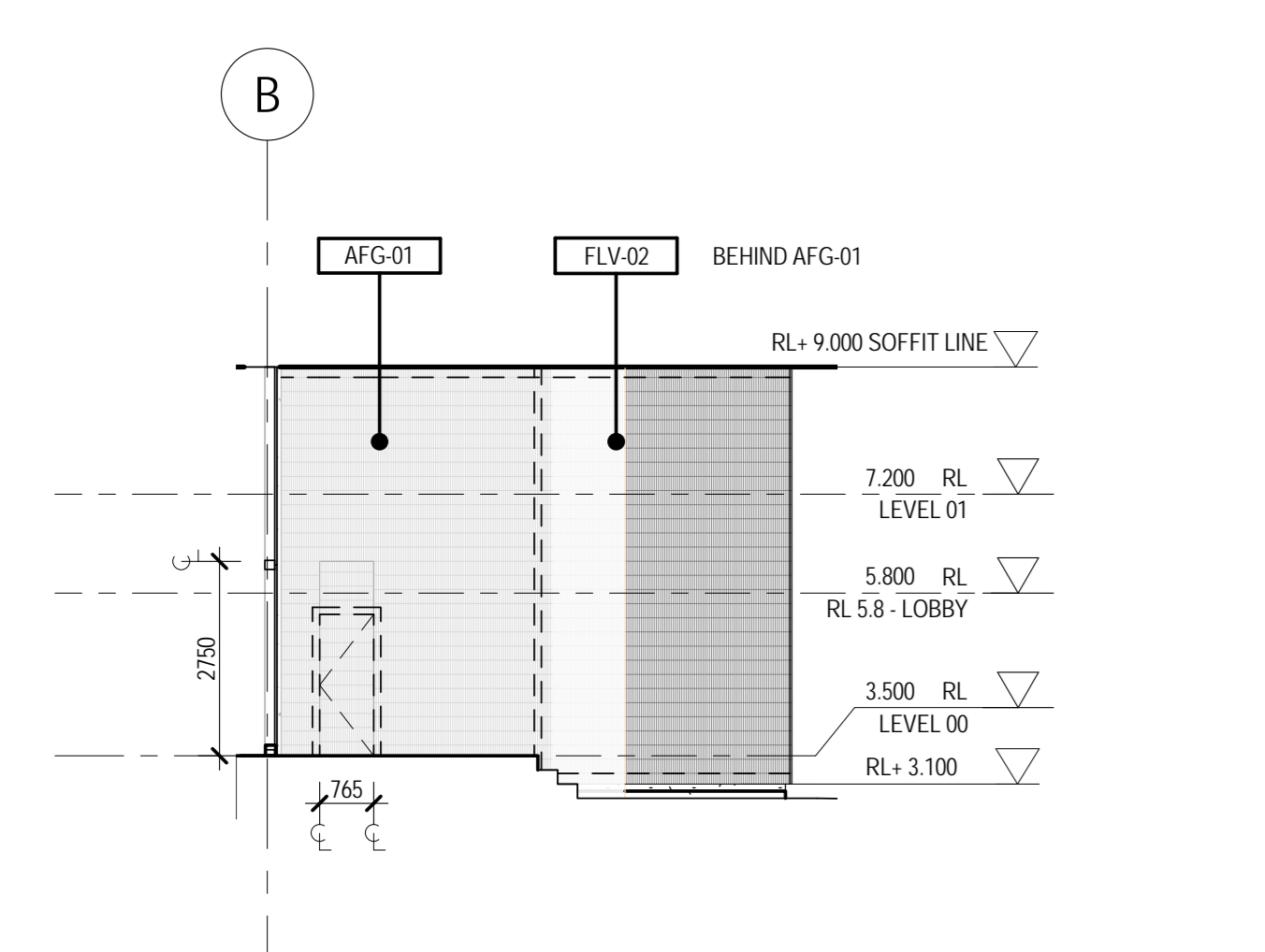

3 (DHT) ELEVATION - NORTH 3
CO.AR.D. 640030 1:100

4 (DHT) ELEVATION - SOUTH 2
CO.AR.D. 640030 1:100

6 (DHT) ELEVATION - SOUTH RETURN
CO.AR.D. 640030 1:100



HI-LIGHT SCREEN REFERENCE IMAGE

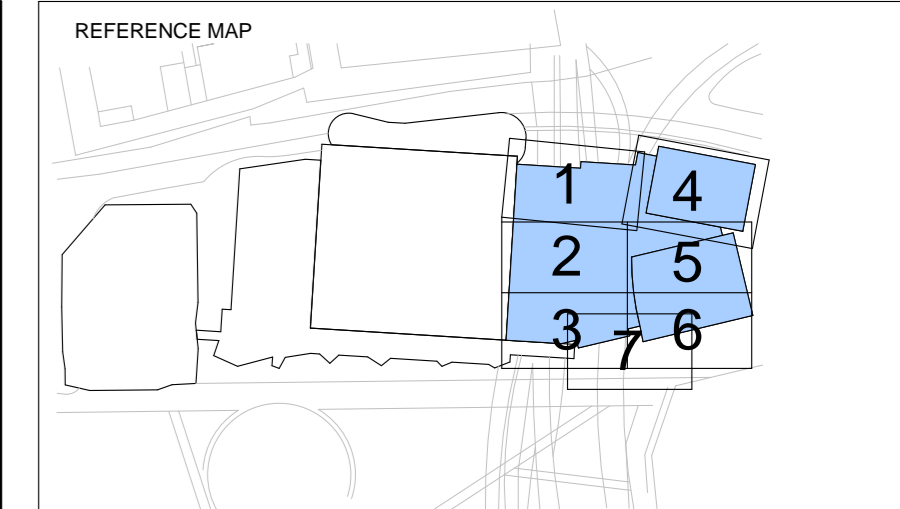

NOTES
 1. DO NOT SCALE DRAWINGS. WRITTEN DIMENSIONS GOVERN.
 2. ALL DIMENSIONS ARE IN MILLIMETRES UNLESS NOTED OTHERWISE.
 3. ALL DIMENSIONS SHALL BE VERIFIED ON SITE BEFORE PROCEEDING WITH THE WORK. HASSELL+POPULOUS SHALL BE NOTIFIED IN WRITING OF ANY DISCREPANCIES.
 4. THIS DRAWING MUST BE READ IN CONJUNCTION WITH ALL RELEVANT CONTRACTS, SPECIFICATIONS AND DRAWINGS.

© COPYRIGHT OF THIS DRAWING IS VESTED IN HASSELL+POPULOUS. 2014 HASSELL+POPULOUS PTY LTD
 THIS DRAWING IS AN UNCONTROLLED COPY UNLESS NOTED OTHERWISE.

REV	DESCRIPTION	DATE
A	AFG - BUILDING ENVELOPE	12.03.14
B	ISSUED FOR SECTION 96 APPLICATION	02.04.14

ARCHITECT - PRINCIPAL DESIGN CONSULTANT
HASSELL+POPULOUS
 HASSELL + POPULOUS PTY LTD ABN 346197317
 LEVEL 2, PIER 8/9
 23 HICKSON ROAD
 SYDNEY NSW 2000 AUSTRALIA
 T +61 2 9101 2000 F +61 2 9101 2100

- CONSULTANTS
- STRUCTURAL SERVICES**
LEVEL 5, 9 CASTLEREAGH ST, SYDNEY NSW 2000 (02) 8246 3000
 - BUILDING / ENVIRONMENTAL SERVICES**
LEVEL 2, 420 GEORGE ST, SYDNEY NSW 2000 (02) 9334 0000
 - HYDRAULIC SERVICES**
LEVEL 2, 9/24 HICKSON RD, MILLERS POINT NSW 2000 (02) 8036 8370
 - CIVIL / TRAFFIC SERVICES**
31/41 HALLAMER ST, NORTH SYDNEY NSW 2060 (02) 8907 9000

CLIENT
Lend Lease
 LEND LEASE BUILDING PTY LTD
 LEVEL 4, THE BOND, 20 HICKSON RD
 MILLERS POINT, NSW 2000
 (02) 9236 6111

PROJECT
DARLING HARBOUR LIVE
 ICC

DRAWING TITLE
SHEET 1 - DHT
GATE DETAILS

STATUS
SECTION 96

SCALE @ A1/50% @ A2	DRAWN	CO.ORD.	REVIEWED	APPROVED
1:100	JO	DH		
PROJECT NUMBER	DRAWING NUMBER	REV		
003688	CO_AR_D_640030	B		

FOR APPROVAL

C:\Users\pope\Documents\CO_AR_D_640030.dwg 12/29/14 12:29:01 PM

