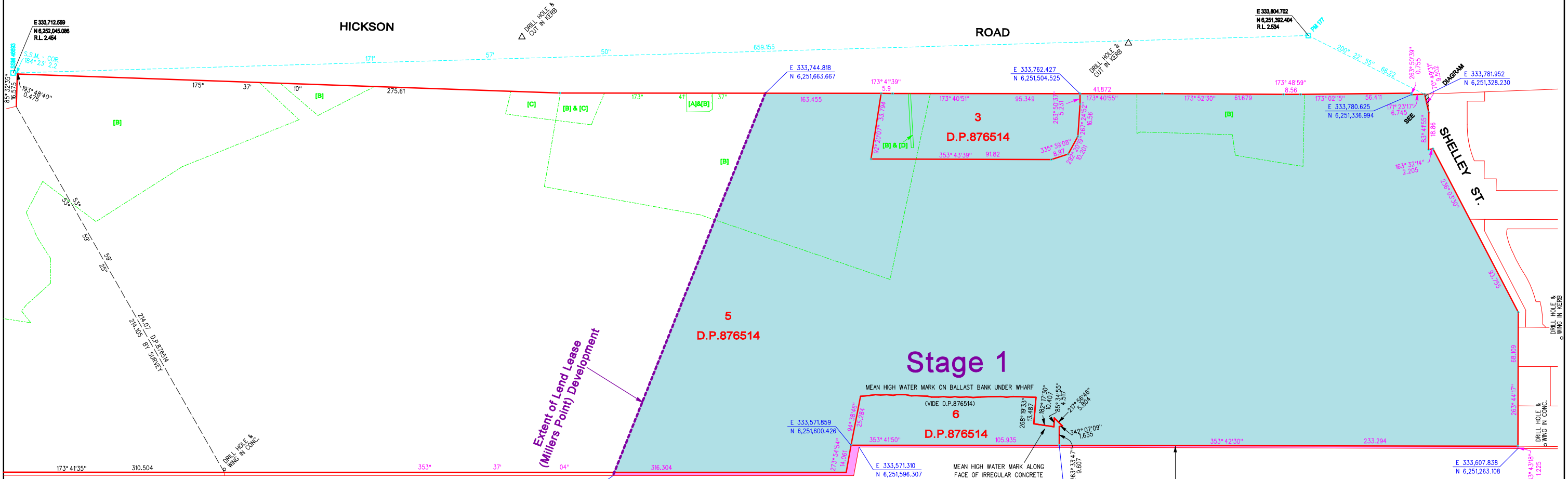

DIAGRAM
(NOT TO SCALE)



NOTES:
SEPP BLOCK DATA PLACED IN ACCORDANCE WITH RYGATE SURVEYORS REPORT AND SKETCH REF: "74141.REPORT" DATED: 17/4/2010

ORIGIN OF CO-ORDINATES: SSM 46693 IN HICKSON ROAD.
E 333 712.559
N 6252045.086
AZMUTH IS ON M.G.A. NORTH. DISTANCES ARE PLAIN DISTANCES CENTRED ABOUT SSM 46693

M.G.A. CO-ORDINATES OF OTHER PMS & SSM'S MUST BE ADJUSTED ABOUT SSM 46693 BEFORE BEING USED FOR CONTROL.

BEARINGS SHOWN RELATE TO M.G.A. NORTH.

THIS PLAN HAS BEEN CREATED AT A SCALE OF 1:1000 AND MAY NOT BE SATISFACTORY FOR OTHER PURPOSES. THE ACCURACY OF ANY ENLARGEMENT OR OTHER REPRODUCTION MAY BE LESS THAN THAT OF THE ORIGINAL.

COPYRIGHT © RYGATE & COMPANY PTY. LIMITED 2010.
NO PART OF THIS PLAN MAY BE REPRODUCED, COMMUNICATED, STORED IN A RETRIEVAL SYSTEM OR TRANSMITTED IN ANY FORM WITHOUT THE WRITTEN PERMISSION OF THE COPYRIGHT OWNER EXCEPT AS PERMITTED BY THE COPYRIGHT ACT 1968. ANY PERMITTED DOWNLOADING, ELECTRONIC STORAGE, DISPLAY, PRINT, COPY, REPRODUCTION OR COMMUNICATION OF THIS SURVEY SHOULD CONTAIN NO ALTERATION OR ADDITION TO THE ORIGINAL SURVEY.

AS INSTRUCTED BY ANDREW COLANGELO (BOVIS LEND LEASE) BEARINGS AND DISTANCES OF LINES SHOWN HEREIN HAVE BEEN MODIFIED TO REFLECT DIMENSIONS WITHIN A MICROSTATION CAD FILE AND NOT FROM THE CIVILCAD FILE FROM WHICH THEY HAVE ORIGINATED AND MAY HAVE SLIGHT VARIATIONS.

THE VARIATIONS ARE DUE TO ROUNDING ERRORS. THE REQUIREMENTS OF THE SURVEY PRACTICE REGULATIONS 2006 ARE THAT BEARINGS SHALL BE SHOWN TO THE NEAREST 5" AND DISTANCES TO THE NEAREST 5mm.

BEWARE
TO SATISFY THE LAND AND PROPERTY MANAGEMENT AUTHORITY SUBDIVISION PLANS WOULD NEED TO RELATE TO THE SURVEYED CIVILCAD BEARINGS AND DISTANCES WHICH WILL VARY WITH THE MICROSTATION DIMENSIONS.

LINE STYLE	LAYER NAME	DESCRIPTION
—	BOUNDARY	DENOTES LINE OF BOUNDARY OF LAND UNDER THE OWNERSHIP OF THE BARANGAROO DELIVERY AUTHORITY
- - -	ADJ.BOUNDARY	DENOTES LINE OF BOUNDARY OF ADJOINING PROPERTIES
- - - - -	DEVELOPMENT	DENOTES EXTENT OF LEND LEASE (MILLERS POINT) DEVELOPMENT
- - - - -	EASEMENT	DENOTES LINE OF EASEMENT FOR SEWERAGE PUMPING STATION (VIDE DP1080540) AND EASEMENT FOR DRAINAGE OF WATER (VIDE DEALING J 23252 AND DP106510)
- - - - -	RES.COND...CROWN	DENOTES APPROXIMATE POSITION OF RESERVATIONS AND CONDITIONS IN THE CROWN GRANT & LAND EXCLUDED MINERALS BY CROWN GRANT (VIDE DP876514)
■	BARANGAROO SOUTH PROJECT AREA	BARANGAROO SOUTH PROJECT AREA (LOT 3, LOT 5, PART LOT 6 D.P.876514 AND PART OF SHELLEY STREET AT CNR. OF HICKSON ROAD.)
■	ADJOINING PROJECT AREA	PART LOT 6 D.P.876514 ADJACENT IS PART OF BARANGAROO SOUTH PROJECT AREA
- - - - -	ROAD	DENOTES EXTENT OF LAND OWNERSHIP TO BE CONFIRMED WITH NSW GOVERNMENT.
▨	ROAD	DENOTES EXTENT OF LAND OWNERSHIP TO BE CONFIRMED WITH NSW GOVERNMENT.

NOTE: THE EDGE OF THE WHARF DOES NOT COINCIDE WITH THE BOUNDARY LINES. FURTHER DETAILED SURVEY WORK IS REQUIRED

- [A] - EASEMENT FOR SEWERAGE PUMPING STATION VARIABLE WIDTH (D.P.1080540)
- [B] - RESERVATIONS & CONDITIONS IN THE CROWN GRANT (S)
- [C] - LAND EXCLUDES MINERALS BY CROWN GRANT
- [D] - EASEMENT FOR DRAINAGE 1.22 WIDE (J 23252 & D.P.106510)

REV.	DATE	AMENDMENTS
A	07/12/2010	ISSUE FOR DESIGN INFORMATION

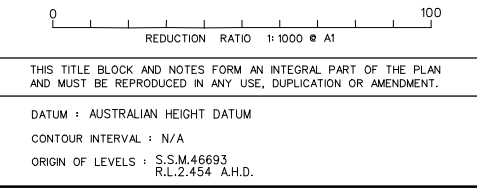

RYGATE & COMPANY PTY. LIMITED
REGISTERED LAND SURVEYORS
81 YORK STREET, SYDNEY 2000
MEMBER OF ASSOCIATION OF CONSULTING SURVEYORS

PHONE 9262 6800 FAX 9262 6843
ABN 61 001 204897
www.rygate.com.au
Email: surveyors@rygate.com.au

SURVEYOR	DRAWN	CHECKED	APPROVED
-	CAD	A.F.	A.F.

CLIENT	LEND LEASE (Millers Point) PTY. LTD.
LOCALITY	BARANGAROO
L.G.A.	CITY OF SYDNEY

SITE DESCRIPTION FOR DESIGN PURPOSES SHOWING BARANGAROO SOUTH SITE LOTS 3, 5 AND PART LOT 6 D.P.876514			
REFERENCE No.	PLAN No.	DATE	SHEET No.
74556		7/12/2010	OF - SHEETS

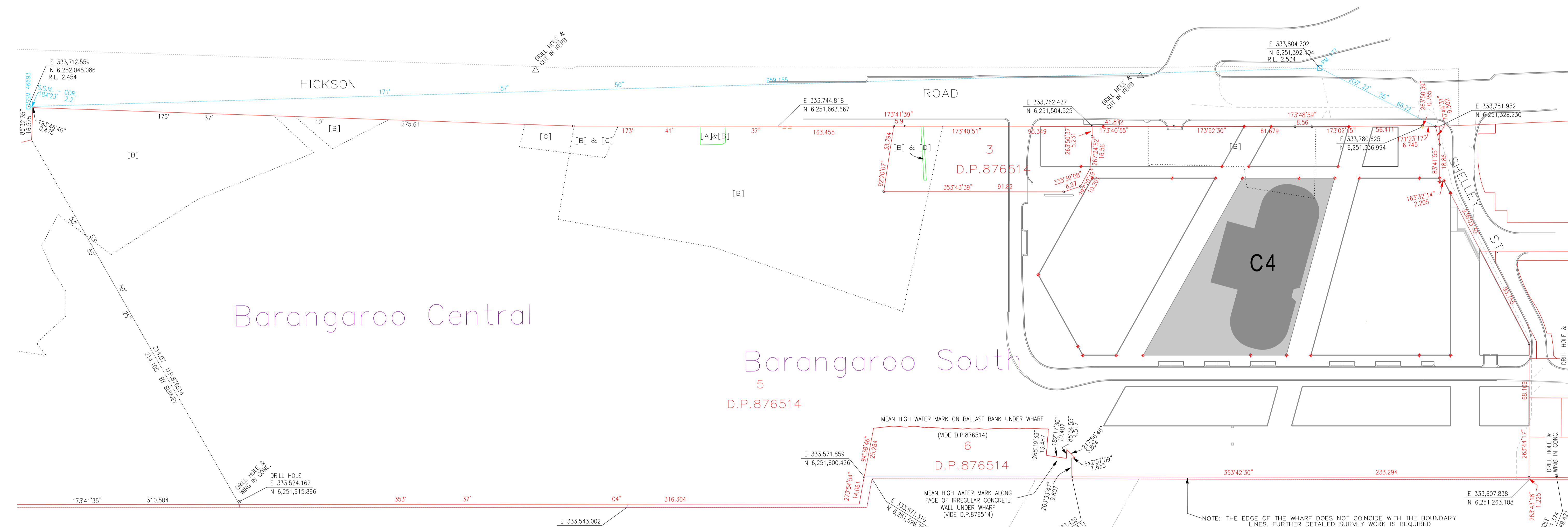
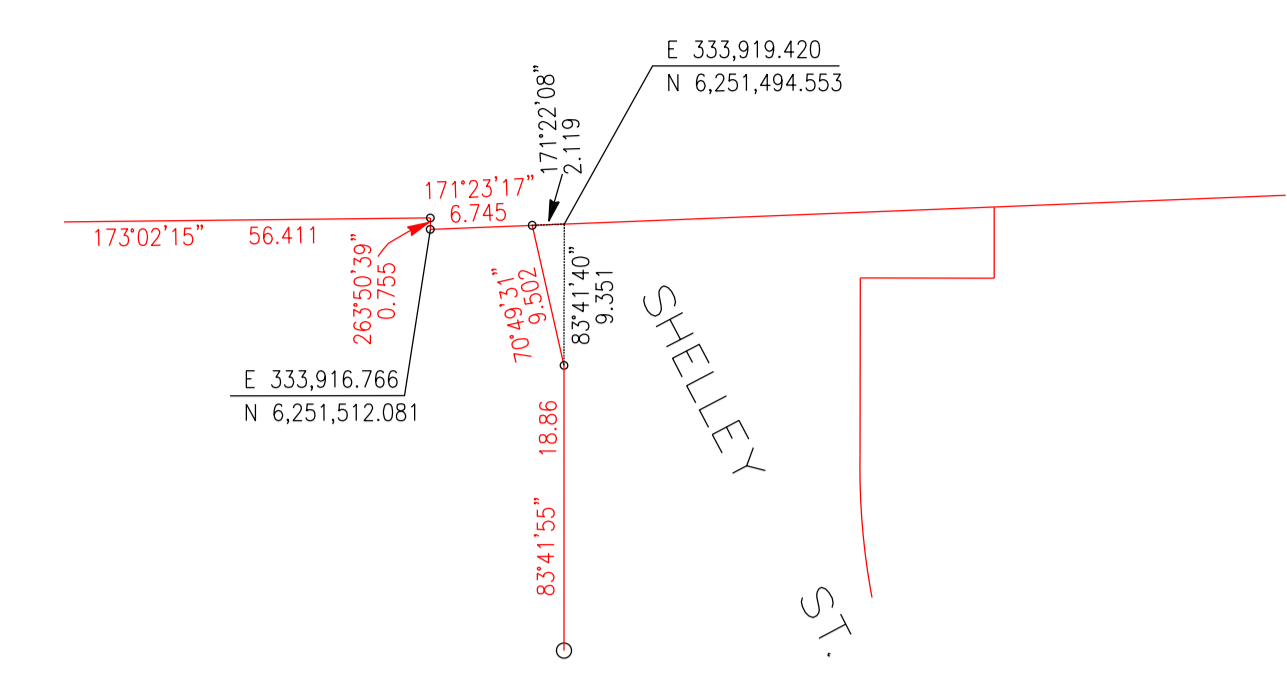
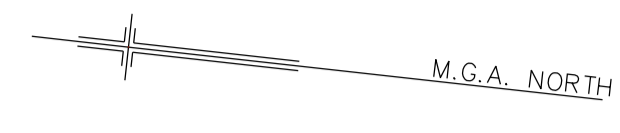

Barangaroo Central

Barangaroo South
5
D.P.876514

LEGEND		
LINE STYLE	LAYER NAME	DESCRIPTION
	BOUNDARY	DENOTES LINE OF BOUNDARY OF LAND UNDER THE OWNERSHIP OF THE BARANGAROO DELIVERY AUTHORITY
	ADJ BOUNDARY	DENOTES LINE OF BOUNDARY OF ADJOINING PROPERTIES
	DEVELOPMENT	DENOTES EXTENT OF LEASE (MILLERS POINT) DEVELOPMENT
	EASEMENT	DENOTES LINE OF EASEMENT FOR SEWERAGE PUMPING STATION (VIDE DP1080540) AND EASEMENT FOR DRAINAGE OF WATER (VIDE DEALING J.23252 AND DP106510)
	RES.COND._CROWN	DENOTES APPROXIMATE POSITION OF RESERVATIONS AND CONDITIONS IN THE CROWN GRANT & LAND EXCLUDED MINERALS BY CROWN GRANT (VIDE DP876514)
	BARANGAROO SOUTH DEVELOPMENT AREA	BARANGAROO SOUTH DEVELOPMENT AREA (LOT 3, LOT 5, PART LOT 6 D.P.876514 AND PART OF SHELLEY STREET AT CNR. OF HICKSON ROAD.)

ORIGIN OF CO-ORDINATES: SSM 46693 IN HICKSON ROAD.
E 333 712.559
N 6252045.086
AZIMUTH IS ON M.G.A. NORTH. DISTANCES ARE PLAIN DISTANCES CENTRED ABOUT SSM 46693

M.G.A. CO-ORDINATES OF OTHER P.M'S & SSM'S MUST BE ADJUSTED ABOUT SSM 46693 BEFORE BEING USED FOR CONTROL.

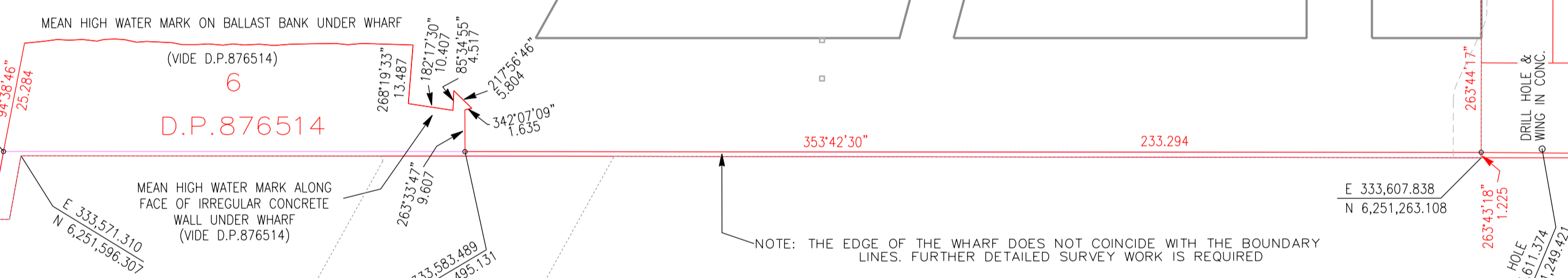

NOTE: THE EDGE OF THE WHARF DOES NOT COINCIDE WITH THE BOUNDARY LINES. FURTHER DETAILED SURVEY WORK IS REQUIRED

- [A] - EASEMENT FOR SEWERAGE PUMPING STATION VARIABLE WIDTH (D.P.1080540)
- [B] - RESERVATIONS & CONDITIONS IN THE CROWN GRANT (G)
- [C] - LAND EXCLUDES MINERALS BY CROWN GRANT
- [D] - EASEMENT FOR DRAINAGE 1.22 WIDE (J.23252 & D.P.106510)

INDICATIVE LAYOUT ONLY