



TITLE Water Management Plan  
DOC ID ENV 00002 – Water Management Plan  
SITE Chain Valley Colliery



**Environmental Management System**  
**Chain Valley Colliery**  
**Water Management Plan**

<b>Reviewed</b>	
	Lachlan McWha – Delta Coal
<b>Authorised by:</b>	
	Lachlan McWha – Delta Coal Environmental Compliance & Approvals Coordinator
<b>Date:</b>	16 January 2024

Review Date	Next Review Date	Revision No	Document Owner	Page
16/01/2024	16/01/2027	7	Environmental Compliance and Approvals Coordinator	Page 1 of 75

**DOCUMENT UNCONTROLLED WHEN PRINTED**

## TABLE OF CONTENTS

1	Introduction.....	4
1.1	Purpose .....	4
1.2	Background .....	4
1.3	Operations.....	4
1.4	Consultation .....	5
2	Summary of the Statutory Approval Requirements .....	8
2.1	Key Legislation, Policy and Guidelines .....	8
2.2	Development Consent (SSD-5465).....	8
2.3	Mining Leases.....	9
2.4	Environmental Protection License (EPL 1770) .....	9
2.5	Maximum Harvestable Right Dam Capacity.....	9
3	Water Balance .....	10
3.1	Water Balance Model .....	10
3.2	Data (Model Inputs and Outputs) .....	10
3.2.1	Rainfall Runoff.....	10
3.2.2	Evaporation .....	11
3.2.3	Underground Water Extraction.....	11
3.2.4	Pollution Control Dam Characteristics .....	12
3.2.5	Loss of Water through Coal Export .....	14
3.2.6	Additional Data .....	14
3.3	Water Balance Results .....	15
3.3.1	Expected Discharge from Chain Valley Colliery.....	15
3.3.2	Potable Water Use .....	16
3.4	Water Supply and Security.....	16
4	Surface Water Management .....	17
4.1	Overview of Water Management System.....	17
4.2	Potable water .....	17
4.3	Underground Water.....	17
4.4	Surface Water Catchments and Controls.....	18
4.4.1	Catchment 1 .....	20
4.4.2	Catchment 2 .....	20
4.4.3	Catchment 3 .....	21
4.4.4	Catchment 4.....	21
4.5	Management of Pollution Control Dams .....	21
4.6	Erosion and Sediment Control / Ground Disturbance .....	22
4.6.1	Soils .....	22
4.6.2	Potential Impacts .....	22
4.6.3	Standard Erosion and Sediment Controls .....	22
4.6.4	Construction Erosion Management Plan .....	22
4.7	Water Savings .....	23
4.8	Acid Sulfate Soils .....	23
4.9	Sewerage Disposal and Management.....	24
4.10	The Oil Water Separator .....	24
5	Monitoring.....	25
5.1	Baseline Surface Water Quality Monitoring Data .....	25
5.2	Impact Assessment Criteria and Trigger Levels.....	29
5.2.1	Surface Waters.....	29
5.2.2	Underground Water .....	29
5.3	Surface Water Monitoring and Frequency.....	29
5.4	Stream Health Channel Flow and Riparian Vegetation Monitoring.....	31
5.5	Groundwater Monitoring Program .....	31

Review Date	Next Review Date	Revision No	Document Owner	Page
16/01/2024	16/01/2027	7	Environmental Compliance and Approvals Coordinator	Page 2 of 75

5.6	Additional Operational Monitoring.....	32
5.7	Inspections and Maintenance .....	32
5.7.1	Sediment Dams .....	33
5.7.2	Drainage Channels .....	33
5.7.3	Temporary ESC Structures .....	33
5.7.4	Roads and Hard Stand Areas.....	34
5.7.5	Washbay Oil Water Separator.....	34
5.7.6	Compressor Condensate Oil Water Separator .....	34
5.7.7	Carpark.....	34
5.7.8	Underground Flow Monitoring Devices .....	34
5.8	Data Recording and Publication .....	34
6	Reporting.....	35
6.1	Regular Reporting .....	35
6.2	Annual Review.....	35
6.3	Incident or Non-Compliance Response and Reporting .....	35
7	Stakeholder Management, Response and Training.....	37
7.1	Complaint Protocol .....	37
7.2	Independent Review .....	37
7.3	Dispute Resolution .....	37
7.4	Training, Awareness and Competence.....	38
8	Audit and Review.....	39
8.1	Overview .....	39
8.2	Audits .....	39
9	Records and Document Control .....	40
9.1	Records.....	40
9.2	Document Control.....	40
10	Roles and Responsibilities .....	42
10.1	Responsibilities .....	42
11	References & Associated Documents.....	43
12	Definitions .....	45
	Appendix 1: Groundwater Management Plan (GwMP)	
	Appendix 2: Consultation	
	Appendix 3: Development Consent and EPL Summary	
	Appendix 4: Standard Erosion and Sediment Controls	
	Appendix 5: Acid Sulfate Soil Risk Map Review	
	Appendix 6: Surface Water Assessment, GSS Environmental 2013	
	Appendix 7: EPL 1770 Water Quality Monitoring Results	
	Appendix 8: 2010-2015 Licensed Discharge Point Water Quality Monitoring	
	Appendix 9: Water Management TARP	
	Appendix 10: Environmental Incident Categories Matrix	

Review Date	Next Review Date	Revision No	Document Owner	Page
16/01/2024	16/01/2027	7	Environmental Compliance and Approvals Coordinator	Page 3 of 75

## 1 Introduction

### 1.1 Purpose

The Water Management Plan (WMP) addresses the requirements for Development Consent SSD-5465 as modified (MOD 4) and EPL 1770.

The purpose of the WMP is to:

- guide the management of surface and groundwater resources throughout the operational life of the mine;
- address the relevant conditions of the development consent;
- meet the requirements of EPL 1770, including Pollution Reduction Programs (PRP's) that have been implemented on site;
- address the relevant commitments made within the Surface Water Assessment (SWA) (GSSE, 2013) and Environmental Impact Statement (EIS) (EMM, 2013); and
- address legislative requirements and guidelines relevant to the WMP.

The WMP incorporates the following components as required by SSD-5465:

- a Water Balance;
- a description of Surface Water Management;
- a Surface Water Monitoring Plan;
- a Ground Water Monitoring Plan; and
- a Water Management Review.

### 1.2 Background

Chain Valley Colliery (CVC) is an underground coal mine located on the southern side of Lake Macquarie approximately 60 km south of Newcastle and 80 km north of Sydney (see **Figure 1**). The pit-top is located approximately 1 km south-east of the township of Mannering Park at the southern extent of Lake Macquarie.

In August 1960, J&A Brown and Abermain Seaham Collieries Ltd commenced clearing the present site with drift and shaft sinking starting a few months later. Production of coal from the Wallarah Seam, commenced with the first delivery to the adjacent Delta Electricity's Vales Point Power Station (VPPS) in April 1963.

As of 1 April 2019, Great Southern Energy Pty Ltd (trading as Delta Coal, DC) own and operate the two underground coal mines, CVC and Mannering Colliery (MC). Mining is currently undertaken at CVC, with the coal being transported underground to MC where the coal is crushed and screened and sent directly to VPPS.

### 1.3 Operations

CVC is an underground coal mine which extracts coal through both first and secondary workings. ROM coal from both the first and second workings is transported out of the mine via a conveyor system to Mannering Colliery for processing.

The surface infrastructure comprises limited facilities at the 14 hectare pit top area adjacent to the Vales Point Power Station, off Construction Road at Mannering Park, and another 0.3 hectare area at the ventilation facility situated at Summerland Point. Both the pit top and ventilation facilities have remained largely unchanged since their establishment.

The above operations have potential impacts which were addressed in the SWA (GSSE, 2013). To address these, the SWA (GSSE, 2013) identified the following key objectives for surface water management at CVC:

- the prevention of the flow of pollutants into watercourses and the sedimentation on receiving waters, being Swindles Creek to the east of the pit top and Lake Macquarie;
- the control of discharges from the site to ensure that all discharges are within the water volume and quality criteria set out in EPL 1770;
- to minimise site potable water usage requirements and maximise runoff water reuse; and
- to ensure there is sufficient water available to meet Chain Valley Colliery's water requirements.

Review Date	Next Review Date	Revision No	Document Owner	Page
16/01/2024	16/01/2027	7	Environmental Compliance and Approvals Coordinator	Page 4 of 75

#### 1.4 Consultation

The original WMP (GSSE, 2012) was prepared in consultation with the former NSW Office of Water (NOW), DTIRIS (Division of Resources & Energy (DRE)) and Wyong Shire Council. The previous WMP (GSSE, 2012) was submitted on the 23 August 2012 and approved by the Director-General on the 6 November 2012.

The 2015 revision of the WMP was prepared in consultation with the (former) NOW and the Environment Protection Authority (EPA) and incorporates outcomes of correspondence with EPA in relation to the variation of the EPL. Comments on the WMP were received from NOW on the 5 December 2014 and requested a change to the groundwater drawdown trigger to 2m over a 2-month period, which is consistent with the minimal impact considerations of the NSW Aquifer Interference Policy, this change has been made within the Groundwater Management Plan (**Appendix 1**).

Comments were also sought from the EPA and subsequently requested via email in December 2014. On the 12 June 2015 the EPA responded stating that “The Environment Protection Authority (“EPA”) encourages the development of such plans to ensure that proponents have met their statutory obligations and designated environmental objectives. However, EPA does not review these documents as our role is to set environmental objectives for environmental / conservation management, not to be directly involved in the development of strategies to achieve those objectives.

In accordance with Schedule 3, Condition 18 of development consent SSD-5465 the December 2019 WMP review was prepared by suitably qualified and experienced persons, Sally Callander (EMM Consulting), Andrew Dawkins (Geoterra) and Chris Armit (EMM Consulting), whose appointment has been endorsed by the Planning Secretary.

A draft revision of the WMP was provided to DPIE - Water, EPA and DPIE on 26 November 2019 and a further review was provided in May 2020 associated with the Miniwall S4 Extraction Plan.

A review has been undertaken:

- after the approval of SSD5465 Mod 3 (approved in June 2020);
- for the submission of the Miniwall S5 and Northern Pillar area extraction plan (December 2020) with an updated Groundwater Management Plan; and
- Following the approval of SSD5465 Mod 4 (approved August 2021) references to Development Consent SSD-5465 were made to the document. The SEE prepared to accommodate Mod 4 to SSD-5465, there were no changes to extraction rates or surface infrastructure, or intensification of activities proposed by the modification and, therefore, water resources will not be impacted. Considering consultation with stakeholders on the WMP was undertaken for the Miniwall S5 and Northern Pillar area extraction plan (December 2020) further consultation was not undertaken beyond Planning Secretary approval.
- Following the completion of the 2022 Independent Environmental Audit.

A summary of the comments received and amendments subsequently made to the document (V7) prior to finalisation are detailed in **Table 1**. Evidence of consultation is provided in **Appendix 2**. The groundwater management plan section of this plan was approved by DPE on the 6 April 2021 as part of the Miniwall S5 and Northern Pillar Area extraction plan (**Appendix 1**).

**Table 1: Consultation Summary**

Stakeholder	Comments	Response/Action
NSW EPA	<i>The EPA has reviewed the Site Water Management Plan (SWMP) and has no specific comments to make on its content. The EPA considers that the SWMP is broadly consistent with the current requirements of EPL 1770.</i>	Nil

Review Date	Next Review Date	Revision No	Document Owner	Page
16/01/2024	16/01/2027	7	Environmental Compliance and Approvals Coordinator	Page 5 of 75



TITLE Water Management Plan  
DOC ID ENV 00002 – Water Management Plan  
SITE Chain Valley Colliery

Stakeholder	Comments	Response/Action
DCCEEW – Water Group	<i>Include a summary of maximum predicted groundwater take currently and ongoing to demonstrate sufficient entitlement is held.</i>	Addressed in Section 3.2. with information from Chain Valley Colliery’s most recent Groundwater Impact Assessment.

Review Date	Next Review Date	Revision No	Document Owner	Page
16/01/2024	16/01/2027	7	Environmental Compliance and Approvals Coordinator	Page 6 of 75

**DOCUMENT UNCONTROLLED WHEN PRINTED**



Figure 1: Regional Context

Review Date	Next Review Date	Revision No	Document Owner	Page
16/01/2024	16/01/2027	7	Environmental Compliance and Approvals Coordinator	Page 7 of 75

DOCUMENT UNCONTROLLED WHEN PRINTED

## 2 Summary of the Statutory Approval Requirements

### 2.1 Key Legislation, Policy and Guidelines

A number of legislative requirements, government policies and guidelines relating to water management are applicable and have been addressed in detail within the SWA (GSSE, 2013). The key items of legislation and the relevant approval documents to this WMP are:

- *Water Act 1912 and Water Management Act 2000* - LakeCoal applied for a 4,443 ML/year groundwater license on the 5<sup>th</sup> October 2011 under the *Water Act, 1912* to pump water from the underground workings to the sedimentation and pollution control ponds at the pit top. The license (WAL41508) was subsequently granted on the 12 March 2013;
- *Protection of the Environment Operations Act 1997* (POEO Act) - Chain Valley Colliery has an existing EPL 1770 under the POEO Act for the discharge of water from site;
- *Environmental Planning and Assessment Act 1979* (EP&A Act) - On 23<sup>rd</sup> December 2013 development consent SSD-5465 was issued for the *Chain Valley Extension Project*, which has been modified twice by approval on the 27 November 2014 and 16 December 2015; and
- *Mining Act 1992* – Delta Coal holds numerous mining authorities under the Mining Act 1992, a list of all leases held is contained within the Environmental Management Strategy (OMP-D-16374), the most relevant for the WMP is Mining Purposes Lease 1349 as it pertains to the surface facilities area.

The relevant aspects of these approval documents are addressed further below.

Key policies and guidelines which are relevant to the preparation and implementation of this WMP include:

- ANZG 2018. Australian and New Zealand Guidelines for Fresh and Marine Water Quality. Australian and New Zealand Governments and Australian state and territory governments, Canberra ACT, Australia. Available at [www.waterquality.gov.au/anz-guidelines](http://www.waterquality.gov.au/anz-guidelines);
- Department of Environment and Conservation (DEC), Approved Methods for the Sampling and Analysis of Water Pollutants in NSW, March 2004;
- Managing Urban Stormwater: Soils and Construction (the Blue Book), Volume 1 and Volume 2E – Mines and Quarries (Landcom, 2004 and Department of Environment and Climate Change (DECC), 2008;
- NSW Water Quality and River Flow Objectives, September 1999;
- NSW State Rivers and Estuaries Policy, 1993;
- NSW Groundwater Quality Protection Policy, adopted in 1998;
- The NSW State Groundwater Dependent Ecosystems Policy, adopted in 2002;
- NSW Groundwater Quantity Management Policy;
- Australian Government, Charter: National Water Quality Management Strategy, 2018;
- Australian and New Zealand Environment Conservation Council (ANZECC) and the Agriculture and Resource Management Council of Australia and New Zealand (ARMCANZ), National Guidelines for Sewerage Systems - Effluent Management, 1997; and
- NSW Department of Environment and Conservation (DEC), Environmental Guidelines: Use of Effluent by Irrigation, 2004.'

### 2.2 Development Consent (SSD-5465)

This plan has been prepared in accordance with Schedule 3, Condition 21 of SSD-5465, which states the requirements of the WMP and what it must address. Surface and groundwater related requirements of SSD-5465, including specific requirements that are to be addressed in this plan, and where they are addressed, are detailed in **Appendix 3**.

Review Date	Next Review Date	Revision No	Document Owner	Page
16/01/2024	16/01/2027	7	Environmental Compliance and Approvals Coordinator	Page 8 of 75

In accordance with Schedule 2, Conditions 2 and 2A, in addition to carrying out the works in accordance with the conditions of SSD-5465, DC will also carry out works generally in accordance with the Environmental Impact Statement (EIS), Statement of Environmental Effects (SEE) (Mod 1), SEE (Mod 2), SEE (Mod 3), SEE (Mod 4) Project Layout Plans and Statement of Commitments.

### 2.3 Mining Leases

MPL 1349, is the most relevant lease to this WMP as MPL 1349 relates to the surface facilities. MPL 1349 contains the following provision with respect to surface water management.

*2. The proponent shall implement all practical measures to prevent and/or minimise any harm to the environment that may result from the construction, operation or rehabilitation of the development.*

*18. Operations must be carried out in a manner that does not cause or aggravate air pollution, water pollution (including sedimentation) or soil contamination or erosion, unless otherwise authorised by a relevant approval, and in accordance with an accepted Mining Operations Plan. For the purpose of this condition, water shall be taken to include any watercourse, waterbody or groundwater and perform any instructions given by the Director-General in this regard.*

### 2.4 Environmental Protection License (EPL 1770)

CVC operates under EPL 1770 issued by the Environment Protection Authority (EPA) under the POEO Act. The EPL has been modified a number of times, most recently in August 2022 for the transfer from Lake Coal Pty Ltd to Great Southern Energy Pty Ltd (trading as Delta Coal). Water related requirements of the EPL, including specific requirements that are to be addressed in this management plan and section references within the WMP are detailed in **Appendix 3**.

### 2.5 Maximum Harvestable Right Dam Capacity

Under the NSW *Water Management Act 2000*, landholders are permitted to capture, store and use a portion of the rainfall runoff on their property. The right to harvest rainfall is determined by geographic location and is typically 10% of the total rainfall runoff for the property and storage is calculated under the Maximum Harvestable Right Dam Capacity (MHRDC) provision. Dams that exceed this capacity or are greater than a certain size must be licenced.

Where dams are used to control pollution or effluent, there are exemptions to the licencing requirements. This is the case for the pollution control dams at CVC where the dams are exempt from the MHRDC calculation.

Review Date	Next Review Date	Revision No	Document Owner	Page
16/01/2024	16/01/2027	7	Environmental Compliance and Approvals Coordinator	Page 9 of 75

### 3 Water Balance

A comprehensive site water balance has been prepared for the site and is described in detail within the SWA (GSSE, 2013). This section of the WMP provides a summary of the water balance to enable the key inputs and outputs to be understood along with the water balance results. It also describes the implications of the proposed changes to site water management described in **Section 4.4**.

For more detailed information on the site water balance refer to the SWA (GSSE, 2013).

#### 3.1 Water Balance Model

A detailed ‘daily time-step’ water balance model was used to represent the Chain Valley Colliery water balance using GoldSim Version 10.50 (GoldSim Technology Group LLC). This software is a graphical, object-oriented system simulation software for completing either static or dynamic systems. GoldSim is commonly used to undertake ‘daily time step’ water balance simulations for coal mines within NSW due its enhanced modelling capability and flexibility compared to spreadsheet models that have predominately been used in the past. The Chain Valley Colliery water cycle, as simplified and modelled in GoldSim is shown in the schematic water flow diagram as shown on **Figure 2**.

#### 3.2 Data (Model Inputs and Outputs)

##### 3.2.1 Rainfall Runoff

The dataset developed for the water balance used information from the Wyee and Norah Head weather stations. There are other stations in the general vicinity, however these stations were selected due to their proximity to the CVC and length and completeness of the data, which together, provide over 100 years of rainfall data.

The pit top area was segregated into four distinct catchments which were further broken up into eight sub-catchments for the purpose of the CVC water balance.

The daily step GoldSim model was used to estimate the surface water runoff from different sub catchments at the pit top area. The runoff coefficients adopted are considered conservative but reflect the large impermeable area in the catchment which includes laydown areas, compacted roads and coal stockpile areas. The free water surfaces of the pollution control dams and the roofed areas were modelled as completely impervious areas, capturing all precipitation.

Catchment areas as modelled within the GoldSim model are provided in **Table 2**.

**Table 2: Pit Top Catchment Areas**

Major Catchment Name	Sub-Catchment Name	Catchment Area (ha)
Carpark (Catchment 1)	Carpark (not modelled)	NA
Storage Yard (Catchment 2)	Oil Water Separator	0.15
	Workshop (Roof)	0.24
	Old Bath House (Roof)	0.11
	Pit Top Storage Yard	3.03
Stockpile (Catchment 3)	CHP Stockpile	5.34
Pollution Control Dams (Catchment 4)	Dams D1 to D6	0.41
	Dams D7 to D13	1.97
<b>Total catchment reporting to pollution control dams</b>		<b>11.25</b>

Review Date	Next Review Date	Revision No	Document Owner	Page
16/01/2024	16/01/2027	7	Environmental Compliance and Approvals Coordinator	Page 10 of 75

(excluding carpark)

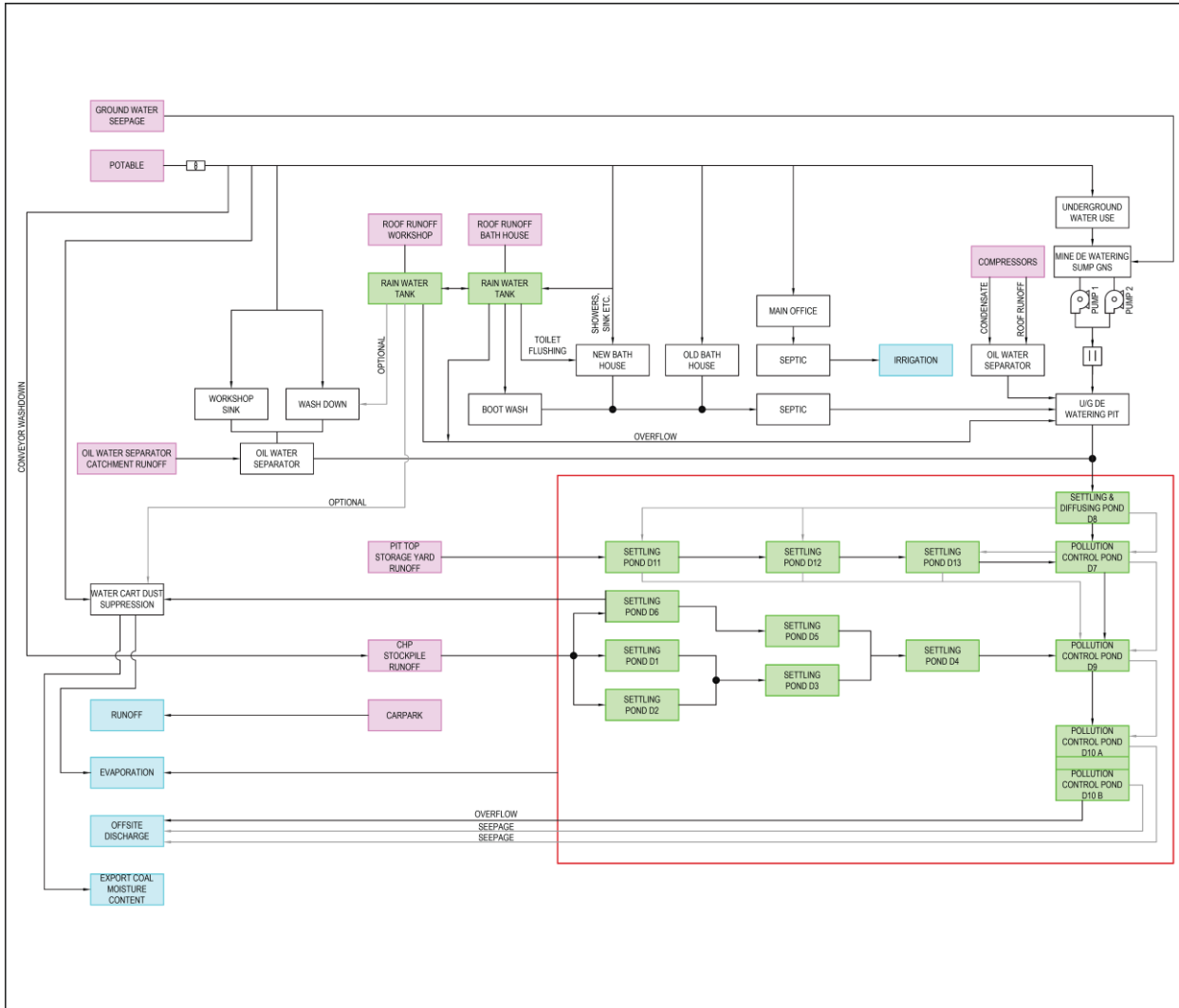

Figure 2: GoldSim schematic water flow diagram

### 3.2.2 Evaporation

Evaporation data was obtained from the Peats Ridge weather station on Waratah Road (station number 61351), approximately 33km south-west of the site. This was the closest meteorological weather station to the CVC with over 25 years of evaporation information. Evaporation data from this weather station was adjusted for the change in site conditions from the measuring site to the sedimentation dams by multiplying the average monthly rates by a pan coefficient of 0.7.

Evaporation from the pollution control dams was calculated using a daily step within the GoldSim model similar to the runoff model calculations. This model used the evaporation rate, modified by the pan coefficient, and the surface area of the dams, which was calculated using survey data.

### 3.2.3 Underground Water Extraction

The Groundwater Assessment (Geoterra, 2013) predicted that the average daily water volumes pumped from the coal face would increase from approximately 7.3 ML/day to 10.5 ML/day. This estimated pumping rate is an average value and therefore pumped flow rates may exceed this value on occasions. It should be noted however, that this average

Review Date	Next Review Date	Revision No	Document Owner	Page
16/01/2024	16/01/2027	7	Environmental Compliance and Approvals Coordinator	Page 11 of 75

daily volume was calculated as an ‘end of mining’ estimate and can be considered a ‘worst case’ prediction of groundwater inflow rates. It is not expected to occur for the majority of the project life.

A groundwater impact assessment was completed in 2022 by GHD (GHD, 2022). The assessment predicted that peak groundwater inflow, in a life of mine scenario extending to 2029, was 7.6 ML/day, increasing from the daily average between January 2020 and April 2022 of 6.7 ML/day. The peak inflow under approved conditions was 2,774 ML/year, which was well within the 4,443 ML/year Water Access Licence 41508 limit.

Pump rate information indicates that the two existing underground dewatering pumps from the Great Northern Seam sump have a maximum pumping rate of 75 L/sec and 75 L/sec respectively. This equates to a total maximum pumping rate from underground of approximately 12.96 ML/day.

However, within the EIS (EMM, 2013) Chain Valley Colliery committed to limiting the main underground pumps to a maximum pump out rate of 10.5 ML/day (equivalent to the predicted average daily volume that will need to be pumped from the coal face during the later stages of the project). This limit remains in place, using the site Citect system to automatically stop the one of the underground pumps when 9.5 ML has been pumped and stopping the second pump if a total of 10.5 ML in any day has been pumped. The pumps are only able to be restarted the following day. This limit can however be temporarily disabled by authorised persons in the event of unacceptable risk (e.g. flooding and risk to employee health and safety), which was a requirement of the site risk assessment completed.

When not pumping, water accumulates underground in a number of storages that exist within both the Great Northern and Wallarah Seams, these are discussed in **Section 4.3**.

### 3.2.4 Pollution Control Dam Characteristics

Information pertaining to the GoldSim modelling of the sedimentation dams was obtained from survey data. This information is shown in **Table 3**. It should be noted that the volume of dam D6 was not available and was estimated based on a 1 m depth, the measured surface area and standard stage/storage relationships. Dams D1 to D6 and D7 to D13 were each modelled as single storages to simplify the water balance processes at the site.

**Table 3: Pollution Control Dam Capacities (as modelled in GoldSim)**

Dam	Volume (m <sup>3</sup> )
D1	80
D2	51
D3	284
D4	547
D5	770
D6	568
<b>Total dams D1 to D6</b>	<b>2300</b>
D7	3856
D8	2933
D9	3796
D10	4802

Review Date	Next Review Date	Revision No	Document Owner	Page
16/01/2024	16/01/2027	7	Environmental Compliance and Approvals Coordinator	Page 12 of 75



TITLE Water Management Plan  
DOC ID ENV 00002 – Water Management Plan  
SITE Chain Valley Colliery

D11	297
D12	229
D13	168
<b>Total dams D7 to D13</b>	<b>16081</b>

Review Date	Next Review Date	Revision No	Document Owner	Page
16/01/2024	16/01/2027	7	Environmental Compliance and Approvals Coordinator	Page 13 of 75

**DOCUMENT UNCONTROLLED WHEN PRINTED**

### 3.2.5 Loss of Water through Coal Export

During mining and conveying, the moisture content in the coal increases due to the use of water sprays at the coal face and at transfer points along the conveyor system. A review of the CVC coal analysis data indicates that the inherent (air dried) moisture content of the coal from underground is approximately 2.7%.

This same data indicates that the total moisture of the CVC coal that is exported is approximately 7.3%, which means that around 4.6% of this total moisture content is added to the coal prior to export. This equates to 69,000 tonnes of additional water at the current proposed rate of production of 1.5 Mtpa. Therefore, approximately 69.0 ML of water is exported from the CVC every year, or 188.9 kL/day.

### 3.2.6 Additional Data

A limited amount of water usage and flow monitoring data at CVC was available for the water balance investigation. However, where historic information was lacking, data and operational information was made available to best derive estimates of the respective water balance parameters (flow rates, water usage, etc.). Additional data, as used in the water balance model, is shown in **Table 4**, as well as comments/assumptions on how this data was derived.

**Table 4: CVC Supplied and Derived Data**

Parameter	Value	Comments/Assumptions
Potable Water: Underground (includes increase of 25% to account for any additional underground potable water demand)	140 ML/yr	Average of underground potable water from monitored water use with an additional 25% to account for increased potable water used underground.
Potable Water: Main Office	211 L/day	Includes shower, sink and toilet facilities.  Shower (26 L/day): Assumes 9 L/min, 10 min/person, 2 showers per week.  Toilet (154 L/day): Assumes 15 employees, employees at work 5 days/week, 6 L/toilet flush, average employee flushes 3 times/day (at work).  Sink (31 L/day): Assumes 15 employees, 1.2 L/wash, employees at work 5 days/week, employees use sink 3 times/day.
Potable Water: Workshop	3724 L/day	Includes equipment washdown and sink use.  Equipment Washdown (3712 L/day): Assumes 1-hour wash/day, 1.031 L/sec flow rate.  Sink (12 L/day): Assumes 1.2 L/wash, 1 sink used 10 times per day.
Potable Water: Bath House 1	24 L/day	Includes sinks facilities.  Sinks (24 L/day): Assumes 1.2 L/wash, 2 sinks each used 10 times per day.
Potable Water: Bath House 2 (Showers, Sink)	8519 L/day	Includes shower and sink facilities  Shower (8190 L/day): Assumes 9L/min, 10 min/person, average of 91 shift ends / day

Review Date	Next Review Date	Revision No	Document Owner	Page
16/01/2024	16/01/2027	7	Environmental Compliance and Approvals Coordinator	Page 14 of 75

		(calculated from shift information provided by DC). Sink (329 L/day): Assumes 220 employees, 1.2 L/wash, employees at work 4 days/week, employees use sink 3 times/day.
Bath House 2 Toilet Flushing Demand	1097 L/day	Assumes 220 employees, employees at work 4 days/week, 4 L/toilet flush (reduced for urinals), average employee flushes 3 times/day (at work).
Potable Water: Bath House 3 (Showers, Sink)	8519 L/day	Includes shower and sink facilities Shower (8190 L/day): Assumes 9L/min, 10 min/person, average of 91 shift ends / day (calculated from shift information provided by DC). Sink (329 L/day): Assumes 220 employees, 1.2 L/wash, employees at work 4 days/week, employees use sink 3 times/day.
Bath House 3 Toilet Flushing Demand	1097 L/day	Assumes 220 employees, employees at work 4 days/week, 4 L/toilet flush (reduced for urinals), average employee flushes 3 times/day (at work).
Bootwash Water Demand	480 L/day	Assumes it is used 3 L/person/shift, average of 91 shift ends / day (calculated from shift information provided by DC).
Dust Suppression Demand	2-3 ML/yr	Calculated from available water cart records
Combined Rainwater Tank Capacity	30 kL	Estimated rainwater tank capacity.

### 3.3 Water Balance Results

#### 3.3.1 Expected Discharge from Chain Valley Colliery

As noted in **Section 3.2.3**, DC limits the main underground pumps to a maximum pump out rate of 10.5 ML/day. As such, the GoldSim model was run (using a deterministic simulation) assuming that the pumps from the Great Northern Seam sump were constantly pumping at this 10.5 ML/day rate. This scenario assumes that adequate capacity is available in the underground workings to effectively store water during periods when the groundwater inflow rate exceeds the underground dewatering rate. This is further discussed in **Section 4.3**. It should be noted that assuming a constant underground pump rate of 10.5 ML/day is a 'worst case' scenario and is only predicted to occur, on occasions, near the end of the project life.

Key statistics from the GoldSim modelling, assuming a constant discharge from underground of 10.5 ML/day, include:

- daily average discharge through EPA Point 1 of 10.716 ML/day;
- maximum discharge through EPA Point 1 of 35.124 ML/day; and

Review Date	Next Review Date	Revision No	Document Owner	Page
16/01/2024	16/01/2027	7	Environmental Compliance and Approvals Coordinator	Page 15 of 75



TITLE	Water Management Plan
DOC ID	ENV 00002 – Water Management Plan
SITE	Chain Valley Colliery

- likelihood of EPA Point 1 volumetric limit exceedance on any given day of 4% (or approximately 15 times per year).

Further to modelled results actual surface water discharge averaged 6,234 kL per day in the 2023 calendar year.

### 3.3.2 Potable Water Use

The total amount of potable water used at the CVC was investigated in the GoldSim model, with and without the committed water savings measures (as described in **Sections 4.7**) in order to quantify how much potable water these measures are likely to save at the site. GoldSim modelling estimates that the potable water used in the pit top area will be reduced from 55.9 kL/day to 23.7 kL/day with an overall saving of 32.3 kL/day (11.8 ML/year) as a result of water saving measures being implemented.

This equates to an approximate reduction in total potable water of 8.9% (for current levels of potable water use) and 7.4% (allowing for a 25% increase in the underground potable water use as a result of the proposed future mining works).

### 3.4 Water Supply and Security

All water required for operational activity has historically been sourced from the single potable water supply connection from the Central Coast Council town-water system. This connection is considered a secure source of water as it is only a small portion of the total water consumed annually by the Central Coast and no viable alternative sources have been identified. Further discussion on water savings and alternative water supply is contained in **Section 4.7**.

No water is obtained from unregulated water sources listed in the *Water Sharing Plan for the Central Coast Unregulated Water Sources 2009*.

Review Date	Next Review Date	Revision No	Document Owner	Page
16/01/2024	16/01/2027	7	Environmental Compliance and Approvals Coordinator	Page 16 of 75

DOCUMENT UNCONTROLLED WHEN PRINTED

## 4 Surface Water Management

### 4.1 Overview of Water Management System

The water management at the CVC pit top is primarily focused on erosion and sediment control, however there are a number of water management components including the underground de-watering, oil water separator system, effluent management and the operation of the pollution control dams.

All water required for operational activity is sourced from the single potable water supply connection from the Central Coast Council town-water system. All excess water from the underground workings is pumped to the Great Northern Seam sump. This water is then pumped to the surface and discharged into the site's pollution control dams.

A combination of surface slope and earth diversion drains on the eastern and northern boundaries results in the majority of the site draining east towards the pollution control dams. A small catchment (i.e. carpark and access road) discharges off-site to the west and north. Other than the carpark catchment, the site's pollution control dams receive all rainfall runoff from the pit top and underground mine water, as well as workshop and wash down water after treatment by an oil separator. A system of 13 pollution control dams have been constructed from a mixture of earth, crushed rock, recycled brick and stone. The dams are interconnected through a series of overflow pipes and spillways which allows water to circulate through each dam before reaching the site discharge point. The dams provide improvement to the site wastewater and runoff quality prior to discharge to Lake Macquarie (via Swindles Creek).

### 4.2 Potable water

All water used for underground mining purposes by CVC is potable water and used in equipment, for cleaning, and dust control. To quantify the estimated volume of water consumed underground a flow/volume meter is installed on the underground water line.

Water is made available throughout the underground workings to satisfy statutory obligations for the production of underground coal. Water is consumed mainly by the following processes.

- when cutting coal at the coal face - to reduce respirable dust and propensity for frictional ignition of coal dust and methane gas;
- when transferring coal along the underground conveyor system and at transfer points - to reduce dust make;
- for use in cleaning;
- for use in equipment; and
- for emergency firefighting purposes.

Water used in the pit top operations is consumed by amenities, dust suppression and wash down.

### 4.3 Underground Water

In addition to the potable water, naturally saline groundwater migrates into the underground workings of the mine. This water is pumped to or collects in a sump within the Great Northern Seam, from there it is pumped to the pollution control dams on the surface. This water is not used for operational purposes due to its high salinity and subsequent potential effects on mine machinery and equipment.

As mentioned in **Section 3.2.3**, DC has limited the main underground pumps to a maximum pump out rate of 10.5 ML/day. To facilitate restrictions to pumping rates, underground water can be stored within both the Great Northern and Wallarah Seams. The underground storage volumes have been assessed and estimated at the following capacities:

- Great Northern Seam – North East Sump, ~ 100 ML;
- Great Northern Seam - Shaft Headings Sump, ~ 200 ML;
- Great Northern Seam - Sump Headings, ~ 5 ML; and

Review Date	Next Review Date	Revision No	Document Owner	Page
16/01/2024	16/01/2027	7	Environmental Compliance and Approvals Coordinator	Page 17 of 75

- Wallarah Seam – Wallarah Sump/Storage Location, 150 to 200 ML.

Details on groundwater management are contained in the Groundwater Management Plan (GwMP) (GeoTerra, 2019) which is in **Appendix 1**.

#### 4.4 Surface Water Catchments and Controls

For the purpose of the WMP runoff from the pit top area is managed as 4 catchment areas including:

- Catchment 1 (Carpark) – carpark, office building and partial runoff from the workshop roof;
- Catchment 2 (Storage Yard) – rear storage yard and oil water separator;
- Catchment 3 (Stockpile) – stockpile, entry road and bathhouse form the third catchment; and
- Catchment 4 (Sedimentation Dams) – pollution control dams.

The above catchments and the major drainage structures are shown on **Figure 3**.

Delta Coal has developed a Trigger Action Response Plan (TARP) for the management of underground and surface water at Chain Valley Colliery, the TARP has been included in **Appendix 9**.

Review Date	Next Review Date	Revision No	Document Owner	Page
16/01/2024	16/01/2027	7	Environmental Compliance and Approvals Coordinator	Page 18 of 75
<b>DOCUMENT UNCONTROLLED WHEN PRINTED</b>				

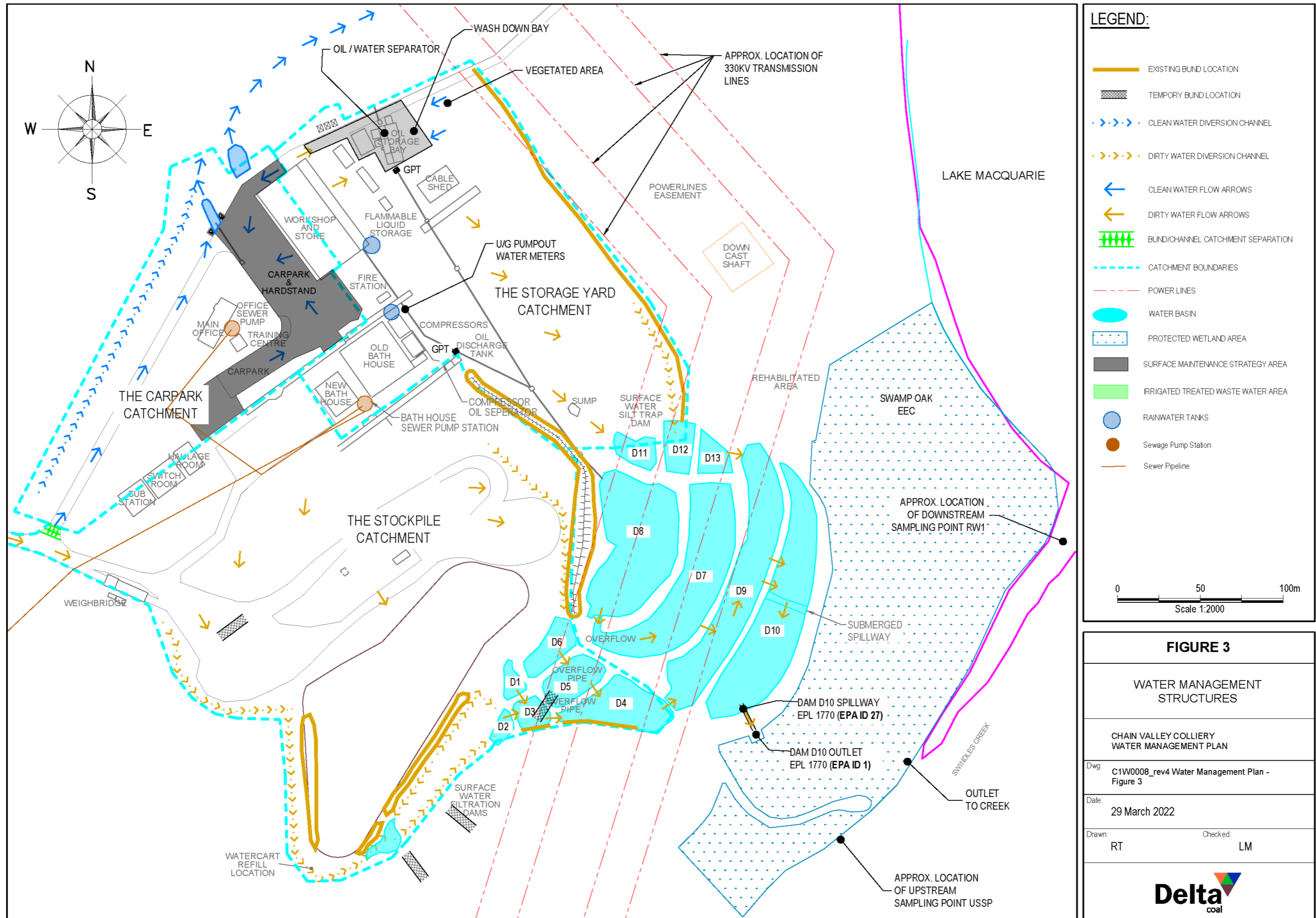

**LEGEND:**

- EXISTING BUND LOCATION
- TEMPORARY BUND LOCATION
- CLEAN WATER DIVERSION CHANNEL
- DIRTY WATER DIVERSION CHANNEL
- CLEAN WATER FLOW ARROWS
- DIRTY WATER FLOW ARROWS
- BUND/CHANNEL CATCHMENT SEPARATION
- CATCHMENT BOUNDARIES
- POWER LINES
- WATER BASIN
- PROTECTED WETLAND AREA
- SURFACE MAINTENANCE STRATEGY AREA
- IRRIGATED TREATED WASTE WATER AREA
- RAINWATER TANKS
- Sewage Pump Station
- Sewer Pipeline

0 50 100m  
Scale 1:2000

**FIGURE 3**

**WATER MANAGEMENT STRUCTURES**

CHAIN VALLEY COLLIERY  
WATER MANAGEMENT PLAN

Dwg: C1W0008\_rev4 Water Management Plan - Figure 3

Date: 29 March 2022

Drawn: RT Checked: LM

**Figure 3: Water Management Structures**

Review Date	Next Review Date	Revision No	Document Owner	Page
16/01/2024	16/01/2027	7	Environmental Compliance and Approvals Coordinator	Page 19 of 75

DOCUMENT UNCONTROLLED WHEN PRINTED

#### 4.4.1 Catchment 1

Catchment 1 (carpark catchment) is a relatively clean catchment as a large portion of this area is vegetated, and there are areas of offices and sealed roads. However, the carpark is unsealed (gravel hardstand) and some sediments accumulate on the surface.

The key control methods implemented in Catchment 1 include:

- clean water diversion channel runs down the north-western perimeter of the pit top to divert any off-site run-on into the natural drainage channel. This is the only major clean water diversion channel required on-site with the remaining topography such that small bunds are sufficient to prevent overland flows entering the site;
- a concrete spoon drain at the intersection with the main site entry road directs dirty runoff from the entry road toward the weighbridge within the storage yard catchment and prevents it from entering this catchment;
- regular sweeping (utilising a street sweeper) of the sealed surface entry road sloping into the carpark to remove accumulated sediment;
- kerb and guttering on the access road provides the perimeter drainage directing runoff to the sediment treatment basins within this catchment; and
- utilisation of two small basins, the first is in line with main drainage outlet of the carpark and the second is beside the workshop adjacent to the carpark. Both basins allow coarse sediment to be removed prior to discharge into the natural drainage channel and are shown on **Figure 3**.

#### 4.4.2 Catchment 2

Catchment 2 (storage yard catchment) includes the main storage yard, the majority of which is gravelled hardstand for equipment storage. This area also includes the vehicle wash down bay and bunded areas which drain to the oil water separator within this catchment.

The key control methods implemented in Catchment 2 include:

- there is no off-site water flowing into this catchment and subsequently clean water diversion is not required;
- an earth bund is installed along the eastern perimeter of the catchment which contains all dirty water runoff; and
- a large portion of this storage yard area drains south-east via overland flow into the pollution control dams D11, D12 and D13 which function as primary settling dams before discharging into the main mine water treatment system (i.e. dams D7 to D10);
- the remainder of the catchment (e.g. stormwater drains, workshop and treated water) enters various inlet pits and drains south-east via the pit and pipe network into the main mine water treatment system via dams D8; and
- an oil water separator to treat runoff from the bunded hydrocarbon storage areas and vehicle wash down bay (see **Section 4.10**).

Review Date	Next Review Date	Revision No	Document Owner	Page
16/01/2024	16/01/2027	7	Environmental Compliance and Approvals Coordinator	Page 20 of 75

#### 4.4.3 Catchment 3

Catchment 3 (stockpile catchment) includes the main entry/haul road, weighbridge (no longer in use), coal handling (including ROM bin) and coal stockpiles (also no longer in use).

The key control methods implemented in Catchment 3 include:

- perimeter bunding along south-west perimeter to prevent clean water entering this area and dirty water leaving the site;
- bunding and surface grading around the water cart fill location to directed runoff to a stockpile catch drain;
- bunding and drainage around the weigh bridge to directed runoff to a stockpile catch drain;
- runoff is contained by two main stockpile catch drains that surround the stockpile. Runoff from this area contains a significant amount of coal fines and there are in-line sumps within the catch drains to trap coarse material before it enters the series of pollution control dams below the stockpile; and
- runoff from this catchment area reports to the pollution control dams D1 to D6 which function as primary settling dams before discharging into the main mine water treatment system (i.e. dams D7 to D10).

#### 4.4.4 Catchment 4

This catchment contains all the pollution control dams (i.e. D1 to D13) which receive runoff from the storage yard area, the stockpile area, pumping of water from underground, and rainfall directly into the dams. The dams were constructed at a similar period to the mine commencement. In 2015, works were completed on the dam to formalise the spillway, and develop a gravity fed pipe discharging over coarse rip-rap to slow water flows and prevent erosion. The works completed in 2015 also included keying a 600mm wide trench into the final dam wall (D13) and backfilling with compacted low permeability clay, the dam wall remediation works were aimed at reducing the likelihood of seepage or dam wall failure of the final dam.

Since the discharge point of the final pollution control dam is gravity fed the retention time of the ponds is entirely dependent on flow rates into the catchment.

The management of this catchment is described in **Section 4.5**.

#### 4.5 Management of Pollution Control Dams

Effective management of surface water runoff relies heavily on the use of pollution control dams for the detention of dirty water as well as mine water. All surface water runoff potentially containing sediment, septic treated bathhouse wastewater, treated water from the oil water separator and underground mine water is captured by the site's pollution control dams prior to discharge under EPL 1770. These dams have been constructed with a mixture of earth, crushed rock, crushed recycled brick and stone and are interconnected through a series of overflow pipes and spillways. The dams discharge through the LDP into native vegetation and flow to Swindles Creek prior to draining into Lake Macquarie on the western shoreline of Chain Valley Bay.

Water is directed through the treatment dams from a number of main inlet locations. Runoff from the stockpile area and the storage yard enters the pollution control dams as described above for those catchments. The underground mine water is pumped to a pit adjacent the compressor house and is combined with the septic treated wastewater from the bathhouse, the treated compressor condensate water and some surface runoff.

From this pit the water is piped to D8 for settling and diffusion. Water within D8 enters D7 via a spillway at the southern end of D8. However, due to the imperfect nature of the dam's construction an unknown amount of water diffuses through the dam wall. The water in D7 flows into D9 in a similar manner, in D9 the underground water is combined with the runoff from other areas on site. The primary spill from D9 to D10 is at the northern end of D9. Once in D10 the water flows over a shallow buffer spillway to the main discharge spillway and offsite at the LDP. A real time monitoring system on the final spillway was installed in February 2015, with monitoring data sent every 30 minutes via 3G to an online database where data can then be viewed or downloaded.

Review Date	Next Review Date	Revision No	Document Owner	Page
16/01/2024	16/01/2027	7	Environmental Compliance and Approvals Coordinator	Page 21 of 75

The dams provide improvement to the site wastewater and runoff quality through the settlement of fines and suspended solids and prevention of off-site discharge of hydrocarbon spills prior to discharge to Lake Macquarie. Based on the volume of the dams and the average daily discharge, the estimated residence time of the water in the pollution control dams is 1 – 2 days. The storage capacity of these dams is provided in **Section 3.2.4**.

#### 4.6 Erosion and Sediment Control / Ground Disturbance

Erosion and sediment control are predominately managed through the implementation of the primary controls described above within the surface water management systems. In addition to these controls, temporary erosion and sediment controls are implemented for any construction disturbance that is not contained with the surface water management system. The primary objective is to ensure that appropriate procedures and programs of work are in place to meet the requirements of Managing Urban Stormwater: Soils and Construction (the Blue Book), Volume 1 and Volume 2E – Mines and Quarries (Landcom, 2004 and Department of Environment and Climate Change (DECC), 2008).

##### 4.6.1 Soils

CVC surface facilities are situated at the southern end of Lake Macquarie. This area is principally comprised of the Doyalson soil landscape with small parts on the Wyong soil landscape. The Doyalson soil landscape is characterised by gently undulating rises on Munmorah Conglomerate with broad crests, ridges and long gently inclined slopes.

Local relief is up to 30 metres and slope gradient is less than 10%. Doyalson soils are strongly acidic soils of low fertility with slight to high erodibility. The Wyong soil landscape is characterised by broad, poorly drained deltaic floodplains and alluvial flats of Quaternary sediments. Local relief is less than 10 metres and slope gradient is less than 3%. Wyong soils are strongly acidic, poorly drained, impermeable soils of very low fertility with saline subsoils.

There is also the potential for acid sulfate soils (ASS) to be present, with probability of occurrence increasing with proximity to the shoreline of Lake Macquarie (see **Section 4.8**).

##### 4.6.2 Potential Impacts

As there is expected to be very little disturbance to ground surfaces and generally restricted to limited construction activities associated with the mines pit top, erosion impacts will be minimal. Construction activities would typically be in areas of relatively flat land at the pit top, with mitigation measures to be put in place to control mobilisation of disturbed soils at the time of, and immediately following, the construction activity.

The greatest potential for soil exposure and movement of soil would occur during any construction activities within areas outside of the pit top water management system (such as at the ventilation shaft site). Exposed soil may be mobilised, leading to erosion, fugitive dust emissions and potential sedimentation of Lake Macquarie. The following sections provide control measures to prevent adverse impacts on surrounding catchment areas and receiving waters.

##### 4.6.3 Standard Erosion and Sediment Controls

Erosion and sediment controls are to be implemented across the CVC for all phases of the operation including construction, operation and maintenance activities to mitigate impacts on watercourses and the surrounding environment. Where activities are contained with the pit top surface water management system, erosion and sediment control will be achieved through the controls described in the previous section.

Where soil disturbance activities are outside of these controls, standard erosion and sediment control techniques and management principles are used in accordance with the requirements of Managing Urban Stormwater: Soils and Construction Vol. 1 and Vol. 2E - Mines and Quarries (referred to as the Blue Book in this Plan) (Landcom, 2004 and DECC, 2008).

For activities at CVC, a 'Permit to Clear or Disturb Land' is required prior to disturbance. This permit includes requirements to have water management and erosion controls in place prior to disturbance.

##### 4.6.4 Construction Erosion Management Plan

Where soil disturbance activities are outside of the surface water management system, erosion and sedimentation shall be effectively controlled through the development of a Construction Erosion Management Plan (CEMP) prior to undertaking large scale disturbances (i.e. greater than 2,500 m<sup>2</sup>). The CEMP shall be consistent with the Blue Book (Landcom, 2004 and DECC, 2008) and would include the following key principles:

Review Date	Next Review Date	Revision No	Document Owner	Page
16/01/2024	16/01/2027	7	Environmental Compliance and Approvals Coordinator	Page 22 of 75

- conducting best practice land clearing procedures for all proposed disturbance areas including:
  - coordinating construction activities to minimise exposure of disturbed soils to the elements; and
  - topsoil stripping procedures to reduce deterioration in topsoil quality and dust generation.
- appropriate storage of topsoil stockpiles in areas away from roadways and other drainage lines;
- appropriate design of access tracks;
- use of diversion structures to separate ‘clean’ water runoff from disturbed areas runoff, to minimise volumes of sediment-laden and mine water for management;
- ensuring sediment-laden runoff is treated via designated sediment control devices;
- topsoiling, reshaping and revegetation of disturbed areas as soon as possible following the completion of construction activities;
- temporary erosion and sediment controls to be in place prior to any construction activity outside of an existing dirty water management system; and
- implementing an effective maintenance program for the site.

The above principles are addressed in further detail in **Appendix 4**.

#### 4.7 Water Savings

CVC seeks continual improvement in relation to water consumption, potential improvements in water efficiency, alternative water sources and options for recycling and reuse. The following measures are implemented on site:

- use of a road sweeper to clean roads (as opposed to more frequent washing of roads with a water cart);
- rainwater tank installed on the workshop;
- repair works to aging pipelines to reduce losses from leakage; and
- trial use of chemical dust suppressant to reduce water cart usage.

The primary use of potable water is to supply underground activities. The water storage within the dirty water dams is not suitable for supply to underground machinery.

#### 4.8 Acid Sulfate Soils

ASS are naturally occurring coastal and near-coastal sediments and soils containing iron sulfides formed under anoxic conditions, where the sulfides are disturbed, oxidation occurs and a leachate of pure sulfuric acid is produced, causing significant environmental impacts particularly if drained to waterways. ASS are considered likely to be present in soil horizons less than 5 m AHD and coastal wetlands / swampy regions.

A review of the NSW SEED *Acid Sulfate Soils Risk* maps identifies that the CVC pit top facilities and immediate surrounds have a low probability / no known occurrence of ASS within underlying soils, however the Swamp Oak Floodplain EEC located adjacent the CVC pollution control dams extending up the Swindles Creek tributary and along the foreshore of Lake Macquarie are identified as having a high probability for the occurrence of ASS. The ASS maps reviewed of the CVC pit top locality have been provided in **Appendix 5**.

Where ASS are left undisturbed and in anoxic conditions there is minimal environmental risk. Avoiding disturbance of potential ASS is the preferred management method, however where unavoidable, any proposed disturbance (including potential dewatering) to potential acid sulfate soils will require an ASS assessment to be completed prior. The assessment is to be undertaken in accordance with the NSW Acid Sulfate Soils Management Advisory Committee (ASSMAC), *Acid Sulfate Soils Manual 1998* (ASSMAC 1998) – *Assessment Guidelines* to confirm the presence of actual and/or potential ASS.

Review Date	Next Review Date	Revision No	Document Owner	Page
16/01/2024	16/01/2027	7	Environmental Compliance and Approvals Coordinator	Page 23 of 75

Should disturbance to identified ASS be required, a project specific ASS Management Plan (ASSMP) will be prepared in general accordance with ASSMAC 1998 – *Management Plan Guidelines* and at minimum contain:

- An overview of environmental conditions of the site and off-site surrounds;
- An overview of the proposed works and the objectives of the ASSMP;
- Define the extent of acid sulfate soils with a review of environmental assessments undertaken relative to the proposed works;
- A review of potential management methods and selection of the most appropriate method for minimising environmental impact associated to the proposed works;
- A program for validating any material produced and treated as a part of completing the works;
- A description of the roles and responsibilities for the implementation of the ASSMP; and
- A description of the contingency measures to be implemented to deal with unexpected events or in the event that of failure of management procedures.

If an ASSMP is required, a development application would also need to be approved for the works by the respective local government authority (LGA), which at CVC is Central Coast Council.

For activities at Delta Coal, Permit 'PER 00022 – Excavation, Stake or Pile Driving' is required to be approved by the sites Environmental Coordinator prior to any soil disturbance which includes requirements to review ASS maps and identify potential ASS prior to the commencement of works potential disturbing ASS.

#### 4.9 Sewerage Disposal and Management

There are two sources of domestic wastewater located at the pit top facilities. The first source is generated in the administration office building and the second is generated in the operations bathhouses and operations area. As of July 2023, both wastewater streams are pumped to the municipal sewer system via an on-site sewage pump station and rising main.

#### 4.10 The Oil Water Separator

Water that is likely to be contaminated with oil and grease, such as runoff from the oil storage facilities, diesel tank storage, workshop / maintenance areas and wash bay is directed to and treated by an oil water separator.

The system includes a packed bed oil separation system where solids are removed in the grit trap and oily water is drawn from the sump through a floating skimmer, into the packed bed oil separator by a non-emulsifying pump. The system has a capacity of 2000 L/hr of through flow. The waste oil is collected in a container and the treated water flows by gravity to the pollution control dams.

A separate oil water separation system is installed on the condensate drain from the compressors on site. This system consists of an in-ground tank where water is passed through and under over a weir arrangement and then discharged to the pollution control dams.

Inspections and maintenance of the separation systems occurs regularly, in addition to water quality monitoring and analysis for total oil and grease at all monitoring points as per **Section 5.3**.

Review Date	Next Review Date	Revision No	Document Owner	Page
16/01/2024	16/01/2027	7	Environmental Compliance and Approvals Coordinator	Page 24 of 75

## 5 Monitoring

To ensure the continued functionality of the surface water management system and to assist CVC identify any potential issues with the system, an on-going water monitoring program is implemented, inclusive of water quality and stream health monitoring.

### 5.1 Baseline Surface Water Quality Monitoring Data

CVC collates and maintains an up to date database of surface water quality monitoring data for all sampling at the mine.

A baseline water quality assessment is presented in GSS Environmental, March 2013, Chain Valley Mining Extension 1 Project Surface Water Assessment. (GSSE 2013) included as **Appendix 6** (Section 3.52 and Appendix A in particular). However, the GSSE 2013 report noted limited available historic data to determine appropriate baseline concentrations for heavy metals due to a change in testing method to include dissolved and total metals in August 2010.

The below summary baseline takes the average concentration of discharged waters between August 2010 and July 2015 being the last month of routine heavy metals monitoring following variations to EPL 1770, with values adopted from historical Annual Environmental Management Reports (AEMR). For the purpose of developing a baseline value of discharged surface water quality, where the value of the pollutant tested was less than the laboratory limit of reporting (LOR) for the testing method, the LOR value was adopted. LDP1 monitoring data utilised to determine the baseline concentration in Table 5 has been provided as **Appendix 8**.

**Table 5 - Summary baseline, surface water quality**

Tested Pollutant	LDP1 Average Value August 2010 to July 2015 (mg/L - unless specified)	Receiving Environment Chain Valley Bay (GSSE 2013) (mg/L)	Receiving Environment Marks Point (GSSE 2013) (mg/L)	ANZECC 2000 / ANZG 2018 DGV's, 95% marine environment (mg/L)
pH	7.78 pH Units	-	-	Between 7 and 8.5 pH units
Total Suspended Solids	9.7	-	-	-
Conductivity	30,425 µs/cm	-	-	-
Total Oil and Grease	5	-	-	-
Faecal Coliforms	32.5 CFU/100ml	-	-	<150 CFU/100ml (primary contact i.e. swimming)  <1000 CFU/100ml (secondary contact i.e. boating and fishing)  NHRMC – guidelines for managing risks in recreational water, 2008.

Review Date	Next Review Date	Revision No	Document Owner	Page
16/01/2024	16/01/2027	7	Environmental Compliance and Approvals Coordinator	Page 25 of 75

Tested Pollutant	LDP1 Average Value August 2010 to July 2015 (mg/L - unless specified)	Receiving Environment Chain Valley Bay (GSSE 2013) (mg/L)	Receiving Environment Marks Point (GSSE 2013) (mg/L)	ANZECC 2000 / ANZG 2018 DGV's, 95% marine environment (mg/L)
Enterococci	97.1 CFU/100ml	-	-	<40 CFU/100ml (primary contact) <200 CFU/100ml (secondary contact)
Ammonia as N	0.0861	-	-	0.91
Nitrate + Nitrate as N	0.486	-	-	50 (NHRMC -Australian Drinking Water Guidelines, 2011)
Total Kjeldahl Nitrogen as N	0.277	-	-	-
Total Nitrogen as N	0.603	-	-	-
Total Phosphorus	0.0402	0.04	0.08	Algal Low risk = <0.01 Algal Mod risk = 0.01 – 0.025 high risk = 0.025 – 0.1 Algal very high risk = >0.1
Total Phosphorus as P	0.0377	-	-	-
Biochemical Oxygen Demand	2.03	-	-	-
Aluminium (total)	0.1196	0.04	0.12	Insufficient Data (ID)
Aluminium (soluble)	0.0554	<0.01	0.04	ID
Arsenic (total)	0.0023	<0.0005	0.0019	0.0023 (marine low reliability environmental concern level)
Arsenic (soluble)	0.0022	<0.0005	0.002	0.0023 (marine low)

Review Date	Next Review Date	Revision No	Document Owner	Page
16/01/2024	16/01/2027	7	Environmental Compliance and Approvals Coordinator	Page 26 of 75

Tested Pollutant	LDP1 Average Value August 2010 to July 2015 (mg/L - unless specified)	Receiving Environment Chain Valley Bay (GSSE 2013) (mg/L)	Receiving Environment Marks Point (GSSE 2013) (mg/L)	ANZECC 2000 / ANZG 2018 DGV's, 95% marine environment (mg/L)
				reliability environmental concern level)
Beryllium (total)	0.0020	<0.0001	<0.0001	ID
Beryllium (soluble)	0.0019	<0.0001	<0.0001	ID
Cadmium (total)	0.0004	<0.0002	0.0004	0.0007
Cadmium (soluble)	0.0004	<0.0002	0.0004	0.0007
Chromium (total)	0.0033	<0.0005	<0.0005	0.0044
Chromium (soluble)	0.0025	<0.0005	<0.0005	0.0044
Cobalt (total)	0.0016	<0.0002	<0.0002	0.001
Cobalt (soluble)	0.0015	<0.0002	<0.0002	0.001
Copper (total)	0.0051	<0.001	0.004	0.0013
Copper (soluble)	0.0040	<0.001	0.002	0.0013
Lead (total)	0.0030	<0.0002	0.0012	0.0044
Lead (soluble)	0.0028	<0.0002	0.0004	0.0044
Mercury (total)	0.0001	<0.0001	<0.0001	0.0001
Mercury (soluble)	0.0001	<0.0001	<0.0001	0.0001
Molybdenum (total)	0.0051	0.0024	0.012	0.034 (low reliability DGV)
Molybdenum (soluble)	0.0045	0.0025	0.0116	0.034 (low reliability DGV)
Nickel (total)	0.0042	0.0008	0.0007	0.007
Nickel (soluble)	0.0041	<0.0005	<0.0005	0.007
Selenium (total)	0.0212	<0.002	<0.002	0.003 (low reliability DGV)

Review Date	Next Review Date	Revision No	Document Owner	Page
16/01/2024	16/01/2027	7	Environmental Compliance and Approvals Coordinator	Page 27 of 75

Tested Pollutant	LDP1 Average Value August 2010 to July 2015 (mg/L - unless specified)	Receiving Environment Chain Valley Bay (GSSE 2013) (mg/L)	Receiving Environment Marks Point (GSSE 2013) (mg/L)	ANZECC 2000 / ANZG 2018 DGV's, 95% marine environment (mg/L)
Selenium (soluble)	0.0190	<0.002	<0.002	0.003 (low reliability DGV)
Silver (total)	0.0025	<0.0001	0.0004	0.0014
Silver (soluble)	0.0024	<0.0001	0.0004	0.0014
Vanadium (total)	0.0208	<0.0005	0.0016	0.1
Vanadium (soluble)	0.0191	<0.0005	0.0016	0.1
Zinc (total)	0.0404	0.015	0.019	0.015
Zinc (soluble)	0.0336	0.008	0.018	0.015
Anionic Surfactants as MBAS	0.1702	-	-	-

Review Date	Next Review Date	Revision No	Document Owner	Page
16/01/2024	16/01/2027	7	Environmental Compliance and Approvals Coordinator	Page 28 of 75

## 5.2 Impact Assessment Criteria and Trigger Levels

### 5.2.1 Surface Waters

Table 6 provides water quality parameters and relevant limits to be measured at the LDP as per EPL 1770.

**Table 6: Water Quality Monitoring Limits for Chain Valley Colliery**

Parameter	Trigger Value	Source
Faecal coliform	200 colony forming units per 100 millilitres	EPL 1770 note: following a variation to EPL 1770 after completion of PRP 8 and PRP 9 in October 2023, CVCs limit for faecal coliform will be reviewed in 6 months (i.e. April 2024).
pH	6.5-8.5	EPL 1770
TSS	50 mg/L	EPL 1770
Oil and Grease	10 mg/L	EPL 1770

### 5.2.2 Underground Water

Groundwater monitoring is described within the GwMP provided in **Appendix 1**.

## 5.3 Surface Water Monitoring and Frequency

DC will continue to monitor as required by the EPL and also undertake monitoring beyond the requirements of the EPL. The monitoring locations, parameters to be monitored and the required frequency are detailed in **Table 7** with the position of these monitoring locations shown on **Figure 2**. Surface water quality monitoring summary plots for LDP1 for the period from January 2012 to December 2023 are presented in **Appendix 7**.

**Table 7: Surface Water Quality Monitoring Locations and Frequency**

Identification	Type of Monitoring Point	Discharge Limits	Parameter	Frequency	Sampling Method
Outlet to Creek (OTC)	Operational (where discharged water enters Swindles creek)	N/A	<ul style="list-style-type: none"> <li>pH</li> <li>Total suspended solids</li> <li>Biochemical Oxygen Demand</li> <li>Faecal Coliforms</li> <li>Enterococci</li> <li>Total oil and grease</li> <li>Electrical Conductivity</li> <li>Total Nitrogen</li> <li>Total Phosphorus</li> </ul>	Monthly (min 4 weeks)	Grab sample
Dam 10 Outlet LDP1 and LDP27	EPL 1770 Licensed Discharge Points 1 (Dam piped discharge) and 27 (Dam spillway)	12,161 kL per day			
USSP	Baseline Data (Swindles Creek Upstream of Site)	N/A			
RW1	Baseline Data (Swindles Creek Downstream of Site)	N/A			

Review Date	Next Review Date	Revision No	Document Owner	Page
16/01/2024	16/01/2027	7	Environmental Compliance and Approvals Coordinator	Page 29 of 75



TITLE Water Management Plan  
DOC ID ENV 00002 – Water Management Plan  
SITE Chain Valley Colliery

Identification	Type of Monitoring Point	Discharge Limits	Parameter	Frequency	Sampling Method
			<ul style="list-style-type: none"><li>Anionic Surfactants</li></ul>		

All monitoring of waters should be undertaken in accordance with Approved Methods for Sampling and Analysis of Water Pollutants in NSW (DECCW, March 2004). Additionally, pollutant concentration measurements shall be determined in micrograms per litre and within ANZG 2018 (formerly ANZECC 2000) concentration limits unless noted otherwise.

Review Date	Next Review Date	Revision No	Document Owner	Page
16/01/2024	16/01/2027	7	Environmental Compliance and Approvals Coordinator	Page 30 of 75

**DOCUMENT UNCONTROLLED WHEN PRINTED**



TITLE	Water Management Plan
DOC ID	ENV 00002 – Water Management Plan
SITE	Chain Valley Colliery

#### 5.4 Stream Health Channel Flow and Riparian Vegetation Monitoring

A program to monitor creek line channel stability and health of riparian vegetation within Swindles Creek is undertaken along a short length of the downstream watercourse. Observations of stream health and stability are undertaken quarterly and recorded on the CVC 'Creek Stability Inspection' form.

Monitoring of Swindles Creek, as per the creek stability form, includes multiple photographic points at representative locations. Photos are taken over multiple inspections in a repeatable manner, with the inspection specifically including:

- general observations of water quantity and quality;
- documenting locations and dimensions of significant erosive or depositional features;
- documenting evidence of erosion and exposed soils;
- noting general indicators of stream health, including abundance of flora and fauna; and
- a review and comparison of results to previous inspections.

Where degradation or adverse erosion is occurring, additional investigations will be undertaken to assess whether the impacts may be associated with the operation of the mine and ameliorative actions undertaken as required. In addition, further riparian vegetation monitoring will be undertaken in accordance with the Biodiversity Management Plan.

#### 5.5 Groundwater Monitoring Program

Details of the groundwater monitoring program is contained in the GwMP in **Appendix 1**, which includes monitoring of mine inflows and private bore water levels.

Review Date	Next Review Date	Revision No	Document Owner	Page
16/01/2024	16/01/2027	7	Environmental Compliance and Approvals Coordinator	Page 31 of 75

DOCUMENT UNCONTROLLED WHEN PRINTED

5.6

**5.6 Additional Operational Monitoring**

In addition to the other monitoring described above, DC also undertakes periodic surface water quality monitoring for dams within the site. This additional monitoring allows the performance of the surface water management system to be assessed for various areas around the site. CVC is also committed to monitoring water usage onsite. Water usage is currently monitored through the following:

- metering of the potable supply to site;
- monitoring of the volume of water pumped from the Great Northern Seam sump to the surface and
- maintaining records of the water cart operation, including fill times.

**5.7 Inspections and Maintenance**

All water management structures will be inspected regularly. **Table 8** contains the inspection and maintenance schedule used to ensure the water management structures are functioning effectively throughout CVC. The inspections will also determine the scheduling of maintenance required for the structures.

**Table 8: Inspection Schedule for Water Management Structures**

To Be Inspected	Inspection Frequency	Routine Maintenance	Maintenance Frequency
Sediment dams	Monthly	Desilting of dams	Annual however can be amended based on inspection and water quality results.
Drainage channels and associated in-line sumps	Monthly	Remedial works for erosion and clearing of debris	Undertaken as required when erosion or debris is noted within monthly inspections
Works in progress (including temporary erosion and sediment control structures)	Weekly	Repairs and additional controls implemented where structures are damaged or not performing adequately.	As required.
Roads and hardstand areas	Monthly	Roads and hardstand areas are kept clear of debris by sweeping of sealed roads utilising a vacuum street sweeper and unsealed hardstand areas are inspected daily by the control room operator with a watercart available 24/7 to delta coal for dust suppression.	6 monthly street sweeping or as required.  Watercart shifts are scheduled daily depending on the need for dust suppression based on weather forecasts and visual moisture status of unsealed areas however is available as/when required.
Oil water separator unit	Weekly mechanical inspection Monthly environmental inspection	Maintenance by a service contractor.  Collection of separated oil collection.	6 monthly unit servicing or as required where fault is found during inspection.  Separated oil is collected when storage approaches 50% capacity, as determined during weekly inspections.

Review Date	Next Review Date	Revision No	Document Owner	Page
16/01/2024	16/01/2027	7	Environmental Compliance and Approvals Coordinator	Page 32 of 75

To Be Inspected	Inspection Frequency	Routine Maintenance	Maintenance Frequency
Oil water separator sump	Monthly	Desilting of the washdown bay sump and cleaning of oil water separator sump.	6 monthly basis minimum or as required from inspections.
Air compressor oily water separator	Monthly	Removal of separated oily water via a vacuum truck as required from monthly inspections	as required determined from monthly inspections
Carpark	Monthly	Re-grading and compaction of carpark to ensure a smooth surface is maintained to prevent erosion	6 monthly or as required.

In addition to these inspections, regular water quality monitoring is undertaken as described above. The results of this monitoring with regards to total suspended solids will assist in assessing the effectiveness of the water management system, along with highlighting any possible areas that need to have additional controls added or improve the function of existing controls.

All water management structures will be maintained in a functioning condition. Where controls are observed to be not functioning correctly, the controls will be restored to meet the required standard. The maintenance and monitoring of specific features of the site are described in the sections below.

### 5.7.1 Sediment Dams

Visual inspections of the sediment dams are undertaken to determine the clarity of the water and if any maintenance is required. The inspections also enable correct scheduling of de-silting works and prompt repairs and/or replacement of damaged works. When required, the silt from dams is removed and stored so that it is not able to be washed back into the dam. Documented inspections of the above are part of the Monthly Environmental Inspection which is scheduled via a work order (part of the CVC maintenance management system).

As part of the 2022 Independent Environmental Audit of CVC, action 6 required DC to develop and implement a maintenance schedule for desilting on-site dams and drains. The undertaking of desilting of on-site dams and drains will be based on routine inspection to determine the sediment accumulation and requirement for desilting works. Desilting of dams with sediment accumulation will be undertaken on an annual basis.

Dams and drains at CVC are detailed in **Figure 3**. Inspection of drains is undertaken within a monthly environmental inspection issued through the sites work order system to ensure that site drains are clear and operable without sediment accumulation, works are scheduled on the findings of the inspections.

Sediment dams are to be maintained in a condition consistent with the Dams Safety Act 1978.

### 5.7.2 Drainage Channels

For clean water diversions, any signs of erosion along the length of the drains should be noted and remedial works undertaken as required. Where significant erosion is observed, additional erosion controls are constructed e.g. establishment of vegetation cover, use of temporary sediment devices until the vegetation is established, scour protection (rock-armouring or erosion blanket) of the channel surface.

Where dirty water drainage channels contain in-line sumps, these will be cleaned on a regular basis depending on the accumulation of material within the sumps.

### 5.7.3 Temporary ESC Structures

Regular visual checks will be made of any temporary erosion and sediment controls (ESC) such as sediment filter fences, sandbag weirs etc. to ensure that they are functioning adequately. Structures will be repaired where required.

Review Date	Next Review Date	Revision No	Document Owner	Page
16/01/2024	16/01/2027	7	Environmental Compliance and Approvals Coordinator	Page 33 of 75

#### 5.7.4 Roads and Hard Stand Areas

A water cart will be used around the site to ensure dust is kept to a minimum. This will be undertaken on an as needs basis, with more regular use during the warmer months. The use of chemical dust suppressant is also being trialled to reduce water usage. A street sweeper is routinely used to sweep the sealed entrance roads.

#### 5.7.5 Washbay Oil Water Separator

The packed bed oil separator system is designed to minimise maintenance and servicing. As oil separator systems are critical for the reliable prevention of oil contamination, regular inspections/servicing are important. It is critical that the mechanisms be regularly checked for operation to prevent environmental contamination. Preventative maintenance may also prevent failures before they occur by detecting trends in functionality.

This system has specific weekly and monthly work orders that ensure the system is serviced and maintained.

All accumulated waste oils and solid material shall be disposed of periodically by a licensed operator. The weekly waste management inspection will determine waste oil levels and disposal requirements.

#### 5.7.6 Compressor Condensate Oil Water Separator

Excess oil from the compressors and surrounds is contained, piped to a collection tank which is inspected weekly to ensure the system is serviced and maintained.

Any accumulated waste oil is then removed for recycling by licensed and approved waste management contractors.

#### 5.7.7 Carpark

The CVC carpark was previously unsealed, however, the carpark was sealed in September 2022 which included grading, laying of road base, compaction, covering in gravel and spraying with a bitumen sealant.

#### 5.7.8 Underground Flow Monitoring Devices

Water flow monitoring appliances have been installed in the mine to measure pumped water volumes to and from the mine workings. These appliances shall be maintained in good working order, and if required, the mine will supply a test certificate to certify the current accuracy of the appliances furnished by the manufacturer or by some duly qualified person or organisation.

### 5.8 Data Recording and Publication

Recording of monitoring data will be undertaken in accordance with the requirements outlined in EPL 1770. DC will collate and maintain an up-to-date database of surface water quality monitoring data for all sampling at the mine. Monitoring results will be interpreted as they are received in order to ensure water quality is maintained within the desired parameters.

A summary of results, including daily volumetric discharge and water quality results, will be prepared monthly and made publicly available on the DC website ([www.deltacoal.com.au](http://www.deltacoal.com.au)) in accordance with the requirements of *Protection of the Environment Operations Act, 1997*.

The results will also be compared to relevant site operations and meteorological conditions to further interpret the results. This comparison between samples, sampling periods and against other factors will assist in identifying whether the activities on the site are in fact affecting the water quality of the local catchment.

Results of surface water quality monitoring will be reported in the Annual Review. The results will also be made available to the Community Consultative Committee members on a regular basis as part of the Environmental Monitoring and Reporting process, as well as to the Central Coast Council and Lake Macquarie City Council (LMCC).

Review Date	Next Review Date	Revision No	Document Owner	Page
16/01/2024	16/01/2027	7	Environmental Compliance and Approvals Coordinator	Page 34 of 75

## 6 Reporting

### 6.1 Regular Reporting

The water monitoring results will be reviewed on a monthly basis to confirm compliance with the conditions specified in **Section 5** or ensure corrective action is taken where results or trends indicate non-compliance or risk of future non-compliance.

A summary of monthly environmental monitoring results will be published on the DC website.

### 6.2 Annual Review

The water monitoring results will be reviewed on a monthly basis to confirm compliance with the conditions specified in **Section 5** or ensure corrective action is taken where results or trends indicate non-compliance or risk of future non-compliance.

The results will also be included in the Annual Review. The Annual Review will include:

- a summary of monitoring results,
- comparison against the water quality criteria;
- summary of previous years monitoring results;
- comparison against predictions in the Environmental Impact Statement (EIS);
- identify any trends in water quality/quantity;
- identify any non-conformances over the year; and
- describe any actions currently implemented or planned to ensure compliance with the water quality impact criteria.

The Annual Review will be forwarded to the relevant authorities including the DCCEE, EPA and WaterNSW. The Annual Review will also be forwarded to members of the Community Consultative Committee and local Councils (Central Coast and Lake Macquarie) and will also be placed on the CVC website.

The EPA will be provided with an annual return, including monitoring details, as required by EPL 1770.

### 6.3 Incident or Non-Compliance Response and Reporting

Environmental incidents and hazards at CVC and MC are reported in DC's incident reporting and management system. Reported incidents are investigated and corrective and/or preventative actions are identified in accordance with DC's Health and Safety Standard – Incident Reporting.

In addition to internal reporting requirements, if an incident causes or threatens to cause material harm to the environment (e.g. a pollution incident), then consistent with Schedule 6, Condition 6 of SSD-5465, DC must immediately notify the Department and any other relevant agencies (such as the NSW EPA and Resources Regulator) after it becomes aware of such an incident. The incident notification must identify the location and nature of the incident, the development application (name and number) and be in writing to [compliance@planning.nsw.gov.au](mailto:compliance@planning.nsw.gov.au).

In accordance with Schedule 6, Condition 7 of SSD-5465, DC must notify the Department and other relevant agencies within seven days of becoming aware of a non-compliance to the conditions of the consent. The non-compliance notification must identify the development, set out the conditions of the consent that have not been complied with, why the non-compliance occurred and the reasons for the non-compliance (if known) as well as what actions have been, or will be, undertaken to address the non-compliance. The notification must be in writing to [compliance@planning.nsw.gov.au](mailto:compliance@planning.nsw.gov.au).

CVC and MC have PIRMPs in place, which provide details on how to identify, manage, record and investigate environmental incidents and emergencies. Both PIRMPs identify clear roles and responsibilities for actions required in the event of an incident or emergency.

Review Date	Next Review Date	Revision No	Document Owner	Page
16/01/2024	16/01/2027	7	Environmental Compliance and Approvals Coordinator	Page 35 of 75



TITLE	Water Management Plan
DOC ID	ENV 00002 – Water Management Plan
SITE	Chain Valley Colliery

DC categorises environmental issues at CVC and MC as either serious (Category E11), significant (Category E12) or minor (Category E13). Definitions, immediate actions and follow-up actions for each category are summarised in **Appendix 10**.

The GwMP in **Appendix 1** contains the assessment triggers and ameliorative measures relevant to the groundwater monitoring.

Any incidents or complaints will be recorded and fully investigated to find root causes and corrective actions implemented where necessary. Additionally, the following measures will be undertaken:

- a review of management practices to systematically identify and implement options to modify site practices so as to ensure effective water management and erosion and sediment control activities in order to achieve the goals stated in this plan; and
- additional water quality monitoring may be conducted at a complainant’s request at an appropriate frequency.

Review Date	Next Review Date	Revision No	Document Owner	Page
16/01/2024	16/01/2027	7	Environmental Compliance and Approvals Coordinator	Page 36 of 75

**DOCUMENT UNCONTROLLED WHEN PRINTED**

## 7 Stakeholder Management, Response and Training

### 7.1 Complaint Protocol

DC has a 24-hour telephone hotline (1800 115 277) for members of the public to lodge complaints, concerns, or to raise issues associated with the operation. This service aims to promptly and effectively address community concerns and environmental matters. All complaints are recorded and responded to.

The information recorded in the complaint register includes:

- date and time the complaint was lodged;
- personal details provided by the complainant;
- nature of the complaint;
- action taken or if no action was taken, the reason why; and
- follow up contact with the complainant.

### 7.2 Independent Review

As detailed in Condition 2, Schedule 5 of SSD-5465, an Independent Review can be requested by a landowner who “*considers the development to be exceeding the relevant criteria in Schedule 3*”.

If the Secretary is satisfied that an independent review is warranted, then within 2 months of the Secretary’s decision the Applicant shall:

(a) *commission a suitably qualified, experienced and independent person, whose appointment has been approved by the Secretary, to:*

- *consult with the landowner to determine his/her concerns;*
- *conduct monitoring to determine whether the development is complying with the relevant criteria in Schedule 3; and*
- *if the development is not complying with these criteria then identify the measures that could be implemented to ensure compliance with the relevant criteria; and*

(b) *give the Secretary and landowner a copy of the independent review*

### 7.3 Dispute Resolution

Any disputes that are not adequately addressed by the complaints handling process are handled by DC’s Environmental Compliance Coordinator. If the response is still not considered by the complainant to satisfactorily address their concern or the matters raised, a meeting is convened with the Mine Manager and Environmental Compliance Coordinator together with the complainant.

The complainant is advised in writing of the outcomes of the meeting and the actions (where applicable) to be implemented as a result. After implementation of the proposed actions, the complainant is contacted and feedback sought as to their satisfaction or otherwise with the measures taken

If an agreed outcome cannot be determined or the complainant is still not satisfied by the actions undertaken by DC, then an independent review can be requested by the complainant to determine whether further actions should be implemented by DC to resolve the matter.

Condition 2 of Schedule 5 of SSD-5465 (CVC) lists the requirements for an independent review as follows:

Review Date	Next Review Date	Revision No	Document Owner	Page
16/01/2024	16/01/2027	7	Environmental Compliance and Approvals Coordinator	Page 37 of 75

**INDEPENDENT REVIEW**

2. If an owner of privately-owned land considers the development to be exceeding the relevant criteria in Schedule 3, then he/she may ask the **Planning Secretary** in writing for an independent review of the impacts of the development on his/her land.

If the **Planning Secretary** is satisfied that an independent review is warranted, then within 2 months of the **Planning Secretary**'s decision the Applicant **must**:

- (a) commission a suitably qualified, experienced and independent person, whose appointment has been approved by the **Planning Secretary**, to:
  - consult with the landowner to determine his/her concerns;
  - conduct monitoring to determine whether the development is complying with the relevant criteria in Schedule 3; and
  - if the development is not complying with these criteria then identify the measures that could be implemented to ensure compliance with the relevant criteria; and
- (b) give the **Planning Secretary** and landowner a copy of the independent review.

**7.4 Training, Awareness and Competence**

Training is an essential component of the implementation phase of this WMP. The Environmental Compliance and Approvals Coordinator will ensure that training and awareness processes are implemented to manage, identify and minimise potential impacts of CVC and to ensure personnel are aware of their roles and responsibilities in terms of water quality management and erosion and sediment control.

Generally training at CVC consists of induction training for new starters and contractors along with environmental awareness training at two-year intervals and ongoing “toolbox” training for all permanent employees as required. Site inductions also specifically identify that no unauthorised clearing is to occur.

As the document owner, the Environmental Compliance Coordinator is the contact point for any person that does not understand this document or their specific requirements and will provide guidance and training to any person that requires additional training regarding this management plan.

Review Date	Next Review Date	Revision No	Document Owner	Page
16/01/2024	16/01/2027	7	Environmental Compliance and Approvals Coordinator	Page 38 of 75

## 8 Audit and Review

### 8.1 Overview

This document shall be reviewed, and if necessary revised, annually or within 3 months of the following;

- the submission of an Annual Review;
- the submission of an incident report;
- the submission of an independent environmental audit; and
- following any modification to the development consent or EPL.

### 8.2 Audits

Internal and external audits of this document and all other Environmental Management System documents are to be undertaken every three years. Improvements from the audit are to be incorporated in the site action database to ensure the actions are assigned to the relevant people and completed.

Audits shall be carried out by personnel who have the necessary qualifications and experience to make an objective assessment of the issues. The extent of the audit, although pre-determined, may be extended if a potentially serious deviation from this document is detected.

Any audit non-conformances and/or improvement opportunities will have corrective and preventative actions implemented to avoid recurrence, these actions will be loaded into the site Incident Database to ensure the actions are assigned to the relevant people and completed.

External audits will be conducted utilising external specialists and will consider this document and related documents. External auditors shall be determined based on skills and experience and upon what is to be accomplished.

An Independent Environmental Audit (IEA) was undertaken in 2022. In accordance with SSD-5465 Schedule 6, Condition 9, IEA's will be scheduled for every three years thereafter (unless the Secretary directs otherwise) by an audit team whose appointment has been endorsed by the Secretary.

Review Date	Next Review Date	Revision No	Document Owner	Page
16/01/2024	16/01/2027	7	Environmental Compliance and Approvals Coordinator	Page 39 of 75
<b>DOCUMENT UNCONTROLLED WHEN PRINTED</b>				

## 9 Records and Document Control

### 9.1 Records

Generally, the Environmental Compliance Coordinator will maintain all Environmental Management System records which are not of a confidential nature. Records that will be maintained include:

- monitoring data and equipment calibration;
- environmental inspections and auditing results;
- environmental incident reports;
- the complaints register; and
- licences and permits.

All records will be stored so that they are legible, readily retrievable and protected against damage, deterioration and loss. Records will be maintained for a minimum of 4 years or as otherwise required under any legislation, licence, lease, permit or approval.

### 9.2 Document Control

This document and all others associated with the Environmental Management System shall be maintained in a document control system which is in compliance with the site Document Control Standard which is available to all site personnel. Any proposed change to this document will be via the Environmental Compliance Coordinator. Details on document revisions are provided in **Table 9**.

**Table 9: Document Revision Details**

Version	Date	Details of Revision	Company	Reviewed by/ Authorised by
1	23/08/2012	Revision 1	LakeCoal	GSS Environmental Chris Ellis
2	21/07/2015	Revision 2	LakeCoal	Niche Environment and Heritage Chris Ellis
3	30/11/2019	Updated to Delta Coal format and site update and results	Delta Coal EMM Consulting	Sally Callander Chris Armit Katie Weekes
4	18/12/2020 17/12/2020 5/3/2021 6/4/2021	Updated for Modification 3 and updated Groundwater Management Plan for Extraction Plan  DPIE RFI  DPIE Approval	Delta Coal	Chris Armit
5	24 August 2021	Administrative update following approval of Modification 4	Delta Coal	Lachlan McWha

Review Date	Next Review Date	Revision No	Document Owner	Page
16/01/2024	16/01/2027	7	Environmental Compliance and Approvals Coordinator	Page 40 of 75



TITLE Water Management Plan  
DOC ID ENV 00002 – Water Management Plan  
SITE Chain Valley Colliery

Version	Date	Details of Revision	Company	Reviewed by/ Authorised by
6	1 November 2022	Update following completion of 2022 Independent Environmental Audit	Delta Coal	Lachlan McWha
7	16 January 2024	Update following variation to EPL 1770, varying conditions in water modelling and reflecting the completion of site municipal sewer connection (PRP 8 and PRP 9)	Delta Coal	Lachlan McWha

Review Date	Next Review Date	Revision No	Document Owner	Page
16/01/2024	16/01/2027	7	Environmental Compliance and Approvals Coordinator	Page 41 of 75

**DOCUMENT UNCONTROLLED WHEN PRINTED**

## 10 Roles and Responsibilities

### 10.1 Responsibilities

All employees and contractors of Chain Valley Colliery are responsible for environmental management. However, various positions in the organisation have roles, responsibilities and authorities for managing environmental aspects, action plans, programs and controls.

Roles and responsibilities specific to completing the requirements of this WMP are identified in **Table 10**.

**Table 10: Water Management Roles and Responsibilities**

Role	Responsibilities
General Manager	<ul style="list-style-type: none"> <li>Ensure that adequate financial and personnel resources are made available for the implementation of the WMP.</li> </ul>
Manager of Mining Engineering	<ul style="list-style-type: none"> <li>Overall responsibility for environmental compliance with Mining Lease, EPL, Development Consent and other mining approvals as they pertain to water management.</li> </ul>
Environmental Compliance and Approvals Coordinator	<ul style="list-style-type: none"> <li>Implementing the forward works program;</li> <li>Planning for adequate resources to implement this site WMP.</li> <li>Approving revised versions of this site WMP;</li> <li>Co-ordination of external audits, corporate reporting and management;</li> <li>Co-ordinate environmental monitoring, reporting, inspections, environmental training, authority liaison, maintaining complaints register and community liaison;</li> <li>Allocation of resources within area of responsibility and budget;</li> <li>The implementation and adherence to this site WMP;</li> <li>Providing adequate training to employees and contractors regarding their requirements under this site WMP;</li> <li>Contractor management; and</li> <li>Delegating tasks associated with this site WMP when responsible personnel are absent.</li> </ul>
Employees and contractors	<ul style="list-style-type: none"> <li>Comply with the requirements of this WMP.</li> </ul>

Review Date	Next Review Date	Revision No	Document Owner	Page
16/01/2024	16/01/2027	7	Environmental Compliance and Approvals Coordinator	Page 42 of 75

## 11 References & Associated Documents

Documents used in the preparation of this management plan are detailed in **Table 11**.

**Table 11: References and Associated Documents**

Reference Type	Document
Australian standards	<p>AS/NZS ISO 14001:2004 <i>Environmental management systems – Requirements with guidance for use</i></p> <p>AS/NZS ISO 14004:2004 <i>Environmental management systems – General guidelines on principles, systems and support techniques</i></p>
Legislation and regulations	<p>NSW EPA, EPL 1770 <i>Environment Protection License 1770</i></p> <p>Development Consent SSD-5465 (Modification 2) dated 16 December 2015 for the Mining Extension 1 Project</p> <p><i>Environmental Planning and Assessment Act 1979</i></p> <p><i>Mining Act 1992</i></p> <p><i>Protection of the Environment Operations Act, 1997</i></p> <p><i>Water Act 1912</i></p> <p><i>Water Management Act 2000</i></p>
Delta Coal documents	<p>Delta Coal - Environmental Management Strategy</p> <p>GSS Environmental – Chain Valley Colliery Mining Extensions 1 Project - Surface Water Assessment March 2013 (GSSE 2013)</p> <p>LakeCoal, 2019. Chain Valley Colliery Annual Review 2018. Doc No. REP 00058, 16 May 2019.</p> <p>Delta Coal, 2020. Chain Valley Colliery Annual Review 2019.</p> <p>GHD – Groundwater Impact Assessment, Chain Valley Colliery Consolidation Project, 7 October 2022.</p>
External documents	<p>Australian and New Zealand Environment Conservation Council (ANZECC) and the Agriculture and Resource Management Council of Australia and New Zealand (ARMCANZ), National Guidelines for Sewerage Systems - Effluent Management, 1997.</p> <p>Australian and New Zealand Environment Conservation Council (ANZECC) and the Agriculture and Resource Management Council of Australia and New Zealand (ARMCANZ), Australian and New Zealand Guidelines for Fresh and Marine Water Quality (ANZECC Guidelines), October 2000.</p> <p>ANZG 2018. Australian and New Zealand Guidelines for Fresh and Marine Water Quality. Australian and New Zealand Governments and Australian state and territory governments, Canberra ACT, Australia. Available at <a href="http://www.waterquality.gov.au/anz-guidelines">www.waterquality.gov.au/anz-guidelines</a></p> <p>Australian Government, Charter: National Water Quality Management Strategy, 2018.</p>

Review Date	Next Review Date	Revision No	Document Owner	Page
16/01/2024	16/01/2027	7	Environmental Compliance and Approvals Coordinator	Page 43 of 75



TITLE Water Management Plan  
 DOC ID ENV 00002 – Water Management Plan  
 SITE Chain Valley Colliery

	<p>DECCW, March 2004. Approved Methods for Sampling and Analysis of Water Pollutants in NSW.</p> <p>Douglas Partners, 2020, Geotechnical assessment for Sewer Pipeline, Chain Valley Colliery.</p> <p>GEOTERRA, 2020, Groundwater Management Plan, Chain Valley Colliery.</p> <p>GEOTERRA, 2019, Groundwater Management Plan, Chain Valley Colliery.</p> <p>GEOTERRA, 2014, Groundwater Management Plan, Chain Valley Colliery.</p> <p>GEOTERRA, March 2013, Chain Valley Colliery Mining Extension 1 Groundwater Assessment.</p> <p>GSS Environmental, March 2013, Chain Valley Mining Extension 1 Project Surface Water Assessment. (GSSE 2013)</p> <p>Landcom, 2004 and Department of Environment and Climate Change (DECC), 2008. Managing Urban Stormwater: Soils and Construction (the Blue Book), Volume 1 and Volume 2E – Mines and Quarries.</p> <p>NSW Water Quality and River Flow Objectives, September 1999.</p> <p>NSW State Rivers and Estuaries Policy, 1993.</p> <p>NSW Groundwater Quality Protection Policy, adopted in 1998.</p> <p>NSW Groundwater Quantity Management Policy.</p> <p>NSW Department of Environment and Conservation (DEC), Environmental Guidelines: Use of Effluent by Irrigation, 2004.</p> <p>The NSW State Groundwater Dependent Ecosystems Policy, adopted in 2002.</p>
--	--

Review Date	Next Review Date	Revision No	Document Owner	Page
16/01/2024	16/01/2027	7	Environmental Compliance and Approvals Coordinator	Page 44 of 75

**DOCUMENT UNCONTROLLED WHEN PRINTED**

## 12 Definitions

**ANZECC** Australia New Zealand Environment Conservation Council

**AWTS** Aerated Waste Water Treatment System

**CC Council** – Central Coast Council

**DECCW** Former NSW Department of Environment, Climate Change and Water

**DP&E** NSW Department of Planning and Environment (former)

**DPIE** NSW Department of Planning, Industry and Environment

**DoI - Water** NSW Department of Industry (Water)

**DRE** Division of Resources and Energy (within the Department of Trade and Investment, Regional Infrastructure and Services)

**EPA** Environment Protection Authority

**EP&A Act** Environmental Planning and Assessment Act 1979

**EPL** Environment Protection License

**GwMP** Groundwater Management Plan

**LDP** Licensed Discharge Point

**LMCC** Lake Macquarie City Council

**MPL** Mining Purposes Lease

**Mt** Million Tonnes

**NOW** NSW Office of Water (former)

**OEH** Office of Environment and Heritage

**POEO Act** *Protection of the Environment Operations Act 1997*

**ROM** Run of Mine

**Planning Secretary** Planning Secretary of the Department of Planning, Industry and Environment, or nominee

**SSD-5465** Development Consent SSD-5465 (for the Chain Valley Colliery Mining Extension 1 Project)

**TARP** Trigger Action Response Plan

**TSS** Total Suspended Solids

**WMP** Water Management Plan

**WSC** Wyong Shire Council (now part of Central Coast Council)

Review Date	Next Review Date	Revision No	Document Owner	Page
16/01/2024	16/01/2027	7	Environmental Compliance and Approvals Coordinator	Page 45 of 75



TITLE Water Management Plan  
DOC ID ENV 00002 – Water Management Plan  
SITE Chain Valley Colliery

**Appendix 1: Groundwater Management Plan (GwMP)**

---

Review Date	Next Review Date	Revision No	Document Owner	Page
16/01/2024	16/01/2027	7	Environmental Compliance and Approvals Coordinator	Page 46 of 75

**DOCUMENT UNCONTROLLED WHEN PRINTED**



**GeoTerra**

**DELTA COAL PTY LTD  
CHAIN VALLEY COLLIERY  
GROUNDWATER MANAGEMENT PLAN**

CVC3-R4A  
15 December 2020

**GeoTerra** Pty Ltd **ABN 82 117 674 941**

PO Box 220 Canterbury NSW 2193

Phone: 02 9787 9137 Fax: 02 9787 1874 Mobile 0417 003 502 Email: [geoterra@inet.net.au](mailto:geoterra@inet.net.au)

Authorised on behalf of GeoTerra Pty Ltd:	
<b>Name:</b>	Andrew Dawkins
<b>Signature:</b>	
<b>Position:</b>	Principal Hydrogeologist

Date	Rev.	Comments
21.05.2020		Initial Draft
15.12.2020	A	Final

## TABLE OF CONTENTS

<b>1. INTRODUCTION</b>	<b>4</b>
1.1 Objectives	5
1.2 Scope	6
1.3 Definitions	6
1.4 Limitations	6
<b>2. LEGISLATION</b>	<b>8</b>
2.1 Water Management Act 2000	8
2.2 State Groundwater Policy	8
2.2.1 Groundwater Quality Protection	9
2.2.2 Groundwater Dependent Ecosystems	9
2.2.3 Groundwater Quantity Protection	10
<b>3. CURRENT AND PROPOSED OPERATIONS</b>	<b>11</b>
3.1 Adjacent Workings	12
3.2 Predicted Subsidence	12
3.3 Rainfall and Evaporation	13
<b>4. LOCAL GROUNDWATER SYSTEM</b>	<b>14</b>
4.1 Alluvial Aquifers	15
4.2 Lake Macquarie Sediments	15
4.3 Shallow Bedrock	15
4.4 Deep Bedrock	15
4.5 Coal Seams	16
4.6 Structure and Intrusions	16
4.7 Private Bores Within or Adjacent to the Proposed Mining Area	17
4.8 Regional Groundwater Use	18
<b>5. GROUNDWATER IMPACTS FROM PREVIOUS MINING</b>	<b>19</b>
5.1 Wyee State Mine	19
5.2 Private Bores	20
5.3 Potable Mine Water Supply	20
5.4 Licensed Mine Water Discharges	20
5.5 Mine Water Pumping and Mine Groundwater Inflow	20

<b>5.6</b>	<b>Mine Groundwater Quality</b>	<b>21</b>
<b>6.</b>	<b>POTENTIAL GROUNDWATER IMPACTS</b>	<b>24</b>
<b>6.1</b>	<b>Hydraulic Connection to Lake Macquarie</b>	<b>24</b>
<b>6.2</b>	<b>Aquifer / Aquitard Interconnection</b>	<b>24</b>
<b>6.3</b>	<b>Regional Groundwater Depressurisation</b>	<b>25</b>
<b>6.4</b>	<b>Private Bore Yields and Serviceability</b>	<b>25</b>
<b>6.5</b>	<b>Groundwater Dependent Ecosystems</b>	<b>26</b>
<b>6.6</b>	<b>Groundwater Quality</b>	<b>26</b>
<b>6.7</b>	<b>Groundwater Seepage to or From Terrestrial Streams</b>	<b>27</b>
<b>6.8</b>	<b>Groundwater Inflow to Mine Workings</b>	<b>27</b>
<b>7.</b>	<b>GROUNDWATER MONITORING PLAN</b>	<b>28</b>
<b>7.1</b>	<b>Mine Groundwater Inflow</b>	<b>28</b>
<b>7.2</b>	<b>Private Bore Water Levels</b>	<b>28</b>
<b>7.3</b>	<b>Groundwater Quality</b>	<b>29</b>
	7.3.1 Inactive Private Bores	29
	7.3.2 Active Private Bores	29
<b>7.4</b>	<b>Groundwater Contamination</b>	<b>30</b>
<b>8.</b>	<b>GROUNDWATER ASSESSMENT CRITERIA AND TRIGGERS</b>	<b>31</b>
<b>8.1</b>	<b>Mine Water Extraction and Discharge</b>	<b>31</b>
<b>8.2</b>	<b>Private Bore Groundwater Levels</b>	<b>32</b>
<b>8.3</b>	<b>Private Bore Groundwater Quality</b>	<b>32</b>
<b>9.</b>	<b>POTENTIAL GROUNDWATER AMELIORATIVE ACTIONS</b>	<b>33</b>
<b>9.1</b>	<b>Private Bore Yield</b>	<b>33</b>
<b>9.2</b>	<b>Private Bore Groundwater Quality</b>	<b>33</b>
<b>10.</b>	<b>CONTINGENCIES</b>	<b>34</b>
<b>11.</b>	<b>AUDIT AND REVIEW</b>	<b>34</b>
<b>11.1</b>	<b>Internal Audits</b>	<b>34</b>
<b>11.2</b>	<b>External Audits</b>	<b>35</b>
<b>12.</b>	<b>RECORDS</b>	<b>35</b>

<b>13. RESPONSIBILITIES AND ACCOUNTABILITIES</b>	35
13.1 General Manager	35
13.2 Environment and Community Coordinator	35
13.3 Hydrogeologist / Hydrologist	36
<b>14. TRAINING</b>	36
<b>15. REPORTING</b>	36
15.1 Annual Environmental Management Report	36
<b>16. REFERENCES</b>	37

**FIGURES**

Figure 1 Current and Proposed Workings and Private Bore Locations .....	7
Figure 2 Local Area Stratigraphy .....	14
Figure 3 Faulting in the Vicinity of MW S5 .....	17
Figure 4 Annual Mine Dewatering Volumes.....	21
Figure 5 Mine Water Chemistry .....	23

**TABLES**

TABLE 1 Maximum Predicted Subsidence .....	12
TABLE 2 Maximum Observed Subsidence .....	13
TABLE 3 Rainfall and Evaporation Summary Data.....	13
TABLE 4 Registered Local Private Bores .....	18
TABLE 5 Water Chemistry - Major Ions .....	22
TABLE 6 Water Chemistry - Metals .....	22
TABLE 7 Mine Water Chemistry .....	22
TABLE 8 Suggested Producing Groundwater Bore Water Level Monitoring .....	29
TABLE 9 Suggested Producing groundwater Bore Water Quality Monitoring .....	30
TABLE 10 Groundwater Quality Monitoring Parameters .....	30
TABLE 11 Groundwater Chemistry Criteria (mg/L).....	32

## 1. INTRODUCTION

This revised Groundwater Monitoring Program (GwMP) has been prepared in compliance with Schedule 3 (Condition 18D) of the Delta Coal Pty Ltd (DC) Chain Valley Colliery Extension Project Approval SSD 5465 for the addition of Miniwall S5.

Development Consent (SSD-5465 – as modified) was approved on 23 December 2013 which permits the current and proposed activities.

This report is to be read in conjunction with the Water Management Plan prepared for Chain Valley Colliery (Delta Coal, 2019).

This GwMP includes:

- a groundwater water quality and quantity monitoring program;
- trigger levels for mining impacts on groundwater systems;
- procedures to be followed in the event that monitoring of groundwater indicates an exceedance of trigger levels;
- measures to mitigate, remediate and/or compensate for identified impacts;
- a protocol for the notification of trigger level exceedances, and;
- a contingency plan where, in the event of adverse effects on groundwater quality and/or quantity due to mining impacts, Chain Valley Colliery will provide an equivalent supply until the affected supply is restored, or as agreed with the landowner and the NSW Department of Industry - Water (DPIE).

Groundwater related operations at Chain Valley Colliery include the:

- historic Great Northern and Wallarah seams bord and pillar workings;
- current Fassifern Seam development as well as miniwall workings; and
- water storage and management facilities owned and operated by Chain Valley Colliery.

Operation of the GwMP needs a high level of management input to operate Chain Valley Colliery within the relevant requirements and various water licences, particularly to ensure compliance with the water discharges authorised by Environment Protection Licence (EPL) 1770.

An essential part of the plan is monitoring of all groundwater inflows and extraction into and out of the underground with reliable flow meters, as well as monitoring of groundwater levels and water quality in private bores.

This information is necessary for periodical reviews of the groundwater management system and to support any updates/changes to licences.

The proposed mitigation measures minimise and manage the impacts of any potential adverse effects on local aquifers within the GwMP area.

The proposed mitigation measures minimise, where possible, the impacts of the proposed mining on the various groundwater sources, aquifers or groundwater dependent ecosystems that may be present in the Project Area.

## 1.1 Objectives

The objective of the GwMP is to operate Chain Valley Colliery so that the subsurface mining operations will be conducted in a manner which minimises the potential impacts on groundwater flow and quality, aquifer integrity, groundwater dependent ecosystems and other off-site groundwater related impacts.

In order to achieve this goal, the GwMP will be used to establish procedures to:

- measure, control, mitigate and repair potential impacts that could, or do, occur to the groundwater system overlying Chain Valley Colliery; and
- identify, measure, minimise or where possible, avoid potential significant adverse impacts that can result from mining and subsidence on the groundwater systems within the Project Area.

In addition, the GwMP will be used to:

- monitor groundwater system changes in relation to the leaseholder's mining activities;
- assess the pre and post-mining condition of groundwater systems in the lease area;
- ensure all relevant groundwater criteria are met;
- minimise and manage any impacts on the availability of groundwater to potentially impacted residents, landholders or other groundwater users;
- minimise adverse changes on groundwater dependent ecosystems, where present;
- provide a forum to record and discuss mining impacts; and
- provide an annual report on the monitoring, observations and actions conducted within the preceding 12 months to the Department of Planning, Industry and Environment (DPIE).

These objectives will be met by:

- monitoring groundwater seepage and groundwater quality in the workings during mining within the mine lease area;
- installation of water monitoring appliance(s) to measure pumped water volumes to and from the mine workings. These appliances will be maintained in good working order. If required the mine will supply a test certificate to certify the current accuracy of the appliance(s) furnished by the manufacturer or by some duly qualified person or organisation. The mine water pumping records will be maintained and supplied to DPIE at the end of the water year;
- ensuring that any tail-water drainage will not be allowed to discharge onto adjoining roads, crown land or other lands, or into any unauthorised stream, or any aquifer, by surface or subsurface drains or pipes or any other means without appropriate approval;
- ensuring that any groundwater extracted from the works will not be discharged into any watercourse or source of groundwater except in compliance with the Protection of the Environment Operations Act (1997);
- any works used for the purpose of conveying, distributing or storing groundwater from the works will not be constructed or installed so as to obstruct the free passage of floodwaters flowing in, to or from a river or lake;
- all groundwater extracted from the works will be used or applied only on such land, and for such purposes, as approved by DPIE, and;
- providing a forum to report, discuss and record impacts to the groundwater system that involves the Chain Valley Colliery, stakeholders and DPIE, as required.

## 1.2 Scope

The GwMP is to be used to protect, monitor and manage the condition of the groundwater system within the Chain Valley Colliery lease area that may potentially be impacted due to coal mining and mine subsidence.

It applies to persons employed or engaged by Chain Valley Colliery when carrying out activities described by this plan.

This GwMP is to be read in conjunction with the current version of the Water Management Plan (WMP) which outlines the monitoring and management of specific factors relating to surface water and groundwater issues due to the predicted subsidence.

All other water management components not directly related to the GwMP are contained as part of the WMP.

The plan covers mining until completion of Domains 1 and 2, although the plan may be used beyond that benchmark with appropriate modification.

## 1.3 Definitions

For the purpose of this document, the area addressed in the GwMP is defined as the groundwater systems within the Chain Valley Colliery project approval area. The main features in the GwMP area shown in **Figure 1** include the:

- current Chain Valley Colliery workings in the Fassifern Seam;
- the proposed extraction within Domains 1 and 2; and
- the current and proposed extraction of Miniwalls S2, S3, S4 and S5.

## 1.4 Limitations

This GwMP is based on current monitoring data and the proposed and approved operational aspects relating to Chain Valley Colliery. The relevant groundwater features have been identified from:

- existing studies;
- data supplied by Chain Valley Colliery representatives; and
- associated consultant's reports in the Lake Macquarie area.

The impacts of mining on the groundwater system have been assessed in previous studies (see references). However, it is recognised that prediction and assessment of changes to, and effects from, operation of the Colliery on the groundwater system can be relied upon only to a certain extent.

The groundwater study prepared for the Chain Valley Colliery Mining Extension 1 Groundwater Assessment (GeoTerra, 2013) determined there is a low potential for the mine's impacts on the groundwater system to exceed the predictions and assessments. However, the possibility of impacts above predictions has been considered in this plan.

The plan will not necessarily prevent impacts from the proposed mining, but does identify appropriate procedures to manage the impacts within tolerable limits and identifies procedures that can be followed should evidence of increased impacts and unacceptable risk emerge.

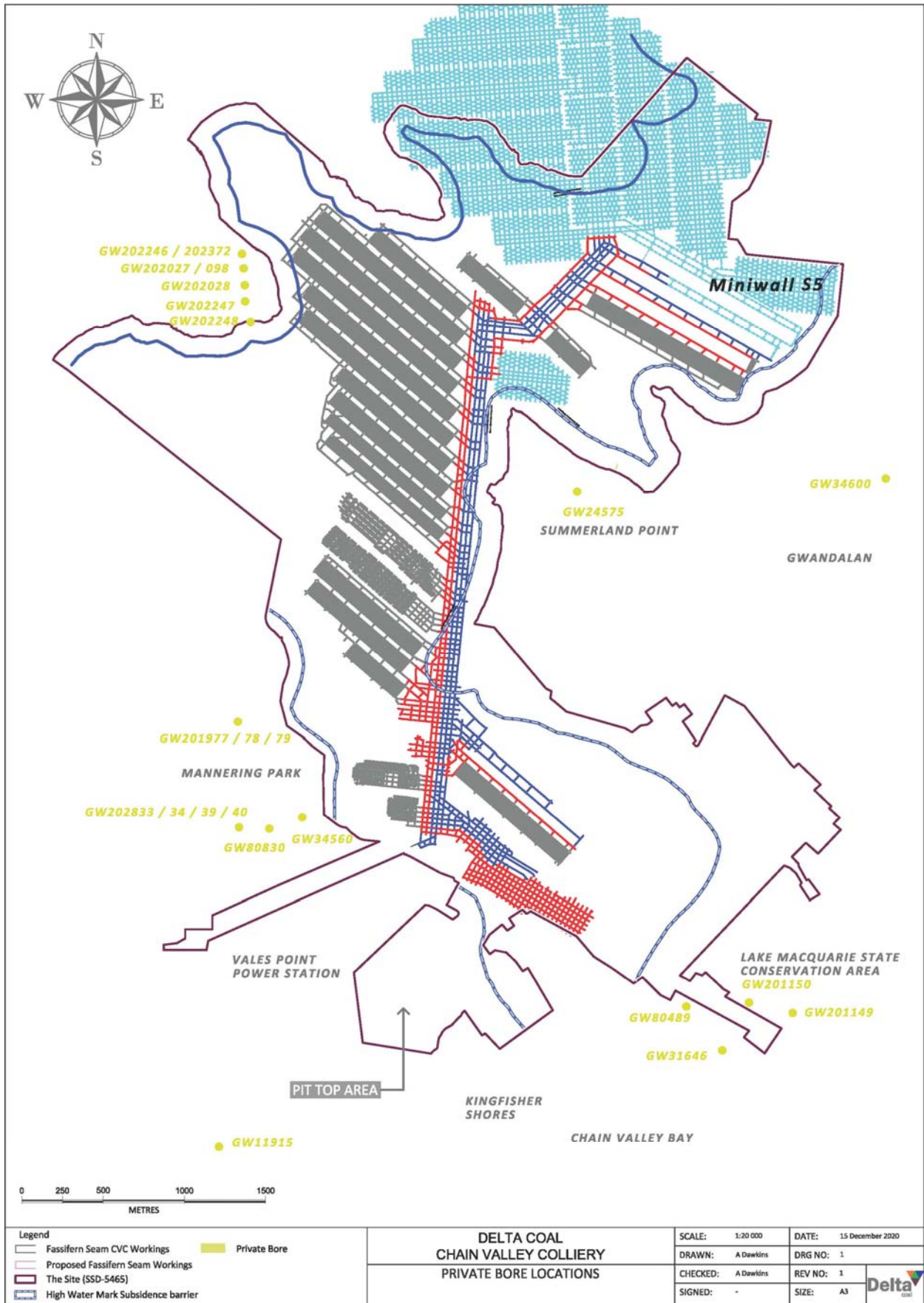

**Figure 1 Current and Proposed Workings and Private Bore Locations**

## 2. LEGISLATION

The following sub-sections outline NSW statutory requirements that apply to the mining operation with respect to groundwater.

### 2.1 Water Management Act 2000

The key legislation for the management of water in the project area is the *Water Management Act 2000* (the Act), which regulates water use for rivers and aquifers where water sharing plans have commenced.

Under the Act, DPIE has prepared a range of statutory water management plans covering aspects such as water sharing, water use, drainage management and floodplain management. In NSW, 36 water sharing plans have commenced, covering 80 percent of water currently extracted. The plans cover most of the regulated river systems (those controlled by major dams for rural water supplies), a number of unregulated river systems and the major inland alluvial aquifers.

The project area is located in the *South Lake Macquarie Water Source* section of the Water Sharing Plan - Hunter unregulated water sources.

The object of the Act is the sustainable and integrated management of the State's water for the benefit of both present and future generations. The Act provides arrangements for controlling land-based activities that affect the quality and quantity of the State's water resources. It provides for four types of approval:

- water use approvals – authorise the use of water at a specified location for a particular purpose, for up to ten years;
- water management work approvals;
- controlled activity approvals; and
- aquifer interference activity approvals – authorise the holder to conduct activities that affect the aquifer. This approval is for activities that intersect groundwater, other than water supply bores and may be issued for up to ten years.

For controlled activities and aquifer interference activities, the Act requires that the activities avoid or minimise impacts on the water resource and land degradation, and where possible the land must be rehabilitated.

### 2.2 State Groundwater Policy

The *NSW State Groundwater Policy* (Framework Document) was adopted in 1997 and aims to manage the State's groundwater resources to sustain their environmental, social and economic uses. The policy has three component parts:

- The *NSW Groundwater Quality Protection Policy*, adopted in December 1998;
- The *NSW State Groundwater Dependent Ecosystems Policy*, adopted in 2002; and
- The *NSW Groundwater Quantity Management Policy*.

### 2.2.1 Groundwater Quality Protection

The *NSW Groundwater Quality Protection Policy* (Department of Land and Water Conservation, 1998), states that the objectives of the policy will be achieved by applying the management principles listed below.

- all groundwater systems should be managed such that their most sensitive identified beneficial use (or environmental value) is maintained;
- town water supplies should be afforded special protection against contamination;
- groundwater pollution should be prevented so that future remediation is not required;
- for new developments, the scale and scope of work required to demonstrate adequate groundwater protection shall be commensurate with the risk the development poses to a groundwater system and the value of the groundwater resource;
- a groundwater pumper shall bear the responsibility for environmental damage or degradation caused by using groundwater that is incompatible with soil, vegetation and receiving waters;
- groundwater dependent ecosystems will be afforded protection;
- groundwater quality protection should be integrated with the management of groundwater quality;
- the cumulative impacts of developments on groundwater quality should be recognised by all those who manage, use, or impact on the resource; and
- where possible and practical, environmentally degraded areas should be rehabilitated and their ecosystem support functions restored.

### 2.2.2 Groundwater Dependent Ecosystems

The *NSW State Groundwater Dependent Ecosystems Policy* (Department of Land and Water Conservation, 2002) is specifically designed to protect valuable ecosystems which rely on groundwater for survival so that, wherever possible, the ecological processes and biodiversity of these dependent ecosystems are maintained or restored for the benefit of present and future generations. The policy defines Groundwater Dependent Ecosystems (GDEs), as “*communities of plants, animals and other organisms whose extent and life processes are dependent on groundwater*”.

Five management principles establish a framework by which groundwater is managed in ways that ensure, whenever possible, that ecological processes in dependent ecosystems are maintained or restored. A summary of the principles follows:

- GDEs can have important values. Threats should be identified and action taken to protect them;
- groundwater extractions should be managed within the sustainable yield of aquifers;
- priority should be given to ensure that sufficient groundwater is available at all time to identified GDEs;
- where scientific knowledge is lacking, the precautionary principle should be applied to protect GDEs; and
- planning, approval and management of developments should aim to minimise adverse effects on groundwater by maintaining natural patterns, not polluting or causing changes to groundwater quality and rehabilitating degraded groundwater systems.

### 2.2.3 Groundwater Quantity Protection

The objectives of managing groundwater quantity in NSW are to:

- achieve the efficient, equitable and sustainable use of the State's groundwater;
- prevent, halt and reverse degradation of the State's groundwater and/or its dependent ecosystems;
- provide opportunities for development which generate the most cultural, social and economic benefits to the community, region, state and nation, within the context of environmental sustainability; and
- involve the community in the management of groundwater resources.

### 3. CURRENT AND PROPOSED OPERATIONS

Chain Valley Colliery is an underground coal mine operated by Delta Coal Pty Ltd (Delta Coal).

The Colliery is located in the Newcastle Coalfields at the southern end of Lake Macquarie in NSW, and is approximately 60 kilometres south of Newcastle, within the Swansea-North Entrance Mine Subsidence District.

The project area incorporates the relatively flat pit top area, existing ventilation shaft and fan site on Summerland Point, as well as foreshore areas and Lake Macquarie.

The terrestrial land within the GwMP area is gently undulating and drains to Lake Macquarie.

Chain Valley Colliery commenced operation in the 1960's extracting coal from the Wallarah seam, the Great Northern Seam and the Fassifern Seam, and currently conducts mining within leases ML 1051, CCL 721 and ML 1632.

The current Fassifern Seam Miniwalls are located underneath Lake Macquarie, within and to the north of Chain Valley Bay.

The mine has completed extraction of Miniwalls 1 to 12 (MW1 to MW12) and has an approved Extraction Plan for Miniwalls N1 and S1, S2, S3 and S4 in the Fassifern Seam.

At the time of writing, the Chain Valley Colliery has completed miniwall S2.

No current or proposed secondary extraction underlies any terrestrial based surface water catchments, with all secondary extraction proposed to be underneath the saline, tidal region of Lake Macquarie.

Chain Valley Colliery currently has Development Consent (SSD-5465 – as modified) for:

- extraction of up to a maximum of 2.1 million tonnes per annum until 31 December 2027 through continued mining via first workings and miniwall methods within the Fassifern Seam;
- continued coal transport for the surface facilities site;
- continued use of the existing surface facilities, and;
- continuation of passive underground activities within the old workings of the Wallarah seam, Great Northern seam and the Fassifern Seam.

The approved mining area is approximately 200m below the sediments of Lake Macquarie, within a boundary set to exclude secondary extraction within the High Water Mark Subsidence Barrier or the Seagrass Protection Barrier.

Bord and pillar mining was commenced in the Fassifern Seam in 2006 and secondary extraction in the form of miniwall mining method in the Fassifern Seam commenced in 2011.

The S3 miniwall panel is being mined at 97m wide (rib to rib) with a 40m wide inter-panel pillar, whilst the proposed miniwall panels S4 and S5 will have the same width.

These panel widths are significantly less than previously proposed for Chain Valley and adjacent mines – for example, at Wyee Colliery Longwalls 17 to 21 were up to 150m wide, and were extracted between 150m and 180m below surface.

Historically, Chain Valley Colliery has mined within the Wallarah and Great Northern seams to the east with via bord and pillar methods, while to the south west and west Wyee State Mine (now named Mannering Colliery) has mined the Great Northern and Fassifern seams using bord and pillar and longwall extraction.

Mining within the Wallarah and Great Northern Seams will not be undertaken as part of the Project.

The maximum water depth within the proposed mining areas is greater than 5m, whilst sediment on the bottom of the lake is less than 5m thick over Miniwall S5.

Above the Fassifern Seam over Miniwall S5, overburden (including the lake sediments), ranges from 144 - 161m with a rock cover thickness of 139 – 157m (Strata<sup>2</sup>, 2020).

The maximum height of connective fracturing is predicted to be between 79 to 82m for Miniwall S5 according to the Ditton and Merrick (2014) approach, however, where the spanning influence of the 26 – 30m thick Teralba conglomerate is factored in, the potential height ranges from 45 to 50m above the workings (Strata<sup>2</sup>, 2020).

### 3.1 Adjacent Workings

Chain Valley Colliery is entirely surrounded by the existing Mannering, Myuna and Wallarah Collieries as well as by the historic Newvale and Moonee Collieries.

Mannering Colliery (formerly the Wyee State Mine), has conducted longwall mining in the Great Northern and Fassifern seams since the 1960s. Extraction continued until 2002, when mining became uneconomic. The mine was temporarily shut down until 2004 when it was reopened by Centennial Coal. Since 2004, mining progressed in the Fassifern Seam using bord and pillar methods.

The Myuna Colliery commenced operation in 1981 and is currently mining the Fassifern Seam via bord and pillar techniques.

Walarah Colliery operated from 1979 until 2002, when it was placed under care and maintenance.

Munmorah, Mandalong and Cooranbong Collieries are also nearby, but are not immediately adjacent to the Chain Valley Colliery holding boundary.

### 3.2 Predicted Subsidence

The maximum subsidence after completion of mining will be located under Lake Macquarie, with the 20mm subsidence line to be contained within the lake high water mark (Strata<sup>2</sup>, 2020).

The maximum predicted subsidence, tilts and strains over the proposed workings (assuming a 170m depth of cover) are summarised in **Table 1**.

**TABLE 1 Maximum Predicted Subsidence**

<b>Parameter</b>	<b>After Extraction of Miniwall S5</b>
<b>Vertical subsidence</b>	350 mm
<b>Tilt</b>	5 mm/m
<b>Strain (Compressive and Tensile)</b>	2 mm/m

To date, the maximum subsidence has been observed as summarised in **Table 2**.

**TABLE 2 Maximum Observed Subsidence**

Location	Maximum Subsidence (m)
MW1	0.20
MW2	0.40
MW3	0.70
MW4	0.22
MW5	0.46
MW6	0.80
MW7	0.90
MW8	1.00
MW9	1.20
MW10	0.90
MW11	0.60
MW12	0.30
CVB1	0.45
MW S1	<0.1
MW N1	<0.1
MW S2	<0.1
MW S3	<0.15

It is predicted there will be no observable subsidence at the lake foreshore, lake high water mark, or the sea grass beds (Strata<sup>2</sup>, 2020).

### 3.3 Rainfall and Evaporation

Analysis of climate data from the Bureau of Meteorology (BoM) weather station at Peats Ridge indicates the following rainfall data as shown in **Table 3**.

**TABLE 3 Rainfall and Evaporation Summary Data**

	Rainfall (mm/year)	Evaporation (mm/year)
Maximum	2186	1420
90 <sup>th</sup> Percentile	1685	1247
75 <sup>th</sup> Percentile	1418	1210
Median	1226	1170
20 <sup>th</sup> Percentile	902	1090
Minimum	567	410

#### 4. LOCAL GROUNDWATER SYSTEM

For management purposes, groundwater within the GwMP area has been divided into the following classes:

- **(Mine water)** groundwater and town water that is pumped into or out of the underground workings;
- **(Groundwater)** water contained within strata overlying the mine workings; and
- **(Seeps and springs)** groundwater that discharges to surface water catchments within the project area.

Groundwater flows from the “terrestrial” recharge areas, outside of Lake Macquarie, as well as from the saline waters of Lake Macquarie into the overburden under a regional hydraulic gradient, with dominantly horizontal confined flow along discrete discontinuities and fractures within bedding planes, and / or above fine grained, relatively impermeable strata within the overburden sequence.

The overburden generally contains low yielding aquifers with low hydraulic conductivities. A schematic of the stratigraphic sequence is shown in **Figure 2**.

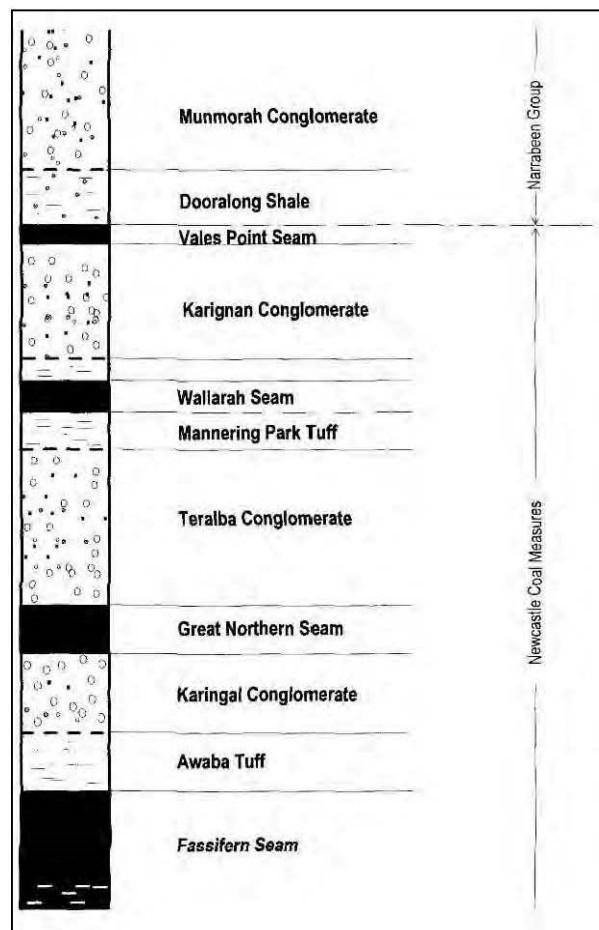

**Figure 2 Local Area Stratigraphy**

#### 4.1 Alluvial Aquifers

Quaternary to recent alluvial terrestrial sediments comprising sand, gravel, clay and silt are associated with creeks and drainage channels in the local area, to the east, west and south on the shores of Lake Macquarie.

Alluvium in the vicinity of the project area is likely to be present associated with the drainage lines which discharge to Lake Macquarie.

No data is available for the thickness or lithology of alluvium within the project area. However, it is anticipated, if present, to be thin, with limited aerial extent, and no significant water storage or transmitting capacity.

Alluvial sediments within the “terrestrial” areas, outside of the project area, are generally too shallow and limited in extent to be used for groundwater supply.

#### 4.2 Lake Macquarie Sediments

Sediments in the vicinity of MWS2 – S5 within Lake Macquarie consist of unconsolidated sands, clays, silts and gravels from 5 - 23m thick.

#### 4.3 Shallow Bedrock

The shallow bedrock comprises weathered bedrock which potentially contains discontinuous perched aquifers. These have developed at the interface between the soil and bedrock and along zones of locally increased permeabilities caused by weathering of bedrock and faulting.

The depth and permeability of any aquifers is likely to be dependent on the depth of weathering and the extent and frequency of any permeable fracture systems.

Recharge to the shallow bedrock aquifer is primarily through rainfall infiltration, with some infiltration into the underlying basement through fractures, joints and faults.

#### 4.4 Deep Bedrock

The Newcastle Coal Measures are overlain by the Munmorah Conglomerate and the Dooralong Shale of the Triassic Narrabeen Group which comprise the majority of the overburden.

The Munmorah Conglomerate extends to a depth of approximately 120m in the vicinity of the project area and comprises mostly quartz-lithic sandstone interbedded with pebble conglomerate.

The Dooralong Shale is up 20m thick and comprises cross-bedded sandstone intercalated with siltstone and claystone (Forster and Enever, 1992).

Fractured bedrock aquifers would be present within the Narrabeen Group and the Newcastle Coal Measures with discrete water yielding horizons associated with zones of increased permeability i.e. faults and the coal seams.

The overburden and interburden is a low yielding sequence of essentially dry conglomerates and shales.

Joints and fractures associated with fractured bedrock systems tend to be laterally and vertically discontinuous, resulting in poor hydraulic connection and low groundwater yields.

Forster and Enever (1992) state that “*neither the Narrabeen Group nor the Newcastle Coal Measures contain any significant quantities of groundwater and their permeabilities are known to be generally low (<10<sup>-7</sup> m/s).*”

*Any permeable zones which do occur are usually due to jointing, faulting and shearing on bedding planes.*

*Because of the extremely low permeability of the rock substance, groundwater flow through the overburden strata is almost exclusively by interconnecting defects such as joints and bedding.*

*For this reason, coal seams with their interconnecting cleat and joint patterns are often found to be 'aquifers' relative to the surrounding strata. Despite this, most underground coal mines on the Central Coast are quite dry, and rarely have any major groundwater problems."*

Groundwater in the deep bedrock aquifer is of poor quality with salinity levels ranging from 3000 to 16,000  $\mu\text{S}/\text{cm}$ .

Recharge to the deep bedrock aquifer is generally from infiltration of rainfall from overlying aquifers and the flow direction is expected to reflect the local topography.

#### 4.5 Coal Seams

The coal deposits historically or currently mined in the area include the Wallarah, Great Northern and Fassifern seams of the Newcastle Coal Measures which are generally interbedded with tuffaceous claystone.

The coal seams generally have a low primary or inter-granular porosity and permeability, with bedding planes, joints, fractures and cleating imparting an enhanced secondary permeability.

The 4.5 – 5.5m thick Fassifern Seam underlies the Wallarah and Great Northern seams within the project area, and lies between 139 - 157m below surface, with a proposed mining height of up to 3.5m.

#### 4.6 Structure and Intrusions

The overburden dips at approximately two degrees to the south-west.

Superimposed on the regional dip is the Macquarie Syncline, with an axis that runs through the Chain Valley Colliery holding, along with associated faulting and igneous intrusions.

Mapped and inferred geological structures in the project area indicate that MW S5 is expected to extract through the following inferred geological structures:

- at the inbye end, an igneous dyke up to 2m thick, and;
- in the outbye half of the panel, a normal fault with a throw of <1m.

There is also an inferred 3m fault at the outbye end of TG S5, but this is not projected to traverse the MW S5 extraction area.

The fault plane will almost certainly extend upwards through the Fractured and Constrained Zones. However, given that:

- voussoir beam analysis suggests that such a feature would not appreciably impact on the spanning ability of the Teralba Conglomerate; and
- the favourable experiences from previous extraction panels with much greater exposure to major structures,

this fault is considered to be of no material consequence.

**Figure 3** shows the major structural features, based on in-seam drilling, mapping in adjacent areas / seams and exploration drilling results. The MW S2 to S4 panels are orientated at  $119^\circ$ , rather than the  $134^\circ$  of earlier CVC panels which is more favourable with respect to the dominant  $131^\circ$  structural direction.

Overall, the structural environment is considered to have no significant adverse implications for S5 panel subsidence and sub-surface fracturing.

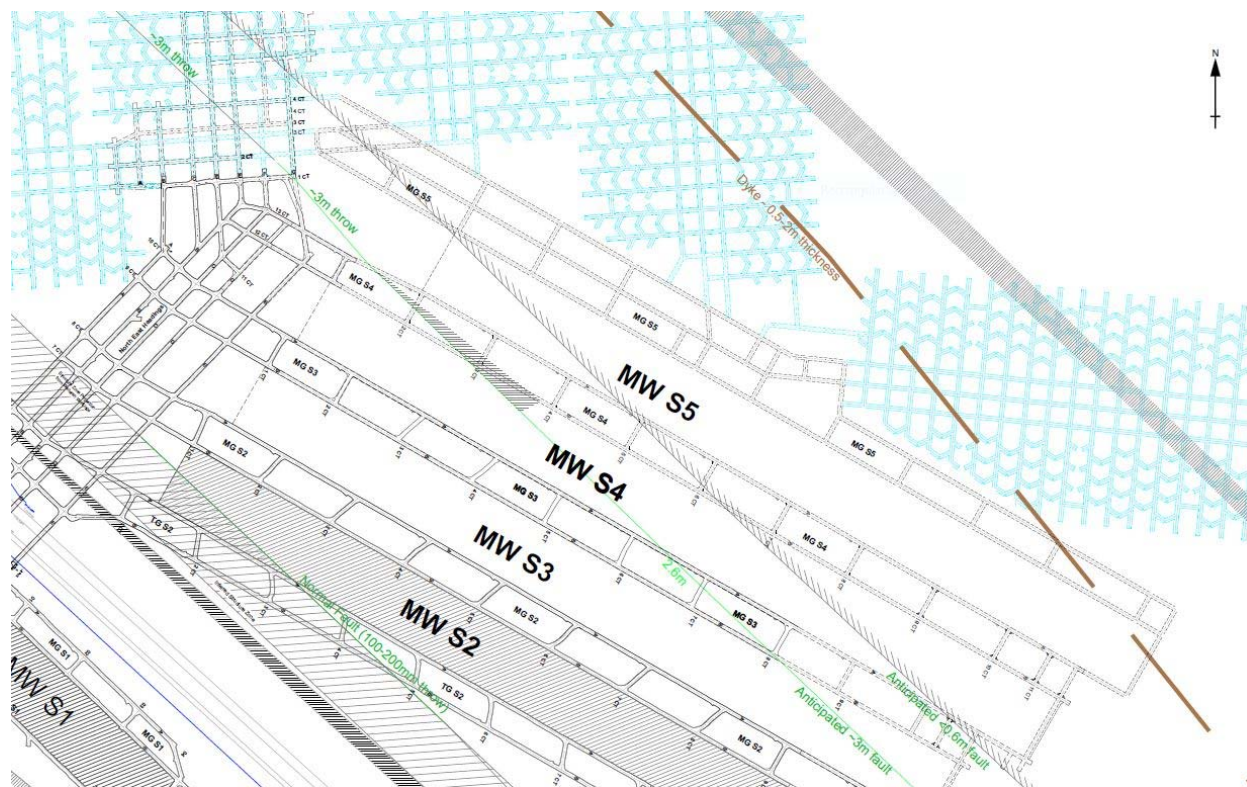

**Figure 3** Faulting in the Vicinity of MW S5

#### 4.7 Private Bores Within or Adjacent to the Proposed Mining Area

Twenty three DPIE registered bores are (or were) located within or near the GwMP area as shown in **Figure 1** and **Table 4**.

From the available data, the majority of bores are completed in shallow (<18.3) meters below ground level (mbgl) sandy alluvium with one coal exploration bore converted for use as a domestic water supply (GW31646).

Many shallow (<7 mbgl) deep test bores are present in the area, along with some shallow (<7.2 mbgl) monitoring bores.

Most of the deeper remnant private bores in the GwMP area are potentially used for domestic garden or limited irrigation water supply.

Where the data is available from the DPIE records, groundwater has been obtained from the shallow sandy alluvial / colluvial aquifers with low to moderate yields ranging from 0.13 L/sec to 1.50 L/sec.

**TABLE 4 Registered Local Private Bores**

GW	E	N	Drilled	Depth (m)	SWL (m)	Aquifer (mbgl)	YIELD (L/s)	Purpose	Bore Currency
11915	363007	6329604	-	5.4	-	-	-	Poultry	no response
24575	365969	6332788	1965	15.2	-	-	-	Domestic	no response
31646	366742	6329317	1960	277.5	3.0	3.0 – 10.6	0.13	Dom. / Coal Explore	not present
34560	364130	6330883	1970	18.3	5.5	5.5	-	Domestic	not present
34600	367678	6332873	1971	61.0	5.7	18.2	0.06	Waste disposal	-
80489	366441	6329674	2003	-	-	-	-	Domestic	no internal access
80830	363757	6330850	2004	-	-	-	-	Test bore	capped / covered
201149	367104	6329608	2006	4.0	1.0	1.0 – 4.0	1.50	Irrigation spear	no response
201150	366840	6329640	2006	4.0	1.0	1.0 – 4.0	1.50	Irrigation spear	no response
201977	363730	6331388	2008	7.1	6.0	6.0 – 7.0	-	Monitoring	-
201978	363712	6331391	2008	7.1	6.0	6.0 – 7.0	-	Monitoring	-
201979	363704	6331405	2008	7.2	6.0	6.0 – 7.0	-	Monitoring	-
202027	363829	6334141	2007	3.7	-	-	-	Test bore	not present
202028	363872	6334034	2007	5.5	1.6	-	-	Test bore	not present
202098	363829	6334141	2007	4.0	0.8	-	-	Test bore	not present
202246	363834	6334174	2007	3.5	1.2	0.6 – 3.5	-	Test bore	not present
202247	363899	6333964	2007	5.0	3.6	2.0 – 5.1	-	Test bore	not present
202248	363918	6333881	2007	5.0	-	2.0 – 5.0	-	Test bore	not present
202372	363834	6334174	2007	4.0	-	-	-	Test bore	not present
202833	363568	6330876	2013	6.5	2.50	2.5 – 3.5	-	Monitoring bore	-
202834	363563	6330861	2013	6.5	2.50	2.5 – 3.5	-	Monitoring bore	-
202839	363574	6330883	2013	7.2	2.5	2.5 - 3.5	-	Monitoring bore	-
202840	363573	6330859	2013	5	2.0	2.0 – 3.0	-	Monitoring bore	-

**Note:** - no data available SWL = standing water level

#### 4.8 Regional Groundwater Use

Registered bores in the vicinity of the GwMP area are generally installed into the Munmorah Conglomerate to a maximum depth of 61m, with the majority of bores installed to less than 30m.

Groundwater yields are generally less than 1 L/s, with one bore reporting a yield of 5 L/s.

The authorised uses of the bores include:

- stock watering;
- poultry;
- industrial;
- domestic; and
- waste disposal.

While it is recognised that not all existing bores are likely to be registered, the database gives an indication of groundwater usage in the area.

Overall, it is concluded that the importance and reliance on groundwater by local landowners and residents is limited.

## 5. GROUNDWATER IMPACTS FROM PREVIOUS MINING

The Chain Valley Mine is surrounded by other collieries which have been extracting coal from as early as the 1940s using both longwall and bord and pillar methods.

Historical and current mining operations have resulted in extensive dewatering and depressurisation within and overlying the extracted coal seams.

Water is pumped out of the mines which results in a lowering of the potentiometric surface within the overlying aquifers.

Due to the extent of mining in the region, the subsidence effects would have partly depressurised the overburden.

### 5.1 Wyee State Mine

An extensive study by Forster and Enever (1992) at the adjacent Wyee State Mine (now called Mannering Colliery) assessed the impact of 150 m wide longwall mining on the hydrogeological properties of the overburden.

The study assessed that longwall mining of the Great Northern Seam resulted in measurable changes in the hydrogeological properties over a large proportion of the overburden as a result of the redistribution of stresses. The changes reported for the overburden were:

- **Upper Strata** (more than 115 m above the Great Northern Seam) –the hydrogeological properties of the strata after mining were generally similar to those measured prior to mining. Some strata reported a temporary drop in piezometric pressure which recovered soon after the completion of mining in that area.
- **Intermediate Strata** (65 to 115 m above the Great Northern Seam) – experienced significant permanent piezometric pressure increases after mining. The cause of the increase in pressure was uncertain, however it was concluded that *“since the intermediate strata have not lost piezometric pressure, it is certain that significant vertical drainage has not occurred from these strata and they have formed an effective barrier against vertical hydraulic connection between the surface and the mine.”*
- **Lower Strata** (less than 65 m above the Great Northern Seam) – showed significant increased permeability and permanent decreases in piezometric pressure which indicated that significant cracking has occurred and allowed partial drainage into the workings.

Although measured changes in the lower strata indicate hydraulic connection was generated and groundwater seepage to the workings had occurred, the changes in the intermediate and upper strata was not significant, and were due to minor strata movements and the formation of fractures that were vertically discontinuous.

It was assessed that the intermediate and upper strata would form a barrier to vertical drainage and that aquifers from 65 – 115 m above the workings should not be hydraulically vertically connected to the workings, and should not be drained as a result of subsidence.

Aquifers greater than 115 m above the mine workings should not be impacted at all.

It should be noted that the subsidence studied over the Wyee State Mine related to 150 m wide longwalls, whilst the maximum width of the proposed Chain Valley miniwalls is 97 m, with 30.6 m wide pillars. As a result, the predicted subsidence and the height of fracturing over the proposed workings will be significantly less than was observed over the Wyee State Mine longwalls.

## 5.2 Private Bores

No adverse changes to bore yields, pumping flow duration or groundwater quality have been observed or reported in private bores within the GwMP area.

## 5.3 Potable Mine Water Supply

The mine has a potable water supply connection from the Wyong Council town-water system.

Historically, a range of 132 – 162 ML/year of potable water is supplied to Chain Valley Colliery, of which approximately 15% is used for pit top operations and 85% is used for dust suppression in the underground.

As required by Schedule 3, Condition 18(b) of SSD-5465, practical measures to minimise potable water consumption and maximise recycled water use have been implemented and continue to be investigated by Delta Coal, as discussed in the associated WMP. However, the use of non-potable water in all operational activities is not possible due to its quality, work health and safety and equipment requirements.

## 5.4 Licensed Mine Water Discharges

The discharge of mine water from the sedimentation and pollution control ponds is licensed under the *Protection of the Environment Operations Act 1997* by the Environment Protection Authority (EPA).

Under EPL No. 1770 there is a single licensed discharge point for Chain Valley Colliery (LDP1), which has a maximum discharge volume of 12,161 kL/day.

The Colliery obtained a 4,443 ML/year groundwater licence (20BL173107) on the 12<sup>th</sup> March 2013 under the *Water Act, 1912* to enable water to be pumped from the underground workings to the sedimentation and pollution control ponds at the pit top.

## 5.5 Mine Water Pumping and Mine Groundwater Inflow

Historic data indicates that 1,914 – 2,536.4 ML/year of mine water has been extracted via two pumps in the Great Northern Seam workings sump, with a reduction in extraction volumes being evident over the last 3 years as shown in **Figure 4**.

The net groundwater seepage into the workings is estimated from the difference between the annual potable water intake and the annual water volume extracted from the underground workings.

The latest annual groundwater make (2019) from the mine is estimated at 1,913 ML/yr, or 5.24 ML/day.

Temporary increases in groundwater inflows to the mine have been reported in the vicinity of faults and associated fractures. The increases in inflow are usually short lived as the structures associated with fractured bedrock systems tend to be laterally and vertically discontinuous, resulting in poor hydraulic connection and have low groundwater yields (GeoTerra, 2013).

In general, the Fassifern Seam has to date been the driest seam, whilst mining of the overlying Wallarah Seam has been conducted without major adverse impacts to the overlying aquifers or inflow of water from Lake Macquarie (GeoTerra, 2013).

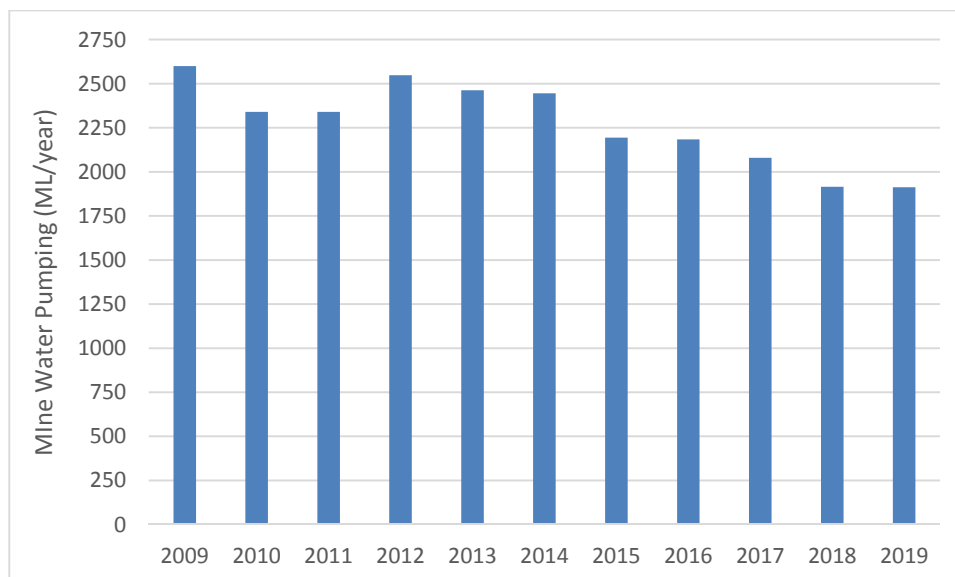

**Figure 4 Annual Mine Dewatering Volumes**

### 5.6 Mine Groundwater Quality

Groundwater monitored within the current and historic underground mining areas in the Chain Valley Colliery indicates the inflow water is brackish to relatively saline in subsided areas over the Great Northern Seam workings (11,800 – 28,200 mg/L) with a circum-neutral to mildly alkaline pH (7.30 – 7.76).

Groundwater seepage from a dyke at the northern end of the current Fassifern Seam workings, over the unsubsided main headings, had a brackish salinity of 2,390 mg/L and an alkaline pH of 8.63 as shown in **Tables 5** and **6**.

The data indicates that groundwater within the underground is significantly above the ANZECC (2000) water quality criteria (the default trigger values for physical & chemical stressors in SE Australian lowland rivers and 95% protection of freshwater species) for:

- pH (Fassifern dyke);
- electrolytical conductivity (all samples);
- total nitrogen (all samples);
- total phosphorous (Fassifern dyke); as well as,
- filterable copper (Great Northern Seam sump , Fassifern dyke); and
- filterable zinc (all samples except GNS2).

The exceedance in the mine water seepage depends on the guideline applied for the end use of the water.

The groundwater seepage is not generally suitable for potable, livestock or irrigation use, but is suitable for discharge under EPL 1770.

**TABLE 5 Water Chemistry - Major Ions**

	pH	EC (uS/cm)	TDS	Na	Ca	K	Mg	Cl	F	HCO <sub>3</sub>	SO <sub>4</sub>	Total P	Total N	DOC
<b>ANZECC 2000</b>	6.5 -8.0	2,200	-	-	-	-	-	-	-	-	-	0.05	0.5	-
Karignan Ck	6.93	185	100	29	2.2	2.3	3.5	54	0.10	10	6	<b>0.15</b>	<b>0.6</b>	17
Chain Valley Bay	7.64	47,300	36,100	10500	470	470	1100	19400	1.3	125	2200	<b>0.06</b>	0.4	<1
<b>GNS SUMP</b>	7.48	35,600	23,200	7640	590	125	690	13600	0.25	360	1200	0.04	<b>2.3</b>	2
<b>GNS1 (roof)</b>	7.30	40,400	28,200	7980	730	80	840	15600	0.47	435	1320	<0.01	<b>3.4</b>	<1
<b>GNS2 (pond)</b>	7.76	19,500	11,800	3950	140	38	230	6730	0.57	385	250	0.02	<b>0.6</b>	3
<b>Fassifern dyke</b>	<b>8.63</b>	3,500	2,390	925	1.9	9.1	2.1	310	5.6	2040	7	<b>0.65</b>	<b>4.1</b>	3

NOTE: all values in mg/L

samples collected 22/6/2012

**TABLE 6 Water Chemistry - Metals**

	Fe(T)	Fe	Mn(T)	Mn	Cu	Pb	Zn	Ni	Al	As	Li	Ba	Sr
<b>ANZECC 2000</b>	-	-	1.9	1.9	0.0014	0.0034	0.008	0.011	0.055	0.013 / 0.024	-	-	-
Karignan Ck	1.3	0.82	0.03	0.03	<b>0.003</b>	<0.001	<b>0.014</b>	<0.01	0.05	<0.01	<0.001	0.026	0.10
Chain Valley Bay	0.10	0.02	0.02	0.01	<b>0.003</b>	<0.001	<b>0.013</b>	<0.01	0.03	<0.01	0.38	0.041	4.8
<b>GNS SUMP</b>	0.18	0.07	0.06	0.04	<b>0.004</b>	<0.001	<b>0.018</b>	<0.01	0.04	<0.01	0.98	0.084	31
<b>GNS1 (roof)</b>	0.12	0.07	0.27	0.16	<0.001	<0.001	<b>0.010</b>	<0.01	0.03	<0.01	1.3	0.080	44
<b>GNS2 (pond)</b>	0.05	<0.01	<0.01	<0.01	<0.001	<0.001	0.003	<0.01	0.01	<0.01	0.59	0.17	11
<b>Fassifern dyke</b>	2.4	0.08	0.06	0.02	<b>0.004</b>	<0.001	<b>0.019</b>	<0.01	0.04	<0.01	0.28	0.37	1.0

NOTE: all values in mg/L

metals reported as acidified and 45um filtered samples except where Total (T) values are shown

samples collected 22/6/2012

Analysis of selected areas within the workings and in Lake Macquarie on 14<sup>th</sup> February 2020 was conducted as summarised in **Table 7** and shown as a Piper Diagram in **Figure ?**.

**TABLE 7 Mine Water Chemistry**

	pH	EC (uS/cm)	TDS	Na	Ca	K	Mg	Cl	F	HCO <sub>3</sub>	CO <sub>3</sub>	SO <sub>4</sub>	TP
<b>ANZECC 2000</b>	<b>6.5 - 8.0</b>	<b>2,200</b>	-	-	-	-	-	-	-	-	-	-	<b>0.05</b>
TGS2 (Goaf Fassi)	8.54	13900	6710	3220	28	11	20	4320	n/a	899	82	<b>40</b>	<b>0.17</b>
S2 Face (Fassi)	8.46	14600	7810	3240	41	10	15	4410	n/a	917	80	<b>47</b>	<b>&lt;0.05</b>
11KV Switch )Roof GN Conglomerate)	7.73	33000	19600	n/a	n/a	n/a	n/a	n/a	n/a	n/a	n/a	n/a	<0.05
Lake Macquarie	8.14	52100	34900	10800	414	389	1300	16000	n/a	106	<1	2680	<0.05

NOTE: all values in mg/L except as shown samples collected on 14/2/2020

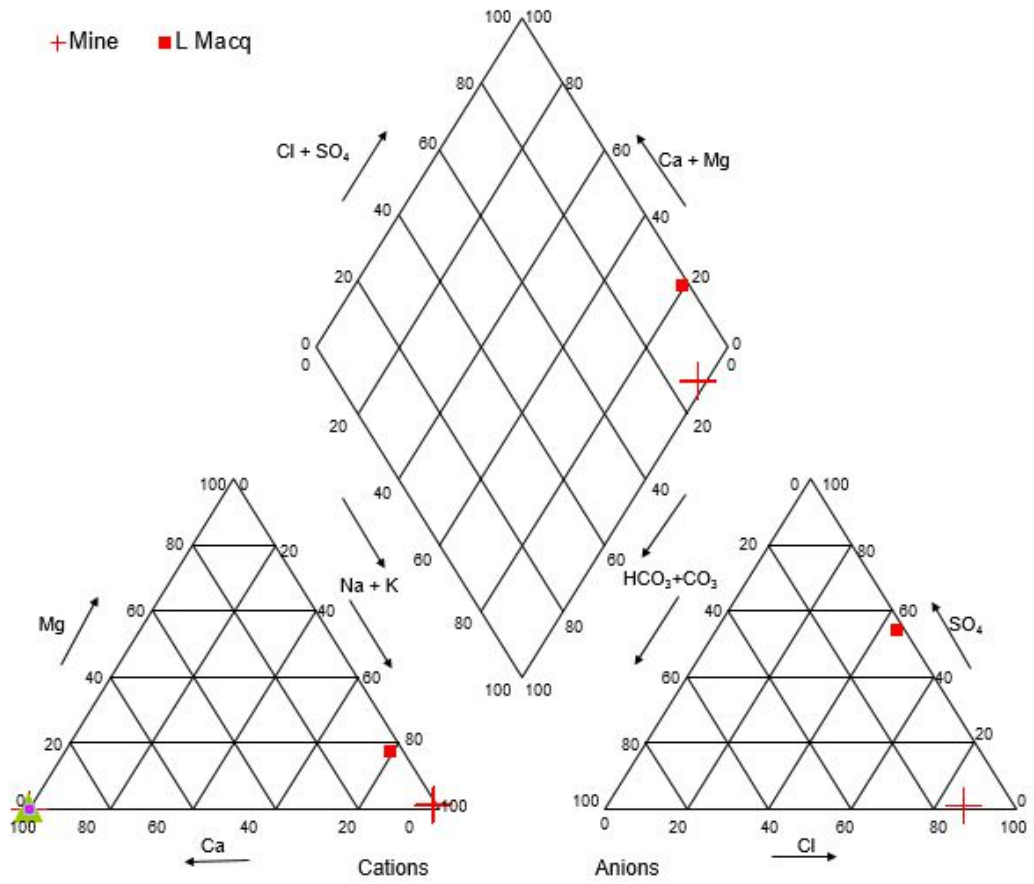

Figure 5 Mine Water Chemistry

## 6. POTENTIAL GROUNDWATER IMPACTS

It is anticipated that subsidence over the 144 - 161 m deep proposed S5 miniwall workings may affect the overlying groundwater system through:

- surface cracking to approximately 20m below surface;
- height of connective fracturing to less than 50 m above the seam (Strata<sup>2</sup>, 2020), with partial loss of groundwater if fracturing extends into an overlying aquifer, which can cause minor groundwater inflow from the goaf to the workings;
- an exponential decrease in overburden permeability with height above the workings;
- connectivity between the mine workings and overlying aquifers within the fractured goaf, which can result in depressurisation of the aquifers;
- dewatering and depressurisation of the Great Northern and Fassifern seams as mining progresses;
- increased aquifer permeability, and, potentially;
- reduced groundwater quality in the overlying aquifers.

### 6.1 Hydraulic Connection to Lake Macquarie

The Forster and Enever (1992) study at Wyee State Mine, with 150 m wide longwalls, indicated there was no hydraulic connection at heights over 115 m above the extracted workings.

It should be noted that the proposed miniwall has a maximum width of 97 m, which means the height of fracturing would be less than that observed over the 150 m wide Wyee State Mine longwalls.

As a result, hydraulic connection between Chain Valley Colliery and Lake Macquarie over the proposed secondary extraction workings associated with Miniwall S5 is not anticipated as the minimum depth of cover is at least 144 m (including lake bed sediments), or from 139 m of basement (excluding the sediments in Lake Macquarie).

### 6.2 Aquifer / Aquitard Interconnection

Mining induced cracking and vertical subsidence of strata over the extraction area may potentially extend up to 20 m below surface, with bedding dilation from below the surface zone down to the upper goaf.

In the upper horizons, subsidence can alter the dominance of the pre-mining horizontal flow along or above aquitards to generate a combination of vertical and horizontal flow regimes as aquitards are breached and water drains to lower elevations in the strata.

Vertical flow continues down the strata until the drainage is restricted by intact aquitards, at which the depth the flow then resumes its horizontal dominance.

Below the surface cracked zone, an increase in horizontal flow component can occur due to dilation and bending of strata, even though the layers are not actually breached by vertical cracking. The increased horizontal permeability extends across the subsided area, gradually diminishing as the subsidence and dilation decreases out to the edge of the subsidence zone.

No adverse interconnection of aquifers and aquitards is anticipated within 20 m of the lake bed as there are no recorded aquifers in this interval.

However, there may be an increased rate of recharge into the upper overburden from the lake waters due to the increased secondary porosity and permeability of the subsided, fractured overburden.

### **6.3 Regional Groundwater Depressurisation**

Extensive mining of the Fassifern, Wallarah and Great Northern seams at Chain Valley and surrounding collieries for more than 60 years has significantly depressurised the overburden within the vicinity of the proposed workings.

Groundwater levels within the Fassifern Seam has already been extensively impacted by mining in the area and therefore continued mining is likely to have little additional impact, if any.

The deeper basement lithologies have increased permeability in areas of partial or full extraction due to subsidence induced caving and fracturing over the workings which results in an increased groundwater storage capacity of the overburden through increased secondary porosity.

Groundwater flow rates within the deeper aquifers are likely to increase within the caved and fractured areas due to greater hydraulic connectivity between horizontal and vertical fractures.

A temporary lowering of the regional piezometric surface over the subsidence area of up to 1.0 m due to horizontal dilation of strata may occur due to the increase in secondary porosity and permeability (GeoTerra, 2013). This effect will be more notable directly over the area of greatest subsidence and dilation, and will dissipate laterally out to the edge of the subsidence zone.

Based on similar observations in NSW with similar mining layouts, surficial and mid depth strata groundwater levels may reduce by up to 15m, and may stay at that reduced level until maximum subsidence develops at a specific location. The duration of the reduction depends on the time required to develop maximum subsidence, the time for subsidence effects to migrate away from a location as mining advances to subsequent panels, and the length of time required to recharge the secondary voids.

The degree of groundwater level decline under the lake due to subsidence is predominantly determined by the proximity to a mined panel, however it can also be significantly affected by the rate of lake water infiltration and terrestrial rainfall recharge to an aquifer, as well as changes in the rate or duration of groundwater extraction in any adjacent groundwater bores.

On the basis that the pre-mining circumstances of lake water and rainfall recharge as well as any local bore pumping remain the same, it is anticipated that groundwater levels will recover over a few months as the secondary void space is recharged by lake water and rainfall infiltration.

There is generally no permanent post mining reduction in groundwater levels under the lake, as no new hydraulically connected outflow paths from within the overburden develop.

### **6.4 Private Bore Yields and Serviceability**

Although registered bore sites are located within the predicted 1.0 m groundwater depressurisation area, no private bore yields or serviceability have historically been reported to be, or are predicted to be affected by subsidence or regional groundwater depressurisation associated with the proposed workings, which are entirely located under Lake Macquarie.

No beneficial users of the deep bedrock/coal measures aquifers have been identified in the vicinity of the GwMP Area.

## 6.5 Groundwater Dependent Ecosystems

Cumulative impacts from the proposed mining are not anticipated to adversely impact on groundwater dependant ecosystems in the 20 mm subsidence area.

This is primarily because no groundwater dependent ecosystems have been identified in the proposed subsidence area within or under Lake Macquarie.

## 6.6 Groundwater Quality

Previous observations in NSW Coalfields indicates that groundwater quality within the subsided overburden is not generally adversely affected, however there may be increased iron hydroxide precipitation and a lowering of pH if the groundwater is exposed to “fresh” surfaces in the strata with dissolution of unweathered iron sulfide (marcasite) or iron carbonate (siderite).

The degree of iron hydroxide and pH change due to subsidence is difficult to predict, and can range from no observable effect to a distinct discolouration of water pumped out of bores.

The discolouration does not pose a health hazard, however it can cause clogging of pumping equipment and piping in extreme cases.

It should be noted that many bores in the local area can already have significant iron hydroxide levels, and a pre-mining survey of the active bores is required to assess the baseline water quality prior to undermining.

Acidity (pH) changes of up to 1 order of magnitude can occur, however the change can be reduced if the bore has sufficient bicarbonate levels.

The potential for groundwater contamination also exists from spills of fuels, oils and chemicals from both the surface and underground mine workings. Spills may result in the contamination of soil, while the infiltration of rainfall or direct migration of contaminants to the water table has the potential to contaminate shallow aquifers.

The potential for impacts can be minimised through the appropriate storage of fuels and hazardous chemicals, the implementation of appropriate work procedures and regular inspections and maintenance of equipment and plant.

Leaks and spills should be handled in accordance with the PIRMP prepared for the site, and remediated as required on a case by case basis.

Infiltration of potentially contaminated water from the sedimentation dams also has the potential to impact groundwater quality. As the dams receive all site runoff, amenities water and mine water, as well as workshop and wash down water after treatment by an oil separator, there is potential for the water within the dams to be contaminated by dissolved petroleum hydrocarbons and heavy metals. It is understood the dams are not lined with a low permeability layer, and as such, seepage of potentially contaminated water within the dams may be infiltrating alluvial or shallow aquifers.

### **6.7 Groundwater Seepage to or From Terrestrial Streams**

No known springs or streams are present in the GwMP area that would be affected by subsidence and associated regional groundwater depressurisation with the existing and proposed workings.

Overall, the terrestrial streams within the GwMP area will be subjected to no or very low tensile and compressive strains and are not anticipated to be adversely affected by subsidence related stream bed cracking.

No loss of overall stream flow or regional change in stream water quality within the local streams is anticipated to occur.

### **6.8 Groundwater Inflow to Mine Workings**

Loss of lake water or any significant loss of connate groundwater within the overburden to the underlying workings has not been observed in mines in the local area at similar depths of cover to the proposed workings.

Vertical hydraulic connection to the workings is anticipated to be restricted by the Dooralong Shale and the Mannering Park Tuff aquitards, which are not anticipated to be breached by subsidence over the proposed Fassifern Seam workings and are both below the surficial and above the goaf, vertically connected, dilation zones.

The horizontal permeability above and between the aquitards may be enhanced after subsidence, however there is no additional vertical connectivity through or below them to the underlying workings.

Based on available records, the 2019 annual groundwater seepage into the workings was 1,913 ML/yr, or 5.24 ML/day.

No obvious relationship between expansion of the mine and increased groundwater inflow to the workings is evident in the current data, with a reduction in mine water pumping evident over the last three years.

Based on a groundwater modelling assessment (GeoTerra, 2013) the inflow may increase up to 10.5 ML/day as the Colliery expands.

## 7. GROUNDWATER MONITORING PLAN

The groundwater monitoring program at available (or currently present) locations shown in **Figure 1** is designed to provide a database that enables:

- comparison of anticipated vs observed impacts on the groundwater system through miniwall as well as bord and pillar extraction of the Fassifern Seam at Chain Valley Colliery and any associated subsidence effects; and
- procedures to assess, manage or rehabilitate any adverse effects that exceed specified trigger levels.

As the proposed workings, and the anticipated associated subsidence impacts, are wholly located underneath or within Lake Macquarie, the monitoring plan specifically deals with the following issues.

### 7.1 Mine Groundwater Inflow

The active underground mining area should be monitored by the underground supervisors to assess whether observable groundwater inflow is occurring to the active panels and if any changes are noted.

Water flow monitoring appliances have been installed to measure pumped water volumes to and from the mine workings. These appliances will be maintained in good working order, and if required, DC will supply a test certificate to certify the current accuracy of the appliances furnished by the manufacturer or by some duly qualified person or organisation.

Daily total mine water pumping records will be maintained, plotted and interpreted annually and will be supplied to DPIE within the Annual Environmental Management Report (AEMR).

### 7.2 Private Bore Water Levels

Where property access is granted and access inside a producing groundwater bore is possible, water levels within the private bores could be measured at least once before and once after mining is conducted in the GwMP area to assess if any adverse effects due to subsidence have occurred as shown in **Table 8**.

It is suggested that all other shallow monitoring or test bores, or waste disposal bores are not to be included in the monitoring suite.

Where monitoring of groundwater levels is not possible due to installed pump head-works, the mine will assess any reports from landowners in regard to adverse effects on bore water availability that may occur during or after extraction of the proposed workings.

Each property owner may be interviewed before and after the proposed mining to assess the bore's status, pumping rate, and its general duration of pumping as well as the type and set up of the pump.

Where feasible, the bore yield should also be measured, and water levels measured where access inside the bore is possible.

Where private bores are being occasionally or frequently pumped, and could thereby temporarily distort the static regional groundwater levels, the depth to groundwater, where accessible, should be monitored during pump resting periods to assess the regional piezometric surface across the area.

**TABLE 8 Suggested Producing Groundwater Bore Water Level Monitoring**

GW	Monitoring Frequency	Monitoring Method	Units
11915	Upon access / post mining	Dip meter	mbgl
24575	Upon access / post mining	Dip meter	mbgl
80489	Upon access / post mining	Dip meter	mbgl

**Note:** mbgl = metres below ground level

### 7.3 Groundwater Quality

#### 7.3.1 Inactive Private Bores

Where property access is granted and access inside a bore is possible, a pre-mining water sample collection and analysis will be conducted within one month of access being granted and available, and will be repeated at the end of mining in the project area to enable assessment of any subsidence related changes in groundwater quality.

Each bore will be purged prior to sampling until pH and salinity measurements stabilise, which usually involves removal of at least three bore volumes of water.

Samples will be collected, appropriately preserved, kept on ice and transported under chain of custody documentation to arrive at the laboratory within appropriate holding times.

In addition, each piezometer or inactive bore will be monitored in the field for bi-monthly salinity ( $\mu\text{S}/\text{cm}$ ) and pH measurements.

#### 7.3.2 Active Private Bores

Where property access is granted and access to the groundwater bore is possible, an initial water sample collection and analysis will be conducted within one month of access being granted and available, and will be repeated at the end of mining in the project area to enable assessment of any subsidence related changes in groundwater quality.

To date, access to one current bore has been granted (GW80489), however no sample could be obtained as the installed pump was not working.

The use, and any treatment, of the bore water should be ascertained and observations made on the quantum of iron hydroxide precipitating from the pumped water before and after mining.

Each bore will be purged prior to sampling until pH and salinity measurements stabilise, which usually involves removal of at least three bore volumes of water.

Samples will be collected from bores that are current and accessible as shown in **Table 9**, and will be appropriately preserved, kept on ice and transported under chain of custody documentation to arrive at the laboratory within appropriate holding times.

**TABLE 9 Suggested Producing groundwater Bore Water Quality Monitoring**

<b>GW</b>	<b>Monitoring Frequency</b>	<b>Monitoring Method</b>	<b>Units</b>
<b>11915</b>	Upon access / post mining	In situ pump / bailer	pH EC mg/L (ions, metals, nutrients)
<b>24575</b>	Upon access / post mining	In situ pump / bailer	pH EC mg/L (ions, metals, nutrients)
<b>80489</b>	Upon access / post mining	In situ pump / bailer	pH EC mg/L (ions, metals, nutrients)

During extraction within the GwMP area, the frequency of monitoring and the parameters to be monitored may be varied in consultation with DPIE once the baseline groundwater quality and its response to mining (if any) is established.

The frequency of post mining monitoring will be reassessed after mining is complete in the GwMP area as it may be possible, depending on results, to lengthen the intervals.

**Table 10** presents the physical groundwater quality parameters to be measured.

**TABLE 10 Groundwater Quality Monitoring Parameters**

<b>SUITE</b>	<b>ANALYTES</b>
<b>Initial monitoring / after mining is completed</b>	Field EC, Eh, pH, temp TDS, Na, K, Ca, Mg, F, Cl, SO <sub>4</sub> , HCO <sub>3</sub> , NO <sub>3</sub> , Total N, Total P Cu, Pb, Zn, Ni, Fe, Mn, As, Se, Cd, Cr, Li, Ba, Cs, Rb, Sr (filtered)

#### 7.4 Groundwater Contamination

In accordance with the sites' EPL and WMP, surface water discharged from the dams is monitored monthly for a range of pollutants.

The range of analysis for surface water also includes oil and grease, which allows the assessment of impact, if any, that these dams may be having on underlying aquifers.

## 8. GROUNDWATER ASSESSMENT CRITERIA AND TRIGGERS

Management of impacts within predictions follow standard assessment review and response protocols.

Contingent measures are included in this plan to ensure the timely and adequate management of the proposed extraction and subsidence impacts outside of anticipated levels.

Where and if required, specialist hydrogeological / hydrological investigations and reports may include:

- the study scope and objectives;
- consideration of any relevant aspect from this plan;
- analysis of trends;
- assessment of any impacts against prediction;
- assessment of the cause of a change or impact;
- options for management and mitigation;
- assessment for the need for contingency measures;
- any recommended changes to this plan; and
- appropriate consultation with DPIE, DRE and EPA.

Site specific mitigation / remediation action plans may include:

- a description of the impact to be managed;
- results of the specialist investigations;
- aims and objections for the plan;
- specific actions required to mitigate/manage;
- timeframes for implementation;
- roles and responsibilities;
- identification of and gaining appropriate approvals from landholders and government agencies; and
- a consultation and communication plan.

Trigger values for further assessment of potential subsidence effects on groundwater systems within the plan area are discussed in the following sections.

The triggers have been developed to reflect the current variability in relevant parameters and to enable the identification of any changes that may be due to either subsidence effects, landowner impacts and/or natural causes.

If trigger values are exceeded, the cause and effect will be investigated and a management plan developed if it is directly related to mining.

The Environment and Community Coordinator shall be responsible for the implementation of agreed actions and shall communicate such actions to the relevant landowners or authorities.

### 8.1 Mine Water Extraction and Discharge

Chain Valley Colliery holds a DPIE license (WAL41508) to extract up to 4,443 ML/year from the workings, and currently holds EPL 1770 which permits volumetric discharge of up to 12,161 kL/day via its licensed discharge point.

Mine water extraction will be measured daily and daily discharge volumes will be reported on a monthly basis via the DC website.

As part of the AEMR the average monthly groundwater extraction rates will be determined by assessing the difference between the potable water pumped into the workings and the total water pumped out of the workings. This assumes no hydraulic conductivity with Lake Macquarie,

surface potable water leaks, water theft or measurement error.

A trigger for the groundwater extraction will be where the monthly average extracted underground mine water exceeds **10.5 ML/day** (75<sup>th</sup> percentile groundwater inflow – refer **Table 3**), and this average continues for at least 2 months.

## 8.2 Private Bore Groundwater Levels

It should be noted that landowners pumping their own bores, as well as the interference effect from other landholders pumped bores can significantly affect temporary standing water levels in a bore, without any influence from mining or subsidence.

On this basis, if the combined monitoring of the outlined private bores indicates a sustained drawdown of **greater than 2 m over a 2 month period** in a private bore, or, if a landowner reports a lack of groundwater availability in a bore that cannot be accessed internally, then the cause of the exceedance will be investigated to assess whether the >2 m drawdown or lack of supply is due to:

- lack of rainfall recharge, using comparison to the cumulative sum of daily rainfall;
- operation of landowner bores either within or outside an affected bores property;
- subsidence; or
- any or all of the above.

The 2 m drawdown trigger level has been derived through extrapolation of similar mining subsidence related effects in similar mining layouts and geomorphological areas in NSW and to be consistent with the minimal impact considerations of the NSW Aquifer Interference Policy.

## 8.3 Private Bore Groundwater Quality

If a landowner reports an increase in iron hydroxide precipitation or water salinity, as an initial default, the ANZECC 2000 irrigation and livestock guidelines shown in **Table 11** will be used as trigger levels to assess bore water quality.

As no bores are used for drinking water in the GwMP, drinking water quality criteria and triggers are not specified.

**TABLE 11 Groundwater Chemistry Criteria (mg/L)**

	pH	TDS	Hardness as CaCO <sub>3</sub>	Cu	Pb	Zn	Ni	Fe	Mn	As	Cd
<b>Irrigation</b>	6 - 8.5	-	>60-350	5	5	5	2	10	10	2.0	0.05
<b>Livestock</b>	-	<4000/5000	-	1/0.4	0.1	20	1	-	-	0.5	0.01

NOTE: all metals values are for filtered metals;

irrigation criteria for short term trigger values (< 20 years);

livestock criteria for beef / sheep.

## 9. POTENTIAL GROUNDWATER AMELIORATIVE ACTIONS

### 9.1 Private Bore Yield

Although it is not anticipated due to the separation distance from the bores to the proposed subsidence area, should the accessibility, available drawdown or yield of a bore be impacted due to subsidence, Chain Valley Colliery is required to provide an alternative water supply until the bore recovers.

If the level does not sufficiently recover and the effect is due to subsidence rather than regional climatic or anthropogenic factors, repairs or maintenance to a bore can be undertaken after maximum subsidence has developed. At this time the pump intake can be lowered, the bore extended to a greater depth or a new bore can be established.

With these mitigation measures in place it is unlikely that water supply to properties will be significantly impacted by the proposed mining.

In the event of a monitored or reported adverse impacts on the yield or saturated thickness of a private registered bore, the cause will be investigated.

If a groundwater level drop of over 2 m for a period of over 2 months is recorded, and the reduction in bore yield is a consequence of subsidence, the mine will enter into negotiations with the affected landowners and Subsidence Advisory NSW with the intent of formulating an agreement which provides for one, or a combination of:

- re-establishment of saturated thickness in the affected bore(s) through bore deepening;
- establishment of additional bores to provide a yield at least equivalent to the affected bore prior to mining;
- provision of access to alternative sources of water; and/or
- compensation to reflect increased water extraction costs, e.g. due to lowering pumps or installation of additional or alternative pumping equipment.

### 9.2 Private Bore Groundwater Quality

In the event of an adverse change in groundwater quality to a private bore, particularly in regard to salinity and / or iron levels, the mine will implement an investigation to determine if the cause is due to subsidence.

Although it is not anticipated due to the separation distance from the bores to the proposed subsidence area, if subsidence cracking has caused a notable increase in iron hydroxide precipitates or the landowner reports an adverse change in salinity, and that change exceeds the trigger levels, the mine will enter into negotiations with the affected landowner with the intent of formulating an agreement which provides for one, or a combination of:

- re-establishment of the water supply from a new bore to provide water equivalent to the pre mining status of the bore (on the basis that the landholder has allowed for pre-mining status of the bore to be established);
- provide access to an alternative source of water, or;
- compensate the bore owner to reflect the economic costs incurred due to the subsidence effects on the water quality.

## 10. CONTINGENCIES

In the event that the proposed monitoring indicates that a trigger has been reached or is being approached, DC will commission a hydrogeologist or hydrologist to review the data, with the outcomes of that review, including any recommendations, being subject to consultation with DPIE.

A trigger of pH or electrical conductivity would initially lead to an increase in the analytes monitored and/or frequency of sampling to confirm the magnitude and extent of the change in groundwater chemistry and verify the change is a consequence of mining.

Should the standing water level trigger be achieved in any bore, the mine staff shall notify the affected landowner(s) and, if it is the hydrogeologist's opinion that the reduction is a consequence of mining, mitigation measures identified in previous sections will be initiated.

An independent authority may also be used where a dispute arises as to the cause of the change, given that groundwater supply and quality can be affected by non-mining related factors such as bore siltation, aquifer depletion by adjoining mining operations, agricultural users, bacterial infection, fertilizer contamination etc.

## 11. AUDIT AND REVIEW

This document shall be reviewed, and if necessary revised, within 3 months of the following:

- the submission of an Annual Environmental Management Report (AEMR);
- the submission of an incident report;
- the submission of an independent environmental audit; and
- following any modification to the project approval.

Other factors that may require a review of the GwMP are:

- observation of greater impacts on surface features due to mine subsidence than was previously expected;
- observation of fewer impacts or no impacts on surface features due to mine subsidence than was previously expected; and/or
- observation of significant variation between observed and predicted subsidence.

Internal and external audits of this document will be carried out as described below. If possible, audits shall be objective and be conducted by a person or organisation independent of the document being audited.

Audits shall be carried out by personnel who have the necessary qualifications and experience to make an objective assessment of the issues. The extent of the audit, although pre-determined may be extended if a potentially serious deviation from this document is detected.

Any audit non-conformances and/or improvement opportunities will have corrective and preventative actions implemented to avoid recurrence, these actions will be loaded into the site Incident Database to ensure the actions are assigned to the relevant people and completed.

### 11.1 Internal Audits

Internal audits of this document and all other Environmental Management System documents are to be undertaken every three years. Improvements from the audit are to be incorporated in the site action database to ensure the actions are assigned to the relevant people and completed.

## 11.2 External Audits

External audits will be conducted utilising external specialists and will consider the document and related documents. External auditors shall be determined based on skills and experience and upon what is to be accomplished. External audits will be periodically at a frequency determined by the site General Manager, or in response to significant environmental incidents for which a systems failure has been determined as a contributor to the incident.

An Independent Environmental Audit (IEA) will be undertaken every three years, or as otherwise required by the Department of Planning, Industry and Environment (DPIE.) the audit will be conducted by an audit team whose appointment has been endorsed by the Secretary of DPIE.

Any actions arising from external audits will be loaded into the site actions database to ensure the actions are assigned to the relevant people and completed.

## 12. RECORDS

Generally, the site Environment and Community Coordinator will maintain all EMS records, which are not of a confidential nature. Records that are maintained include:

- monitoring data and equipment calibration;
- environmental inspections and auditing results;
- environmental incident reports;
- complaint register; and
- licenses and permits.

All records are stored so that they are legible, readily retrievable and protected against damage, deterioration and loss. Records are maintained for a minimum of 4 years.

## 13. RESPONSIBILITIES AND ACCOUNTABILITIES

### 13.1 General Manager

- Ensure that the requisite personnel and equipment are provided to enable this plan to be implemented effectively

### 13.2 Environment and Community Coordinator

- authorise the Plan and any amendments thereto;
- ensure this plan is reviewed should any changes to the mine plan or if levels of subsidence are greater than predicted. Notify the relevant authorities of any triggers being exceeded;
- reporting in the AEMR;
- ensure that inspections are undertaken in accordance with the schedule;
- ensure that persons conducting the inspection are appropriately trained, understand their obligations and the specific requirements of this plan;
- review and assess monitoring results and inspection checklists;
- promptly notify the General Manager of any identified environmental issue.

### 13.3 Hydrogeologist / Hydrologist

- assist in compiling and/or reviewing the monitoring to the standard and frequency as outlined in this plan; and
- promptly notify the Environment and Community Coordinator of any identified environmental issue.

## 14. TRAINING

All personnel who conduct inspections will be trained in the requirements of the plan.

Training will be conducted on maintaining and downloading monitoring equipment, operation of the field testing equipment and sampling procedure for laboratory analysis identification of the various subsidence impacts detailed in this plan.

## 15. REPORTING

### 15.1 Annual Environmental Management Report

An Annual Environmental Management Report (AEMR) will be submitted to DPIE each year. As part of the AEMR the groundwater section will include;

- groundwater related activities, and the level of compliance with the GwMP;
- all groundwater monitoring volumes and rates taken by the works;
- the volume groundwater extracted from the works that was discharged via the Licensed Discharge Point;
- all groundwater extraction data;
- the extent of groundwater depressurisation and any groundwater salinity impacts compared with predictions in the Environment Assessment;
- interpretation of the data, discussion of trends and their implications;
- an overall comparison of groundwater performance with predictions for the life of the mine provided in the Environmental Assessment; and
- an outline of proposed adaptive or remediation actions if required.

Notification of the groundwater monitoring results and interpretations will be reported within the required annual period to outline the natural trends and any impacts from mining on the groundwater system.

**16. REFERENCES**

- AECOM, 2011A. Groundwater Impact Assessment, Chain Valley Colliery Continuation of Mining
- AECOM, 2011B Mine Water Balance, Chain Valley Colliery Continuation of Mining
- AGE Consultants, 2006 Mannering Colliery Continuation of Mining, Environmental Assessment, Groundwater.
- ANZECC & ARMCANZ 2000 National Water Quality Management Strategy. Australian and New Zealand Guidelines For Fresh and Marine Water Quality, Vol. 1
- DIPNR, 2005 Management of Stream / Aquifer Systems in Coal Mining Developments
- Ditton Geotechnical Services, 2013 Subsidence Impact Assessment for the Chain Valley Colliery Mining Extension 1 Project
- Forster I.R., 1995 Impact of Underground Mining on the Hydrogeological Regime, Central Coast NSW. From Engineering Geology of the Newcastle Region
- Forster I., and Enever J., 1992 Hydrogeological Response of Overburden Strata to Underground Mining – Central Coast, New South Wales, Office of Energy.
- GeoTerra, 2013 Chain Valley Colliery Mining Extension 1 Groundwater Assessment, Report LDO2-R1D
- GSS Environmental, 2013 Chain Valley Colliery Mining Extension 1 Project – Surface Water Assessment
- HLA-Envirosciences, 2002 Mandalong Mine Groundwater Study Stage 1 Preliminary Review. November.
- Li, G., Forster, I., Fellowes, M., Myers, A., 2006 A Case Study on Longwall Mining under the Tidal Waters of Lake Macquarie
- Mine Subsidence Engineering Consultants, 2018 Miniwalls S2 and S3. Subsidence predictions and Impact Assessments for the Natural and Built Features due to the Extraction of the proposed Miniwalls S2 and S3 in Support of the Extraction Plan
- Peabody LakeCoal Pty Ltd, 2008 Annual Environmental Management Report, Chain Valley Colliery, Year Ending 30 June 2008
- Peabody LakeCoal Pty Ltd, 2009 Annual Environmental Management Report, Chain Valley Colliery, Year Ending 30 June 2009
- Strata<sup>2</sup>, 2018 Geotechnical Aspects of S2 and S3 Panel Design
- Strata<sup>2</sup>, 2019 Lake Coal Chain Valley Colliery, S4 Panel: Geotechnical Environment, Subsidence Estimates and Impacts
- Strata<sup>2</sup>, 2020 Lake Coal Chain Valley Colliery, S5 Panel: Geotechnical Environment, Subsidence Estimates and Impacts

## DISCLAIMER

This report was prepared in accordance with the scope of services set out in the contract between GeoTerra Pty Ltd (GeoTerra) and the client, or where no contract has been finalised, the proposal agreed to by the client. To the best of our knowledge the report presented herein accurately reflects the client's intentions when it was printed. However, the application of conditions of approval or impacts of unanticipated future events could modify the outcomes described in this document.

The findings contained in this report are the result of discrete / specific methodologies used in accordance with normal practices and standards. To the best of our knowledge, they represent a reasonable interpretation of the general condition of the site / sites in question. Under no circumstances, however, can it be considered that these findings represent the actual state of the site / sites at all points. Should information become available regarding conditions at the site, GeoTerra reserve the right to review the report in the context of the additional information.

In preparing this report, GeoTerra has relied upon certain verbal information and documentation provided by the client and / or third parties. GeoTerra did not attempt to independently verify the accuracy or completeness of that information. To the extent that the conclusions and recommendations in this report are based in whole or in part on such information, they are contingent on its validity. GeoTerra assume no responsibility for any consequences arising from any information or condition that was concealed, withheld, misrepresented, or otherwise not fully disclosed or available to GeoTerra.

Interpretations and recommendations provided in this report are opinions provided for our Client's sole use in accordance with the specified brief. As such they do not necessarily address all aspects of water, soil or rock conditions on the subject site. The responsibility of GeoTerra is solely to its client and it is not intended that this report be relied upon by any third party, who should make their own enquiries.

The advice herein relates only to this project and all results, conclusions and recommendations made should be reviewed by a competent and experienced person with experience in environmental and / or hydrological investigations before being used for any other purpose. The client should rely on its own knowledge and experience of local conditions in applying the interpretations contained herein.

To the extent permitted by law, GeoTerra, excludes all warranties and representations relating to the report. Nothing in these terms will exclude, restrict or modify any condition, warranty, right or remedy implied or imposed by any statute or regulation to the extent that it cannot be lawfully excluded, restricted or modified. If any condition or warranty is implied into this license under a statute or regulation and cannot be excluded, the liability of GeoTerra for a breach of the condition or warranty will be limited to the supply of the service again.

This report shall not be reproduced either wholly or in part without the prior written consent of GeoTerra.

## Appendix 2: Consultation

### Department of Planning and Environment



Our ref: SSD-5465-PA-103

Your ref: <Enter Client Reference>

Mr Lachlan McWha  
Environmental Compliance Coordinator  
Great Southern Energy Pty Ltd  
PO Box 7115  
MANNERING PARK NSW 2259

22 December 2022

---

**Subject: Chain Valley Extension Project (SSD-5465) Water Management Plan**

Dear Mr McWha

I refer to the Water Management Plan submitted in accordance with condition 18 of Schedule 3 of the conditions of consent for the Chain Valley Extension Project (SSD-5465).

The Department has reviewed the document and is satisfied that it has been appropriately updated in accordance with the relevant requirements of the conditions of consent.

Accordingly, the Secretary has approved the Water Management Plan (Revision 6, dated November 2022). Please ensure that the approved plan is placed on the project website at the earliest convenience.

If you wish to discuss this matter further, please contact James McDonough on (02) 9585 6313 or [james.mcdonough@dpie.nsw.gov.au](mailto:james.mcdonough@dpie.nsw.gov.au).

Yours sincerely,

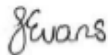

Jessie Evans  
Director, Resource Assessments  
Energy, Resources and Industry  
as nominee of the Secretary

Review Date	Next Review Date	Revision No	Document Owner	Page
16/01/2024	16/01/2027	7	Environmental Compliance and Approvals Coordinator	Page 47 of 75



TITLE Water Management Plan  
DOC ID ENV 00002– Water Management Plan  
SITE Delta Coal

DCCEEW Water Group



Department of Climate Change, Energy, the Environment and Water

Our ref: OUT24/1722

Lachlan McWha

Email: [lmcwha@deltacoal.com.au](mailto:lmcwha@deltacoal.com.au)

7 February 2024

---

Subject: Chain Valley Extension Project (SSD-5465) Water Management Plan Revision 7

Dear Lachlan McWha,

I refer to your request for advice sent on 16 January 2024 to the Department of Climate Change, Energy, the Environment and Water (DCCEEW) Water Group about the above matter.

DCCEEW Water Group has reviewed the Water Management Plan and has recommendations regarding water take and licensing. Please see **Attachment A** for more detail.

Should you have any further queries in relation to this submission please do not hesitate to contact DCCEEW Water Assessments [water.assessments@dpi.nsw.gov.au](mailto:water.assessments@dpi.nsw.gov.au).

Yours sincerely,

Rob Brownbill  
Manager, Assessments, Knowledge Division  
Department of Climate Change, Energy, the Environment and Water

---

4 Parramatta Square, 12 Darcy Street, Parramatta NSW 2150  
Locked Bag 5022, Parramatta NSW 2124

[www.dpie.nsw.gov.au](http://www.dpie.nsw.gov.au)

Review Date	Next Review Date	Revision No	Document Owner	Page
16/01/2024	16/01/2027	7	Environmental Compliance and Approvals Coordinator	Page 48 of 75

**DOCUMENT UNCONTROLLED WHEN PRINTED**



## Attachment A

### Detailed advice regarding the Chain Valley Extension Project (SSD-5465) Water Management Plan Revision 7

---

#### 1.0 Water take and licensing

---

##### 1.1 Recommendation – pre-approval

Include a summary of maximum predicted groundwater take currently and ongoing to demonstrate sufficient entitlement is held.

##### 1.2 Explanation

Groundwater take for aquifer interference activities is measured as inflows into the works. Estimates of inflows into any works which will intercept groundwater during mining operation and post closure must be included and compared to entitlement held. The proponent provides a maximum pump limit of 10.5ML/day as a surrogate for estimating inflows but notes that groundwater continues to fill the sumps when the pumps are not operating. A full estimate of groundwater take may not be accounted for if inflows occur after the 10.5ML/day is removed, hence water take will potentially be higher than estimated by pumped volume.

**End Attachment A**

---

Review Date	Next Review Date	Revision No	Document Owner	Page
16/01/2024	16/01/2027	7	Environmental Compliance and Approvals Coordinator	Page 49 of 75

**DOCUMENT UNCONTROLLED WHEN PRINTED**



TITLE Water Management Plan  
DOC ID ENV 00002– Water Management Plan  
SITE Delta Coal



Contact: Jane Curran  
Email: [jane.curran@nrar.nsw.gov.au](mailto:jane.curran@nrar.nsw.gov.au)

Chris Armit  
PO Box 7115  
Manning Park NSW 2259

Our ref: DOC21/78777, V15/3875-3#2

email: [CArmit@deltacoal.com.au](mailto:CArmit@deltacoal.com.au)

Dear Chris,

15 April 2021

**Re: Manning Colliery (PA 06\_0311), Chain Valley Colliery (SSD-5465) Water Management Plan**

Thank you for giving the Department of Planning, Industry and Environment – Water (DPIE-Water) the opportunity to review Manning Colliery (PA 06\_0311), Chain Valley Colliery (SSD-5465) Water Management Plan.

The Department of Planning, Industry and Environment recommends the following.

**Not required prior to approval**

1. Timeframes should be included in the WMP for the actionable responses in the Trigger Action Response Plans (TARPs).

Should you have any further queries in relation to this submission please do not hesitate to contact the Natural Resources Access Regulator's Service Support Team at [nrar.servicedesk@dpi.nsw.gov.au](mailto:nrar.servicedesk@dpi.nsw.gov.au).

Yours sincerely

**Alison Collaros**  
**Licensing and Approvals Manager (East)**  
**Natural Resources Access Regulator**  
**Department of Planning, Industry and Environment**

Review Date	Next Review Date	Revision No	Document Owner	Page
16/01/2024	16/01/2027	7	Environmental Compliance and Approvals Coordinator	Page 50 of 75

**DOCUMENT UNCONTROLLED WHEN PRINTED**

NSW EPA Consultation



Your ref: SSD-5465-PA-130  
Our ref: DOC24/31398-3

Mr Lachlan McWha  
Environmental Compliance & Approvals Coordinator  
Chain Valley Colliery  
Construction Road  
CHAIN VALLEY BAY NSW 2259

By email: Major Projects Portal  
cc: lmcwha@deltacoal.com.au

19 January 2024

Dear Mr McWha

**No Comment – Chain Valley Colliery – Post Approval Consultation for Site Water Management Plan**

I refer to your request received via the Major Projects Portal on 16 January 2024 for input from the NSW Environment Protection Authority (EPA) on the Post Approval Consultation for the Chain Valley Colliery Site Water Management Plan (the SWMP).

The EPA understands that the SWMP was prepared to satisfy Schedule 3, Condition 21 of Development Consent SSD-5465.

The EPA's role as a regulatory authority is to set environmental objectives rather than being involved in the development of strategies to achieve these objectives. The EPA encourages licensees and/or proponents to develop management plans as tools to ensure environmental impacts from approved activities are minimised as far as practicable.

The EPA has reviewed the SWMP and with consideration to the above, has no specific comments to make on its content. The EPA considers that the SWMP is broadly consistent with the current requirements of Environment Protection Licence 1770.

If you have any questions about this matter, please contact Phil Koenig on (02) 9995 5940.

Yours sincerely



**REBECCA AKHURST**  
Unit Head - Operations

Phone 131 555  
Phone 02 9995 5555  
(from outside NSW)

TTY 133 677, then  
ask for 131 155

Locked Bag 5022  
PARRAMATTA  
NSW 2124

6&8 Parramatta  
Square 10 Darcy  
Street  
PARRAMATTA NSW  
2150

info@epa.nsw.gov.au  
www.epa.nsw.gov.au  
ABN 43 692 285 758

Review Date	Next Review Date	Revision No	Document Owner	Page
16/01/2024	16/01/2027	7	Environmental Compliance and Approvals Coordinator	Page 51 of 75

**DOCUMENT UNCONTROLLED WHEN PRINTED**

### Appendix 3: Development Consent and EPL Summary

#### Chain Valley Colliery Development Consent SSD-5465 Summary

This WMP has been prepared in accordance to Schedule 3, Condition 21 of SSD-5465, which states the requirements of the WMP and what it must address. **Table A1** outlines the requirements of the WMP and where this document addresses these requirements.

**Table A1: Requirements from Chain Valley Colliery Development consent SSD-5465**

Condition No.	Requirement	Relevant section of this document
	<b>Schedule 2 Administrative Conditions</b>	
22	<p><b>EVIDENCE OF CONSULTATION</b></p> <p>22. Where conditions of this consent require consultation with an identified party, the Applicant must:</p> <ul style="list-style-type: none"> <li>(a) consult with the relevant party prior to submitting the subject document;</li> <li>(b) provide details of the consultation undertaken including: <ul style="list-style-type: none"> <li>i. the outcome of that consultation, matters resolved and unresolved; and</li> <li>ii. details of any disagreement remaining between the party consulted and the Applicant and how the Applicant has addressed the matters not resolved.</li> </ul> </li> </ul>	<p><b>Section 1.4</b></p> <p><b>Appendix 2</b></p>
23	<p><b>STAGING, COMBINING AND UPDATING STRATEGIES, PLANS OR PROGRAMS</b></p> <p>23. With the approval of the Planning Secretary, the Applicant may:</p> <ul style="list-style-type: none"> <li>(a) prepare and submit any strategy, plan or program required by this consent on a staged basis (if a clear description is provided as to the specific stage and scope of the development to which the strategy, plan or program applies, the relationship of the stage to any future stages and the trigger for updating the strategy, plan or program);</li> <li>(b) combine any strategy, plan or program required by this consent (if a clear relationship is demonstrated between the strategies, plans or programs that are proposed to be combined);</li> <li>(c) update any strategy, plan or program required by this consent (to ensure the strategies, plans and programs required under this consent are updated on a regular basis and incorporate additional measures or amendments to improve the environmental performance of the development); and</li> <li>(d) combine any strategy, plan or program required by this consent with any similar strategy, plan or program required by an adjoining mining consent or approval, in common ownership or management.</li> </ul>	<p><b>Section 8</b></p>
	<b>Schedule 3 Specific Environmental Conditions</b>	
18	<p><i>The Applicant must prepare and implement a Water Management Plan for the surface facilities sites to the satisfaction of the Planning Secretary.</i></p> <p><i>This plan must be prepared in consultation with DPIE Water and EPA, by suitably qualified and experienced persons whose appointment has been endorsed by the Planning Secretary and submitted to the Planning Secretary for approval within 6 months of the date of this consent.</i></p> <p><i>This plan must include:</i></p>	<p><b>Section 1.4</b></p>
	<p><i>(a) a comprehensive water balance for the development that includes details of:</i></p> <ul style="list-style-type: none"> <li>• <i>sources and security of water supply;</i></li> <li>• <i>water make in the underground workings;</i></li> <li>• <i>water transfers from the underground operations to the surface;</i></li> <li>• <i>water use; and</i></li> <li>• <i>any water discharges;</i></li> </ul>	<p><b>Section 3</b></p>

Review Date	Next Review Date	Revision No	Document Owner	Page
16/01/2024	16/01/2027	7	Environmental Compliance and Approvals Coordinator	Page 52 of 75

	<p>(b) management plans for the surface facilities sites, that include:</p> <ul style="list-style-type: none"> <li>• a detailed description of water management systems for each site, including: <ul style="list-style-type: none"> <li>– clean water diversion systems;</li> <li>– erosion and sediment controls; and</li> <li>– any water storages;</li> </ul> </li> <li>• measures to minimise potable water use and to reuse and recycle water;</li> <li>• measures to manage acid sulfate soils, if encountered;</li> <li>• activities that would involve ground disturbance at the site; and</li> <li>• monitoring and reporting procedures.</li> </ul>	<b>Section 4</b>
	<p>(c) a Surface Water Management Plan which:</p> <ul style="list-style-type: none"> <li>• includes baseline data on surface water flows and quality of Swindles Creek;</li> <li>• details surface water impact assessment criteria, including trigger levels for investigating any potentially adverse impacts on surface water resources or surface water quality;</li> <li>• provides a program to monitor: <ul style="list-style-type: none"> <li>– surface water discharges;</li> <li>– surface water flows and quality; and</li> <li>– channel stability;</li> </ul> </li> </ul>	<b>Section 5</b>
	<p>(d) a Ground Water Monitoring Program which includes a program to:</p> <ul style="list-style-type: none"> <li>• monitor and report groundwater inflows to underground workings;</li> <li>• predict, manage and monitor impacts to nearby groundwater bores on privately-owned land that may be impacted by the development; and</li> </ul>	<b>Appendix 1</b>
	<p>(e) a detailed review of surface water management at the site, with particular reference to the water storages within the dirty water management system, to:</p> <ul style="list-style-type: none"> <li>• determine whether the capacity, integrity, retention time and management of the dirty water storages (particularly the final Pollution Control Dam) are sufficient to ensure that water discharged from the site meets the EPL limits and surface water impact assessment criteria within the Surface Water Management Plan; and</li> <li>• propose any appropriate changes to the surface water management system.</li> </ul>	<b>Appendix 7</b>
	<p>The Applicant shall implement the approved management plan as approved from time to time by the Secretary.</p>	<b>This document</b>

Review Date	Next Review Date	Revision No	Document Owner	Page
16/01/2024	16/01/2027	7	Environmental Compliance and Approvals Coordinator	Page 53 of 75

	<i>NOTE: The Secretary may require the Applicant to implement upgrades and other changes identified under paragraph (e), in accordance with condition 4 of schedule 2.</i>	
	<b>Statement of Commitments</b>	
	<p><b>Groundwater</b></p> <p><i>In addition to the management and mitigation measures undertaken at the Colliery for groundwater as described in the WMP, the following commitments specific to the Proposal will be undertaken. Some commitments are already undertaken under the WMP. Delta Coal will:</i></p> <ul style="list-style-type: none"> <li><i>• assess whether abnormal or significant groundwater inflow changes occur in the active panels;</i></li> <li><i>• maintain the water flow monitoring appliances used to measure pumped water volumes to and from the Colliery in good working order;</i></li> <li><i>• maintain and plot records of daily total Colliery water pumping and annually communicate an interpretation of the findings within the Annual Review. A copy of the Annual Review will be supplied to DPI Water;</i></li> <li><i>• measure water levels and quality within private bores, where access is possible, in relevant areas to assess if any adverse effects occur due to subsidence from the Proposal; and</i></li> <li><i>• develop groundwater assessment criteria and triggers, response protocols and contingency measures.</i></li> </ul>	<b>GwMP in Appendix 1</b>
	<i>Although it is not anticipated that private bore yields would be impacted due to subsidence, should such a situation arise, Delta Coal would provide an alternative water supply until the impacted bore recovers.</i>	<b>GwMP in Appendix 1</b>
	<p><i>Any monitored or reported adverse impacts on the yield, saturated thickness or quality of a private registered bore will be investigated by Delta Coal. In the event of a groundwater level drop of over 2 m for a period of two months or more, a notable increase in iron hydroxide, or an adverse change in salinity as a consequence of subsidence, Delta Coal will enter into negotiations with the affected landowners and the Mine Subsidence Board with the intent of formulating an agreement which provides for one, or a combination of:</i></p> <ul style="list-style-type: none"> <li><i>• re-establishment of saturated thickness in the affected bore(s) through bore deepening;</i></li> <li><i>• establishment of additional bores to provide a yield at least equivalent to the affected bore prior to mining;</i></li> <li><i>• provision of access to alternative sources of water; and/or</i></li> </ul>	<b>GwMP in Appendix 1</b>

Review Date	Next Review Date	Revision No	Document Owner	Page
16/01/2024	16/01/2027	7	Environmental Compliance and Approvals Coordinator	Page 54 of 75

	<ul style="list-style-type: none"> <li>• compensation to reflect increased water extraction costs (e.g., due to lowering pumps or installation of additional or alternative pumping equipment).</li> </ul>	
	<p><b>Surface Water</b></p> <p>Management and monitoring of surface water will continue to be undertaken in accordance with the Colliery’s WMP, which will be reviewed and updated as required to include the commitments made below. Delta Coal will:</p>	<b>This document</b>
	update the WMP to include any changes as a result of the proposed modification;	<b>This document</b>
	limit the main underground pumps to a maximum pump out rate of 10.5 ML/day within 12 months of approval;	<b>Section 3.2.3</b>
	request an amendment of EPL 1770 to include a condition on the daily discharge volume limit stating that “Exceedence of the volume limit for Point 1 is permitted only if the discharge from Point 1 occurs solely as a result of rainfall at the premises exceeding 10 mm during the 24 hours immediately prior to commencement of the discharge”;	<b>Section 1.1</b>
	undertake daily measurements of discharge volumes and report publically on a monthly basis via Delta Coal’s website;	<b>Section 5.9</b>
	continue collection of baseline water quality data to aid in the development of appropriate discharge water quality trigger values;	<b>Section 5.3</b>
	engage a suitably qualified expert to conduct an assessment of the metals contained within discharge water in accordance with the ANZECC water quality guidelines and provide this assessment to the EPA by 31 December 2013;	<b>Section 2.4</b>
	investigate water saving measures to minimise the amount of potable water required from WSC for Colliery operations;	<b>Section 4.7</b>
	quantify the groundwater storage capacity in the Great Northern and Wallarah Seams;	<b>Section 4.3</b>
	continue effluent monitoring regime of receiving soils from the AWTS in accordance with the parameters and testing frequencies identified in the Colliery’s WMP. The results of this monitoring program will be reviewed by a suitably qualified expert and used to determine the appropriateness of the existing irrigation area to receive this effluent;	<b>Section 5.6</b>
	develop a program to monitor creek line channel stability and the health of riparian vegetation within Swindles Creek. Monitoring will be undertaken in accordance with Section 8.5.2 of the Surface Water Impact Assessment (EIS Appendix E) and incorporated into the Colliery’s WMP or Biodiversity Management Plan; and	<b>Section 5.4</b>

Review Date	Next Review Date	Revision No	Document Owner	Page
16/01/2024	16/01/2027	7	Environmental Compliance and Approvals Coordinator	Page 55 of 75



TITLE	Water Management Plan
DOC ID	ENV 00002– Water Management Plan
SITE	Delta Coal

	<i>record monitoring data in accordance with the Colliery’s WMP and EPL 1770. Monitoring data will be interpreted as it is received to ensure appropriate operational guidance on monitoring water quality within desired parameters. Results of water quality monitoring will be reported in the Annual Review and made available to the CCC, as well as Wyong and Lake Macquarie Councils.</i>	<b>Section 5.9</b>
--	--	--------------------

CVC operates under EPL 1770 issued by the NSW EPA under the POEO Act. The EPL has been modified a number of times, most recently on the 2 April 2019. CVC has two Licensed Discharge Points (LDP) under EPL 1770. The main discharge point is defined in the EPL as Point 1 and referred to herein as Licensed Discharge Point 1 (LDP1). Licenced Discharge Point 27 is the spillway which rarely discharges.

Relevant sections of EPL 1770 detail water related requirements and are reproduced in **Table A2** below along with identification of where the requirements are addressed in this document.

Review Date	Next Review Date	Revision No	Document Owner	Page
16/01/2024	16/01/2027	7	Environmental Compliance and Approvals Coordinator	Page 56 of 75

**DOCUMENT UNCONTROLLED WHEN PRINTED**

**Table A2: Environment Protection Licence 1770 Water Quality Requirements**

Condition No.	Requirements	Relevant section of this document												
<b>2</b>	<b>Discharges to Air and Water and Applications to Land</b>													
<b>P1</b>	<b>Location of monitoring/discharge points and areas</b>													
P1.2	The following points referred to in the table below are identified in this licence for the purposes of monitoring and/or the setting of limits for the emission of pollutants to the air from the point.	<b>Noted</b>												
P1.3	<p>The following points referred to in the table are identified in this licence for the purposes of the monitoring and/or the setting of limits for discharges of pollutants to water from the point.</p> <table border="1"> <thead> <tr> <th>EPA Identification no.</th> <th>Type of Monitoring Point</th> <th>Type of Discharge Point</th> <th>Location Description</th> </tr> </thead> <tbody> <tr> <td>1</td> <td>Discharge to waters Discharge quality and volume monitoring</td> <td>Discharge to waters Discharge quality and volume monitoring</td> <td>Discharge to waters and monitoring from final settlement pond, gravity fed discharge pipe as identified in plan titled "Delta Coal Chain Valley Colliery, Surface EPA Premises Plan, DRG No: C1S0165_2" 10 August 2021 and saved as EPA Document DOC21/691135.</td> </tr> <tr> <td>27</td> <td>Discharge to waters Discharge quality and volume monitoring</td> <td>Discharge to waters Discharge quality and volume monitoring</td> <td>Discharge to waters via dam spillway from final settlement pond adjacent to EPA Point 1 as identified in plan titled "Delta Coal Chain Valley Colliery, Surface EPA Premises Plan, DRG No: C1S0165_2" 10 August 2021 and saved as EPA Document DOC21/691135.</td> </tr> </tbody> </table>	EPA Identification no.	Type of Monitoring Point	Type of Discharge Point	Location Description	1	Discharge to waters Discharge quality and volume monitoring	Discharge to waters Discharge quality and volume monitoring	Discharge to waters and monitoring from final settlement pond, gravity fed discharge pipe as identified in plan titled "Delta Coal Chain Valley Colliery, Surface EPA Premises Plan, DRG No: C1S0165_2" 10 August 2021 and saved as EPA Document DOC21/691135.	27	Discharge to waters Discharge quality and volume monitoring	Discharge to waters Discharge quality and volume monitoring	Discharge to waters via dam spillway from final settlement pond adjacent to EPA Point 1 as identified in plan titled "Delta Coal Chain Valley Colliery, Surface EPA Premises Plan, DRG No: C1S0165_2" 10 August 2021 and saved as EPA Document DOC21/691135.	<b>Section 5</b>
EPA Identification no.	Type of Monitoring Point	Type of Discharge Point	Location Description											
1	Discharge to waters Discharge quality and volume monitoring	Discharge to waters Discharge quality and volume monitoring	Discharge to waters and monitoring from final settlement pond, gravity fed discharge pipe as identified in plan titled "Delta Coal Chain Valley Colliery, Surface EPA Premises Plan, DRG No: C1S0165_2" 10 August 2021 and saved as EPA Document DOC21/691135.											
27	Discharge to waters Discharge quality and volume monitoring	Discharge to waters Discharge quality and volume monitoring	Discharge to waters via dam spillway from final settlement pond adjacent to EPA Point 1 as identified in plan titled "Delta Coal Chain Valley Colliery, Surface EPA Premises Plan, DRG No: C1S0165_2" 10 August 2021 and saved as EPA Document DOC21/691135.											
<b>3</b>	<b>Limit Conditions</b>													
<b>L1</b>	<b>Pollution of Waters</b>													
L1.1	Except as may be expressly provided in any other condition of this licence, the licensee must comply with section 120 of the Protection of the Environment Operations Act 1997.	<b>Section 2</b>												
<b>L2</b>	<b>Concentration Limits</b>													
L2.1	For each monitoring/discharge point or utilisation area specified in the table\ below (by a point number), the concentration of a pollutant discharged at that point, or applied to that area, must not exceed the concentration limits specified for that pollutant in the table.	<b>Section 5</b>												
L2.2	Where a pH quality limit is specified in the table, the specified percentage of samples must be within the specified ranges.	<b>Section 5</b>												
L2.3	To avoid any doubt, this condition does not authorise the pollution of waters by any pollutant other than those specified in the table\.	<b>Noted</b>												

Review Date	Next Review Date	Revision No	Document Owner	Page
16/01/2024	16/01/2027	7	Environmental Compliance and Approvals Coordinator	Page 57 of 75

L2.4	<p>Water and/or Land Concentration Limits</p> <p>POINT 1,27</p> <table border="1"> <thead> <tr> <th>Pollutant</th> <th>Units of Measure</th> <th>50 percentile concentration limit</th> <th>90 percentile concentration limit</th> <th>3DGM concentration limit</th> <th>100 percentile concentration limit</th> </tr> </thead> <tbody> <tr> <td>Faecal Coliforms</td> <td>colony forming units per 100 millilitres</td> <td></td> <td></td> <td></td> <td>200</td> </tr> <tr> <td>Oil and Grease</td> <td>milligrams per litre</td> <td></td> <td></td> <td></td> <td>10</td> </tr> <tr> <td>pH</td> <td>pH</td> <td></td> <td></td> <td></td> <td>6.5-8.5</td> </tr> <tr> <td>Total suspended solids</td> <td>milligrams per litre</td> <td></td> <td></td> <td></td> <td>50</td> </tr> </tbody> </table>	Pollutant	Units of Measure	50 percentile concentration limit	90 percentile concentration limit	3DGM concentration limit	100 percentile concentration limit	Faecal Coliforms	colony forming units per 100 millilitres				200	Oil and Grease	milligrams per litre				10	pH	pH				6.5-8.5	Total suspended solids	milligrams per litre				50	Section 5
Pollutant	Units of Measure	50 percentile concentration limit	90 percentile concentration limit	3DGM concentration limit	100 percentile concentration limit																											
Faecal Coliforms	colony forming units per 100 millilitres				200																											
Oil and Grease	milligrams per litre				10																											
pH	pH				6.5-8.5																											
Total suspended solids	milligrams per litre				50																											
L3	<b>Volume and mass limits</b>																															
L3.1	<p>For each discharge point or utilisation area specified below (by a point number), the volume/mass of:</p> <p>a) liquids discharged to water; or;</p> <p>b) solids or liquids applied to the area;</p> <p>must not exceed the volume/mass limit specified for that discharge point or area.</p> <table border="1"> <thead> <tr> <th>Point</th> <th>Unit of Measure</th> <th>Volume/Mass Limit</th> </tr> </thead> <tbody> <tr> <td>1</td> <td>kilolitres per day</td> <td>12161</td> </tr> <tr> <td>27</td> <td>kilolitres per day</td> <td>12161</td> </tr> </tbody> </table>	Point	Unit of Measure	Volume/Mass Limit	1	kilolitres per day	12161	27	kilolitres per day	12161	Section 5																					
Point	Unit of Measure	Volume/Mass Limit																														
1	kilolitres per day	12161																														
27	kilolitres per day	12161																														
L3.2	The volumetric daily discharge limit for the premises is the combined discharge measured at EPA discharge points 1 and 27 and must not exceed 12161 kilolitres per day.	Section 5																														
M2	<b>Requirement to monitor concentration of pollutants discharged</b>																															
M2.3	Water and/ or Land Monitoring Requirements	Section 5																														

Review Date	Next Review Date	Revision No	Document Owner	Page
16/01/2024	16/01/2027	7	Environmental Compliance and Approvals Coordinator	Page 58 of 75

	<p><b>POINT 1</b></p> <table border="1"> <thead> <tr> <th>Pollutant</th> <th>Units of measure</th> <th>Frequency</th> <th>Sampling Method</th> </tr> </thead> <tbody> <tr> <td>Biochemical oxygen demand</td> <td>milligrams per litre</td> <td>Once a month (min. of 4 weeks)</td> <td>Grab sample</td> </tr> <tr> <td>Enterococci</td> <td>colony forming units per 100 millilitres</td> <td>Once a month (min. of 4 weeks)</td> <td>Grab sample</td> </tr> <tr> <td>Faecal Coliforms</td> <td>colony forming units per 100 millilitres</td> <td>Once a month (min. of 4 weeks)</td> <td>Grab sample</td> </tr> <tr> <td>Oil and Grease</td> <td>milligrams per litre</td> <td>Once a month (min. of 4 weeks)</td> <td>Grab sample</td> </tr> <tr> <td>pH</td> <td>pH</td> <td>Once a month (min. of 4 weeks)</td> <td>Grab sample</td> </tr> <tr> <td>Total suspended solids</td> <td>milligrams per litre</td> <td>Once a month (min. of 4 weeks)</td> <td>Grab sample</td> </tr> </tbody> </table> <p><b>POINT 27</b></p> <table border="1"> <thead> <tr> <th>Pollutant</th> <th>Units of measure</th> <th>Frequency</th> <th>Sampling Method</th> </tr> </thead> <tbody> <tr> <td>Enterococci</td> <td>colony forming units per 100 millilitres</td> <td>Daily during any discharge</td> <td>Grab sample</td> </tr> <tr> <td>Faecal Coliforms</td> <td>colony forming units per 100 millilitres</td> <td>Daily during any discharge</td> <td>Grab sample</td> </tr> <tr> <td>Oil and Grease</td> <td>milligrams per litre</td> <td>Daily during any discharge</td> <td>Grab sample</td> </tr> <tr> <td>pH</td> <td>pH</td> <td>Daily during any discharge</td> <td>Grab sample</td> </tr> <tr> <td>Total suspended solids</td> <td>milligrams per litre</td> <td>Daily during any discharge</td> <td>Grab sample</td> </tr> </tbody> </table>	Pollutant	Units of measure	Frequency	Sampling Method	Biochemical oxygen demand	milligrams per litre	Once a month (min. of 4 weeks)	Grab sample	Enterococci	colony forming units per 100 millilitres	Once a month (min. of 4 weeks)	Grab sample	Faecal Coliforms	colony forming units per 100 millilitres	Once a month (min. of 4 weeks)	Grab sample	Oil and Grease	milligrams per litre	Once a month (min. of 4 weeks)	Grab sample	pH	pH	Once a month (min. of 4 weeks)	Grab sample	Total suspended solids	milligrams per litre	Once a month (min. of 4 weeks)	Grab sample	Pollutant	Units of measure	Frequency	Sampling Method	Enterococci	colony forming units per 100 millilitres	Daily during any discharge	Grab sample	Faecal Coliforms	colony forming units per 100 millilitres	Daily during any discharge	Grab sample	Oil and Grease	milligrams per litre	Daily during any discharge	Grab sample	pH	pH	Daily during any discharge	Grab sample	Total suspended solids	milligrams per litre	Daily during any discharge	Grab sample	
Pollutant	Units of measure	Frequency	Sampling Method																																																			
Biochemical oxygen demand	milligrams per litre	Once a month (min. of 4 weeks)	Grab sample																																																			
Enterococci	colony forming units per 100 millilitres	Once a month (min. of 4 weeks)	Grab sample																																																			
Faecal Coliforms	colony forming units per 100 millilitres	Once a month (min. of 4 weeks)	Grab sample																																																			
Oil and Grease	milligrams per litre	Once a month (min. of 4 weeks)	Grab sample																																																			
pH	pH	Once a month (min. of 4 weeks)	Grab sample																																																			
Total suspended solids	milligrams per litre	Once a month (min. of 4 weeks)	Grab sample																																																			
Pollutant	Units of measure	Frequency	Sampling Method																																																			
Enterococci	colony forming units per 100 millilitres	Daily during any discharge	Grab sample																																																			
Faecal Coliforms	colony forming units per 100 millilitres	Daily during any discharge	Grab sample																																																			
Oil and Grease	milligrams per litre	Daily during any discharge	Grab sample																																																			
pH	pH	Daily during any discharge	Grab sample																																																			
Total suspended solids	milligrams per litre	Daily during any discharge	Grab sample																																																			
M3.2	Subject to any express provision to the contrary in this licence, monitoring for the concentration of a pollutant discharged to waters or applied to a utilisation area must be done in accordance with the Approved Methods Publication unless another method has been approved by the EPA in writing before any tests are conducted.	<b>Section 5</b>																																																				
<b>M8</b>	<b>Requirement to monitor volume or mass</b>																																																					
M8.1	<p>For each discharge point or utilisation area specified below, the licensee must monitor:</p> <p>a) the volume of liquids discharged to water or applied to the area;</p> <p>b) the mass of solids applied to the area;</p> <p>c) the mass of pollutants emitted to the air;</p> <p>at the frequency and using the method and units of measure, specified below.</p> <p><b>Point 1</b></p> <table border="1"> <thead> <tr> <th>Frequency</th> <th>Unit of Measure</th> <th>Sampling Method</th> </tr> </thead> <tbody> <tr> <td>Continuous during discharge</td> <td>kilolitres per day</td> <td>In line instrumentation</td> </tr> </tbody> </table> <p><b>Point 27</b></p> <table border="1"> <thead> <tr> <th>Frequency</th> <th>Unit of Measure</th> <th>Sampling Method</th> </tr> </thead> <tbody> <tr> <td>Continuous during discharge</td> <td>kilolitres per day</td> <td>In line instrumentation</td> </tr> </tbody> </table>	Frequency	Unit of Measure	Sampling Method	Continuous during discharge	kilolitres per day	In line instrumentation	Frequency	Unit of Measure	Sampling Method	Continuous during discharge	kilolitres per day	In line instrumentation	<b>Section 5</b>																																								
Frequency	Unit of Measure	Sampling Method																																																				
Continuous during discharge	kilolitres per day	In line instrumentation																																																				
Frequency	Unit of Measure	Sampling Method																																																				
Continuous during discharge	kilolitres per day	In line instrumentation																																																				

Review Date	Next Review Date	Revision No	Document Owner	Page
16/01/2024	16/01/2027	7	Environmental Compliance and Approvals Coordinator	Page 59 of 75

<b>G2</b>	<b>Other general conditions</b>																															
G2.1	<p>Completed programs</p> <table border="1"> <thead> <tr> <th>Program</th> <th>Description</th> <th>Completed Date</th> </tr> </thead> <tbody> <tr> <td>Coal Mine Particulate Matter Control Best Practice</td> <td>Requires licensee to conduct a site specific Best Management Practice (BMP) determination to identify ways to reduce particle emissions.</td> <td>28-September-2012</td> </tr> <tr> <td>Assessment of Potential Impacts of Metals in wastewater</td> <td>The licensee must conduct an assessment of metals detected in wastewater discharges from the mine in accordance with the ANZECC water quality guidelines. To obtain a greater understanding of the type and concentration of metals discharged in mine water and entering the receiving waters. To limit the concentration of metals discharged in mine water within ANZECC guidelines.</td> <td>23-October-2013</td> </tr> <tr> <td>Air Quality Monitoring</td> <td>The licensee must evaluate best locations and install monitoring devices as defined in Project Approval MP10_0161 under the Environment Planning &amp; Assessment Act 1979.</td> <td>31-December-2013</td> </tr> <tr> <td>PRP4 - Upgrade to Clean and Dirty Water Management System</td> <td>The licensee must review and upgrade separation of the Clean and Dirty Water Management System and review and upgrade bunding.</td> <td>14-August-2015</td> </tr> <tr> <td>PRP5 - Remediation of Dam Wall and Spillway formalisation</td> <td>The licensee must design and remediate the dam wall on the final control pond and formalise a spillway to prevent dam seepage and to ensure that volumetric discharge can be monitored</td> <td>27-February-2015</td> </tr> <tr> <td>PRP 6 Upgrade to Sewage Treatment Systems</td> <td>Assessment of options for improved disinfection of effluent from STP on licenced premises.</td> <td>06-January-2015</td> </tr> <tr> <td>PRP7 Sewage Treatment System Concept Design</td> <td>Provide the EPA with a Concept Design and Timetable for Implementation of Upgrade to the Sewage Treatment System</td> <td>19-February-2016</td> </tr> <tr> <td>PRP 8 - Connection of Bathhouse Wastewater to Sewer</td> <td>Connection of Bathhouse to Central Coast Council Sewer.</td> <td>14-July-2023</td> </tr> <tr> <td>PRP 9 - Office Area Wastewater Sytem Upgrades to Best Practice</td> <td>Office area wastewater treatment system upgrade to best practice.</td> <td>27-July-2023</td> </tr> </tbody> </table>	Program	Description	Completed Date	Coal Mine Particulate Matter Control Best Practice	Requires licensee to conduct a site specific Best Management Practice (BMP) determination to identify ways to reduce particle emissions.	28-September-2012	Assessment of Potential Impacts of Metals in wastewater	The licensee must conduct an assessment of metals detected in wastewater discharges from the mine in accordance with the ANZECC water quality guidelines. To obtain a greater understanding of the type and concentration of metals discharged in mine water and entering the receiving waters. To limit the concentration of metals discharged in mine water within ANZECC guidelines.	23-October-2013	Air Quality Monitoring	The licensee must evaluate best locations and install monitoring devices as defined in Project Approval MP10_0161 under the Environment Planning & Assessment Act 1979.	31-December-2013	PRP4 - Upgrade to Clean and Dirty Water Management System	The licensee must review and upgrade separation of the Clean and Dirty Water Management System and review and upgrade bunding.	14-August-2015	PRP5 - Remediation of Dam Wall and Spillway formalisation	The licensee must design and remediate the dam wall on the final control pond and formalise a spillway to prevent dam seepage and to ensure that volumetric discharge can be monitored	27-February-2015	PRP 6 Upgrade to Sewage Treatment Systems	Assessment of options for improved disinfection of effluent from STP on licenced premises.	06-January-2015	PRP7 Sewage Treatment System Concept Design	Provide the EPA with a Concept Design and Timetable for Implementation of Upgrade to the Sewage Treatment System	19-February-2016	PRP 8 - Connection of Bathhouse Wastewater to Sewer	Connection of Bathhouse to Central Coast Council Sewer.	14-July-2023	PRP 9 - Office Area Wastewater Sytem Upgrades to Best Practice	Office area wastewater treatment system upgrade to best practice.	27-July-2023	<b>Noted</b>
Program	Description	Completed Date																														
Coal Mine Particulate Matter Control Best Practice	Requires licensee to conduct a site specific Best Management Practice (BMP) determination to identify ways to reduce particle emissions.	28-September-2012																														
Assessment of Potential Impacts of Metals in wastewater	The licensee must conduct an assessment of metals detected in wastewater discharges from the mine in accordance with the ANZECC water quality guidelines. To obtain a greater understanding of the type and concentration of metals discharged in mine water and entering the receiving waters. To limit the concentration of metals discharged in mine water within ANZECC guidelines.	23-October-2013																														
Air Quality Monitoring	The licensee must evaluate best locations and install monitoring devices as defined in Project Approval MP10_0161 under the Environment Planning & Assessment Act 1979.	31-December-2013																														
PRP4 - Upgrade to Clean and Dirty Water Management System	The licensee must review and upgrade separation of the Clean and Dirty Water Management System and review and upgrade bunding.	14-August-2015																														
PRP5 - Remediation of Dam Wall and Spillway formalisation	The licensee must design and remediate the dam wall on the final control pond and formalise a spillway to prevent dam seepage and to ensure that volumetric discharge can be monitored	27-February-2015																														
PRP 6 Upgrade to Sewage Treatment Systems	Assessment of options for improved disinfection of effluent from STP on licenced premises.	06-January-2015																														
PRP7 Sewage Treatment System Concept Design	Provide the EPA with a Concept Design and Timetable for Implementation of Upgrade to the Sewage Treatment System	19-February-2016																														
PRP 8 - Connection of Bathhouse Wastewater to Sewer	Connection of Bathhouse to Central Coast Council Sewer.	14-July-2023																														
PRP 9 - Office Area Wastewater Sytem Upgrades to Best Practice	Office area wastewater treatment system upgrade to best practice.	27-July-2023																														

Review Date	Next Review Date	Revision No	Document Owner	Page
16/01/2024	16/01/2027	7	Environmental Compliance and Approvals Coordinator	Page 60 of 75

## Appendix 4: Standard Erosion and Sediment Controls

### Land Clearing Procedures (Clearing and Topsoil Stripping)

Minimise land disturbance to avoid exposing unnecessary land to the processes related to erosion and sedimentation. This is achieved by:

- All operations are planned to ensure that only the areas which are under active excavation are cleared and that there is no damage to any trees and pasture areas outside the limits to be cleared.
- Limiting the cleared width to that required to accommodate excavation plus areas required for topsoil stockpiling.
- General vegetation clearing will not be undertaken until earthwork operations are ready to commence.
- All proposed erosion and sediment control measures are implemented in advance of, or in conjunction with, vegetation clearing and soil stripping operations.
- Prior to vegetation clearing or soil stripping operations, the stripping panel is delineated on a plan and in the field will be marked by survey pegs placed at intervals on each side of the disturbed area. Topsoil limits and the topsoil stripping depths are shown on the pegs.
- Where possible, topsoil is stripped in moist but not wet condition to reduce deterioration in topsoil quality and dust generation and only be stockpiled when no areas of reshaped overburden are available for direct placement and spreading.

### Topsoil Stockpiles

Where suitable areas are unavailable for the immediate respreading, topsoil is stockpiled to a maximum depth of three metres and subsequently applied when the areas become available. The period of the stockpiling is minimised in order to reduce the detrimental effects of the storage of any native seed in the soil and damage to the soil structure.

All stockpiles are shaped, trimmed (max batter slope 3H:1V) then ripped and immediately sown with a sterile cover crop and permanent pasture species to provide stockpile stabilisation. Sediment fence is constructed around the downslope perimeter of the stockpiles where required to provide temporary sediment control until vegetation becomes established. Surface drainage in the vicinity of the stockpiles is configured as to direct any runoff around the area so not to cause any potential erosion of the loose material.

Where topsoil is used as the growing medium, it is re-spread in the reverse sequence to its removal, so that the organic layer, containing any seed or vegetation, is returned to the surface. Re-spreading on the contour aids runoff control and increased moisture retention for subsequent plant growth. Re-spread topsoil should be levelled to achieve an even surface, avoiding a compacted or an over-smooth finish.

### Access Tracks

Access tracks are constructed in accordance with appropriate standards such as those described in *Managing Urban Stormwater: Soils and Construction Vol. C - Unsealed Roads*. Surface drainage is optimised and stabilised, thereby reducing roadside erosion and sedimentation. Appropriate control measures are constructed on all access roads with cross fall drainage at 3% either side of the road crown to be largely responsible for immediate water shed from the road surface. Techniques that could be used to provide crossfall on the track include crowing, infall and outfall

- Crowing

Review Date	Next Review Date	Revision No	Document Owner	Page
16/01/2024	16/01/2027	7	Environmental Compliance and Approvals Coordinator	Page 61 of 75

**DOCUMENT UNCONTROLLED WHEN PRINTED**

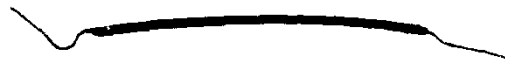

Crowning allows water to be shed on both sides

- Infall

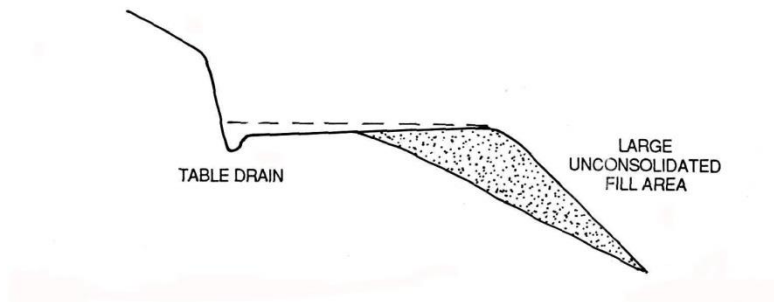

- Outfall

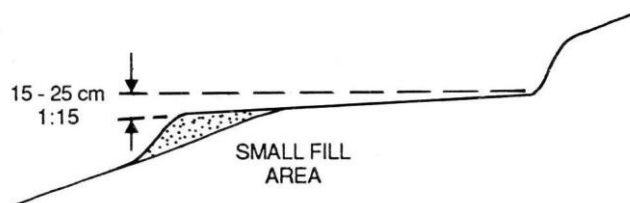

Table Drains, Mitre Drains, Culverts and Cross Drains are used where required to safely convey the water from the track surface so to prevent runoff from eroding them or adjacent land. Mitre Drain spacing should not exceed 50m even on soils with low erodibility. Cross Drains are placed every 20m to 90m depending on the road grade and soil erodibility as required. Refer to Table 5.2 of Vol2C – Unsealed Roads of the ‘Blue Book’ for more detail.

Cut and fill batters associated with service tracks are formed to a safe slope and stabilised by vegetation. Where cut batters are greater than 1.5m, stabilisation methods are applied to these areas such as laying back, revegetation and drainage. Stabilisation is assisted by spreading topsoil and/or by applying chemical or organic mulch over the exposed batter surface. Where fill batters are greater than 2:1, re-grading may be required.

Planning and construction of new tracks is undertaken in accordance with the guidelines presented Vol. 2C - Unsealed Roads of the ‘Blue Book’.

### Haul Roads

Run off from haul roads to be constructed within Chain Valley Colliery is to be contained within the mine water management system. The ultimate goal for the site is that water is not allowed to discharge from the site unless through a LDP. If the runoff from future haul road constructions are not contained within the existing mine water system, dams will be constructed to contain this water and allow it to be pumped back into the mine water management system for release through the LDPs.

During any construction of haul roads, temporary erosion and sediment controls (see **Section 1.1.8**) will be implemented. Sediment fencing will be strategically located around fill termination points as the road alignment approaches clean water drainage lines. The silt fencing will not be removed until construction of the appropriate

Review Date	Next Review Date	Revision No	Document Owner	Page
16/01/2024	16/01/2027	7	Environmental Compliance and Approvals Coordinator	Page 62 of 75

**DOCUMENT UNCONTROLLED WHEN PRINTED**

drainage and culverts are completed. Temporary sediment trapping devices may be required during construction to treat sediment-laden runoff from small areas (0.5 ha or less). Where haul roads are required to cross any watercourses, they will generally be constructed so that they cross perpendicular to the watercourse, subject to other constraints. Once constructed, long term sediment controls such as mine water sediment dams will be constructed at the outlet points of the storm water drains to contain water within the mine water management system. However haul roads at Chain Valley are currently sealed bitumen surfaces and erosion of the permanent structures may be effectively controlled by regular cleaning to prevent the accumulation of coal fines.

### Diversion Structures (Clean Water)

In order to minimise the volume of dirty and mine water to be treated, all clean run-on water is diverted where possible into clean water drainage lines to be directed off-site. This not only reduces the potential for erosion to occur on disturbed areas, but also reduces the pressure on the dirty and mine water management controls which are required to treat sediment-laden runoff to an acceptable standard for discharge. Suitably designed and constructed diversion drains are implemented where practical around the Chain Valley Colliery in accordance with 'Blue Book' standards relating to channel design. In general, the drains should be trapezoidal in shape with maximum side slopes of 1V:2H. Where peak design water velocities exceed 1.5m/s, the drains should be protected from scour using either erosion channel liners and/or geofabric with rock rip-rap armouring.

Review Date	Next Review Date	Revision No	Document Owner	Page
16/01/2024	16/01/2027	7	Environmental Compliance and Approvals Coordinator	Page 63 of 75

**DOCUMENT UNCONTROLLED WHEN PRINTED**

### Diversions Structures (Mine and Dirty Water)

Catch drains are utilised throughout the site to minimise erosion and re-direct potentially contaminated runoff into dirty water sediment dams and mine water dams. Runoff from disturbed areas, such as stockpile areas, is conveyed to these dams by catch drains and bunds.

Bunds shall be constructed similar to top soil emplacement areas, bunds shall be shaped, trimmed (max batter slope 3H:1V) then ripped and immediately sown with a cover crop and permanent pasture species to provide bund stabilization.

For runoff from rehabilitation areas, the water management structures should be appropriately designed before layout and construction. Typically the water management structures include contour banks, which are constructed at intervals down the slope of rehabilitation areas to control surface flow and minimize erosion. The effect of these is to divide long slopes into a series of short slopes with the catchment area commencing at each bank. This prevents runoff from reaching a depth of flow or velocity which would cause erosion. As the slope angle of the landform increases, the banks are spaced closer together. Bank spacing is determined based on the surrounding catchment layout and the bench spacing guide contained in Table 4.1 of *Vol2E – Mines and Quarries* of the 'Blue Book'. The banks should have a longitudinal grade of 1.2%. Where peak design water velocities exceed 1.5m/s, the drains should be protected from scour using either erosion channel liners and/or geofabric with rock rip-rap armouring.

### Control Devices

Mine water dams and mine water sediment dams (generally smaller structures) are used at Chain Valley Colliery to contain potentially contaminated 'mine' water. This water has the potential to contain elevated salinity concentrations and/or potential hydrocarbon contamination as a result of runoff from haul roads, workshop areas and areas exposed to carbonaceous material. They also function as sediment dams for sediment control but are not allowed to spill into neighbouring watercourses unless released through a LDP.

Dirty Water sediment dams are intended to catch runoff from disturbed areas that are not exposed to potential contamination of hydrocarbons or carbonaceous material. These include general construction areas and rehabilitation areas. In general dirty water sediment dams should be constructed on all disturbed areas not draining to mine water dams. The dams are constructed for the purpose of capturing sediment-laden runoff prior to off-site release. Dirty water sediment dams assist in improving water quality throughout the mine site.

The number and capacity of dams will be related to the total area of catchment, the duration of disturbance and the anticipated soil loss. The capacity of each dam is derived from the benchmark design reference for sediment control, *Managing Urban Stormwater: Soils and Construction Vol. 1 and Vol. 2E Mines and Quarries* (the Blue Book) (Landcom, 2004 and DECC, 2008). The dams are constructed to at least the recommended minimum design criteria as presented in Table 6.1 of Vol 2E Mines and Quarries of the Blue Book. For most areas, this is the 90<sup>th</sup> percentile, 5 day rainfall event for a Type F/D basin (soils that are fine textured and possibly dispersive).

The following points will be considered when selecting future sites for sediment dams:

- Each dam will be located so that runoff may easily be directed to it, without the need for extensive channel excavation or for excessive channel gradient. Channels will discharge into the dam without risk of erosion. Similarly, spillways will be designed and located so as to safely convey the maximum anticipated discharge.
- The material from which the dam is constructed will be stable and be imported from elsewhere on the mine, if necessary. Highly dispersible clays will require treatment with gypsum and/or bentonite to prevent failure.

### Temporary Erosion and Sediment Controls

Review Date	Next Review Date	Revision No	Document Owner	Page
16/01/2024	16/01/2027	7	Environmental Compliance and Approvals Coordinator	Page 64 of 75

Prior to any construction activity (including soil stripping, road construction, bulk earthworks), temporary erosion and sediment control measures are installed. The following sub-sections include temporary erosion and sediment control features that may be utilized at the site.

#### *Sediment Filter Fences*

There may, on occasion, be a disturbance area which is either not protected by existing structures or requires additional temporary protection against erosion and sedimentation. In these cases it may be suitable to install sediment filter fencing. Sediment filter fences filter run-off leaving the site, trapping sediment and allowing filtered water to pass. Sediment filter fences are constructed around the base of any areas of exposed land that are not subject to concentrated overland flow, that are not adequately protected by existing structures and that are not within the mine water management system. Sediment filter fencing is installed around the extent of the disturbance areas where sediment-laden water could potentially enter clean downstream receiving waters.

Sediment filter fences are normally placed on the contour or slightly convex to the contour. The contour on each end of the fence should be turned to create a stilling dam up slope of the fence. Where possible, a silt fence system should consist of a series of overlapping fences. Each fence should be NO longer than about 40 metres. They should not intercept large concentrated or channelised flows. The fences are constructed in accordance with the Sediment Fence Standard Drawing (SD6-8) of the 'Blue Book'. Silt fences require regular maintenance. Trapped sediments should be removed, pickets straightened, filter cloth re-secured and tightened.

#### *Sandbag Weirs*

Sandbag weirs are sometimes installed within existing swale drains or existing drainage channels, which are not able to be regularly graded. The use of these devices is limited to temporary erosion and sediment control in channels during construction or high disturbance phase mining.

The weirs are typically installed at a minimum of 40 metre intervals. As with sediment filter fences, sandbag weirs may be installed prior to any works commencing on the site in existing channels and immediately after the construction of new channels. Inspections of the sandbag weirs after rain should take place with removal of the collected sediment as required. Damaged/shifted bags should be repaired or replaced.

Review Date	Next Review Date	Revision No	Document Owner	Page
16/01/2024	16/01/2027	7	Environmental Compliance and Approvals Coordinator	Page 65 of 75

**DOCUMENT UNCONTROLLED WHEN PRINTED**

*Temporary Drains*

Runoff from areas exposed during the works is to be controlled by construction of temporary contour and diversion drains. These drains generally take the form of channels constructed across a slope, with a ridge of the lower side. They should be implemented immediately after a construction site is cleared to intercept and divert runoff from the site to nearby stable areas at non-erosive velocities. The drains should be formed with a gentle grade of approximately 1.2%

*Temporary Silt Traps*

Temporary sediment trapping devices may be required during construction to trap and filter sediment-laden runoff from small areas (0.5 ha or less) prior to discharge. They are used to trap small amounts of run-off water and filter sediment from runoff before entering the natural watercourses or to protect adjacent lands. These would typically be used at the discharge point of mitre drains and other similar devices.

Review Date	Next Review Date	Revision No	Document Owner	Page
16/01/2024	16/01/2027	7	Environmental Compliance and Approvals Coordinator	Page 66 of 75

### Appendix 5: Acid Sulfate Soil Risk Map Review

Figure 4 - DPIE Acid Sulfate Soil Risk Map

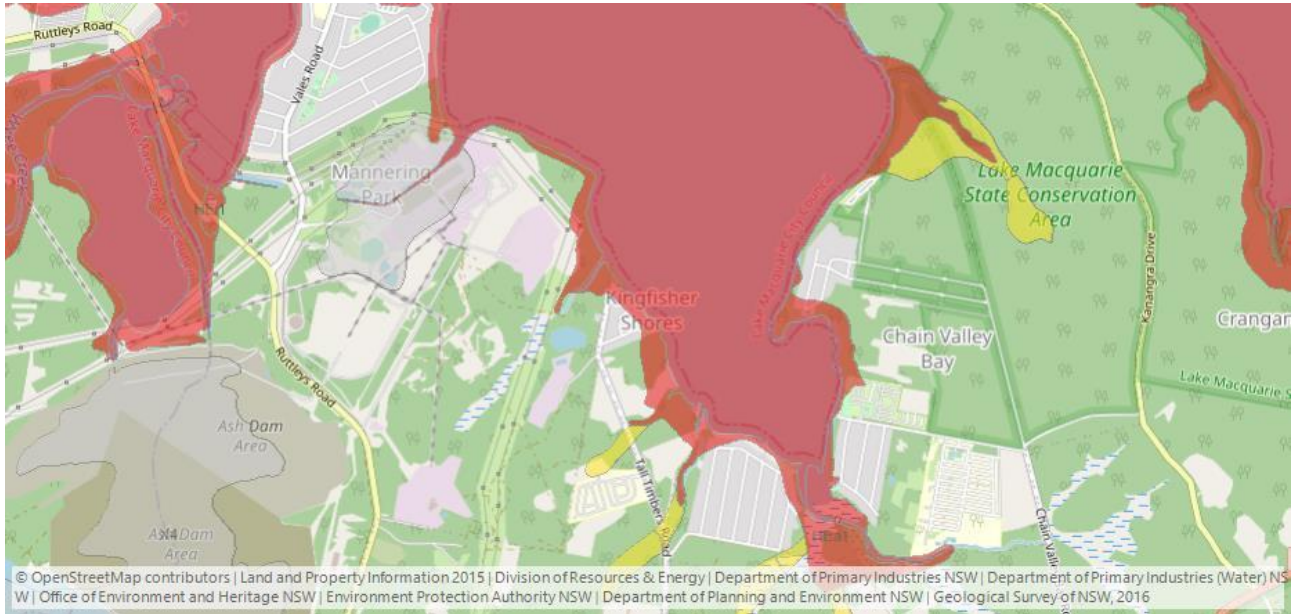

Figure 5 - ASRIS Acid Sulfate Soil Data Set (.KMZ)



Review Date	Next Review Date	Revision No	Document Owner	Page
16/01/2024	16/01/2027	7	Environmental Compliance and Approvals Coordinator	Page 67 of 75

**DOCUMENT UNCONTROLLED WHEN PRINTED**



TITLE Water Management Plan  
DOC ID ENV 00002– Water Management Plan  
SITE Delta Coal

**Appendix 6: Surface Water Assessment, GSS Environmental  
2013**

Review Date	Next Review Date	Revision No	Document Owner	Page
16/01/2024	16/01/2027	7	Environmental Compliance and Approvals Coordinator	Page 68 of 75

**DOCUMENT UNCONTROLLED WHEN PRINTED**



## LakeCoal Pty Ltd

### Chain Valley Colliery - Mining Extension 1 Project

#### *Surface Water Assessment*

March 2013

---

EMG00-008



**GSS ENVIRONMENTAL**

Environmental, Land and Project  
Management Consultants

## EXECUTIVE SUMMARY

LakeCoal is seeking an approval under Part 4, Division 4.1 of the *Environmental Planning and Assessment Act 1979* to extend the currently approved extraction area at Chain Valley Colliery to allow underground mining of the Fassifern Seam, with all secondary extraction to occur beneath Lake Macquarie. This extension would allow continuation of mining operations at the Colliery (by a further 14 years) and would increase the maximum approved rate of production from 1.2 million tonnes per annum (Mtpa) to 1.5 Mtpa ROM coal. The additional 300,000 tonnes per annum would continue to be transported back to the existing pit top facilities by conveyor where it would be processed and then transported via private roads to Vales Point Power Station.

GSS Environmental (GSSE) was commissioned by EMGA Mitchell McLennan (EMM), on behalf of LakeCoal Pty Ltd, to prepare this Surface Water Assessment (SWA) to fulfil the requirements detailed in the Director-General's Requirements relating to the preparation of an Environmental Impact Statement (EIS) to accompany the Part 4 application.

The key aspects addressed within the SWA include the identification of potential surface water impacts as a result of the proposed extension to mining; a description of the proposed mitigation and management measures to be implemented to address these potential impacts; licensing requirements; recommendations for ongoing surface water monitoring, and a detailed site water balance, including a discussion on water sources and predicted discharges from the Colliery.

A detailed 'daily time-step' water balance model was developed in GoldSim to understand water demands and flows around the pit top area of the Colliery and to demonstrate that future water management at the Colliery is sustainable. A water balance was previously undertaken for Chain Valley by AECOM in July 2011. The water balance investigation for the SWA was undertaken independently from this previous water balance with only some model inputs compared for verification. This new water balance also investigated the pit top water use in more detail to aid the future decision making process in regards to water management at the site.

The Groundwater Assessment undertaken for this Proposal predicted that the average daily water volumes pumped from the coal face would increase from approximately 7.3 ML/day to 10.5 ML/day progressively throughout the life of the Proposal, without any significant change to the quality of water extracted from the Fassifern Seam. The detailed 'daily time-step' water balance model developed in GoldSim utilised the results of the Groundwater Assessment and commitments made by LakeCoal regarding groundwater management. It indicated that a combination of underground storage utilisation, an amendment to the daily discharge volume condition within EPL 1770 and limiting the maximum daily pump rate to 10.5 ML/day is required to effectively manage water at the pit top area.

It is therefore proposed to utilise existing storage capacity in both the Wallarah and Great Northern Seams to mitigate the effects of peak groundwater inflow rates and significant rainfall events at the pit top area in order to reduce the potential for exceedance of the 12.161 ML/day LDP1 (the Colliery's single licensed discharge point) daily discharge limit. LakeCoal has indicated that these seams have a combined storage capacity of approximately 3-4 weeks (based on a 10.5 ML/day inflow) which GSSE believes is sufficient to adequately manage the predicted increase in water make expected as a result of the Proposal.

The water balance also estimated that the potable water used in the pit top area may be reduced by 32.3 kL/day (11.8 ML/year) as a result of proposed water saving measures at the Colliery, including the use of rainwater tanks and the reuse of water within the sedimentation ponds for dust suppression purposes.

As a result of the SWA, including the site water balance, a number of recommendations have been identified including the below:

- Investigate the actual available underground storage capacity due to the importance of this storage in regards to the management of water during the life of the Proposal;
- Seek an amendment to EPL 1770 to include a condition that allows exceedances of the daily discharge volume limit when 10mm of rainfall has fallen on the premises within the preceding 24 hours.
- Limit the maximum pump out rate from underground to 10.5 ML/day, within 12 months of the Proposal being approved, in order to adhere to aforementioned proposed EPL amendment. The timing of this commitment is due to the substantial upgrades involved with fully automating the pumps and having them controlled by a SCADA system.
- Collect more extensive baseline water quality data to aid the development of appropriate pollutant trigger values.
- Engage a suitably qualified expert to conduct an assessment of the metals contained within discharge water in accordance with the ANZECC water quality guidelines and issue this assessment to the EPA by the 31<sup>st</sup> December 2013.

No adverse impacts to the surrounding environment are expected as a result of the Proposal since the water make from underground is not expected to change in terms of either discharge flow rates (i.e. quantity) or water quality.

# TABLE OF CONTENTS

<b>EXECUTIVE SUMMARY .....</b>	<b>2</b>
<b>1.0 PROPOSAL DESCRIPTION.....</b>	<b>1</b>
1.1 Introduction .....	1
1.2 The Proposal .....	1
1.3 Purpose of this Report.....	2
1.3.1 <i>Scope of Surface Water Assessment</i> .....	2
1.3.2 <i>Director-General's Requirements</i> .....	2
1.4 Literature Review.....	6
<b>2.0 RELEVANT LEGISLATION, POLICY AND GUIDELINES .....</b>	<b>7</b>
2.1 Introduction .....	7
2.2 Legislation.....	7
2.2.1 <i>Water Act 1912 and Water Management Act 2000</i> .....	7
2.2.2 <i>Protection of the Environment Operations Act 1997</i> .....	7
2.2.3 <i>Environmental Planning and Assessment Act 1979</i> .....	7
2.2.4 <i>Mining Act 1992</i> .....	8
2.3 Policies and Guidelines .....	8
2.3.1 <i>ANZECC Guidelines</i> .....	8
2.3.2 <i>NSW Water Quality and River Flow Objectives</i> .....	9
2.3.3 <i>NSW State Rivers and Estuaries Policy</i> .....	12
2.3.4 <i>Environmental Guidelines: Use of Effluent by Irrigation</i> .....	12
2.3.5 <i>Managing Urban Stormwater: Soils and Construction</i> .....	13
2.3.6 <i>NSW Farm Dams Policy</i> .....	13
<b>3.0 EXISTING SURFACE WATER ENVIRONMENT .....</b>	<b>15</b>
3.1 Climate / Rainfall.....	15
3.2 Landform.....	15
3.3 Surrounding Land Uses.....	15
3.4 Soils / Geology.....	16
3.5 Existing Surface Water Quality and Assessment Criteria .....	16
3.5.1 <i>Licensed Discharge Points</i> .....	16
3.5.2 <i>Existing Surface Water Quality</i> .....	17
<b>4.0 EXISTING SURFACE WATER MANAGEMENT.....</b>	<b>19</b>
4.1 Existing Erosion and Sediment Control Structures .....	19
4.1.1 <i>Clean Water Diversion</i> .....	19
4.1.2 <i>Pit Top Catchment Areas</i> .....	19

4.1.3	<i>Sedimentation Ponds</i> .....	20
4.2	Additional Water Management .....	21
4.2.1	<i>Potable water</i> .....	21
4.2.2	<i>Groundwater</i> .....	21
4.2.3	<i>Dust Suppression</i> .....	22
4.2.4	<i>Alternative Supply</i> .....	22
4.2.5	<i>Wastewater Disposal and Management</i> .....	22
4.2.6	<i>Oil Water Separation</i> .....	22
<b>5.0</b>	<b>SITE WATER BALANCE</b> .....	<b>23</b>
5.1	Introduction .....	23
5.2	Model Representation and Accuracy.....	23
5.3	Data (Model Inputs and Outputs) .....	25
5.3.1	<i>Rainfall Runoff</i> .....	25
5.3.2	<i>Evaporation</i> .....	26
5.3.3	<i>Underground Water Extraction</i> .....	27
5.3.4	<i>Sedimentation Pond Characteristics</i> .....	28
5.3.5	<i>Loss of Water through Coal Export</i> .....	28
5.3.6	<i>Additional Data Supplied by LakeCoal</i> .....	28
5.4	Water Balance Results .....	30
5.4.1	<i>Expected Discharge from the Colliery</i> .....	30
5.4.2	<i>Potable Water Use</i> .....	31
<b>6.0</b>	<b>SURFACE WATER IMPACTS AND PROPOSED MANAGEMENT MEASURES</b> .....	<b>32</b>
6.1	Objectives .....	32
6.2	Water Discharge Quantity Management .....	32
6.2.1	<i>Pit Top Area including Pumping from Underground</i> .....	32
6.2.2	<i>Storm Surge Capacity in Sedimentation Ponds</i> .....	33
6.3	Water Quality Management.....	33
6.4	Erosion and Sediment Control Structures .....	34
6.5	Potable Water Management.....	34
<b>7.0</b>	<b>SITE WATER MANAGEMENT PLAN</b> .....	<b>36</b>
<b>8.0</b>	<b>SURFACE WATER MONITORING PROGRAM</b> .....	<b>37</b>
8.1	Introduction .....	37
8.2	Baseline Data .....	37
8.3	Surface Water Impact Assessment Criteria and Trigger Levels .....	37
8.4	Surface Water Monitoring and Frequency.....	38
8.5	Additional Operational Monitoring .....	40
8.5.1	<i>Effluent Monitoring</i> .....	40
8.5.2	<i>Stream Health Channel Flow and Riparian Vegetation Monitoring</i> .....	41

8.6 Reporting of Monitoring Data.....	41
<b>9.0 CONCLUSION .....</b>	<b>43</b>
<b>10.0 REFERENCES .....</b>	<b>45</b>

## **TABLES**

Table 1 - Summary of DGRs relevant to Surface Water Assessment.....	3
Table 2 - Key Default Trigger Values for Marine Environment 95% Protection Levels (ANZECC 2000)..	9
Table 3 – Aquatic Ecosystems Guidelines for Estuaries in Lake Macquarie and Tuggerah Lakes .....	10
Table 4 – Visual Amenity Guidelines for Estuaries in Lake Macquarie and Tuggerah Lakes .....	11
Table 5 – Secondary Contact Recreation Guidelines for Estuaries in Lake Macquarie and Tuggerah Lakes.....	11
Table 6 - Classification of Effluent for Environmental Management.....	13
Table 7 - Recommended Effluent Sampling Frequency .....	13
Table 8: Concentration Limits for LDP 1 (EPL 1770).....	16
Table 9 – Pit Top Catchment Areas, Soil Loss Parameters and Estimated Average Annual Runoff Volumes .....	26
Table 10 – Sedimentation Pond Parameters.....	28
Table 11 – Supplied and Derived Data .....	29
Table 12 – Pollutant Trigger Values for Chain Valley Colliery .....	38
Table 13 – EPL 1770 Surface Water Monitoring Locations and Frequency.....	39
Table 14 – Recommended Soil Monitoring Strategy .....	40

## **Figures**

Figure 1.1 – Regional Context
Figure 1.2 – The Site
Figure 1.3 – Preliminary Miniwall Layout
Figure 4.1 – Water Management System (Including Proposed Structures)
Figure 4.2 – Existing Water Management System Schematic
Figure 5.1 – Proposed Water Management Schematic
Figure 5.2 – Water Balance Schematic as Modelled in GoldSim
Figure 5.3 – Annual Rainfalls in Chain Valley Region
Figure 5.4 – Average Adjusted Monthly Evaporation Rates
Figure 5.5 - LDP1 Discharge Results Assuming Constant Maximum Pumping Rate from Underground
Figure 8.1 – Surface Water Monitoring Locations

## **APPENDICES**

Appendix A – Baseline Site Water Quality LDP 1
Appendix B – Water Management Plan
Appendix C – Site Water Balance

## 1.0 PROPOSAL DESCRIPTION

### 1.1 Introduction

The Chain Valley Colliery (the Colliery) is an underground coal mine located at the southern end of Lake Macquarie, approximately 60 km south of Newcastle (**Figure 1.1**). The Colliery is operated by LakeCoal Pty Ltd (LakeCoal), on behalf of the Wallarah Coal Joint Venture. Underground mining has occurred at the Colliery since 1962, with coal extraction undertaken using a combination of bord and pillar and miniwall mining methods. The Colliery has extracted coal from three seams – the Wallarah Seam, the Great Northern Seam and the Fassifern Seam, with current extraction activities restricted to the Fassifern Seam as approved under the Colliery's existing approval, MP10\_0161.

Geological features identified during mining of the approved secondary extraction area (Domains No. 1 and No. 2 – MP10\_0161) will prevent LakeCoal from recovering all of the resource approved for mining. It is currently estimated that the reserve within the approved secondary extraction area will be exhausted by late 2013. If access to further coal resources is not approved by this time, the Colliery will be forced to shut down affecting employment and the supply of coal to Vales Point Power Station and other customers. LakeCoal is therefore seeking an approval under Part 4, Division 4.1 of the *Environmental Planning and Assessment Act 1979* to extend the area of extraction and allow continuation of mining operations at the Colliery.

### 1.2 The Proposal

The Proposal comprises:

- an extension of the currently approved extraction area to allow underground mining of the Fassifern Seam within the Site, with all secondary extraction to occur beneath Lake Macquarie (see **Figure 1.2**);
- an increase to the maximum approved rate of production from 1.2 million tonnes per annum (Mtpa) to 1.5 Mtpa ROM coal. The additional 300,000 tonnes per annum will be transported via private roads to Vales Point Power Station;
- a change from the current hours for haulage of coal from the Colliery to Delta Electricity's Vales Point Power Station on private roads, i.e. from 5:30 am to 5:30 pm, Monday to Friday (excluding public holidays) to 24 hours a day, seven days a week;
- minor upgrades and modifications to surface infrastructure; and
- an extension of the approved mining period by a further 14 years, i.e. to around 2027.

The Proposal includes the consolidation of the above with all the operations and environmental activities currently approved under MP10\_0161, as modified, within a single Development Consent.

The proposed coal extraction activities are to be undertaken entirely within the Fassifern Seam and will comprise both first workings (development) and secondary extraction by miniwall mining methods. The indicative mine plan is shown on **Figure 1.3**. As is the case with the secondary extraction areas approved under MP10\_0161, the proposed secondary extraction areas are located entirely below the bed of Lake Macquarie, in areas where the depth of cover approximates 200 m. Coal would continue to be transported back to the existing pit top facilities by conveyor where it would be processed and then distributed to customers via truck in the same manner as currently approved.

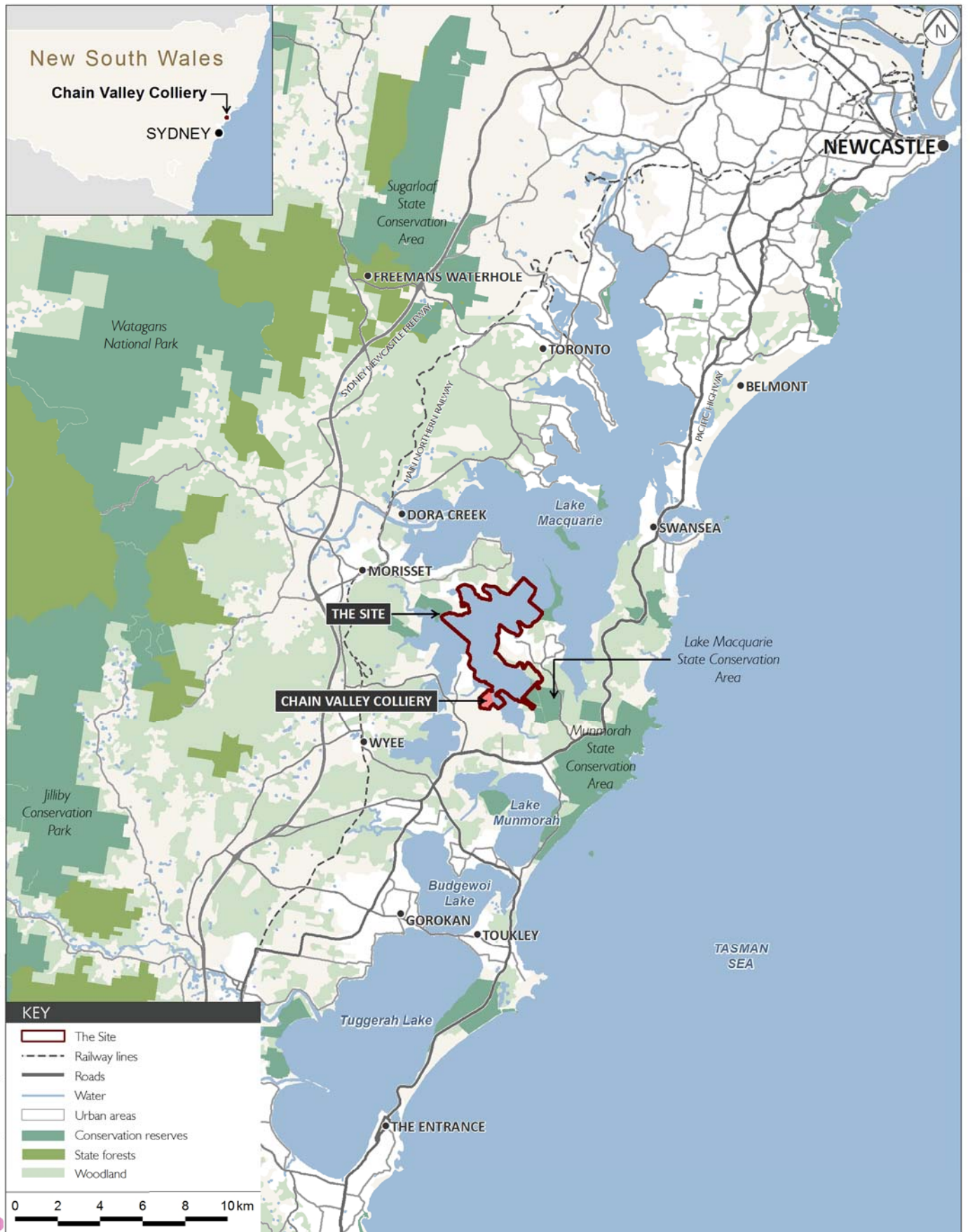

Regional context

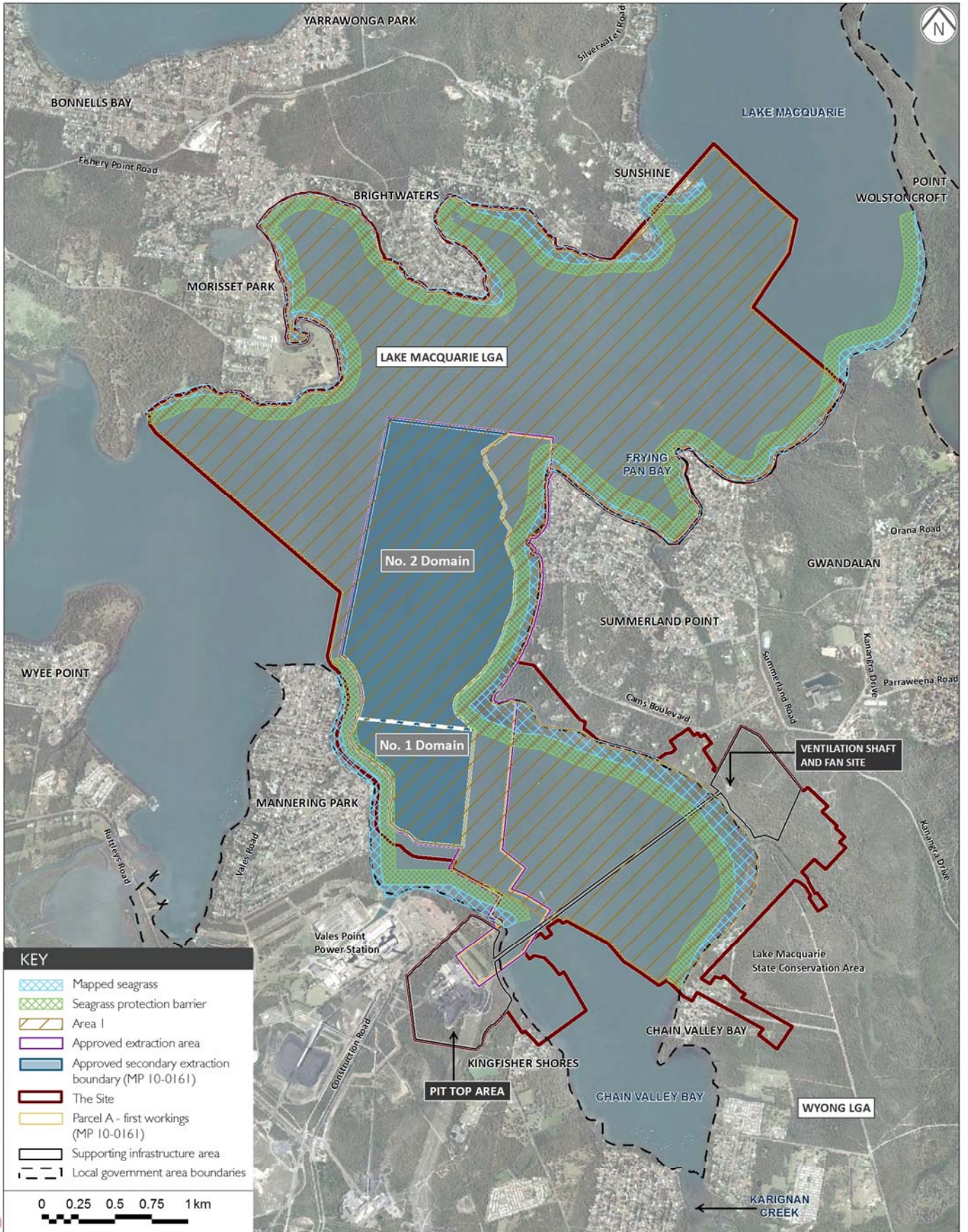

The Site

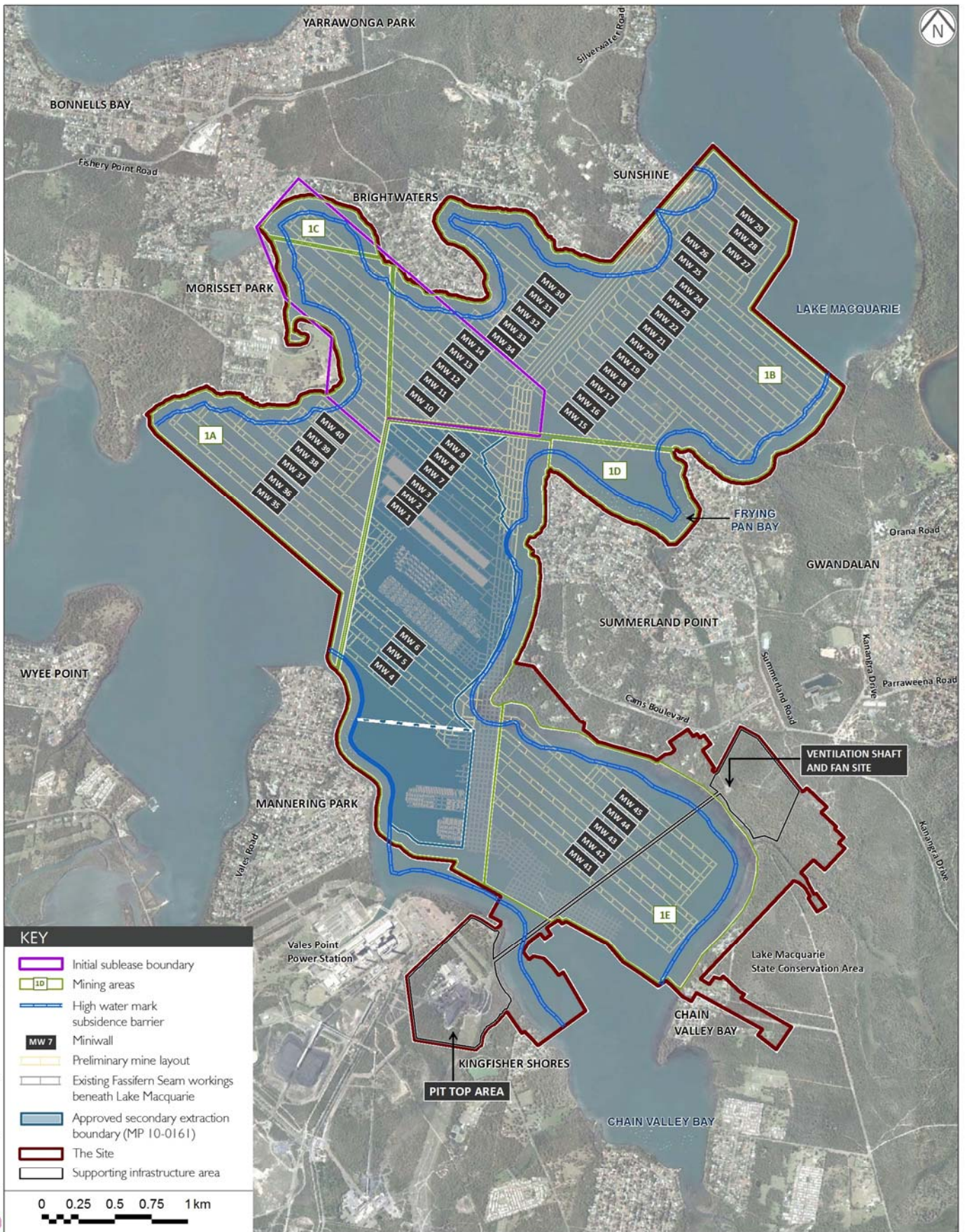

Integrated Design Solutions | 030634 Chain Valley Mine- ES F3-1 Rev K - 28 February 2013

Note: Boundaries offset for clarity

Preliminary mine layout

## 1.3 Purpose of this Report

### 1.3.1 Scope of Surface Water Assessment

LakeCoal engaged EMGA Mitchell McLennan (EMM) to prepare the Environmental Impact Statement (EIS) for the Chain Valley Colliery - Mine Extension 1 Project (the Proposal). GSS Environmental (GSSE) was subsequently engaged by EMM as a sub-consultant to undertake the Surface Water Assessment (SWA) component of the EIS.

As the proposed mining is all to be undertaken underground, the extent of this SWA is limited to the potential impacts from the management of the mine dewatering and surface operations. The primary potential surface water impacts from the Proposal comprise increased amounts of water made from the underground workings that will need to be managed to satisfy the requirements of Environmental Protection Licence (EPL) 1770 and the consequential increased discharge of water (predominantly sourced from underground) into Lake Macquarie.

The SWA:

- collates relevant data, including meteorological data (rainfall events), surface water flow regimes (water quality and quantity), catchment characteristics, surface water features, and surrounding land uses. Information has been collected from a literature review of the Colliery and NSW government records, as well as from a site inspection undertaken by GSSE personnel on 4 June 2012;
- identifies key issues, relevant assessment criteria and constraints relating to surface water;
- considers existing controls for management of surface water at the Colliery;
- recommends safeguards and mitigation measures to be implemented to ensure that potential surface water impacts are managed and appropriate criteria are met;
- presents a detailed site water balance to assist with the assessment of water security and predicted discharges;
- provides recommendations for ongoing surface water monitoring; and
- assesses the potential impacts of the Proposal on surface water flows within the pit top area (surface component of the Colliery) and the surrounding watercourses.

### 1.3.2 Director-General's Requirements

The Director-General's Requirements (DGRs) for the Proposal were provided in a letter from the Department of Planning and Infrastructure (DP&I) on 14<sup>th</sup> August 2012.

**Table 1** provides a summary of the DGRs relevant to the SWA and related environmental assessment requirements provided by other government agencies. It also indicates where the specific requirements have been addressed within this document.

**Table 1 - Summary of DGRs relevant to Surface Water Assessment**

Agency	Details of Requirements	Location addressed
Department of Planning and Infrastructure (DP&I) – DGRs	<p>The EIS must include a:</p> <ul style="list-style-type: none"> <li>• Detailed assessment of the key issues specified below, and any other significant issues identified in this risk assessment, which includes:                             <ul style="list-style-type: none"> <li>○ A description of the existing environment, using <u>sufficient baseline data</u>;</li> <li>○ An assessment of the potential impacts of all stages of the development, including any cumulative impacts, taking into consideration relevant guidelines, policies, plans and statutes; and</li> <li>○ A description of the measures that would be implemented to avoid, minimise and if necessary, offset the potential impacts of the development, including proposals for adaptive management and/or contingency plans to manage any significant risks to the environment.</li> </ul> </li> </ul> <p>The EIS must address the following specific issues:</p> <ul style="list-style-type: none"> <li>• Water Resources – including:                             <ul style="list-style-type: none"> <li>○ Detailed assessment of potential impacts on the quality and quantity of existing surface and ground water resources, including detailed modelling of potential groundwater impacts;</li> <li>○ A detailed site water balance, including a description of site water demands, water disposal methods (inclusive of volume and frequency of any water discharges), water supply infrastructure and water storage structures;</li> <li>○ An assessment of proposed water discharge quantities quality/ies against receiving water quality and, if relevant, flow objectives;</li> <li>○ Identification of any licensing requirements or other approvals under the <i>Water Act 1912</i> and/or <i>Water Management Act 2000</i>; and</li> <li>○ A detailed description of the proposed water management system (including sewage), water monitoring program and other measures to mitigate surface and groundwater impacts.</li> </ul> </li> </ul>	<p>Section 3.0</p> <p>Section 6.0</p> <p>Section 6.0</p> <p>Section 6.0</p> <p>Section 6.0</p> <p>See Groundwater Assessment Report</p> <p>Section 5.0</p> <p>Section 6.0</p> <p>Section 2.2.1</p> <p>Sections 6.0 and 8.0</p>
Wyong Shire Council	<p>Wyong Shire Council has made the following comments relevant to the Surface Water Assessment.</p> <ul style="list-style-type: none"> <li>• Details of any change to the existing settling ponds and water control facilities shall be included in the Environmental Assessment.</li> <li>• The project shall consider sustainable options in relation to the provision of new infrastructure, rainwater reuse etc.</li> <li>• Details of any change to the Colliery's current potable water use shall be included in the Mine/Water Balance.</li> </ul>	<p>Section 6.0</p> <p>Section 6.5</p> <p>Sections 5.3.6 and 5.4.2</p>

Agency	Details of Requirements	Location addressed
<p>Department of Environment, Climate Change and Water (DECCW) (now Office of Environment and Heritage)</p>	<p>DECCW requires the following information to determine the extent of environmental impacts of the proposal.</p> <p><b>Water</b></p> <p>The EA must provide sufficient information to demonstrate that the proposed development can be operated whilst complying with the <i>Protection of the Environment Operations (POEO) Act 1997</i>, in particular, the protection of water quality, including groundwater, during construction, operation and following mine closure.</p> <p>Potential impacts on water quality and quantity must be addressed, and mitigating measures proposed, for all on site water resources, all receiving waters downstream, and Lake Macquarie. The EA must assess:</p> <ul style="list-style-type: none"> <li>• Details of all proposed water discharges including locations, water volumes, water quality and under what conditions;</li> <li>• The expected water quality of all proposed discharges assessed in accordance with the Guidelines for Fresh and Marine Water Quality (ANZECC 2000);</li> <li>• DECCW requires very careful consideration of metal and salt discharges from the premises. The concentrations of metals and salinity in discharge waters should be directly compared with those in the receiving waters and Lake Macquarie using the Guidelines for Fresh and Marine Water Quality (ANZECC 2000). All impacts on receiving waters should then be assessed and mitigation measures proposed where ANZECC criteria cannot be met.</li> <li>• Quality of runoff from exposed soils, roads and coal handling areas;</li> <li>• Quality of seepage water into access pits;</li> </ul> <ul style="list-style-type: none"> <li>• Design and location of all sediment and erosion control structures;</li> <li>• Methods proposed to deal with pollutants other than sediments that may be in the water;</li> </ul> <ul style="list-style-type: none"> <li>• Spillage controls and bunding;</li> <li>• Sealing, kerbing and guttering of trafficable areas;</li> <li>• Provision of truck washing facilities capable of washing wheels and under body of vehicles leaving the premises;</li> <li>• Potential impacts on water quality and quantity for receiving waters downstream of the mine; and</li> <li>• Potential long terms impacts on Lake Macquarie.</li> </ul> <p>The methodology, data and assumptions used to design any pollution control works and assess the potential impact of the proposal on water quality, must be fully documented and justified.</p> <p>The EA must include a detailed Water Management Plan and site water balance (which includes cumulative water balance modelling and assessment for all existing mines in the vicinity and the proposed mine) incorporating the following matters:</p> <ul style="list-style-type: none"> <li>• Maximum on-site reuse of wastewater together with adequate water storages to avoid any discharge of pollutants from the premises. This must include correct installation and sizing of the wastewater collection and recycling systems;</li> <li>• Details of all measures employed to minimise all water discharges</li> </ul>	<p>Section 6.0</p> <p>Section 6.0</p> <p>Section 6.0</p> <p>Sections 3.5.2 and 6.3</p> <p>Sections 3.5.2 and 6.3</p> <p>Section 3.5.2</p> <p>See Groundwater Assessment Report</p> <p>Sections 4.1 and 6.4</p> <p>Sections 3.5.2 and 6.3</p> <p>Sections 4.1.2, 4.1.3 and 6.4</p> <p>Section 6.4.1</p> <p>Section 6.4</p> <p>Sections 6.2 and 6.3</p> <p>Sections 5.0, 6.3 and 7.0</p> <p>Appendices B and C</p> <p>Appendices B and C</p> <p>Appendices B and C</p> <p>Appendices B and C</p>

Agency	Details of Requirements	Location addressed
	<p>from the premises at all times;</p> <ul style="list-style-type: none"> <li>• Prevention of wet weather overflows of contaminated stormwater by collection and reuse or treatment of contaminated first flush stormwater;</li> <li>• Segregation of contaminated water from non-contaminated water to minimise the volume of polluted water to be dealt with;</li> <li>• Management of groundwater and surface waters; and</li> <li>• Detailed design and management of all proposed water storages.</li> </ul> <p><b>Monitoring Programs</b></p> <p>The EA should include a detailed assessment of any noise, air quality, water quality or waste monitoring required during the construction phase and on-going operation of the facility to ensure that the development achieves a satisfactory level of environmental performance. The evaluation should include a detailed description of the monitoring locations, sample analysis methods and the level of reporting proposed.</p>	<p>Appendices B and C                      Appendices B and C                      Section 8.0</p>
I&I NSW	<p><b>Environmental Management</b></p> <ul style="list-style-type: none"> <li>• LakeCoal must present in the EA the infrastructure upgrade and improvements required at the Chain Valley pit top layout and hardstand areas, coal handling and stockpiling, hydrocarbon management, waste management and water use and management.</li> </ul>	<p>Sections 6.0</p>
Lake Macquarie City Council	<p><b>Surface and Groundwater</b></p> <p>The proponent must assess the following:</p> <ul style="list-style-type: none"> <li>• The impact of the mining operation and final landform on riparian corridors and creeklines.</li> <li>• Stormwater management issues including the maintenance of pre-development peak stormwater discharges and volumes; and the management of water quality and the health of riparian corridors.</li> <li>• The necessary erosion and sediment control requirements and provide a short and long term management plan.</li> <li>• Changes to stream hydrology resulting from subsidence including impacts on downstream ecology and riparian habitats.</li> <li>• Impacts of altered stream hydrology on alluvial flows.</li> <li>• Impacts on local and regional groundwater hydrology including substantial aquifers relied upon by adjoining properties and nearby land uses.</li> <li>• Impacts on groundwater dependent ecology.</li> <li>• Quantification of any off-site impacts due to altered mine water discharges.</li> <li>• Options for mine water reuse.</li> </ul>	<p>Sections 6.2, 6.3 and 8.5.2                      Sections 4.1.2, 6.2 and 6.3                      Sections 4.1 and 6.4                      See Subsidence Assessment Report                      Section 6.2                      See Groundwater Assessment Reports                      See Groundwater Assessment Reports                      Section 6.2                      Section 6.5</p>

## 1.4 Literature Review

The following documentation was reviewed by GSSE as part of the SWA:

- Assessment of metals in Sediment from Lake Macquarie, New South Wales, Australia, using normalisation models and sediment quality guidelines (Roach 2005);
- Baseline Site Water Quality LDP 1;
- Bureau of Meteorology weather station data;
- *Contour/detail survey, settling ponds Chain Valley Colliery, Ruttleys Road, Chain Valley Bay* prepared by Pearson & Associates (2009);
- *Chain Valley Colliery - Mine Extension 1 Project, Groundwater Assessment* prepared by Geoterra (2012)
- *Chain Valley Colliery Water Management Plan, Environmental Management Plan* prepared by GSSE in 2012;
- *Environmental Assessment Chain Valley Colliery Domains 1 and 2 Continuation Project*, LakeCoal Pty Ltd prepared by AECOM (July 2011);
- *Environmental Protection Licence 1770 – Chain Valley Colliery*, Environmental Protection Authority – NSW (Dec, 2011);
- *Mine Operation Plan (2008-2015)* prepared by LakeCoal;
- *Mine Water Balance Chain Valley Continuations of Mining* prepared by AECOM (July 2011);
- Various government legislation, policy and guideline documents; and
- Various 'in-house' LakeCoal spreadsheets and records detailing coal analysis, employee shift work records, historic pump flow rates, water usage and water cart records, and water quality data.

A full list of references used for the development of this SWA is contained in **Section 10.0**.

## 2.0 RELEVANT LEGISLATION, POLICY AND GUIDELINES

### 2.1 Introduction

A number of legislative requirements, government policies and guidelines relating to surface water management are applicable to the Proposal and have been considered in this SWA. The relevant policies, guidelines and legislative requirements are summarised in **Sections 2.2 and 2.3**.

### 2.2 Legislation

The Acts considered during the development of this SWA included the following:

- *Water Act 1912 and Water Management Act 2000*;
- *Protection of the Environment Operations Act 1997*;
- *Environmental Planning and Assessment Act 1979*; and
- *Mining Act 1992*.

#### 2.2.1 Water Act 1912 and Water Management Act 2000

The *Water Act 1912* and *Water Management Act 2000* (WM Act) contain provisions for the licensing of water capture, interception and use. If any dams are proposed as part of a Proposal, consideration must be given to whether the dams need to be licensed. There are currently no new dams proposed for the site. All existing dams are for the purpose of Erosion and Sediment Control (ESC), and these are exempt from the licensing requirements.

LakeCoal is committed to obtaining all relevant licences for the continuation of their mining operations. LakeCoal has developed a water management plan inclusive of a groundwater management component, separate to the EIS process, which has been provided to the NSW Office of Water in support of a licence application for the interception and incidental groundwater take under the *Water Act 1912*. The Application for this licence was lodged on the 5<sup>th</sup> October, 2011 and is in the process of being determined.

#### 2.2.2 Protection of the Environment Operations Act 1997

The *Protection of the Environment Operations Act 1997* (POEO Act) is relevant to the Proposal as it contains requirements relating to the prevention of the pollution of waters. In this regard, the discharge of water from the Colliery's pit top area will need to be controlled to an agreed standard to reduce the potential for pollution of the receiving waters. As mentioned previously, the Colliery has an existing EPL under the *POEO Act* for the discharge of water from site. As demonstrated in this SWA, there will be no additional discharge points required as a result of the Proposal.

#### 2.2.3 Environmental Planning and Assessment Act 1979

The *Environmental Planning and Assessment Act 1979* (EP&A Act) specifies the planning approval and development consent requirements for mines and quarries. The State Environmental Planning Policy (SEPP) *Mining, petroleum production and extractive industries 2007* notes the types of mining operations permissible under the EP&A Act with and without development consent. Generally, only exploration and rehabilitation activities are permitted without consent, while mining or quarrying developments require consent.

This SEPP requires consent authorities to consider whether or not the consent should be issued subject to conditions to ensure that impacts on significant water resources, including surface water and groundwater, are either avoided or minimised as far as practicable.

Where development consent is required and the development exceeds thresholds set by the EP&A Act (as per this Proposal), the development is considered a 'designated development' and an EIS must be lodged with the application. This SWA forms part of the EIS.

## 2.2.4 Mining Act 1992

Mining and associated exploration activities must be undertaken in accordance with approvals issued under the *Mining Act 1992* (Mining Act).

There are five types of approvals issued under the Mining Act, all of which can be granted subject to conditions, including conditions for protection of the environment. The conditions often include requirements for addressing soil and water issues. For mining operations, the conditions of approval require mining to be undertaken in accordance with a mining operations plan (MOP) that has been assessed and approved by the Division of Resources and Energy within the Department of Trade and Investment, Regional Infrastructure and Services (DTIRIS). The MOP documents site activities and progress towards the required environmental and rehabilitation outcomes, including a description of the soil and water management measures to be implemented. The Chain Valley Colliery MOP covering the 2008-2015 period will be reviewed and updated as required to include the relevant aspect identified during this Proposal.

## 2.3 Policies and Guidelines

Key policies and guidelines which are relevant to the preparation of this SWA include:

- ANZECC, Australian and New Zealand Guidelines for Fresh and Marine Water Quality (the "ANZECC Guidelines"), October 2000;
- NSW Water Quality and River Flow Objectives, September 1999;
- NSW State Rivers and Estuaries Policy;
- Environmental Guidelines: Use of Effluent by Irrigation, Department of Environment and Conservation (NSW), 2004;
- Managing Urban Stormwater: Soils and Construction (the Blue Book), Volume 1 and Volume 2E – Mines and Quarries (Landcom, 2004 and Department of Environment and Climate Change (DECC), 2008; and
- NSW Farm Dams Policy.

### 2.3.1 ANZECC Guidelines

The *Australian and New Zealand Guidelines for Fresh and Marine Water Quality* (ANZECC, 2000) outline a number of default trigger values for assessing water quality. The water quality monitoring results for the downstream watercourse (Swindles Creek to the east of the pit top area shown in **Figure 4.1**) will be assessed generally in accordance with these values (refer **Section 8.3** for more information relating to trigger values). ANZECC defines a *Slightly to moderately disturbed systems* as an ecosystem in which aquatic biological diversity may have been adversely affected to a relatively small but measurable degree by human activity. Due to the historical industrial activity and residential development within the Lake Macquarie catchment, this catchment fits this definition. Key default trigger values presented in the ANZECC Guidelines for *slightly-moderately disturbed marine systems* in NSW are shown in **Table 2**.

**Table 2 - Key Default Trigger Values for Marine Environment 95% Protection Levels (ANZECC 2000)**

Indicator	Trigger Value micrograms per litre (µg/L)
Ammonia	910
Cadmium	0.7
Chromium	4.4
Cobalt	1
Copper	1.3
Lead	4.4
Mercury	0.1
Nickel	7
Silver	1.4
Vanadium	100
Zinc	15

The Colliery currently utilises the EPL concentration limits as assessment criteria for pH and TSS. In regards to electrical conductivity (EC,) the ANZECC guidelines do not define limits for EC in estuaries and marine environments. However, the Colliery's discharge generally ranges between 13,900 and 34,800 ( $\mu\text{S cm}^{-1}$ ). This concentration reflects the EC within Lake Macquarie which averages between 28,000 and 34,000  $\mu\text{S cm}^{-1}$  (AECOM, 2011) with the lower recorded values a function of rainfall events.

### 2.3.2 NSW Water Quality and River Flow Objectives

*NSW Water Quality and River Flow Objectives* were established by the NSW Government in September 1999 for the majority of NSW catchments. Eleven water quality objectives (WQOs) were developed for NSW rivers and estuaries and provide guideline levels to assist water quality planning and management.

According to the Lake Macquarie and Tuggerah Lakes objectives, Swindles Creek, located adjacent to the Colliery's pit top area, is classified as an "Estuary".

There are numerous WQOs for "Estuaries" within the Lake Macquarie and Tuggerah Lakes catchment depending upon the environmental values within the area. The most relevant of these objectives for Chain Valley Colliery are:

- a) aquatic ecosystems (maintaining or improving the ecological condition of water bodies and their riparian zones over the long term);
- b) visual amenity (aesthetic qualities of waters); and
- c) secondary contact recreation (maintaining or improving water quality for activities such as boating and wading, where there is a low probability of water being swallowed).

Generally the water quality objectives are directly in line with the *Australian and New Zealand Guidelines for Fresh and Marine Water Quality* (ANZECC 2000) default trigger values for slight to moderately disturbed ecosystems in south-east Australia. These values are presented in **Table 3** to **Table 5**.

**Table 3 – Aquatic Ecosystems Guidelines for Estuaries in Lake Macquarie and Tuggerah Lakes**

<b>Aquatic ecosystems</b>	
<b>Relevant Indicator</b>	<b>Criteria</b>
Total phosphorus	30 µg/L
Total nitrogen	300µg/L
Chlorophyll-a	4 µg/L
Turbidity	0.5–10 NTU
Dissolved oxygen	80–110%  Note: Dissolved oxygen values were derived from daytime measurements. Dissolved oxygen concentrations may vary diurnally and with depth. Monitoring programs should assess this potential variability.
Chemical contaminants or toxicants	Table 4 of the WMP or  Table 3.4.1 & 5.2.3 ANZECC (2000)
Biological assessment indicators	This form of assessment directly evaluates whether management goals for ecosystem protection are being achieved (e.g. maintenance of a certain level of species diversity, control of nuisance algae below a certain level, protection of key species, etc.). Many potential indicators exist and these may relate to single species, multiple species or whole communities. Recognised protocols using diatoms and algae, macrophytes, macro-invertebrates, and fish populations and/or communities may be used in NSW and interstate (e.g. AusRivAS).

**Table 4 – Visual Amenity Guidelines for Estuaries in Lake Macquarie and Tuggerah Lakes**

<b>Visual amenity</b>	
<b>Indicator</b>	<b>Criteria</b>
Visual clarity and colour	<p>Natural visual clarity should not be reduced by more than 20%.</p> <p>Natural hue of the water should not be changed by more than 10 points on the Munsell Scale.</p> <p>The natural reflectance of the water should not be changed by more than 50%.</p>
Surface films and debris	<p>Oils and petrochemicals should not be noticeable as a visible film on the water, nor should they be detectable by odour.</p> <p>Waters should be free from floating debris and litter.</p>
Nuisance organisms	<p>Macrophytes, phytoplankton scums, filamentous algal mats, blue-green algae, sewage fungus and leeches should not be present in unsightly amounts.</p>

**Table 5 – Secondary Contact Recreation Guidelines for Estuaries in Lake Macquarie and Tuggerah Lakes**

<b>Secondary contact recreation</b>	
<b>Indicator</b>	<b>Criteria</b>
Faecal coliforms	<p>Median bacterial content in fresh and marine waters of &lt; 1000 faecal coliforms per 100 mL, with 4 out of 5 samples &lt; 4000/100 mL (minimum of 5 samples taken at regular intervals not exceeding one month).</p>
Enterococci	<p>Median bacterial content in fresh and marine waters of &lt; 230 Enterococci per 100 mL (maximum number in any one sample: 450-700 organisms/100 mL).</p>
Algae & blue-green algae	<p>&lt; 15 000 cells/mL</p>
Nuisance organisms	<p>Use visual amenity guidelines.</p> <p>Large numbers of midges and aquatic worms are undesirable.</p>

Secondary contact recreation	
Indicator	Criteria
Chemical contaminants	Waters containing chemicals that are either toxic or irritating to the skin or mucous membranes are unsuitable for recreation.  Toxic substances should not exceed values in tables 5.2.3 and 5.2.4 of the ANZECC 2000 Guidelines.
Visual clarity and colour	Use visual amenity guidelines.
Surface films	Use visual amenity guidelines.

### 2.3.3 NSW State Rivers and Estuaries Policy

The *NSW State Rivers and Estuaries Policy* has three policy objectives to manage the rivers and estuaries of NSW in ways which:

- Slow, halt or reverse the overall rate of degradation in the systems;
- Ensure the long-term sustainability of their essential biophysical functions; and
- Maintain the beneficial use of these resources.

The default ANZECC water quality trigger levels including those identified in Table 2 summarise water quality guidelines proposed to protect and manage the environmental values of national water resources. As such through the adoption of ANZECC, the above guidelines will be met.

### 2.3.4 Environmental Guidelines: Use of Effluent by Irrigation

This guideline is advisory in nature and provides information on best management practices where effluent is managed by irrigation, and is applicable to the irrigation of the treated effluent from the Colliery's administration building.

Primarily this guideline provides information for the design and operation of effluent irrigation systems and is consistent with the *POEO Act*. This guide provides information on the parameters and frequency of monitoring required for effluent water quality and soil contamination. This guideline defines an effluent quality trigger for faecal coliforms of less than 1000cfu/100ml. **Table 6** outlines criteria for the classification of effluent and **Table 7** shows the recommended monitoring frequency for specific soil and water parameters potentially impacted by effluent irrigation.

**Table 6 - Classification of Effluent for Environmental Management**

Constituent	Strength (average concentration mg/L)		
	Low	Medium	High
Total Nitrogen	<50	50-100	>100
Total Phosphorous	<10	10-20	>20
BOD <sup>5</sup>	<40	40-1,500	>1,500
TDS	<600	600-1,000	>1,000-2,500
Other Pollutants (e.g. Metals, pesticides)	Effluent with more than five times the ANZECC and ARMCANZ (2000) long-term water quality trigger values for irrigation waters must be considered high strength for the purpose of establishing a strength class for runoff and discharge controls and will require close examination to ensure soil is not contaminated.		
Grease and Oil	Effluent with more than 1,500 mg/L of grease and oil must be considered high strength and irrigation rates and practices must be managed to ensure soil and vegetation is not damaged.		

**Table 7 - Recommended Effluent Sampling Frequency**

Constituent	Low	Medium	High
TSS	Quarterly	Quarterly	Monthly
Oil and grease	Biannually	Quarterly	Quarterly
Total P	Biannually	Quarterly	Quarterly
Total N	Biannually	Quarterly	Quarterly
BOD <sub>5</sub>	Quarterly	Quarterly	Monthly
PH	Quarterly	Quarterly	Monthly
EC dS/m; TDS	Quarterly	Quarterly	Monthly
Cations	Quarterly	Quarterly	Quarterly
SAR ( $\sqrt{\text{meq/L}}$ )	Quarterly	Quarterly	Quarterly
Metals	Yearly	Yearly	Yearly
Faecal coliforms (cfu/100ml)	Weekly	Weekly	Weekly

### 2.3.5 Managing Urban Stormwater: Soils and Construction

In NSW, the most relevant and comprehensive guidelines for the designs of stormwater controls relating to mines is contained in *Managing Urban Stormwater: Soils and Construction Vol 2E – Mines and Quarries* (DECC, 2008) in conjunction with the references to Volume 1 (Landcom, 2004). Both of these references are referred to in this report as the *Blue Book*. The principles of surface water control, including the design of ESC structures, have been adopted in this SWA where applicable.

### 2.3.6 NSW Farm Dams Policy

The *NSW Farm Dams Policy* was introduced in 1999. Under this policy it is not necessary to obtain a licence or other consent from DECCW for a farm dam provided:

- They are not collecting flow from a major stream; and
- The combined capacity does not exceed the Maximum Harvestable Rights Dams Capacity (MHRDC) for the property.

#### **2.3.6.1 Maximum Harvestable Right Dam Capacity**

All the sedimentation ponds are exempt from harvestable right calculations under the *NSW Farm Dams Policy*. This is because the purpose of the ponds is to prevent the contamination of downstream waterways.

## 3.0 EXISTING SURFACE WATER ENVIRONMENT

### 3.1 Climate / Rainfall

The Lake Macquarie region has a borderline oceanic/humid subtropical climate like much of central and northern NSW. Summers tend to be warm and winters are generally mild. Precipitation is heaviest in late autumn and early winter.

A review of the Bureau of Meteorology (BOM) website indicated that there were no weather stations located in the immediate vicinity of the Site, however, numerous stations were identified in the general Lake Macquarie region. All of these weather stations contain similar average annual rainfall statistics. Together, these weather stations contain over 100 years of complete daily rainfall data which made it suitable for use in the detailed water balance described in **Section 5.3.1**. Rainfall statistics for the Colliery region include:

- Minimum annual rainfall – 600mm in 1944;
- Average annual rainfall – 1206mm;
- Median annual rainfall – 1155mm; and
- Maximum annual rainfall – 2031mm in 1990.

The average annual evaporation at the Site is approximately 824mm and is highest in December and lowest in June. Additional information on the evaporation data and trends at the Site is provided in **Section 5.3.2**.

### 3.2 Landform

The Colliery's pit top area is relatively flat with the majority of the runoff flowing east into the sedimentation ponds, prior to discharge. Earthen diversion drains exist on the northern and eastern boundaries and help to convey this runoff into the ponds. Overflow from the sedimentation pond system discharges to Swindles Creek which flows into Lake Macquarie.

The car park and the adjacent access road are the only areas where the runoff does not discharge into the sedimentation ponds and is conveyed directly off-site. Management of the carpark runoff has recently been reviewed at the Colliery with recommendations and commitments provided within the Colliery's Water Management Plan (WMP) (**Appendix B**). No watercourses traverse the pit top facilities.

### 3.3 Surrounding Land Uses

The Colliery's pit top area is located on the western side of Chain Valley Bay, on relatively flat land, largely devoid of vegetation. It is situated in an existing industrial area accessed from Ruttleys Road.

The existing ventilation shaft and fans are located on freehold land at Tiembula Road, Summerland Point, on the eastern side of Chain Valley Bay. Parts of the Lake Macquarie State Conservation Area are located on both the eastern and western sides of the lake, which provide bushland and open space along the foreshore.

Neighbouring industrial facilities comprise Mannering Colliery to the south and Vales Point Power Station to the west. The nearest residential areas are Kingfisher Shores and Chain Valley Bay to the

south-east, Mannering Park to the north-west, and Summerland Point and Gwandalan to the north-east.

The area surrounding the Colliery is also used for a number of recreational purposes. Fishing and sailing are popular on Lake Macquarie, along with other water based recreational activities. Camping facilities, walking tracks and picnic areas are available within the Lake Macquarie State Conservation Areas.

### 3.4 Soils / Geology

The Colliery's surface facilities are situated on the shore of Lake Macquarie. This area principally comprises the Doyalson soil landscape with small parts on the Wyong soil landscape. The Doyalson soil landscape is characterised by gently undulating rises on Munmorah Conglomerate with broad crests, ridges and long gently inclined slopes. Local relief is up to 30 metres and slope gradient is less than 10%. Doyalson soils are strongly acidic, of low fertility and exhibit slight to high erodibility. The Wyong soil landscape is characterised by broad, poorly drained deltaic floodplains and alluvial flats of Quaternary sediments. Local relief is less than 10 metres and slope gradient is less than 3%. Wyong soils are strongly acidic, poorly drained, impermeable, of very low fertility and contain saline subsoils.

### 3.5 Existing Surface Water Quality and Assessment Criteria

#### 3.5.1 Licensed Discharge Points

The discharge of excess mine water from the sedimentation and pollution control ponds is licensed under the *POEO Act* by the Environment Protection Authority (EPA) through the Chain Valley Colliery Environment Protection Licence (EPL 1770). Under EPL 1770 there is a single licensed discharge point for the Colliery (LDP 1) shown in **Figure 4.1**. The EPL has been modified a number of times, most recently in December 2011. A draft variation to EPL 1770 was also submitted by LakeCoal to the EPA on 7<sup>th</sup> February 2012. The EPA subsequently issued a draft variation to LakeCoal on 14<sup>th</sup> November 2012 which LakeCoal responded to with comments on 3<sup>rd</sup> December 2012. LakeCoal had not received any further feedback from the EPA and had not been issued with the EPL variation at the time this SWA was finalised (February 2013).

LDP 1 has a daily discharge limit of **12,161 kL/day** and a limit for pH and TSS as shown in **Table 8**.

**Table 8: Concentration Limits for LDP 1 (EPL 1770)**

Pollutant	Unit of Measure	100 <sup>th</sup> percentile Concentration Limit
pH	pH	6.5-8.5
TSS	Milligrams per litre (mg/L)	25

Currently, discharge from Site is un-metred and is calculated from continuous monitoring of the underground pumping rates and surface flow meters. Water currently leaks from Pond D10 as per **Figure 4.1** and much of this water does not pass through LDP 1. LakeCoal is committed to rectifying LDP 1 and has engaged a dam engineer to design a metred spillway to be able to obtain direct measurements of the daily discharge from Site. LakeCoal is committed to upgrading the main embankment, spillway and discharge monitoring point of the final sediment dam as part of the Proposal.

EPL 1770 initially contained two discharge points, one at the pit top area (current) and a second at the Ventilation Shaft Site. These two points had individual discharge limits of 8161 kL/day and 4000 kL/day respectively. The separate discharge points related to the workings in both the Wallarah and Great Northern Seams, which had different pumps and pump out lines. With the cessation of mining in the Wallarah Seam (1997), the subsequent construction of a dewatering borehole from the Wallarah to the Great Northern Seam, and decommissioning of the pump out line leading to the Ventilation Shaft Site in 2003, the EPL was amended to combine the discharge volume limit (12,161 kL/day) to the single point at the pit top area as is currently contained in EPL 1770. It is expected that these volumes were originally based on mine dewatering data, with no consideration given to surface water runoff volumes.

### 3.5.2 Existing Surface Water Quality

Generally, the main runoff pollutants from the pit top area (including soils, roads and coal handling areas) comprise sediment and coal fines, which are both treated in the sedimentation ponds. However, there is some potential for this pit top runoff to contain hydrocarbons. Runoff from all areas where this is likely is directed to the oil/water separator, as described in **Section 4.2.6**. Water pumped from underground is saline and contains a number of heavy metals with concentrations elevated above ANZECC criteria. The management of this underground water is discussed in **Section 6.2.1**.

Due to the age of the Colliery and its previous operation under existing use rights, limited baseline water quality data was collected prior to Project Approval (MP 10\_0161). However, following the project approval, regular sampling has been undertaken. Since 2008, regular water quality samples have been taken from LDP 1, and since September 2011, this sampling has been expanded to include upstream and downstream monitoring. The analysis results of these samples are presented in **Appendix A**.

One purpose of the monitoring currently undertaken is to enable site specific trigger values to be developed. The Colliery requires a minimum of 2 years of monthly sampling data for this to occur. Though baseline data only requires 2 years of data, LakeCoal intends to continue the monitoring program into the future with ongoing reviews of the developed site specific triggers and monitoring regime, based on the data collected.

EPL 1770 only sets concentration limits for pH and TSS, however it also defines a number of other pollutants to monitor. Regular monitoring of these pollutants has been undertaken as per the requirements of the EPL. In the absence of extensive baseline data, the most relevant water quality guidelines for the pollutants not covered by the EPL are the default trigger values presented in the *Australian and New Zealand Guidelines for Fresh and Marine Water Quality* (ANZECC, 2000) for slightly to moderately disturbed estuaries and marine environments in NSW.

The baseline data from LDP 1 presented in **Appendix A** shows that, historically, zinc, nickel, silver, copper, cobalt, cadmium and aluminium levels have exceeded the ANZECC guidelines. However, post-August 2010, the sampling procedure was improved to enable dissolved and total concentrations to be differentiated. Following the application of the improved monitoring procedure all pollutants have been below the ANZECC guidelines with the exception of copper and zinc which have had concentrations recorded slightly above the ANZECC guidelines (refer to **Appendix A** for more details).

A similar trend was observed in samples taken from the main pond discharge point except at this location, aluminium also exceeded the ANZECC trigger values on one occasion. It should be noted that aluminium and copper levels have routinely exceeded ANZECC guidelines in the upstream sampling point and aluminium, zinc and copper levels have exceeded ANZECC guidelines in the downstream sampling location.

Although it is recognised that some of the metal concentrations have exceeded the ANZECC (2000) criteria, it has not yet been established whether the results are indicative of on-site sources, upstream sources and/or background conditions.

In addition to the required monitoring, total oil and grease, anionic surfactants such as MBAS and faecal coliforms are also regularly monitored. The ongoing monitoring requirements are addressed in the **Section 8.0**.

## 4.0 EXISTING SURFACE WATER MANAGEMENT

Current water management is segregated into clean and dirty water systems and is achieved through the use of purpose built controls. The existing WMP for the Colliery was prepared in 2012 and consolidated the existing water management practices utilised at the pit top area with the water management requirements outlined in the Environmental Assessment (EA) prepared by AECOM in 2011 and subsequent project approval (MP 10\_0161). A copy of the WMP is contained in **Appendix B**. An overview of the water management system at the pit top area is detailed below and shown on **Figure 4.1**. A schematic water flow diagram of the existing water management system is shown on **Figure 4.2**.

### 4.1 Existing Erosion and Sediment Control Structures

ESC structures are implemented across the Colliery's surface activities for all phases of the operation - including construction, operational, and maintenance activities - to mitigate the potential impact on watercourses and the surrounding environment. Water management at the Colliery comprises capture and treatment of 'dirty' water runoff from disturbed areas and underground water pumped from the main Great Northern Seam Sump. All surface mine water and underground mine water is captured by the Colliery's sedimentation dams prior to discharge under EPL 1770. The ponds discharge through LDP 1 into native vegetation and flow to Swindles Creek prior to draining into Lake Macquarie on the western shoreline of Chain Valley Bay. The ventilation shaft and fan site on the eastern side of Chain Valley Bay will not require upgrades to water management as a result of the Proposal. As such, this site is not considered further in this SWA. The WMP (**Appendix B**) contains further information on ESC structures to be used at the Colliery.

#### 4.1.1 Clean Water Diversion

During the development of the WMP, improved clean water management was recommended through the use of catchment separation and the diversion of collected clean water away from disturbed areas through diversion banks and channels. In addition to this recommendation protection for the receiving environment is currently being improved by passing the clean water runoff through a basin prior to discharge from site. This basin is sized to provide an area where ponding can occur and allow coarse sediment to settle out and then to be removed. LakeCoal is currently in the process of implementing these recommendations.

#### 4.1.2 Pit Top Catchment Areas

For the purpose of the SWA, runoff from the pit top area has been assessed in terms of four main catchment areas (shown in **Figure 4.1**) including:

- Catchment 1 – The carpark, office building and partial runoff from the workshop roof;
- Catchment 2 – The rear storage yard and oil water separator and the remaining workshop roofed area;
- Catchment 3 – The stockpile, entry road and bathhouse; and
- Catchment 4 – The sedimentation ponds.

Runoff from Catchment 1 has historically been considered clean catchment and as a result was not subject to water quality treatment. While a large portion of this area is undisturbed, the carpark is unsealed (gravel hardstand) and is responsible for some deposition of sediments in the adjacent drainage swales. Additionally runoff from the main entry and haul road has been occasionally reporting to this drainage swale resulting in the accumulation of coal fines. Formalised control

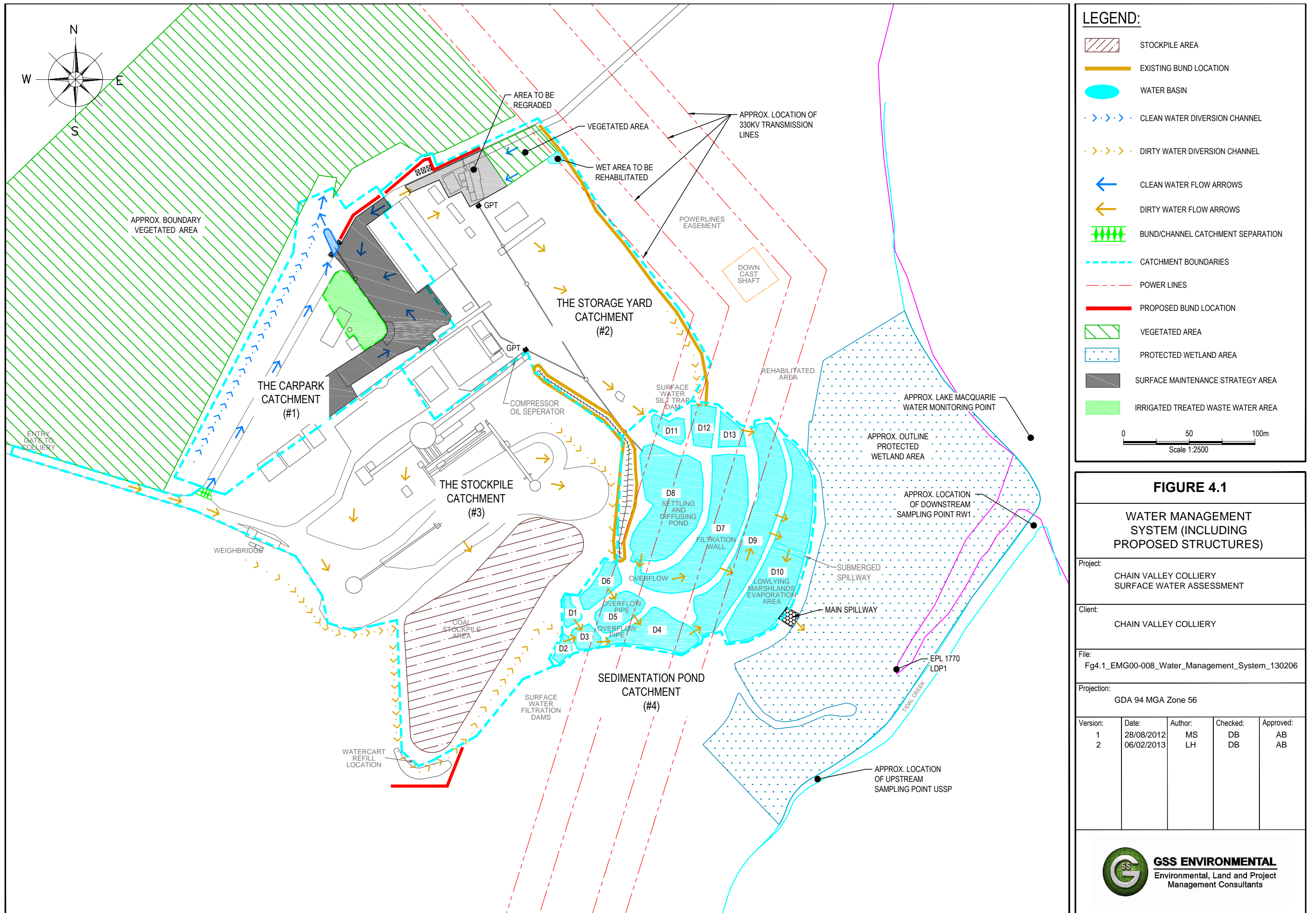

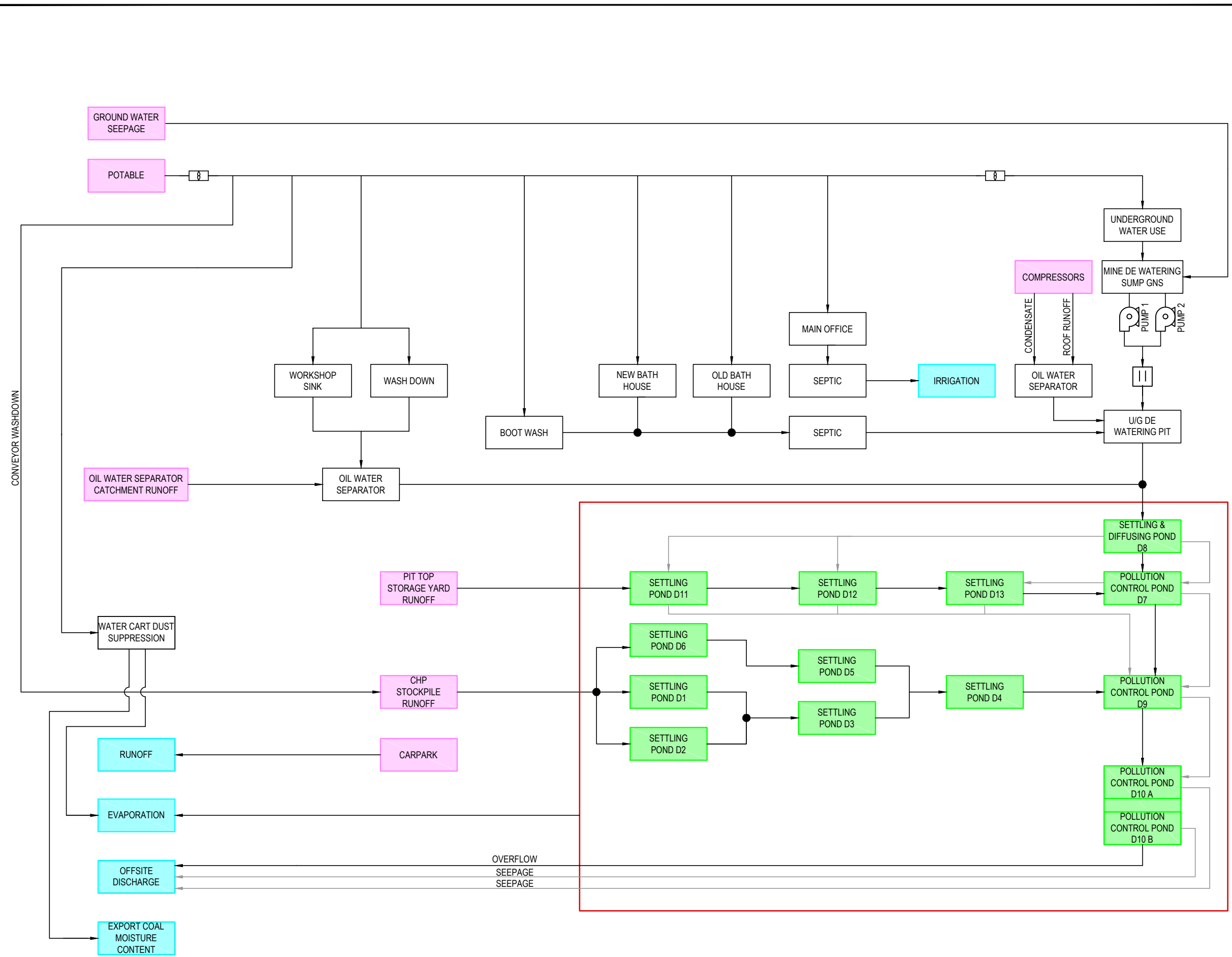

**LEGEND**

- WATER STORAGE
- WATER INPUTS
- WATER OUTPUTS
- PUMPS
- MECHANICAL FLOW METER
- MAGNETIC FLOW METER
- FLOW DIRECTION

**FIGURE 4.2**

**EXISTING WATER MANAGEMENT SYSTEM SCHEMATIC**

Project:  
CHAIN VALLEY COLLIERY  
SURFACE WATER ASSESSMENT

Client:  
CHAIN VALLEY COLLIERY

File:  
Fg4.2\_EMG00-008\_Water\_Management\_System\_120904

Projection:  
MGA\_94 - ZONE 56

Version:	Date:	Author:	Checked:	Approved:
A	28/08/2012	MS	DB	AB
B	04/09/2012	MS	DB	AB

**GSS ENVIRONMENTAL**  
Environmental, Land and Project  
Management Consultants

structures to improve the runoff water quality from this catchment are described in the WMP (**Appendix B**).

The majority of runoff from Catchment 2 currently drains east into the sedimentation ponds via a pit and pipe network and earth bunding. Runoff from the area surrounding the oil water separator currently drains to an adjacent swale and is responsible for the deposition of fine sediments in this swale. The majority of the storage yard is gravelled hardstand, however, there are some exposed disturbed areas due to regular heavy vehicle movement resulting in runoff also containing sediment. This runoff is captured within the pollution control dams (dams D11, D12 and D13 shown on **Figure 4.1**) which function as primary settling ponds prior to discharge into the main sedimentation ponds D7 and D9.

Runoff from Catchment 3 is contained by two main drainage channels that surround the coal stockpile and report to the sedimentation ponds (Catchment 3). Runoff from this area contains a significant amount of coal fines. The runoff from the area adjacent to the weigh bridge currently collects and pools in an adjacent drainage channel. Runoff from the main entry/haul road contains coal fines and a small component of this catchment has been reporting to the clean water carpark catchment (Catchment 1). The majority of the runoff from Catchment 3 reports to sedimentation dams D1 to D6 (Catchment 4). These dams also function as primary settling ponds before discharging into the main mine water sedimentation ponds. A small portion of the area surrounding the Run-of-Mine (ROM) bin and bathhouse, reports to the storage yard area (Catchment 2).

The WMP includes measures to improve water management on site and ensure water management structures comply with industry best practice. Refer to the **Section 6.4** for details on the proposed changes relating to ESC. The minor upgrades and modifications to infrastructure proposed at the pit top area will not increase volumes of stormwater runoff from the Site.

#### **4.1.3 Sedimentation Ponds**

With the exception of the carpark stormwater runoff, all of the Colliery's 'dirty' water including surface water runoff, septic treated bathhouse wastewater, treated water from the oil water separator and underground mine water is conveyed into the sedimentation ponds (shown in **Figure 4.1**) prior to discharge under EPL 1770. These ponds treat the collieries wastewater and runoff quality through the settlement of fines and suspended solids. In addition, they also prevent hydrocarbon spills from discharging off-site and into Lake Macquarie. They have been constructed with a mixture of earth, crushed rock, crushed recycled brick and stone and are interconnected through a series of overflow pipes and spillways.

Water is directed through the ponds from a number of inlet locations. A detailed survey of the ponds was undertaken by Pearson and Associates in 2009 with the relative storage capacities provided in **Table 10**. Runoff from the stockpile area is collected primarily by ponds D1, D2 and D6 and is combined into D4 and D5 before flowing into D9. Runoff from the storage yard is directed to D11, D12 and D13 before also overflowing into D9.

The underground mine water is pumped to a pit adjacent to the compressor house and is combined with the septic treated wastewater from the bathhouse, the treated compressor condensate water and runoff from the ROM bin area. From this pit, the water is piped to D8 for settling and diffusion. Water within D8 spills into D7 via a spillway at the southern end of the pond. However, due to the leaky nature of the ponds an unknown amount of water diffuses through the pond walls. The water in D7 flows into D9 in a similar manner. In D9 the underground water is combined with the pit top runoff.

The primary spill from D9 to D10 is at the northern end of D9. Once in D10, the water travels over a shallow buffer spillway to the main discharge spillway and offsite at LDP 1. Currently the main discharge from the LDP is un-metred and the quantity of water discharged from site is calculated from continuous monitoring of the underground pumping rates and surface flow meters. As noted in

**Section 3.5.1**, LakeCoal is committed to upgrading the main embankment, spillway and discharge monitoring point of the final sediment dam.

## 4.2 Additional Water Management

In addition to ESC structures, there are a number of additional water management areas implemented at the Colliery. These are described below.

### 4.2.1 Potable water

Potable water, obtained from the Wyong Shire Council, provides the water required to support the Colliery's operation. Information supplied by LakeCoal indicates that approximately 132 ML/year of portable water is used by the Colliery. Potable water is consumed in the following processes:

- When cutting coal at the coal face - to reduce respirable dust and propensity for frictional ignition of coal dust and methane gas;
- When transferring coal along the underground conveyor system and at transfer points - to reduce dust make;
- In cleaning;
- In equipment;
- For drinking water supply;
- For emergency fire fighting purposes; and
- Pit top amenities, wash down and dust suppression activities.

It is estimated that approximately 20 ML/year (15%) is used for pit top operations and 112 ML/year (85%) is used in the underground operations. As required by Schedule 3, Condition 31(d) of MP10\_0161, practical measures to minimise potable water consumption and maximise recycled water use have been and continue to be investigated by LakeCoal, as discussed in the WMP (**Appendix B**). Potential initiatives currently being investigated include;

- Reuse of dirty water contained within the sedimentation ponds for dust suppression purposes;
- Using the water cart for dust suppression of the ROM stockpile instead of the existing sprinkler system which is less efficient with water and is currently not operational; and
- Installing rainwater tanks on the operations block and workshop area including plumbing to the bathhouse.

However, the use of non-potable water in all operational activities is not possible due to its quality, work health and safety and equipment requirements.

### 4.2.2 Groundwater

In addition to the potable water, naturally saline groundwater migrates into the Colliery's underground workings. This water is pumped to the main sump within the Great Northern Seam, and then to the sedimentation ponds on the surface. This water cannot be used for operational purposes due to its high salinity.

### **4.2.3 Dust Suppression**

An estimated 11-12 ML/per year of potable water is currently used for dust suppression. A reduction in the consumed volume is anticipated through the implementation of water for dust suppression on the ROM stockpile, haul roads and storage yard being preferentially sourced from the sedimentation ponds.

### **4.2.4 Alternative Supply**

An investigation has been undertaken to source water from the Mannering Park Sewerage Treatment Plant (STP) following Reverse Osmosis (RO) treatment at Vales Point Power Station (VPPS). However, currently all available water is consumed in the VPPS operations.

As required in the future, alternative water sources will be investigated. The current considerations for alternative water supply include the surrounding unutilised bores and a comprehensive rain water harvesting system.

### **4.2.5 Wastewater Disposal and Management**

There are two sources of domestic wastewater located at the pit top, namely the administration office building, and the bathhouse and operations area. Both wastewater streams are treated by separate treatment systems. The administration office stream treatment system comprises an aerated wastewater treatment system (AWTS) while the bathhouse system is a traditional septic system comprising a three part septic tank system. Following treatment, the office waste water is reused to irrigate the landscaping surrounding the office building via a drip irrigation system, while the bathhouse wastewater is discharged to the pollution control ponds.

LakeCoal is currently seeking to improve the effluent management on site by improving the quality or reducing the quantity of effluent discharged to the pollution control ponds and is currently seeking advice from Wyong Shire Council on the feasibility of connecting into a sewage pipeline located to the east of the pit top. This connection would enable the main waste water streams to be removed from the pollution control ponds on site.

During investigations into the feasibility of this connection, Chain Valley proposes to characterise the effluent waste streams and monitor the quality of the water discharged from the pollution control ponds for water quality parameters relevant to effluent. As discussed in **Section 8.5.1** and within the WMP (**Appendix B**), increased monitoring of both the effluent and effluent irrigation area is also undertaken, and will continue during the life of the Proposal, in accordance with the WMP.

### **4.2.6 Oil Water Separation**

Water that is likely to be contaminated with oil and grease, such as runoff from the oil storage facilities, diesel tank storage, workshop/maintenance areas and wash bay is directed to and treated by an oil water separator. This system consists of a packed bed oil separation system where solids are removed in the grit trap, and oily water is drawn from the sump through a floating skimmer into the packed bed oil separator by a non-emulsifying pump. The oil water separation system was upgraded in 2012 and has a capacity of 2000L/hr through flow. The waste oil is collected in a container and the treated water flows by gravity to the sedimentation ponds.

An additional oil water separation system is installed on the condensate drain from the compressors on site. This system consists of an underground tank where water is passed through an under over weir arrangement prior to discharge to the sedimentation ponds.

## 5.0 SITE WATER BALANCE

### 5.1 Introduction

As part of this SWA, it was necessary to demonstrate that the proposed water management practices will comply with licence conditions with respect to discharge, or if this is determined to be unachievable, recommend mitigation and/or management measures to enable these conditions to be achieved. A site water balance has been developed to understand water demands and flows around the pit top area (surface component of the mine).

A water balance was undertaken for the site by AECOM in July 2011. The water balance investigation for the Proposal was undertaken independently from this previous water balance with only some model inputs compared for verification. This new water balance included a more detailed investigation of the pit top water use to aid the future decision making process in regards to water management at the Colliery. This site water balance (provided in **Appendix C**) includes commitments regarding water savings measures to be implemented at the Colliery including the use of rainwater tanks and the reuse of dirty water from the sedimentation ponds for dust suppression purposes.

The model used to represent the Colliery water balance was GoldSim Version 10.50 (GoldSim Technology Group LLC). This software is a graphical, object oriented system simulation software for completing either static or dynamic systems. It is like a “visual spreadsheet” that allows one to visually create and manipulate data and equations. GoldSim is commonly used to undertake ‘daily time step’ water balance simulations for coal mines within NSW due its enhanced modelling capability and flexibility compared to spreadsheet models that have predominately been used in the past.

### 5.2 Model Representation and Accuracy

The Colliery water cycle, as proposed (including increased quantities of water make from underground, rainwater tanks and reuse of dirty water from dams for dust suppression purposes etc.) is shown in **Figure 4.1**, with a schematic water flow diagram provided in **Figure 5.1**. This system was simplified and modelled in GoldSim as shown in **Figure 5.2**. The following simplifications were incorporated in the model:

- Daily time steps over a simulation length of over 100 years were used for the analysis – daily rainfall data was the shortest data period available;
- A monte carlo (probabilistic) simulation with 100 realisations to simulate the uncertainty in the model results brought about by the variation in pumped flows from underground, and a deterministic simulation to model water processes at the site when pumping at the maximum pump rate from underground (worst case scenario);
- The underground storages within the Wallarah and Great Northern Seams were not modelled in the water balance due to operational uncertainties and uncertainties regarding the actual size of these storages. Based on information provided by LakeCoal, these underground storages were assumed to be sufficient to store water during periods of wet weather;
- The carpark catchment runoff was not included in the water balance as it does not report to the sedimentation ponds;
- Runoff from catchments was represented by an initial loss/runoff factor, as described in the site water balance report (**Appendix C**);
- The compressors at the site were not included for simplicity as their contribution to the overall water cycle was considered to be negligible;
- Operating rules/precedents were established within the model in accordance with advice from LakeCoal. In reality the same decisions may not be made by staff due to influences outside the model;

- Rainwater tanks collecting runoff from the workshop and old bath house roofed areas were modelled as an individual tank. Overflow from this combined tank was modelled as occurring when the capacity of the tank exceeded 80% of the overall capacity. Similarly, the tank was filled up with potable water when the capacity dropped below 20% of the overall capacity to ensure water was always available for proposed uses (toilet flushing and bootwash etc.);
- Ponds D1 to D6 and Ponds D7 to D13 were each modelled as single storages to simplify the water balance processes at the site;
- No amenity potable water used (sinks, showers, toilets, etc.) was assumed to be lost from the water balance system. In reality a small fraction of this water may be lost (e.g. through consumption, etc.) however this loss was considered to be negligible in regards to the overall site water balance; and
- Daily dust suppression was modelled to occur on days when less than 5mm of rain fell on the site. This dust suppression water was then modelled as leaving the site via either evaporation or within the exported coal.

The accuracy of the model and results are limited by the following factors:

- Lack of sub metering data regarding pit top and specific areas of underground usage of potable water;
- Lack of water cart usage records to calculate seasonal dust suppression rates. Records from Summer and Autumn were available and an average daily dust suppression rate from these records was calculated and used in the water balance; and
- Distance between Peats Ridge BOM weather station (used for pond evaporation rates) and the site of 33km.

The effect of these errors is considered to be negligible in comparison to the variation in the daily volumes of water being extracted from the underground workings. It is also important to note that the volumes of water discharged via LDP 1 are not currently metered and hence the extent of any errors cannot be verified. Reference should be made to the Groundwater Assessment Report (Geoterra, 2012) regarding the accuracy of the expected volumes of water make as a consequence of underground mining that must be pumped to the surface and, ultimately, to the LDP.

Calibration of the model parameters was not possible in this investigation due to the lack of downstream monitoring information at LDP 1. A broad brush validation of the model results was undertaken based on a range of Average Recurrence Interval (ARI) rainfall events, a generalised estimate of storage capacity available within the sedimentation ponds, pumping rates, catchment areas and runoff coefficients. This 'sanity check' of the results demonstrated a strong correlation between the site discharges calculated for certain rainfall events and within the GoldSim model.

Where assumptions have been made, they have generally been conservative. Therefore, results presented in this section are considered to represent potential worst case impacts.

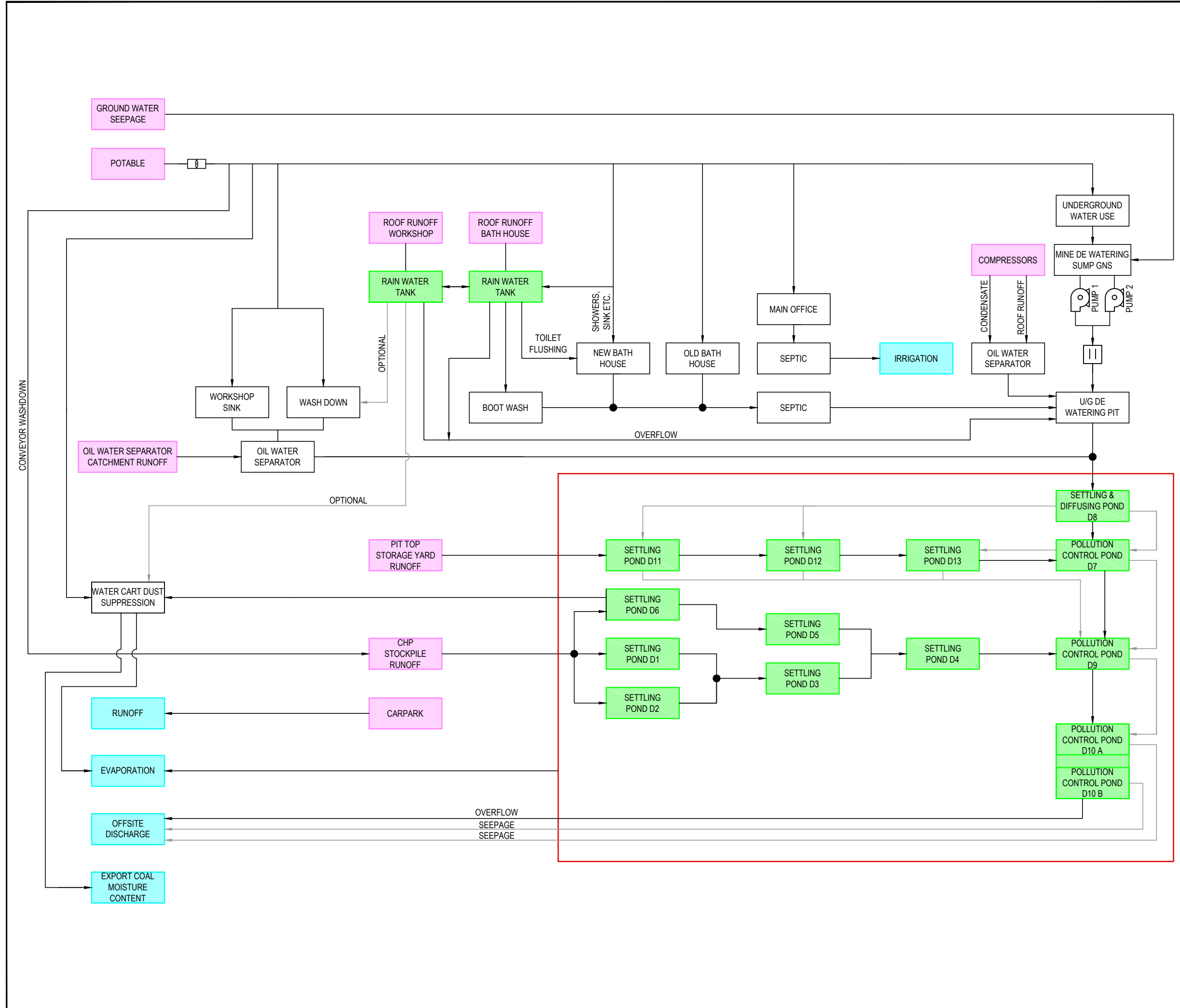

### LEGEND

- WATER STORAGE
- WATER INPUTS
- WATER OUTPUTS
- PUMPS
- MECHANICAL FLOW METER
- MAGNETIC FLOW METER
- FLOW DIRECTION

### FIGURE 5.1

#### PROPOSED WATER MANAGEMENT SYSTEM SCHEMATIC

Project:  
CHAIN VALLEY COLLIERY  
SURFACE WATER ASSESSMENT

Client:  
CHAIN VALLEY COLLIERY

File:  
Fg5.1\_EMG00-008\_Water\_Management\_System\_120904

Projection:  
MGA\_94 - ZONE 56

Version:	Date:	Author:	Checked:	Approved:
A	28/08/2012	MS	DB	AB
B	04/09/2012	MS	DB	AB

**GSS ENVIRONMENTAL**  
Environmental, Land and Project  
Management Consultants

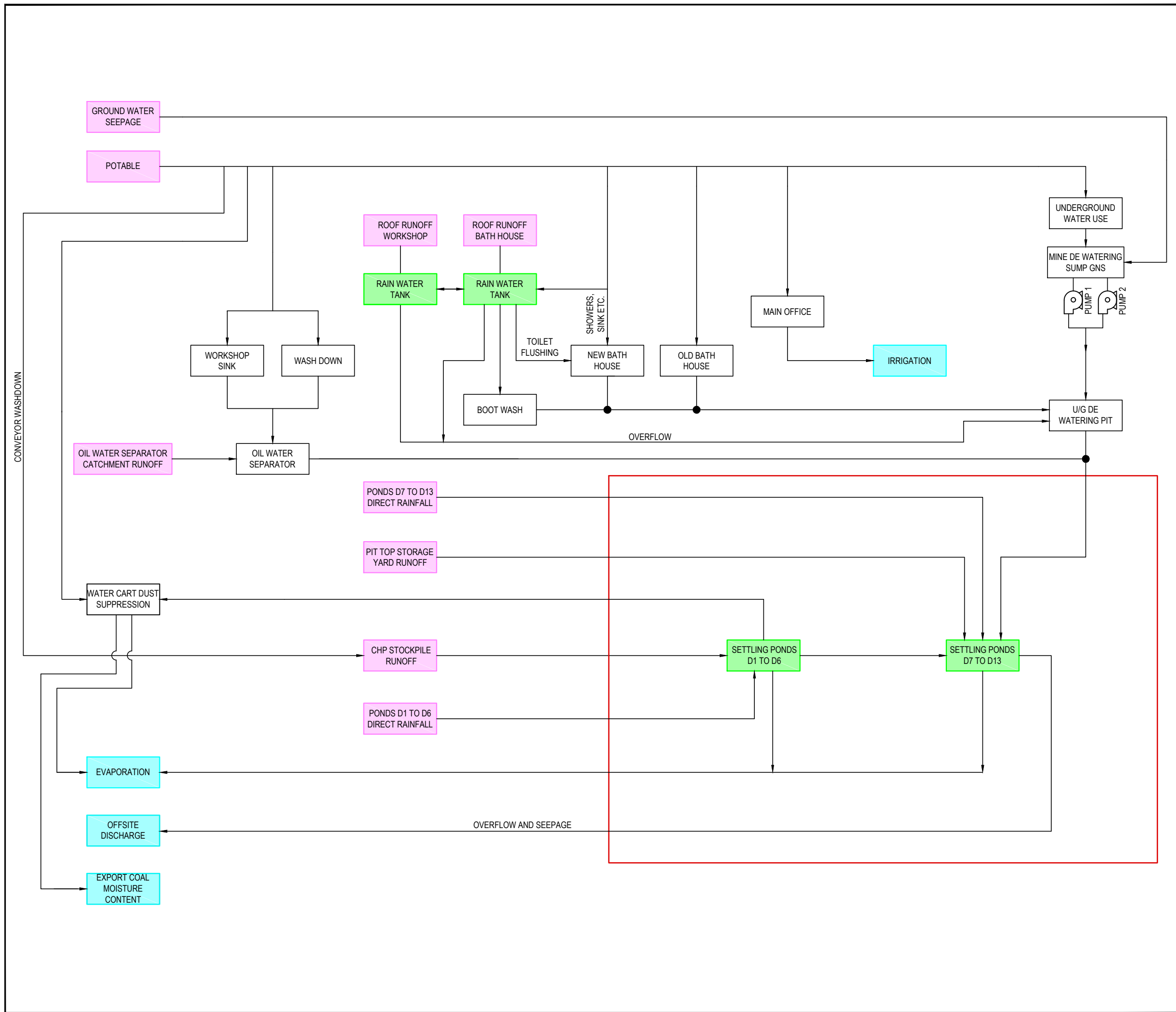

**LEGEND**

- WATER STORAGE
- WATER INPUTS
- WATER OUTPUTS
- PUMPS
- FLOW DIRECTION

**FIGURE 5.2**

**WATER BALANCE SCHEMATIC  
AS MODELLED IN GOLDSIM**

Project:  
CHAIN VALLEY COLLIERY  
SURFACE WATER ASSESSMENT

Client:  
CHAIN VALLEY COLLIERY

File:  
Fg5.2\_EMG00-008\_Water\_Management\_System\_120904

Projection:  
MGA\_94 - ZONE 56

Version:	Date:	Author:	Checked:	Approved:
A	28/08/2012	MS	DB	AB
B	04/09/2012	MS	DB	AB

**GSS ENVIRONMENTAL**  
Environmental, Land and Project  
Management Consultants

### 5.3 Data (Model Inputs and Outputs)

#### 5.3.1 Rainfall Runoff

##### 5.3.1.1 Rainfall

There are no long term weather stations located in the immediate vicinity of the Site, however numerous stations are located in the general Lake Macquarie region. Rainfall data was obtained from the BOM's website for these stations. A comparison of the average annual rainfalls at these stations is provided in the water balance (**Appendix C**). Rainfall information for a weather station at Mannering Colliery was also obtained. However, only 14 months of data was available. It was therefore excluded from the water balance model.

The dataset developed for the water balance used information from the Wyee and Norah Head stations. There are other stations in the general vicinity, however these stations (Wyee and Norah Head) were selected due to their proximity to the Colliery and length and completeness of the data, which together, provide over 100 years of rainfall data. A summary of the annual rainfall data used in the water balance is provided in **Figure 5.3**.

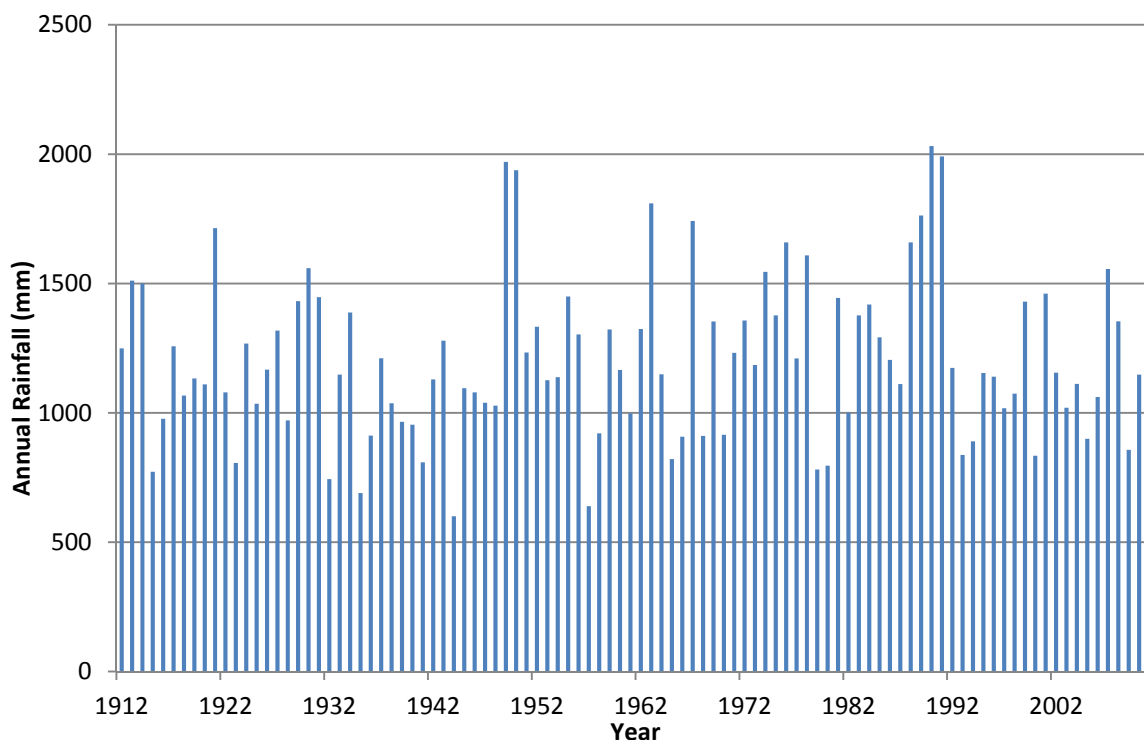

**Figure 5.3 – Annual Rainfalls in Chain Valley Region**

##### 5.3.1.2 Runoff

Runoff volumes from the pit top areas were estimated using the rainfall data described above. The pit top area was segregated into four distinct catchments (as summarised in **Section 4.1.2**) using contour information provided by LakeCoal, information from the EA (AECOM 2011) and observations made by GSSE personnel during previous site inspections. These catchments were further broken up into eight sub-catchments for the purpose of the Colliery's water balance, as shown in **Table 9**.

With the exception of the carpark, runoff from each of these sub-catchments is directed to the sedimentation ponds. LakeCoal has committed to installing rainwater tanks connected to the

workshop and old bath house roofs. As such, these were included in the GoldSim model. Runoff from the car park discharges directly off-site, hence it is not part of the mine water cycle. Management of this carpark runoff has recently been reviewed at the Colliery with proposed water quality control measures contained within the WMP.

The daily step GoldSim model was used to estimate the surface water runoff from different sub-catchments at the pit top area. An initial loss and runoff factor was assigned to each sub-catchment. This was used to convert daily rainfalls into surface runoff values when the daily rainfall exceeded the initial loss of rainfall.

All hardstand areas were assigned an initial loss value of 2mm and a runoff factor of 0.9 which equates to a high proportion of rainfall/runoff. These runoff coefficients are considered conservative but reflect the large impermeable area in the catchment which includes laydown areas, compacted roads and coal stockpile areas. The free water surfaces of the sedimentation ponds and the roofed areas were modelled as completely impervious areas, capturing all precipitation.

Catchment areas and the estimated average annual runoff volumes estimated from the GoldSim model are provided in **Table 9**. This table also indicates which of the four main catchments (as shown in **Figure 4.1**) that these more specific areas fall within.

**Table 9 – Pit Top Catchment Areas, Soil Loss Parameters and Estimated Average Annual Runoff Volumes**

Major Catchment Name	Sub-Catchment Name	Catchment Area (ha)	Initial Soil Loss (mm)	Runoff Factor	Average Annual Runoff Volume (ML/year)
Carpark (Catchment 1)	Carpark (not modelled)	NA	NA	NA	NA
Storage Yard (Catchment 2)	Oil Water Separator	0.15	2	0.9	1.40
	Workshop (Roof)	0.24	2	0.9	2.82
	Old Bath House (Roof)	0.11	2	0.9	1.29
	Pit Top Storage Yard	3.03	2	0.9	27.63
Stockpile (Catchment 3)	CHP Stockpile	5.34	2	0.9	48.70
Sedimentation Ponds (Catchment 4)	Ponds D1 to D6	0.41	0	1.0	4.93
	Ponds D7 to D13	1.97	0	1.0	23.54
<b>Total Catchment reporting to Sedimentation Ponds (excluding carpark)</b>		<b>11.25</b>	<b>-</b>	<b>-</b>	<b>110.31</b>

### 5.3.2 Evaporation

Evaporation data was obtained from the BOM's station at Peats Ridge on Waratah Road (station number 61351), approximately 33km south-west of the mine. This was the closest meteorological weather station to the Colliery with over 25 years of evaporation information. Evaporation data from this weather station was adjusted for the change in site conditions from the measuring site to the sedimentation ponds by multiplying the average monthly rates by a pan coefficient of 0.7.

**Figure 5.4** provides a representation of the adjusted average monthly evaporation at this weather station.

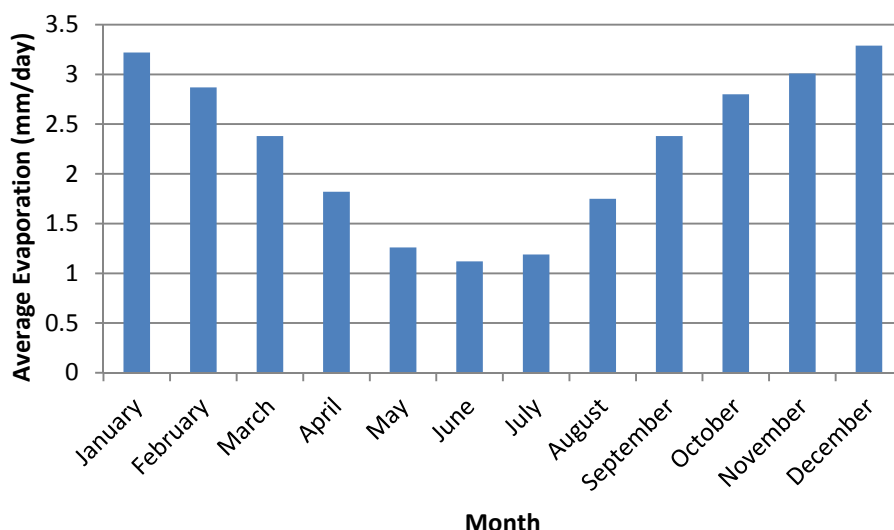

**Figure 5.4 – Average Adjusted Monthly Evaporation Rates**

The average annual evaporation rate was approximately 824mm as compared to the annual average rainfall of approximately 1206mm, giving an annual surplus (difference between annual rainfall and annual evaporation) of approximately 382mm.

Evaporation from the sedimentation ponds was calculated using a daily step within the GoldSim model similar to the runoff model calculations. This model used the evaporation rate, modified by the pan coefficient, and the surface area of the ponds, which was calculated using survey data provided by LakeCoal. Modelling in GoldSim indicated that approximately 19.2 ML of water would evaporate out of the sedimentation ponds on average every year.

### 5.3.3 Underground Water Extraction

The Groundwater Assessment (Geoterra, 2012) undertaken for this Proposal predicted that the average daily water volumes pumped from the coal face would increase from approximately 7.3 ML/day to 10.5 ML/day as a result of the Proposal. This estimated pumping rate is an average value and therefore pumped flow rates may exceed this value on occasions. It should be noted however, that this average daily volume was calculated as an ‘end of mining’ estimate and can be considered a ‘worst case’ prediction of groundwater inflow rates and is not expected to occur for the majority of the Proposal life.

Pump rate information provided by LakeCoal indicates that the two existing underground dewatering pumps from the Great Northern Seam sump have a maximum pumping rate of 72 L/sec and 64 L/sec respectively. This equates to a total maximum pumping rate from underground of approximately 11.75 ML/day. However, within 12 months of the Proposal being approved LakeCoal is committed to limiting the main underground pumps to a maximum pump out rate of 10.5 ML/day (equivalent to the predicted average daily volume that will need to be pumped from the coal face during the later stages of the Proposal). The proposed timing of this commitment’s implementation is dictated by the substantial upgrades required to fully automate the pumps and have them controlled by a SCADA system.

It is noted that a number of storages exist in both the Great Northern and Wallarah Seams. As such, it would be possible to turn these pumps off during periods of high rainfall in order to stay within the LDP discharge limit of 12.161 ML/day. This is further discussed in **Section 6.2.1**.

### 5.3.4 Sedimentation Pond Characteristics

Information pertaining to the GoldSim modelling of the sedimentation ponds was obtained from survey data supplied by LakeCoal. This information is shown in **Table 10**. It should be noted that the volume of Pond D6 was not available and was estimated based on a 1m depth, the surface area and standard stage/storage relationships. Ponds D1 to D6 and D7 to D13 were each modelled as single storages to simplify the water balance processes at the Site.

**Table 10 – Sedimentation Pond Parameters**

Pond	Surface Area (m <sup>2</sup> )	Volume (m <sup>3</sup> )
D1	201	80
D2	178	51
D3	317	284
D4	1153	547
D5	726	770
D6	568	568 <sup>1</sup>
<b>Total Ponds D1 to D6</b>	<b>3143</b>	<b>2300</b>
D7	3323	3856
D8	3423	2933
D9	3287	3796
D10	3707	4802
D11	391	297
D12	523	229
D13	370	168
<b>Total Ponds D7 to D13</b>	<b>15 024</b>	<b>16 081</b>

1. Calculated using surface area and assumptions from LakeCoal based on site observations.

### 5.3.5 Loss of Water through Coal Export

During mining and conveying, the moisture content in the coal increases due to the use of water sprays at the coal face and at transfer points along the conveyor system. A review of the Colliery's coal analysis data indicates that the inherent (air dried) moisture content of the coal from underground is approximately 2.7%. This same data indicates that the total moisture of the Colliery's coal that is exported from the Colliery is approximately 7.3% which means that around 4.6% of this total moisture content is added to the coal prior to export. This equates to 69,000 tonnes of additional water at the proposed maximum rate of production of 1.5 Mtpa. Therefore, approximately 69.0 ML of water is exported from the Colliery every year, or 188.9 kL/day.

### 5.3.6 Additional Data Supplied by LakeCoal

A limited amount of water usage and flow monitoring data at Colliery was available for this water balance investigation. However, where historic information was lacking, data and operational information was made available to best derive estimates of the respective water balance parameters (flow rates, water usage, etc.). Additional data supplied by LakeCoal, as used in the water balance model, is shown in **Table 11**, as well as comments/assumptions on how this data was derived.

**Table 11 – Supplied and Derived Data**

Parameter	Value	Comments/Assumptions
Potable Water: Underground (includes increase of 25% to account for any additional underground potable water demand)	139.583 ML/yr	Average of underground potable water from March and April 2012 (monitored water use) with an additional 25% to account for increased potable water used underground as a result of the Proposal.
Potable Water: Main Office	211 L/day	Includes shower, sink and toilet facilities. Shower (26 L/day): Assumes 9L/min, 10 min/person, 2 showers per week. Toilet (154 L/day): Assumes 12 employees, employees at work 5 days/week, 6 L/toilet flush, average employee flushes 3 times/day (at work). Sink (31 L/day): Assumes 12 employees, 1.2 L/wash, employees at work 5 days/week, employees use sink 3 times/day.
Potable Water: Workshop	3724 L/day	Includes equipment washdown and sink use. Equipment Washdown (3712 L/day): Assumes 1 hour wash/day, 1.031 L/sec flow rate. Sink (12 L/day): Assumes 1.2 L/wash, 1 sink used 10 times per day.
Potable Water: Old Bath House	24 L/day	Includes sinks facilities. Sinks (24 L/day): Assumes 1.2 L/wash, 2 sinks each used 10 times per day.
Potable Water: New Bath House (Showers, Sink)	8519 L/day	Includes shower and sink facilities (assumes rainwater tank water used for toilets flushing). Shower (8190 L/day): Assumes 9L/min, 10 min/person, average of 91 shift ends / day (calculated from shift information provided by LakeCoal). Sink (329 L/day): Assumes 160 employees, 1.2 L/wash, employees at work 4 days/week, employees use sink 3 times/day.
Potable Water: Conveyor Washdown	11.135 kL/day	Assumes it is used 3 hrs/day, 1.031 L/s flow rate.
Bootwash Water Demand	273 L/day	Assumes it is used 3 L/person/shift, average of 91 shift ends / day (calculated from shift information provided by LakeCoal).
New Bath House Toilet Flushing Demand	1097 L/day	Assumes 160 employees, employees at work 4 days/week, 4 L/toilet flush (reduced for urinals), average employee flushes 3 times/day (at work).
Dust Suppression Demand	11.28 ML/yr	Calculated from available water cart records (3/01/2012 to 11/05/2012).
Combined Rainwater Tank Capacity	30 kL	Proposed rainwater tank capacity from discussions with LakeCoal and commitments made in the WMP.

## 5.4 Water Balance Results

### 5.4.1 Expected Discharge from the Colliery

The probabilistic GoldSim simulation indicated that when applying the historic variation in pumping rates from underground to the predicted 'worst case' average of 10.5 ML/day, the corresponding 95<sup>th</sup> percentile average daily discharge volume of 13.171 ML/day (including pit top runoff) exceeds the daily discharge limit of 12.161 ML/day. The greatest volume calculated in GoldSim using this probabilistic analysis was 14.394 ML/day.

However, as noted in **Section 5.3.3**, LakeCoal is committed to limiting the main underground pumps to a maximum pump out rate of 10.5 ML/day within 12 months of the Proposal being approved. As such, the GoldSim model was run (using a deterministic simulation) assuming that the pumps from the Great Northern Seam sump were constantly pumping at this 10.5 ML/day rate. This scenario assumes that adequate capacity is available in the underground workings to effectively store water during periods when the groundwater inflow rate exceeds the underground dewatering rate. This is further discussed in **Section 6.2.1**. It should be noted that assuming a constant underground pump rate of 10.5 ML/day is a 'worst case' scenario and is only predicted to occur, on occasions, near the end of the Proposal's life.

The daily discharge through LDP1 predicted by GoldSim assuming a constant underground pumping rate of 10.5 ML/day is shown in **Figure 5.5**.

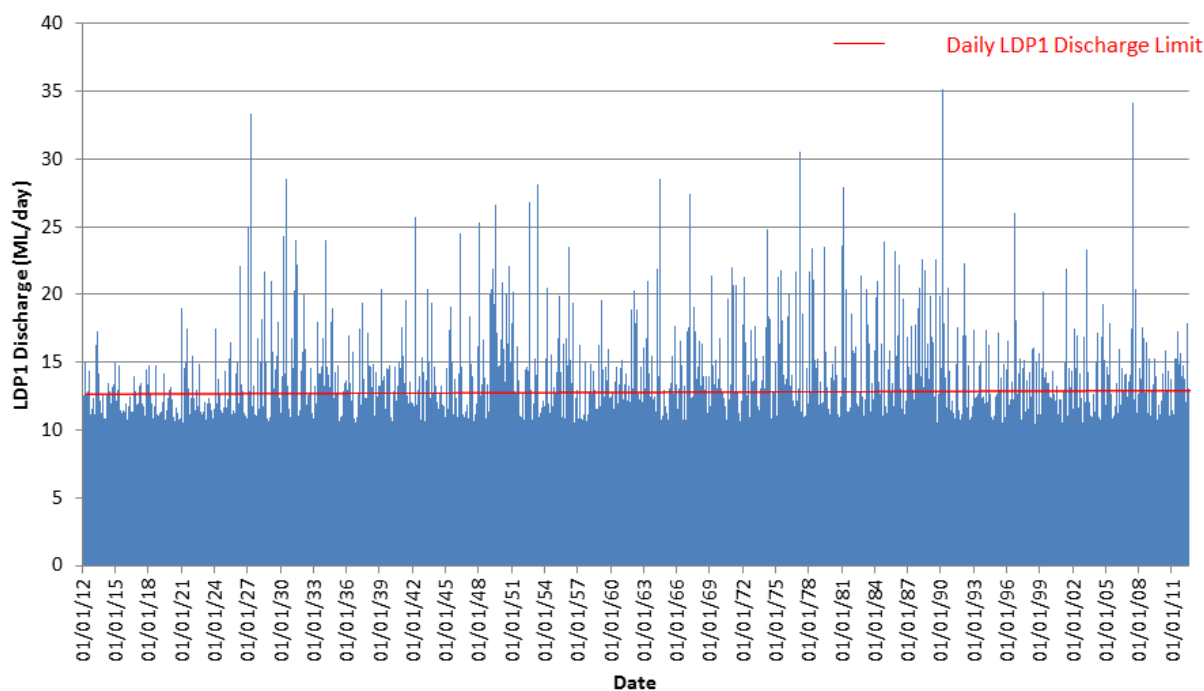

**Figure 5.5 – LDP1 Discharge Results Assuming Constant Maximum Pumping Rate from Underground**

The results shown in **Figure 5.5** indicate that if water make from underground is constantly pumped to the surface at 10.5 ML/day then exceedances of the LDP1 limit of 12.161 ML/day will occur regularly.

Key statistics from this GoldSim modelling, assuming a constant discharge from underground of 10.5 ML/day, include:

- Daily average discharge through the LDP1 of 10.716 ML/day;

- Maximum discharge through LDP1 of 35.124 ML/day; and
- Likelihood of LDP1 exceedance on any given day of 4% (or approximately 15 times per year).

These results indicate that underground storages within the Great Northern and Wallarah Seams are required to mitigate peak groundwater inflow rates. In addition, the results indicate that additional storm surge storage capacity is required at the pit top area to effectively mitigate peak runoff flow rates during large rainfall events, even when no pumping from underground occurs during such an event. These issues are further described in **Section 6.2.2**.

#### **5.4.2 Potable Water Use**

The total amount of potable water used at the colliery was investigated in the GoldSim model, with and without the committed water savings measures (as described in **Sections 4.2.1**) in order to quantify how much potable water these measures are likely to save at the site. GoldSim modelling estimates that the potable water used in the pit top area will be reduced from 55.9 kL/day to 23.7 kL/day with an overall saving of 32.3 kL/day (11.8 ML/year) as a result of water saving measures being implemented.

This equates to an approximate reduction in total potable water of 8.9% (for current levels of potable water use) and 7.4% (allowing for a 25% increase in the underground potable water use as a result of the proposed future mining works).

## 6.0 SURFACE WATER IMPACTS AND PROPOSED MANAGEMENT MEASURES

The following section outlines the anticipated surface water impacts associated with the Proposal, and the proposed surface water management measures to be implemented at the Colliery. The Proposal includes only minor upgrades and modifications to surface infrastructure within the Colliery's pit top area. The Proposal's greatest potential to impact on surface water is from the increased water make expected from the proposed extension of underground mining activities. Therefore, management predominately focussed on this element of the Proposal.

### 6.1 Objectives

The key objectives of surface water management at the Colliery, as addressed in this SWA, are:

- the prevention of the flow of pollutants into watercourses and the sedimentation on receiving waters, being Swindles Creek to the east of the pit top and Lake Macquarie;
- the control of discharges from the site to ensure that all discharges are within the water volume and quality criteria set out in EPL 1770;
- to minimise site potable water usage requirements and maximise runoff water reuse; and
- to ensure there is sufficient water available to meet the Colliery's water requirements.

### 6.2 Water Discharge Quantity Management

#### 6.2.1 Pit Top Area including Pumping from Underground

The water balance model demonstrated that with a constant pumping rate from underground of 10.5 ML/day (equivalent to the predicted average daily volume that will need to be pumped from the coal face during the later stages of the Proposal) the Colliery has the potential to exceed the 12.161 ML/day LDP1 discharge limit approximately 4% of the time (equivalent to 15 days per year). As such, it is proposed to utilise the existing underground storages to store excess water in order to reduce the number of potential exceedances of the discharge volume limit. Using underground storages for water management is common practice in Hunter Valley coal mines and is already undertaken at the Site to a certain extent.

LakeCoal has indicated to GSSE that operationally the Colliery can store approximately 3 to 4 weeks worth of groundwater within the Wallarah and Great Northern Seams. This equates to somewhere between 255 to 305 ML of storage capacity (as shown in the draft 'Water Storage & Pump Lines Schematic' provided by LakeCoal) that could be used to store groundwater during periods of wet weather or to attenuate pumping requirements during periods of excess groundwater inflow towards the end of the Proposal's life. If operated and managed effectively it is considered that this amount of underground storage will be sufficient to adequately manage the predicted increase in water make expected as a result of the Proposal. It is recommended that an investigation into the actual available underground storage capacity be undertaken due to the importance of this storage in regards to the management of water during the life of the Proposal.

As discussed in **Section 5.3.3**, LakeCoal is committed to limiting the main underground pumps to a maximum pump out rate of 10.5 ML/day. As a result of this commitment and the utilisation of the underground storages the Proposal is not expected to increase the existing flow rates pumped to the pit top area from the main Great Northern Seam sump. As such, the Proposal is not expected to have any negative impacts on the surrounding environment, including cumulative impacts, long term

impacts and impacts to riparian corridors and creeklines. In addition, all mine water extraction will be measured daily and daily discharge volumes will be reported publically on a monthly basis via LakeCoal's website.

## 6.2.2 Storm Surge Capacity in Sedimentation Ponds

Although the Proposal is not expected to have any negative impacts on the surrounding environment, the GoldSim water balance undertaken for the Proposal did indicate that additional pond storage capacity or an amendment to EPL 1770 is currently required in the pit top area to adequately manage peak runoff flow rates during large rainfall events. These findings are different from those made during the AECOM (2011) water balance which was only based on annualised runoff volumes and did not take short term, high intensity, rainfall spikes into consideration.

Due to the regular pumping from underground and no existing procedures relating to the active dewatering of the sedimentation ponds, the Colliery does not appear to have sufficient storm surge capacity to mitigate peak runoff flow rates from the pit top area in order to comply with the 12.161 ML/day daily discharge limit at LDP 1. This lack of 'available' storage within the ponds is generally only considered to be an issue regarding the daily discharge limit volume and is not believed to be a significant water quality issue, primarily because the runoff from the pit top area is generally considered to be of a better quality compared to the water make from underground. Further the predicted frequency of this occurring is predicted to be approximately 15 times per year when the pump rate from the underground workings is limited to 10.5 ML/day.

As described in **Section 3.5.1**, it is believed that the 12.161 ML/day daily discharge limit was initially set with no consideration given to surface water runoff volumes. Assuming a maximum pumping rate from underground of 10.5 ML/day (as committed to by LakeCoal as part of this Proposal), calculations within the GoldSim water balance model indicate that the 12.161 ML/day daily discharge limit at LDP 1 would be adhered to for a 17mm rainfall event over a 24 hour duration. Therefore, as part of the Proposal LakeCoal will seek an amendment to EPL 1770 to include a condition on the daily discharge volume limit stating that:

*'Exceedance of the volume limit for Point 1 is permitted only if the discharge from Point 1 occurs solely as a result of rainfall at the premises exceeding 10mm during the 24 hours immediately prior to commencement of the discharge'.*

This proposed amendment to the EPL would resolve the issues associated with the lack of 'available' storage within the ponds and allows for the relative accuracy and assumptions made with regards to runoff volumes from the pit top area. EPL conditions such as the condition proposed above are not uncommon in the Lake Macquarie region with both Mandalong and Mannering mines containing similar conditions within their respective EPLs.

## 6.3 Water Quality Management

An assessment of the potential impact of the Proposal on the water quality of the downstream receiving waters (including Lake Macquarie) primarily relates to the expected quality of groundwater make as a result of the proposed mining operations. Water inflow from a dyke in the Fassifern Seam is relatively fresh to brackish, but inflows from the Wallarah and Great Northern Seams have salinity levels similar to seawater, indicating a hydraulic connection (albeit through an indirect pathway) to Lake Macquarie.

The Groundwater Assessment predicted that the overall water inflow quality into the proposed Fassifern Seam workings will be similar to the existing water quality. If the fracturing in the proposed, previously un-mined areas does not create a hydraulic connection with the Lake (as predicted in the Subsidence Impact Assessment, Ditton 2012) then the Proposal may result in an improvement to the underground water quality by diluting the current Wallarah and Great Northern Seam inflows.

However, LakeCoal has identified that the majority of the groundwater make comes from the Wallarah and Great Northern Seams and therefore freshening of the groundwater is unlikely.

Since the water make from underground is not expected to change in regards to both peak flow rates (refer to **Section 6.2**) and water quality, the Proposal is not expected to have any detrimental impacts to the surrounding environment, including cumulative impacts, long term impacts and impacts to riparian corridors and creeklines. Reference should be made to the existing surface water quality described in **Section 3.5.2** and the WMP (**Appendix B**). It is recommended that:

- more extensive baseline water quality data be collected to aid the development of appropriate pollutant trigger values (refer to Sections 8.2 and 8.3); and
- LakeCoal engage a suitably qualified expert to conduct an assessment of the metals contained within discharge water in accordance with the ANZECC water quality guidelines and issue this assessment to the EPA by the 31<sup>st</sup> December 2013.

## 6.4 Erosion and Sediment Control Structures

A number of improvements to ESC structures will be implemented in accordance with the WMP (refer to **Appendix B**), however these improvements are unrelated to managing potential impacts arising from the current Proposal. Since no changes to runoff regimes at the pit top area are anticipated as a result of the Proposal, no additional ESC structures are required in this area to facilitate the proposed underground mining works.

In accordance with the DGRs, should trucks continue to be used for coal haulage, LakeCoal will upgrade the truck washing facilities at the pit top area including capability to wash wheels and under the body of vehicles leaving the premises. As discussed in **Section 3.5.1**, the Colliery are also committed to rectifying issues relating to LDP1 including the currently un-metered discharge from site and seepage along the external dam wall that surrounds Pond D10.

## 6.5 Potable Water Management

Since the introduction of the miniwall mining method, the demand for potable water in underground operations has increased. An additional amount of potable water used in the underground operations is therefore likely due to the Proposal. From discussions with LakeCoal, it was estimated that this increase could be as high as 25%. Although this increase was incorporated into the site water balance (**Section 5.0**), it should be noted that this increase is very much an upper limit estimate and is considered conservative for the proposed works at the Colliery.

Potable water is an increasingly valuable and scarce resource and stakeholder concerns have been raised regarding the volume of potable water being consumed on-site. Therefore, LakeCoal is committed to trying to minimise their potable water use at the site. As part of the EA (AECOM, 2011), LakeCoal made a number of commitments including the installation of rainwater tanks on two buildings at the pit top area. These rainwater tanks, which would collect runoff from the workshop and old bath house roof areas as described in **Section 5.0**, were included in the water balance investigation.

LakeCoal also intend on reducing the potable water consumption at the site by drawing water from the sedimentation ponds to use on-site for dust suppression purposes. LakeCoal has indicated that Pond D6 is practically the most appropriate pond to draw the water from, although the surrounding ponds D1-D5 could also be used if required. This water use for dust suppression purposes was also included in the water balance modelling of the site.

As discussed in **Section 5.4.2**, the site water balance investigated the total amount of potable water used at the Colliery, with and without the water savings measures described above. The water

balance model estimated that the potable water used in the pit top area will be reduced from 55.9 kL/day to 23.7 kL/day with an overall saving of 32.3 kL/day (11.8 ML/year) as a result of these water saving measures.

Since the potable water used underground is much higher than the potable water used in the pit top area (approximately 85% of the total potable water use) a reduction of the potable water used in the underground mining operations will have more of an effect on the overall potable water used at the site. Underground potable water saving measures should be investigated to minimise the amount of potable water required from Wyong Council. Environmentally feasible alternative water sources will also be investigated by LakeCoal, with investigations being undertaken to source water from the Mannering Park Sewerage Treatment Plant (STP) following Reverse Osmosis (RO) treatment by Vales Point Power Station. However, currently all available water is consumed in the Vales Point Power Station operations.

## 7.0 SITE WATER MANAGEMENT PLAN

The Colliery's existing WMP, prepared in accordance with the requirements of Conditions 28 to 33 Schedule 3 of Project Approval MP 10\_0161, was completed by GSSE in August 2012, in consultation with NOW, Division of Resources and Energy, the Department of Trade and Investment, Regional Infrastructure and Services and Wyong Shire Council, This WMP has been provided in **Appendix B** and incorporates:

- An existing site Water Balance;
- An Erosion and Sediment Control Plan;
- A Surface Water Management Plan;
- A Groundwater Monitoring Program; and
- A Surface and Ground Water Response Plan.

The site water balance presented in the existing WMP is a summary of the water balance completed for the Colliery's existing operations (AECOM, 2011). This water balance has been updated for this SWA and is presented in **Section 5.0**.

The Erosion and Sediment Control Plan (ESCP) was developed to minimise soil erosion and the potential discharge of sediment to downstream waters during mining. It recommends ESC Structures (refer to **Appendix B**) in accordance with best management practices and the requirements of Managing Urban Stormwater: Soils and Construction (the Blue Book), Volume 1 and Volume 2E – Mines and Quarries (Landcom, 2004 and Department of Environment and Climate Change (DECC), 2008).

The WMP also outlines the water management currently undertaken at the Colliery and documents potential methods for minimising potable water consumption, increased recycled water use, and improved management of surface rainfall runoff and wastewater; and includes a detailed monitoring program for both surface and underground waters. These programs include a method for the development and maintenance of baseline water quality data, a review of site appropriate assessment criteria and a program to monitor mining related impacts on the receiving environment.

A review of the existing WMP will be undertaken in line with the findings of this SWA should the Proposal be approved, with further updates to be undertaken on the basis of operational experience, monitoring results and the determination of site discharge assessment criteria

## 8.0 SURFACE WATER MONITORING PROGRAM

### 8.1 Introduction

A Surface Water Monitoring Program (SWMP) was completed by GSSE in August 2012 as part of the Colliery's WMP. This SWMP was developed to ensure the continued functionality of the surface water management system and to assist LakeCoal in identifying any potential issues with the system. It was prepared in accordance with Schedule 3, Condition 31 of MP10\_0161 and includes:

- baseline data on surface water flows;
- surface water impact assessment criteria;
- a program to monitor the impact of the project approval under MP10\_0161 on surface water flows and quality; and
- procedures for reporting the results of this monitoring.

The Proposal is not expected to require changes or upgrades to the existing surface water management structures, i.e. with the exception of potential methods to increase the storm surge capacity at the pit top area and the provision of new truck washing facilities, if required. As such, the SWMP detailed in the WMP is still applicable to the Proposal and is summarised in the following sections.

### 8.2 Baseline Data

The baseline water quality data available for the site is presented in **Section 3.5.2**. The amount of baseline data available is limited, as no baseline water quality data was collected prior to the previous project application. Since 2008 regular water quality samples have been taken from LDP 1 and since September 2011 this sampling was expanded to include upstream and downstream monitoring.

### 8.3 Surface Water Impact Assessment Criteria and Trigger Levels

The Colliery is in the process of collecting baseline water quality monitoring data, for parameters documented in EPL 1770, with the view of determining site-appropriate trigger values for discharges at the LDP. The Australian Government's *National Water Quality Management Strategy* outlines the procedure for establishing water quality trigger values. The strategy suggests that a minimum of two years of continuous monthly data at a reference site is required for a valid, site-appropriate trigger to be established. During the collection of this baseline data, water quality data is assessed to determine if it is generally in accordance with (ANZECC 2000) 'trigger' values.

When considering assessment criteria and trigger levels, it is important to note that historic industrial activities and catchment development within Lake Macquarie have resulted in significant heavy metal contamination of the Lake Macquarie waters and sediments. Sediments on the seabed of Lake Macquarie have been found to contain elevated concentrations of cadmium, lead, mercury, selenium, silver and zinc, with the greatest contamination found near the power stations in the northern areas of the Lake (Roach, 2005). Sediments sampled from the southern areas, including Chain Valley Bay, have also reported concentrations significantly above background levels, indicating lake-wide contamination. Arsenic and copper concentrations have also been identified at elevated concentrations in sediments throughout the Lake, suggesting impacts typical of diffuse sources (Roach, 2005). Additionally, with the industry located upstream of LDP 1, including the sewerage works and Mannering Colliery, specific trigger values for heavy metal concentrations cannot be prescribed until such time that site-appropriate trigger values are established.

As recommended by the above *National Water Quality Management Strategy*, exceedances of the ANZECC (2000) trigger values should be taken as an 'early warning' mechanism to alert managers of

a potential impact which may require mitigation. Until such time as appropriate trigger levels are established, exceedances of the ANZECC (2000) trigger values, with the exception of metals, will result in an investigation being undertaken into the source of the exceedance. Monitoring values for metals shall be investigated if the analysis reveals a value of two standard deviations from the mean of the historical monitoring data from August 2011. Assuming normal distribution, two standard deviations from the mean will account for 95% of the range of historical values. This value will become more appropriate as monitoring continues.

The Colliery's response plan is contained within the WMP provided in **Appendix B**. This plan states that following notifications of an incident, site personnel at Chain Valley will immediately focus on the mitigation of any potential environmental harm. Should potential or actual harm to the environment be identified, the appropriate regulatory authority (ARA) shall be immediately notified and remediation measures applied. Where ameliorative actions may reduce the threat or harm to the environment, action will be undertaken immediately to mitigate or rectify the issue. These actions will be followed by an investigation into the cause of the incident.

**Table 12** provides a list of trigger values already utilised by the Colliery in addition to the pH and TSS limits within EPL 1770. These values typically represent the 95% marine protection values from the ANZECC water quality guidelines.

**Table 12 – Pollutant Trigger Values for Chain Valley Colliery**

Indicator	Trigger Value (µg/L)
<b>Other</b>	
Total phosphorus	30 (µg/L)
Total nitrogen	300 (µg/L)
Surfactant <sup>1</sup> (MBAS)	200 (µg/L)
<b>Biologicals</b>	
Faecal coliforms	Median < 1000 faecal coliforms per 100 mL, with 4 out of 5 samples < 4000/100 mL
Enterococci	Median < 230 Enterococci per 100 mL (maximum number in any one sample: 450-700 organisms/100 mL).

1. ANZECC guidelines for recreational purposes adopted.

## 8.4 Surface Water Monitoring and Frequency

The Colliery's existing water monitoring program is not expected to require amendment as a result of the Proposal. Water monitoring will continue to be undertaken in accordance with EPL1770 and the WMP, which includes monitoring of parameters and locations above and beyond those required by EPL 1770. The monitoring locations, pollutants to be monitored and the required frequency are detailed in **Table 13** with the position of these monitoring locations shown on **Figure 8.1**.

All monitoring of waters will be undertaken in accordance with *Approved Methods for Sampling and Analysis of Water Pollutants in NSW* (DECCW, March 2004). Additionally, pollutant concentration measurements will be reported in micrograms per litre (ug/L) and within ANZECC detection limits as required.



**LEGEND:**

 SURFACE WATER MONITORING SITE

0 50 100 150m  
Scale 1:2500

**FIGURE 8.1**

**SURFACE WATER MONITORING LOCATIONS**

Project:  
CHAIN VALLEY COLLIERY  
SURFACE WATER ASSESSMENT

Client:  
CHAIN VALLEY COLLIERY

File:  
Fg8.1\_EMG00-008\_Water\_Management\_System\_130206

Projection:  
GDA 94 MGA Zone 56

Version:	Date:	Author:	Checked:	Approved:
1	28/08/2012	MS	DB	AB
2	06/02/2013	LH	DB	AB



**Table 13 – EPL 1770 Surface Water Monitoring Locations and Frequency**

Identification	Type of Monitoring Point	Pollutants (µg/L) <sup>1</sup>	Frequency	Sampling Method
Dam 10 Outlet	Outlet of Final Sedimentation Dam	Aluminium (dissolved) Aluminium (total) Arsenic (dissolved) Arsenic (total) Beryllium (dissolved) Beryllium (total) Cadmium (dissolved) Cadmium (total) Chromium (dissolved) Chromium (total) Cobalt (dissolved) Cobalt (total) Conductivity (µS/cm) Copper (dissolved) Copper (total) Lead (dissolved) Lead (total) Mercury (dissolved) Mercury (total) Molybdenum (dissolved) Molybdenum (total) Nickel (dissolved) Nickel (total) Nitrogen (ammonia) pH (pH) Phosphorus (mg/L) Selenium (dissolved) Selenium (total) Silver (dissolved) Silver (total) Total suspended solids (mg/L) Vanadium (dissolved) Vanadium (total) Zinc (dissolved) Zinc (total) Anionic Surfactants as MBAS (mg/L) BOD <sup>5(2x)</sup> (mg/L) Faecal Coliforms <sup>(*)</sup> (cfu/100ml)  Enterococci <sup>(*)</sup> (cfu/100ml) Total Oil and Grease (mg/L)	Monthly (min 4 weeks)	Grab sample
LDP1	Licensed Discharge Point			
USSP	Baseline Data (Upstream of Site)			
RW1	Baseline Data (Downstream of Site)			
Lake Macquarie	Water Quality	Temperature (°C) pH (pH) Turbidity (NTU) Dissolved Oxygen (%) Total phosphorus (mg/L) Total nitrogen (mg/L)	Six Monthly	In Situ In Situ In Situ In Situ Grab sample Grab sample
AWTS Effluent Stream	Water Quality	Total suspended solids (mg/L) Total Dissolved solids (mg/L)	Quarterly	Grab sample Grab sample

Identification	Type of Monitoring Point	Pollutants (µg/L) <sup>1</sup>	Frequency	Sampling Method
		Total phosphorus (mg/L) Total nitrogen (mg/L) Total Oil and Grease (mg/L) BOD <sup>5(2)</sup> (mg/L) pH (pH) Faecal Coliforms (cfu/100ml) SAR (√ me/L)		Grab sample Grab sample Grab sample Grab sample Grab sample Grab sample Grab sample

1. Pollutant concentration measurements will be determined in micrograms per litre and within ANZECC concentration limits unless noted otherwise.
  2. BOD<sup>5</sup> – 5 day Biological Oxygen Demand.
- \* These values are specifically for monitoring effluent, if effluent is not irrigated or discharged they would not be required.

## 8.5 Additional Operational Monitoring

In addition to the required monitoring described in **Section 8.4**, additional monitoring is undertaken by the Colliery as described below.

### 8.5.1 Effluent Monitoring

Currently, the classification and quantity of effluent from the AWTS and septic water treatment systems is unknown. Additionally, the characteristics of the soils receiving the effluent through irrigation are also unknown. Both of these properties are required to determine the appropriate management targets and practices. **Table 13** outlines the monitoring parameters required for the effluent stream and **Table 14** outlines the monitoring parameters required for assessing the characteristics of the soils. The *Environmental Guidelines use of Effluent by Irrigation, Department of Environment and Conservation*, nominate weekly monitoring for faecal coliforms. However, if the effluent stream reveals a low number of faecal coliforms, as is the case with the administration effluent stream, quarterly monitoring is appropriate.

Currently, it is assumed that the effluent being disposed of through irrigation, is being applied to an appropriate area, However, once the effluent is characterised the appropriateness of the existing irrigation area can be determined.

**Table 14 – Recommended Soil Monitoring Strategy**

Constituent	Frequency of Sampling	
	Surface Soil	Soil Profile
pH	Annually	Annually
Electrical Conductivity EC (dS/m)	Annually	Annually
Nitrate-N	Annually	Annually
Total N	After 3 years	Every 3 years
Available P	Annually	N/a
Total P	After 3 years	Every 3 years
Exchangeable Sodium Percentage	Annually	Every 3 years
Heavy Metals & Pesticides	After 10 years	N/a
P sorption	After 3 years	Every 3 years

### 8.5.2 Stream Health Channel Flow and Riparian Vegetation Monitoring

A program to monitor creek line channel stability and the health of riparian vegetation within Swindles Creek to the east of the pit top area will be undertaken throughout the life of the mine, although no adverse impacts are expected associated with the Proposal. The monitoring will be undertaken along a short length of the downstream watercourse. General observations of stream health will be recorded during the quarterly water quality monitoring for this watercourses and comprise:

- Documenting general observations of water quantity and quality;
- Documenting locations and dimensions of significant erosive or depositional features so that any subsequent changes can be evaluated quantitatively;
- Establishing multiple photographic points at representative locations, so that photos can be taken over multiple inspections in a repeatable manner;
- Providing written descriptions of the stream at each of the photographic points, focussing on evidence of erosion and exposed soils; and
- Documenting general indicators of stream health, including abundance of flora and fauna.

Monitoring will be recorded on a specific field sheet to be developed and included within the WMP or Biodiversity Management Plan. Results of monitoring data will be reviewed and compared to previous rounds of monitoring to assess whether there is any degradation of the riparian vegetation or stream channel. Where degradation or adverse erosion is occurring, additional investigations will be undertaken to assess whether the impacts are associated with the operation of the mine and ameliorative actions undertaken as required.

Further stream health and riparian vegetation monitoring will be undertaken as part of the Biodiversity Management Plan (EMP-D-16372) which is typically undertaken as a random transect monitoring program. The recording of an elevated or abnormal result (where triggers outlined as part of the monitoring program are exceeded) may result in an investigation into the surface water components related to the result. For further information on trigger and response protocol refer to the colliery's WMP in **Appendix B**.

### 8.6 Reporting of Monitoring Data

Recording of monitoring data will be undertaken in accordance with the requirements outlined within the Colliery WMP and EPL 1770. LakeCoal will collate and maintain an up-to-date database of surface water quality monitoring data for all sampling at the Colliery inclusive of a hard copy (laboratory results) and an electronic (results) database. Monitoring results will be interpreted as they are received in order to ensure appropriate operational guidance on maintaining water quality within the desired parameters.

The results will also be assessed in terms of relevant site operations and meteorological conditions to enhance further interpretation. This comparison between samples, sampling periods and against other factors will assist in identifying whether the activities at the Colliery are affecting the water quality of the local environment.

Results of surface water quality monitoring will be reported in the Annual Review. The results will also be made available to the Community Consultative Committee (CCC) on a regular basis as part of the environmental monitoring and reporting process, as well as to the Wyong Shire and Lake Macquarie City Councils.

In accordance with amendments to Section 148 of the *POEO Act*, EPL holders are required to publish monitoring data that has been collected as a result of a licence condition. To comply with this

amendment and as required under condition 11, schedule 5 of MP10\_0161, LakeCoal will continue to publish relevant monitoring data on their website within 14 days of obtaining the data.

## 9.0 CONCLUSION

This SWA has assessed the potential impacts to surface water from the Proposal in accordance with the DGRs. Given the minimal disturbance proposed to the surface areas, potential impacts to surface water are limited. The Proposal's greatest potential to impact on surface water is from the increased underground water make expected from the proposed extension of underground mining activities. Therefore, management predominately focussed on this element of the Proposal.

The Groundwater Assessment undertaken for this Proposal predicted that the average daily water volumes pumped from the coal face would increase from approximately 7.3 ML/day to 10.5 ML/day over the life of the Proposal, without any significant change to the quality of water extracted from the Fassifern Seam. The detailed 'daily time-step' water balance model developed in GoldSim utilised the results of the Groundwater Assessment and commitments made by LakeCoal regarding groundwater management. It indicated that a combination of underground storage utilisation, an amendment to the daily discharge volume condition within EPL 1770 and limiting the maximum daily pump rate to 10.5 ML/day is required to effectively manage water at the pit top area..

It is therefore proposed to utilise existing storage capacity in both the Wallarah and Great Northern Seams to mitigate the effects of peak groundwater inflow rates and significant rainfall events at the pit top area in order to reduce the potential for exceedance of the 12.161 ML/day LDP1 daily discharge limit. LakeCoal have indicated that these seams have a combined storage capacity of approximately 3-4 weeks (based on a 10.5 ML/day inflow) which GSSE believes is sufficient to adequately manage the predicted increase in water make expected as a result of the Proposal.

The water balance also estimated that the potable water used in the pit top area may be reduced by 32.3 kL/day (11.8 ML/year) as a result of proposed water saving measures at the Colliery, including the use of rainwater tanks and the reuse of water within the sedimentation ponds for dust suppression purposes.

As a result of the SWA, including the site water balance, a number of recommendations have been identified including the below.

- Investigate the actual available underground storage capacity should be due to the importance of this storage in regards to the management of water during the life of the Proposal;
- Seek an amendment to EPL 1770 to include a condition that allows exceedances of the daily discharge volume limit when 10mm of rainfall has fallen on the premises within the preceding 24 hours.
- Limit the maximum pump out rate from underground to 10.5 ML/day, within 12 months of the Proposal being approved, in order to adhere to aforementioned proposed EPL amendment. The timing of this commitment is due to the substantial upgrades involved with fully automating the pumps and having them controlled by a SCADA system.
- Collect more extensive baseline water quality data to aid the development of appropriate pollutant trigger values.
- Engage a suitably qualified expert to conduct an assessment of the metals contained within discharge water in accordance with the ANZECC water quality guidelines and issue this assessment to the EPA by the 31<sup>st</sup> December 2013.

No adverse impacts to the surrounding environment are expected as a result of the Proposal since the water make from underground is not expected to change in terms of either discharge flow rates (i.e. quantity) or water quality.

## 10.0 REFERENCES

AECOM (2011) – *Environmental Assessment, Chain Valley Colliery Domains 1 and 2 Continuation Project*

AECOM (2011) – *Mine Water Balance. Chain Valley Continuations of Mining*, prepared for LakeCoal.

ANZECC (2000) - Australian and New Zealand Guidelines for Fresh and Marine *Water Quality*.

Australian Government's National Water Quality Management Strategy

Bureau of Meteorology (2012) – Evaporation data for weather station 61351 (Peats Ridge (Waratah Road))

Bureau of Meteorology (2012) – Rainfall data for weather station 61366 (Norah Head AWS)

Bureau of Meteorology (2012) – Rainfall data for weather station 61082 (Wyee (Wyee Farms Road))

Department of Environment and Climate Change (DECC) (2008) - *Managing Urban Stormwater: Soils and Construction – Volume 2E Mines and Quarries*, (the Blue Book Volume 2E)

*Department of Environment and Conservation, Approved Methods for the Sampling and Analysis of Water Pollutants in NSW, March 2004*

*Environmental Guidelines use of Effluent by Irrigation, Department of Environment and Conservation (NSW), 2004;*

Environmental Planning and Assessment Act 1979;

Environmental Protection Authority of New South Wales (2011) - *Environmental Protection License 1770*.

Geoterra (2012) – *Chain Valley Colliery Mine Extension 1 Project, Groundwater Assessment*

GSS Environmental (2012) - *Chain Valley Colliery Water Management Plan, Management System Plan*.

GSS Environmental (2011) – *Construction Soil and Water Management Plan for Ventilation Fan Upgrade*

Institution of Engineers Australia (1998) - *Australian Rainfall and Runoff*

LakeCoal (2012) – Coal analysis data

LakeCoal (2012) – Employee shift work records

LakeCoal (2012) – Historic pump flow and water usage spreadsheets

LakeCoal (2008) – *Mine Operation Plan 2008 - 2015*

LakeCoal (2012) – Water cart usage records

LakeCoal (2012) – Water quality database March 2012 spreadsheet

Landcom (2004) - *Managing Urban Stormwater: Soils and Construction – Volume 1, 4<sup>th</sup> Edition*, (the Blue Book Volume 1).

Mining Act 1992

*NSW Farm Dams Policy*

*NSW State Rivers and Estuaries Policy*

*NSW Water Quality and River Flow Objectives, September 1999*

Pearson & Associates (2009) – *Contour/detail survey, settling ponds Chain Valley Colliery, Ruttleys Road, Chain Valley Bay*

Protection of the Environment Operations Act 1997

Roach, A.C, (2005) - *Assessment of metals in Sediments from Lake Macquarie, New South Wales, Australia, using normalisation models and sediment quality guidelines. Marine Environmental Research* 59, pp. 453-472.

Water Act 1912

Water Management Act 2000

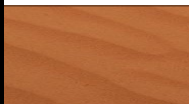

# APPENDIX A

## Appendix A

Table 21 – Baseline Site Water Quality LDP1 Oct 09 – Dec 10

Tested Pollutant	ANZECC (2000) Values (95%) Marine Environment	Water Quality Sample results from Sampling Point LDP1														Receiving Water Quality Results - Sept 2010		
		Oct-09	Nov-09	Dec-09	Jan-10	Feb-10	Mar-10	Apr-10	May-10	Jun-10	Jul-10	Aug-10	Sep-10	Oct-10	Nov-10	Dec-10	RW1 Chain Valley Bay	RW2 Marks Point
Total Oil and Grease Creek		<2		<2		5		<2	<2	3	<2							
Aluminium (total)	ID	350	510	380	310	720	510	480	560	520	890	370	550	1100	490	340	40	120
Aluminium (soluble)												170	190	67	290	110	<10	40
Ammonia as N	910 µg/L	<0.05	0.1	0.67	0.07	0.24	0.02	0.08	0.12	0.05	0.05	0.24	0.0019	0.017	0.045	<0.1		
Arsenic (total)		0.7	<0.05	0.7	0.9	<0.5	0.9	0.8	<0.5	<0.5	<0.5	<0.5	<0.5	<0.5	0.5	<0.5	<0.5	1.9
Arsenic (soluble)	ID											<0.5	<0.5	<0.5	<0.5	<0.5	<0.5	2
Beryllium (total)	ID											<1	<1	<1	<1	0.2	<0.1	<0.1
Beryllium (soluble)	ID											<1	<1	<1	<1	0.1	<0.1	<0.1
Boron	ID	273	268	255	266	730	264	253	234	238	388							
Cadmium (total)		<0.05	<0.05	<0.05	<0.05	<0.05	<0.05	<0.05	<0.05	<0.05	<0.05	<0.05	<1	<1	<1	<0.2	<0.2	0.4
Cadmium (soluble)	0.7 µg/L											<0.05	<1	<1	<1	<0.2	<0.2	0.4
Chromium (total)		<0.05	<0.05	<0.05	<0.05	<0.05	<0.05	<0.5	<0.05	<0.05	<0.05	<0.05	<2	<2	<2	<0.5	<0.5	<0.5
Chromium (soluble)	4.4 µg/L											<0.05	<2	<2	<2	<0.5	<0.5	<0.5
Cobalt (total)												7	<2	<2	<2	1.3	<0.2	<0.2
Cobalt (soluble)	1 µg/L											7	<2	<2	<2	1.3	<0.2	<0.2
Conductivity		18500	21800	19300	22600	27100	21200	21500	21400	13900	15300	17600	20900	20900	9500	12800		
Copper (total)		<0.05	<0.05	<0.05	<0.05	<0.05	<0.05	<0.05	<0.05	<0.05	<0.05	<0.05	3	0	3	<1	<1	4
Copper (soluble)	1.3 µg/L											<0.05	3	0	3	<1	<1	2
Lead (total)	4.4 µg/L	<0.05	<0.05	<0.05	<0.05	<0.05	<0.05	<0.05	<0.05	<0.05	<0.05	<0.05	2	3	2	0.4	<0.2	1.2

Review Date	Next Review Date	Revision No	Document Owner	Page
25/07/2012	25/07/2013	1	Environment and Community Coordinator	Page 76 of 93
<b>DOCUMENT UNCONTROLLED WHEN PRINTED</b>				

Tested Pollutant	ANZECC (2000) Values (95%) Marine Environment	Water Quality Sample results from Sampling Point LDP1														Receiving Water Quality Results - Sept 2010		
		Oct-09	Nov-09	Dec-09	Jan-10	Feb-10	Mar-10	Apr-10	May-10	Jun-10	Jul-10	Aug-10	Sep-10	Oct-10	Nov-10	Dec-10	RW1 Chain Valley Bay	RW2 Marks Point
Lead (soluble)												<0.05	2	3	2	<0.2	<0.2	0.4
Manganese	ID	<0.05	<0.05	0.13	<0.05	0.06	<0.05	0.05	0.06	0.05	0.1							
Mercury (total)		<0.5	<0.5	<0.5	<0.5	<0.5	<0.5	<0.5	<0.5	<0.5	<0.5	<0.5	<0.5	1.1	<0.5	<0.0001	<0.1	<0.1
Mercury (soluble)	0.1 µg/L											<0.5	<0.5	<0.5	<0.5	<0.0001	<0.1	<0.1
Molybdenum (total)	ID											19	9	8	4	3.4	2.4	12
Molybdenum (soluble)	ID											11	9	7	4	2.7	2.5	11.6
Nickel (total)		<0.05	<0.05	<0.05	<0.05	<0.05	<0.05	<0.05	<0.05	<0.05	<0.05	<0.05	2	<2	<2	5.6	0.8	0.7
Nickel (soluble)	7 µg/L											<0.05	2	<2	<2	4.5	<0.5	<0.5
pH		7.9	7.8	7.4	8	7.4	7.9	7.8	7.6	7.3	6.9	7.4	7.9	7.3	7.2	7.09		
Selenium (total)								<0.5	<0.5	<0.5	<0.5	<0.5	<0.5	<0.5	<0.5	2	<2	<2
Selenium (soluble)	ID											<0.5	<0.5	<0.5	<0.5	<2	<2	<2
Silver (total)								3	6	3	4	1	4	4	1	<0.1	<0.1	0.4
Silver (soluble)	1.4 µg/L											1	3	4	<1	<0.1	<0.1	0.1
Sus.Solids								17	8	16	14	14	12	15	6	<5		
Total Phosphorus	30 µg/L							<0.05	0.7	<0.05	<0.05	0.08	0.007	0.011	0.013	<0.01	40	80
Vanadium (total)												0.01	<0.01	<0.01	<0.01	<0.5	<0.5	1.6
Vanadium (soluble)	100 µg/L											0.02	<0.01	<0.01	<0.01	<0.5	<0.5	1.6
Zinc (total)								<0.05	<0.05	<0.05	<0.05	<0.05	10	9	11	13	15	19
Zinc (soluble)	15 µg/L											<0.05	10	9	11	10	8	18
Anionic Surfactants as MBAS																		
Faecal Coliforms																		

Review Date	Next Review Date	Revision No	Document Owner	Page
25/07/2012	25/07/2013	1	Environment and Community Coordinator	Page 77 of 93
<b>DOCUMENT UNCONTROLLED WHEN PRINTED</b>				

Table 22 – Baseline Site Water Quality LDP1 Jan 11 – March 12

Tested Pollutant	ANZECC (2000) Values (95%) Marine Environment	Water Quality Sample results from Sampling Point LDP1															Receiving Water Quality Results - Sept 2010	
		Jan-11	Feb-11	Mar-11	Apr-11	May-11	Jun-11	Jul-11	Aug-11	Sep-11	Oct-11	Nov-11	Dec-11	Jan-12	Feb-12	Mar-12	RW1 Chain Valley Bay	RW2 Marks Point
Aluminium (total)	ID	540	360	450	419	310	513	260	10	30	20	33	40	20	37	<10	40	120
Aluminium (soluble)		460	120	170	374	280	454	70	<10	20	<10	<25	<10	<10	<10	18	<10	40
Ammonia as N	910 µg/L	<0.1	<0.1	<0.1					<0.1	<0.1	<0.1	<0.10	<0.10	0.03	<0.10	<0.10		
Arsenic (total)		<0.5	<0.5	1.2	1	1	0.8	<0.5	<0.5	<0.5	<0.5	<1.0	1	1	<0.5	<0.5	<0.5	1.9
Arsenic (soluble)	ID	<0.5	<0.5	0.8	0.8	<0.5	0.8	<0.5	<0.5	<0.5	<0.5	<1.0	0.8	1	<0.5	<0.5	<0.5	2
Beryllium (total)	ID	0.1	<0.1	<0.1	0.2	<0.1	0.2	0.1	<0.1	<0.1	<0.1	<0.5	<0.1	<0.1	<0.1	<0.1	<0.1	<0.1
Beryllium (soluble)	ID	0.1	<0.1	<0.1	0.1	<0.1	0.2	<0.1	<0.1	<0.1	<0.1	<0.5	<0.1	<0.1	<0.1	<0.1	<0.1	<0.1
Cadmium (total)		<0.2	<0.2	<0.2	0.07	<0.2	<0.5	<0.2	<0.2	<0.2	<0.2	<0.26	<0.2	<0.2	<0.2	<0.2	<0.2	0.4
Cadmium (soluble)	0.7 µg/L	<0.2	<0.2	<0.2	0.07	<0.2	<0.05	<0.2	<0.2	<0.2	<0.2	<0.25	<0.2	<0.2	<0.2	<0.2	<0.2	0.4
Chromium (total)		<0.5	<0.5	<0.5	0.3	<0.5	0.4	<0.5	<0.5	<0.5	<0.5	<1.0	0.9	<0.5	0.6	<0.5	<0.5	<0.5
Chromium (soluble)	4.4 µg/L	<0.5	<0.5	<0.5	0.07	<0.5	0.6	<0.5	<0.5	<0.5	<0.5	<1.0	0.8	<0.5	<0.5	<0.5	<0.5	<0.5
Cobalt (total)		0.6	0.8	0.5	1	0.7	1.4	0.9	<0.2	<0.2	<0.2	<0.5	<0.2	<0.2	<0.2	<0.2	<0.2	<0.2
Cobalt (soluble)	1 µg/L	0.7	<0.5	0.5	1.1	0.6	1.2	1.2	<0.2	<0.2	<0.2	<0.5	<0.2	<0.2	<0.2	<0.2	<0.2	<0.2
Conductivity		12500	23400	28800	20900	24600	11400	20000	33900	33900	33901	33300	32700	33700	32100	32900		
Copper (total)		<1	<1	1	0.7	<1	1	1	<1	<1	<1	<2.6	<1	<1	<1	<1	<1	4
Copper (soluble)	1.3 µg/L	<1	<1	<1	0.6	0.6	1.4	1.2	<0.2	<1	<1	<2.5	<1	1	<1	<1	<1	2
Lead (total)		<0.2	<0.2	0.3	1.8	<0.2	0.7	0.3	0.4	<0.2	<0.2	<0.5	<0.2	<0.2	<0.2	<0.2	<0.2	1.2
Lead (soluble)	4.4 µg/L	<0.2	<0.2	<0.2	1.2	<0.2	0.6	<0.2	<0.2	<0.2	<0.2	<0.5	<0.2	<0.2	<0.2	<0.2	<0.2	0.4
Mercury (total)		<0.0001	<0.0001	<0.0001	<0.0001	<0.0001	<0.0001	<0.0001	<0.0001	<0.0001	<0.0001	<0.0001	<0.0001	<0.0001	<0.0001	<0.0001	<0.0001	<0.0001
Mercury (soluble)	0.1 µg/L	<0.0001	<0.0001	<0.0001	<0.0001	<0.0001	<0.0001	<0.0001	<0.0001	<0.0001	<0.0001	<0.0001	<0.0001	<0.0001	<0.0001	<0.0001	<0.0001	<0.0001
Molybdenum (total)	ID	8.2	10.7	24.2	6.1	16.9	5.2	13.2	2.1	1.6	2.1	2.3	2.5	3.1	0.8	2.5	2.4	12

Review Date	Next Review Date	Revision No	Document Owner	Page
25/07/2012	25/07/2013	1	Environment and Community Coordinator	Page 78 of 93
<b>DOCUMENT UNCONTROLLED WHEN PRINTED</b>				

Tested Pollutant	ANZECC (2000) Values (95%) Marine Environment	Water Quality Sample results from Sampling Point LDP1															Receiving Water Quality Results - Sept 2010	
		Jan-11	Feb-11	Mar-11	Apr-11	May-11	Jun-11	Jul-11	Aug-11	Sep-11	Oct-11	Nov-11	Dec-11	Jan-12	Feb-12	Mar-12	RW1 Chain Valley Bay	RW2 Marks Point
Molybdenum (soluble)	ID	6.1	11.3	24.3	5.7	15	4.8	13.2	<0.1	1.8	1.8	2.2	2.1	3.2	0.5	2.3	2.5	11.6
Nickel (total)	7 µg/L	7.8	6.4	9.1	7.6	8.5	6.6	7.8	1	<0.5	1.1	<2.6	0.6	0.6	1	<0.5	0.8	0.7
Nickel (soluble)		6.9	7.2	9.1	6.1	8.6	5.7	7.3	<0.5	<0.5	<0.5	<2.5	0.7	0.8	<0.5	0.5	<0.5	<0.5
pH		7.75	7.52	8	7.16	7.73	6.89	7.45	7.85	7.89	7.93	8.01	7.94	7.87	7.89	7.91		
Selenium (total)	ID	<2	<2	<2	0.3	<2	0.2	<2	<2	<2	<2	<1.0	<2	<2	<2	<2	<2	<2
Selenium (soluble)		<2	<2	<2	0.2	<2	<2	<2	<2	<2	<2	<2	<1.0	<2	<2	<2	<2	<2
Silver (total)	1.4 µg/L	<0.1	<0.1	<0.1	2.2	<0.1	0.2	<0.1	<0.1	<0.1	<0.1	<0.5	<0.1	<0.1	<0.1	<0.1	<0.1	0.4
Silver (soluble)		<0.1	<0.1	<0.1	1.4	<0.1	0.3	<0.1	<0.1	<0.1	<0.1	<0.5	<0.1	<0.1	<0.1	<0.1	<0.1	<0.1
Sus.Solids		<5	<5	<5	<5	<5	5	<5	5	<5	<5	10	<5	14	8	10		
Total Phosphorus	30 µg/L	<0.02	0.1	<0.1					<0.1	0.06	<0.01	<0.01	0.02	0.05	<0.01	<0.01	40	80
Vanadium (total)	100 µg/L	<0.5	<0.5	<0.5	0.8	<0.5	1.6	<0.5	<0.5	<0.5	<0.5	1.5	<0.5	<0.5	<0.5	<0.5	<0.5	1.6
Vanadium (soluble)		0.7	0.5	<0.5	0.8	<0.5	1.8	<0.5	<0.5	<0.5	<0.5	<1.0	<0.5	<0.5	<0.5	<0.5	<0.5	<0.5
Zinc (total)	15 µg/L	<5	10	10	10	10	27	14	14	17	11	13	16	29	32	17	15	19
Zinc (soluble)		6	<5	5	9	8	22	12	<5	12	8	8	43	24	11	14	8	18
Anionic Surfactants as MBAS									0.3		<0.1	<0.1	0.1	0.1	<0.1	0.1		
Faecal Coliforms									38		10	54	200	~2	760	~2		

Review Date	Next Review Date	Revision No	Document Owner	Page
25/07/2012	25/07/2013	1	Environment and Community Coordinator	Page 79 of 93
<b>DOCUMENT UNCONTROLLED WHEN PRINTED</b>				

Table 23 – Baseline Site Water Quality Dam 10 Outlet Nov 10 – July 11

Tested Pollutant	ANZECC (2000) Values (95%) Marine Environment	Water Quality Sample results from Sampling Point Dam 10 Outlet									Receiving Water Quality Results - Sept 2010	
		Nov-10	Dec-10	Jan-11	Feb-11	Mar-11	Apr-11	May-11	Jun-11	Jul-11	RW1 Chain Valley Bay	RW2 Marks Point
Aluminium (total)	ID	0.1	0.04	<0.01	0.1	0.05	40	60	70	80	40	120
Aluminium (soluble)		0.029	<0.01	<0.01	<0.1	0.04	40	80	80	20	<10	40
Ammonia as N	910 µg/L	0.1	<0.1		<0.1	<0.1						
Arsenic (total)		0.5	<0.5	<0.5	<0.5	<0.5	<0.5	<0.5	<0.5	<0.5	<0.5	1.9
Arsenic (soluble)	ID	<0.5	<0.5	<0.5	<0.5	<0.5	<0.5	<0.5	<0.5	<0.5	<0.5	2
Beryllium (total)	ID	<1	<0.1	<0.1	<0.1	<0.1	<0.1	<0.1	<0.1	<0.1	<0.1	<0.1
Beryllium (soluble)	ID	<1	<0.1	<0.1	<0.1	<0.1	<0.1	<0.1	<0.1	<0.1	<0.1	<0.1
Cadmium (total)		<1	<0.2	<0.2	<0.2	<0.2	<0.2	<0.2	<0.2	<0.2	<0.2	0.4
Cadmium (soluble)	0.7 µg/L	<1	<0.2	<0.2	<0.2	<0.2	<0.2	<0.2	0.2	<0.2	<0.2	0.4
Chromium (total)		<2	<0.5	<0.5	<0.5	<0.5	<0.5	<0.5	<0.5	<0.5	<0.5	<0.5
Chromium (soluble)	4.4 µg/L	<2	<0.5	<0.5	<0.5	<0.5	0.6	<0.5	<0.5	<0.5	<0.5	<0.5
Cobalt (total)		<2	<0.2	<0.2	<0.2	<0.2	<0.2	<0.2	<0.2	<0.2	<0.2	<0.2
Cobalt (soluble)	1 µg/L	<2	<0.2	<0.2	<0.2	<0.2	<0.2	<0.2	<0.2	<0.2	<0.2	<0.2
Conductivity		31300	35000	13200	33800	35100	33700	35300	36300	35000		
Copper (total)		3	<0.1	<0.1	<0.1	3	<1	<1	<1	<1	<1	4
Copper (soluble)	1.3 µg/L	3	<0.1	<0.1	<0.1	<0.1	<1	<1	<1	<1	<1	2
Lead (total)		5	0.3	<0.2	<0.2	0.6	<0.2	<0.2	0.3	<0.2	<0.2	1.2
Lead (soluble)	4.4 µg/L	6	<0.2	<0.2	<0.2	0.4	<0.2	0.4	0.2	<0.2	<0.2	0.4
Mercury (total)		<0.5	<0.0001	<0.0001	<0.0001	<0.0001	<0.0001	<0.0001	<0.0001	<0.0001	<0.1	<0.1
Mercury (soluble)	0.1 µg/L	<0.5	<0.0001	<0.0001	<0.0001	<0.0001	<0.0001	<0.0001	<0.0001	<0.0001	<0.1	<0.1
Molybdenum (total)	ID	2	1.9	1.1	2.1	1.9	1.1	2.7	2.2	2.6	2.4	12

Review Date	Next Review Date	Revision No	Document Owner	Page
25/07/2012	25/07/2013	1	Environment and Community Coordinator	Page 80 of 93
<b>DOCUMENT UNCONTROLLED WHEN PRINTED</b>				

Tested Pollutant	ANZECC (2000) Values (95%) Marine Environment	Water Quality Sample results from Sampling Point Dam 10 Outlet									Receiving Water Quality Results - Sept 2010	
		Nov-10	Dec-10	Jan-11	Feb-11	Mar-11	Apr-11	May-11	Jun-11	Jul-11	RW1 Chain Valley Bay	RW2 Marks Point
Molybdenum (soluble)	ID	2	2.8	1.3	3.2	2.2	1.6	1.3	1.5	2.6	2.5	11.6
Nickel (total)		<2	1.4	0.5	0.5	3.5	1.6	1.4	2.1	1	0.8	0.7
Nickel (soluble)	7 µg/L	<2	0.8	0.6	0.6	0.8	0.5	2.7	1.7	1.1	<0.5	<0.5
pH		7.8	7.95	7.96	7.9	8.01	7.73	7.9	7.82	7.89		
Selenium (total)		<0.5	<2	<2	<2	<2	<2	<2	<2	<2	<2	<2
Selenium (soluble)	ID	<0.5	<2	<2	<2	<2	<2	<2	<2	<2	<2	<2
Silver (total)		4	<0.1	<0.1	<0.1	<0.1	0.1	<0.1	<0.1	<0.1	<0.1	0.4
Silver (soluble)	1.4 µg/L	3	<0.1	<0.1	<0.1	<0.1	<0.1	<0.1	<0.1	<0.1	<0.1	0.1
Sus.Solids		19	<5	<5	21	<5	8	<5	<5	17		
Total Phosphorus	30 µg/L	0.008	<0.01	<0.01	0.04	0.02					40	80
Vanadium (total)		<0.01	<0.5	0.5	<0.5	<0.5	0.7	<0.5	<0.5	<0.5	<0.5	1.6
Vanadium (soluble)	100 µg/L	<0.01	5	0.5	<0.5	<0.5	<0.5	<0.5	<0.5	<0.5	<0.5	1.6
Zinc (total)		13	8	<5	10	33	9	13	35	24	15	19
Zinc (soluble)	15 µg/L	13	<5	<5	7	<5	9	16	28	18	8	18
Anionic Surfactants as MBAS												
Faecal Coliforms												

Review Date	Next Review Date	Revision No	Document Owner	Page
25/07/2012	25/07/2013	1	Environment and Community Coordinator	Page 81 of 93
<b>DOCUMENT UNCONTROLLED WHEN PRINTED</b>				

Table 24 – Baseline Site Water Quality Dam 10 Outlet August 11 – March 12

Tested Pollutant	ANZECC (2000) Values (95%) Marine Environment	Water Quality Sample results from Sampling Point Dam 10 Outlet								Receiving Water Quality Results - Sept 2010	
		Aug-11	Sep-11	Oct-11	Nov-11	Dec-11	Jan-12	Feb-12	Mar-12	RW1 Chain Valley Bay	RW2 Marks Point
Aluminium (total)	ID	10	20	50	36	90	20	<10	44	40	120
Aluminium (soluble)		2	30	<10	<25	<10	<10	<10	<10	<10	40
Ammonia as N	910 µg/L	<0.1	<0.1	<0.1	<0.1	<0.10	0.02	<0.10	<0.10		
Arsenic (total)		<0.5	<0.5	<0.5	<1.0	1.1	1.6	<0.5	<0.5	<0.5	1.9
Arsenic (soluble)	ID	<0.5	<0.5	<0.5	<1.0	1	1.4	<0.5	<0.5	<0.5	2
Beryllium (total)	ID	<0.1	<0.1	<0.1	<0.5	<0.1	<0.1	<0.1	<0.1	<0.1	<0.1
Beryllium (soluble)	ID	<0.1	<0.1	<0.1	<0.5	<0.1	<0.1	<0.1	<0.1	<0.1	<0.1
Cadmium (total)		<0.2	<0.2	<0.2	<0.26	<0.2	<0.2	<0.2	<0.2	<0.2	0.4
Cadmium (soluble)	0.7 µg/L	<0.2	<0.2	<0.2	<0.25	<0.2	<0.2	<0.2	<0.2	<0.2	0.4
Chromium (total)		<0.5	<0.5	<0.5	<1.0	0.7	<0.5	<0.5	<0.5	<0.5	<0.5
Chromium (soluble)	4.4 µg/L	<0.5	<0.5	<0.5	<1.0	0.7	<0.5	<0.5	<0.5	<0.5	<0.5
Cobalt (total)		<0.2	<0.2	<0.2	<0.5	<0.2	<0.2	<0.2	<0.2	<0.2	<0.2
Cobalt (soluble)	1 µg/L	<0.2	<0.2	<0.2	<0.5	<0.2	<0.2	<0.2	<0.2	<0.2	<0.2
Conductivity		33800	33900	34300	33400	33200	33400	32200	32600		
Copper (total)		<1	<1	<1	<2.6	<1	<1	<1	<1	<1	4
Copper (soluble)	1.3 µg/L	<1	<1	<1	<2.5	<1	<1	<1	1	<1	2
Lead (total)		0.4	<0.2	0.2	<0.5	<0.2	<0.2	<0.2	<0.2	<0.2	1.2
Lead (soluble)	4.4 µg/L	<0.2	<0.2	<0.2	<0.5	<0.2	<0.2	<0.2	0.3	<0.2	0.4
Mercury (total)		<0.0001	<0.0001	<0.0001	<0.0001	<0.0001	<0.0001	<0.0001	<0.0001	<0.1	<0.1
Mercury (soluble)	0.1 µg/L	<0.0001	<0.0001	<0.0001	<0.0001	<0.0001	<0.0001	<0.0001	<0.0001	<0.1	<0.1
Molybdenum (total)	ID	2.1	1.6	2	2.4	2.5	3	1.8	2.5	2.4	12
Molybdenum (soluble)	ID	<0.1	1.8	1.8	2.1	2.3	2.8	0.8	2.3	2.5	11.6

Review Date	Next Review Date	Revision No	Document Owner	Page
25/07/2012	25/07/2013	1	Environment and Community Coordinator	Page 82 of 93
<b>DOCUMENT UNCONTROLLED WHEN PRINTED</b>				

Tested Pollutant	ANZECC (2000) Values (95%) Marine Environment	Water Quality Sample results from Sampling Point Dam 10 Outlet								Receiving Water Quality Results - Sept 2010	
		Aug-11	Sep-11	Oct-11	Nov-11	Dec-11	Jan-12	Feb-12	Mar-12	RW1 Chain Valley Bay	RW2 Marks Point
Nickel (total)	7 µg/L	1	<0.5	1.3	<2.6	0.7	<0.5	0.6	0.5	0.8	0.7
Nickel (soluble)		<0.5	0.7	<0.5	<2.5	0.9	0.6	<0.5	1	<0.5	<0.5
pH		7.75	7.82	7.84	7.94	7.83	7.95	7.8	7.75		
Selenium (total)	ID	<2	<2	<2	<1.0	<2	<2	<2	<2	<2	<2
Selenium (soluble)		<2	<2	<2	<1.0	<2	<2	<2	<2	<2	<2
Silver (total)	1.4 µg/L	<0.1	<0.1	<0.1	<0.5	<0.1	<0.1	<0.1	<0.1	<0.1	0.4
Silver (soluble)		<0.1	<0.1	<0.1	<0.5	<0.1	<0.1	<0.1	<0.1	<0.1	0.1
Sus.Solids		6	<5	<5	12	<5	20	12	10		
Total Phosphorus	30 µg/L	0.02	<0.01	<0.01	<0.01	0.02	0.26	<0.01	<0.01	40	80
Vanadium (total)	100 µg/L	<0.5	<0.5	<0.5	1.6	<0.5	<0.5	<0.5	<0.5	<0.5	1.6
Vanadium (soluble)		<0.5	<0.5	<0.5	<1.0	<0.5	<0.5	<0.5	<0.5	<0.5	1.6
Zinc (total)	15 µg/L	18	22	14	22	27	74	36	22	15	19
Zinc (soluble)		18	20	12	<5	28	65	19	30	8	18
Anionic Surfactants as MBAS		0.4		<0.1	<0.1	0.1	0.1	<0.1	0.2		
Faecal Coliforms		~12		~2	~3	26	~2	20	~6		

Review Date	Next Review Date	Revision No	Document Owner	Page
25/07/2012	25/07/2013	1	Environment and Community Coordinator	Page 83 of 93
<b>DOCUMENT UNCONTROLLED WHEN PRINTED</b>				

Table 25 – Baseline Site Water Quality Downstream Sept 11 – March 12

Tested Pollutant	ANZECC (2000) Values (95%) Marine Environment	Water Quality Sample results from Sampling Point Downstream							Receiving Water Quality Results - Sept 2010	
		Sep-11	Oct-11	Nov-11	Dec-11	Jan-12	Feb-12	Mar-12	RW1 Chain Valley Bay	RW2 Marks Point
Aluminium (total)	ID	160	280	144	100	560	74	322	40	120
Aluminium (soluble)		<10	<10	<25	30	<10	12	96	<10	40
Ammonia as N	910 µg/L	<0.1	<0.1	<0.10	<0.10	0.03	<0.10	<0.10		
Arsenic (total)		1.4	1	1.3	0.8	2.1	<0.5	0.7	<0.5	1.9
Arsenic (soluble)	ID	1.3	0.9	<1.0	0.6	1.6	<0.5	<0.5	<0.5	2
Beryllium (total)	ID	<0.1	0.2	<0.5	<0.1	<0.1	<0.1	<0.1	<0.1	<0.1
Beryllium (soluble)	ID	<0.1	<0.1	<0.5	<0.1	<0.1	<0.1	<0.1	<0.1	<0.1
Cadmium (total)		0.3	<0.2	<0.26	<0.2	0.3	<0.2	<0.2	<0.2	0.4
Cadmium (soluble)	0.7 µg/L	0.3	<0.2	<0.25	<0.2	<0.2	<0.2	<0.2	<0.2	0.4
Chromium (total)		<0.5	0.6	<1.0	<0.5	0.8	<0.5	<0.5	<0.5	<0.5
Chromium (soluble)	4.4 µg/L	<0.5	<0.5	<1.0	<0.5	<0.5	<0.5	<0.5	<0.5	<0.5
Cobalt (total)		<0.2	<0.2	<0.5	<0.2	0.3	<0.2	0.2	<0.2	<0.2
Cobalt (soluble)	1 µg/L	<0.2	<0.2	<0.5	<0.2	<0.2	<0.2	0.3	<0.2	<0.2
Conductivity		50500	39200	39500	32200	38000	27800	29600		
Copper (total)		1	2	<2.6	<1	3	<1	<1	<1	4
Copper (soluble)	1.3 µg/L	1	<1	<2.5	2	2	<1	1	<1	2
Lead (total)		0.6	1	<0.5	<0.2	0.7	<0.2	<0.2	<0.2	1.2
Lead (soluble)	4.4 µg/L	0.4	<0.2	<0.5	0.2	<0.2	<0.2	0.3	<0.2	0.4
Mercury (total)		<0.0001	<0.0001	<0.0001	<0.0001	<0.0001	<0.0001	<0.0001	<0.1	<0.1
Mercury (soluble)	0.1 µg/L	<0.0001	<0.0001	<0.0001	<0.0001	<0.0001	<0.0001	<0.0001	<0.1	<0.1
Molybdenum (total)	ID	10.1	5.2	7.5	3.7	6.5	1.2	3.2	2.4	12

Review Date	Next Review Date	Revision No	Document Owner	Page
25/07/2012	25/07/2013	1	Environment and Community Coordinator	Page 84 of 93
<b>DOCUMENT UNCONTROLLED WHEN PRINTED</b>				

Tested Pollutant	ANZECC (2000) Values (95%) Marine Environment	Water Quality Sample results from Sampling Point Downstream							Receiving Water Quality Results - Sept 2010	
		Sep-11	Oct-11	Nov-11	Dec-11	Jan-12	Feb-12	Mar-12	RW1 Chain Valley Bay	RW2 Marks Point
Molybdenum (soluble)	ID	11.1	6	6.9	3.4	6.4	<0.1	3	2.5	11.6
Nickel (total)		<0.5	2.1	<2.6	0.7	1	0.7	1.1	0.8	0.7
Nickel (soluble)	7 µg/L	<0.5	<0.5	<2.5	1	<0.5	<0.5	1.4	<0.5	<0.5
pH		7.86	7.98	7.99	7.85	8.12	7.78	7.76		
Selenium (total)		<2	<2	1.2	<2	<2	<2	<2	<2	<2
Selenium (soluble)	ID	<2	<2	<1.0	<2	<2	<2	<2	<2	<2
Silver (total)		<0.1	<0.1	<0.5	<0.1	<0.1	0.1	<0.1	<0.1	0.4
Silver (soluble)	1.4 µg/L	<0.1	<0.1	<0.5	<0.1	<0.1	<0.1	<0.1	<0.1	0.1
Sus.Solids		38	16	18	<5	64	8	18		
Total Phosphorus	30 µg/L	<0.01	<0.01	<0.01	0.01	0.09	<0.01	<0.01	40	80
Vanadium (total)		1.7	1	2.2	<0.5	4.7	<0.5	0.9	<0.5	1.6
Vanadium (soluble)	100 µg/L	1.5	1	1	0.5	3	<0.5	<0.5	<0.5	1.6
Zinc (total)		6	16	6	9	10	11	14	15	19
Zinc (soluble)	15 µg/L	<5	<5	<5	19	<5	<5	18	8	18
Anionic Surfactants as MBAS			<0.1	0.1	0.1	0.1	<0.1	0.2		
Faecal Coliforms			110	~14	180	~2	570	250		

Review Date	Next Review Date	Revision No	Document Owner	Page
25/07/2012	25/07/2013	1	Environment and Community Coordinator	Page 85 of 93
<b>DOCUMENT UNCONTROLLED WHEN PRINTED</b>				

Table 26 – Baseline Site Water Quality Upstream Sept 11 – March 12

Tested Pollutant	ANZECC (2000) Values (95%) Marine Environment	Water Quality Sample results from Sampling Point Upstream							Receiving Water Quality Results - Sept 2010	
		Sep-11	Oct-11	Nov-11	Dec-11	Jan-12	Feb-12	Mar-12	RW1 Chain Valley Bay	RW2 Marks Point
Aluminium (total)	ID	280	180	282	160	160	414	222	40	120
Aluminium (soluble)		140	100	73	100	60	56	96	<10	40
Ammonia as N	910 µg/L	<0.1	<0.1	<0.10	<0.10	0.02	<0.10	<0.10		
Arsenic (total)		<0.5	<0.5	<1.0	0.6	0.8	0.6	<0.5	<0.5	1.9
Arsenic (soluble)	ID	<0.5	<0.5	<1.0	<0.5	0.6	<0.5	<0.5	<0.5	2
Beryllium (total)	ID	<0.1	<0.1	<0.5	<0.1	<0.1	<0.1	<0.1	<0.1	<0.1
Beryllium (soluble)	ID	<0.1	<0.1	<0.5	<0.1	<0.1	<0.1	0.2	<0.1	<0.1
Cadmium (total)		<0.2	<0.2	<0.26	<0.2	<0.2	<0.2	<0.2	<0.2	0.4
Cadmium (soluble)	0.7 µg/L	<0.2	<0.2	<0.25	<0.2	<0.2	<0.2	<0.2	<0.2	0.4
Chromium (total)		<0.5	<0.5	<1.0	<0.5	<0.5	<0.5	<0.5	<0.5	<0.5
Chromium (soluble)	4.4 µg/L	<0.5	<0.5	<1.0	<0.5	<0.5	<0.5	<0.5	<0.5	<0.5
Cobalt (total)		0.5	0.6	0.8	0.6	0.6	0.8	0.9	<0.2	<0.2
Cobalt (soluble)	1 µg/L	0.4	0.6	0.7	0.5	0.6	0.2	0.9	<0.2	<0.2
Conductivity		20400	17000	19700	13300	20700	11900	11900		
Copper (total)		<1	<1	3	<1	<1	<1	<1	<1	4
Copper (soluble)	1.3 µg/L	<1	<1	<2.5	<1	<1	<1	1	<1	2
Lead (total)		<0.2	<0.2	<0.5	0.3	0.5	0.3	<0.2	<0.2	1.2
Lead (soluble)	4.4 µg/L	<0.2	<0.2	<0.5	<0.2	<0.2	<0.2	0.4	<0.2	0.4
Mercury (total)		<0.0001	<0.0001	<0.0001	<0.0001	<0.0001	<0.0001	<0.0001	<0.1	<0.1
Mercury (soluble)	0.1 µg/L	<0.0001	<0.0001	<0.0001	<0.0001	<0.0001	<0.0001	<0.0001	<0.1	<0.1
Molybdenum (total)	ID	15.6	12	14.1	5.7	12.4	5.4	5.7	2.4	12
Molybdenum (soluble)	ID	16.8	13.2	13.5	5.1	11.4	2.7	5	2.5	11.6

Review Date	Next Review Date	Revision No	Document Owner	Page
25/07/2012	25/07/2013	1	Environment and Community Coordinator	Page 86 of 93
<b>DOCUMENT UNCONTROLLED WHEN PRINTED</b>				

Tested Pollutant	ANZECC (2000) Values (95%) Marine Environment	Water Quality Sample results from Sampling Point Upstream							Receiving Water Quality Results - Sept 2010	
		Sep-11	Oct-11	Nov-11	Dec-11	Jan-12	Feb-12	Mar-12	RW1 Chain Valley Bay	RW2 Marks Point
Nickel (total)		5.1	5.5	6.2	4.8	6.4	4.1	4.2	0.8	0.7
Nickel (soluble)	7 µg/L	5.3	5.7	5.8	4.6	5.8	<0.5	4.8	<0.5	<0.5
pH		7.86	7.65	7.87	7.86	7.87	7.74	7.54		
Selenium (total)		<2	<2	<1.0	<2	<2	<2	<2	<2	<2
Selenium (soluble)	ID	<2	<2	<1.0	<2	<2	<2	<2	<2	<2
Silver (total)		<0.1	<0.1	<0.5	<0.1	<0.1	<0.1	<0.1	<0.1	0.4
Silver (soluble)	1.4 µg/L	<0.1	<0.1	<0.5	<0.1	<0.1	<0.1	<0.1	<0.1	0.1
Sus.Solids		8	5	7	<5	8	12	<5		
Total Phosphorus	30 µg/L	<0.01	<0.01	<0.01	0.02	0.02	<0.01	<0.01	40	80
Vanadium (total)		<0.5	<0.5	<1.0	<0.5	<0.5	<0.5	<0.5	<0.5	1.6
Vanadium (soluble)	100 µg/L	<0.5	<0.5	<1.0	<0.5	<0.5	<0.5	<0.5	<0.5	1.6
Zinc (total)		9	7	11	14	6	11	9	15	19
Zinc (soluble)	15 µg/L	6	6	6	8	<5	<5	15	8	18
Anionic Surfactants as MBAS			<0.1	<0.1	0.1	0.1	<0.1	0.1		
Faecal Coliforms			570	460	1300	5200	430	570		

Review Date	Next Review Date	Revision No	Document Owner	Page
25/07/2012	25/07/2013	1	Environment and Community Coordinator	Page 87 of 93
<b>DOCUMENT UNCONTROLLED WHEN PRINTED</b>				

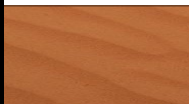

# APPENDIX C



## LakeCoal Pty Ltd

### Chain Valley Mining Extension 1 Project

### Environmental Impact Assessment:-

#### *Water Balance*

March 2013

---

EMG00-008



**GSS ENVIRONMENTAL**  
Environmental, Land and Project  
Management Consultants

## EXECUTIVE SUMMARY

LakeCoal is seeking an approval under Part 4, Division 4.1 of the Environmental Planning and Assessment Act 1979 to extend the currently approved extraction area at Chain Valley Colliery to allow underground mining of the Fassifern Seam, with all secondary extraction to occur beneath Lake Macquarie. This extension would allow continuation of mining operations at the Colliery (by a further 14 years) and would increase the maximum approved rate of production from 1.2 million tonnes per annum (Mtpa) to 1.5 Mtpa ROM coal. The additional 300,000 tonnes per annum would continue to be transported back to the existing pit top facilities by conveyor where it would be processed and then transported via private roads to Vales Point Power Station.

GSS Environmental (GSSE) was commissioned by EMGA Mitchell McLennan (EMM), on behalf of LakeCoal Pty Ltd, to prepare a Surface Water Assessment (SWA) to fulfil the requirements detailed in the Director-General's Requirements relating to the preparation of an Environmental Impact Statement (EIS) to accompany the Part 4 application. As part of the SWA a detailed daily time step water balance was undertaken in GoldSim in order to understand water demands and flows around the pit top area. It was developed to demonstrate that future water management at the mine is sustainable during the Mine Extension 1 Project.

A water balance was previously undertaken for Chain Valley Colliery by AECOM in July 2011. The water balance investigation for the SWA was undertaken independently from this previous water balance with only some model inputs compared for verification. This new water balance also investigated the pit top water use in more detail to aid the future decision making process in regards to water management at the site.

Key findings from this site water balance investigation include the following:

- Potable water used in the pit top area may be reduced by 32.3 kL/day (11.8 ML/year) as a result of proposed water saving measures at the Colliery, including the use of rainwater tanks and the reuse of water within the sedimentation ponds for dust suppression purposes;
- An investigation into the actual available underground storage capacity should be undertaken due to the importance of this storage in regards to the management of water during the life of the Proposal;
- LakeCoal should seek an amendment to EPL 1770 to include a condition that allows exceedances of the daily discharge volume limit when 10mm of rainfall has fallen on the premises within the preceding 24 hours; and
- LakeCoal should commit to limiting the maximum pump out rate from underground to 10.5 ML/day, within 12 months of the Proposal being approved, in order to adhere to aforementioned proposed EPL amendment. The timing of this commitment is due to the substantial upgrades involved with fully automating the pumps and having them controlled by a SCADA system.

# TABLE OF CONTENTS

<b>EXECUTIVE SUMMARY .....</b>	<b>1</b>
<b>1.0 INTRODUCTION.....</b>	<b>1</b>
1.1 Background.....	1
1.2 Scope of Work .....	1
<b>2.0 SITE CHARACTERISTICS .....</b>	<b>2</b>
2.1 Location and Site Operations .....	2
2.2 Climate / Rainfall.....	2
2.3 Topography.....	2
2.4 Surrounding Land Uses.....	2
2.5 Soils/Geology.....	3
2.6 Pit Top Catchment Areas .....	3
2.7 Water Management .....	4
2.7.1 Potable Water Supply.....	4
2.7.2 Water Storage and Treatment.....	5
2.7.3 Licensed Discharge Points.....	5
2.7.4 Site Water Management Overview.....	6
<b>3.0 METHODOLOGY .....</b>	<b>7</b>
3.1 Goldsim.....	7
3.2 Previous Water Balance Investigations .....	7
3.3 Model Representation and Accuracy.....	7
3.4 Data (Node Inputs and Outputs).....	8
3.4.1 Rainfall.....	8
3.4.2 Surface Runoff Calculations.....	10
3.4.3 Evaporation .....	11
3.4.4 Underground Water Extraction.....	12
3.4.5 Sedimentation Pond Characteristics .....	12
3.4.6 Loss of Water through Coal Export.....	13
3.4.7 Additional Data Supplied by LakeCoal.....	13
<b>4.0 MODELLING RESULTS .....</b>	<b>15</b>
4.1 Expected Discharge from Chain Valley Colliery.....	15
4.2 Potable Water Use.....	16
4.2.1 Potable Water Verification.....	16
4.2.2 Potable Water Savings.....	17
4.3 Sensitivity Analysis .....	17
<b>5.0 CONCLUSION .....</b>	<b>19</b>

**6.0 REFERENCES..... 20**

## **TABLES**

---

Table 1: Concentration Limits for LDP 1 (EPL 1770)..... 6

Table 2: Average Annual Rainfall Comparison of Nearby Weather Stations ..... 9

Table 3: Pit Top Catchment Areas, Soil Loss Parameters and Estimated Average Annual Runoff Volumes ..... 11

Table 4: Sedimentation Pond Parameters ..... 13

Table 5 – Supplied and Derived Data ..... 14

Table 6: Comparison of Calculated Total Pit Top Potable Water Usage..... 16

Table 7: Sensitivity Analysis Results ..... 17

## **FIGURES**

---

Figure 1 – Regional Context

Figure 2 – Water Management System (Including Proposed Structures)

Figure 3 – Existing Water Management System Schematic

Figure 4 – Proposed Water Management Schematic

Figure 5 – Water Balance Schematic as Modelled in GoldSim

Figure 6 – Annual Rainfalls in Chain Valley Region

Figure 7 – Average Adjusted Monthly Evaporation Rates

Figure 8 – LDP1 Discharge Results Assuming Constant Maximum Pumping Rate from Underground

## 1.0 INTRODUCTION

### 1.1 Background

Chain Valley Mine is located in the Newcastle coalfields, at the southern end of Lake Macquarie. The mine was established in 1960 to extract coal from the Wallarah, Fassifern and Great Northern coal seams. Extraction of the Wallarah seam has been completed, with extraction currently underway in the Fassifern Seam.

Mining of the existing coal resources already approved under MP 10\_0161 are expected to be completed around October 2013 or shortly thereafter. LakeCoal Pty Ltd is therefore seeking to obtain approval under the Environmental Planning and Assessment Act 1979 (EPA Act), to permit mining of additional coal resources within the Fassifern seam with all secondary extraction to be undertaken beneath Lake Macquarie. Secondary extraction within the Project Area will be undertaken using the miniwall method of mining and would provide resources to facilitate mining for approximately 14 years at a rate of 1.2 million tonnes per year (ROM).

LakeCoal have engaged EMGA Mitchell McLennan (EMM) to prepare the Environmental Impact Statement (EIS) for this proposed mining and GSS Environmental (GSSE) was subsequently engaged by EMM as a sub-consultant to undertake the Surface Water Assessment (SWA) component of this EIS.

As part of this SWA it is necessary to demonstrate that the current water management practices should continue to comply with licence conditions with respect to discharge, or if this is determined to be unachievable, recommend mitigation and/or management measures for the mine. A site water balance has been developed to understand water demands and flows around the pit top area (surface component of the mine). This site water balance is used to demonstrate that future water management at the mine is sustainable.

A water balance was previously undertaken for the site by AECOM in July 2011. The water balance described in this report was undertaken independently from this previous water balance with only some model inputs compared for verification. This new water balance investigated the pit top water use in more detail to aid the future decision making process in regards to water management at the site.

### 1.2 Scope of Work

Developing the site water balance involved the following key tasks:

- Reviewing existing information including current flow records;
- Identifying inputs/outputs for the site water balance;
- Developing a water balance model in GoldSim to quantify the site water balance; and
- Recommending future water management practices.

This report summarises the key outcomes from the site water balance together with any major assumptions made in modelling undertaken.

## 2.0 SITE CHARACTERISTICS

### 2.1 Location and Site Operations

Chain Valley Mine is an underground coal mine located on the southern end of Lake Macquarie with the pit top (i.e. surface facilities) positioned adjacent to the Vales Point Power Station in Mannering Park. The site is approximately 60 km south of Newcastle and within the Swansea-North Entrance Mine Subsidence District. Chain Valley Mine was established in August 1960, with a licence to extract coal from the Wallarah, the Great Northern and the Fassifern Seams. Extraction is currently being undertaken from the Fassifern Seam. The proposed permit for mining additional reserves within the Fassifern seam is expected to facilitate mining for an additional 14 years at a rate of 1.2 million tonnes per year (ROM).

A plan showing the location of Chain Valley Colliery is shown in **Figure 1**.

### 2.2 Climate / Rainfall

The Lake Macquarie region has a borderline oceanic/humid subtropical climate like much of central and northern NSW. Summers tend to be warm and winters are generally mild. Precipitation is heaviest in late autumn and early winter.

A review of the Bureau of Meteorology (BOM) website indicated that there were no weather stations located in the immediate vicinity of the Site, however, numerous stations were identified in the general Lake Macquarie region. All of these weather stations contain similar average annual rainfall statistics. Together, these weather stations contain over 100 years of complete daily rainfall data which made it suitable for use in this water balance described in **Section 3.4.1**.

### 2.3 Topography

The Colliery's pit top area is relatively flat with the majority of the runoff flowing east into the sedimentation ponds, prior to discharge. Earthen diversion drains exist on the northern and eastern boundaries and help to convey this runoff into the ponds. Overflow from the sedimentation pond system discharges to a nearby creek which flows into Lake Macquarie.

The car park and the adjacent access road are the only areas where the runoff does not discharge into the sedimentation ponds and is conveyed directly off-site. Management of the carpark runoff has recently been reviewed at the Colliery with recommendations and commitments provided within the Colliery's Water Management Plan (WMP). No watercourses traverse through the pit top facilities.

### 2.4 Surrounding Land Uses

The Colliery's pit top area is located on the western side of Chain Valley Bay, on relatively flat land, largely devoid of vegetation. It is situated in an existing industrial area accessed from Ruttleys Road.

The existing ventilation shaft and fan are located on freehold land at Tiembula Road, Summerland Point, on the eastern side of Chain Valley Bay. Parts of the Lake Macquarie State Conservation Area are located on both the eastern and western sides of the lake, which provide bushland and open space along the foreshore.

Neighbouring industrial facilities comprise Mannering Colliery to the south and Vales Point Power Station to the west. The nearest residential areas are Kingfisher Shores and Chain Valley Bay to the south-east, Mannering Park to the north-west, and Summerland Point and Gwandalan to the north-east.

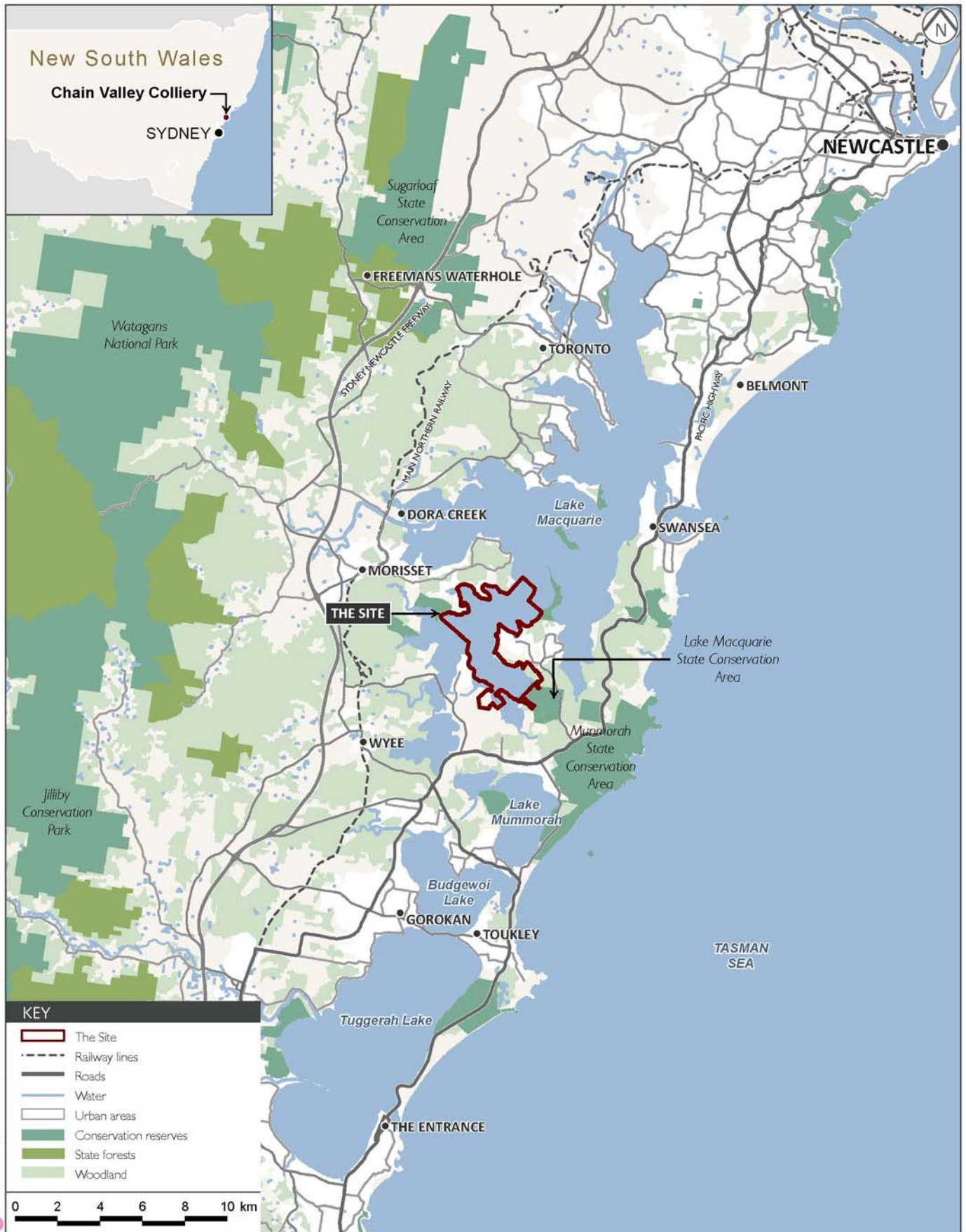

Integrated Design Solutions | 030634 Chain Valley Mine - ME1 F1.1 Rev A - 02 Aug 2012

Regional context

Chain Valley Colliery Mining Extension I - Environmental Impact Statement

Figure 1

The area surrounding the colliery is also used for a number of recreational purposes. Fishing and sailing are popular on Lake Macquarie, along with other water based recreational activities. Camping facilities, walking tracks and picnic areas are available within the Lake Macquarie State Conservation Areas.

## 2.5 Soils/Geology

The Colliery's surface facilities are situated on the shore of Lake Macquarie. This area principally comprises the Doyalson soil landscape with small parts on the Wyong soil landscape. The Doyalson soil landscape is characterised by gently undulating rises on Munmorah Conglomerate with broad crests, ridges and long gently inclined slopes. Local relief is up to 30 metres and slope gradient is less than 10%. Doyalson soils are strongly acidic, of low fertility and exhibit slight to high erodibility. The Wyong soil landscape is characterised by broad, poorly drained deltaic floodplains and alluvial flats of Quaternary sediments. Local relief is less than 10 metres and slope gradient is less than 3%. Wyong soils are strongly acidic, poorly drained impermeable, of very low fertility and contain saline subsoils.

## 2.6 Pit Top Catchment Areas

For the purpose of the water balance, runoff from the pit top area has been assessed in terms of four main catchment areas (shown in **Figure 2**) including:

- Catchment 1 – The carpark, office building and partial runoff from the workshop roof;
- Catchment 2 – The rear storage yard and oil water separator and the remaining workshop roofed area;
- Catchment 3 – The stockpile, entry road and bathhouse; and
- Catchment 4 – The sedimentation ponds.

Runoff from Catchment 1 has historically been considered clean catchment and is conveyed to the north of the pit top area with no runoff from this catchment reporting to the sedimentation ponds. As such, this catchment was not included in the water balance model.

The majority of runoff from Catchment 2 currently drains east into the sedimentation ponds via a pit and pipe network and earth bunding. The majority of the storage yard is gravelled hardstand, however, there are some exposed disturbed areas due to regular heavy vehicle movement resulting in runoff also containing sediment. This runoff is captured within the pollution control dams (dams D11, D12 and D13 shown in **Figure 2**) which function as primary settling ponds prior to discharge into the main sedimentation ponds D7 and D9.

Runoff from Catchment 3 is contained by two main drainage channels that surround the coal stockpile and report to the sedimentation ponds (Catchment 3). Runoff from this area contains a significant amount of coal fines. The runoff from the area adjacent to the weigh bridge currently collects and pools in an adjacent drainage channel. Runoff from the main entry/haul road contains coal fines and a small component of this catchment has been reporting to the clean water carpark catchment (Catchment 1). The majority of the runoff from Catchment 3 reports to sedimentation dams D1 to D6. These dams also function as primary settling ponds before discharging into the main mine water sedimentation ponds. A small portion of the area surrounding the Run-of-Mine (ROM) bin and bathhouse, reports to the storage yard area (Catchment 2).

The WMP includes measures to improve water management on site and ensure water management structures comply with industry best practice. The minor upgrades and modifications to infrastructure proposed at the pit top area will not increase volumes of stormwater runoff from the Site.

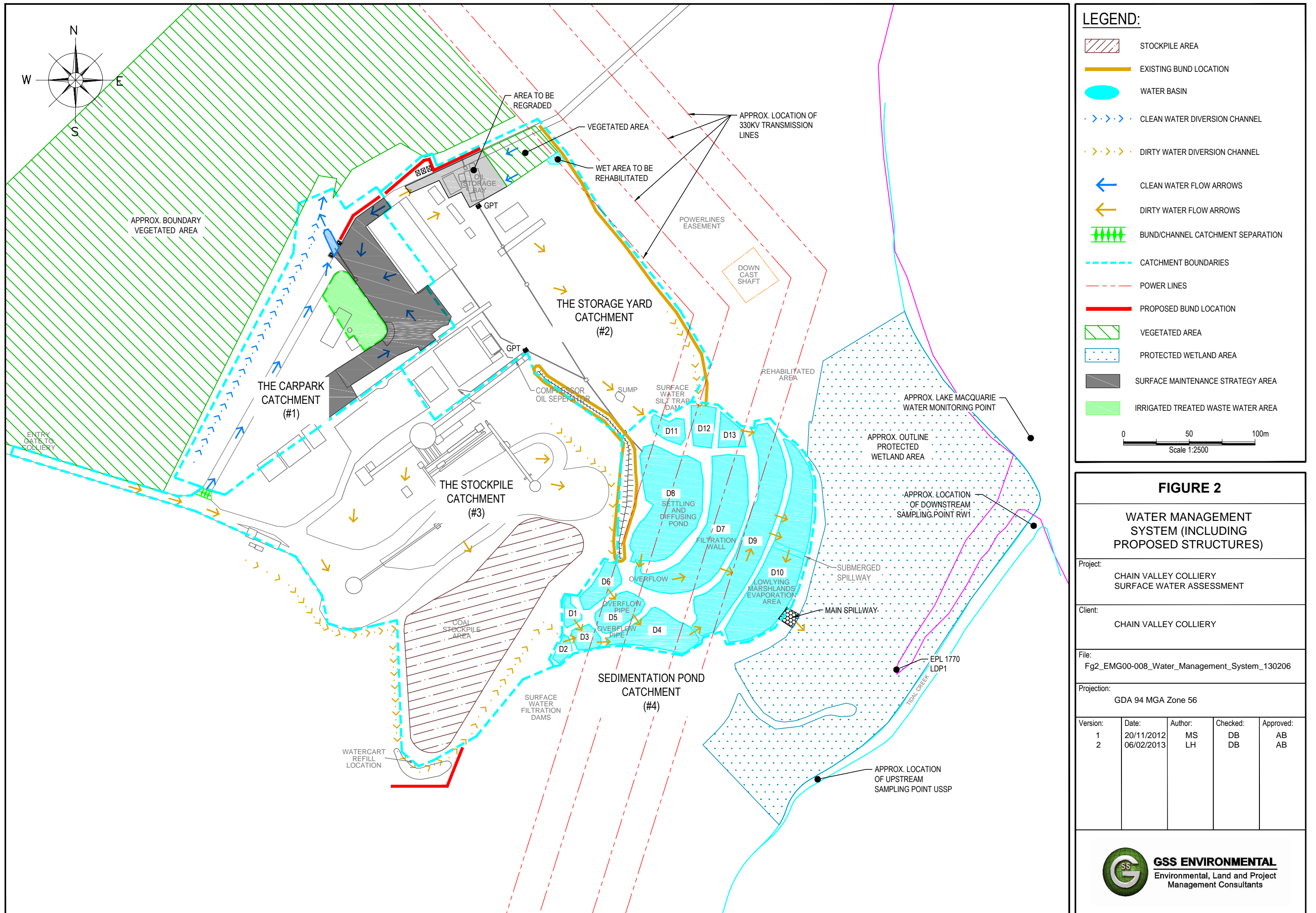

## **2.7 Water Management**

### **2.7.1 Potable Water Supply**

#### **2.7.1.1 Existing Potable Water Use**

Potable water, obtained from the Wyong Shire Council, provides the water required to support the Colliery's operation. Information supplied by LakeCoal indicates that approximately 132 ML/year of potable water is used by the Colliery. Potable water is consumed in the following processes:

- When cutting coal at the coal face - to reduce respirable dust and propensity for frictional ignition of coal dust and methane gas;
- When transferring coal along the underground conveyor system and at transfer points - to reduce dust make;
- In cleaning;
- In equipment;
- For drinking water supply
- For emergency fire fighting purposes; and
- Pit top amenities, wash down and dust suppression activities.

It is estimated that approximately 20 ML/year (15%) is used for pit top operations and 112 ML/year (85%) is used in the underground operations. As required by Schedule 3, Condition 31(d) of MP10\_0161, practical measures to minimise potable water consumption and maximise recycled water use have been and continue to be investigated by LakeCoal, as discussed in the WMP. Potential initiatives currently being investigated include;

- Reuse of dirty water contained within the sedimentation ponds for dust suppression purposes;
- Using the water cart for dust suppression of the ROM stockpile instead of the existing sprinkler system which is less efficient with water and is currently not operational; and
- Installing rainwater tanks on the operations block and workshop area including plumbing to the bathhouse.

However the use of non-potable water in all operational activities is not possible due to its quality, work health and safety and equipment requirements.

#### **2.7.1.2 Future Changes to Potable Water Use**

Since the introduction of the miniwall mining method, the demand for potable water in underground operations has increased. An additional amount of potable water used in the underground operations is therefore likely due to the Proposal. From discussions with LakeCoal, it was estimated that this increase could be as high as 25%. Although this increase was incorporated into the site water balance, it should be noted that this increase is very much an upper limit estimate and is considered conservative for the proposed works at the Colliery.

Potable water is an increasingly valuable and scarce resource and stakeholder concerns have been raised regarding the volume of potable water being consumed on-site. Therefore, LakeCoal is committed to trying to minimise their potable water use at the site. As part of the EA (AECOM, 2011), LakeCoal made a number of commitments including the installation of rainwater tanks on two

buildings at the pit top area. These rainwater tanks, which would collect runoff from the workshop and old bath house roof areas, were included in the water balance investigation.

LakeCoal also intend on reducing the potable water consumption at the site by drawing water from the sedimentation ponds to use on-site for dust suppression purposes. LakeCoal has indicated that Pond D6 is practically the most appropriate pond to draw the water from, although the surrounding ponds D1-D5 could also be used if required. This water use for dust suppression purposes was also included in the water balance modelling of the site.

### 2.7.2 Water Storage and Treatment

With the exception of the carpark stormwater runoff, all of the Colliery's 'dirty' water including surface water runoff, septic treated bathhouse wastewater, treated water from the oil water separator and underground mine water is conveyed into the sedimentation ponds (shown in **Figure 2**) prior to discharge under Environment Protection Licence (EPL) 1770. These ponds treat the collieries wastewater and runoff quality through the settlement of fines and suspended solids. In addition, they also prevent hydrocarbon spills from discharging off-site and into Lake Macquarie. They have been constructed with a mixture of earth, crushed rock, crushed recycled brick and stone and are interconnected through a series of overflow pipes and spillways.

Water is directed through the ponds from a number of inlet locations. A detailed survey of the ponds was undertaken by Pearson and Associates in 2009 with the relative storage capacities provided in **Table 4**. Runoff from the stockpile area is collected primarily by ponds D1, D2 and D6 and is combined into D4 and D5 before flowing into D9. Runoff from the storage yard is directed to D11, D12 and D13 before also overflowing into D9.

The underground mine water is pumped to a pit adjacent to the compressor house and is combined with the septic treated wastewater from the bathhouse, the treated compressor condensate water and runoff from the ROM bin area. From this pit the water is piped to D8 for settling and diffusion. Water within D8 spills into D7 via a spillway at the southern end of the pond however due to the leaky nature of the ponds an unknown amount of water diffuses through the pond wall. The water in D7 flows into D9 in a similar manor. In D9 the underground water is combined with the pit top runoff.

The primary spill from D9 to D10 is at the northern end of D9. Once in D10, the water travels over a shallow buffer spillway to the main discharge spillway and offsite at LDP 1. Currently the main discharge from the LDP is un-metred and the quantity of water discharged from site is calculated from continuous monitoring of the underground pumping rates and surface flow meters. As noted in the SWA report LakeCoal are committed to upgrading Sedimentation Pond D10 including upgrades to the spillway, metering and embankments.

### 2.7.3 Licensed Discharge Points

The discharge of excess mine water from the sedimentation and pollution control ponds is licensed under the *POEO Act* by the Environment Protection Authority (EPA) through the Chain Valley Colliery EPL 1770. Under EPL 1770 there is a single licensed discharge point for the Colliery (LDP 1) shown in **Figure 2**. The EPL has been modified a number of times, most recently in December 2011. A draft variation to EPL 1770 was also issued by LakeCoal to the EPA on 7<sup>th</sup> February 2012. The EPA subsequently issued a draft variation to LakeCoal on 14<sup>th</sup> November 2012 which LakeCoal responded to with comments on 3<sup>rd</sup> December 2012. At the time that this SWA was finalised (February 2013) LakeCoal had not received any further feedback from the EPA and had not been issued with the EPL variation.

LDP 1 has a daily discharge limit of **12,161 kL/day** and a limit for pH and TSS as shown in **Table 1**.

**Table 1: Concentration Limits for LDP 1 (EPL 1770)**

Pollutant	Unit of Measure	100 <sup>th</sup> percentile Concentration Limit
pH	pH	6.5-8.5
TSS	Milligrams per litre (mg/L)	25

Currently, discharge from Site is un-metred and is calculated from continuous monitoring of the underground pumping rates and surface flow meters. Water currently leaks from Pond D10 as per **Figure 2** and much of this water does not pass through LDP 1. LakeCoal is committed to rectifying LDP 1 and (as described in **Section 2.7.2**) has engaged a dam engineer to design a metred spillway to be able to obtain direct measurements of the daily discharge from Site. LakeCoal is committed to upgrading the main embankment and discharge monitoring point of the final sediment dam as part of the Proposal.

EPL 1770 initially contained two discharge points, one at the pit top area (current) and a second at the Ventilation Shaft Site. These two points had individual discharge limits of 8161 kL/day and 4000 kL/day respectively. The separate discharge points related to the workings in both the Wallarah and Great Northern Seams, which had different pumps and pump out lines. With the cessation of mining in the Wallarah Seam (1997), the subsequent construction of a dewatering borehole from the Wallarah to the Great Northern Seam, and decommissioning of the pump out line leading to the Ventilation Shaft Site in 2003, the EPL was amended to combine the discharge volume limit (12,161 kL/day) to the single point at the pit top area as is currently contained in EPL 1770. It is expected that these volumes were originally based on mine dewatering data, with no consideration given to surface water runoff volumes.

#### 2.7.4 Site Water Management Overview

A schematic representation of both the existing and proposed water management system at the Colliery is shown in **Figures 3** and **4** respectively. **Figure 4** includes measures that LakeCoal have previously committed to (including rainwater tanks and dust suppression using water from the sedimentation ponds). The mine water balance has been developed by considering the major inputs and outputs in the mine water cycle. Major inputs include:

- Groundwater inflow into the underground mining areas;
- Potable Water; and
- Runoff from the catchments at the pit top area.

The major outputs and discharges from the Chain Valley water cycle include:

- Discharge from the sedimentation ponds via LDP 1;
- Evaporation, primarily from free water surfaces such as the sedimentation ponds;
- Runoff from the carpark and access road; and
- A relatively small amount of water contained in the export coal.

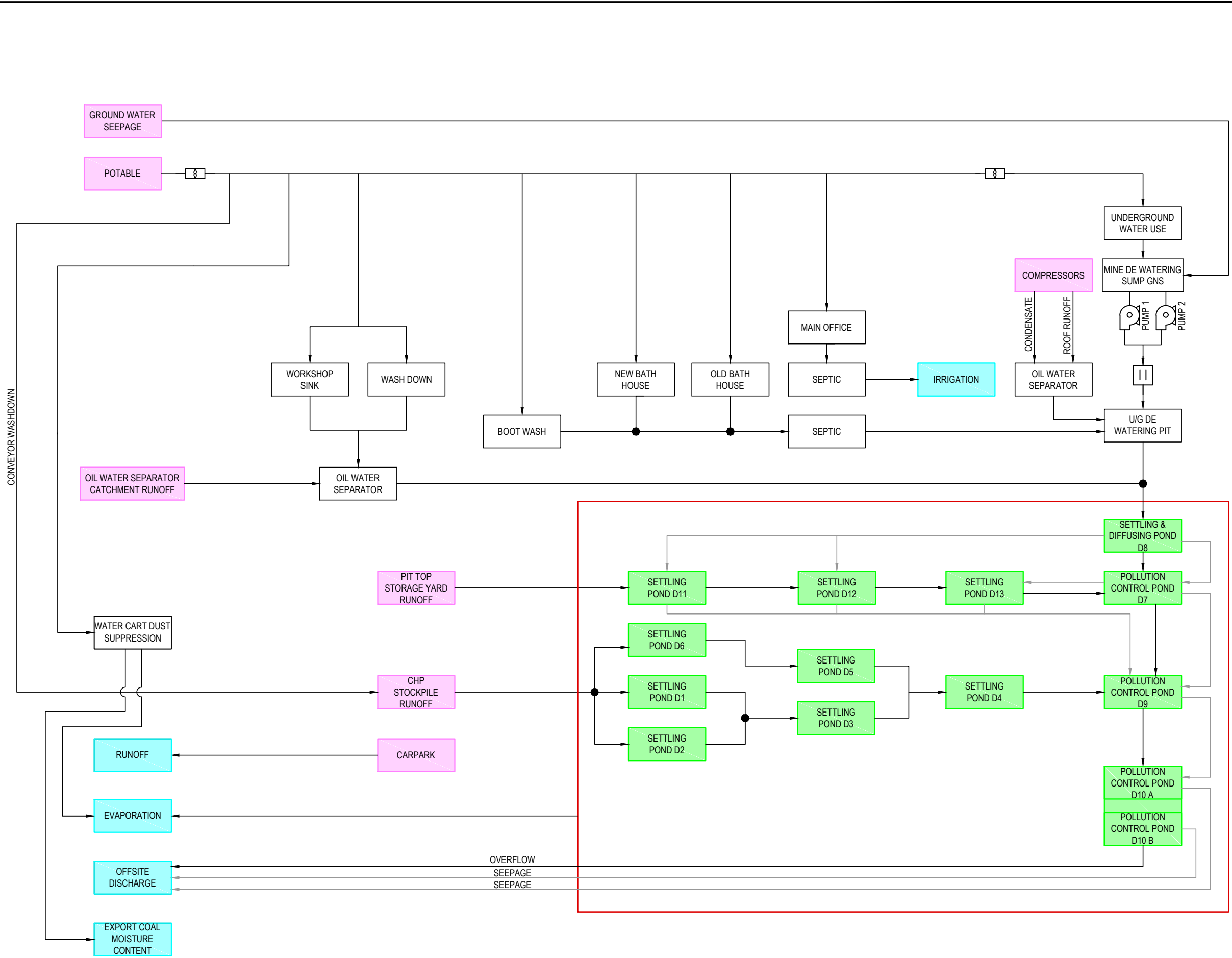

**LEGEND**

- WATER STORAGE
- WATER INPUTS
- WATER OUTPUTS
- PUMPS
- MECHANICAL FLOW METER
- MAGNETIC FLOW METER
- FLOW DIRECTION

**FIGURE 3**

**EXISTING WATER MANAGEMENT SYSTEM SCHEMATIC**

Project:  
CHAIN VALLEY COLLIERY  
SURFACE WATER ASSESSMENT

Client:  
CHAIN VALLEY COLLIERY

File:  
Fg3\_EMG00-008\_Water\_Management\_System\_121120

Projection:  
MGA\_94 - ZONE 56

Version:	Date:	Author:	Checked:	Approved:
A	28/08/2012	MS	DB	AB
B	20/11/2012	MS	DB	AB

**GSS ENVIRONMENTAL**  
Environmental, Land and Project  
Management Consultants

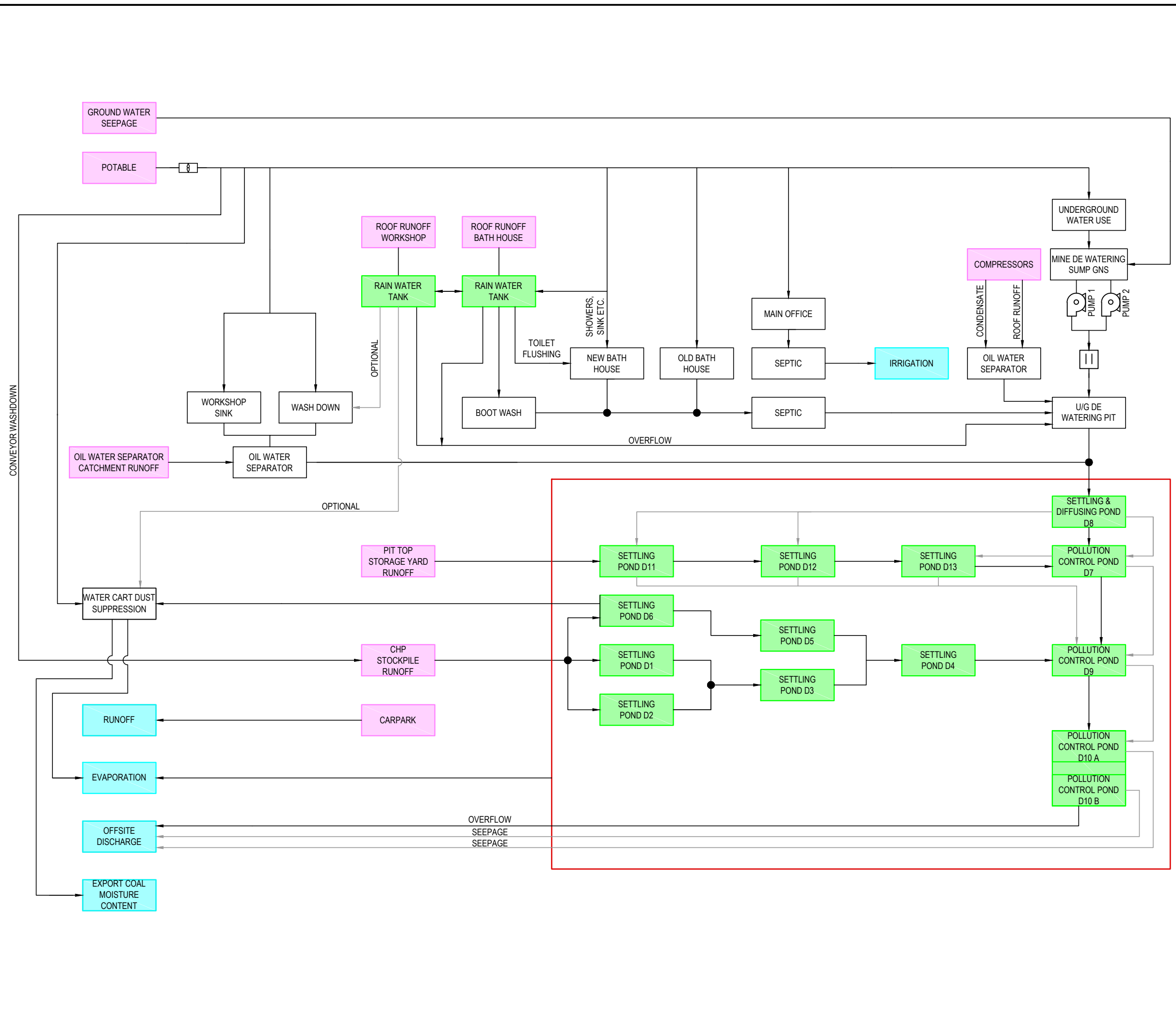

### LEGEND

- WATER STORAGE
- WATER INPUTS
- WATER OUTPUTS
- PUMPS
- MECHANICAL FLOW METER
- MAGNETIC FLOW METER
- FLOW DIRECTION

### FIGURE 4

#### PROPOSED WATER MANAGEMENT SYSTEM SCHEMATIC

Project: CHAIN VALLEY COLLIERY SURFACE WATER ASSESSMENT

Client: CHAIN VALLEY COLLIERY

File: Fg4\_EMG00-008\_Water\_Management\_System\_121120

Projection: MGA\_94 - ZONE 56

Version:	Date:	Author:	Checked:	Approved:
A	28/08/2012	MS	DB	AB
B	20/11/2012	MS	DB	AB

**GSS ENVIRONMENTAL**  
Environmental, Land and Project Management Consultants

## 3.0 METHODOLOGY

### 3.1 Goldsim

The model used to represent the Colliery water balance was GoldSim Version 10.50 (GoldSim Technology Group LLC). This software is a graphical, object oriented system simulation software for completing either static or dynamic systems. It is like a “visual spreadsheet” that allows one to visually create and manipulate data and equations.

Simulation, in this context, is defined as a process of creating a model of an existing or proposed system (such as a mine water management system) in order to identify and understand the factors that control the system performance or predict (forecast) the future behaviour of the system.

### 3.2 Previous Water Balance Investigations

A water balance was undertaken for the site by AECOM in July 2011. The water balance investigation documented in this report was undertaken independently from this previous water balance with only some model inputs compared for verification. This new water balance included a more detailed investigation of the pit top water use to aid the future decision making process in regards to water management at the colliery.

### 3.3 Model Representation and Accuracy

The Colliery water cycle, as proposed (including increased quantities of water make from underground, rainwater tanks, reuse dirty water from dams for dust suppression purposes etc.) is shown in **Figure 2**, with a schematic water flow diagram provided in **Figure 4**. This system was simplified and modelled in GoldSim as shown in **Figure 5**. The following simplifications were incorporated in the model:

- Daily time steps over a simulation length of over 100 years were used for the analysis – daily rainfall data was the shortest data period available;
- A monte carlo (probabilistic) simulation with 100 realisations to simulate the uncertainty in the model results brought about by the variation in pumped flows from underground and a deterministic simulation to model water processes at the site when pumping at the maximum pump rate from underground (worst case scenario);
- The underground storages within the Wallarah and Great Northern Seams were not modelled in the water balance due to operational uncertainties and uncertainties regarding the actual size of these storages. Based on information provided by LakeCoal these underground storages were assumed to be sufficient to store water during periods of wet weather;
- The carpark catchment runoff was not included in the water balance as it does not report to the sedimentation ponds;
- Runoff from catchments was represented by an initial loss/runoff factor, as described in **Section** Error! Reference source not found.;
- The compressors at the site were not included for simplicity as their contribution to the overall water cycle was considered to be negligible;
- Operating rules/precedents were established within the model in accordance with advice from LakeCoal. In reality the same decisions may not be made by staff due to influences outside the model;

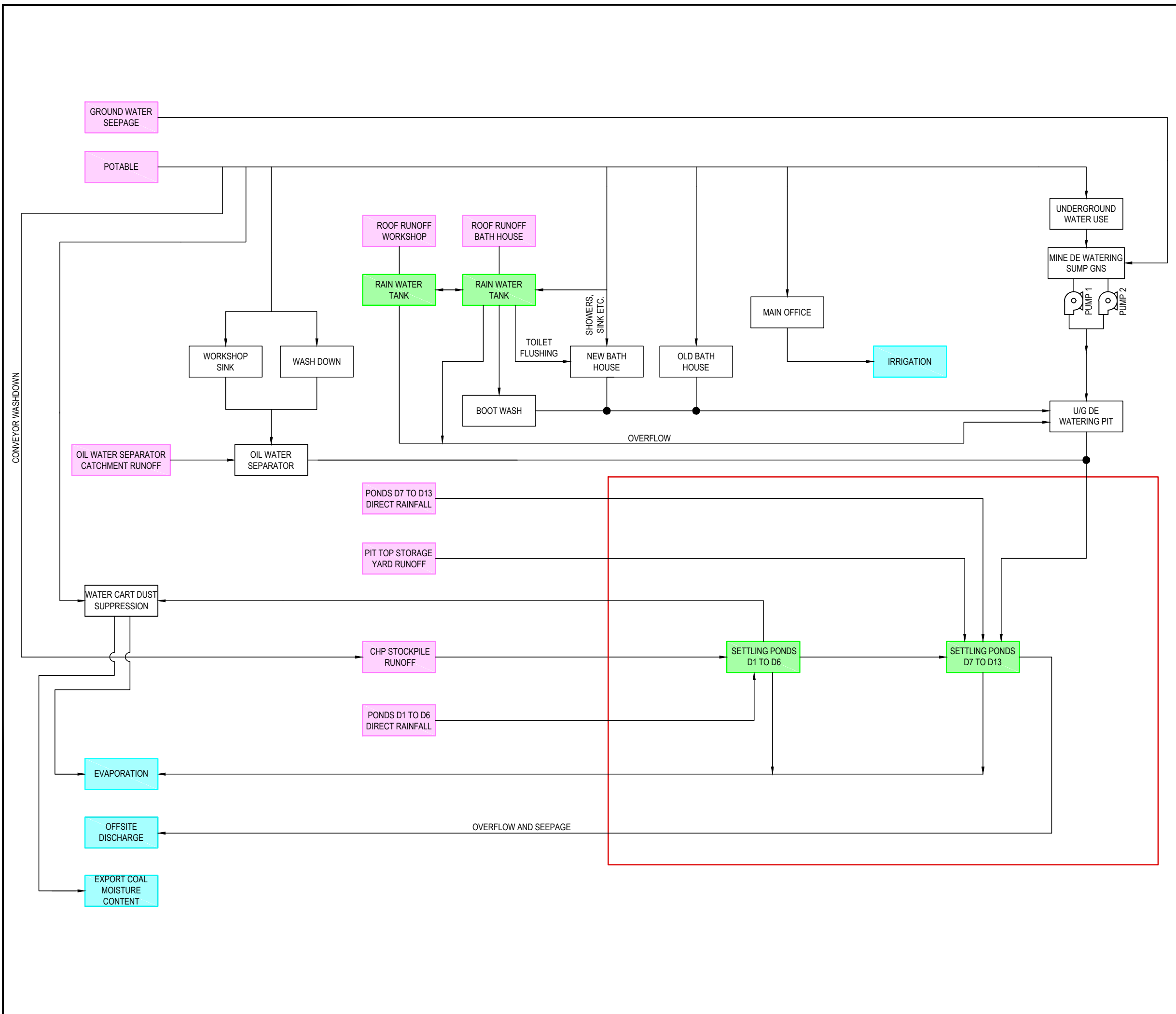

**LEGEND**

- WATER STORAGE
- WATER INPUTS
- WATER OUTPUTS
- PUMPS
- FLOW DIRECTION

**FIGURE 5**

**WATER BALANCE SCHEMATIC  
AS MODELLED IN GOLDSIM**

Project:  
CHAIN VALLEY COLLIERY  
SURFACE WATER ASSESSMENT

Client:  
CHAIN VALLEY COLLIERY

File:  
Fg5\_EMG00-008\_Water\_Management\_System\_121120

Projection:  
MGA\_94 - ZONE 56

Version:	Date:	Author:	Checked:	Approved:
A	28/08/2012	MS	DB	AB
B	20/11/2012	MS	DB	AB

**GSS ENVIRONMENTAL**  
Environmental, Land and Project  
Management Consultants

- Rainwater tanks collecting runoff from the workshop and old bath house roofed areas were modelled as an individual tank. Overflow from this combined tank was modelled as occurring when the capacity of the tank exceeded 80% of the overall capacity. Similarly, the tank was filled up with potable water when the capacity dropped below 20% of the overall capacity to ensure water was always available for proposed uses (toilet flushing and bootwash etc.);
- Ponds D1 to D6 and Ponds D7 to D13 were each modelled as single storages to simplify the water balance processes at the site;
- No amenity potable water used (sinks, showers, toilets, etc.) was assumed to be lost from the water balance system. In reality a small fraction of this water may be lost (e.g. through consumption, etc.) however this loss was considered to be negligible in regards to the overall site water balance; and
- Daily dust suppression was modelled to occur on days when less than 5mm of rain fell on the site. This dust suppression water was then modelled as leaving the site via either evaporation or within the exported coal.

The accuracy of the model and results are limited by the following factors:

- Lack of sub metering data regarding pit top and specific areas of underground usage of potable water;
- Lack of water cart usage records to calculate seasonal dust suppression rates. Records from Summer and Autumn were available and an average daily dust suppression rate from these records was calculated and used in the water balance; and
- Distance between Peats Ridge BOM weather station (used for pond evaporation rates) and the site of 33km.

The effect of these errors is considered to be negligible in comparison to the variation in the daily volumes of water being extracted from the underground workings. It is also important to note that the volumes of water discharged via LDP 1 are not currently metered and hence the extent of any errors cannot be verified. Reference should be made to the Groundwater Assessment Report (Geoterra, 2012) regarding the accuracy of the expected volumes of water make as a consequence of underground mining that must be pumped to the surface and, ultimately, to the LDP.

Calibration of the model parameters was not possible in this investigation due to the lack of downstream monitoring information at LDP 1. A broad brush validation of the model results was undertaken based on a range of Average Recurrence Interval (ARI) rainfall events, a generalised estimate of storage capacity available within the sedimentation ponds, pumping rates, catchment areas and runoff coefficients. This 'sanity check' of the results demonstrated a strong correlation between the site discharges calculated for certain rainfall events and within the GoldSim model.

Where assumptions have been made, they have generally been conservative. Therefore, results presented in this section are considered to represent potential worst case impacts.

### **3.4 Data (Node Inputs and Outputs)**

#### **3.4.1 Rainfall**

There are no long term weather stations located in the immediate vicinity of the Site, however numerous stations are located in the general Lake Macquarie region. Rainfall data was obtained from the BOM's website for these stations. A comparison of the average annual rainfalls at these stations is provided in **Table 2**. Rainfall information for a weather station at Mannering Colliery was also obtained. However, only 14 months of data was available. It was therefore excluded from the water balance model.

**Table 2: Average Annual Rainfall Comparison of Nearby Weather Stations**

Weather Station ID	Weather Station Number	Average Annual Rainfall (mm)
Norah Head AWS	61366	1212
Wye (Wye Farms Rd)	61082	1171
Swansea (Catherine St)	61377	1292
Gorokan (Goobarabah St)	61387	1175
Morisset (Balcolyn (Bay Street))	61041	1000
Bolton Point (The Ridge Way)	61133	1090
Williamtown RAAF	61078	1127

The dataset developed for the water balance used information from the Wye and Norah Head stations. There are other stations in the general vicinity however these stations (Wye and Norah Head) were selected due to their proximity to the Colliery and length and completeness of the data, which together, provide over 100 years of rainfall data. A summary of the annual rainfall data used in the water balance is provided in **Figure 6**.

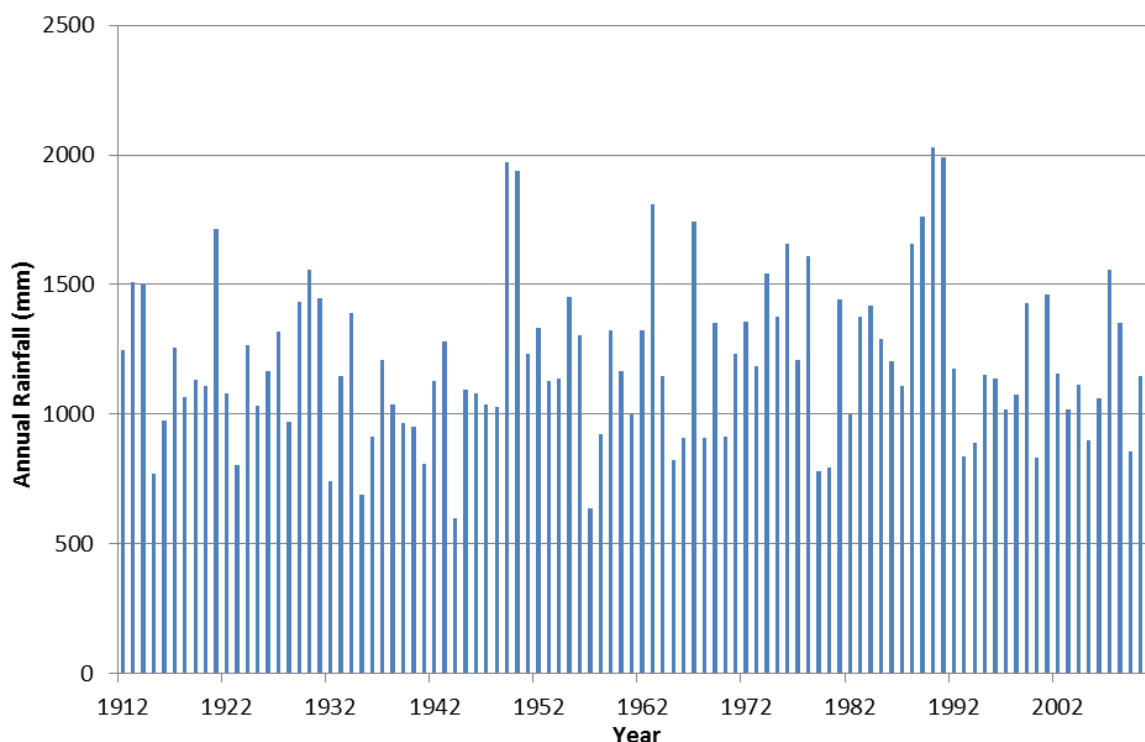

**Figure 6 – Annual Rainfalls in Chain Valley Region**

**Figure 6** demonstrates the variability in the annual rainfall at the site. Rainfall statistics for this data includes:

- Minimum annual rainfall – 600mm in 1944;
- Average annual rainfall – 1206mm;

- Median annual rainfall – 1155mm; and
- Maximum annual rainfall – 2031 in 1990.

### 3.4.2 Surface Runoff Calculations

Runoff volumes from the pit top areas were estimated using the rainfall data described above. The pit top area was segregated into four distinct catchments (as summarised in **Section 2.6**) using contour information provided by LakeCoal, information from the EA (AECOM 2011) and observations made by GSSE personnel during previous site inspections. These catchments were further broken up into eight sub-catchments for the purpose of the Colliery's water balance, as shown in **Table 3**.

With the exception of the carpark, runoff from each of these sub-catchments is directed to the sedimentation ponds. LakeCoal has committed to installing rainwater tanks connected to the workshop and old bath house roofs. As such, these were included in the GoldSim model. Runoff from the car park discharges directly off-site, hence it is not part of the mine water cycle. Management of this carpark runoff has recently been reviewed at the Colliery with proposed water quality control measures contained within the WMP.

The daily step GoldSim model was used to estimate the surface water runoff from different sub-catchments at the pit top area. An initial loss and runoff factor was assigned to each sub-catchment. This was used to convert daily rainfalls into surface runoff values when the daily rainfall exceeded the initial loss of rainfall.

All hardstand areas were assigned an initial loss value of 2mm and a runoff factor of 0.9 which equates to a high proportion of rainfall/runoff. These runoff coefficients are considered conservative but reflect the large impermeable area in the catchment which includes laydown areas, compacted roads and coal stockpile areas. The free water surfaces of the sedimentation ponds and the roofed areas were modelled as completely impervious areas, capturing all precipitation.

Catchment areas and the estimated average annual runoff volumes estimated from the GoldSim model are provided in **Table 3**. This table also indicates which of the four main catchments (as shown in **Figure 2**) that these more specific areas fall within.

**Table 3: Pit Top Catchment Areas, Soil Loss Parameters and Estimated Average Annual Runoff Volumes**

Major Catchment Name	Sub-Catchment Name	Catchment Area (ha)	Initial Soil Loss (mm)	Runoff Factor	Average Annual Runoff Volume (ML/year)
Carpark (Catchment 1)	Carpark (not modelled)	NA	NA	NA	NA
Storage Yard (Catchment 2)	Oil Water Separator	0.15	2	0.9	1.40
	Workshop (Roof)	0.24	2	0.9	2.82
	Old Bath House (Roof)	0.11	2	0.9	1.29
	Pit Top Storage Yard	3.03	2	0.9	27.63
Stockpile (Catchment 3)	CHP Stockpile	5.34	2	0.9	48.70
Sedimentation Ponds (Catchment 4)	Ponds D1 to D6	0.41	0	1.0	4.93
	Ponds D7 to D13	1.97	0	1.0	23.54
<b>Total Catchment reporting to Sedimentation Ponds (excluding carpark)</b>		<b>11.25</b>	<b>-</b>	<b>-</b>	<b>110.31</b>

### 3.4.3 Evaporation

Evaporation data was obtained from the BOM's station at Peats Ridge on Waratah Road (station number 61351), approximately 33km south-west of the mine. This was the closest meteorological weather station to the Colliery with over 25 years of evaporation information. Evaporation data from this weather station was adjusted for the change in site conditions from the measuring site to the sedimentation ponds by multiplying the average monthly rates by a pan coefficient of 0.7.

**Figure 7** provides a representation of the adjusted average monthly evaporation at this weather station.

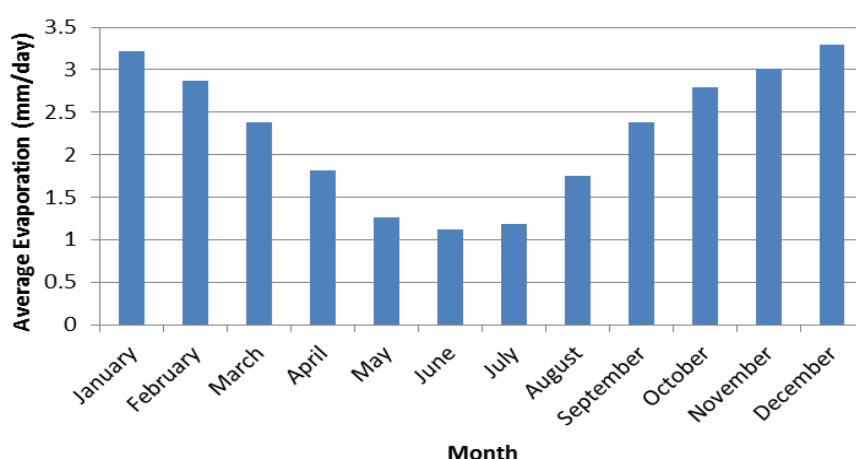

**Figure 7 – Average Adjusted Monthly Evaporation Rates**

The average annual evaporation rate was approximately 824mm as compared to the annual average rainfall of approximately 1206mm giving an annual surplus (difference between annual rainfall and annual evaporation) of approximately 382mm.

Evaporation from the sedimentation ponds was calculated using a daily step within the GoldSim model similar to the runoff model calculations. This model used the evaporation rate, modified by the pan coefficient, and the surface area of the ponds, which was calculated using survey data provided by LakeCoal. Modelling in GoldSim indicated that approximately 19.2 ML of water would evaporate out of the sedimentation ponds on average every year.

#### 3.4.4 Underground Water Extraction

The Groundwater Assessment (Geoterra, 2012) undertaken for this Proposal predicted that the average daily water volumes pumped from the coal face would increase from approximately 7.3 ML/day to 10.5 ML/day as a result of the Proposal. This estimated pumping rate is an average value and therefore pumped flow rates may exceed this value on occasions. It should be noted however, that this average daily volume was calculated as an 'end of mining' estimate and can be considered a 'worst case' prediction of groundwater inflow rates and is not expected to occur for the majority of the Proposal life.

Pump rate information provided by LakeCoal indicates that the two existing underground dewatering pumps from the Great Northern Seam sump have a maximum pumping rate of 72 L/sec and 64 L/sec respectively. This equates to a total maximum pumping rate from underground of approximately 11.75 ML/day. However, within 12 months of the Proposal being approved LakeCoal are committed to limiting the main underground pumps to a maximum pump out rate of 10.5 ML/day (equivalent to the predicted average daily volume that will need to be pumped from the coal face during the later stages of the Proposal). The timing of this commitment to limit the pumped volume from underground is due to the substantial upgrades required to fully automate the pumps and have them controlled by a SCADA system.

It is noted that a number of storages exist in both the Great Northern and Wallarah Seams. As such, it would be possible to turn these pumps off during periods of high rainfall in order to stay within the LDP discharge limit of 12.161 ML/day.

#### 3.4.5 Sedimentation Pond Characteristics

Information pertaining to the GoldSim modelling of the sedimentation ponds was obtained from survey data supplied by LakeCoal. This information is shown in **Table 4**. It should be noted that the volume of Pond D6 was not available and was estimated based on a 1m depth, the surface area and standard stage/storage relationships. Ponds D1 to D6 and D7 to D13 were each modelled as single storages to simplify the water balance processes at the Site.

**Table 4: Sedimentation Pond Parameters**

<b>Pond</b>	<b>Surface Area (m<sup>2</sup>)</b>	<b>Volume (m<sup>3</sup>)</b>
D1	201	80
D2	178	51
D3	317	284
D4	1153	547
D5	726	770
D6	568	568 <sup>1</sup>
<b>Total Ponds D1 to D6</b>	<b>3143</b>	<b>2300</b>
D7	3323	3856
D8	3423	2933
D9	3287	3796
D10	3707	4802
D11	391	297
D12	523	229
D13	370	168
<b>Total Ponds D7 to D13</b>	<b>15 024</b>	<b>16 081</b>

1. Calculated using surface area and assumptions from LakeCoal based on site observations.

### 3.4.6 Loss of Water through Coal Export

During mining and conveying, the moisture content in the coal increases due to the use of water sprays at the coal face and at transfer points along the conveyor system. A review of the Colliery's coal analysis data indicates that the inherent (air dried) moisture content of the coal from underground is approximately 2.7%. This same data indicates that the total moisture of the Colliery's coal that is exported from the Colliery is approximately 7.3% which means that around 4.6% of this total moisture content is added to the coal prior to export. This equates to 69,000 tonnes of additional water at the proposed maximum rate of production of 1.5 Mtpa. Therefore, approximately 69.0 ML of water is exported from the Colliery every year, or 188.9 kL/day.

### 3.4.7 Additional Data Supplied by LakeCoal

A limited amount of water usage and flow monitoring data at Colliery was available for this water balance investigation. However, where historic information was lacking, data and operational information was made available to best derive estimates of the respective water balance parameters (flow rates, water usage, etc.). Additional data supplied by LakeCoal, as used in the water balance model, is shown in **Table 5**, as well as comments/assumptions on how this data was derived.

Table 5 – Supplied and Derived Data

Parameter	Value	Comments/Assumptions
Potable Water: Underground (includes increase of 25% to account for any additional underground potable water demand)	139.583 ML/yr	Average of underground potable water from March and April 2012 (monitored water use) with an additional 25% to account for increased potable water used underground as a result of the Proposal.
Potable Water: Main Office	211 L/day	Includes shower, sink and toilet facilities. Shower (26 L/day): Assumes 9L/min, 10 min/person, 2 showers per week. Toilet (154 L/day): Assumes 12 employees, employees at work 5 days/week, 6 L/toilet flush, average employee flushes 3 times/day (at work). Sink (31 L/day): Assumes 12 employees, 1.2 L/wash, employees at work 5 days/week, employees use sink 3 times/day.
Potable Water: Workshop	3724 L/day	Includes equipment washdown and sink use. Equipment Washdown (3712 L/day): Assumes 1 hour wash/day, 1.031 L/sec flow rate. Sink (12 L/day): Assumes 1.2 L/wash, 1 sink used 10 times per day.
Potable Water: Old Bath House	24 L/day	Includes sinks facilities. Sinks (24 L/day): Assumes 1.2 L/wash, 2 sinks each used 10 times per day.
Potable Water: New Bath House (Showers, Sink)	8519 L/day	Includes shower and sink facilities (assumes rainwater tank water used for toilets flushing). Shower (8190 L/day): Assumes 9L/min, 10 min/person, average of 91 shift ends / day (calculated from shift information provided by LakeCoal). Sink (329 L/day): Assumes 160 employees, 1.2 L/wash, employees at work 4 days/week, employees use sink 3 times/day.
Potable Water: Conveyor Washdown	11.135 kL/day	Assumes it is used 3 hrs/day, 1.031 L/s flow rate.
Bootwash Water Demand	273 L/day	Assumes it is used 3 L/person/shift, average of 91 shift ends / day (calculated from shift information provided by LakeCoal).
New Bath House Toilet Flushing Demand	1097 L/day	Assumes 160 employees, employees at work 4 days/week, 4 L/toilet flush (reduced for urinals), average employee flushes 3 times/day (at work).
Dust Suppression Demand	11.28 ML/yr	Calculated from available water cart records (3/01/2012 to 11/05/2012).
Combined Rainwater Tank Capacity	30 kL	Proposed rainwater tank capacity from discussions with LakeCoal and commitments made in the WMP.

## 4.0 MODELLING RESULTS

### 4.1 Expected Discharge from Chain Valley Colliery

The probabilistic GoldSim simulation indicated that when applying the historic variation in pumping rates from underground to the predicted 'worst case' average of 10.5 ML/day, the corresponding 95<sup>th</sup> percentile average daily discharge volume of 13.171 ML/day (including pit top runoff) exceeds the daily discharge limit of 12.161 ML/day. The greatest volume calculated in GoldSim using this probabilistic analysis was 14.394 ML/day.

However, as noted in **Section 3.4.4**, LakeCoal are committed to limiting the main underground pumps to a maximum pump out rate of 10.5 ML/day within 12 months of the Proposal being approved. As such, the GoldSim model was run (using a deterministic simulation) assuming that the pumps from the Great Northern Seam sump were constantly pumping at this 10.5 ML/day rate. This scenario assumes that adequate capacity is available in the underground workings to effectively store water during periods when the groundwater inflow rate exceeds the underground dewatering rate. It should be noted that assuming a constant underground pump rate of 10.5 ML/day is a 'worst case' scenario and is only predicted to occur, on occasions, near the end of the Proposal's life.

The daily discharge through LDP1 predicted by GoldSim assuming a constant underground pumping rate of 10.5 ML/day is shown in **Figure 8**.

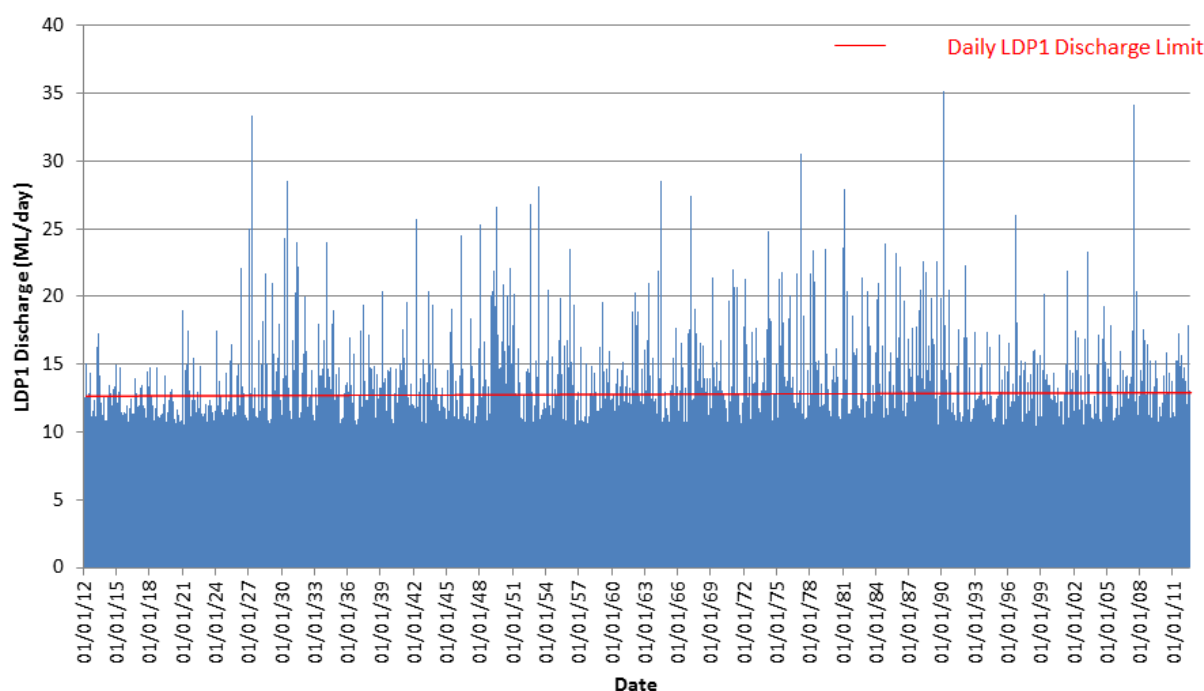

**Figure 8 – LDP1 Discharge Results Assuming Constant Maximum Pumping Rate from Underground**

The results shown in **Figure 8** indicate that if water make from underground is constantly pumped to the surface at 10.5 ML/day then exceedances of the LDP1 limit of 12.161 ML/day will occur regularly.

Key statistics from this GoldSim modelling, assuming a constant discharge from underground of 10.5 ML/day, include:

- Daily average discharge through the LDP1 of 10.716 ML/day;
- Maximum discharge through LDP1 of 35.124 ML/day; and
- Likelihood of LDP1 exceedance on any given day of 4% (or approximately 15 times per year).

These results indicate that underground storages within the Great Northern and Wallarah Seams are required to mitigate peak groundwater inflow rates. In addition, the results indicate that additional storm surge storage capacity is required at the pit top area to effectively mitigate peak runoff flow rates during large rainfall events, even when no pumping from underground occurs during such an event. It is recommended that this issue be managed by the combination of limiting the pump rate from the underground workings to 10.5 ML/day and by seeking an amendment to EPL 1770 to include a condition that allows exceedances of the daily discharge volume limit when 10mm of rainfall has fallen on the premises within the preceding 24 hours. These issues are further described in the SWA report for the Mine Extension 1 Project.

## 4.2 Potable Water Use

### 4.2.1 Potable Water Verification

The total potable water usage, calculated without the proposed water saving measures and from the information provided by LakeCoal, was compared to actual potable water usage records to verify that the assumptions made in these calculations correspond well with the actual usage rates and trends. Results from these calculations indicate that the calculated total potable water use of 132.1 ML/yr compares relatively well to the recent recorded potable water usage (February 2012 to April 2012) of 139 ML/yr. Total potable water usage data from early 2004 was made available for this water balance investigation however only recent usage was used to verify the accuracy of the model assumptions because in recent years the overall usage has been steadily rising as a result of recent miniwall mining methods.

All potable water usage calculations made to verify the model assumptions were associated with the existing operations at Chain Valley Colliery so that the calculated and recorded potable water usage rates could be comparatively compared.

The calculated total potable water used in the pit top area was also compared to the values adopted by AECOM in the previous water balance undertaken for Chain Valley Colliery in 2011. This previous water balance made a 32.7 ML/yr allowance for (the then) future mining activities which are currently undertaken at the mine. The results of this comparison can be seen in **Table 6**.

**Table 6: Comparison of Calculated Total Pit Top Potable Water Usage**

Parameter	Previous (AECOM) Water Balance Value	GSSE Water Balance Value Calculated
Pit Top Potable Water Used (ML/yr)	18.1	20.4
Underground Potable Water Used (ML/yr)	105.0	111.7
Total Potable Water Used (ML/yr)	123.1	132.1
Percentage of Pit Top Potable Water to Total Potable Water Used	14.7%	15.4%

**Table 6** demonstrates that the values adopted in this water balance are similar to those adopted in the previous water balance undertaken by AECOM in 2011. It should be noted that the underground potable water value used in the water balance has no impact on the flow rates discharging from site as this water is accounted for in the metered pumped flows from underground.

#### 4.2.2 Potable Water Savings

The total amount of potable water used at the colliery was investigated in the GoldSim model, with and without the committed water savings measures (as described in **Sections 2.7.1.2**) in order to quantify how much potable water these measures are likely to save at the site. GoldSim modelling estimates that the potable water used in the pit top area will be reduced from 55.9 kL/day to 23.7 kL/day with an overall saving of 32.3 kL/day (11.8 ML/year) as a result of water saving measures being implemented.

This equates to an approximate reduction in total potable water of 8.9% (for current levels of potable water use) and 7.4% (allowing for a 25% increase in the underground potable water use as a result of the proposed future mining works).

Since the potable water used underground is much higher than the potable water used in the pit top area (approximately 85% of the total potable water use) a reduction of the potable water used in the underground mining operations will have more of an effect on the overall potable water used at the site. Such underground potable water saving measures should be investigated to minimise the amount of potable water required from Wyong Council. The potable water saving measures committed to at the pit top area are easily implemented and will also reduce this potable water demand.

#### 4.3 Sensitivity Analysis

A number of assumptions were made in developing the water balance model. This was necessary due to uncertainty associated with the parameters. If available, data from the current operations would normally be used to calibrate the model in order to minimise the uncertainty associated with assumptions. However, as data was not available, a sensitivity analysis was performed on the model to test the impact of potential variability in the assumptions.

The sensitivity analysis entailed varying the value of significant model inputs, such as the water pumped to the surface from underground and the hardstand runoff coefficients at the pit top area. The variability in the model outputs were then observed as a result of these changes to the model inputs. The model outputs which were chosen as indicators were the average and maximum daily discharges as well as the predicted number of LDP1 volume exceedances per year. The results of the sensitivity analysis are provided in **Table 7**.

**Table 7: Sensitivity Analysis Results**

Parameter tested	Lower Bound	Model Value	Upper Bound	Units
<b>Pump rate from underground</b>	7.3 (existing average pump rate)	10.5 (maximum pump rate committed to)	11.75 (current maximum pump rate)	ML/day
- Average Daily Discharge	7.5	10.7	11.9	ML/day
- Maximum Daily Discharge	31.9	35.1	36.3	ML/day
- Estimated Annual Exceedances	3	16	41	Number/year
<b>Hardstand Runoff Coefficient</b>	0.8	0.9 (used in model)	1.0	Dimensionless
- Average Daily Discharge	11.9	11.9	12.0	ML/day
- Maximum Daily Discharge	34.3	36.3	38.5	ML/day
- Estimated Annual Exceedances	39	41	43	Number/year

The results of the sensitivity analysis demonstrate that the relative variability in the hardstand runoff coefficient had little effect on the overall model results. Lowering the constant pumping rate below the maximum possible rate from underground had a significant effect on both the predicted number of exceedances and the average daily discharge from site. It can be seen that the expected average discharge from site dropped at a similar rate to the reduction in the pumping rate which highlights the significance of the pumping rate from underground on the discharges from site and the risk of exceedances. It should be noted however, that the sensitivity analysis did not take into account any operational procedure documenting pumping rules during significant rainfall events. It can also be seen that at the current pumping rate from underground some exceedances of the LDP1 criteria are predicted.

**Table 7** also shows that reducing the pump rate from underground does not have a significant impact on the predicted maximum discharge from site. This indicates that the majority of water discharging from site during these 'extreme' occurrences is due to surface runoff as a result of large rainfall events. As such, LakeCoal should seek an amendment to EPL 1770 to include a condition that allows exceedances of the daily discharge volume limit when 10mm of rainfall has fallen on the premises within the preceding 24 hours.

## 5.0 CONCLUSION

The detailed daily time step water balance was undertaken in GoldSim in order to understand water demands and flows around the pit top area. It was developed to demonstrate that future water management at the mine is sustainable during the Mine Extension 1 Project. A water balance was previously undertaken for the site by AECOM in July 2011. The water balance described in this report was undertaken independently from this previous water balance with only some model inputs compared for verification. This new water balance utilised the outcomes of the Groundwater Assessment Report (Geoterra, 2012) undertaken for the Mine Extension 1 Project and investigated the pit top water use in more detail to aid the future decision making process in regards to water management at the site.

Key findings from this site water balance investigation include the following:

- Potable water used in the pit top area may be reduced by 32.3 kL/day (11.8 ML/year) as a result of proposed water saving measures at the Colliery, including the use of rainwater tanks and the reuse of water within the sedimentation ponds for dust suppression purposes;
- An investigation into the actual available underground storage capacity should be undertaken due to the importance of this storage in regards to the management of water during the life of the Proposal;
- LakeCoal should seek an amendment to EPL 1770 to include a condition that allows exceedances of the daily discharge volume limit when 10mm of rainfall has fallen on the premises within the preceding 24 hours; and
- LakeCoal should commit to limiting the maximum pump out rate from underground to 10.5 ML/day, within 12 months of the Proposal being approved, in order to adhere to aforementioned proposed EPL amendment. The timing of this commitment is due to the substantial upgrades involved with fully automating the pumps and having them controlled by a SCADA system.

## 6.0 REFERENCES

AECOM (2011) – *Environmental Assessment, Chain Valley Colliery Domains 1 and 2 Continuation Project*

AECOM (2011) – *Mine Water Balance. Chain Valley Continuations of Mining*, prepared for LakeCoal.

ANZECC (2000) - *Australian and New Zealand Guidelines for Fresh and Marine Water Quality*.

Bureau of Meteorology (2012) – Evaporation data for weather station 61351 (Peats Ridge (Waratah Road))

Bureau of Meteorology (2012) – Rainfall data for weather station 61366 (Norah Head AWS)

Bureau of Meteorology (2012) – Rainfall data for weather station 61082 (Wyee (Wyee Farms Road))

Department of Environment and Climate Change (DECC) (2008) - *Managing Urban Stormwater: Soils and Construction – Volume 2E Mines and Quarries*, (the Blue Book Volume 2E)

Environmental Protection Authority of New South Wales (2011) - *Environmental Protection License 1770*.

Geoterra (2012) – *Chain Valley Colliery Mine Extension 1 Project, Groundwater Assessment*

GSS Environmental (2012) - *Chain Valley Colliery Water Management Plan, Management System Plan*.

Institution of Engineers Australia (1998) - *Australian Rainfall and Runoff*

LakeCoal (2012) – Coal analysis data

LakeCoal (2012) – Employee shift work records

LakeCoal (2012) – Historic pump flow and water usage spreadsheets

LakeCoal (2008) – *Mine Operation Plan 2008 - 2015*

LakeCoal (2012) – Water cart usage records

LakeCoal (2012) – Water quality database March 2012 spreadsheet

Landcom (2004) - *Managing Urban Stormwater: Soils and Construction – Volume 1, 4<sup>th</sup> Edition*, (the Blue Book Volume 1).

Pearson & Associates (2009) – *Contour/detail survey, settling ponds Chain Valley Colliery, Rutleys Road, Chain Valley Bay*

**Appendix 7: EPL 1770 Water Quality Monitoring Results**

Long term monitoring results from the 2023

Annual review are detailed below.

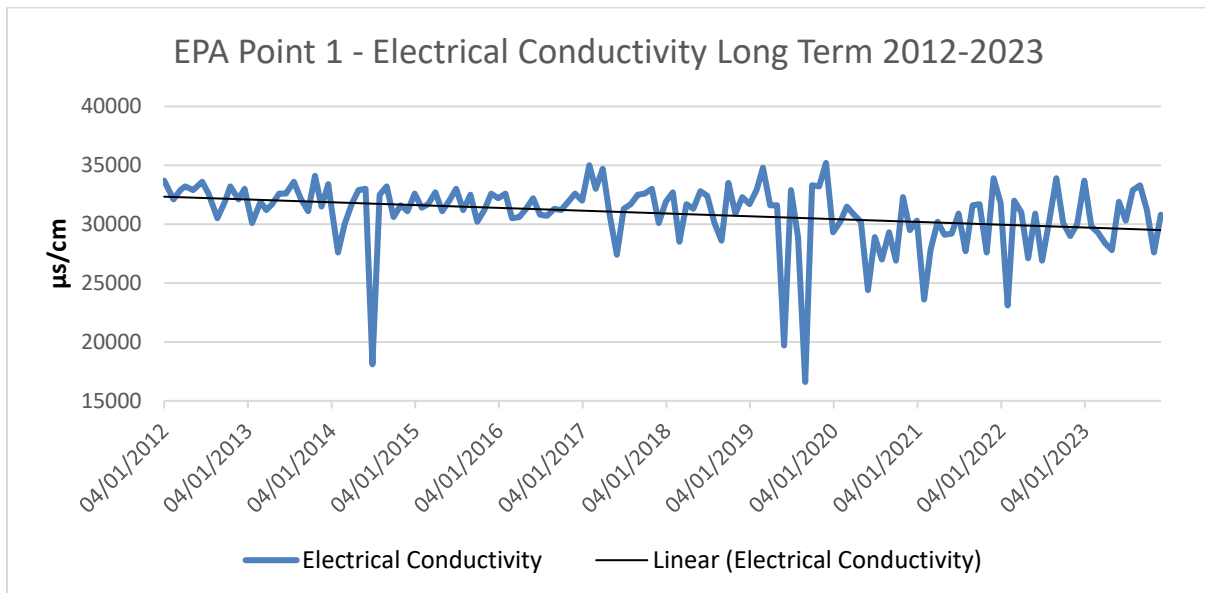
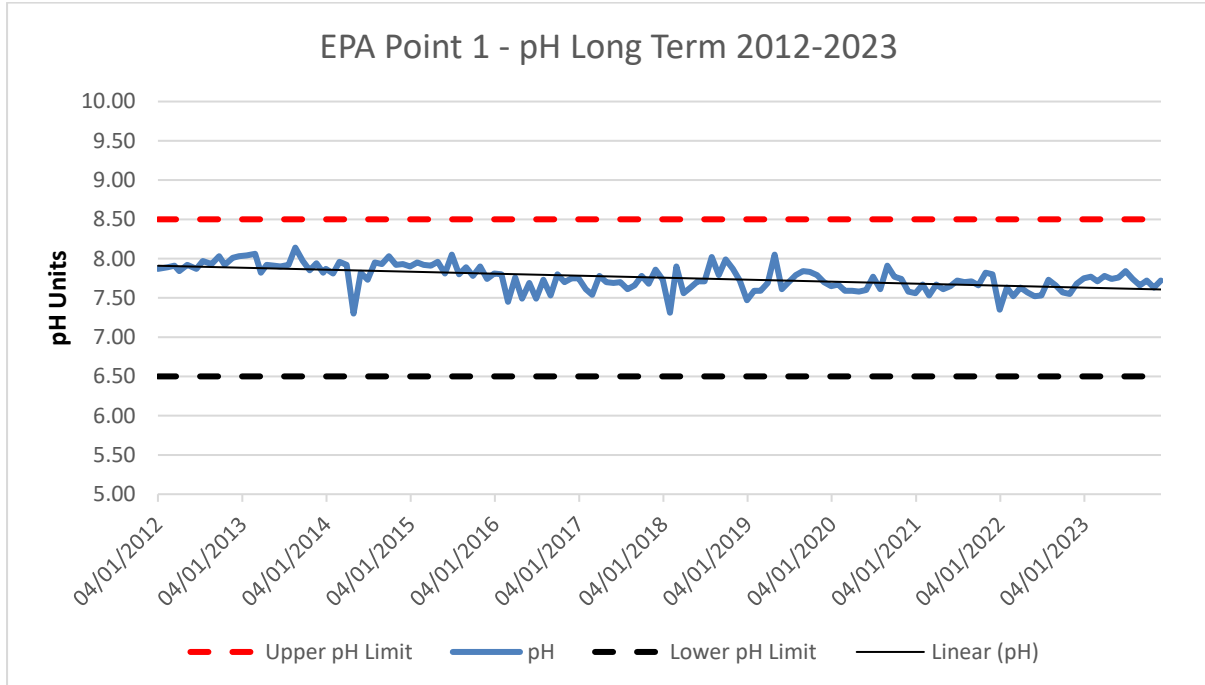

Review Date	Next Review Date	Revision No	Document Owner	Page
16/01/2024	16/01/2027	7	Environmental Compliance and Approvals Coordinator	Page 69 of 75

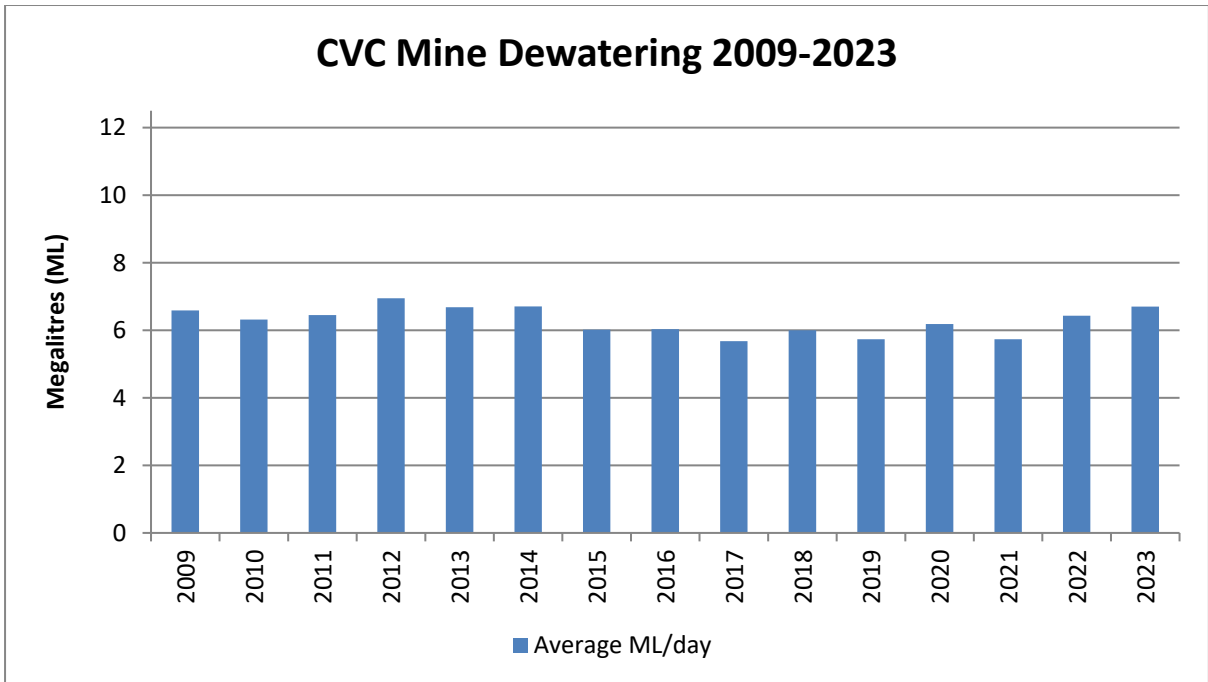
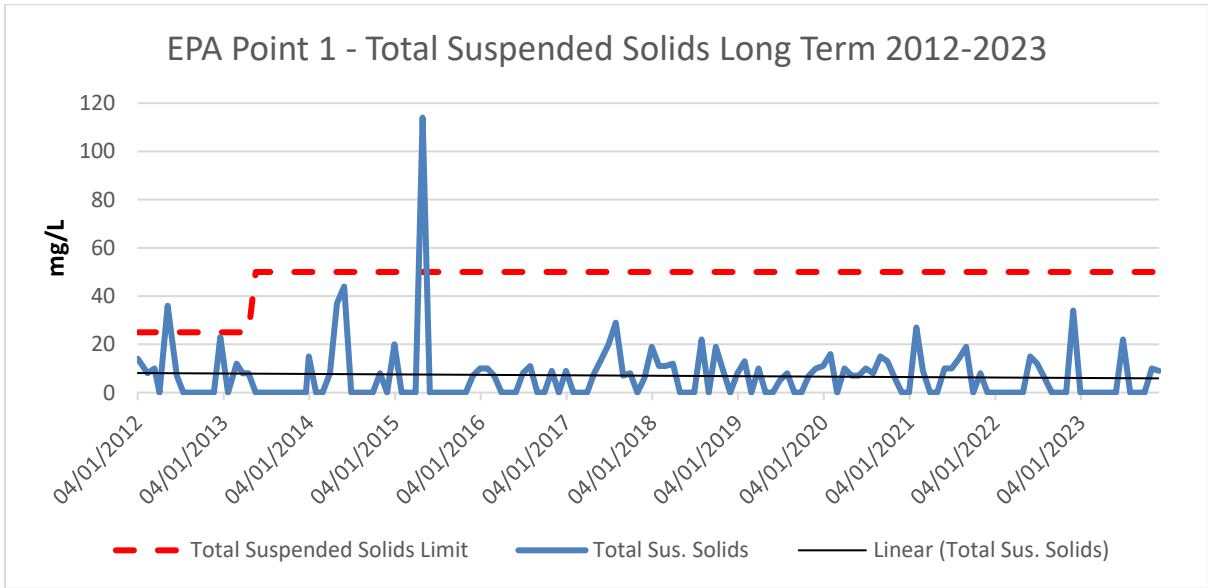

Review Date	Next Review Date	Revision No	Document Owner	Page
16/01/2024	16/01/2027	7	Environmental Compliance and Approvals Coordinator	Page 70 of 75



TITLE Water Management Plan  
DOC ID ENV 00002– Water Management Plan  
SITE Delta Coal

**Appendix 8: 2010-2015 Licensed Discharge Point Water  
Quality Monitoring**

Review Date	Next Review Date	Revision No	Document Owner	Page
16/01/2024	16/01/2027	7	Environmental Compliance and Approvals Coordinator	Page 71 of 75

**DOCUMENT UNCONTROLLED WHEN PRINTED**



**WMP Appendix 8  
Chain Valley Colliery LDP1  
Water Quality Monitoring Data**

	Aug-10	Sep-10	Oct-10	Nov-10	Dec-10	Jan-11	Feb-11	Mar-11	Apr-11	May-11	Jun-11	Jul-11	Aug-11	Sep-11	Oct-11	Nov-11	Dec-11	Jan-12	Feb-12	Mar-12
<b>pH</b>	7.40	7.90	7.30	7.20	7.09	7.75	7.52	8.00	7.73	7.90	7.82	7.89	7.75	7.82	7.84	7.94	7.83	7.95	7.80	7.75
<b>Total Suspended Solids</b>	14.00	12.00	15.00	6.00	5.00	5.00	5.00	5.00	8.00	5.00	5.00	17.00	6.00	5.00	5.00	12.00	5.00	20.00	12.00	10.00
<b>Conductivity</b>	17600.00	20900.00	20900.00	9500.00	12800.00	12500.00	23400.00	28800.00	33700.00	35300.00	36300.00	35000.00	33800.00	33900.00	34300.00	33400.00	33200.00	33400.00	32200.00	32600.00
<b>Total Oil and Grease</b>																				
<b>Faecal Coliforms</b>													12.00		2.00	3.00	26.00	2.00	20.00	6.00
<b>Enterococci</b>																				
<b>Nitrate + Nitrate as N</b>																				
<b>Total Kjeldahl Nitrogen as N</b>																				
<b>Total Nitrogen as N</b>																				
<b>Total Phosphorus</b>	0.08	0.01	0.01	0.01	0.01	0.02	0.10	0.10					0.02	0.01	0.01	0.01	0.02	0.26	0.01	0.01
<b>Total Phosphorus as P</b>																				
<b>Biochemical Oxygen Demand</b>																				
<b>Aluminium (total)</b>	0.37	0.55	1.10	0.49	0.34	0.54	0.36	0.45	0.04	0.06	0.07	0.08	0.01	0.02	0.05	0.04	0.09	0.02	0.01	0.04
<b>Aluminium (soluble)</b>	0.17	0.19	0.07	0.29	0.11	0.46	0.12	0.17	0.04	0.08	0.08	0.02	0.00	0.03	0.01	0.03	0.01	0.01	0.01	0.01
<b>Ammonia as N</b>	0.24	0.00	0.02	0.05	0.10	0.10	0.10	0.10					0.10	0.10	0.10	0.10	0.10	0.02	0.10	0.10
<b>Arsenic (total)</b>	0.0005	0.0005	0.0005	0.0005	0.0005	0.0005	0.0005	0.0012	0.0005	0.0005	0.0005	0.0005	0.0005	0.0005	0.0005	0.0010	0.0011	0.0016	0.0005	0.0005
<b>Arsenic (soluble)</b>	0.0005	0.0005	0.0005	0.0005	0.0005	0.0005	0.0005	0.0008	0.0005	0.0005	0.0005	0.0005	0.0005	0.0005	0.0005	0.0010	0.0010	0.0014	0.0005	0.0005
<b>Beryllium (total)</b>	0.0010	0.0010	0.0010	0.0010	0.0002	0.0001	0.0001	0.0001	0.0001	0.0001	0.0001	0.0001	0.0001	0.0001	0.0001	0.0005	0.0001	0.0001	0.0001	0.0001
<b>Beryllium (soluble)</b>	0.0010	0.0010	0.0010	0.0010	0.0001	0.0001	0.0001	0.0001	0.0001	0.0001	0.0001	0.0001	0.0001	0.0001	0.0001	0.0005	0.0001	0.0001	0.0001	0.0001
<b>Cadmium (total)</b>	0.0010	0.0010	0.0010	0.0010	0.0002	0.0002	0.0002	0.0002	0.0002	0.0002	0.0002	0.0002	0.0002	0.0002	0.0002	0.0003	0.0002	0.0002	0.0002	0.0002
<b>Cadmium (soluble)</b>	0.0010	0.0010	0.0010	0.0010	0.0002	0.0002	0.0002	0.0002	0.0002	0.0002	0.0002	0.0002	0.0002	0.0002	0.0002	0.0003	0.0002	0.0002	0.0002	0.0002
<b>Chromium (total)</b>	0.0500	0.0020	0.0020	0.0020	0.0005	0.0005	0.0005	0.0005	0.0005	0.0005	0.0005	0.0005	0.0005	0.0005	0.0005	0.0010	0.0007	0.0005	0.0005	0.0005
<b>Chromium (soluble)</b>	0.0500	0.0020	0.0020	0.0020	0.0005	0.0005	0.0005	0.0005	0.0006	0.0005	0.0005	0.0005	0.0005	0.0005	0.0005	0.0010	0.0007	0.0005	0.0005	0.0005
<b>Cobalt (total)</b>	0.0070	0.0020	0.0020	0.0020	0.0013	0.0006	0.0008	0.0005	0.0002	0.0002	0.0002	0.0002	0.0002	0.0002	0.0002	0.0002	0.0005	0.0002	0.0002	0.0002
<b>Cobalt (soluble)</b>	0.0070	0.0020	0.0020	0.0020	0.0013	0.0007	0.0005	0.0005	0.0002	0.0002	0.0002	0.0002	0.0002	0.0002	0.0002	0.0005	0.0002	0.0002	0.0002	0.0002
<b>Copper (total)</b>	0.0500	0.0030	0.0300	0.0030	0.0010	0.0010	0.0010	0.0010	0.0010	0.0010	0.0010	0.0010	0.0010	0.0010	0.0010	0.0010	0.0026	0.0010	0.0010	0.0010
<b>Copper (soluble)</b>	0.0500	0.0030	0.0300	0.0030	0.0010	0.0010	0.0010	0.0010	0.0010	0.0010	0.0010	0.0010	0.0010	0.0010	0.0010	0.0025	0.0010	0.0010	0.0010	0.0010
<b>Lead (total)</b>	0.0500	0.0020	0.0030	0.0020	0.0004	0.0002	0.0002	0.0003	0.0002	0.0002	0.0003	0.0002	0.0004	0.0002	0.0002	0.0005	0.0002	0.0002	0.0002	0.0002
<b>Lead (soluble)</b>	0.0500	0.0020	0.0030	0.0020	0.0002	0.0002	0.0002	0.0002	0.0002	0.0004	0.0002	0.0002	0.0002	0.0002	0.0002	0.0005	0.0002	0.0002	0.0002	0.0003
<b>Mercury (total)</b>	0.0005	0.0005	0.0011	0.0005	0.0000	0.0000	0.0000	0.0000	0.0000	0.0000	0.0000	0.0000	0.0000	0.0000	0.0000	0.0000	0.0000	0.0000	0.0000	0.0000
<b>Mercury (soluble)</b>	0.0005	0.0005	0.0005	0.0005	0.0000	0.0000	0.0000	0.0000	0.0000	0.0000	0.0000	0.0000	0.0000	0.0000	0.0000	0.0000	0.0000	0.0000	0.0000	0.0000
<b>Molybdenum (total)</b>	0.0190	0.0090	0.0080	0.0040	0.0034	0.0082	0.0107	0.0242	0.0011	0.0027	0.0022	0.0026	0.0021	0.0016	0.0020	0.0024	0.0025	0.0030	0.0018	0.0025
<b>Molybdenum (soluble)</b>	0.0110	0.0090	0.0070	0.0040	0.0027	0.0061	0.0113	0.0243	0.0016	0.0013	0.0015	0.0026	0.0001	0.0018	0.0018	0.0021	0.0023	0.0028	0.0008	0.0023
<b>Nickel (total)</b>	0.0500	0.0020	0.0020	0.0020	0.0056	0.0078	0.0064	0.0091	0.0016	0.0014	0.0021	0.0010	0.0010	0.0005	0.0013	0.0026	0.0007	0.0005	0.0006	0.0005
<b>Nickel (soluble)</b>	0.0500	0.0020	0.0020	0.0020	0.0045	0.0069	0.0072	0.0091	0.0005	0.0027	0.0017	0.0011	0.0005	0.0007	0.0005	0.0025	0.0009	0.0006	0.0005	0.0010
<b>Selenium (total)</b>	0.0005	0.0005	0.0005	0.0005	0.0020	0.0020	0.0020	0.0020	0.0020	0.0020	0.0020	0.0020	0.0020	0.0020	0.0020	0.0010	0.0020	0.0020	0.0020	0.0020
<b>Selenium (soluble)</b>	0.0005	0.0005	0.0005	0.0005	0.0020	0.0020	0.0020	0.0020	0.0020	0.0020	0.0020	0.0020	0.0020	0.0020	0.0020	0.0010	0.0020	0.0020	0.0020	0.0020
<b>Silver (total)</b>	0.0010	0.0040	0.0040	0.0010	0.0001	0.0001	0.0001	0.0001	0.0001	0.0001	0.0001	0.0001	0.0001	0.0001	0.0001	0.0005	0.0001	0.0001	0.0001	0.0001
<b>Silver (soluble)</b>	0.0010	0.0030	0.0040	0.0010	0.0001	0.0001	0.0001	0.0001	0.0001	0.0001	0.0001	0.0001	0.0001	0.0001	0.0001	0.0005	0.0001	0.0001	0.0001	0.0001
<b>Vanadium (total)</b>					0.0005	0.0005	0.0005	0.0005	0.0007	0.0005	0.0005	0.0005	0.0005	0.0005	0.0005	0.0016	0.0005	0.0005	0.0005	0.0005
<b>Vanadium (soluble)</b>					0.0005	0.0007	0.0005	0.0005	0.0005	0.0005	0.0005	0.0005	0.0005	0.0005	0.0005	0.0016	0.0005	0.0005	0.0005	0.0005
<b>Zinc (total)</b>	0.0500	0.0100	0.0090	0.0110	0.0130	0.0050	0.0100	0.0100	0.0090	0.0130	0.0350	0.0240	0.0180	0.0220	0.0140	0.0220	0.0270	0.0740	0.0360	0.0220
<b>Zinc (soluble)</b>	0.0500	0.0100	0.0090	0.0110	0.0100	0.0060	0.0050	0.0050	0.0090	0.0160	0.0280	0.0180	0.0180	0.0200	0.0120	0.0050	0.0280	0.0650	0.0190	0.0300
<b>Anionic Surfactants as MBAS</b>													0.40		0.10	0.10	0.10	0.10	0.10	0.20



**WMP Appendix 8  
Chain Valley Colliery LDP1  
Water Quality Monitoring Data**

	Apr-12	May-12	Jun-12	Jul-12	Aug-12	Sep-12	Oct-12	Nov-12	Dec-12	Jan-13	Feb-13	Mar-13	Apr-13	May-13	Jun-13	Jul-13	Aug-13	Sep-13	Oct-13	Nov-13	Dec-13	Jan-14	Feb-14	Mar-14	Apr-14	May-14	
<b>pH</b>	7.73	7.82	7.74	7.89	7.77	8.01	7.82	7.91	7.95	7.97	7.97	7.63	7.82	7.77	7.72	7.70	8.01	7.83	7.71	7.75	7.69	7.73	7.54	7.84	7.75		
<b>Total Suspended Solids</b>	5.00	20.00	7.00	5.00	5.00	5.00	5.00	5.00	42.00	5.00	8.00	12.00	8.00	5.00	5.00	5.00	5.00	5.00	5.00	5.00	5.00	5.00	5.00	5.00	5.00		
<b>Conductivity</b>	32700.00	32900.00	33500.00	32700.00	30500.00	31900.00	32900.00	32100.00	32700.00	30200.00	31500.00	31100.00	31700.00	32700.00	32800.00	33600.00	32100.00	31200.00	32900.00	31600.00	33400.00	32700.00	28900.00	29900.00	26100.00	32900.00	
<b>Total Oil and Grease</b>					5.00	5.00	5.00	5.00	5.00	5.00	5.00	5.00	5.00	5.00	5.00	5.00	5.00	5.00	5.00	5.00	5.00	5.00	5.00	5.00	5.00		
<b>Faecal Coliforms</b>	46.00	18.00	50.00	26.00	37.00	12.00	28.00	19.00	1.00	23.00	14.00	28.00	4.00	38.00	63.00	96.00	120.00	18.00	22.00	32.00	7.00	25.00	250.00	3.00	180.00	9.00	
<b>Enterococci</b>						8.00	14.00	10.00	1.00	14.00	64.00	33.00	100.00	90.00	380.00	440.00	830.00	110.00	56.00	50.00	17.00	13.00	150.00	8.00	130.00	9.00	
<b>Nitrate + Nitrate as N</b>						0.25	0.30	0.29	0.22	0.31	0.14	0.13	0.14	0.24	0.22	0.50	4.33	0.38	0.43	0.37	0.35	0.34	0.18	0.18	0.44	0.39	
<b>Total Kjeldahl Nitrogen as N</b>						0.40	0.20	0.20	0.10	0.10	0.20	0.60	0.10	0.20	0.10	0.50	0.50	0.10	0.20	0.40	0.70	0.50	0.50	0.20	0.50	0.50	
<b>Total Nitrogen as N</b>						0.60	0.50	0.50	0.30	0.30	0.10	0.70	0.20	0.40	0.30	0.50	4.30	0.40	0.60	0.80	1.00	0.30	0.50	0.20	0.40	0.50	
<b>Total Phosphorus</b>	0.30	0.04	0.01	0.01	0.04	0.01	0.01	0.01	0.01	0.01	0.01	0.01	0.01	0.01	0.01	0.05	0.05	0.01	0.01	0.02	0.14	0.05	0.05	0.02	0.05	0.05	
<b>Total Phosphorus as P</b>						0.01	0.01	0.01	0.01	0.01	0.01	0.01	0.01	0.01	0.01	0.05	0.05	0.01	0.01	0.02	0.14	0.05	0.05	0.02	0.05	0.05	
<b>Biochemical Oxygen Demand</b>						2.00	2.00	2.00	2.00	2.00	2.00	2.00	2.00	2.00	2.00	2.00	2.00	2.00	2.00	2.00	2.00	2.00	2.00	2.00	2.00	2.00	
<b>Aluminium (total)</b>	0.03	0.03	0.01	0.03	0.08	0.05	0.06	0.06	0.04	0.05	0.02	0.03	0.03	0.06	0.05	0.04	0.07	0.02	0.04	0.09	0.02	0.10	0.09	0.05	0.08	0.06	
<b>Aluminium (soluble)</b>	0.01	0.01	0.01	0.01	0.01	0.18	0.01	0.01	0.04	0.01	0.03	0.01	0.01	0.01	0.05	0.01	0.07	0.02	0.04	0.01	0.01	0.10	0.02	0.01	0.01	0.01	
<b>Ammonia as N</b>	0.08	0.14	0.10	0.10	0.10	0.10	0.10	0.10	0.10	0.10	0.10	0.05	0.05	0.08	0.06	0.18	0.11		0.11	0.16	0.10	0.09	0.12	0.06	0.06	0.12	
<b>Arsenic (total)</b>	0.0005	0.0005	0.0005	0.0005	0.0006	0.0005	0.0005	0.0006	0.0005	0.0015	0.0005	0.0005	0.0007	0.0005	0.0005	0.0005	0.0005	0.0005	0.0005	0.0005	0.0020	0.0000	0.0000	0.0030	0.0020	0.0010	
<b>Arsenic (soluble)</b>	0.0005	0.0005	0.0005	0.0005	0.0007	0.0005	0.0005	0.0006	0.0005	0.0013	0.0005	0.0005	0.0007	0.0005	0.0005	0.0005	0.0005	0.0005	0.0005	0.0005	0.0010	0.0000	0.0000	0.0010	0.0010	0.0010	
<b>Beryllium (total)</b>	0.0001	0.0001	0.0001	0.0001	0.0001	0.0001	0.0001	0.0001	0.0001	0.0001	0.0001	0.0001	0.0001	0.0001	0.0001	0.0001	0.0001	0.0001	0.0001	0.0001	0.0010	0.0000	0.0000	0.0010	0.0010	0.0010	
<b>Beryllium (soluble)</b>	0.0001	0.0001	0.0001	0.0001	0.0001	0.0001	0.0001	0.0001	0.0001	0.0001	0.0001	0.0001	0.0001	0.0001	0.0001	0.0001	0.0001	0.0001	0.0001	0.0001	0.0010	0.0000	0.0000	0.0010	0.0010	0.0010	
<b>Cadmium (total)</b>	0.0002	0.0002	0.0002	0.0002	0.0002	0.0002	0.0002	0.0002	0.0002	0.0002	0.0002	0.0002	0.0002	0.0002	0.0002	0.0002	0.0002	0.0002	0.0002	0.0002	0.0002	0.0002	0.0002	0.0001	0.0001	0.0001	
<b>Cadmium (soluble)</b>	0.0002	0.0002	0.0002	0.0002	0.0002	0.0002	0.0002	0.0002	0.0002	0.0002	0.0002	0.0002	0.0002	0.0002	0.0002	0.0002	0.0002	0.0002	0.0002	0.0002	0.0002	0.0002	0.0001	0.0000	0.0001	0.0001	
<b>Chromium (total)</b>	0.0005	0.0005	0.0005	0.0005	0.0005	0.0005	0.0005	0.0005	0.0005	0.0005	0.0005	0.0005	0.0005	0.0005	0.0005	0.0005	0.0005	0.0005	0.0005	0.0005	0.0010	0.0100	0.0010	0.0010	0.0020	0.0010	
<b>Chromium (soluble)</b>	0.0005	0.0005	0.0005	0.0005	0.0005	0.0005	0.0005	0.0005	0.0005	0.0005	0.0005	0.0005	0.0005	0.0005	0.0005	0.0005	0.0005	0.0005	0.0005	0.0005	0.0010	0.0100	0.0010	0.0010	0.0010	0.0010	
<b>Cobalt (total)</b>	0.0002	0.0002	0.0002	0.0002	0.0002	0.0002	0.0002	0.0002	0.0002	0.0002	0.0002	0.0002	0.0002	0.0002	0.0002	0.0002	0.0002	0.0002	0.0002	0.0002	0.0002	0.0010	0.0000	0.0000	0.0010	0.0010	
<b>Cobalt (soluble)</b>	0.0002	0.0002	0.0002	0.0002	0.0002	0.0002	0.0002	0.0002	0.0002	0.0002	0.0002	0.0002	0.0002	0.0002	0.0002	0.0002	0.0002	0.0002	0.0002	0.0002	0.0002	0.0010	0.0000	0.0000	0.0010	0.0010	
<b>Copper (total)</b>	0.0010	0.0010	0.0010	0.0010	0.0010	0.0010	0.0010	0.0010	0.0010	0.0010	0.0010	0.0010	0.0030	0.0010	0.0010	0.0010	0.0010	0.0010	0.0010	0.0010	0.0010	0.0010	0.0010	0.0010	0.0010	0.0010	
<b>Copper (soluble)</b>	0.0010	0.0010	0.0010	0.0010	0.0010	0.0010	0.0010	0.0010	0.0010	0.0010	0.0010	0.0010	0.0010	0.0010	0.0010	0.0010	0.0010	0.0010	0.0010	0.0020	0.0010	0.0010	0.0010	0.0010	0.0010	0.0010	
<b>Lead (total)</b>	0.0002	0.0002	0.0002	0.0002	0.0002	0.0002	0.0002	0.0002	0.0002	0.0002	0.0002	0.0002	0.0002	0.0002	0.0002	0.0002	0.0002	0.0002	0.0002	0.0002	0.0002	0.0002	0.0002	0.0002	0.0002	0.0002	
<b>Lead (soluble)</b>	0.0002	0.0002	0.0002	0.0002	0.0002	0.0002	0.0002	0.0002	0.0002	0.0002	0.0002	0.0002	0.0002	0.0002	0.0002	0.0002	0.0002	0.0002	0.0002	0.0002	0.0002	0.0002	0.0002	0.0002	0.0002	0.0002	
<b>Mercury (total)</b>	0.0000	0.0000	0.0000	0.0000	0.0000	0.0000	0.0000	0.0000	0.0000	0.0000	0.0000	0.0000	0.0000	0.0000	0.0000	0.0000	0.0000	0.0000	0.0000	0.0000	0.0000	0.0000	0.0000	0.0001	0.0001	0.0001	
<b>Mercury (soluble)</b>	0.0000	0.0000	0.0000	0.0000	0.0000	0.0000	0.0000	0.0000	0.0000	0.0000	0.0000	0.0000	0.0000	0.0000	0.0000	0.0000	0.0000	0.0000	0.0000	0.0000	0.0000	0.0000	0.0000	0.0001	0.0001	0.0001	
<b>Molybdenum (total)</b>	0.0022	0.0032	0.0027	0.0024	0.0022	0.0026	0.0024	0.0028	0.0014	0.0026	0.0029	0.0025	0.0030	0.0029	0.0026	0.0029	0.0024	0.0021	0.0019	0.0043	0.0040	0.0000	0.0000	0.0060	0.0070	0.0030	
<b>Molybdenum (soluble)</b>	0.0018	0.0028	0.0028	0.0028	0.0024	0.0022	0.0023	0.0028	0.0017	0.0024	0.0029	0.0026	0.0024	0.0024	0.0026	0.0027	0.0024	0.0021	0.0016	0.0038	0.0030	0.0000	0.0000	0.0060	0.0060	0.0030	
<b>Nickel (total)</b>	0.0005	0.0005	0.0010	0.0010	0.0009	0.0005	0.0006	0.0008	0.0007	0.0012	0.0010	0.0009	0.0018	0.0011	0.0015	0.0017	0.0014	0.0014	0.0012	0.0014	0.0010	0.0100	0.0020	0.0020	0.0040	0.0030	
<b>Nickel (soluble)</b>	0.0005	0.0009	0.0006	0.0014	0.0009	0.0006	0.0005	0.0009	0.0007	0.0014	0.0009	0.0009	0.0012	0.0014	0.0012	0.0016	0.0016	0.0009	0.0011	0.0015	0.0010	0.0100	0.0020	0.0020	0.0040	0.0030	
<b>Selenium (total)</b>	0.0020	0.0020	0.0020	0.0020	0.0020	0.0020	0.0020	0.0020	0.0020	0.0020	0.0020	0.0020	0.0130	0.0020	0.0020	0.0020	0.0020	0.0020	0.0020	0.0020	0.0300	0.0001	0.0100	0.0300	0.0100	0.0100	
<b>Selenium (soluble)</b>	0.0020	0.0020	0.0020	0.0020	0.0020	0.0020	0.0020	0.0020	0.0020	0.0020	0.0020	0.0020	0.0080	0.0020	0.0020	0.0020	0.0020	0.0020	0.0020	0.0020	0.0020	0.0100	0.0001	0.0100	0.0300	0.0100	
<b>Silver (total)</b>	0.0001	0.0001	0.0001	0.0001	0.0001	0.0001	0.0001	0.0001	0.0001	0.0001	0.0001	0.0001	0.0001	0.0001	0.0001	0.0001	0.0001	0.0001	0.0001	0.0001	0.0001	0.0100	0.0000	0.0000	0.0060	0.0010	0.0020
<b>Silver (soluble)</b>	0.0001	0.0001	0.0001	0.0001	0.0001	0.0001	0.0001	0.0001	0.0001	0.0001	0.0001	0.0001	0.0001	0.0001	0.0001	0.0001	0.0001	0.0001	0.0001	0.0001	0.0100	0.0000	0.0000	0.0060	0.0010	0.0040	
<b>Vanadium (total)</b>	0.0005	0.0005	0.0005	0.0005	0.0005	0.0015	0.0005	0.0005	0.0005	0.0005	0.0005	0.0005	0.0005	0.0005	0.0005	0.0005	0.0005	0.0005	0.0005	0.0020	0.0009	0.0100	0.0100	0.0100	0.0100	0.0100	
<b>Vanadium (soluble)</b>	0.0005	0.0011	0.0005	0.0005	0.0005	0.0016	0.0005	0.0005	0.0005	0.0005	0.0005	0.0005	0.0005	0.0005	0.0005	0.0005	0.0005	0.0005	0.0005	0.0005	0.0007	0.0100	0.0100	0.0100	0.0100	0.0100	
<b>Zinc (total)</b>	0.0150	0.0160	0.0160	0.0180	0.0250	0.0220	0.0200	0.0190	0.0220	0.0360	0.0160																



**WMP Appendix 8  
Chain Valley Colliery LDP1  
Water Quality Monitoring Data**

	Jun-14	Jul-14	Aug-14	Sep-14	Oct-14	Nov-14	Dec-14	Jan-15	Feb-15	Mar-15	Apr-15	May-15	Jun-15	Jul-15		Count	Avg	Min	Max
pH		7.81	7.83	7.81	7.90	7.92	7.80	7.66	7.83	7.81	7.75	7.8	7.81	8.05		58	7.78	7.09	8.05
Total Suspended Solids	42.00	5.00	5.00	5.00	5.00	5.00	5.00	5.00	5.00	5.00	5	106	5	5		60	9.70	5.00	106.00
Conductivity		31100.00	32600.00	33400.00	30200.00	31100.00	31200.00	32800.00	31400.00	31700.00	32700	31200	32000	33000		59	30425	9500.00	36300.00
Total Oil and Grease	5.00	5.00	5.00	5.00	5.00	5.00	5.00	5.00	5.00	5.00	5	5	5	5		35	5.0000	5.00	5.00
Faecal Coliforms	16.00	12.00	100.00	40.00	4.00	4.00	2.00	5.00	11.00	7.00	9	27	47	2		47	32.4681	1.00	250.00
Enterococci	180.00	50.00	150.00	23.00	220.00	11.00	2.00	13.00	35.00	60.00	18	44	56	5		35	97.0857	2.00	830.00
Nitrate + Nitrate as N	0.56	0.60	0.48	0.46	0.54	0.30	0.42	0.39	0.44	0.38	0.37	0.38	1	0.56		35	0.4860	0.13	4.33
Total Kjeldahl Nitrogen as N	0.02	0.20	0.20	0.20	0.20	0.20	0.20	0.20	0.20	0.20	0.2	0.2	0.2	0.5		35	0.2777	0.02	0.70
Total Nitrogen as N	0.60	0.60	0.50	0.50	0.50	0.30	0.40	0.40	0.40	0.40	0.4	0.4	1.2	1.1		35	0.6029	0.10	4.30
Total Phosphorus	0.02	0.02	0.05	0.02	0.02	0.06	0.02	0.02	0.02	0.12	0.02	0.04	0.02	0.02		56	0.0402	0.01	0.30
Total Phosphorus as P	0.02	0.02	0.05	0.02	0.02	0.06	0.02	0.02	0.02	0.12	0.02	0.04	0.02	0.02		35	0.0377	0.01	0.26
Biochemical Oxygen Demand	2.00	2.00	2.00	2.00	2.00	2.00	2.00	2.00	3.00	2.00	2	2	2	2		35	2.0286	2.00	3.00
Aluminium (total)	0.01	0.08	0.08	0.10	0.10	0.10	0.03	0.10	0.05	0.10	0.1	0.1	0.1	0.1		60	0.1196	0.01	1.10
Aluminium (soluble)	0.01	0.01	0.01	0.10	0.10	0.10	0.01	0.10	0.06	0.01						56	0.0554	0.00	0.46
Ammonia as N	0.17	0.09	0.08	0.05	0.09	0.03	0.04	0.03	0.01	0.05	0.01	0.08	0.04	0.07		55	0.0861	0.00	0.24
Arsenic (total)	0.0100	0.0010	0.0010	0.0100	0.0100	0.0100	0.0010	0.0100	0.0050	0.0100	0.0100	0.0100	0.0100	0.0100		60	0.0023	0.00	0.01
Arsenic (soluble)	0.0100	0.0010	0.0010	0.0100	0.0100	0.0100	0.0010	0.0100	0.0080	0.0010	0.0100	0.0100	0.0100	0.0100		60	0.0022	0.00	0.01
Beryllium (total)	0.0100	0.0010	0.0010	0.0100	0.0100	0.0100	0.0010	0.0100	0.0050	0.0100	0.0100	0.0100	0.0100	0.0100		60	0.0020	0.00	0.01
Beryllium (soluble)	0.0100	0.0010	0.0010	0.0100	0.0100	0.0100	0.0010	0.0100	0.0050	0.0010	0.0100	0.0100	0.0100	0.0100		60	0.0019	0.00	0.01
Cadmium (total)	0.0010	0.0001	0.0002	0.0010	0.0010	0.0010	0.0001	0.0010	0.0005	0.0010	0.0010	0.0010	0.0010	0.0010		60	0.0004	0.00	0.00
Cadmium (soluble)	0.0010	0.0001	0.0001	0.0010	0.0010	0.0010	0.0001	0.0010	0.0005	0.0001	0.0010	0.0010	0.0010	0.0010		60	0.0004	0.00	0.00
Chromium (total)	0.0100	0.0010	0.0010	0.0100	0.0100	0.0100	0.0010	0.0100	0.0050	0.0100	0.0100	0.0100	0.0100	0.0100		60	0.0033	0.00	0.05
Chromium (soluble)	0.0100	0.0010	0.0010	0.0100	0.0100	0.0100	0.0010	0.0100	0.0050	0.0010	0.0010	0.0010	0.0010	0.0010		60	0.0025	0.00	0.05
Cobalt (total)	0.0100	0.0010	0.0010	0.0100	0.0100	0.0100	0.0010	0.0100	0.0050	0.0100	0.0010	0.0010	0.0010	0.0010		60	0.0016	0.00	0.01
Cobalt (soluble)	0.0100	0.0010	0.0010	0.0100	0.0100	0.0100	0.0010	0.0100	0.0050	0.0010	0.0010	0.0010	0.0010	0.0010		60	0.0015	0.00	0.01
Copper (total)	0.0100	0.0010	0.0010	0.0100	0.0100	0.0100	0.0010	0.0200	0.0630	0.0100	0.0100	0.0100	0.0100	0.0100		60	0.0051	0.00	0.06
Copper (soluble)	0.0100	0.0010	0.0010	0.0100	0.0100	0.0100	0.0010	0.0100	0.0140	0.0010	0.0100	0.0100	0.0100	0.0100		60	0.0040	0.00	0.05
Lead (total)	0.0100	0.0010	0.0010	0.0100	0.0100	0.0100	0.0010	0.0100	0.0050	0.0100	0.0100	0.0100	0.0100	0.0100		60	0.0030	0.00	0.05
Lead (soluble)	0.0100	0.0010	0.0010	0.0100	0.0100	0.0100	0.0010	0.0100	0.0050	0.0010	0.0100	0.0100	0.0100	0.0100		60	0.0028	0.00	0.05
Mercury (total)	0.0001	0.0001	0.0001	0.0001	0.0001	0.0001	0.0001	0.0001	0.0001	0.0001	0.0001	0.0001	0.0001	0.0001		60	0.0001	0.00	0.00
Mercury (soluble)	0.0001	0.0001	0.0001	0.0001	0.0001	0.0001	0.0001	0.0001	0.0001	0.0001	0.0001	0.0001	0.0001	0.0001		60	0.0001	0.00	0.00
Molybdenum (total)	0.0100	0.0020	0.0060	0.0100	0.0100	0.0100	0.0050	0.0100	0.0050	0.0100	0.0100	0.0100	0.0100	0.0100		60	0.0051	0.00	0.02
Molybdenum (soluble)	0.0100	0.0020	0.0040	0.0100	0.0100	0.0100	0.0040	0.0100	0.0080	0.0020	0.0100	0.0100	0.0100	0.0100		60	0.0045	0.00	0.02
Nickel (total)	0.0100	0.0020	0.0030	0.0100	0.0100	0.0100	0.0020	0.0100	0.0050	0.0100	0.0100	0.0100	0.0100	0.0100		60	0.0042	0.00	0.05
Nickel (soluble)	0.0100	0.0020	0.0020	0.0100	0.0100	0.0100	0.0020	0.0100	0.0070	0.0010	0.0100	0.0100	0.0100	0.0100		60	0.0041	0.00	0.05
Selenium (total)	0.1000	0.0200	0.0100	0.1000	0.1000	0.1000	0.0100	0.1000	0.0500	0.1000	0.1000	0.1000	0.1000	0.1000		60	0.0212	0.00	0.10
Selenium (soluble)	0.1000	0.0100	0.0100	0.1000	0.1000	0.1000	0.0100	0.1000	0.0500	0.0100	0.1000	0.1000	0.1000	0.1000		60	0.0190	0.00	0.10
Silver (total)	0.0100	0.0010	0.0010	0.0100	0.0100	0.0100	0.0100	0.0100	0.0050	0.0100	0.0100	0.0100	0.0100	0.0100		60	0.0025	0.00	0.01
Silver (soluble)	0.0100	0.0010	0.0010	0.0100	0.0100	0.0100	0.0100	0.0100	0.0050	0.0010	0.0100	0.0100	0.0100	0.0100		60	0.0024	0.00	0.01
Vanadium (total)	0.0100	0.0100	0.0100	0.1000	0.1000	0.1000	0.0100	0.1000	0.0500	0.1000	0.1000	0.1000	0.1000	0.1000		56	0.0208	0.00	0.10
Vanadium (soluble)	0.0100	0.0100	0.0100	0.1000	0.1000	0.1000	0.0100	0.1000	0.0500	0.0100	0.1000	0.1000	0.1000	0.1000		56	0.0191	0.00	0.10
Zinc (total)	0.0520	0.0330	0.0560	0.0500	0.0790	0.0500	0.0380	0.1040	0.1310	0.0550	0.1470	0.0940	0.0940	0.0500		60	0.0404	0.01	0.15
Zinc (soluble)	0.0500	0.0340	0.0400	0.0500	0.0570	0.0500	0.0440	0.0750	0.0400	0.0470	0.1120	0.0680	0.0680	0.0500		60	0.0336	0.01	0.11
Anionic Surfactants as MBAS	0.10	0.10	0.10	0.10	0.10	0.10	0.10	0.10	0.10	0.10	0.1	0.1	0.1	0.1		47	0.1702	0.10	1.30



TITLE Water Management Plan  
DOC ID ENV 00002– Water Management Plan  
SITE Delta Coal

**Appendix 9: Water Management TARP**

Review Date	Next Review Date	Revision No	Document Owner	Page
16/01/2024	16/01/2027	7	Environmental Compliance and Approvals Coordinator	Page 72 of 75

**DOCUMENT UNCONTROLLED WHEN PRINTED**



# Trigger Action Resp Plan CVC Water Management

## TARP 00089 - CVC Water Management

<b>TARP TITLE</b>	<b>TARP 00089 Water Management</b>
-------------------	------------------------------------

	Normal	Trigger 1	Trigger 2
<b>1. FASSI PRODUCTION FACE OR PANEL WATER MAKE</b>	<ul style="list-style-type: none"> <li>Face water make normal and able to be managed with existing panel pumping arrangements</li> </ul>	<ul style="list-style-type: none"> <li>Face water make excessive / unable to be managed with existing panel pumping arrangements</li> </ul>	<ul style="list-style-type: none"> <li>Uncontrollable ingress of water likely to cause serious injury to persons or damage to equipment</li> </ul>
<b>ACTIONS</b>	<p>Manage face water via relevant panel tarps – continue mining activities in compliance with Roadway TARP</p> <p>Ensure pumping equipment is available for use</p>	<ol style="list-style-type: none"> <li>Cease production</li> <li>Ensure mobile and fixed plant is in a safe location where possible (remove/ isolate from potential flooding locations)</li> <li>Withdraw affected persons to a safe location</li> <li>Mobilise sufficient pumping equipment</li> <li>Set up / monitor pumping equipment to manage water make</li> <li>Notify CRO and Shift Undermanager</li> </ol>	<ol style="list-style-type: none"> <li>Initiate emergency response plan as required, including withdrawal of workers to a place of safety</li> <li>Initiate the IMT</li> <li>Notify Mine Manager and Production Manager</li> </ol>
	Normal	Trigger 1	Trigger 2
<b>2. FASSIFERN SEAM (OUTBYE) WATER MAKE</b>	<ul style="list-style-type: none"> <li>Outbye areas of water make able to be managed via existing pumping arrangements, AND</li> <li>Fassifern Seam daily average not exceeding long term trend (&lt;1000 kL daily average)</li> </ul>	<ul style="list-style-type: none"> <li>Signs of localised increased water make, unable to be managed with existing pumping arrangements OR</li> <li>Fassifern Seam daily average exceeding long term trend of 1000 kL daily average but able to be managed with existing system</li> </ul>	<ul style="list-style-type: none"> <li>Fassifern Seam water make unable to be managed with existing pumping system AND</li> <li>There is an immediate risk to the safety of workers and the mine.</li> </ul>
<b>ACTIONS</b>	<ol style="list-style-type: none"> <li>Real time monitoring of Fassi total pump out</li> <li>Weekly / Daily inspections</li> <li>Weekly pumping work order including CVB1 pressure reading</li> <li>Weekly review of UG daily dewatering volumes against averages (Work Order System)</li> </ol>	<ol style="list-style-type: none"> <li>Notify CRO and Undermanager</li> <li>Increase inspection frequency in affected area(s)</li> <li>Review requirements for additional pumping equipment or storage areas</li> </ol>	<ol style="list-style-type: none"> <li>Inform Production Manager and Mine Manager</li> <li>Cease production</li> <li>Ensure face equipment is in a safe location where possible (away from potential flooding locations)</li> <li>Withdraw affected persons to a safe location</li> <li>Mobilise sufficient pumping equipment</li> <li>Set up / monitor pumping equipment to manage water make</li> <li>Initiate the IMT</li> </ol>

LAST REVIEW DATE	NEXTREVIEW DATE	REVISION NO	DOCUMENT OWNER	
19/10/2021	19/10/2024	9	Technical Services Manager	PAGE 1 of 6



# Trigger Action Resp Plan CVC Water Management

## TARP 00089 - CVC Water Management

	Normal	Trigger 1	Trigger 2
<b>3. CHAIN VALLEY BAY (CVB) GOAF WATER STORAGE</b>	<ul style="list-style-type: none"> <li>&lt;38kPa static borehole pressure, AND</li> <li>No evidence of water accumulation around CVB1 seals, AND</li> <li>&gt;200mm roof gap above water level in CVB1 gate road (ventilation) , AND</li> <li>No increasing water make around Fassifern seam Mains and Nth headings , AND</li> <li>Mine pumping system operating effectively</li> </ul>	<ul style="list-style-type: none"> <li>&gt;38kPa and &lt;40kPa static borehole pressure, OR</li> <li>Notable increase in water accumulation in CVB1 &amp; 2 gate roads, OR</li> <li>Oxygen deficiency or loss of ventilation in CVB gate roads, OR</li> <li>Visible water leakage around borehole standpipe or adjacent strata, OR</li> <li>Failure of borehole valves, OR</li> <li>Water accumulation in Fassi Mains headings, OR</li> <li>Failure of 1 or more pumps at Fassi pit bottom, or loss of power to the Fassi pit bottom pumps resulting in water inflows greater than pumping capability.</li> </ul>	<ul style="list-style-type: none"> <li>Significant water accumulation and/or uncontrolled water make from CVB1 goaf leading to flooding on Fassi Mains, OR</li> <li>Foreseeable extended mine dewatering outage</li> </ul>
<b>ACTIONS</b>	<ol style="list-style-type: none"> <li>Weekly roadway goaf seal inspections and daily pressure gauge reading (static).</li> <li>Daily measurement of water level indicator (pogo stick) in CVB1 gate road</li> <li>Weekly review of UG daily dewatering volumes against averages (Work Order System)</li> </ol>	<ol style="list-style-type: none"> <li>Notify CRO and Undermanager</li> <li>Undermanager to consult Production Manager</li> <li>For oxygen/ loss of ventilation, restrict access to area and take steps to re-establish ventilation in CVB2 in consultation with the ventilation officer</li> <li>Take steps to increase CVB1 water output to drop water level in CVB1 gate road and goaf</li> <li>Consider diverting CVB1 water input</li> <li>Increase inspection frequency in affected area(s)</li> <li>Review requirements for additional pumping equipment or storage areas</li> <li>Where a failure of 1 or more pumps at Fassi pit bottom occurs, or where power to these pumps is lost and water is not controlled, isolate the CVB1 boreholes.</li> </ol>	<ol style="list-style-type: none"> <li>Notify Mine Manager</li> <li>In the event of Significant water accumulation and/or uncontrolled water make from CVB1 goaf leading to flooding on Fassi Mains, consider withdrawal of affected persons to a safe location</li> <li>Initiate the IMT</li> <li>Take the necessary steps to re-establish the mine dewatering system as soon as possible</li> </ol>

LAST REVIEW DATE	NEXTREVIEW DATE	REVISION NO	DOCUMENT OWNER	PAGE 2 of 6
19/10/2021	19/10/2024	9	Technical Services Manager	



# Trigger Action Resp Plan CVC Water Management

## TARP 00089 - CVC Water Management

	Normal	Trigger 1	Trigger 2
<b>1. WALLARAH BOREHOLE PRESSURE AND FLOW</b>	<ul style="list-style-type: none"> <li>Borehole pressures &lt;290Kpa (static reading), AND</li> <li>No increased water make evident at Wallarah seals, AND</li> <li>Walarah Discharge levels consistent with long term trends (&lt;4500 kL daily average)</li> </ul>	<ul style="list-style-type: none"> <li>Borehole pressures 290-310Kpa (static reading), OR</li> <li>Long term average trend from borehole 4500-6000kL/day, OR</li> <li>Walarah Borehole closed for water management or maintenance &gt; 24hr, OR</li> <li>Unplanned reduction of water flow (&lt; 35 l/s)</li> </ul>	<ul style="list-style-type: none"> <li>Borehole pressures &gt;310Kpa (static reading), OR</li> <li>Borehole flow &gt;6000kL daily average during normal operations, OR</li> <li>Increased water make evident at Wallarah seals, OR</li> <li>Failure of Wallarah borehole and/or pipeline</li> </ul>
<b>ACTIONS</b>	<ol style="list-style-type: none"> <li>Real time monitoring of Wallarah borehole flow</li> <li>Walarah borehole pressure (static) to be read weekly as per Work Order</li> <li>Walarah seals inspected weekly</li> <li>Weekly review of UG daily dewatering volumes against averages (Work Order System)</li> <li>Mining operations continue to normal standards</li> </ol>	<ol style="list-style-type: none"> <li>Notify CRO and Undermanager</li> <li>Inspect Wallarah seals for signs of increased water make daily</li> <li>Inspect Wallarah borehole and pump line for signs of leakage</li> <li>Daily pressure reading of Wallarah borehole whilst borehole closed / pressure above 290kpa</li> <li>Ensure both REES pumps at the GTN Dewatering Dam / Weirs are available for operation</li> </ol>	<ol style="list-style-type: none"> <li>If Wallarah borehole fails, then cease production and consider withdrawal of workers to a place of safety</li> <li>Notify Mine Manager</li> <li>As per trigger 1</li> <li>Resume dewatering of Wallarah Borehole, with consideration of GTN Dewater dam levels, GTN water make / storage and production requirements</li> <li>Review need for additional pumping at Wallarah seals to prevent flow to interseam bin</li> <li>Review need for additional pumping capacity at GTN Dewatering Dam / Weirs</li> </ol>

LAST REVIEW DATE	NEXTREVIEW DATE	REVISION NO	DOCUMENT OWNER	PAGE 3 of 6
19/10/2021	19/10/2024	9	Technical Services Manager	



# Trigger Action Resp Plan CVC Water Management

## TARP 00089 - CVC Water Management

	Normal	Trigger 1	Trigger 2
<b>6. Great Northern Seam PIT BOTTOM PUMP / DAM</b>	<ul style="list-style-type: none"> <li>Discharge consistent with long term trend (approx. &lt;1100 kL per day), normal operation of pumps from shaft headings and pit bottom (P/B)</li> </ul>	<ul style="list-style-type: none"> <li>Discharge above long term trend (1100 - 1600kL per day) OR</li> <li>Signs of increased water make in P/B area, dam level rising OR</li> <li>Shaft headings pump off for &gt; 1 week</li> </ul>	<ul style="list-style-type: none"> <li>Discharge (&gt;1600 kL per day) OR</li> <li>Significantly increased water make in P/B area, dam level rising (ie unable to dewater Pit Bottom Dams with current pumping capacity) OR</li> <li>Significantly increased water level in shaft headings</li> </ul>
<b>ACTIONS</b>	<ol style="list-style-type: none"> <li>Real time monitoring of Pit Bottom discharge volumes</li> <li>Daily inspections (stat inspections)</li> <li>Weekly pumping inspection (work order)</li> <li>Weekly review of UG daily dewatering volumes against averages (Work Order)</li> </ol>	<ol style="list-style-type: none"> <li>Notify CRO and Undermanager</li> <li>Undermanager to consult Production Manager</li> <li>Isolate shaft headings pump if necessary to prevent overflowing of P/B dam walls</li> <li>Daily pumping inspections and weekly review of dewatering volumes</li> <li>Restart shaft headings pump as necessary</li> </ol>	<ol style="list-style-type: none"> <li>Notify Undermanager</li> <li>As per trigger level 1</li> <li>Review requirements for additional air pumps in P/B areas</li> <li>Review need for additional capacity to dewater P/B dam (larger or more electric pumps)</li> <li>Consider diversion of Shaft Headings pump delivery directly to GTN Dewater Dams</li> </ol>
<b>7. Great Northern Seam SIPHON LINE/ Sump headings</b>	<ul style="list-style-type: none"> <li>Discharge consistent with Long term trend (&lt;2000 kL per day)</li> </ul>	<ul style="list-style-type: none"> <li>(a) Discharge &lt;600kL/day, or</li> <li>(b) Discharge trend &gt;2000kL/day</li> </ul>	<ul style="list-style-type: none"> <li>Signs of significantly increased water make or failure of existing pumping system to control water make</li> </ul>
<b>ACTIONS</b>	<ol style="list-style-type: none"> <li>Real time monitoring of Siphon line discharge volumes</li> <li>Weekly pumping inspection work order for levels, signs of increased water make</li> <li>Weekly review of UG daily dewatering volumes against averages (Work Order System)</li> </ol>	<p>For (a) Increase inspections of pumps to daily and review requirements for additional pumping in GNS (localised water make)</p> <p>For (b) Inspect for other sources of water make and integrity of Wallarah borehole line</p>	<ol style="list-style-type: none"> <li>Notify Undermanager</li> <li>As per trigger 1</li> <li>Inspect Siphon line for flow / blockages</li> <li>Review requirement for additional pumping infrastructure</li> </ol>

LAST REVIEW DATE	NEXTREVIEW DATE	REVISION NO	DOCUMENT OWNER	PAGE 4 of 6
19/10/2021	19/10/2024	9	Technical Services Manager	



## Trigger Action Resp Plan CVC Water Management

## TARP 00089 - CVC Water Management

	Normal	Trigger 1	Trigger 2
<b>8. GTN MAIN DEWATER DAM LEVEL AND OUTPUT (REES PUMPS)</b>	<ul style="list-style-type: none"> <li>Dam Level &lt;60% (Pump Capacity sufficient to make headway on water make), AND</li> <li>Weekly UG dewatering avg pump consistent with long term averages out &lt;6500 kL day</li> </ul>	<ul style="list-style-type: none"> <li>Dam Level &gt;60% and rising (Insufficient pumping capacity to maintain dewatering rate against water inflow) , OR</li> <li>Dam level &gt; 80%, OR</li> <li>Daily UG dewatering avg &gt;8000 kL/day and dam levels able to be managed with available pumping capacity</li> </ul>	<ul style="list-style-type: none"> <li>Dam Level &gt;90% and rising, OR</li> <li>Daily UG dewatering avg &gt;9500 kL/day and dam level rising, OR</li> <li>Long term UG discharge volume increasing</li> </ul>
<b>ACTIONS</b>	<ol style="list-style-type: none"> <li>Real time dam level and flow monitoring</li> <li>Weekly review of UG daily dewatering volumes against averages (Work Order System)</li> </ol>	<ol style="list-style-type: none"> <li>Notify CRO and Undermanager</li> <li>Undermanager to consult Production Manager</li> <li>Confirm Wallarah Borehole flow and pressure daily</li> <li>If Wallarah Borehole &lt; 300Kpa turn off until dam level lowers &lt;60%</li> <li>Operate 2<sup>nd</sup> REES pump as required</li> </ol>	<ol style="list-style-type: none"> <li>If Wallarah borehole pressures &lt;300kPa turn off until dam level lowers to &lt;60%. Continue monitoring pressure daily.</li> <li>Initiate Incident Management Team (IMT) and review risk of Main dam overflow and impact to Fassi seam drifts/workings. Implement controls as required (including Withdrawal Conditions / Inrush management)</li> <li>Implement action plan for managing GTN Dewater Dams, considering: <ul style="list-style-type: none"> <li>Status / capacity of water make/storage areas at the operation</li> <li>Potential source of additional water make.</li> <li>Weather forecast and status of surface water in relation to discharge capabilities</li> <li>Any requirement for additional pumping capacity</li> <li>Potential emergency discharge increase (surface dams)</li> </ul> </li> <li>Assess potential risks to underground workers. Consider withdrawal to a place of safety.</li> </ol>

LAST REVIEW DATE	NEXTREVIEW DATE	REVISION NO	DOCUMENT OWNER	PAGE 5 of 6
19/10/2021	19/10/2024	9	Technical Services Manager	



# Trigger Action Resp Plan CVC Water Management

## TARP 00089 - CVC Water Management

	Normal	Trigger 1	Trigger 2
<b>9.Surface Water / Dam Discharges</b>	Weekly weather forecast is to be checked daily by the Control Room Operator (CRO) at the commencement of day shift, where greater than 20 mm of rainfall is anticipated at any time, the CRO and Environmental Compliance Coordinator will monitor the forecast and plan appropriately in accordance with Trigger 1 and Trigger 2 below. Rain forecast is to be determined by: <ul style="list-style-type: none"> <li>Review of BOM for Mannering Park (<a href="http://www.bom.gov.au/places/nsw/mannering-park/">http://www.bom.gov.au/places/nsw/mannering-park/</a>)</li> <li>If &gt;20mm rain has been forecast for any 24-hr period, check detailed forecast and determine total potential rainfall (25% chance) by calculating the total rainfall presented in the "25% chance of more than (mm)" for a 24-hour period.</li> <li>Compare total of 25% chance of more to Trigger 1 and Trigger 2 Actions</li> </ul>		
	<ul style="list-style-type: none"> <li>0mm to 25mm rainfall 24 hr forecast</li> </ul>	<ul style="list-style-type: none"> <li>25mm to 40mm rainfall 24 hr forecast/actual</li> </ul>	<ul style="list-style-type: none"> <li>&gt;40mm rainfall 24 hrs forecast/actual</li> </ul>
<b>CHAIN VALLEY COLLIERY ACTIONS</b>	Both REES pumps can run normally <ol style="list-style-type: none"> <li>Automated 10 500 kL limit on pumping system in 24 hrs</li> <li>Real time dam level and flow monitoring</li> <li>Weekly review of UG daily dewatering volumes against averages (WO)</li> <li>Continue to monitor forecast and update Citect accordingly</li> </ol>	Single pump only to run, monitor levels of GTN pit bottom dams (this corresponds to approx. 6.5ML/day at current pump capacity). Implement action plan to manage water make, considering (in order of priority) duration of the rainfall event, and the water storage capacity of the following areas: <ol style="list-style-type: none"> <li>Great North Seam Dams (Siphon)</li> <li>Wallarah Seam</li> <li>Great Northern Sump Headings</li> <li>GNS North East Dams</li> <li>Chain Valley Bay 1</li> </ol>	Notify Mine Manager, Technical Services Manager and Environment Coordinator <ul style="list-style-type: none"> <li>Consider ceasing pumping to surface if no foreseeable elevated risk to mine and personnel safety</li> </ul> Ensure actions are taken as per trigger level 1
<b>MANNERING COLLIERY ACTIONS</b>	Underground pump J135 can run normally	Underground pump J135 can run normally, however, where achievable, ensure underground groundwater storage capacity is maximised in the event of an increase in forecasted rainfall	Consider turning off pump J135 for the period

LAST REVIEW DATE	NEXTREVIEW DATE	REVISION NO	DOCUMENT OWNER	
19/10/2021	19/10/2024	9	Technical Services Manager	PAGE 6 of 6

**Appendix 10: Environmental Incident Categories Matrix**

Category and definition	Immediate action(s)	Follow-up action(s)
<p><b>EI1</b></p> <p><b>Serious environmental issues</b></p> <p>Issues classified EI1 include:</p> <ul style="list-style-type: none"> <li>a breach of an EPL condition, reporting or other compliance condition where clear documentary or other physical evidence of the breach exists and material harm to the environment is caused or threatened;</li> <li>a breach of other environmental regulations where physical evidence exists (e.g. a breach of the POEO Act leading to a Tier 1 or Tier 2 offence prosecution);</li> <li>an incident requiring mandatory reporting to EPA, such as spills or emissions causing or threatening material harm to the health or safety of human beings or to ecosystems; or</li> <li>a pollution incident related to DC’s operations where actual or potential loss or property damage exceeds \$10,000 (including costs to prevent, mitigate or ‘make good’ the associated harm to the environment).</li> </ul>	<p><u>i) Emergency response</u></p> <p>Where necessary, emergency response procedures should be invoked to contain, mitigate or ‘make good’ any associated harm to the environment.</p> <p><u>ii) Notification</u></p> <p>In the event of any pollution incident, the Shift Manager, immediately after becoming aware of the incident, will notify the Environment Compliance Coordinator or Mine Manager. When an environmental incident is deemed by the Environmental Compliance Coordinator to be an EI1 incident:</p> <ul style="list-style-type: none"> <li>it must be reported immediately to the relevant regulatory authorities in accordance with the PIRMP; and</li> <li>the Duty Shift Manager or their delegate must immediately implement the PIRMP and notify any other relevant staff as required.</li> </ul>	<p><u>i) Investigation</u></p> <p>All EI1 incidents are investigated by DC’s Environmental Compliance Coordinator using DC’s Environmental Incident Investigation Procedure.</p> <p><u>ii) Internal reporting:</u></p> <p>A summary report on the incident, subsequent investigations and remedial actions is provided to the Mine Manager as soon as practicable. The Environmental Compliance Coordinator is also responsible for entering the details of the incident into DC’s internal Work Management System (WMS).</p> <p>A summary of the incident is included in monthly reports for DC’s Executive Strategy Committee and in the quarterly Board Environment Report.</p> <p><u>iii) External reporting:</u></p> <p>In addition to immediate notification, all serious environmental issues are reported to EPA as required by the EPL and relevant consent conditions.</p>

Review Date	Next Review Date	Revision No	Document Owner	Page
16/01/2024	16/01/2027	7	Environmental Compliance and Approvals Coordinator	Page 73 of 75

Category and definition	Immediate action(s)	Follow-up action(s)
<p><b>EI2</b></p> <p><b>Significant environmental issues</b></p> <p>Issues classified EI2 include:</p> <ul style="list-style-type: none"> <li>a breach of an EPL condition, reporting or other non-compliance condition requiring reporting to the EPA;</li> <li>a potential breach of an EPL condition or other environmental regulation where there is available physical evidence of a breach and/or pollution control system failure (e.g. significant and/or prolonged events that have caused observable and/or measurable environmental effects or discharges due to a system failure that flows to and is contained within a final holding pond, retention basin or other facility designed as a last line of defence against spills or discharges to the external environment);</li> <li>a minor technical breach of an EPL condition where no environmental harm has occurred but results in a penalty notice or formal warning being issued by EPA; or</li> <li>a failure or overload of an activity's upstream pollution control equipment.</li> </ul>	<p><u>i) Emergency response</u></p> <p>Where necessary, emergency response procedures should be invoked to contain, mitigate or 'make good' any associated harm to the environment.</p> <p><u>ii) Notification</u></p> <p>When a breach of regulation is suspected or in the event of any pollution incident, the <b>Shift Manager</b>, immediately after becoming aware of the incident or breach, will notify the Environmental Compliance Coordinator or Mine Manager. If satisfied that the incident or breach is classified EI2 (i.e. not threatening or causing material environmental harm), the Environmental Compliance Coordinator will notify any other relevant personnel as soon as practicable.</p> <p><u>iii) Adjudication</u></p> <p>Where there is doubt whether an incident is EI1 or EI2, the matter is referred to the Mine Manager for determination. If considered sufficiently serious, the Mine Manager may establish a formal investigation committee.</p>	<p><u>i) Investigation</u></p> <p>The Environmental Compliance Coordinator and a representative from the relevant production group will investigate the cause of the incident and instigate action(s) to prevent recurrence. The investigation will use the Environmental Incident Investigation Procedure.</p> <p><u>ii) Internal reporting:</u></p> <p>A summary report on the incident, subsequent investigations and remedial actions will be prepared by the Environmental Compliance Coordinator and communicated to the Mine Manager.</p> <p>The Environmental Compliance Coordinator is also responsible for entering the details of the incident into DC's internal WMS.</p> <p>Where there has been a technical breach of an EPL condition, a review of the breached condition will be undertaken with recommendations for corrective action or amendment to the EPL.</p> <p>A summary of the incident is included in monthly reports for DC's Executive Strategy Committee and in the quarterly Board Environment Report.</p> <p><u>iii) External reporting:</u></p> <p>Details of all significant environmental issues are reported in accordance with relevant EPL conditions and/or as directed by EPA.</p>
<p><b>EI3</b></p> <p><b>Minor environmental issues</b></p> <p>Issues classified EI3 include:</p> <ul style="list-style-type: none"> <li>a minor technical breach of an EPL or discharges to the environment that are not included in any of the above categories and where it is confirmed no environmental harm has occurred or was threatened; or</li> <li>on-site incidents contained locally at the site of the incident</li> </ul>	<p><u>i) Emergency response</u></p> <p>Where necessary, emergency response procedures should be invoked to contain, mitigate or 'make good' any associated harm to the environment.</p> <p><u>ii) Notification</u></p> <p>All minor environmental issues contained on-site should be reported to the Environmental Compliance Coordinator as soon as practicable. In the event of any</p>	<p><u>i) Investigation</u></p> <p>The Environmental Compliance Coordinator will investigate the cause of the incident and instigate action(s) to prevent recurrence. The investigation will use the Environmental Incident Investigation Procedure.</p> <p><u>ii) Internal reporting:</u></p> <p>The Environmental Compliance Coordinator is also responsible for entering the details of the incident into DC's internal WMS. Details should include any subsequent corrective and</p>

Review Date	Next Review Date	Revision No	Document Owner	Page
16/01/2024	16/01/2027	7	Environmental Compliance and Approvals Coordinator	Page 74 of 75

Category and definition	Immediate action(s)	Follow-up action(s)
in accordance with site procedures and controls.	<p>pollution incident threatening environmental harm, the Shift Manager, immediately after becoming aware of the incident or breach, will notify the Environmental Compliance Coordinator or Mine Manager.</p> <p><u>iii) Adjudication</u></p> <p>Where there is any doubt as to whether the incident EI2 or EI3, the matter is referred to the Mine Manager for determination.</p>	<p>preventative actions.</p> <p>A summary of the incident will be tabled at quarterly EEC meetings.</p> <p><u>iii) External reporting:</u></p> <p>None.</p>

Review Date	Next Review Date	Revision No	Document Owner	Page
16/01/2024	16/01/2027	7	Environmental Compliance and Approvals Coordinator	Page 75 of 75