



**BLACKETT  
MAGUIRE+  
GOLDSMITH**

## **BCA (incl. ACCESS) ASSESSMENT REPORT**

**813 Wallgrove Road  
Eastern Creek**

**Prepared For:  
DHL Supply Chain**

Revision 2

Date: 28 February 2022

Project No.: 210549

Address

Suite 2.01,  
22-36 Mountain St  
Ultimo NSW 2007

Contact

Ph: 02 9211 7777  
Fax: 02 9211 7774



## CONTENTS

1.0	INTRODUCTION	3
1.1	BACKGROUND / PROPOSAL	3
1.2	AIM	3
1.3	PROJECT TEAM	3
1.4	DOCUMENTATION	3
1.5	REGULATORY FRAMEWORK	4
1.6	LIMITATIONS & EXCLUSIONS	4
1.7	TERMINOLOGY	4
2.0	BUILDING CHARACTERISTICS	6
2.1	BUILDING CLASSIFICATION	6
3.0	BCA ASSESSMENT	6
3.1	SECTION B – STRUCTURE	6
3.2	SECTION C – FIRE RESISTANCE	7
3.3	SECTION D – ACCESS & EGRESS	9
3.4	SECTION E – SERVICES AND EQUIPMENT	17
3.5	SECTION F – HEALTH & AMENITY	19
3.6	SECTION J – ENERGY EFFICIENCY	21
4.0	SUMMARY OF KEY COMPLIANCE ISSUES	23
4.1	MATTERS REQUIRING FURTHER RESOLUTION / NON-FIRE SAFETY PERFORMANCE SOLUTIONS	23
4.2	MATTERS TO BE ADDRESSED AS FIRE SAFETY ENGINEERED PERFORMANCE SOLUTIONS	23
5.0	CONCLUSION	24
6.0	APPENDIX 1 – SPEC. C1.1 FRL REQUIREMENTS (TYPE C CONSTRUCTION)	25

REPORT STATUS				
DATE	REVISION	STATUS	AUTHOR	REVIEWED
24.02.2022	0	Preliminary Assessment – Draft Report for Client & Consultant Review	DG	NQ
28.02.2022	1	Updated Assessment	DG	NQ
28.02.2022	2	Updated Assessment	DG	NQ

Prepared by:

Dean Goldsmith  
**Director**  
Blackett Maguire + Goldsmith

Reviewed by:

Nini Quach  
**Assistant Building Surveyor**  
Blackett Maguire + Goldsmith



## 1.0 INTRODUCTION

### 1.1 BACKGROUND / PROPOSAL

Blackett Maguire + Goldsmith Pty Ltd (BM+G) have been commissioned by DHL Supply Chain to undertake a preliminary review of the proposed development, against the deemed-to-satisfy (DTS) provisions of the Building Code of Australia 2019 Amendment 1 (BCA) pursuant to the provisions of Clause 19 of the *Environmental Planning & Assessment (Development Certification & Fire Safety) Regulation 2021* and Clauses 24 & 25 of the *Building and Development Certifiers Regulation 2020*.

The proposed development involves construction of a warehouse building with associated office over two (2) levels, inbound/outbound staging areas, internal ASRS Automated Storage System, dock office, external awning, hardstands. Recessed docks and associated car parking.



Watson Young Architects Drawing No. DA 02, revision A, dated 27<sup>th</sup> January 2022.

### 1.2 AIM

The aim of this report is to:

- Undertake an assessment of the proposed industrial development against the Deemed-to-Satisfy (DtS) Provisions of the BCA 2019 Amendment 1.  
*Note: The version of the BCA that is applicable to building work is the version that is in force at the time the application for the relevant construction certificate of complying development certificate is made. In this regard, it is highlighted that this report includes an assessment of the proposed development against the requirements of BCA 2019 Amendment 1.*
- Identify any BCA compliance issues that require resolution/attention for the proposed development at the CC Application stage.

### 1.3 PROJECT TEAM

The following BM+G Team Members have contributed to this Report:

- Dean Goldsmith (Director)
- Nini Quach (Assistant Building Surveyor)

### 1.4 DOCUMENTATION

The following documentation has been reviewed, referenced and/or relied upon in the preparation of this report:

- BCA 2019 Amendment 1
- Guide to the BCA 2019 Amendment 1.
- Architectural Plans prepared by Watson Young Architects Pty Ltd:



Drawing No.	Rev.	Date	Drawing No.	Rev	Date
DA01	A	27.01.2022	DA02	A	27.01.2022
DA05	A	27.01.2022	DA07	A	27.01.2022
DA08	A	27.01.2022	DA09	A	27.01.2022
DA10	A	27.01.2022	DA11	A	27.01.2022
DA13	A	27.01.2022	DA14	A	27.01.2022
DA15	A	27.01.2022			

## 1.5 REGULATORY FRAMEWORK

Pursuant to Clause 19 of the *Environmental Planning & Assessment (Development Certification & Fire Safety) Regulation 2021* all new building work must comply with the current BCA however the existing features of an existing building need not comply with the BCA unless upgrade is required by other clauses of the legislation.

## 1.6 LIMITATIONS & EXCLUSIONS

The limitations and exclusions of this report are as follows:

- The following assessment is based upon a review of the architectural documentation.
- The provisions of the Disability (Access to Premises – Buildings) Standards 2010 have been assessed as they are generally consistent with the accessibility provisions of the BCA. No assessment has been undertaken with respect to the Disability Discrimination Act (DDA) 1992 as it does not contain any prescriptive design standards. The building owner should be satisfied that their obligations under the DDA have been addressed.
- The Report does not address matters in relation to the following:
  - Local Government Act and Regulations.
  - NSW Public Health Act 1991 and Regulations.
  - Occupational Health and Safety (OH&S) Act and Regulations.
  - Work Cover Authority requirements.
  - Water, drainage, gas, telecommunications and electricity supply authority requirements.
  - DDA 1992.
- BM+G Pty Ltd do not guarantee acceptance of this report by Local Council, FRNSW or other approval authorities.
- No part of this document may be reproduced in any form or by any means without written permission from BM+G Pty Ltd. This report is based solely on client instructions, and therefore, should not be used by any third party without prior knowledge of such instructions.
- This report is intended to cover the key issues associated with the masterplan of the site and as such, separate BCA assessment reports will be required to be undertaken for each building individually.

## 1.7 TERMINOLOGY

- + **Alternative Solution / Performance Solution**  
A Building Solution which complies with the Performance Requirements other than by reason of satisfying the DtS Provisions.
- + **Building Code of Australia (BCA)**  
Document published on behalf of the Australian Building Codes Board. The BCA is a uniform set of technical provisions for the design and construction of buildings and other structures throughout Australia and is adopted in New South Wales (NSW) under the provisions of the EPA Act and Regulation. Building regulatory legislation stipulates that compliance with the BCA Performance Requirements must be attained and hence this reveals BCA's performance-based format.
- + **Construction Certificate**  
Building Approval issued by the Certifying Authority pursuant to Part 6 of the EP&A Act 1979.
- + **Construction Type**  
The construction type is a measure of a buildings ability to resist a fire. The minimum type of fire-resisting construction of a building must be that specified in Table C1.1 and Specification C1.1, except as allowed for—
  - (i) certain Class 2, 3 or 9c buildings in C1.5; and
  - (ii) a Class 4 part of a building located on the top storey in C1.3(b); and
  - (iii) open spectator stands and indoor sports stadiums in C1.7.Note: Type A construction is the most fire-resistant and Type C the least fire-resistant of the types of construction.



- + **Climatic Zone**  
Is an area defined in BCA Figure A1.1 and in Table A1.1 for specific locations, having energy efficiency provisions based on a range of similar climatic characteristics.
- + **Deemed to Satisfy Provisions (DtS)**  
Provisions which are deemed to satisfy the Performance Requirements.
- + **Effective Height**  
The height to the floor of the topmost storey (excluding the topmost storey if it contains only heating, ventilating, lift or other equipment, water tanks or similar service units) from the floor of the lowest storey providing direct egress to a road or open space.
- + **Fire Resistance Level (FRL)**  
The grading periods in minutes for the following criteria-
  - (a) structural adequacy; and
  - (b) integrity; and
  - (c) insulation,and expressed in that order.
- + **Fire Source Feature (FSF)**  
The far boundary of a road which adjoins the allotment; or a side or rear boundary of the allotment; or an external wall of another building on the allotment which is not a Class 10 building.
- + **National Construction Code Series (NCC)**  
The NCC was introduced 01 May 2011 by the Council of Australian Governments. The BCA Volume One (Class 2 to 9 Buildings) is now referenced as the National Construction Code Series Volume One — BCA.
- + **Occupation Certificate**  
Building Occupation Approval issued by the Principal Certifying Authority pursuant to Part 6 of the EPA Act 1979.
- + **Open Space**  
A space on the allotment, or a roof or other part of the building suitably protected from fire, open to the sky and connected directly with a public road.
- + **Performance Requirements of the BCA**  
A Building Solution will comply with the BCA if it satisfies the Performance Requirements. A Performance requirement states the level of performance that a Building Solution must meet. Compliance with the Performance Requirements can only be achieved by-
  - (a) complying with the DtS Provisions; or
  - (b) formulating an Performance Solution which-
    - (i) complies with the Performance Requirements; or
    - (ii) is shown to be at least equivalent to the DtS Provisions; or
  - (c) a combination of (a) and (b).
- + **Sole Occupancy Unit (SOU)**  
A room or other part of a building for occupation by one or joint owner, lessee, tenant, or other occupier to the exclusion of any other owner, lessee, tenant, or other occupier and includes a dwelling.



## 2.0 BUILDING CHARACTERISTICS

### 2.1 BUILDING CLASSIFICATION

The following table presents a summary of relevant building classification items of the proposed Warehouse development:

<b>BCA Class:</b>	Class 5 (Offices, Dock Office and VAS Office), Class 7b (Warehouse)*
<b>Rise in Storeys:</b>	Rise in storeys of Two (2)
<b>Effective Height:</b>	Greater than 12m
<b>Type of Construction:</b>	Type C Construction
<b>Climate Zone:</b>	Zone 6
<b>Maximum Floor Area:</b>	Greater than 18,000m <sup>2</sup> (Large Isolated Building)
<b>Maximum Volume:</b>	Greater than 108,000m <sup>3</sup> (Large Isolated Building)
<b>Structural Importance:</b>	Level 2

## 3.0 BCA ASSESSMENT

### BCA DEEMED-TO-SATISFY COMPLIANCE ISSUES

The following comments have been made in relation to the relevant BCA provisions relating to the compliance issues associated with the proposed industrial development.

### 3.1 SECTION B – STRUCTURE

#### PART B1 – STRUCTURAL PROVISIONS

**+ Clause B1.2/B1.4 – Determination of Individual Actions / Determination of Structural Resistance of Materials and Forms of Construction**

Structural engineering details prepared by an appropriately qualified structural engineer to be provided to demonstrate compliance with Part B1. This will include the following Australian Standards (where relevant):

- AS 1170.0 – 2002 General Principles
- AS 1170.1 – 2002, including certification for balustrades (dead and live loads)
- AS 1170.2 – 2011, Wind loads
- AS 1170.4 – 2007, Earthquake loads
- AS 3700 – 2018, Masonry Structures
- AS 3600 – 2018, Concrete Structures
- AS 4100 – 1998, Steel Structures and/or
- AS 4600 – 2018, Cold formed steel Structures.
- AS 2159 – 2009, Piling Design & Installation
- AS 1720 – 2010, Design of Timber Structure
- AS/NZS 1664.1 & 2 – 1997, Aluminium Structures
- AS 2047 – 2014, Windows and External Glazed Doors in buildings.
- AS 1288 – 2006, Glass in buildings.
- AS 3660.1 – 2014, Termite control (or confirmation no primary building elements are timber).

*Comments: Structural design details and certification will be required at CC application stage.*

*Note: Design certification will also be required from the Architect and Services Consultants to confirm compliance with Section 8 of AS1170.4-2007 with regard to the design of non-structural parts and components and their fastenings for horizontal and vertical earthquake forces and inter-storey drift.*



## 3.2 SECTION C – FIRE RESISTANCE

### FIRE RESISTANCE AND STABILITY

#### + Clause C1.1 – Type of Construction Required

The minimum type of fire-resisting construction of a building must be that specified in Table C1.1 and Specification C1.1 except as allowed for in this clause.

*Comments: Type C Construction applies to the proposed Warehouse building as it has a rise in storeys of not more than two (2) – see notes under Spec. C1.1 below.*

#### + Clause C1.2 – Calculation of Rise in Storeys

The rise in storeys of a building is the sum of the greatest number of storeys at any part of the external walls of the building and any storeys within the roof space calculated in accordance with the requirements set out in this clause.

*Comments: The proposed building has a rise in storeys of two (2).*

#### + Clause C1.10 – Fire Hazard Properties

The fire hazard properties of the linings, materials and assemblies in a Class 2 to 9 building must comply with **Specification C1.10** and the additional requirements of the **NSW Provisions** of the Code.

*Comments: Design certification required at CC application stage and installation certification (including relevant test reports confirming the critical radiant flux of floor linings and group number of wall and ceiling linings) required at OC stage.*

### COMPARTMENTATION AND SEPARATION

#### + Clause C2.2 – General Floor Area and Volume Limitations

Sets out the parameters for the area and volume of Class 5, 6, 7, 8 & 9 buildings as required by sub-clauses (a), (b) & (c).

*Comments: The proposed Warehouse building is a Class 5 & 7b Large Isolated Building of Type C Construction and as such the provisions for maximum fire compartment size under Table C2.2 do not apply.*

*Refer to comments under C2.3 & C2.4 below in relation to the Large Isolated Building provisions applicable to the proposed development.*

#### + Clause C2.3 – Large Isolated Buildings

A Large Isolated Building that contains Class 5, 6, 7, 8 or 9 parts, is required to be—  
(i) protected throughout with a sprinkler system complying with Specification E1.5; and  
(ii) provided with a perimeter vehicular access complying with C2.4(b).

*Comments: The proposed Warehouse building is required to be sprinkler protected throughout and provided with perimeter vehicular access in accordance with Clause C2.4 (see notes below) pursuant to their Large Isolated Building designation under this clause.*

#### + Clause C2.4 – Requirements for Open Spaces & Vehicular Access

An open space and vehicular access required by C2.3 must comply with the requirements of sub-clauses (a) & (b) of this Part as that they must be 6m wide within 18m of the building and of a suitable bearing capacity and unobstructed height to permit the operation and passage of FRNSW vehicles.

*Comments: The proposed Warehouse building does not comply with the provisions of C2.4 and thus the following non-compliance issue is required to be addressed as a Performance Solution by the Fire Engineer to demonstrate compliance with Performance Requirement CP9:*

- + *Perimeter Vehicular Access (PVA) is greater than 18m from the external walls along the southern side of the building off the proposed Estate Road – see Figure 1 over page.*
- + *PVA on the eastern side of the building is open, however it passes under the structural steel frame of the x2 super awning structures that are located over the loading areas on this side of the building, which is not strictly compliant with C2.4(b)(iv).*

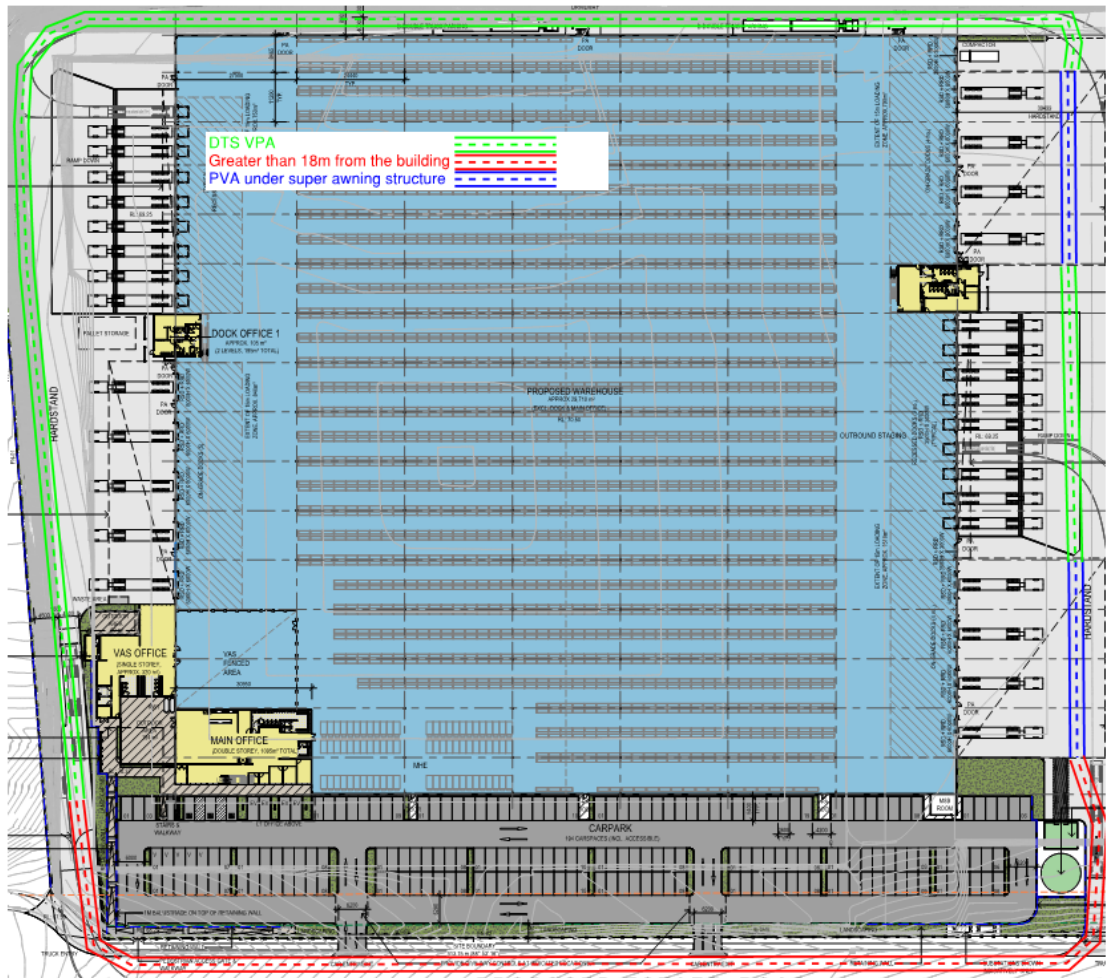

Figure 1 – Perimeter Vehicular Access per BCA C2.4.

Note 1: Any proposed sliding gates are to achieve no less than 6m unobstructed width or the reduced width will need to be included in the above Performance Solution.

Note 2: The driveways providing vehicular perimeter access must be designed with adequate loading capacities to withstand a fire truck and the gradients of any ramps and swept paths should take into consideration the requirements of the FRNSW Fire Safety Guideline – Access for Fire Brigade Vehicles and Firefighters.

**+ Clause C2.8 – Separation of Classifications in the Same Storey**

If a building has parts of different classifications located alongside one another in the same storey, each element must have the required higher FRL for the classifications concerned.

Alternatively, the parts must be separated by a fire wall having the higher FRL for the classifications prescribed in Table 3 or 4 of BCA Specification C1.1 (for Type A or Type B Construction), or Table 5 for Type C Construction.

*Comments:* The provisions of C2.8(a) could be applied to the Warehouse and Office parts on Ground Floor as the different classifications have the same FRL requirements under Table 5 of Spec. C1.1.

**+ Clause C2.12 – Separation of Equipment**

Equipment as listed below must be separated from the remainder of the building with construction complying with (d), if that equipment comprises –

- (i) Lift motors and lift control panels; or
- (ii) Emergency generators used to sustain emergency equipment operating in the emergency mode; or
- (iii) Central smoke control plant; or
- (iv) Boilers; or



- (v) A battery system installed in the building that has a voltage of 12 volts or more and a storage capacity of 200kWh or more.

**Note:** Separating construction must have –

- (A) an FRL as required by Specification C1.1, but not less than 120/120/120; and
- (B) any doorway protected with a self-closing fire door having an FRL of not less than -/120/30.

Comments: Where appropriate, details demonstrating compliance are to be included in the CC Application plans.

#### + **Clause C2.13 – Electricity Supply System**

(a) An electricity substation, main switchboard which sustains emergency equipment operating in the emergency mode, located within a building must –

- (i) Be separated from any other part of the building by construction having an FRL of not less than 120/120/120; and
- (ii) Having any doorway in that construction protected with a self-closing fire door having an FRL of not less than -/120/30
- (i) Be separated from any other part of the building by construction having an FRL of not less than -/120/30.
- (ii) Have any doorway in that construction protected with a self-closing fire door having an FRL of not less than -/120/30.

(b) Electrical conductors located within a building that supply

**Note:** Where emergency equipment is required in a building, all switchboards in the electrical installation, which sustain the electricity supply to the emergency equipment switchgear is separated from the non-emergency equipment switchgear by metal partitions designed to minimise the spread of fault from the non-emergency equipment switchgear.

Comments: Where appropriate, details demonstrating compliance are to be included in the CC Application plans.

### PROTECTION OF OPENINGS

#### + **Clause C3.15 – Openings for Services Installations**

All opening for services installations in building elements required to be fire-resisting with respect to integrity and insulation must be protected in accordance with the provisions of Spec. C3.15.

Comments: Note – see C2.12 & C2.13.

### SPECIFICATIONS

#### + **Specification C1.1 – Fire Resisting Construction**

The new building works are required to comply with the requirements detailed under Table 5 of Specification C1.1 for Type C Construction.

Comments: Note.

#### + **Specification C1.10 – Fire Hazard Properties.**

This Specification sets out requirements in relation to the fire hazard properties of linings, materials and assemblies in Class 2 to 9 buildings as set out in the Tables.

Comments: Refer to comments under Clause C1.10 above – certification will be required at both CC and OC Application stages.

#### + **Specification C1.11 – Performance of External Walls in Fire**

This specification contains measures to minimise in the event of fire the likelihood of external walls collapsing outwards as complete panels and the likelihood of panels separating from supporting members.

Comments: Structural design certification and details demonstrating compliance are required to be provided at CC Application stage.

### 3.3 SECTION D – ACCESS & EGRESS

#### PROVISION FOR ESCAPE

##### + **Clause D1.3 – When Fire Isolated Stairways & Ramps are Required**



This clause specifies the requirements for when fire isolated stairs or ramps are required in buildings based upon the number of storeys that they interconnect and the classification of the building.

*Comments: The exit stairs serving the Level 1 Offices within the building will not connect more than 3 storeys in a sprinkler protected building and as such are not required to be fire isolated in accordance with D1.3(b).*



#### + **Clause D1.4 – Exit Travel Distances**

This clause specifies the permitted travel distances allowable from Class 2 to Class 9 buildings. Sub-clauses (a) to (f) specify the maximum distances to be taken into account for the various uses in each Class of building.

*Comments: The exit travel distances are non-compliant within the proposed building. In this regard, the following non-compliance issues will be required to be addressed as a Performance Solution by the Fire Safety Engineer to demonstrate compliance with Performance Requirements DP4 & EP2.2:*

- Up to 100m to the nearest exit from the central Warehouse areas.

#### + **Clause D1.5 – Distances Between Alternative Exits**

Exits required as alternative exits must be –

- not less than 9m apart; and
- not more than – 60m apart.
- Located so that the alternative paths of travel do not converge such that they become less than 6m apart.

*Comments: The distance between alternative exits are non-compliant within the following areas of the building. In this regard, the following non-compliance issue will be required to be addressed as a Performance Solution by the Fire Safety Engineer to demonstrate compliance with Performance Requirements DP4 & EP2.2:*

- Up to 205m between alternative exits within the Warehouse areas.

#### + **Clause D1.6 – Dimensions of Exits**

This clause details the minimum dimensions such as height and width of paths of travel from Class 2 to 9 buildings. It also specifies the minimum dimensions of doorways from the various compartments and the width of exit doors from buildings depending on the uses and functions carried out within them.

*Comments: Population numbers for the buildings are detailed under D1.13 below and based on these numbers compliance with D1.6 is readily achievable. Final details showing compliant dimensions of all exits (including minimum 1m wide clearances and min. clear height of 2.1m) from the buildings are to be confirmed on the CC Application plans.*

#### + **Clause D1.9 – Travel by Non-fire-isolated Stairways or Ramps**

Sub-clauses (a) to (f) set out the prescribed travel distances to be provided in required exits of Class 2 to 9 buildings and Class 4 parts of buildings. The sub-clauses set out the maximum distances to be taken into account for the various uses in each Class of building.

*Comments: The total distance to open space from the Level 1 Office areas and the distance to open space from the discharge of the stair on Ground Floor complies with this Clause.*

#### + **Clause D1.10 – Discharge from Exits**

Requires that an exit must not be blocked at the point of discharge. Barriers such as bollards must be installed to prevent vehicles from blocking the discharge from exits.

This clause also provides the methods of construction, location and separation, at exit discharge points for all building Classes.

*Comments: All exit discharge points from the building are required to be protected in accordance with the requirements of this clause.*

#### + **Clause D1.13 – Number of Persons Accommodated**

Clause D1.13 and Table D1.13 are used to calculate the anticipated number of people in particular types of buildings so that minimum exit widths and the required number of sanitary and other facilities can be calculated. This clause and table are not to be used for non-BCA purposes.

*Comments: The following population numbers have been calculated in accordance with Table D1.13 based on 10m<sup>2</sup> per person in the office areas; and 30m<sup>2</sup> per person for the warehouse with 50% of the warehouse being allocated to circulation space and racking structures:*

- Warehouse: 495 persons
- Main Office: 110 persons
- Dock Offices: 58 persons



- VAS Office: 32 persons

The above population numbers may be considered excessive for the proposed buildings and as such, alternative population numbers may be provided by DHL at CC application stage in accordance to confirm compliance with D1.6 and F2.3.

## CONSTRUCTION OF EXITS

### + Clause D2.7 – Installations in Exits & Paths of Travel

This clause restricts the installation of certain services in fire-isolated exits, non-fire-isolated exits and certain paths of travel to exits. Sub-clauses (a) to (e) prescribes which services **shall not be installed** as well as the circumstances in which certain services **may be installed** in fire-isolated and non-fire-isolated exits.

*Comments: This requirement applies to all cupboards containing electrical distribution boards or comms. equipment that are located in a path of travel to an exit. In this regard, such cupboards are to be enclosed in non-combustible materials and are to be suitably sealed against the spread of smoke.*

### + Clause D2.8 – Enclosure of Space under Stairs and Ramps

The space below a required fire-isolated stairway or ramp in a fire-isolated shaft must not be enclosed to form a cupboard or other enclosed space. If the required stairway or ramp is non-fire-isolated, (including an external stairway) any cupboard underneath must have an FRL of 60/60/60, with a self-closing -60/30 door.

*Comments: Any enclosures under the stairs will need to achieve an FRL of -/60/60 and the doorways will need to be fitted with self-closing -/60/30 fire doors (where applicable).*

### + Clause D2.13 – Goings & Risers

This clause sets out the detailed requirements for the construction and geometry of the goings and risers in required stairways. These details are set out in sub-clauses (a) to (c) and Table D2.13 Riser and Going Dimensions.

*Comments: All stairs are to have dimensions that comply with Table D.13 (below), have solid risers, and are to have contrasting nosings and slip resistant surfaces throughout in accordance with Clause 11 of AS1428.1-2009. (See diagram in Part D3 below).*

*Note: Refer to the slip resistance requirements for stairs below under Clause D2.14. On site slip testing will be required at OC Application stage.*

Riser and Going Dimensions (mm)			
	Riser (R)	Going (G)	Quantity (2R + G)
Maximum	190	355	700
Minimum	115	250	550

### + Clause D2.14 – Landings

The dimensions and gradients of landings in stairways are set out in this clause; the configuration will depend on the proposed use of a building.

Landing surfaces must be slip resistant OR have slip resistant nosings not less than that listed in Table D2.14 when tested in accordance with AS4586.

*Comments: Architect to note. On-site slip testing will be required at OC Application stage.*

Application	Surface conditions	
	Dry	Wet
Ramp steeper than 1:14	P4 or R11	P5 or R12
Ramp steeper than 1:20 but not steeper than 1:14	P3 or R10	P4 or R11
Tread or landing surface	P3 or R10	P4 or R11

### + Clause D2.15 – Thresholds

The threshold of a doorway must not incorporate a step or ramp at any point closer to the doorway than the width of the door leaf unless –



In a building required to be accessible by Part D3, the doorway –

- (i) Opens to a road or open space; and
- (ii) Is provided with a threshold ramp or step ramp in accordance with AS1428.1;

In other cases –

- (i) Opens to a road or open space, external stair landing or external balcony; and
- (ii) The door sill is not more than 190mm above the finished surface of the ground, balcony, or the like, to which the doorway opens.

Comments: Architect to note. Details demonstrating compliance will be required to be included in the CC plans.

#### + **Clause D2.16 – Balustrades or Other Barriers**

This clause details where balustrades are required to be provided and sets out in specific detail the construction requirements. Typically, the following will apply to this class of building:

- Balustrades are required where the fall to the level below is 1m or more in height. The minimum height of a balustrade is 1m above the floor of the landing, walkway or the like; and 865mm above the floor of a stairway or a ramp.
- For a fall of more than 4m to the surface level below, a window sill must be a minimum of 865mm in height above the height of the floor surface.
- Where the floor is more than 4m above the surface beneath the balustrade any horizontal or near horizontal members between 150mm and 760mm above the floor must not facilitate climbing.
- Balustrades must be constructed so as to not permit a sphere of 125mm diameter to pass through. The exception to this is within fire isolated exits within the building, or internal stairs within a Class 7b or 8 building, where the rails can be positioned a maximum of 460mm apart, so long as a bottom rail is located so a sphere of 150mm cannot pass through the opening between the nosing of the stair treads and the rail or between the floor of the landing, balcony or the like. External stairs associated with a Class 7b or 8 building are required to have gaps no greater than 125mm.

Comments: Architect to note. Details demonstrating compliance are to be submitted with the CC Application drawings for assessment against the above criteria.

#### + **Clause D2.17 – Handrails**

This Clause sets out the requirements regarding the location, spacing and extent of handrails required to be installed in buildings.

Comments: Architect to note. Details demonstrating compliance will be required to be included in the CC plans. Handrails serving all stairs and ramps both internally and externally are required to comply with the accessibility requirements of Clause D3.3 and AS 1428.1-2009.

#### + **Clause D2.19 – Doorways and Doors**

This clause applies to all doorways and refers to the types of doors that cannot be used in buildings of prescribed uses, the use of power operated doors and the force required to operate sliding doors.

If the door is also power operated, it must be opened manually under a force of not more than 110N if there is a malfunction or failure to the power source; and open on the activation of a fire or smoke alarm anywhere in the fire compartment served by the door.

Comment: Architect to note. Details demonstrating compliance will be required to be included in the CC plans.

#### + **Clause D2.20 – Swinging Doors**

A swinging door in a required exit or forming part of a required exit must be installed to the requirements of sub-clauses (a), (b) & (c). This clause only applies to swinging doors in doorways serving a required exit or forming part of a required exit. It does not apply to other doorways – see notes in the Guide to the BCA.

Comments: All proposed egress doors are required to swing in the direction of egress in accordance with D2.20(a). Compliance is generally achieved with the exception of the entry door to the VAS office which is required to swing outwards in the direction of egress.

#### + **Clause D2.21 – Operation of Latch**

A door in a required exit or forming part of a required exit and in a path of travel to a required exit must be readily openable without a key from the side that faces a person seeking egress, by a single downward action or pushing action on a single device which is located between 900mm & 1.1m from the floor. This



clause prohibits the use of devices such as deadlocks and knobs where knobs must be operated in a twisting motion in accordance with sub-clauses (a) & (b). D2.21 also sets out exceptions in relation to buildings where special security arrangements are required in relation to the uses carried out.

*Comments: Architect to note. Details demonstrating compliance will be required to be included in the CC plans.*

## ACCESS FOR PEOPLE WITH A DISABILITY (INCLUDING DDA ACCESS TO PREMISES – BUILDING STANDARDS)

### + **Clause D3.2 – General Building Access Requirements for People with Disabilities**

Access must be provided to and within all areas normally used by occupants (as required by Clause D3.1) within the buildings from the main points of pedestrian entry at the allotment boundary; from another accessible building connected by a pedestrian link; and any accessible car parking space.

Access must be provided through the principal pedestrian entrance and through not less than 50% of all pedestrian entrances (including the principal pedestrian entry). In addition, as the buildings are greater than 500m<sup>2</sup>, the non-accessible entrance must not be greater than 50m from an accessible entrance.

*Comments: Compliant access is required from the allotment boundary and from accessible parking spaces to a compliant main entry of the building in accordance with AS 1428.1-2009. Refer to additional comments under D3.3 and D3.4 below. Compliance with D3.2 requirements is readily achievable.*

### + **Clause D3.3 – Parts of the Building to be Accessible**

This part specifies the requirements for accessways within buildings which must be accessible. In accordance with Clause D3.3; ramps & stairways must comply with Clause 10 & 11 of AS 1428.1-2009 (respectively), whilst fire isolated stairs must comply with Clauses 11.1(f) & (g) of AS 1428.1-2009 only. In addition, any storey with a floor area more than 200m<sup>2</sup> must be served by a passenger lift that is designed to comply with Clause E3.6, and all accessways must include passing & turning spaces per AS 1428.1-2009.

*Comments: As indicated above, the proposed Warehouse building is required to be accessible throughout in accordance with AS1428.1-2009. It is noted that subject to D3.4 below, compliance with the requirements of D3.3 and AS 1428.1-2009 is readily achievable; however, details and design certification will be required to be provided at CC Application stage.*

*The following is a summary of some of the key matters which need to be considered from Clause D3.3 and AS 1428.1-2009:*

- *An accessway complying with AS1428.1-2009 is required from the allotment boundary and on-site accessible carparking to the main entry of the proposed Warehouse building. Design details demonstrating compliance are required at CC Application stage.*
- *Every ramp, except a fire-isolated ramp, must comply with clause 10 in AS1428.1-2009.*
- *Every stairway, except a fire-isolated stairway, must comply with clause 11 of AS1428.1-2009.*
- *Every passenger lift must comply with clause E3.6. It is understood that the Dock Offices will be subject to a D3.4 concession and as such will not require a lift access to the first floor – See notes below under D3.4 – DHL to confirm.*
- *Accessways must have passing spaces complying with AS1428.1-2009 at a maximum 20m intervals on those parts of the accessway where a direct line of sight is not available and turning spaces complying with AS1428.1-2009 within 2m of the end of accessways and at a maximum 20m intervals along the accessway.*
- *Clause D3.3(g) and (h) requires that the pile height or pile thickness shall not exceed 11mm and the carpet backing thickness shall not exceed 4mm. Moreover, the carpet pile height or pile thickness dimension shall not exceed 11mm, the carpet backing thickness dimension shall not exceed 4mm and their combined dimension shall not exceed 15mm.*
- *The minimum width of an accessible doorway must have a clear opening width of not less than 850mm in accordance with AS1428.1. An accessway must have a minimum clear width of 1000mm and 2000mm clear height.*
- *All doorways on a continuous path of travel shall have a minimum luminance contrast of 30% provided between: door leaf and door jamb; or door leaf and adjacent wall; or architrave and wall; or door leaf and architrave; or door jamb and adjacent wall. The minimum width of the area of luminance contrast shall be 50mm.*



- Circulation space to the new doorways that are required to be accessible are to comply with Section 13 of AS 1428.1-2009.

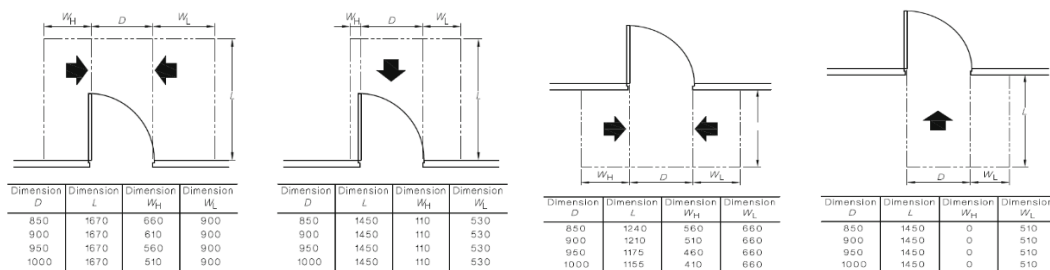

- Turning Spaces and Passing Spaces in all areas are required to be provided on each level of the building in accordance with Clauses 6.4 & 6.5 of AS 1428.1-2009.

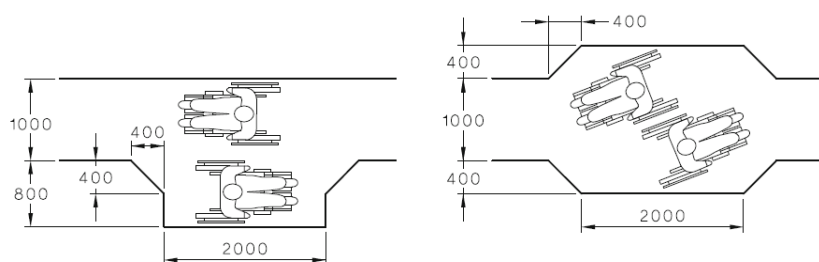

### Stairways

- Every common area stairway must be constructed in accordance with Clause 11 of AS1428.1, except if they are within a fire isolated exit (which need to comply with Clause 11.1f & g only) or serve the areas in the building that a D3.4 Exemption has been applied to. Details will need to be confirmed on the plans for CC.

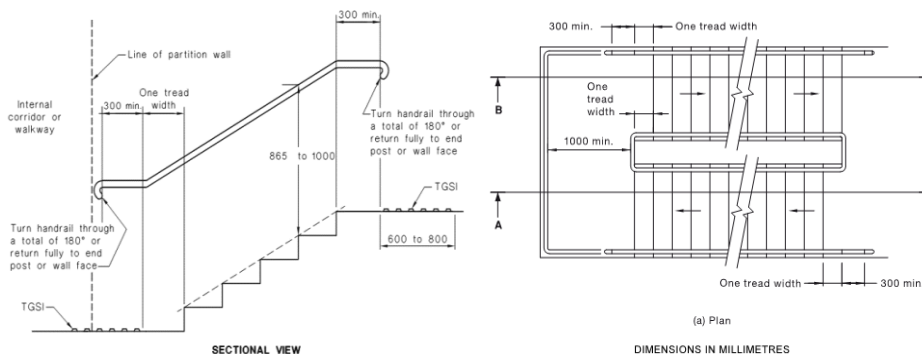

- Stairs shall have opaque risers (i.e. solid)
- Stair nosing's shall comply with the following diagram, which achieve a luminance contrast of 30% to the background (tread):

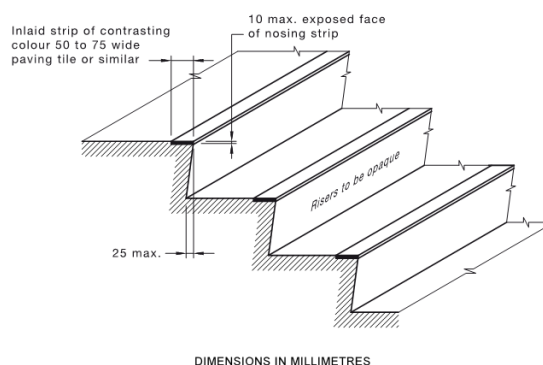



## Handrails

- *Handrails shall be installed along stairways as follows:*
  - *Shall be continuous through the flight and where practicable, around landings and have no obstruction on or above up to a height of 600mm,*
  - *Installed along both sides of the stairway (giving consideration also to 1m unobstructed width),*
  - *Shall have a compliant hand clearance in accordance with Figure 29 of AS 1428.1-2009.*

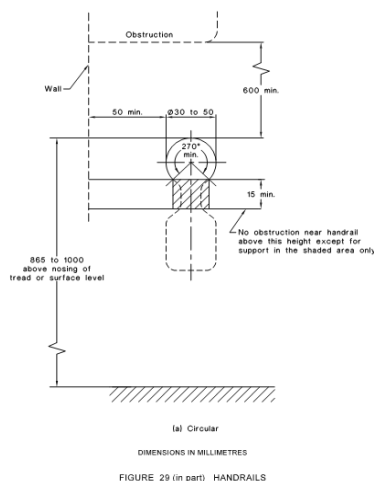

### + **Clause D3.4 – Exemptions**

This clause provides details on buildings or parts of buildings not required to be accessible under the BCA where providing access would be inappropriate because of the nature of the area/use or the tasks undertaken.

*Comment: It is recommended that advice be obtained from an accredited Access Consultant at the CC Application stage, however, consideration to an exemption for the Warehouse, Dock Offices, gatehouses & Hardstand areas may be appropriate on this project. Confirmation from DHL will be required that includes request for concession, where this would be applied and the reasons why it would be inappropriate for access for people with disabilities within the facility.*

### + **Clause D3.5 – Accessible Parking**

This clause provides details of the number of accessible carparking spaces required in a carpark depending on the classification of the building.

*Comments: Compliant Accessible Parking spaces are to be provided at a rate of 1 per 100 spaces for the Warehouse / Office areas. The current plans comply with the requirements of this clause.*

### + **Clause D3.6 Signage**

Braille and tactile signage must be provided to required accessible sanitary facilities, spaces with hearing augmentation, ambulant sanitary facilities, pedestrian entrances that are not accessible, **and** to each door required by Clause E4.5 to be provided with an exit sign. The latter is to state EXIT and state the level eg. LEVEL 1.

*Comments: Architect to note.*

### + **Clause D3.8 – Tactile Indicators**

This clause provides for the installation of tactile indicators in buildings required to be accessible and must be provided to warn people who are blind or have a vision impairment that they are approaching a stairway, escalator, passenger conveyor, ramp, overhead obstruction or an accessway meeting a vehicular way, except for areas exempted by D3.4.

*Comments: Subject to D3.4 above, stairways and ramps serving the building, any overhead projections less than 2m in height and any paths leading directly to a driveway or roadway without a kerb will need to be provided with Tactile Ground Surface Indicators in accordance with AS1428.4.*



**+ Clause D3.11 – Ramps**

Ramps may be used as part of an accessway where there is a change of level and must comply with the requirements set out in AS1428.1.

*Comments: Architect to note. Details demonstrating compliance will be required to be included in the CC plans.*

**+ Clause D3.12 – Glazing on an Accessway**

This part requires the provision of a contrasting strip, chair rail, handrail or transom across all frameless or fully glazed doorways and surrounding glazing capable of being mistaken for an opening.

*Comments: Glazing capable of being mistaken for an opening as listed above must be clearly marked for its full width with a solid and non-transparent contrasting line being not less than 75mm wide and the lower edge must be located between 900mm and 1000mm above the plane of the finished floor level.*

### 3.4 SECTION E – SERVICES AND EQUIPMENT

---

#### FIRE FIGHTING EQUIPMENT

**+ Clause E1.3 – Fire Hydrants**

E1.3(a) – A fire hydrant system must be provided to serve a building having a total floor area greater than 500m<sup>2</sup> and where a fire brigade is available to attend a building fire.

E1.3(b) – Requires that the fire hydrant system must be installed in accordance with the provisions of AS2419.1 and also details where internal hydrants must be located.

*Comments: The proposed Warehouse building is required to be served by a compliant hydrant system incorporating ring a main. Details demonstrating compliance with the provisions of E1.3 and AS 2419.1-2005 are required to be provided at CC Application stage.*

*Hydrant booster assemblies are required to be accessible to the brigade, located within sight of the main entry of the building, at least 10m from any proposed substation, and adjacent to the main vehicular and pedestrian entry into the site. Where the location of hydrant boosters departs from the above provisions, it will need to be addressed as a Fire Engineered Performance Solution to demonstrate compliance with Performance Requirement EP1.3.*

*Additionally, where hydrants that are located outside the building but are not open to the sky (e.g., located under an awning or the like) are proposed to be treated as external hydrants, and/or where external hydrants are not proposed to be provided with a radiant heat shield, a Performance Solution from the Fire Engineer will be required demonstrating compliance with Performance Requirement EP1.3.*

**+ Clause E1.4 – Fire hose reels**

A fire hose reel system must be provided to serve a building where one or more internal fire hydrants are installed or in a building with a floor area greater than 500m<sup>2</sup>.

This clause requires that the fire hose reel system must be installed in accordance with AS 2441 and sets out the detail for location and uses of fire hose reels.

*Comments: The proposed Warehouse portions of the building are required to be served by a compliant fire hose reel system; however, the Office areas do not require coverage as they are subject to the Class 5 concession. Details demonstrating compliance are to be provided at the CC application stage.*

**+ Clause E1.5 – Sprinklers**

A sprinkler system must be installed in a building or part of a building when required by Table E1.5 and comply with Specification E1.5. Table E1.5 sets out which types of building occupancies and Classes which are required to have sprinkler systems installed in them.

Specification E1.5 sets out requirements for the design and installation of sprinkler systems.

*Comments: The proposed Large Isolated Building is required to be sprinkler protected throughout in order to address the requirements of Clause C2.3 and Table E1.5. Details demonstrating compliance are to be provided at the CC application stage.*

*In accordance with Clause 4.14.1 of AS2118.1-2017, sprinkler boosters are required to comply with the requirements of AS2419.1-2005 for a hydrant booster, which will need to be addressed as a Performance Solution from the Fire Engineer to demonstrate compliance with EP1.4.*



**+ Clause E1.6 – Portable fire extinguishers**

Portable fire extinguishers must be provided as listed in Table E1.6 and must be selected, located and distributed in accordance with Sections 1, 2, 3 and 4 of AS 2444.

*Comments: Fire extinguishers will be required to be installed in the proposed buildings in accordance with Table E1.6 and AS 2444-2001 including the Class 5 Office areas.*

**+ Clause E1.8 – Fire Control Centres**

A fire control centre facility in accordance with Specification E1.8 must be provided for a building having an effective height of more than 25m and in a Class 6, 7, 8 or 9 building with a total floor area of more than 18,000m<sup>2</sup>. Specification E1.8 describes the construction and content of required for both fire control centres and rooms.

*Comments: As the floor area of the proposed Warehouse buildings exceeds 18,000m<sup>2</sup>, it is required to be provided with a Fire Control Centre facility that complies with Clauses 2-5 of Spec. E1.8.*

## SMOKE HAZARD MANEGEMENT

**+ Clause E2.2 – General Requirements**

Class 2 to 9 buildings must comply with the provisions of this Clause to remove smoke during a fire, to control the operation of air handling systems and to prevent the spread of smoke between compartments.

Buildings must comply with the provisions of **Table E2.2a**, as applicable to Class 2 to 9 buildings. It deals with the design and construction of air handling systems that are part of a smoke hazard management system and air handling systems that are not part of a smoke hazard management system.

The details relating to the installation and operation of the systems are set out in **Specifications E2.2a, E2.2b and E2.2c**.

*Comments: As the floor area and volume of the proposed Warehouse building is greater than 18,000m<sup>2</sup> and 108,000m<sup>3</sup> respectively, an automatic smoke exhaust system is required to be provided. Consideration may be given to a Performance Solution from the Fire Engineer to rationalise the smoke hazard exhaust requirements of Spec. E2.2b and demonstrate compliance with Performance Requirement EP2.2.*

## LIFT INSTALLATIONS

**+ Clause E3.3 – Warning Against use of Lifts in Fire**

Warning signs required be provided must be displayed where they can be readily seen and must comply with the details and dimensions of **Figure 3.3**.

*Comments: Architect and Lift Contractor to note.*

**+ Clause E3.5 – Landings**

Access and egress to and from lift well landings must comply with the Deemed-to-Satisfy Provisions of Part D, including the accessibility requirements of AS 1428.1-2009.

*Comments: Architect and Lift Contractor to note.*

**+ Clause E3.6 – Passenger Lifts**

In an accessible building, every passenger lift must be one of the types identified in **Table E3.6a**, have accessible features in accordance with **Table E3.6b** and not rely on a constant pressure device for its operation if the lift car is fully enclosed.

*Comments: Lift Contractor to note. Lift floor dimensions must be not less than 1100mm wide x 1400mm deep per Table E3.6b.*

## VISABILITY IN AN EMRGENCY, EXIT SIGNS AND WARNING SYSTEMS

**+ Clause E4.2 – Emergency Lighting Requirements**

This clause details when emergency lighting must be installed in Class 2 to 9 buildings. The requirements for buildings and parts of buildings are detailed in sub-clauses (a) to (i) and each sub-clause must be considered as more than one may apply to any single building.

*Comments: Emergency Lighting is required throughout the proposed Warehouse building in accordance with E4.2, E4.4 and AS/NZS 2293.1-2018.*



**+ Clause E4.4 – Design & Operation of Emergency Lighting**

Every required emergency lighting system must comply with AS2293.1.

*Comments: Electrical Consultant to note.*

**+ Clause E4.5 – Exit Signs**

An exit sign must be clearly visible to persons approaching the exit and must be installed on, above or adjacent to each door providing egress from a building. Sub-clauses (a) to (d) set out the situations where exit signs are required to be installed.

*Comments: Electrical Consultant to note. Details demonstrating compliance will be required to be included in the CC plans.*

**+ Clause E4.6 – Direction Signs**

If an exit is not readily apparent to persons occupying or visiting the building then exit signs must be installed in appropriate positions in corridors, hallways, lobbies, and the like, indicating the direction to a required exit.

*Comments: Electrical Consultant to note. Details demonstrating compliance will be required to be included in the CC plans.*

**+ Clause E4.8 – Design & Operation of Exit Signs**

Every required exit sign must comply with AS/NZS 2293.1 and be clearly visible at all times when the building is occupied by any person having the legal right of entry into the building.

*Comments: Electrical Consultant to note. Details demonstrating compliance will be required to be included in the CC plans.*

### 3.5 SECTION F – HEALTH & AMENITY

---

#### DAMP AND WEATHERPROOFING

**+ Performance Requirement FP1.4**

A roof and external wall (including openings around windows and doors) must prevent the penetration of water that could cause

- a) Unhealthy or dangerous conditions, or loss of amenity for occupants; and
- b) Undue dampness or deterioration of building elements.

*Note 1: There are no Deemed-to-Satisfy provisions for this Performance Requirement in respect to External Walls.*

*Note 2: Refer to Clause F1.5 for roof coverings.*

*Comments: A documented Performance Solution is to be provided with the Construction Certificate application for the proposed building, either by using:*

- The Verification Methods in Clause FV1; or
- Other verification methods deemed acceptable by the Certifier; or
- Evidence to support that the use of the material or product, form of construction or design meets the Performance Requirements or the DTS provisions, such as a Certificate of Conformity (eg. CodeMark); or
- By way of Expert Judgement.

**+ Clause F1.1 – Stormwater drainage**

Stormwater drainage must comply with AS/NZ 3500.3.

*Comments: Details of stormwater disposal, from a suitably qualified consultant are required to be submitted with documentation for the CC.*

**+ Clause F1.5 – Roof Coverings**

This clause details the materials and appropriate standards, with which roofs must be covered with. The roofing requirements are set out in sub-clauses (a), (b) (c), (d), (e) & (f) which identifies the types of materials that may be used and the adopted Australian Standards that apply to their quality and installation.



Comments: Note – design certification required at CC Application stage.

+ **Clause F1.6 – Sarking**

Sarking-type materials used for weatherproofing of roofs must comply with AS/NZS 4200 parts 1 and 2.

Comments: Note.

+ **Clause F1.7 – Waterproofing of Wet Areas**

This clause requires that wet areas in Class 2 to 9 buildings must be waterproofed. It prescribes the standards to which the work must be carried out in sub-clauses (a) to (e) with emphasis in sub-clauses (c), (d) & (e) on the construction of rooms containing urinals and their installation.

**Note: Figures F1.7(1) & F1.7(2)** of the Guide to the BCA contain diagrams indicating the areas of walls and floors to be protected around baths, washbasins and showers.

Comments: Note – installation certification will be required at OC Application stage.

+ **Clause F1.13 – Glazed Assemblies**

Glazed assemblies in an external wall must comply with AS2047 requirements for resistance to water penetration for windows, sliding doors with a frame, adjustable louvres, shop fronts and windows with one-piece framing

Comments: Details to be provided with the application for the Construction Certificate.

## SANITARY AND OTHER FACILITIES

+ **Clause F2.3 – Facilities in Class 3 to 9 Buildings**

This clause provides the requirements for sanitary facilities to be installed in Class 3, 5, 6, 7, 8 and 9 buildings in accordance with **Table F2.3**. The requirements and variations are set out in sub-clauses (a)-(h).

Comments: The following assessment of the proposed facilities has been carried out based on the population numbers under D1.13.

Warehouse (Class 7b):

- 248 Males: 13 pans, 6 urinals, 13 washbasins.
- 248 Females: 17 pans, 13 washbasins

Main Office (Class 5):

- 55 Males: 3 pans, 3 urinals & 2 washbasins
- 55 Females: 4 pans & 2 washbasins

Dock Offices (Class 5):

- 19 Males: 1 pan, 1 urinal & 1 washbasins
- 19 Females: 2 pans & 1 washbasins

VAS Office (Class 5):

- 16 Males: 1 pan, 1 urinal & 1 washbasins
- 16 Females: 1 pans & 1 basins

As noted above in D1.13, the population numbers may be considered excessive for the proposed building and as such, more accurate population numbers may be provided by DHL at CC application stage in order to assess compliance with the required number of facilities under F2.3.

+ **Clause F2.4 – Accessible Sanitary Facilities**

Accessible unisex sanitary compartments must be provided, in accordance with **Table F2.4(a)** and unisex showers must be provided in accordance with **Table F2.4(b)**, in buildings or parts that are required to be accessible. The details for the provision of accessible & ambulant facilities and the standard, AS 1428.1, are set out in sub-clauses (a) to (i).

Comments: The proposed accessible and ambulant sanitary facilities must achieve compliance with the provisions of Table F2.4. Details demonstrating that the design of each facility complies with AS 1428.1-2009 are to be provided at the CC application stage, however, compliance is readily achievable.



## ROOM HEIGHTS

### + **Clause F3.1 – Height of Rooms and Other Spaces**

The ceiling heights in Class 2 to 9 buildings must not be less than required in sub-clauses (a) to (f) of this clause.

The minimum ceiling heights for a Class 5, 7 & 8 building are as follows:

- Corridor or Passage, Bathroom, Storeroom, etc. – 2.1m
- Remainder – 2.4m.

*Comments: Architect to ensure compliance. Ceiling heights to be reviewed at the CC application stage with the detailed section drawings.*

## LIGHT AND VENTILATION

### + **Clause F4.4 – Artificial Lighting**

Artificial lighting is required where it is necessary to minimise the hazard to occupants during an emergency evacuation. Sub-clauses (a), (b) & (c) sets out the places where artificial lighting is always required in all classes of buildings and the standard to which it must be installed.

*Comments: Design certification to be submitted at CC Application Stage.*

### + **Clause F4.5 – Ventilation of Rooms**

A habitable room, office, shop, factory, workroom, sanitary compartment, bathroom, shower room, laundry and any other room occupied by a person for any purpose must have natural ventilation complying with F4.6 or a mechanical or air-conditioning system complying with AS1668.2 and AS/NZS 3666.1.

**Note:** NSW F4.5(b) a mechanical ventilation or air-conditioning system complying with AS 1668.2 – the reference to AS/NZS 3666.1 is deleted from the BCA in NSW as the need to comply with this standard is regulated under the relevant section of the Public Health Act 2010.

*Comments: Design certification to be submitted at CC Stage.*

## 3.6 SECTION J – ENERGY EFFICIENCY

---

### + **Part J1 – Building Fabric**

The provision of insulation to the building envelope will be required in the proposed Building, in accordance with **Clauses J1.0 to J1.6**, and the **Tables therein**, including Thermal Construction General, Roof and Ceiling Construction, Roof lights, Walls, and Floors. Design details and/or certification of design will be required to be provided in this regard.

*Comments: This section applies to any air-conditioned spaces proposed within the building. Design details and / or certification of building envelope design will be required to be submitted with the application for a Construction Certificate.*

### + **Part J3 – Building Sealing**

The proposed building envelope will be required to be sealed to prevent air infiltration in accordance with the requirements of **Clauses J3.0 to J3.6**. Details or certification that the proposed building design complies with the requirements of **Part J3** is required to be provided.

*Comments: This section applies to any air-conditioned spaces proposed within the building. Details and / or certification that the proposed design complies with the requirements of **Part J3** will need to be submitted with the application for a Construction Certificate.*

### + **Part J5 – Air-Conditioning & Ventilation Systems**

Details and/or design certification which confirm that any proposed air-conditioning system or unit within the proposed building achieves compliance with the relevant requirements of **Part J5** will be required to be provided from the mechanical engineer.

*Comments: Details or certification demonstrating compliance will need to be submitted with the application for a Construction Certificate.*



**+ Part J6 – Artificial Light & Power**

Details and/or design certification which confirm that all artificial lighting, power control, and boiling/chilled water units within the proposed building achieves compliance with the relevant requirements of **Part J6** will be required to be provided from the electrical engineer.

*Comments: Details or certification demonstrating compliance will need to be submitted with the application for a Construction Certificate.*

**+ Part J7 – Hot Water Supply, & Swimming Pool & Spa Pool Plant**

Details and/or design certification which confirm that any proposed hot water supply system within the proposed building achieves compliance with the relevant requirements of **Part J7** (Section 8 of AS 3500.4) will be required to be provided from the hydraulic engineer.

*Comments: Details or certification demonstrating compliance will need to be submitted with the application for a Construction Certificate.*

**+ Part J8 – Facilities for Energy Monitoring**

Provision for monitoring of energy consumption must be provided to a building where the floor area exceeds 500m<sup>2</sup>, and must be capable of recording the consumption of gas and electricity. In addition, where the floor area of the building exceeds 2,500m<sup>2</sup> the energy monitoring facilities must be capable of individually recording air-conditioning, lighting, appliance power, central hot water supply, lifts/escalators, and other ancillary plant.

*Comments: Details or certification demonstrating compliance will need to be submitted with the application for a Construction Certificate.*



## 4.0 SUMMARY OF KEY COMPLIANCE ISSUES

The following comprises a summary of the key compliance issues identified under the assessment contained above in this report and includes the required Performance Solutions. These matters are to be addressed prior to issue of the Construction Certificate.

### 4.1 MATTERS REQUIRING FURTHER RESOLUTION / NON-FIRE SAFETY PERFORMANCE SOLUTIONS

BCA Clause/s		Description
1.	D1.13	Population Numbers in the Warehouse to be confirmed by DHL
2.	D3.3 & D3.4	Details of any proposed Clause D3.4 exemptions to be provided.
3.	FP1.4	A Performance Solution report is to be provided by the Architect / Façade Engineer to demonstrate how the external walls & roof are designed to prevent the penetration of water into the buildings.
4.	F2.3	Sanitary Facilities requirements to be re-assessed upon confirmation of population numbers by DHL.
5.	Section J	A Section J Compliance Report or JV3 Report will be required at CC application stage for the building.

### 4.2 MATTERS TO BE ADDRESSED AS FIRE SAFETY ENGINEERED PERFORMANCE SOLUTIONS

BCA Clause/s		Description
1.	C2.4	Perimeter Vehicular Access is greater than 18m from the external walls of the buildings.
2.	D1.4 / D1.5	The distance to the nearest exit and between alternative exits is non-compliant in the Warehouse.
3.	E1.3	Where hydrants that are located outside the building are not open to the sky (e.g. located under an awning or the like) and are proposed to be treated as external hydrants, and/or where external hydrants are not proposed to be provided with a radiant heat shield, a Performance Solution will be required. Additionally, details of the hydrant booster locations are to be provided to determine if it is required to be addressed as a Performance Solution.
4.	E1.5	The location of the sprinkler booster assembly will be required to be addressed as a Performance Solution.
5.	E2.2	A Performance Solution may be considered to rationalise the smoke hazard management requirements within the buildings.



## 5.0 CONCLUSION

This report contains an assessment of the referenced architectural documentation for the proposed warehouse development at the 813 Wallgrove Road, Horsley Park against the Deemed-to-Satisfy Provisions of the BCA 2019 Amendment 1. Arising from the review, it is considered that the proposed development can readily achieve compliance with the relevant provisions of the BCA. Where compliance matters are proposed to comply with the Performance Requirements (rather than DtS Provisions), the development of a Performance Solution Report will be required prior to the issue of the Construction Certificate.

The following fire safety measures are required for the new buildings:

<b>Statutory Fire Safety Measure</b>	<b>Design / Installation Standard</b>
Alarm Signaling Equipment	AS 1670.3 – 2018
Automatic Fire Detection & Alarm System (Smoke Exhaust)	BCA Spec. E2.2a & AS 1670.1 – 2018
Automatic Fire Suppression Systems	BCA Spec. E1.5 & AS 2118.1 – 2017
Building Occupant Warning System activated by the Sprinkler System	BCA Spec. E1.5, Clause 8 and / or Clause 3.22 of AS 1670.1 – 2018
Emergency Lighting	BCA Clause E4.4 & AS 2293.1 – 2018
Exit Signs	BCA Clauses E4.5, E4.6 & E4.8; and AS 2293.1 – 2018
Fire Control Centre	BCA Spec. E1.8
Fire Doors	BCA Clause D2.8 and AS 1905.1 – 2015 and manufacturer's specification
Fire Hose Reels (Class 7b Warehouse Parts Only)	BCA Clause E1.4 & AS 2441 – 2005
Fire Hydrant Systems	BCA Clause E1.3 & AS 2419.1 – 2005
Fire Seals	BCA Clause C3.15, AS 1530.4 – 2014 & AS 4072.1 – 2005 and manufacturer's specification
Lightweight Construction	BCA Clause C1.8 & AS 1530.4 – 2014 and manufacturer's specification
Paths of Travel	EP&A Regulation Clause 186
Perimeter Vehicular Access	BCA Clause C2.4
Portable Fire Extinguishers	BCA Clause E1.6 & AS 2444 – 2001
Smoke Hazard Management Systems (Automatic Smoke Exhaust System)	BCA Part E2 & AS/NZS 1668.1 – 2015
Warning & Operational Signs	AS 1905.1 – 2015, BCA Clause D3.6 & E3.3



## 6.0 APPENDIX 1 – SPEC. C1.1 FRL REQUIREMENTS (TYPE C CONSTRUCTION)

Building Element	Class of building — FRL: (in minutes) <i>Structural adequacy/Integrity/Insulation</i>			
	2, 3 or 4 part	5, 7a or 9	6	7b or 8
<b>EXTERNAL WALL</b> (including any column and other building element incorporated within it) or other external building element, where the distance from any <i>fire-source feature</i> to which it is exposed is—				
<i>For loadbearing parts—</i>				
less than 1.5 m	90/ 90/ 90	90/90/90	90/90/90	90/90/90
1.5 to less than 3 m	—/—/—	60/60/60	60/60/60	60/60/60
3 m or more	—/—/—	—/—/—	—/—/—	—/—/—
<b>EXTERNAL COLUMN</b> not incorporated in an <i>external wall</i> , where the distance from any <i>fire-source feature</i> to which it is exposed is—				
less than 1.5 m	90/—/—	90/—/—	90/—/—	90/—/—
1.5 to less than 3 m	—/—/—	60/—/—	60/—/—	60/—/—
3 m or more	—/—/—	—/—/—	—/—/—	—/—/—
<b>COMMON WALLS and FIRE WALLS—</b>	90/ 90/ 90	90/90/90	90/90/90	90/90/90
<b>INTERNAL WALLS—</b>				
Bounding public corridors, public lobbies and the like –	60/60/ 60	—/—/—	—/—/—	—/—/—
Between or bounding sole-occupancy units –	60/60/ 60	—/—/—	—/—/—	—/—/—
Bounding a stair if required to be rated –	60/60/ 60	60/60/ 60	60/60/ 60	60/60/ 60
<b>ROOFS</b>	—/—/—	—/—/—	—/—/—	—/—/—