

M^CLAREN TRAFFIC ENGINEERING

Address: Shop 7, 720 Old Princes Highway Sutherland NSW 2232
Postal: P.O Box 66 Sutherland NSW 1499

Telephone: +61 2 8355 2440

Fax: +61 2 9521 7199

Web: www.mclaretraffice.com.au

Email: admin@mclaretraffice.com.au

Division of RAMTRANS Australia ABN: 45067491678 RPEQ: 19457

Transport Planning, Traffic Impact Assessments, Road Safety Audits, Expert Witness

5 July 2023

Reference: 230217.01FA

Morrison Design Partnership
Suite 302, 69 Christie Street
St Leonards NSW 2065
Attention: Rachel Story

PRELIMINARY CONSTRUCTION TRAFFIC MANAGEMENT PLAN OF RESIDENTIAL AGED CARE FACILITY & INDEPENDENT LIVING UNITS AT 50 - 88 PARRAWEEEN STREET & 59 - 67 GERARD STREET, CREMORNE

Dear Rachel ,

Reference is made to your request to provide a preliminary Construction Traffic Management Plan (CTMP) for the Residential Aged Care Facility & Independent Living at 50 – 88 Parraween Street & 59 – 67 Gerard Street, Cremorne. This Construction Traffic Management Plan (CTMP) is to address the Secretary's Environmental Assessment Requirements.

It is recommended that a CTMP be formally conditioned as part of the development application due to any associated changes to this CTMP as more detailed information becomes available after the development application stage. It is noted that the information contained within this CTMP is preliminary in nature, and will be modified throughout the detailed preparation of a CTMP when further information in relation to truck sizes, build methodology and vehicle movements are known from the builder.

1 Site Location

The subject site has two (2) road frontages to Parraween Street to the south and Gerard Street to the north. In addition to this, 50 Parraween Street has frontage to an unnamed laneway at the rear of the site. The site is currently occupied by a mix of single dwellings and residential flat buildings on each lot and vehicular access to each lot is provided either from Parraween Street or Gerard Street.

The site is located within close proximity to commercial and retail facilities, with the southern side of Parraween Street being zoned *MU1 – Mixed Use* under the *North Sydney Local Environmental Plan 2013*. The subject site is currently zoned *R4 – High Density Residential* and is subject to the *North Sydney Development Control Plans 2013*.

Gerard Street

- TfNSW Classified Regional Secondary Road (No. 2036);
- Approximately 13m wide two-way carriageway facilitating two lanes in each direction and kerbside parking;
- Signposted 50km/h speed limit;
- Signposted “Clearway 6:00 AM – 10:00 AM, MON – FRI” along the southern side of the road and “Clearway 3:00 PM – 7:00 PM, MON – FRI” along the northern side of the road.

Parraween Street

- Unclassified Local Road;
- Approximately 12m wide two-way carriageway facilitating one traffic-flow lane in each direction with intermittent parking available along both sides of the road with 90-degree and parallel parking provided;
- Signposted 40km/h speed limit;
- Time-restricted and metered parking of varying periods available along intermittently along both sides of the road, including both 90-degree and parallel parking;
- Linemarked motorcycle parking spaces available along the northern side of the road in close proximity to the site.

2 Proposed Development

The proposed development has the following characteristics relevant to traffic and parking impacts for the purposes of this assessment:

- Construction of a residential Aged Care Facility (RACF) and Independent Living Units (ILU) including:
 - 41 x beds for Residential (Aged) Care;
 - 14 staff required to operate and assist the residential aged care and the ancillary uses associated with the ILU and aged care facility. The ancillary uses of the site consist of the following:
 - Pool;
 - RACF dining areas and ILU dining areas;
 - Lounge areas;
 - Mens Shed;
 - Beauty / Hair areas.
 - 58 x Seniors Living dwellings.
- Basement parking levels with vehicular access via a two-way driveway from Parraween Street accommodating 134 car parking spaces and loading facilities (reduced parking provided when considering accessible requirements).
- A loading dock is proposed to accommodate two (2) loading bays with both spaces capable of accommodating vehicles up to an 8.8m length Medium Rigid Vehicle (including ambulances).

3 Public Transport

The subject site has access to existing bus stop (ID: 209036) located approximately 260m walking distance to the south of the site on Military Road. The bus stop services the following existing bus routes provided by Keolis Downer Northern Beaches:

- 100 (Taronga Zoo to City QVB [Loop Service]);
- 114 (Balmoral to Royal North Shore Hospital);
- 144 (Manly to Chatswood via St Leonards);
- 150X (Manly to Milsons Point [Express Service]);
- 165X (South Curl Curl to City Wynyard [Express Service]);
- 170X (Manly to City Wynyard [Express Service]);
- 172X (Warringah Mall to City Wynyard via North Balgowlah [Express Service]);
- 173X (Warringah Mall to City Wynyard via Balgowlah Shops [Express Service]);
- 174X (Narraweena to City Wynyard [Express Service]);
- 176X (Dee Why to City Wynyard via North Curl Curl [Express Service]);
- 177X (Dee Why to City Wynyard via Wingala [Express Service]);
- 228 (Clifton Gardens to Milsons Point);
- 229 (Beauty Point to Milsons Point via Balmoral Heights);
- 230 (Mosman Wharf to Milsons Point via North Sydney);
- 246 (Balmoral Heights to City Wynyard);
- 249 (Beauty Point to City Wynyard).

The location of the site subject to the surrounding public transport network is shown in Error! Reference source not found. below.

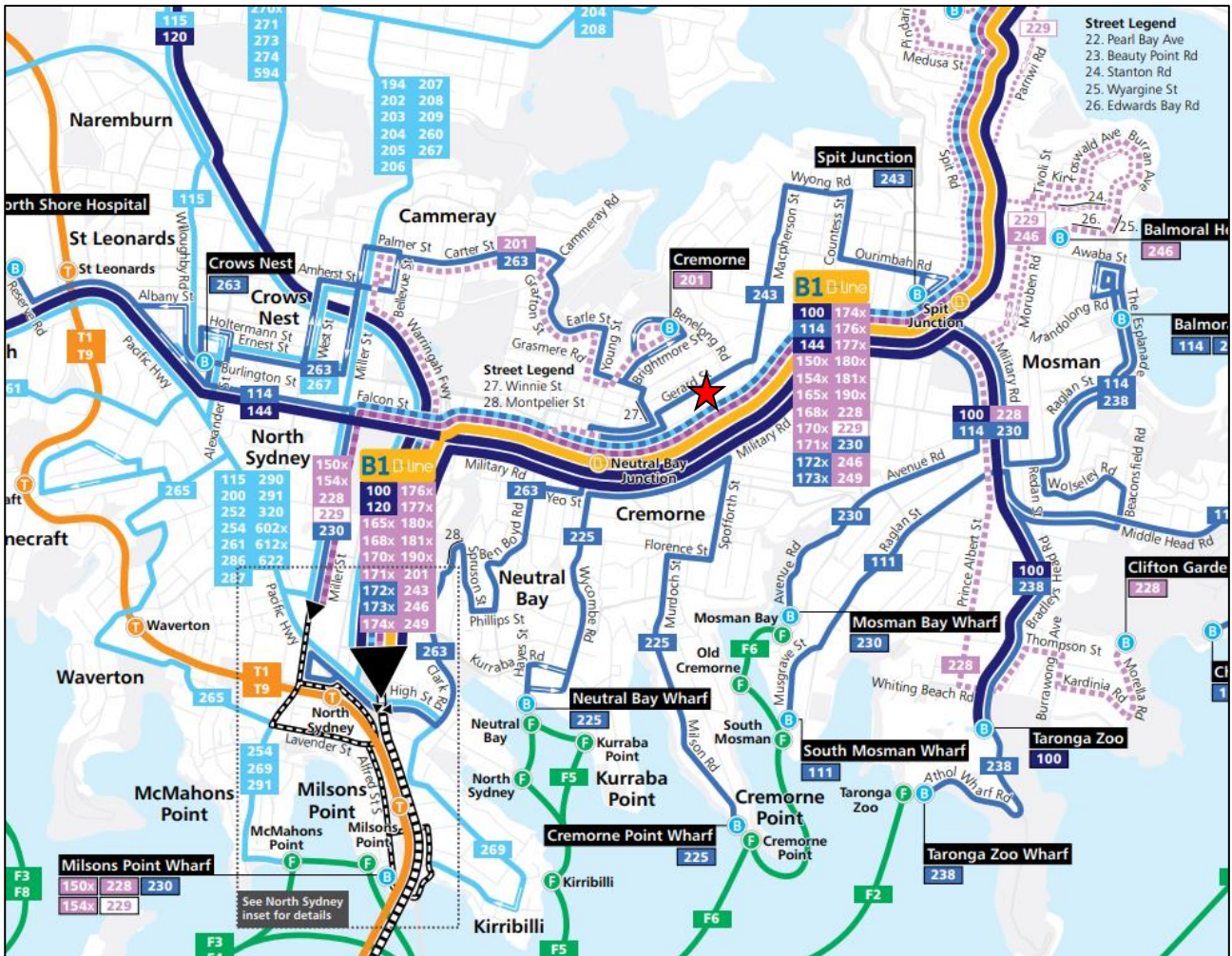

 Site Location

4 Duration of Construction

Construction is expected to occur over a total duration of 6 months. The expected milestones and durations are as follows.

TABLE 1: DURATION OF CONSTRUCTION STAGES

Activity	Duration
Demolition & Excavation	8 months
Structure	12 months which overlaps with 5 months of the excavation
Fit out	8 months which overlaps with the 7 months of structure
Total	16 months

This timeframe is indicative only and can possibly change due to delays, weather and construction certification details.

5 Construction Hours of Work

The work associated with the construction of the development shall be carried out between the general hours of construction as stated within the Council conditions of consent, which is typical for all CTMP.

Typical hours of construction are 7 am to 5 pm Mondays to Fridays and between 8 am and 1 pm on Saturday. No work is to be carried out on Sunday or public holidays.

The enforcement of these hours and conditions of work is the responsibility of the site contractor and any other delegated authority. All sub-contractors and associated workmen are to follow the hours and conditions of work as instructed by the site contractor. Any works or activities outside of the approved hours of work must be approved by Council prior to carrying out the work.

6 Construction Site Access

Considering the location and constraint of the site and surrounding environs, it is considered that construction vehicle will be capable of entering and exiting the site in a forward direction during construction, especially demolition and excavation stages. During construction of the buildings, a Works Zone will be required along both site frontages for construction deliveries and concrete pours to take place. Both frontages of the site from Gerard Street and Parraween Street have large frontages to facilitate the temporary use of a Works Zone.

During the excavation and demolition stages, all construction vehicle access to and from the site will be in a forward direction, with the use of proposed Works Zone during construction, concrete pours and fitout to be operated as forward in / forward out where possible to do so. Any reverse movements into or out of the site and Works Zone will be the subject of a Traffic Guidance Scheme, but reverse movements will be avoided where possible to avoid and temporary delays to the road network and to maximise pedestrian safety.

Gerard Street and Parraween Street have direct access from an arterial road, being Military Road. An assessment of the largest vehicle that will access each street from the arterial road network will be assessed as part of the detailed CTMP as part of the conditions of consent.

If warranted under the detailed assessment, the following can be considered:

- Limiting large vehicle access to Parraween Street (limited to 12.5m length Heavy Rigid Vehicle or truck and dog combinations [no articulated vehicles]);
- Larger vehicle deliveries can be undertaken from Gerard Street (limited to 20m length Articulated Vehicles);
- Limitation imposed on the use of Parraween Street during high pedestrian periods of the nearby shops on the southern side of Parraween Street (i.e. Saturday and Sundays).

Further, any damage done to Council property including the existing road, verge or street trees along Gerard Street or Parraween Street by construction traffic related to the subject site is to be repaired as part of the dilapidation survey and bond.

An appropriate washing facility will be provided on-site within the property boundary at each driveway along with cattle grid shakers at the vehicular entries/exits to prevent spoil material being tracked off the site onto surrounding roadways.

7 Work Zones

During construction of the buildings, a Works Zone will be required along both site frontages for construction deliveries and concrete pours to take place. Both frontages of the site from Gerard Street and Parraween Street have large frontages to facilitate the temporary use of a Works Zone.

The use of proposed Works Zone during construction, concrete pours and fitout to be operated as forward in / forward out where possible to do so. Any reverse movements into or out of the Works Zone will be the subject of a Traffic Guidance Scheme, but reverse movements will be avoided where possible to avoid and temporary delays to the road network and to maximise pedestrian safety.

Type B hoarding must be installed on the site boundaries of Gerrard and Parraween Streets, whilst Class A hoarding will be installed along all other boundaries. Type B hoardings will permit safe access within the public domain along Gerard Street and Parraween Streets during the use of construction vehicles.

8 Construction Staff & Parking Requirements

The expected staff requirements for the construction are as follows:

TABLE 2: EXPECTED CONSTRUCTION STAFF VOLUMES

Activity	Average Number of Staff on site	Maximum expected Staff on-site at any one time
Demolition	20	30
Excavation	15	25
Structure	60	150
Fitout	60	150

It is expected that as a worst case, an average of 60 works will be on-site during the structure and fitout periods, whilst a absolute maximum of 150 works will be on-site during rare occasions (typically corresponding to concrete pours).

The peak traffic generation for construction workers will generally occur early in the morning (7am) and finish in the afternoon (3-5pm). Construction worker traffic does not typically coincide with either heavy construction vehicular traffic or commuter traffic peak hours.

The contractor shall encourage carpooling amongst construction staff as well as the use of public transport where possible to minimise private vehicle use. The use of available public transport (as detailed in **Section 3**) and utilisation of carpooling is considered reasonable and should be utilised by all construction staff who do not require the explicit use of their own vehicle.

When the basement is constructed and certified (if necessary), it will be capable of accommodating staff parking demand during the structure and fitout stages, alleviating overflow parking during the internal finish / fitout period which generates the highest staff parking demand.

9 Construction Traffic

An estimate of the construction traffic generated by the works is summarised in **Table 3** below.

TABLE 3: EXPECTED CONSTRUCTION TRAFFIC

Stage	Number of Trucks	Largest Truck
Demolition	6 x waste collection vehicles per day	19m length Truck and Dog
Excavation	15 x construction vehicle per day 1 x waste collection vehicles per day	19m length Truck and Dog & 19m-20m length Articulated Vehicle
Structure	5 x construction vehicles per day 2 x waste collection vehicle per day	
Fitout	10 x construction vehicles per day 2 x waste collection vehicle per day	
Concrete Pours	Peak of 30 x concrete trucks per pour (typically maximum 6 concrete trucks per hour); A total of 20 major concrete pours	

Construction traffic generated by the development is relatively low, with a peak of 10 hourly construction vehicle movements expected during normal operations. These movements by construction vehicles will generally occur throughout the day. Heavy construction vehicular traffic does not typically coincide with either commuter traffic AM or PM peak hours or construction worker traffic generation which will generally occur early in the morning (7:00am) and finish in the afternoon from 3:00pm to 5:00pm.

The absolute maximum construction generated by the proposal will occur during major concrete pours, where there will be a maximum of 6 concrete trucks per hour, relating to a maximum of 12 vehicle movements (6 in, 6 out).

The level of private vehicle traffic in conjunction with the heavy vehicle traffic specified in **Table 3** above is not expected to have a significant or lasting adverse impact on the surrounding road network. Construction traffic will be easily managed by the site contractor who will coordinate all deliveries including concrete trucks.

10 Construction Vehicle Haulage

All construction vehicles required to access the site will utilise the existing road network. Gerard Street and Parraween Street have direct access from an arterial road, being Military Road. An assessment of the largest vehicle that will access each street from the arterial road network will be assessed as part of the detailed CTMP as part of the conditions of consent.

If warranted under the detailed assessment, the following can be considered:

- Limiting large vehicle access to Parraween Street (limited to 12.5m length Heavy Rigid Vehicle or truck and dog combinations [no articulated vehicles]);

- Larger vehicle deliveries can be undertaken from Gerard Street (limited to 20m length Articulated Vehicles);
- Limitation imposed on the use of Parraween Street during high pedestrian periods of the nearby shops on the southern side of Parraween Street (i.e. Saturday and Sundays).

11 Pedestrian Management

The site frontages along Gerard Street and Parraween Street have existing pedestrian footpaths. On the outside of the construction fence, these frontages are to be free of any waste, construction material or trip hazards associated with the development. Site fencing along the frontages should also be regularly inspected for potential trip hazards or encroachment onto the verge where pedestrians will walk. Only authorised personnel are permitted on-site in areas restricted by construction fencing and must be inducted by the site manager/OH&S officer.

As a construction work zone is required along both Gerard Street / Parraween Street in front of the site, it will be necessary to implement type B hoarding to ensure pedestrian access is maintained along the frontage roads.

12 Traffic Control Plans

Traffic Guidance Schemes (TGS) will be prepared as part of the provision of a detailed CTMP as part of the conditions of consent. The installation and implemented of TGS are to be installed by a suitably qualified contractor. The TGS's are based on Roads & Maritime Services (RMS) Traffic Control at Worksites and AS1742.3:2009.

A minimum of fourteen (14) days notification must be provided to adjoining property owners prior to the implementation of any temporary traffic control measure. Implementation of the TGS shall be installed by a suitably qualified contractor for the duration of the proposed construction.

13 Traffic Management Plan (TMP) Checklist

Reference is made to the RMS (previously RTA) *Procedures for Use in the Preparation of a Traffic Management Plan*, version 2.0 December 2001. The following list addresses the required TMP details.

- A. Description or detailed plan of proposed measures
Is the detailed plan of the proposed measures necessary?
Yes
- B. Identification and assessment of impact of proposed measures
Is a detailed assessment required?
No – The expected generated construction traffic is relatively low and is not expected to measurably increase prevailing delays or adversely impact the surrounding road network performance.
- C. Measures to ameliorate the impact of re-assigned traffic
Is an assessment required?
No – The expected generated construction traffic is relatively low and is not expected to measurably increase prevailing delays or adversely impact the surrounding road network performance. Haulage routes will maximise the use of existing arterial, such as Military Road within close proximity to the site.
- D. Assessment of public transport services affected
Is an assessment required?
No – there are no existing bus stops which will be affected by the proposed works. The required staff levels are also not expected to add loading above what the surrounding public transport network can currently accommodate with its current services and frequency. As such, existing public transport services will not be affected.
- E. Details of provision made for emergency vehicles, heavy vehicles, cyclists and pedestrians
Are these details required?
No – the proposed works will not adversely impact the current on-street conditions for emergency or heavy vehicles. Access around the site for pedestrians will also be maintained at all times.
- F. Assessment of effect on existing and future developments with transport implications in the vicinity of the proposed measures
Is an assessment required?
No – There are no known existing or future development with transport implications in the vicinity of the site.
- G. Assessment of effect of proposed measures on traffic movements in adjoining Council areas
Is an assessment required?
No – The expected generated construction traffic is relatively low and is not expected to measurably increase prevailing delays or adversely impact the surrounding road network performance. There are no external measures proposed that will create traffic movement changes in adjoining council areas.
- H. Public consultation process
Is a public consultation process required?
No - Construction vehicle traffic is minimal such that no impacts to residential amenity will occur during construction. Additionally, no long-term signage or changes to existing on street conditions will occur as part of the construction. Hence, Council can determine this construction proposal accordingly without referral to the public. The builder / site manager

shall provide a minimum 14 days notification to adjoining property owners prior to the implementation of the proposed traffic control measures.

Please contact the undersigned on 9521 7199 should you require further information or assistance.

Yours faithfully,

McLaren Traffic Engineering
Matthew McCarthy



Senior Traffic Engineer

Bachelor of Civil Engineering

Masters of Engineering Science

Accredited Level 2 Road Safety Auditor

Accredited Traffic Management Plan Designer

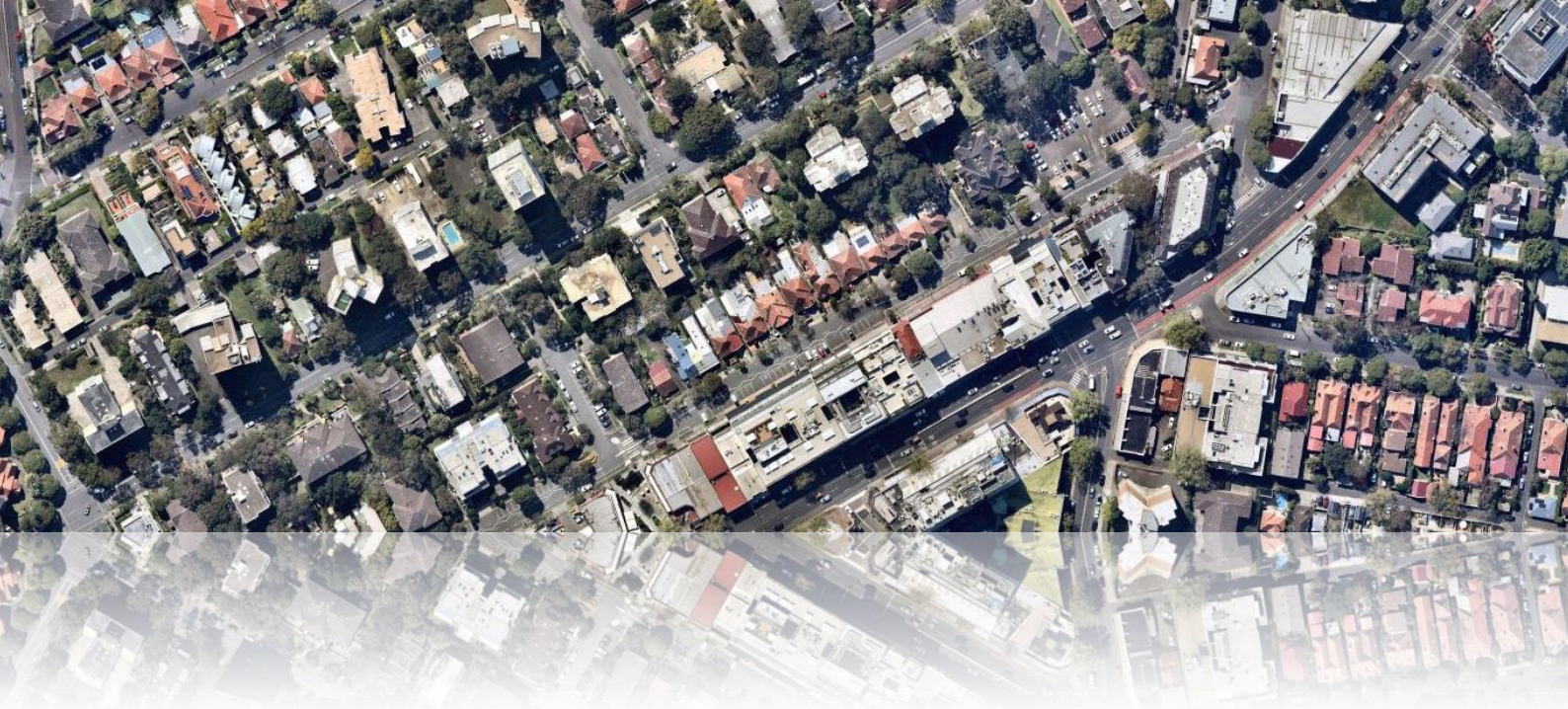

**TRAFFIC AND PARKING IMPACT ASSESSMENT OF
THE PROPOSED SENIORS HOUSING DEVELOPMENT
AT 50 - 88 PARRAWEEEN STREET & 59-67 GERARD STREET, CREMORNE**



**Address: Shop 7, 720 Old Princes Highway Sutherland NSW 2232
Postal: P.O Box 66 Sutherland NSW 1499**

**Telephone: +61 2 9521 7199
Web: www.mclarentraffic.com.au
Email: admin@mclarentraffic.com.au**

Division of RAMTRANS Australia ABN: 45067491678 RPEQ: 19457

Transport Planning, Traffic Impact Assessments, Road Safety Audits, Expert Witness

Development Type: Proposed Seniors Housing Development

Site Address: 50 - 88 Parraween Street & 59-67 Gerard Street, Cremorne

Prepared for: Morrison Design Partnership Architects

Document reference: 220518.01FA

Status	Issue	Prepared By	Checked By	Date
Draft	A	LS/MM	LS	9 June 2023
Draft	B	MM	LS/ CM	30 June 2023
Final	A	MM	LS/ CM	5 July 2023

Please be aware that all information and material contained in this report is the property of McLaren Traffic Engineering. The information contained in this document is confidential and intended solely for the use of the client for the purpose for which it has been prepared and no representation is made or if to be implied as being made to any third party. Any third party wishing to distribute this document in whole or in part for personal or commercial use must obtain written confirmation from McLaren Traffic Engineering prior to doing so. Failure to obtain written permission may constitute an infringement of copyright and may be liable for legal action.

Certification of Traffic & Parking Impact Assessment Report

Registered Professional Engineer Queensland & Throughout Australia

Project Title	Traffic and Parking Impact Assessment of the Proposed Seniors Housing Development at 50 - 88 Parraween Street & 59-67 Gerard Street, Cremorne
----------------------	---

As a professional engineer registered by the Board of Professional Engineers of Queensland pursuant to the *Professional Engineers Act 2002* as competent in my areas of nominated expertise throughout Australia, I understand and recognise:

- the significant role of engineering as a profession, and that
- the community has a legitimate expectation that my certification affixed to this engineering work can be trusted, and that
- I am responsible for ensuring his preparation has satisfied all necessary standards, conduct and contemporary practise.

As the responsible RPEQ, I certify:

- a) I am satisfied that all submitted components comprising this traffic & parking impact assessment, listed in the following table, have been completed in accordance with the guides to traffic impact assessment published by the Transport for New South Wales / AUSTRROADS and using sound engineering principles, and
- b) where specialised areas of work have not been under my direct supervision, I have reviewed the outcomes of the work and consider the work and its outcomes as suitable for the purposes of this traffic impact assessment, and that
- c) the outcomes of this traffic and parking impact assessment are a true reflection of results of assessment, and that
- d) I believe the strategies recommended for mitigating impacts by this traffic and parking impact assessment, embrace contemporary practise initiatives and will deliver the desired outcomes.

Name:	Craig McLaren	RPEQ No.	19457
RPEQ Competencies:	Traffic Engineering Transport Planning Road Safety		
Signature:		Date:	23/06/2023
Postal Address:	P.O Box 66 Sutherland NSW 1499		
Email:	admin@mclarentraffic.com.au		

TABLE OF CONTENTS

1	INTRODUCTION.....	1
1.1	Description and Scale of Development	1
1.2	State Environmental Planning Policy (Transport and Infrastructure) 2021	2
1.3	Site Description.....	2
1.4	Site Context	2
2	SECRETARY’S ENVIRONMENTAL ASSESSMENT REQUIREMENTS	4
3	EXISTING TRAFFIC AND PARKING CONDITIONS	5
3.1	Road Hierarchy	5
3.1.1	Gerard Street.....	5
3.1.2	Parraween Street.....	5
3.1.3	Unnamed Laneway.....	5
3.2	Existing Traffic and Pedestrian Management.....	6
3.3	Existing Traffic Volumes	6
3.3.1	Existing Road Performance	7
3.4	Public Transport.....	9
3.5	Future Road and Infrastructure Upgrades.....	10
4	PARKING ASSESSMENT	11
4.1	Council’s DCP Parking Requirements.....	11
4.2	State Environmental Planning Policy (Housing) 2021 Parking Requirements	11
4.2.1	Public Domain	13
4.3	Accessible Parking	14
4.4	Bicycle & Motorcycle Parking Requirements.....	14
4.4.1	Bicycle Parking Requirements.....	14
4.4.2	Motorcycle Parking Requirements.....	15
4.5	Servicing & Loading.....	15
4.6	Green Travel Plan.....	16
4.7	Car Park Design & Compliance	16
5	PEDESTRIAN MANAGEMENT	17
6	TRAFFIC ASSESSMENT	19
6.1	Traffic Generation	19
6.2	Trip Assignment.....	21
6.3	Traffic Impact	22
7	CONSTRUCTION TRAFFIC MANAGEMENT PLAN	24
8	CONCLUSION	26

1 INTRODUCTION

McLaren Traffic Engineering was commissioned by Morrison Design Partnership Architects to provide a Traffic and Parking Impact Assessment of the Proposed Seniors Housing Development at 50 - 88 Parraween Street & 59-67 Gerard Street, Cremorne as depicted in **Annexure A**.

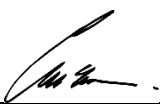
1.1 *Description and Scale of Development*

The proposed development has the following characteristics relevant to traffic and parking impacts for the purposes of this assessment:

- Construction of a residential Aged Care Facility (RACF) and Independent Living Units (ILU) including:
 - 41 x beds for Residential (Aged) Care;
 - 14 staff required to operate and assist the residential aged care and the ancillary uses associated with the ILU and aged care facility. The ancillary uses of the site consist of the following:
 - Pool;
 - RACF dining areas and ILU dining areas;
 - Lounge areas;
 - Mens Shed;
 - Beauty / Hair areas.
 - 58 x Seniors Living dwellings consisting of:
 - 17 x two-bedroom units, and;
 - 40 x three-bedroom units, and;
 - 1 x four-bedroom unit.
- Basement parking levels with vehicular access via a two-way driveway from Parraween Street accommodating 134 car parking spaces and loading facilities (reduced parking provided when considering accessible requirements).
- A loading dock is proposed to accommodate two (2) loading bays with both spaces capable of accommodating vehicles up to an 8.8m length Medium Rigid Vehicle (including ambulances).

1.2 State Environmental Planning Policy (Transport and Infrastructure) 2021

The proposed development has frontage to a classified road (Gerard Street) and therefore qualifies as such with reference to *Clause 2.119 of State Environmental Planning Policy (Transport and Infrastructure) 2021*. The development therefore must satisfy that:

- (a) where practicable and safe, vehicular access to the land is provided by a road other than the classified road, and*
- (b) the safety, efficiency, and ongoing operation of the classified road will not be adversely affected by the development as a result of:*
 - (i) the design of the vehicular access to the land.*
 - (ii) the emission of smoke or dust from the development*
 - (iii) the nature, volume or frequency of vehicles using the classified road to gain access to the land.*

All vehicular access to the site is proposed to be undertaken via a two-way driveway from Parraween Street, an unclassified Local Road. As detailed in **Section 6**, the proposed development is not expected to result in any adverse traffic impacts on the surrounding road network. Accordingly, it is considered that the consent authority (North Sydney Council) is likely to be satisfied that the requirements of *Clause 2.119* are met.

The proposed development does not qualify as a traffic generating development with relevant size and/or capacity under *Clause 2.122 of the SEPP (Transport and Infrastructure) 2021*. Further vehicular access is not via a classified road, either directly or within 90m of a classified road. Accordingly, formal referral to the Transport for NSW (TfNSW) is unnecessary in this regard and the application can be assessed by North Sydney Council officers accordingly.

1.3 Site Description

The subject site has two (2) road frontages to Parraween Street to the south and Gerard Street to the north. In addition to this, 50 Parraween Street has frontage to an unnamed laneway at the rear of the site. The site is currently occupied by a mix of single dwellings and residential flat buildings on each lot and vehicular access to each lot is provided either from Parraween Street or Gerard Street.

The site is located within close proximity to commercial and retail facilities, with the southern side of Parraween Street being zoned *MU1 – Mixed Use* under the *North Sydney Local Environmental Plan 2013*. The subject site is currently zoned *R4 – High Density Residential* and is subject to the North Sydney Development Control Plans 2013.

1.4 Site Context

The location of the site is shown on an aerial photo and a street map in **Figure 1** and **Figure 2** respectively.



— Site Location

FIGURE 1: SITE CONTEXT – AERIAL IMAGE

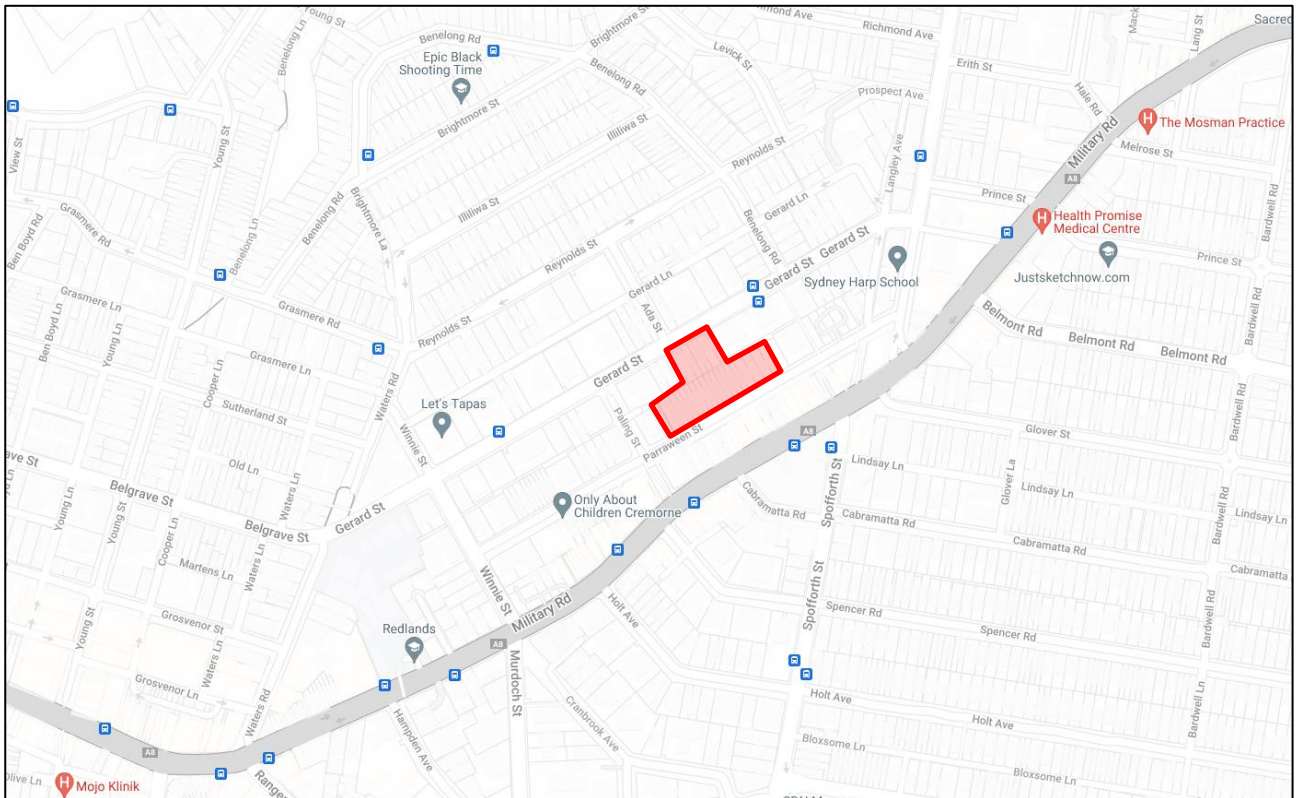

— Site Location

FIGURE 2: SITE CONTEXT – STREET MAP

2 Secretary's Environmental Assessment Requirements

In preparation of this report consideration has been made with respect to the industry-wide *Planning Secretary's Environmental Assessment Requirements* (SEARs) for Seniors Housing developments. **Table 1** outlines the SEARs requirements relevant to traffic and parking.

TABLE 1: SEARS REQUIREMENTS

SEARs Requirements	Addressed in Section
<ul style="list-style-type: none"> • Provide a transport and accessibility impact assessment, which includes: <ul style="list-style-type: none"> ○ An analysis of the existing transport network, including the road hierarchy and any pedestrian, bicycle or public transport infrastructure, current daily and peak hour vehicle movements, and exiting performance levels of nearby intersections. 	Section 3
<ul style="list-style-type: none"> ○ Details of the proposed development, including pedestrian and vehicular access arrangements (including swept path analysis of the largest vehicle and height clearances, and an explanation of how residents will access facilities and services), parking arrangements and rates (including bicycle and end-of-trip facilities), drop-off/pick-up-zone(s) and bus bays (if applicable), and provisions for servicing and loading/unloading. 	Section 1.1, Section 4, Annexure E
<ul style="list-style-type: none"> ○ Analysis of the impacts of the proposed development (including justification for the methodology used), including predicted modal split, a forecast for additional daily and peak hour multimodal network flows as a result of the development (using industry standard modelling), identification of potential traffic impacts on road capacity, intersection performance and road safety (including pedestrian and cyclist conflict) and any cumulative impact from surrounding approved developments. 	Section 5, Section 6
<ul style="list-style-type: none"> ○ Measures to mitigate any traffic impacts, including details of any new or upgraded infrastructure to achieve acceptable performance and safety, and the timing, viability and mechanisms of delivery (including proposed arrangements with local councils or government agencies) of any infrastructure improvements in accordance with relevant standards. 	N/A – No mitigation measures necessary, See Section 6
<ul style="list-style-type: none"> ○ Proposals to promote sustainable travel choices for employees, residents, guests and visitors, such as connections into existing walking and cycling networks, minimising car parking provision, encouraging car share and public transport, providing adequate bicycle parking and high quality end-of-trip facilities, and implementing a Green Travel Plan. 	Section 4.6, Annexure D
<ul style="list-style-type: none"> • Provide a Construction Traffic Management Plan detailing predicted construction vehicle movements, routes, access and parking arrangements, coordination with other construction occurring in the area, and how impacts on existing traffic, pedestrian and bicycle networks would be managed and mitigated. 	Section 7

3 EXISTING TRAFFIC AND PARKING CONDITIONS

3.1 Road Hierarchy

The road network servicing the site has characteristics as described in the following sub-sections.

3.1.1 Gerard Street

- TfNSW Classified Regional Secondary Road (No. 2036);
- Approximately 13m wide two-way carriageway facilitating two lanes in each direction and kerbside parking;
- Signposted 50km/h speed limit;
- Signposted “*Clearway 6:00 AM – 10:00 AM, MON – FRI*” along the southern side of the road and “*Clearway 3:00 PM – 7:00 PM, MON – FRI*” along the northern side of the road.

3.1.2 Parraween Street

- Unclassified Local Road;
- Approximately 12m wide two-way carriageway facilitating one traffic-flow lane in each direction with intermittent parking available along both sides of the road with 90-degree and parallel parking provided;
- Signposted 40km/h speed limit;
- Time-restricted and metered parking of varying periods available along intermittently along both sides of the road, including both 90-degree and parallel parking;
- Linemarked motorcycle parking spaces available along the northern side of the road in close proximity to the site.

3.1.3 Unnamed Laneway

- Unclassified Local Laneway located to the western end of the site, connection to Paling Street;
- Approximately 5m wide two-way carriageway facilitating local property access;
- No speed limit signposted - default 50km/h speed limit applies, although would not operate at this speed;
- No kerbside parking permitted along both sides of the road, with observed 90-degree parking occurring at the eastern end of the laneway.

3.2 Existing Traffic and Pedestrian Management

- Priority-controlled intersection of Gerard Street / Ada Street;
- Priority-controlled intersection of Parraween Street / Paling Street;
- Priority-controlled intersection of Parraween Street / Macpherson Street;
- Priority-controlled intersection of Parraween Street / Winnie Street;
- Raised pedestrian crossings across Parraween Street located to both the east and west of the site.

3.3 Existing Traffic Volumes

Turning movement count surveys were conducted at the intersections of Military Road / Winnie Street, Macpherson Street / Parraween Street, Parraween Street / Winnie Street, Winnie Street / Gerard Street, Gerard Street / Ada Street between 7:00 AM and 9:30 AM & 2:30 PM and 6:00 PM on the Tuesday 26 July 2022, Wednesday 27 July 2022 and Thursday 28 July 2022 representing three (3) typical operating weekdays. The full survey results are shown in **Annexure B** for reference.

The three (3) days that were surveyed, the peak traffic volumes occurred during the following days at the following intersections:

- Military Road / Winnie Street – Wednesday 27 July 2022 in both the AM and PM peak periods;
- Macpherson Street / Parraween Street – Thursday 28 July in the AM Peak and Tuesday 26 July 2022 in the PM peak;
- Parraween Street / Winnie Street – Thursday 28 July 2022 in the AM peak and PM peak;
- Winnie Street / Gerard Street – Thursday 28 July 2022 in the AM peak and PM peak;
- Gerard Street / Ada Street – Tuesday 26 July 2022 in the AM peak and Thursday 28 July 2022 in the PM peak.

For the purposes of determine the existing road performance, the time periods above have been modelled in the following sub-section.

3.3.1 Existing Road Performance

The performance of the surrounding intersections under the existing traffic conditions has been assessed using SIDRA INTERSECTION 9.0, **Table 2** summarises the resultant intersection performance data, with full SIDRA results reproduced in **Annexure C**.

For the purposes of calibration to ensure a realistic model, the following has been considered:

- TCS plans for signalised intersections;
- A detailed Review of video footage of the cycle and phase times;
- Peak flow factor is based upon the surveyed traffic volumes.

TABLE 2: EXISTING INTERSECTION PERFORMANCES (SIDRA INTERSECTION 9.0)

Intersection	Peak Hour	Degree of Saturation ⁽¹⁾	Average Delay ⁽²⁾ (sec/veh)	Level of Service ⁽³⁾⁽⁴⁾	Control Type	Worst Movement
EXISTING PERFORMANCE						
Military Road / Winnie Street	AM	0.87	9.9	A	Signal	NA
	PM	0.89	16.5	B		NA
Macpherson Street / Paraween Street	AM	0.08	N/A (Worst: 5.4)	NA (Worst: A)	Give-Way	RT from Parraween Street
	PM	0.10	N/A (Worst: 6.0)	NA (Worst: A)		RT from Macpherson Street
Parraween Street / Winnie Street	AM	0.23	N/A (Worst: 6.0)	NA (Worst: A)	Give-Way	RT from Parraween Street
	PM	0.18	N/A (Worst: 5.9)	NA (Worst: A)		RT from Winnie Street (S)
Winnie Street / Gerard Street	AM	0.72	19.7	B	Signal	NA
	PM	0.68	16.4	B		NA
Gerard Street / Ada Street	AM	0.45	N/A (Worst: >70)	NA (Worst: F)	Give-way	RT from Ada Street
	PM	0.45	N/A (Worst: >70)	NA (Worst: F)		RT from Ada Street

NOTES:

(1) The Degree of Saturation is the ratio of demand to capacity for the most disadvantaged movement.

(2) The average delay is the delay experienced on average by all vehicles. The value in brackets represents the delay to the most disadvantaged movement.

(3) The Level of Service is a qualitative measure of performance describing operational conditions. There are six levels of service, designated from A to F, with A representing the best operational condition and level of service F the worst. The LoS of the intersection is shown in bold, and the LoS of the most disadvantaged movement is shown in brackets.

(4) No overall Level of Service is provided for Give Way and Stop controlled intersections as the low delays associated with the dominant movements skew the average delay of the intersection. The Level of Service of the worst approach is an indicator of the operation of the intersection, with a worse Level of Service corresponding to long delays and reduced safety outcomes for that approach.

As shown above, the relevant intersections are currently performing at a high level of efficiency, with levels of service of “A” or “B” conditions in both the AM & PM peak hour periods, with the exception of the intersection of Gerard Street / Ada Street. The level of service “A” and “B” performance is characterised by low approach delays and spare capacity.

The intersection of Gerard Street / Ada Street is currently operating with worst turn movement of LoS “F” which is attributed to the right turn from Ada Street into Gerard Street. This particular movement correlates to two (2) vehicle turning right in both the AM and PM peak hour period. This suggests that the operation of the right turn movement from Ada Street into Gerard Street is at capacity, which is evident by the low levels of traffic movements that attempt to turn right at this intersection. This suggests that vehicles would take alternative travel routes and is self-enforceable.

3.4 Public Transport

The subject site has access to existing bus stop (ID: 209036) located approximately 260m walking distance to the south of the site on Military Road. The bus stop services the following existing bus routes provided by Keolis Downer Northern Beaches:

- 100 (Taronga Zoo to City QVB [Loop Service]);
- 114 (Balmoral to Royal North Shore Hospital);
- 144 (Manly to Chatswood via St Leonards);
- 150X (Manly to Milsons Point [Express Service]);
- 165X (South Curl Curl to City Wynyard [Express Service]);
- 170X (Manly to City Wynyard [Express Service]);
- 172X (Warringah Mall to City Wynyard via North Balgowlah [Express Service]);
- 173X (Warringah Mall to City Wynyard via Balgowlah Shops [Express Service]);
- 174X (Narraweena to City Wynyard [Express Service]);
- 176X (Dee Why to City Wynyard via North Curl Curl [Express Service]);
- 177X (Dee Why to City Wynyard via Wingala [Express Service]);
- 228 (Clifton Gardens to Milsons Point);
- 229 (Beauty Point to Milsons Point via Balmoral Heights);
- 230 (Mosman Wharf to Milsons Point via North Sydney);
- 246 (Balmoral Heights to City Wynyard);
- 249 (Beauty Point to City Wynyard).

The location of the site subject to the surrounding public transport network is shown in **Figure 3** below.

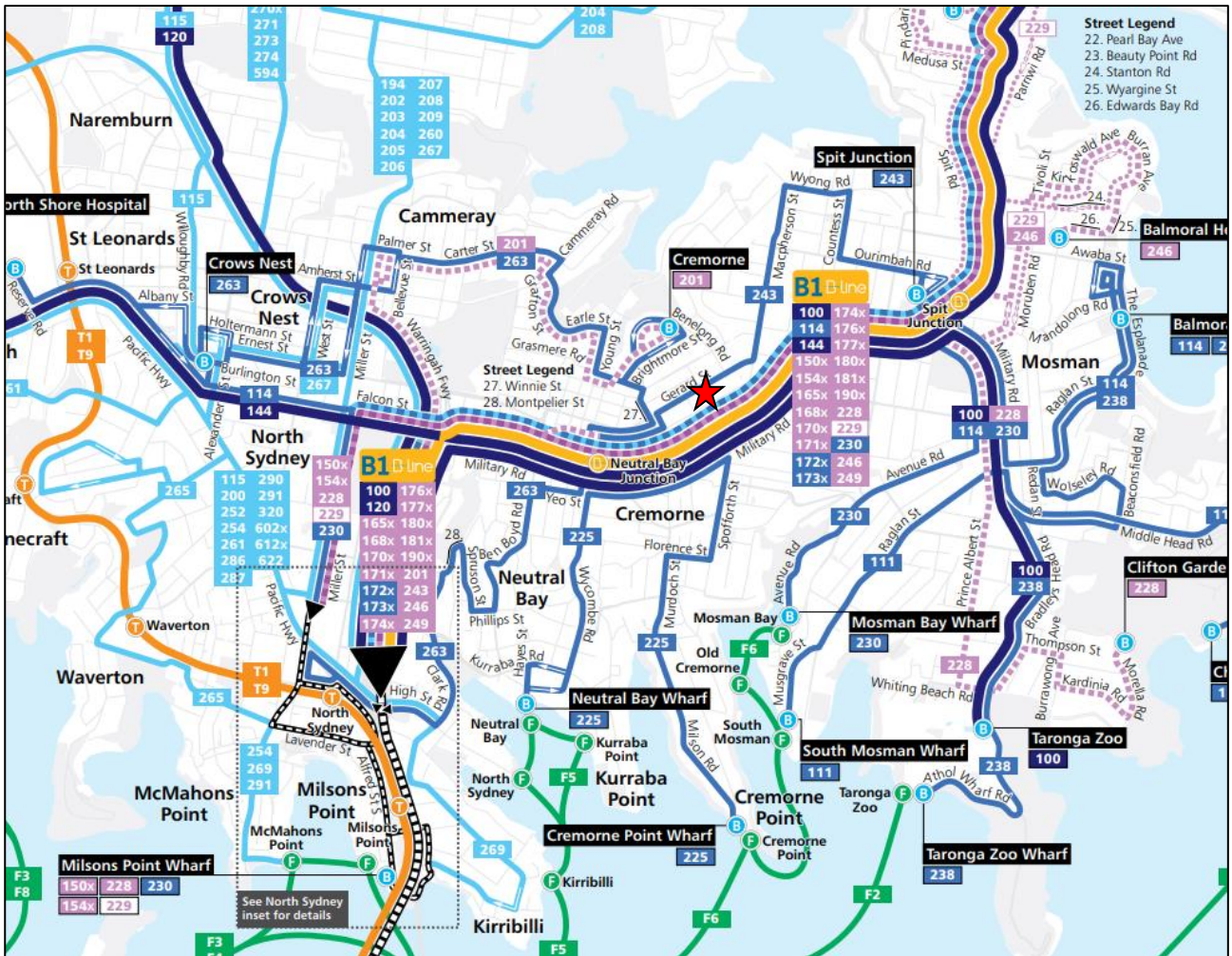

Site Location

FIGURE 3: PUBLIC TRANSPORT NETWORK MAP

3.5 Future Road and Infrastructure Upgrades

From North Sydney Council’s Development Application tracker and website, it appears that there are no future planned road or public transport changes that will affect traffic conditions within the immediate vicinity of the subject site.

4 PARKING ASSESSMENT

4.1 Council's DCP Parking Requirements

Reference is made to North Sydney Council's *North Sydney Development Control Plan (DCP) 2013, Section 10: Car Parking & Transport*, which does not outline any parking requirements for residential aged care facilities or independent living units.

It is noted that the North Sydney DCP does provide a maximum parking rate of Seniors Housing developments of 1 space per 5 dwellings, which correlates to the *State Environmental Planning Policy (SEPP) (Housing) 2021 (SEPP Housing)* for a development being undertaken by a social housing provider.

The subject development is not being undertaken by a social housing provider and therefore the recommended applicable minimum provisions of car parking for the subject ILU should be based upon the *SEPP Housing* non-discretionary requirements for developments not being undertaken by a social housing provider.

It should also be noted that the maximum car parking requirements within the NDCP that relate to residential flat buildings do not apply to the subject site.

4.2 State Environmental Planning Policy (Housing) 2021 Parking Requirements

Reference is made to the *State Environmental Planning Policy (Housing) 2021*, which outlines the following parking requirements for Independent Living Units and residential aged care facilities:

107 Non-discretionary development standards for hostels and residential care facilities

(2) The following are non-discretionary development standards in relation to the development for the purposes of hostels or residential care facilities

.....

(h) for a residential care facility – at least 1 parking space for every 15 beds in the facility

(i) at least 1 parking space for every 2 employees who are on duty at the same time,

(j) At least 1 parking space for the purpose of ambulance parking.

108 Non-discretionary development standards for independent living units

(k) if paragraph (j) does not apply – at least 0.5 parking spaces for each bedroom.

85 Development Standards for Hostels and Independent Living Units

(3) Development consent must not be granted for development for the purposes of a hostel or an independent living unit unless the hostel or

independent living unit complies with the relevant standards specified in Schedule 4.

Schedule 4

5. Private Car Accommodation

If car parking (not being car parking for employees) is provided

- (a) Car parking spaces must comply with the requirements for parking for persons with a disability set out in AS2890.6, and
- (b) 10% of the total number of car parking spaces (or at least one space if there are fewer than 10 spaces) must be designed to enable the width of the spaces to be increased to 3.8 metres, and
- (c) Any garage must have a power-operated door, or there must be a power point and an area for motor or control rods to enable a power-operated door to be installed at a later date.

Based upon the above, all parking for independent living units are to be designed in accordance with AS2890.6:2022 and the summary of the required parking rate for the development is outlined in **Table 3**:

TABLE 3: CAR PARKING REQUIREMENTS

Land Use	Scale	Rate	Parking Requirements
Independent Living Units	17 x 2 bedroom	1 space per unit	17
	40 x 3 bedroom	1.5 spaces per unit	60
	1 x 4 bedroom	2 spaces per unit	2
Residential Aged Care	41 Beds	1 space per 15 beds	3 (2.7)
	14 Staff	1 space per 2 staff	7
	N/A	1 Ambulance Space	1
Total	-	-	89 + 1 ambulance

As shown above, the proposed development requires the provision of 89 car parking spaces, allocated as 79 for the ILU's and 10 for the residential aged care facility. The proposed development allocates 10 residential aged care parking spaces and 124 non-individually garaged ILU parking spaces exceeding the SEPP Housing parking requirements.

Whilst the development exceeds the SEPP Housing parking requirements, it is anticipated that the surplus of 45 non-individually garaged car parking spaces being allocated to the ILU will be utilised for the purposes of providing accessible car parking when required.

4.2.1 Public Domain

As part of the redevelopment of the site, existing driveways will be removed to create restored kerbside parking along both Gerard Street and Parraween Street. The redevelopment of the site consists of the following lots:

- 59 – 61 Gerard Street – 18 Units (one driveway);
- 63 – 67 Gerard Street – 3 dwellings (no driveway);
- 50, 52, 56, 58, 60, 62, 64, 66, 68, 70, 72, 74, 76, 78, 80, 82, 86 & 88 Parraween Street – 18 dwellings (18 driveways);
- 54, 84 Parraween Street – 2 dwellings (no driveways).

Based upon the replacement of driveways along Gerard Street to kerbside car parking, it is anticipated that one (1) additional on-street car parking spaces will be provided to the public.

The existing on-street car parking provided along the frontage of the site is ten (10) linemarked car parking spaces of which seven (7) are provided as 90-degree parking and three (3) as kerbside parallel parking and approximately 13 motorcycle spaces.

Based upon the removal of driveways along Paraween Street, it is anticipated that **15** additional on-street car parking spaces (in parallel kerbside format) will be provided for the benefit of the general public, which consists of an additional 16 car parking spaces and a loss of one (1) space due to the proposed driveway. Further, this would provide approximately six (6) motorcycle (in parallel kerbside format), although additional motorcycle parking can be provided in lieu of some car parking spaces if preferred by Council.

As part of the development application / condition of consent, consultation should occur with Council for the preferred public domain outcome, be it additional landscape area / tree planting or additional kerbside parking. It is anticipated that any additional on-street kerbside parking will be provided consistent with the existing time restricted parking within close proximity to the site.

4.3 Accessible Parking

In accordance with the SEPP (Housing) 2021 design requirements, all parking associated with the independent living units are to be designed in accordance with AS2890.6:2022.

Further, the requirement for 10% of spaces to be widened to 3.8m is not required when considering that the AS2890.6:2022 design requirements exceed this by providing a 2.4m wide car parking space and a 2.4m wide shared space. If any independent living unit car parking spaces are enclosed, it is recommended that single car parking space garages are 3.8m in width to comply with AS4299:1995 requirements, that is permit a person with a wheelchair to get in and out of both the car and the parking space. Any double garages shall provide a minimum width of 6.2m.

Reference is made to North Sydney Council's *North Sydney Development Control Plan 2013, Section 10: Car Parking & Transport*, which outlines a rate of 1-2% of all non-residential parking spaces to be designed for use by the disabled. Hence, the residential aged care facility requires the provision of one (1) accessible space which has been provided.

4.4 Bicycle & Motorcycle Parking Requirements

4.4.1 Bicycle Parking Requirements

Reference is made to North Sydney Council's *North Sydney Development Control Plan 2013, Section 10: Car Parking & Transport*, which does not outline bicycle requirements for RACF or ILU.

Whilst this is the case, it is recommended to provide bicycle parking for the residential aged care staff to support alternative travel modes. In view of this, 14 bicycle spaces are recommended to be provided. The proposed development provides 56 bicycle spaces, a surplus of 42 above the recommended rate.

4.4.2 Motorcycle Parking Requirements

Council's DCP outlines the requirement for a minimum of one (1) motorcycle space per 10 cars or part thereof. Based upon this rate, the development would require 13 motorcycle spaces based upon the provision of 134 spaces. The proposed development provides nine (9) motorcycle parking spaces, resulting in a shortfall of four (4) spaces, although there is a surplus of 45 spaces, hence any motorcycle parking can be stored within the excess car parking spaces.

4.5 Servicing & Loading

Reference is made to North Sydney Council's *North Sydney Development Control Plan 2013, Section 10: Car Parking & Transport*, which outlines the following minimum off-street loading and unloading facility requirements for residential developments:

P2 Developments containing more than 30 dwellings but less than 60 must provide at least 1 service delivery space, capable of accommodating at least 1 Medium Rigid Vehicle.

P3 Developments containing more than 60 dwellings must provide at least 1 service delivery space, capable of accommodating at least:

1 Heavy Rigid Vehicle; or

2 Medium Rigid Vehicles.

Based upon the above, the residential aged care and independent living units of the site require the provision of a loading facility which can accommodate either one (1) heavy rigid vehicle or two (2) medium rigid vehicles. The proposed plans detail the provision of two (2) Medium Rigid Vehicle (MRV) parking spaces complying with this requirement.

It is relevant to note that the headroom for the Medium Rigid Vehicle within the basement is 3.8m, as such the largest MRV vehicle that may enter and exit the site shall be limited to a height of 3.6m in accordance AS2890.2:2018.

In addition to the above servicing requirements, the loading bays will be capable of providing ambulance parking. The largest ambulance within the NSW Fleet has the following design:

- 3.2m in height (including aerial);
- 2.6m width;
- 7.0m length.

Based upon the above, ambulance vehicles can operate within the provided headroom.

The anticipated use of the loading dock will be generally limited to the following:

- Waste collection – typically 1 to 2 times a week;
- Daily bread deliveries;
- Fresh food - fruit and vegetables once a week;
- Other suppliers likely to be 2-3 times a week.

4.6 Green Travel Plan

To promote sustainable travel choices by staff, residents and visitors of the development, a Green Travel Plan has been developed and is provided in **Annexure D**. The Green Travel Plan (GTP) has been prepared to support the Development Application for the proposed seniors living / aged care development and outlines:

- The alternative transport options available to staff of and visitors to the development;
- Suggested initiatives to increase the use of alternative transport modes, thereby reducing private car travel;
- Sustainable transport targets and milestones and methods to measure and report on transport behaviour over time.

4.7 Car Park Design & Compliance

The car parking layout as depicted in **Annexure A**, has been assessed to achieve the relevant clauses and objectives of AS2890.1:2004, AS2890.2:2018 and AS2890.6:2022. Swept path testing has been undertaken with results reproduced within **Annexure E** for reference.

The proposed car parking and vehicular access design achieves the following:

- 6.9m wide circulation roadway / ramp between kerbs and 7.5m between walls facilitating access to / from Parraween Street;
- Maximum ramp gradient of 15.4% for Medium Rigid Vehicle and changes in grades typically no greater than 6.25%;
- Minimum 7.0m transition at a maximum grade of 5% at the boundary;
- Minimum 5.4m long, 2.4m wide spaces for staff;
- Minimum 5.4m long, 2.5m wide spaces for visitors;
- Minimum 5.4m long, 2.4m wide accessible spaces with adjacent associated 5.4m long, 2.4m wide shared space;
- Minimum 1m width blind aisle extensions.

5 PEDESTRIAN MANAGEMENT

As part of the assessment, consideration has been made to the provision of pedestrian facilities across Parraween Street between Paling Street and Langley Avenue. This has been considered as developments on the southern side of Parraween Street are mixed use and it is important to ensure safe crossing locations are provided for elderly, as there can be greater difficult for elderly to cross busy roads unassisted.

Reference is made to the Transport for NSW (TfNSW) *Supplement to Australian Standard AS1742.10-2009, Manual of Uniform Traffic Control Devices – Part 10: Pedestrian control and protection Version 3.1*, which states the following warrants for the provision of zebra pedestrian crossings:

Transport practice for numerical warrants for Pedestrian (Zebra) Crossings on arterial roads are:

i) Normal Warrant:

A pedestrian (Zebra) Crossing is warranted where:

In each of three separate one hour periods in a typical day

(a) The pedestrian flow per hour (P) crossing the road is greater than or equal to 30

AND

a) The vehicular flow per hour (V) through the site is greater than or equal to 500

AND

b) The product PV is greater than or equal to 60,000

ii) Reduced Warrant for sites used predominantly by children and by aged or impaired pedestrians:...

If at least 50% of pedestrians using the crossing are aged or impaired and for each three one hour periods in a typical day

(a) $P \geq 30$

AND

(b) $V \geq 200$

AND

(c) $PV \geq 60,000$

a pedestrian (Zebra) Crossing may be installed.

As per the completed traffic intersection surveys (detailed in **Section 3.3**), the peak traffic volume surveyed to occur along Parraween Street at Winnie Street and Macpherson Street was 345 (AM Peak) and 260 (AM Peak) vehicles two-way vehicles respectively. These volumes are highly conservative estimates of the traffic volumes travelling along the site frontage of the development with Parraween Street, as the volumes would be less, as these two (2) intersections would collect all traffic entering and exiting Parraween Street between Winnie Street and Macpherson Street.

With added consideration that the proposed development is estimated to add some 19 vehicular trips to the road network during peak periods, this peak hourly volume is expected to increase to some 364 (AM Peak) and 277 (AM Peak) peak hourly vehicles. With consideration to the warrant assessment, there would be required to be a minimum of 165 pedestrian crossing any midblock pedestrian crossing, of which 50% (83) would need to be aged or impaired.

The following rates were considered to determine the person-based traffic generation trips:

- 43% of the PM peak commuter period (as per *RTA Trip Generation and Parking Generation Surveys – Section 3.6.3*);
- 0.258 network PM peak trips / unit (the average value of “Vehicle Network PM Peak Hour Trips / Unit” for Sydney Metropolitan Area within *Appendix C2 of RMS TDT 2013/04a*):
 - It should be noted that there is a typographical error within the table as this row is incorrectly labelled as “vehicle network” peak.
- 0.464 site peak hour trips / unit (the average value of “Site Peak Hour Trips / Unit” for Sydney Metropolitan Area within *Appendix C2 of RMS TDT 2013/04a*);

With consideration to person based traffic generation trips, the proposed development would generate the following pedestrians during the following time periods:

- AM Commuter Peak Hour – 7 person trips;
- PM Commuter Peak Hour – 15 person trips;
- Site Peak Hour – 27 person trips.

With consideration to the above, the need for a formal pedestrian crossing is not met and therefore, it is not recommended such a facility is installed. It should be noted that whilst a formal pedestrian crossing is not being recommended along the midblock of Parraween Street opposite the site, there are existing formal pedestrian crossing facilities at the intersection of Paling Street / Parraween Street and Parraween Street / Council car park that can be used as an alternative.

6 TRAFFIC ASSESSMENT

The impact of the expected traffic generation levels associated with the subject proposal is discussed in the following sub-sections.

6.1 Traffic Generation

Traffic generation rates for the relevant land uses are provided in the *RTA Guide to Traffic Generating Developments (2002)* (RTA Guide) as adopted by Transport for NSW (TfNSW) and recent supplements and are as follows:

RTA Guide / TDT Technical Direction

3.3.4 Housing for aged and disabled persons.

Evening peak hour vehicle trips = 0.1 - 0.2 per dwelling

3.3.3 High Density Residential

Peak Hour 0.24 vehicle trips per unit

Housing for Seniors (Hyder Analysis Report dated June 2009)

Sydney Metropolitan Area

Average PM network peak vehicle trips – 0.18 per dwelling

Average Site peak vehicle trips – 0.30 per dwelling.

Average AM network peak vehicle trips – 43% of site peak

Low Density Residential Dwelling

Sydney Metropolitan Area

Average AM network peak vehicle trips – 0.99 per dwelling

Average PM network peak vehicle trips – 0.95 per dwelling

Medium Density Residential Flat Building

Smaller Units

Average AM & PM network peak vehicle trips – 0.4-0.5 per dwelling

A summary of the estimated traffic generation of the site is outlined in **Table 4**

TABLE 4: ESTIMATED TRAFFIC GENERATION

Land Use	Scale	Rate	Traffic Generation	
			AM	PM
Residential Aged Care ⁽¹⁾	41 bedrooms	0.2 per dwelling	8	8
ILU (Senior)	58 units	0.13 per unit AM; 0.18 per unit PM	8	11
Total	-	-	16	19

Note: 1 – Assumed AM and PM peak are the same

As shown above the site is expected to generate some 16 vehicle trips in the AM peak hour period and 19 vehicle trips in the PM peak hour period. As part of any traffic assessment, the traffic generation of the existing uses should be considered within any impact assessment.

Section 4.2.1 details the existing development yield on the site which is summarised below for ease of reference:

- Residential Flat Building with 18 units;
- 18 single dwelling (18 driveways);
- 5 single dwellings (no driveways).

Based upon the above and discounting any developments that do not have on-site car parking, the existing sites would generate the following traffic as shown in **Table 5**:

TABLE 5: EXISTING ESTIMATED TRAFFIC GENERATION

Land Use	Scale	Rate	Traffic Generation	
			AM	PM
Medium Density	18 units	0.4 per dwelling	7	7
Low Density	18 dwellings	0.99 per unit AM; 0.95 per unit PM	18	17
Total	-	-	25	24

As shown above, the existing developments would generate 25 and 24 vehicle trips during the AM and PM peak hour periods respectively. When considering the proposed development, this is therefore a net reduction of nine (9) and five (5) vehicle trips during commuter periods.

Hence, it can be concluded that the proposed development will not have an adverse traffic impact on the road network as a result of the development.

Notwithstanding the above, performance of nearby intersection will be assessed on the basis that the site is a greenfield site.

6.2 Trip Assignment

The road network has been assessed and the following traffic assignment has been assumed for all traffic to and from the site:

- To the site:
 - 35% from Military Road (east of the site)
 - 15% from Gerard Street (west of the site)
 - 35% from Macpherson Street (north of the site);
 - 15% from Macpherson Street (south of the site).

From the site:

- 35% to Military Road (east of the site)
- 15% to Gerard Street (west of the site)
- 35% to Macpherson Street (north of the site);
- 15% to Macpherson Street (south of the site).

This traffic assignment is detailed in **Figure 4**.



Site Location

FIGURE 4: TRAFFIC ASSIGNMENT

6.3 Traffic Impact

The traffic generation outlined in **Section 6.1 & 6.2** above has been added to the existing traffic volumes recorded. SIDRA INTERSECTION 9.0 was used to assess the intersections performance. The purpose of this assessment is to compare the existing intersection operations to the future scenario under the increased traffic load. The results of this assessment are shown in Error! Reference source not found., with detailed SIDRA results provided in **Annexure C**.

TABLE 6: FUTURE INTERSECTION PERFORMANCES (SIDRA INTERSECTION 9.0)

Intersection	Peak Hour	Degree of Saturation ⁽¹⁾	Average Delay ⁽²⁾ (sec/veh)	Level of Service ⁽³⁾⁽⁴⁾	Control Type	Worst Movement
FUTURE PERFORMANCE						
Military Road / Winnie Street	AM	0.87	9.9	A	Signal	NA
	PM	0.89	16.6	B		NA
Macpherson Street / Paraween Street	AM	0.08	N/A (Worst: 5.4)	NA (Worst: A)	Give-Way	RT from Parraween Street
	PM	0.10	N/A (Worst: 6.0)	NA (Worst: A)		RT from Macpherson Street
Parraween Street / Winnie Street	AM	0.23	N/A (Worst: 6.0)	NA (Worst: A)	Give-Way	RT from Parraween Street
	PM	0.18	N/A (Worst: 5.9)	NA (Worst: A)		RT from Winnie Street (S)
Winnie Street / Gerard Street	AM	0.72	19.7	B	Signal	NA
	PM	0.68	16.5	B		NA

NOTES:

(1) The Degree of Saturation is the ratio of demand to capacity for the most disadvantaged movement.

(2) The average delay is the delay experienced on average by all vehicles. The value in brackets represents the delay to the most disadvantaged movement.

(3) The Level of Service is a qualitative measure of performance describing operational conditions. There are six levels of service, designated from A to F, with A representing the best operational condition and level of service F the worst. The LoS of the intersection is shown in bold, and the LoS of the most disadvantaged movement is shown in brackets.

(4) No overall Level of Service is provided for Give Way and Stop controlled intersections as the low delays associated with the dominant movements skew the average delay of the intersection. The Level of Service of the worst approach is an indicator of the operation of the intersection, with a worse Level of Service corresponding to long delays and reduced safety outcomes for that approach.

As shown, the assessed intersections, assuming the existing site is a greenfield retain the same worst movement Levels of Service under future conditions with minimal delays and additional spare capacity maintained, indicating that there will be no adverse traffic impact on the road network as a result of the proposed development.

It should be noted that there are no approved developments that are within close proximity to the site for the development to consider as part of cumulative traffic impact assessments. Further, the proposed development does not warrant a cumulative traffic impact assessment as the proposal reduces the traffic generation of the site.

7 CONSTRUCTION TRAFFIC MANAGEMENT PLAN

Typically, after the development application stage a detailed Construction Traffic Management Plan is provided at the construction certificate stage prior to construction and as part of a consent condition, to be approved by the relevant approving authority. Once a builder has been engaged, confirmation of the number of staff and construction vehicles can be provided and assessed (if required). Construction vehicular traffic is temporary in nature and is not expected to exceed the operating capacities of nearby intersections or be substantially greater than the assessed operation of the proposed development as detailed within this report.

Generally during construction, staff traffic will arrive to the site around 7:00am and depart the site around 5:00pm (or earlier), Monday to Saturday, with construction deliveries provided throughout the day. Considering the location and constraints of the site and surrounding environs, it is considered that some construction staff are likely to utilise the surrounding residential area / streets until such time as the proposed basement car parking area is available to utilise for staff car parking. The site manager is to promote the use of carpooling amongst staff and public transport usage to reduce the construction staff on-street car parking demand. It is highly unlikely that heavy construction traffic in conjunction with staff traffic will exceed the assessed 19 peak hour movements or the existing estimated traffic generation of the site being 25 vehicle trips.

Considering the location and constraint of the site and surrounding environs, it is considered that construction vehicle will be capable of entering and exiting the site in a forward direction during construction, especially demolition and excavation stages. During construction of the building, it is likely that a Works Zone will be required along the site frontages for construction deliveries, either from Gerard Street or Parraween Street. Once a builder is engaged, the methodology of the build will be detailed within a detailed Construction Traffic Management Plan (CTMP), to be approved by the relevant consent authority.

Suitable hoarding will need to be installed along pedestrian paths to maintain pedestrian routes or provide detours where necessary. During operation of any Works Zone, it is likely the TfNSW accredited Traffic Controllers will be required to monitor and assist pedestrians with appropriate access around the site.

Based upon the above methodology there will be no impact to existing public transport facilities, namely bus and train facilities. Temporary loss of parking would occur along Parraween Street due to the implementation of a Works Zone and there will be no major detours for pedestrians or cyclists.

In the event that a mobile crane / tower crane is required for the site, it is expected that this will be delivered to the site outside of peak operating hours of the surrounding road network such that it can be installed from either Gerard Street or Parraween Street. The delivery and approval of any mobile crane / tower crane is subject to a separate application to Council.

Clarification on construction vehicle movements, staff numbers and methodology will need to be confirmed with the builder during the submission of a detailed construction traffic management plan during the construction certificate stage as part of a consent condition as mentioned previously.

The haulage route for construction vehicles will be assessed within the detailed Construction Traffic Management Plan. It is likely that all construction vehicles using the site will utilize the arterial road of Military Road to access the site.

8 CONCLUSION

In view of the foregoing, the subject Proposed Seniors Housing Development proposal at 50 - 88 Parraween Street & 59-67 Gerard Street, Cremorne (as depicted in **Annexure A**) is fully supportable in terms of its traffic and parking impacts. The following outcomes of this traffic and parking impact assessment are relevant to note:

- a. The proposal requires the provision of **89** car parking spaces and one (1) ambulance space (79 IUL and 10 RACF), in accordance with the relevant controls applicable to the development, including the *SEPP (Housing) 2021*. The proposal provides 134 spaces, resulting in a surplus of 45 car parking spaces. It is anticipated that the surplus of car parking will be allocated to the ILU for the purposes of providing accessible car parking.
- b. Council's DCP does not require the provision of bicycle parking, but it is recommended that bicycle parking be provided for staff. This results in the recommended provision of 14 bicycle spaces. The proposal provides 56 bicycle spaces exceeding this requirement.
- c. Council's DCP outlines the requirement for a minimum of one (1) motorcycle space per 10 cars or part thereof. Based upon this rate, the development would require 13 motorcycle spaces based upon the provision of 134 spaces. The proposed development provides nine (**9**) motorcycle parking spaces, resulting in a shortfall of four (4) spaces, although there is a surplus of 45 spaces, hence any motorcycle parking can be stored within the excess car parking spaces.
- d. The proposed plans have been assessed against the relevant sections of *AS2890.1*, *AS2890.2* and *AS2890.6* and have been found to satisfy the objectives of each standard. Swept path testing has been provided and is reproduced in **Annexure E** for reference.
- e. All waste collection, deliveries and emergency services (ambulance) will utilise the loading area in the basement area accessed via the single lane loading driveway.
- f. The traffic generation of the proposed development has been estimated to be some **16** to **19** vehicle trips. The impacts of the traffic generation have been modelled using SIDRA INTERSECTION 9.0, indicating that there will be no detrimental impact to the performance of the intersections or on residential amenity surrounding the site as a result of the generated traffic.



**ANNEXURE A: PROPOSED PLANS
(2 SHEETS)**

UNIT TYPE
 ILU SHARED
 SHARED

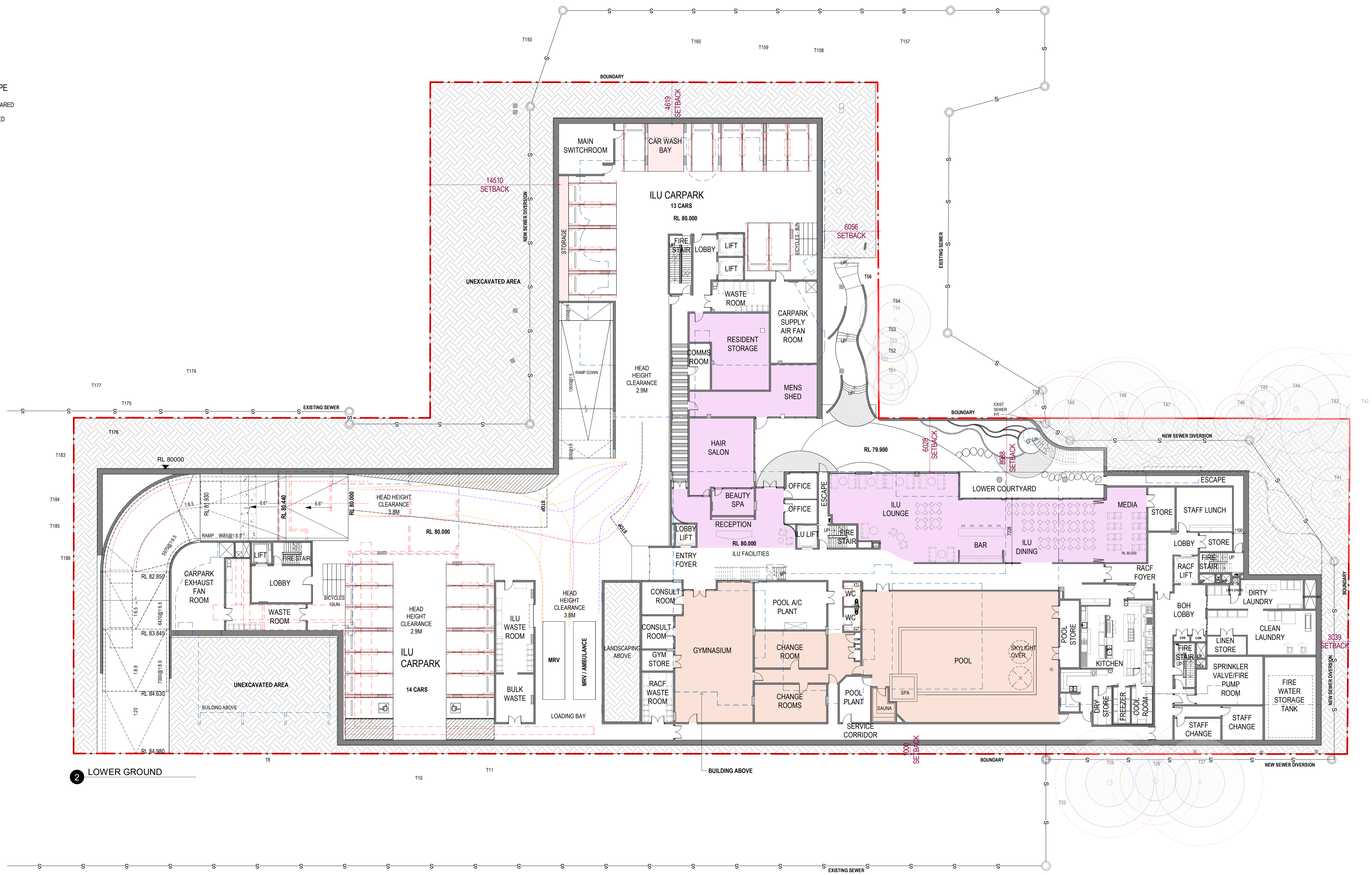

2 LOWER GROUND

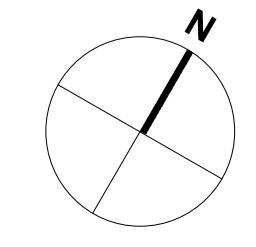

REV	DATE	AMENDMENT	INITIALS	CHECK
P01	2023-04-13	FOR INFORMATION	RE	RS
P02	2023-05-10	FOR COORDINATION	RE	RS
P03	2023-05-16	SDRP Additional Info	RAS	RAS
P04	2023-05-29	FOR COORDINATION	SC	RS
P05	2023-06-07	FOR COORDINATION	RE/REV	RS
P06	2023-06-09	PRELIM BASEMENT	LL	RS

PROJECT NO.	DRAWING NO.	REVISION
3236	DA10.02	P06
SCALE	1:200 @ A1	
DRAWN	LL	
NSW NOM ARB ARCH Reg:	Glen Oterton, Reg. No. 7621	
DATE	2023-06-09	

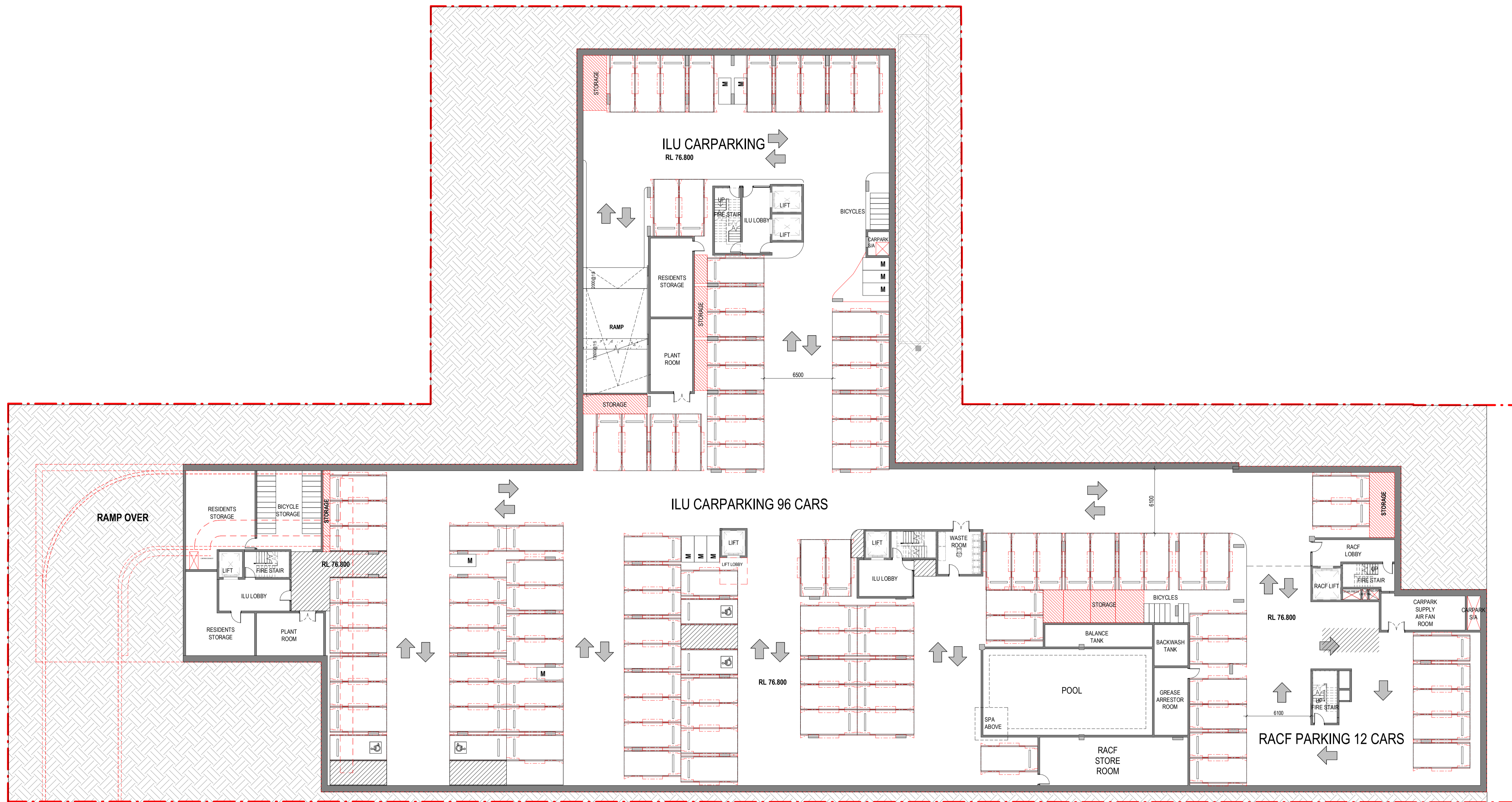

1 BASEMENT 02

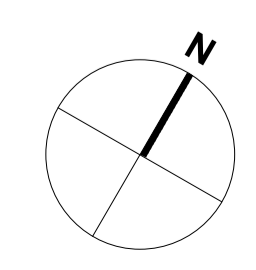

REV	DATE	AMENDMENT	INITIALS	CHECK
P01	2023-04-13	FOR INFORMATION	RE	RS
P02	2023-05-10	FOR COORDINATION	RE	RS
P03	2023-05-29	FOR COORDINATION	SC	RS
P04	2023-06-07	FOR COORDINATION	RE/EV	RS
P05	2023-06-09	PRELIM BASEMENT	LL	RS

PROJECT NO.	DRAWING NO.	REVISION
3236	DA10.01	P05
SCALE	1:200 @ A1	
DRAWN	LL	
NSW NDM ARB ARCH Reg:	Glen Orlerton, Reg. No. 7621	
DATE	2023-06-09	



**ANNEXURE B: TRAFFIC SURVEY DATA
(15 SHEETS)**

TRANS TRAFFIC SURVEY

TURNING MOVEMENT SURVEY

trafficsurvey.com.au



Intersection of Military Rd and Winnie St, Cremorne

GPS: -33.830254, 151.226513

Date:	Tue 26/07/22
Weather:	Overcast
Suburban:	Cremorne
Customer:	McLaren

North:	Winnie St
East:	Military Rd
South:	Murdoch St
West:	Military Rd

Survey	AM: 7:00 AM-9:30 AM
Period	PM: 2:30 PM-6:00 PM
Traffic	AM: 7:30 AM-8:30 AM
Peak	PM: 5:00 PM-6:00 PM

All Vehicles

Time		North Approach Winnie St				East Approach Military Rd				South Approach Murdoch St				West Approach Military Rd				Hourly Total	
Period Start	Period End	U	R	SB	L	U	R	WB	L	U	R	NB	L	U	R	EB	L	Hour	Peak
7:00	7:15	0	0	19	17	0	0	500	5	0	0	8	6	0	25	499	22	4567	
7:15	7:30	0	6	29	16	0	0	496	6	0	0	25	5	0	29	411	15	4675	
7:30	7:45	0	2	25	17	0	0	588	3	0	0	21	8	0	20	498	21	4796	Peak
7:45	8:00	0	2	38	21	0	0	554	7	0	0	38	5	0	29	510	21	4775	
8:00	8:15	0	2	45	13	0	0	581	18	0	0	37	14	0	23	458	18	4755	
8:15	8:30	0	1	51	17	0	0	549	12	0	0	53	9	0	27	434	6	4583	
8:30	8:45	0	3	30	18	0	0	582	3	0	1	32	5	0	25	470	13	4516	
8:45	9:00	0	0	29	31	0	0	585	6	0	0	37	4	0	16	475	22		
9:00	9:15	0	4	31	20	0	0	459	4	0	1	33	5	0	29	442	9		
9:15	9:30	0	2	23	18	0	0	529	4	0	0	39	9	0	22	431	15		
14:30	14:45	0	9	30	37	0	0	429	6	0	0	30	10	0	23	422	13	4310	
14:45	15:00	0	6	28	28	0	0	469	4	0	0	33	6	0	23	488	17	4376	
15:00	15:15	0	0	29	23	0	0	438	10	0	0	36	12	0	35	464	15	4393	
15:15	15:30	0	3	32	21	0	0	467	16	0	0	37	13	0	20	513	15	4414	
15:30	15:45	0	1	39	29	0	0	398	5	0	1	41	9	0	23	520	9	4408	
15:45	16:00	0	3	39	17	0	0	400	7	0	1	26	7	0	24	585	10	4471	
16:00	16:15	0	2	30	25	0	0	417	9	0	0	23	2	1	27	536	11	4421	
16:15	16:30	0	1	35	24	0	0	448	7	0	1	17	5	0	29	553	11	4528	
16:30	16:45	0	1	27	22	0	0	469	8	0	0	36	11	0	31	520	13	4552	
16:45	17:00	0	1	29	29	0	0	362	5	0	0	38	4	0	34	553	14	4575	
17:00	17:15	0	2	39	27	0	0	450	6	0	0	43	7	0	36	566	14	4676	Peak
17:15	17:30	0	7	32	23	0	0	412	7	0	0	33	5	0	27	595	14		
17:30	17:45	0	3	54	31	0	0	414	7	0	0	39	3	0	27	570	13		
17:45	18:00	0	3	35	22	0	0	436	7	0	0	37	7	0	28	579	16		

TRANS TRAFFIC SURVEY

TURNING MOVEMENT SURVEY

trafficsurvey.com.au



Intersection of Parraween St and Macpherson St, Cr

GPS -33.827213, 151.231004

Date:	Tue 26/07/22	North:	Macpherson St	Survey	AM: 7:00 AM-9:30 AM
Weather:	Overcast	East:	N/A	Period	PM: 2:30 PM-6:00 PM
Suburban:	Cremorne	South:	Macpherson St	Traffic	AM: 8:00 AM-9:00 AM
Customer:	McLaren	West:	Parraween St	Peak	PM: 2:45 PM-3:45 PM

All Vehicles

Time		North Approach Macpherson			South Approach Macpherson			West Approach Parraween St			Hourly Total	
Period Start	Period End	U	R	SB	U	NB	L	U	R	L	Hour	Peak
7:00	7:15	0	13	0	0	5	7	0	8	6	208	
7:15	7:30	2	18	2	0	6	11	0	4	3	242	
7:30	7:45	0	16	1	0	13	6	1	8	4	266	
7:45	8:00	2	23	0	0	15	18	0	11	5	311	
8:00	8:15	1	24	2	0	13	17	0	12	4	313	Peak
8:15	8:30	0	24	3	0	15	16	0	9	3	307	
8:30	8:45	1	29	5	0	20	18	0	17	4	284	
8:45	9:00	1	20	5	1	14	17	1	11	6		
9:00	9:15	0	20	5	0	16	17	0	9	0		
9:15	9:30	1	13	2	0	10	6	0	8	7		
14:30	14:45	1	13	4	0	18	10	0	14	4	310	
14:45	15:00	1	11	2	0	18	20	0	13	5	341	Peak
15:00	15:15	0	23	5	0	18	17	0	10	5	322	
15:15	15:30	0	23	2	0	18	35	0	10	10	316	
15:30	15:45	0	28	4	0	18	21	0	11	13	280	
15:45	16:00	0	15	6	0	11	12	0	2	5	246	
16:00	16:15	1	13	6	0	27	10	0	8	7	271	
16:15	16:30	0	12	3	0	19	15	0	12	1	275	
16:30	16:45	3	14	2	0	14	14	0	9	5	290	
16:45	17:00	0	10	1	0	27	18	0	9	11	302	
17:00	17:15	0	12	0	0	28	16	0	13	7	307	
17:15	17:30	2	21	2	0	24	14	0	10	4		
17:30	17:45	0	14	2	0	20	17	0	13	7		
17:45	18:00	0	15	3	0	19	20	0	17	7		

TRANS TRAFFIC SURVEY

TURNING MOVEMENT SURVEY

trafficsurvey.com.au



Intersection of Winnie St and Parraween St, Cremorne

GPS -33.829522, 151.226044

Date:	Tue 26/07/22	North:	Winnie St	Survey	AM: 7:00 AM-9:30 AM
Weather:	Overcast	East:	Parraween St	Period	PM: 2:30 PM-6:00 PM
Suburban:	Cremorne	South:	Winnie St	Traffic	AM: 8:00 AM-9:00 AM
Customer:	McLaren	West:	N/A	Peak	PM: 4:45 PM-5:45 PM

All Vehicles

Time		North Approach Winnie St			East Approach Parraween St			South Approach Winnie St			Hourly Total	
Period Start	Period End	U	SB	L	U	R	L	U	R	NB	Hour	Peak
7:00	7:15	1	32	10	0	18	6	0	9	19	494	
7:15	7:30	0	38	5	0	28	10	0	6	33	568	
7:30	7:45	2	37	12	0	21	10	0	11	32	623	
7:45	8:00	0	50	10	0	25	10	0	10	49	651	
8:00	8:15	0	54	14	0	32	14	0	16	39	666	Peak
8:15	8:30	0	54	10	0	40	14	0	9	48	622	
8:30	8:45	0	39	21	0	42	4	0	8	39	563	
8:45	9:00	1	49	16	0	33	10	1	12	47		
9:00	9:15	0	41	12	0	20	11	0	4	37		
9:15	9:30	0	32	11	0	13	7	3	8	42		
14:30	14:45	0	54	8	0	20	16	2	8	33	615	
14:45	15:00	1	52	18	0	20	10	0	14	36	640	
15:00	15:15	0	48	15	0	24	12	0	10	42	621	
15:15	15:30	0	46	22	0	37	16	0	12	39	594	
15:30	15:45	1	45	21	0	35	14	0	8	42	550	
15:45	16:00	0	44	17	0	18	17	0	7	29	513	
16:00	16:15	0	46	10	0	26	10	1	2	29	549	
16:15	16:30	1	47	15	0	23	12	0	10	20	584	
16:30	16:45	0	43	8	0	14	16	0	8	40	614	
16:45	17:00	0	47	27	0	28	13	0	13	40	673	Peak
17:00	17:15	0	47	20	0	22	13	0	11	46	669	
17:15	17:30	0	60	20	0	21	10	1	15	31		
17:30	17:45	0	64	24	0	33	13	2	13	39		
17:45	18:00	1	47	29	0	22	14	1	14	36		

TRANS TRAFFIC SURVEY

TURNING MOVEMENT SURVEY trafficsurvey.com.au



Intersection of Gerard St and Winnie St, Cremorne

GPS: -33.828779, 151.225553

Date:	Tue 26/07/22
Weather:	Overcast
Suburban:	Cremorne
Customer:	McLaren

North:	Winnie St
East:	Gerard St
South:	Winnie St
West:	Gerard St

Survey	AM: 7:00 AM-9:30 AM
Period	PM: 2:30 PM-6:00 PM
Traffic	AM: 8:00 AM-9:00 AM
Peak	PM: 5:00 PM-6:00 PM

All Vehicles

Time		North Approach Winnie St				East Approach Gerard St				South Approach Winnie St				West Approach Gerard St			Hourly Total	Peak	
Period Start	Period End	U	R	SB	L	U	R	WB	L	U	R	NB	L	U	R	EB	L	Hour	Peak
7:00	7:15	0	2	13	5	0	0	195	2	0	6	12	19	0	27	132	5	2143	
7:15	7:30	0	7	10	10	0	0	240	8	0	9	15	29	0	25	115	8	2408	
7:30	7:45	0	12	23	13	0	0	311	9	0	10	21	31	0	22	141	5	2672	
7:45	8:00	0	11	31	11	0	0	372	5	0	11	20	35	0	22	127	6	2829	
8:00	8:15	0	10	35	9	0	0	384	14	0	10	24	41	0	29	118	9	2852	Peak
8:15	8:30	0	10	29	23	0	0	426	9	0	13	29	40	0	24	126	11	2734	
8:30	8:45	0	4	21	27	0	0	436	12	0	17	29	33	0	24	144	8	2431	
8:45	9:00	0	4	23	29	0	0	372	14	0	26	30	31	0	29	112	4		
9:00	9:15	0	8	14	17	0	0	332	11	0	11	17	29	0	26	93	7		
9:15	9:30	0	4	10	11	0	0	229	10	0	7	21	28	0	26	86	5		
14:30	14:45	0	5	18	15	0	0	154	16	0	9	16	35	0	27	140	1	1892	
14:45	15:00	0	3	22	20	0	0	179	11	0	16	15	26	0	36	144	7	2039	
15:00	15:15	0	5	14	15	0	0	164	15	0	5	25	30	0	38	132	7	2065	
15:15	15:30	0	4	21	13	0	0	191	12	0	11	36	36	0	36	160	7	2102	
15:30	15:45	0	10	16	21	0	0	187	8	0	16	39	25	0	37	210	14	2114	
15:45	16:00	0	2	18	14	0	0	191	11	0	11	15	22	0	30	185	6	2033	
16:00	16:15	0	2	22	11	0	0	194	9	0	6	15	26	0	29	170	3	2108	
16:15	16:30	0	5	24	10	0	0	178	7	0	6	14	30	0	32	226	7	2265	
16:30	16:45	0	4	24	13	0	0	181	8	0	7	22	21	0	23	189	10	2349	
16:45	17:00	0	6	21	16	0	0	176	17	0	8	31	32	0	35	224	14	2490	
17:00	17:15	0	9	23	17	0	0	212	10	0	11	19	41	0	36	253	13	2510	Peak
17:15	17:30	0	8	26	21	0	0	168	22	0	6	22	28	0	38	277	7		
17:30	17:45	0	5	30	20	0	0	162	12	0	10	24	38	0	46	281	15		
17:45	18:00	0	2	22	7	0	0	140	17	0	9	19	22	0	40	311	11		

TRANS TRAFFIC SURVEY

TURNING MOVEMENT SURVEY

trafficsurvey.com.au



Intersection of Gerard St and Ada, Cremorne

GPS -33.827466, 151.228293

Date:	Tue 26/07/22	North:	Ada	Survey Period	AM: 7:00 AM-9:30 AM
Weather:	Overcast	East:	Gerard St	PM: 2:30 PM-6:00 PM	
Suburban:	Cremorne	South:	N/A	Traffic Peak	AM: 8:00 AM-9:00 AM
Customer:	McLaren	West:	Gerard St	PM: 5:00 PM-6:00 PM	

All Vehicles

Time		North Approach Ada			East Approach Gerard St			West Approach Gerard St			Hourly Total	
Period Star	Period End	U	R	L	U	R	WB	U	EB	L	Hour	Peak
7:00	7:15	0	0	1	0	0	207	0	138	1	1746	
7:15	7:30	0	1	1	0	2	241	0	135	2	1963	
7:30	7:45	0	0	1	0	0	312	0	156	6	2182	
7:45	8:00	0	1	5	0	0	385	0	150	1	2338	
8:00	8:15	0	0	3	0	0	426	0	130	5	2345	Peak
8:15	8:30	0	0	6	0	2	429	0	160	4	2243	
8:30	8:45	0	0	3	0	1	436	0	189	2	1986	
8:45	9:00	0	2	4	0	4	378	1	154	6		
9:00	9:15	0	0	3	0	1	333	0	121	4		
9:15	9:30	0	1	0	0	0	235	0	104	4		
14:30	14:45	0	0	0	0	2	174	0	163	3	1455	
14:45	15:00	0	0	1	0	3	184	0	183	3	1568	
15:00	15:15	0	3	1	0	0	195	0	153	3	1593	
15:15	15:30	0	0	4	0	1	202	0	175	2	1631	
15:30	15:45	0	1	3	0	2	196	0	249	4	1675	
15:45	16:00	0	0	3	0	3	190	0	200	3	1625	
16:00	16:15	0	1	1	0	1	204	0	184	2	1671	
16:15	16:30	0	1	2	0	0	179	0	241	5	1781	
16:30	16:45	0	0	2	0	1	189	0	213	0	1852	
16:45	17:00	0	0	1	0	0	195	0	248	1	1933	
17:00	17:15	0	0	2	0	1	224	0	268	8	1961	Peak
17:15	17:30	0	0	1	0	1	194	0	303	0		
17:30	17:45	0	0	1	0	1	170	1	303	10		
17:45	18:00	0	1	2	0	1	147	1	318	3		

TRANS TRAFFIC SURVEY

TURNING MOVEMENT SURVEY

trafficsurvey.com.au



Intersection of Military Rd and Winnie St, Cremorne

GPS: -33.830254, 151.226513

Date:	Wed 27/07/22
Weather:	Fine
Suburban:	Cremorne
Customer:	McLaren

North:	Winnie St
East:	Military Rd
South:	Murdoch St
West:	Military Rd

Survey	AM: 7:00 AM-9:30 AM
Period	PM: 2:30 PM-6:00 PM
Traffic	AM: 7:30 AM-8:30 AM
Peak	PM: 5:00 PM-6:00 PM

All Vehicles

Time		North Approach Winnie St				East Approach Military Rd				South Approach Murdoch St				West Approach Military Rd				Hourly Total	
Period Start	Period End	U	R	SB	L	U	R	WB	L	U	R	NB	L	U	R	EB	L	Hour	Peak
7:00	7:15	0	1	29	16	0	0	511	4	0	0	13	6	0	24	496	11	4702	
7:15	7:30	0	4	25	16	0	0	564	7	0	0	27	7	0	19	464	15	4786	
7:30	7:45	0	0	27	19	0	0	608	1	0	0	29	7	0	24	481	12	4870	Peak
7:45	8:00	0	5	34	18	0	0	624	6	0	0	24	7	0	21	479	17	4743	
8:00	8:15	0	3	55	18	0	0	572	14	0	1	47	15	0	36	418	16	4697	
8:15	8:30	0	2	47	20	0	0	573	6	0	0	43	7	0	23	504	7	4517	
8:30	8:45	0	1	20	25	0	0	493	2	0	0	36	4	0	29	463	8	4325	
8:45	9:00	0	1	32	18	0	0	592	7	0	0	28	6	0	20	473	12		
9:00	9:15	0	2	24	25	0	0	472	3	0	1	29	7	0	18	421	13		
9:15	9:30	0	1	29	25	0	0	468	7	0	0	31	8	0	23	435	13		
14:30	14:45	0	8	34	37	0	0	446	4	0	0	33	14	0	29	415	18	4300	
14:45	15:00	0	4	30	30	0	0	470	10	1	0	24	7	0	26	468	7	4318	
15:00	15:15	0	0	35	22	0	0	466	13	0	0	22	3	0	35	457	12	4357	
15:15	15:30	0	2	38	19	0	0	460	11	0	0	33	9	0	35	502	11	4380	
15:30	15:45	0	0	38	26	0	0	348	11	0	0	50	10	0	34	526	13	4409	
15:45	16:00	0	1	32	24	0	0	395	8	0	0	47	3	0	20	576	10	4500	
16:00	16:15	0	0	38	22	0	1	428	8	0	1	29	10	0	14	524	13	4491	
16:15	16:30	0	0	30	19	0	0	425	5	0	1	30	7	0	36	583	13	4598	
16:30	16:45	0	0	33	23	0	0	451	9	0	0	27	4	0	21	564	15	4568	
16:45	17:00	0	6	35	23	0	0	378	9	0	1	33	5	0	32	569	16	4665	
17:00	17:15	0	0	38	22	0	0	465	6	0	0	30	5	0	27	588	14	4729	Peak
17:15	17:30	0	6	21	25	0	0	390	8	0	0	37	2	0	38	580	12		
17:30	17:45	0	1	44	23	0	0	505	9	0	0	33	1	0	30	580	18		
17:45	18:00	0	5	39	34	0	0	417	9	0	0	36	5	0	31	580	15		

TRANS TRAFFIC SURVEY

TURNING MOVEMENT SURVEY

trafficsurvey.com.au



Intersection of Parraween St and Macpherson St, Cr

GPS -33.827213, 151.231004

Date:	Wed 27/07/22	North:	Macpherson St	Survey Period	AM: 7:00 AM-9:30 AM
Weather:	Fine	East:	N/A	PM: 2:30 PM-6:00 PM	
Suburban:	Cremorne	South:	Macpherson St	Traffic Peak	AM: 7:45 AM-8:45 AM
Customer:	McLaren	West:	Parraween St	PM: 3:00 PM-4:00 PM	

All Vehicles

Time		North Approach Macpherson			South Approach Macpherson			West Approach Parraween St			Hourly Total	
Period Start	Period End	U	R	SB	U	NB	L	U	R	L	Hour	Peak
7:00	7:15	1	15	1	0	6	10	0	3	2	237	
7:15	7:30	0	16	4	0	16	14	0	11	3	269	
7:30	7:45	2	24	1	0	9	11	0	8	10	291	
7:45	8:00	0	18	4	0	13	14	0	12	9	302	Peak
8:00	8:15	1	25	2	0	15	17	0	7	3	297	
8:15	8:30	0	19	2	1	15	20	0	19	10	275	
8:30	8:45	1	20	4	0	13	15	0	14	9	243	
8:45	9:00	1	17	3	0	15	15	0	12	2		
9:00	9:15	0	20	1	0	8	6	1	7	5		
9:15	9:30	2	17	4	0	7	11	0	9	4		
14:30	14:45	0	7	5	0	26	5	0	15	4	294	
14:45	15:00	0	8	7	0	21	15	0	6	8	313	
15:00	15:15	2	27	5	1	15	16	0	9	7	317	Peak
15:15	15:30	1	23	3	0	20	23	0	13	2	296	
15:30	15:45	0	21	3	1	20	14	0	16	6	293	
15:45	16:00	1	17	3	0	16	21	1	5	5	269	
16:00	16:15	1	12	5	0	19	12	0	6	6	265	
16:15	16:30	1	14	2	0	31	15	1	11	7	271	
16:30	16:45	2	15	1	0	15	13	0	9	2	258	
16:45	17:00	0	10	3	0	23	17	0	10	2	275	
17:00	17:15	0	17	1	1	17	14	0	10	7	287	
17:15	17:30	0	14	1	0	21	11	0	15	7		
17:30	17:45	2	9	2	0	25	18	1	11	6		
17:45	18:00	0	16	2	0	18	19	0	16	6		

TRANS TRAFFIC SURVEY

TURNING MOVEMENT SURVEY

trafficsurvey.com.au



Intersection of Winnie St and Parraween St, Cremorne

GPS -33.829522, 151.226044

Date:	Wed 27/07/22	North:	Winnie St	Survey	AM: 7:00 AM-9:30 AM
Weather:	Fine	East:	Parraween St	Period	PM: 2:30 PM-6:00 PM
Suburban:	Cremorne	South:	Winnie St	Traffic	AM: 7:45 AM-8:45 AM
Customer:	McLaren	West:	N/A	Peak	PM: 5:00 PM-6:00 PM

All Vehicles

Time		North Approach Winnie St			East Approach Parraween St			South Approach Winnie St			Hourly Total	
Period Start	Period End	U	SB	L	U	R	L	U	R	NB	Hour	Peak
7:00	7:15	0	39	8	0	15	10	0	5	17	501	
7:15	7:30	0	30	17	0	26	8	1	7	31	593	
7:30	7:45	1	38	20	0	21	10	1	8	33	665	
7:45	8:00	0	49	18	0	32	14	0	7	35	673	Peak
8:00	8:15	0	62	13	0	32	15	0	8	56	667	
8:15	8:30	0	59	24	0	49	8	1	9	42	615	
8:30	8:45	0	34	21	0	33	7	0	6	39	544	
8:45	9:00	0	43	20	0	33	12	0	5	36		
9:00	9:15	0	40	14	0	33	11	0	7	29		
9:15	9:30	0	38	12	0	15	8	0	8	40		
14:30	14:45	1	53	16	0	17	14	0	14	39	561	
14:45	15:00	1	52	16	0	20	8	0	3	27	585	
15:00	15:15	0	49	17	0	17	18	1	10	23	610	
15:15	15:30	1	45	13	0	31	11	0	11	33	607	
15:30	15:45	0	47	17	0	36	14	1	11	52	587	
15:45	16:00	0	42	11	0	26	13	2	11	47	550	
16:00	16:15	0	50	11	0	21	8	1	9	32	554	
16:15	16:30	0	35	16	0	19	10	2	8	35	570	
16:30	16:45	0	51	13	0	24	8	1	15	29	611	
16:45	17:00	0	52	17	0	23	15	1	12	36	632	
17:00	17:15	0	52	21	0	22	9	3	10	31	657	Peak
17:15	17:30	0	57	26	0	22	10	1	15	35		
17:30	17:45	0	53	27	0	19	13	0	20	30		
17:45	18:00	0	50	30	0	35	16	1	16	33		

TRANS TRAFFIC SURVEY

TURNING MOVEMENT SURVEY trafficsurvey.com.au



Intersection of Gerard St and Winnie St, Cremorne

GPS: -33.828779, 151.225553

Date:	Wed 27/07/22
Weather:	Fine
Suburban:	Cremorne
Customer:	McLaren

North:	Winnie St
East:	Gerard St
South:	Winnie St
West:	Gerard St

Survey	AM: 7:00 AM-9:30 AM
Period	PM: 2:30 PM-6:00 PM
Traffic	AM: 7:45 AM-8:45 AM
Peak	PM: 5:00 PM-6:00 PM

All Vehicles

Time		North Approach Winnie St				East Approach Gerard St				South Approach Winnie St				West Approach Gerard St				Hourly Total	
Period Start	Period End	U	R	SB	L	U	R	WB	L	U	R	NB	L	U	R	EB	L	Hour	Peak
7:00	7:15	0	4	20	7	0	0	208	4	0	5	13	17	0	25	122	2	2215	
7:15	7:30	0	8	16	10	0	0	293	9	0	9	14	34	0	25	129	5	2487	
7:30	7:45	0	9	32	12	0	0	307	7	0	11	15	33	0	19	156	6	2716	
7:45	8:00	0	7	34	22	0	0	331	8	0	11	19	37	0	28	123	9	2780	Peak
8:00	8:15	0	6	27	10	0	0	416	15	0	9	30	43	0	28	112	3	2749	
8:15	8:30	0	5	37	25	0	0	408	15	0	11	39	47	0	31	155	8	2544	
8:30	8:45	0	2	25	20	0	0	354	13	0	9	22	36	0	23	158	9	2187	
8:45	9:00	0	10	21	26	0	0	300	8	0	11	26	34	0	31	124	7		
9:00	9:15	0	8	16	14	0	0	242	15	0	11	22	34	0	24	102	6		
9:15	9:30	0	4	20	10	0	0	206	16	0	9	13	31	0	15	94	6		
14:30	14:45	0	6	28	13	0	0	167	16	0	11	14	33	0	21	132	10	1952	
14:45	15:00	0	3	19	16	0	0	196	17	0	8	17	24	0	34	140	7	2123	
15:00	15:15	0	4	24	15	0	0	212	14	0	2	21	19	0	28	127	2	2214	
15:15	15:30	0	6	20	10	0	0	217	11	0	6	20	35	0	28	188	11	2308	
15:30	15:45	0	5	25	25	0	0	200	16	0	11	35	44	0	27	226	8	2273	
15:45	16:00	0	3	18	16	0	0	212	10	0	8	27	35	0	23	208	12	2219	
16:00	16:15	0	4	21	20	0	0	215	10	0	8	23	29	0	31	194	7	2232	
16:15	16:30	0	6	18	9	0	0	202	10	0	10	26	16	0	25	185	10	2220	
16:30	16:45	0	8	26	11	0	1	183	11	0	5	23	25	0	30	236	9	2331	
16:45	17:00	0	12	27	10	0	0	182	11	0	10	23	26	0	31	236	17	2370	
17:00	17:15	0	7	21	16	0	0	164	8	0	7	27	19	0	44	226	11	2380	Peak
17:15	17:30	0	6	26	17	0	0	183	16	0	7	26	22	0	42	270	13		
17:30	17:45	0	8	25	18	0	0	168	12	0	9	23	20	0	44	264	16		
17:45	18:00	0	2	26	20	0	0	144	16	0	10	22	30	0	38	274	13		

TRANS TRAFFIC SURVEY

TURNING MOVEMENT SURVEY

trafficsurvey.com.au



Intersection of Gerard St and Ada, Cremorne

GPS -33.827466, 151.228293

Date:	Wed 27/07/22	North:	Ada	Survey Period	AM: 7:00 AM-9:30 AM
Weather:	Fine	East:	Gerard St	PM: 2:30 PM-6:00 PM	
Suburban:	Cremorne	South:	N/A	Traffic Peak	AM: 7:45 AM-8:45 AM
Customer:	McLaren	West:	Gerard St	PM: 5:00 PM-6:00 PM	

All Vehicles

Time		North Approach Ada			East Approach Gerard St			West Approach Gerard St			Hourly Total	
Period Star	Period End	U	R	L	U	R	WB	U	EB	L	Hour	Peak
7:00	7:15	0	0	3	0	1	238	0	134	0	1824	
7:15	7:30	0	0	0	0	0	289	0	147	3	1995	
7:30	7:45	0	0	0	0	0	320	0	175	3	2167	
7:45	8:00	0	0	2	0	1	350	0	157	1	2222	Peak
8:00	8:15	0	1	2	0	0	421	0	120	3	2189	
8:15	8:30	0	0	4	0	0	411	1	191	4	2019	
8:30	8:45	0	0	3	0	0	365	0	183	2	1738	
8:45	9:00	0	0	5	0	1	305	0	164	3		
9:00	9:15	0	0	1	0	0	254	0	119	3		
9:15	9:30	0	1	2	0	0	216	0	110	1		
14:30	14:45	0	0	4	0	5	196	0	148	2	1551	
14:45	15:00	0	1	0	0	3	226	0	166	0	1673	
15:00	15:15	0	0	3	0	2	215	0	151	2	1732	
15:15	15:30	0	0	3	0	2	225	0	195	2	1787	
15:30	15:45	0	0	2	0	0	215	0	255	5	1789	
15:45	16:00	0	0	1	0	3	216	0	230	5	1777	
16:00	16:15	0	0	1	0	2	212	1	206	6	1757	
16:15	16:30	0	1	4	0	0	212	0	209	3	1761	
16:30	16:45	0	0	2	0	1	204	0	252	6	1803	
16:45	17:00	0	0	3	0	0	184	0	246	2	1822	
17:00	17:15	0	0	3	0	2	178	0	248	1	1839	Peak
17:15	17:30	0	0	3	0	2	181	0	283	2		
17:30	17:45	0	0	0	0	2	182	0	296	4		
17:45	18:00	0	0	2	0	3	152	0	287	8		

TRANS TRAFFIC SURVEY

TURNING MOVEMENT SURVEY

trafficsurvey.com.au



Intersection of Military Rd and Winnie St, Cremorne

GPS: -33.830254, 151.226513

Date:	Thu 28/07/22
Weather:	Fine
Suburban:	Cremorne
Customer:	McLaren

North:	Winnie St
East:	Military Rd
South:	Murdoch St
West:	Military Rd

Survey	AM: 7:00 AM-9:30 AM
Period	PM: 2:30 PM-6:00 PM
Traffic	AM: 7:30 AM-8:30 AM
Peak	PM: 5:00 PM-6:00 PM

All Vehicles

Time		North Approach Winnie St				East Approach Military Rd				South Approach Murdoch St				West Approach Military Rd				Hourly Total	
Period Start	Period End	U	R	SB	L	U	R	WB	L	U	R	NB	L	U	R	EB	L	Hour	Peak
7:00	7:15	0	1	16	16	0	0	538	5	0	1	15	8	1	22	493	14	4681	
7:15	7:30	0	3	27	16	0	1	522	1	0	0	23	6	0	25	462	11	4686	
7:30	7:45	0	3	26	10	0	0	592	1	0	2	21	8	0	17	491	15	4693	Peak
7:45	8:00	0	4	32	20	0	1	645	8	0	0	46	7	0	24	458	23	4581	
8:00	8:15	0	2	45	14	0	0	569	20	0	0	43	8	0	25	394	15	4474	
8:15	8:30	0	2	46	16	0	0	543	4	0	0	33	10	0	28	415	7	4393	
8:30	8:45	0	3	32	26	0	0	534	4	0	0	58	4	0	31	375	7	4330	
8:45	9:00	0	1	25	22	0	0	558	4	0	1	33	4	0	18	477	18		
9:00	9:15	0	1	41	29	0	0	433	2	0	2	38	8	0	21	466	13		
9:15	9:30	0	1	38	23	0	0	431	5	0	0	32	5	0	23	466	17		
14:30	14:45	0	1	28	36	0	0	453	4	0	0	31	8	0	31	495	10	4460	
14:45	15:00	0	6	36	35	0	0	496	5	0	0	26	8	0	30	544	12	4497	
15:00	15:15	0	2	39	21	0	0	443	12	0	0	34	9	1	22	510	11	4466	
15:15	15:30	0	2	46	19	0	0	371	6	0	0	37	23	0	30	509	18	4434	
15:30	15:45	0	0	29	26	0	0	414	12	0	1	47	8	0	28	554	15	4416	
15:45	16:00	0	1	43	23	0	0	440	5	0	1	55	4	0	24	565	6	4369	
16:00	16:15	0	3	25	26	0	1	425	5	0	0	36	12	0	22	508	9	4313	
16:15	16:30	0	0	51	17	0	0	355	6	0	0	26	2	0	29	542	15	4409	
16:30	16:45	0	0	49	26	0	2	374	9	0	0	32	8	1	20	553	13	4599	
16:45	17:00	0	1	37	23	0	0	380	6	0	0	36	8	0	26	580	14	4639	
17:00	17:15	0	3	39	30	0	1	419	18	0	0	37	9	0	26	570	16	4698	Peak
17:15	17:30	0	4	31	26	0	1	491	12	0	0	27	4	0	24	598	15		
17:30	17:45	0	3	36	30	0	0	411	6	0	0	35	1	0	24	564	17		
17:45	18:00	0	5	39	21	0	1	426	4	0	0	32	4	0	26	592	20		

TRANS TRAFFIC SURVEY

TURNING MOVEMENT SURVEY

trafficsurvey.com.au



Intersection of Parraween St and Macpherson St, Cr

GPS -33.827213, 151.231004

Date:	Thu 28/07/22	North:	Macpherson St	Survey	AM: 7:00 AM-9:30 AM
Weather:	Fine	East:	N/A	Period	PM: 2:30 PM-6:00 PM
Suburban:	Cremorne	South:	Macpherson St	Traffic	AM: 8:00 AM-9:00 AM
Customer:	McLaren	West:	Parraween St	Peak	PM: 2:45 PM-3:45 PM

All Vehicles

Time		North Approach Macpherson			South Approach Macpherson			West Approach Parraween St			Hourly Total	
Period Start	Period End	U	R	SB	U	NB	L	U	R	L	Hour	Peak
7:00	7:15	0	12	0	0	4	7	0	3	4	200	
7:15	7:30	0	23	1	1	6	13	0	8	3	266	
7:30	7:45	0	16	1	0	8	6	2	6	5	287	
7:45	8:00	1	23	1	0	15	11	0	12	8	326	
8:00	8:15	2	27	6	0	14	27	0	16	4	330	Peak
8:15	8:30	0	33	0	1	7	16	0	15	4	310	
8:30	8:45	2	23	2	0	15	19	0	17	5	280	
8:45	9:00	0	21	6	1	16	11	0	12	8		
9:00	9:15	1	22	2	0	15	17	0	12	7		
9:15	9:30	1	11	2	0	12	8	0	7	5		
14:30	14:45	0	12	2	0	18	8	0	10	4	281	
14:45	15:00	2	20	9	0	19	10	0	9	8	324	Peak
15:00	15:15	2	19	7	0	14	12	0	6	5	313	
15:15	15:30	0	18	4	0	17	24	1	12	9	313	
15:30	15:45	1	27	4	0	18	23	0	17	7	308	
15:45	16:00	2	16	3	0	20	15	0	8	2	296	
16:00	16:15	0	21	2	0	16	13	0	8	5	285	
16:15	16:30	0	29	3	1	13	16	0	14	4	296	
16:30	16:45	1	16	2	0	20	18	0	21	7	287	
16:45	17:00	3	9	1	0	14	10	0	17	1	283	
17:00	17:15	1	16	3	1	22	15	1	12	5	303	
17:15	17:30	0	8	3	0	24	18	1	12	5		
17:30	17:45	0	18	2	0	19	23	1	13	5		
17:45	18:00	0	19	1	0	24	16	0	7	8		

TRANS TRAFFIC SURVEY

TURNING MOVEMENT SURVEY

trafficsurvey.com.au



Intersection of Winnie St and Parraween St, Cremorne

GPS -33.829522, 151.226044

Date:	Thu 28/07/22
Weather:	Fine
Suburban:	Cremorne
Customer:	McLaren

North:	Winnie St
East:	Parraween St
South:	Winnie St
West:	N/A

Survey Period	AM:	7:00 AM-9:30 AM
	PM:	2:30 PM-6:00 PM
Traffic Peak	AM:	7:45 AM-8:45 AM
	PM:	5:00 PM-6:00 PM

All Vehicles

Time		North Approach Winnie St			East Approach Parraween St			South Approach Winnie St			Hourly Total	
Period Start	Period End	U	SB	L	U	R	L	U	R	NB	Hour	Peak
7:00	7:15	0	28	10	0	12	3	0	9	19	485	
7:15	7:30	1	34	13	0	25	10	1	6	27	603	
7:30	7:45	1	36	11	0	29	3	0	8	27	675	
7:45	8:00	0	46	18	0	32	8	0	17	51	722	Peak
8:00	8:15	0	64	17	0	44	14	0	17	43	711	
8:15	8:30	0	52	20	1	62	14	0	6	34	680	
8:30	8:45	0	36	14	0	35	12	0	10	55	628	
8:45	9:00	0	45	26	0	32	7	0	15	36		
9:00	9:15	0	64	17	0	26	11	1	10	39		
9:15	9:30	0	41	14	0	21	13	1	13	34		
14:30	14:45	2	51	10	0	17	12	0	8	33	600	
14:45	15:00	0	66	12	0	20	12	1	8	28	625	
15:00	15:15	0	49	15	0	17	12	1	10	35	647	
15:15	15:30	1	54	18	0	37	16	0	19	36	662	
15:30	15:45	0	30	8	0	38	19	1	18	44	646	
15:45	16:00	0	44	18	0	26	17	3	13	48	662	
16:00	16:15	0	51	19	0	28	10	0	5	41	649	
16:15	16:30	0	62	21	0	27	14	0	8	33	674	
16:30	16:45	0	58	25	0	35	12	0	9	35	662	
16:45	17:00	0	48	29	0	17	12	0	12	38	654	
17:00	17:15	0	51	28	0	32	15	0	12	41	680	Peak
17:15	17:30	0	52	23	0	25	11	1	13	28		
17:30	17:45	0	43	31	0	27	17	1	16	31		
17:45	18:00	0	62	25	0	29	9	0	18	39		

TRANS TRAFFIC SURVEY

TURNING MOVEMENT SURVEY trafficsurvey.com.au



Intersection of Gerard St and Winnie St, Cremorne

GPS: -33.828779, 151.225553

Date:	Thu 28/07/22
Weather:	Fine
Suburban:	Cremorne
Customer:	McLaren

North:	Winnie St
East:	Gerard St
South:	Winnie St
West:	Gerard St

Survey	AM:	7:00 AM-9:30 AM
Period	PM:	2:30 PM-6:00 PM
Traffic	AM:	8:00 AM-9:00 AM
Peak	PM:	4:30 PM-5:30 PM

All Vehicles

Time		North Approach Winnie St				East Approach Gerard St				South Approach Winnie St				West Approach Gerard St				Hourly Total	
Period Start	Period End	U	R	SB	L	U	R	WB	L	U	R	NB	L	U	R	EB	L	Hour	Peak
7:00	7:15	0	6	10	11	0	0	175	2	0	4	15	13	0	25	130	5	2080	
7:15	7:30	0	5	19	13	0	0	252	12	0	5	21	22	0	20	131	4	2353	
7:30	7:45	0	4	23	13	0	0	329	8	0	6	26	27	0	17	107	3	2620	
7:45	8:00	0	8	30	11	0	0	337	13	0	14	25	41	0	21	113	4	2808	
8:00	8:15	0	9	40	17	0	0	342	13	0	10	26	50	0	36	118	8	2853	Peak
8:15	8:30	0	8	33	10	0	0	413	10	0	6	31	61	0	25	164	10	2743	
8:30	8:45	0	13	17	22	0	0	444	10	0	21	29	36	0	15	137	7	2429	
8:45	9:00	0	4	33	28	0	0	324	10	0	13	24	36	0	30	151	9		
9:00	9:15	0	6	28	17	0	0	279	17	0	9	26	26	0	39	105	7		
9:15	9:30	0	4	18	17	0	0	220	15	0	6	20	30	0	22	99	6		
14:30	14:45	0	3	24	27	0	0	180	18	0	6	16	26	0	22	151	7	2014	
14:45	15:00	0	4	38	23	0	0	187	16	0	6	19	29	0	24	162	5	2070	
15:00	15:15	0	1	15	14	0	0	201	19	0	3	18	23	0	32	161	5	2147	
15:15	15:30	0	2	22	9	0	0	198	13	0	12	21	42	0	37	169	4	2284	
15:30	15:45	0	2	12	11	0	0	218	4	0	13	33	41	0	25	173	4	2410	
15:45	16:00	0	4	25	19	0	0	209	8	0	9	22	43	0	32	209	10	2541	
16:00	16:15	0	8	30	17	0	0	221	12	0	8	19	44	0	30	234	6	2557	
16:15	16:30	0	6	23	17	0	0	208	17	0	7	26	30	0	41	271	9	2586	
16:30	16:45	0	2	25	10	0	0	221	12	0	10	27	30	0	45	275	10	2600	Peak
16:45	17:00	0	4	27	18	0	0	198	7	0	8	26	30	0	44	235	9	2548	
17:00	17:15	0	5	19	15	0	0	190	15	0	10	34	27	0	47	283	13	2582	
17:15	17:30	0	4	33	32	0	0	179	12	0	8	18	31	0	33	311	8		
17:30	17:45	0	6	22	16	0	0	157	18	0	6	18	33	0	35	291	13		
17:45	18:00	0	2	30	18	0	0	169	11	0	9	26	27	0	43	301	4		

TRANS TRAFFIC SURVEY

TURNING MOVEMENT SURVEY

trafficsurvey.com.au



Intersection of Gerard St and Ada, Cremorne

GPS -33.827466, 151.228293

Date:	Thu 28/07/22	North:	Ada	Survey Period	AM: 7:00 AM-9:30 AM
Weather:	Fine	East:	Gerard St	PM: 2:30 PM-6:00 PM	
Suburban:	Cremorne	South:	N/A	Traffic Peak	AM: 8:00 AM-9:00 AM
Customer:	McLaren	West:	Gerard St	PM: 4:30 PM-5:30 PM	

All Vehicles

Time		North Approach Ada			East Approach Gerard St			West Approach Gerard St			Hourly Total	
Period Star	Period End	U	R	L	U	R	WB	U	EB	L	Hour	Peak
7:00	7:15	0	0	0	0	0	175	0	145	3	1692	
7:15	7:30	0	0	1	0	3	276	0	145	0	1931	
7:30	7:45	0	0	2	0	1	329	0	119	1	2098	
7:45	8:00	0	0	3	0	1	345	0	137	6	2249	
8:00	8:15	0	0	3	0	0	408	0	147	4	2284	Peak
8:15	8:30	0	0	5	0	0	407	0	177	3	2147	
8:30	8:45	0	0	2	0	1	423	0	175	2	1915	
8:45	9:00	0	0	2	0	0	327	0	195	3		
9:00	9:15	0	0	1	0	2	290	0	128	4		
9:15	9:30	0	0	3	0	1	233	1	121	1		
14:30	14:45	0	0	3	0	5	196	0	182	2	1622	
14:45	15:00	0	1	4	0	3	211	2	193	6	1645	
15:00	15:15	0	1	1	0	1	226	0	178	2	1685	
15:15	15:30	0	0	0	0	2	220	0	182	1	1771	
15:30	15:45	0	0	0	0	0	211	0	197	3	1877	
15:45	16:00	0	0	1	0	2	220	0	234	3	1995	
16:00	16:15	0	0	2	0	2	227	0	263	1	2014	
16:15	16:30	0	1	0	0	4	219	0	282	5	2015	
16:30	16:45	0	1	4	0	2	228	0	289	5	2050	Peak
16:45	17:00	0	0	1	0	4	205	0	265	4	2014	
17:00	17:15	0	1	1	0	0	192	0	297	5	2023	
17:15	17:30	0	0	3	0	1	195	0	346	1		
17:30	17:45	0	0	4	0	0	175	0	310	4		
17:45	18:00	0	1	3	0	2	165	1	312	4		



**ANNEXURE C: SIDRA RESULTS
(18 SHEETS)**

MOVEMENT SUMMARY

Site: 101 [EX AM - Winnie Street / Military Road / Murdoch Street (Site Folder: Existing AM)]

Intersection of Military Road / Winnie Street / Murdoch Street

Existing Conditions

AM Peak Hour Period

Site Category: (None)

Signals - EQUISAT (Fixed-Time/SCATS) Coordinated Cycle Time = 140 seconds (Site User-Given Phase Times)

Vehicle Movement Performance														
Mov ID	Turn	INPUT VOLUMES		DEMAND FLOWS		Deg. Satn	Aver. Delay	Level of Service	95% BACK OF QUEUE		Prop. Que	Effective Stop Rate	Aver. No. Cycles	Aver. Speed
		[Total]	[HV]	[Total]	[HV]				[Veh.]	[Dist]				
		veh/h	veh/h	veh/h	%	v/c	sec		veh	m				km/h
South: Murdoch Street (S)														
1	L2	36	1	36	2.8	0.147	61.4	LOS E	2.2	15.9	0.92	0.72	0.92	24.0
2	T1	144	0	145	0.0	0.550	61.9	LOS E	9.5	66.2	0.98	0.79	0.98	18.5
Approach		180	1	182	0.6	0.550	61.8	LOS E	9.5	66.2	0.97	0.78	0.97	19.9
East: Military Road (E)														
4	L2	27	1	27	3.7	0.231	12.9	LOS A	5.0	60.7	0.42	0.40	0.42	41.7
5	T1	2377	218	2401	9.2	* 0.867	1.7	LOS A	10.0	71.1	0.16	0.16	0.16	39.6
Approach		2404	219	2428	9.1	0.867	1.9	LOS A	10.0	71.1	0.17	0.16	0.17	39.7
North: Winnie Street (N)														
7	L2	75	2	76	2.7	0.306	63.1	LOS E	4.7	34.0	0.94	0.76	0.94	18.3
8	T1	163	3	165	1.8	* 0.750	67.2	LOS E	12.1	89.6	1.00	0.89	1.10	17.7
9	R2	10	8	10	80.0	0.750	71.0	LOS F	12.1	89.6	1.00	0.89	1.10	17.7
Approach		248	13	251	5.2	0.750	66.1	LOS E	12.1	89.6	0.98	0.85	1.05	17.9
West: Military Road (W)														
10	L2	52	5	53	9.6	0.712	11.1	LOS A	33.2	251.4	0.53	0.51	0.53	34.8
11	T1	1882	177	1901	9.4	0.712	7.3	LOS A	33.2	251.4	0.50	0.48	0.50	37.0
12	R2	104	12	105	11.5	* 0.541	17.2	LOS B	5.9	45.3	1.00	0.89	1.00	33.9
Approach		2038	194	2059	9.5	0.712	7.9	LOS A	33.2	251.4	0.53	0.50	0.53	36.8
All Vehicles		4870	427	4919	8.8	0.867	9.9	LOS A	33.2	251.4	0.39	0.36	0.39	36.2

MOVEMENT SUMMARY

 Site: 101 [EX AM - Winnie Street / Gerard Street (Site Folder: Existing AM)]

Intersection of Winnie Street / Gerard Street

Existing Conditions

AM Peak Hour Period

Site Category: (None)

Signals - EQUISAT (Fixed-Time/SCATS) Isolated Cycle Time = 99 seconds (Site User-Given Phase Times)

Vehicle Movement Performance

Mov ID	Turn	INPUT VOLUMES		DEMAND FLOWS		Deg. Satn	Aver. Delay	Level of Service	95% BACK OF QUEUE		Prop. Que	Effective Stop Rate	Aver. No. Cycles	Aver. Speed
		[Total]	[HV]	[Total]	[HV]				[Veh.]	[Dist]				
		veh/h	veh/h	veh/h	%	v/c	sec		veh	m				km/h
South: Winnie Street (S)														
1	L2	183	0	193	0.0	0.577	40.2	LOS C	10.4	73.2	0.94	0.81	0.94	25.2
2	T1	110	2	116	1.8	0.577*	41.6	LOS C	10.4	73.2	0.96	0.80	0.97	22.0
3	R2	50	2	53	4.0	0.577	48.6	LOS D	5.7	41.1	0.98	0.80	0.99	16.7
Approach		343	4	361	1.2	0.577	41.9	LOS C	10.4	73.2	0.95	0.80	0.95	22.9
East: Gerard Street (E)														
4	L2	43	6	45	14.0	0.717	18.6	LOS B	27.7	196.9	0.76	0.71	0.76	27.2
5	T1	1523	17	1603	1.1	0.717*	15.0	LOS B	27.9	197.3	0.76	0.70	0.76	37.3
Approach		1566	23	1648	1.5	0.717	15.1	LOS B	27.9	197.3	0.76	0.70	0.76	37.1
North: Winnie Street (N)														
7	L2	77	1	81	1.3	0.453	44.1	LOS D	6.4	46.2	0.95	0.78	0.95	25.1
8	T1	123	6	129	4.9	0.453	42.3	LOS C	6.4	46.2	0.95	0.77	0.95	21.9
9	R2	34	0	36	0.0	0.453	47.2	LOS D	4.7	33.7	0.96	0.77	0.96	28.5
Approach		234	7	246	3.0	0.453	43.6	LOS D	6.4	46.2	0.95	0.77	0.95	24.2
West: Gerard Street (W)														
10	L2	34	2	36	5.9	0.542	10.8	LOS A	12.0	87.4	0.45	0.42	0.45	45.5
11	T1	570	24	600	4.2	0.542	7.2	LOS A	12.0	87.4	0.47	0.44	0.47	44.1
12	R2	106	1	112	0.9	0.542*	32.5	LOS C	6.2	44.0	0.95	0.83	0.95	28.0
Approach		710	27	747	3.8	0.542	11.2	LOS A	12.0	87.4	0.54	0.50	0.54	41.5
All Vehicles		2853	61	3003	2.1	0.717	19.7	LOS B	27.9	197.3	0.75	0.67	0.75	34.7

MOVEMENT SUMMARY

Site: 101 [EX AM - Parraween Street / Winnie Street (Site Folder: Existing AM)]

Intersection of Parraween Street / Winnie Street

Existing Conditions

AM Peak Hour Period

Site Category: (None)

Give-Way (Two-Way)

Vehicle Movement Performance

Mov ID	Turn	INPUT VOLUMES		DEMAND FLOWS		Deg. Satn	Aver. Delay	Level of Service	95% BACK OF QUEUE		Prop. Que	Effective Stop Rate	Aver. No. Cycles	Aver. Speed
		[Total veh/h]	[HV veh/h]	[Total veh/h]	[HV %]				[Veh. veh]	[Dist m]				
South: Winnie Street (S)														
2	T1	183	3	193	1.6	0.141	0.4	LOS A	0.4	3.0	0.20	0.11	0.20	36.1
3	R2	50	2	53	4.0	0.141	4.6	LOS A	0.4	3.0	0.20	0.11	0.20	38.8
Approach		233	5	245	2.1	0.141	1.3	NA	0.4	3.0	0.20	0.11	0.20	37.4
East: Parraween Street (E)														
4	L2	48	1	51	2.1	0.038	4.1	LOS A	0.1	1.1	0.30	0.48	0.30	37.0
6	R2	173	0	182	0.0	0.225	6.0	LOS A	0.8	5.6	0.48	0.71	0.48	35.7
Approach		221	1	233	0.5	0.225	5.6	LOS A	0.8	5.6	0.44	0.66	0.44	36.0
North: Winnie Street (N)														
7	L2	69	0	73	0.0	0.151	3.4	LOS A	0.0	0.0	0.00	0.12	0.00	39.5
8	T1	198	14	208	7.1	0.151	0.0	LOS A	0.0	0.0	0.00	0.12	0.00	37.5
Approach		267	14	281	5.2	0.151	0.9	NA	0.0	0.0	0.00	0.12	0.00	38.6
All Vehicles		721	20	759	2.8	0.225	2.5	NA	0.8	5.6	0.20	0.28	0.20	37.0

MOVEMENT SUMMARY

Site: 101 [EX AM - Gerard Street / Ada Street (Site Folder: Existing AM)]

Intersection of Gerard Street / Ada Street

Existing Conditions

AM Peak Hour Period

Site Category: (None)

Give-Way (Two-Way)

Vehicle Movement Performance														
Mov ID	Turn	INPUT VOLUMES		DEMAND FLOWS		Deg. Satn	Aver. Delay	Level of Service	95% BACK OF QUEUE		Prop. Que	Effective Stop Rate	Aver. No. Cycles	Aver. Speed
		[Total veh/h]	[HV veh/h]	[Total veh/h]	[HV %]				[Veh. veh]	[Dist m]				
East: Gerard Street (E)														
5	T1	1669	18	1757	1.1	0.454	0.2	LOS A	0.0	0.0	0.00	0.00	0.00	49.7
Approach		1669	18	1757	1.1	0.454	0.2	NA	0.0	0.0	0.00	0.00	0.00	49.7
North: Ada Street (N)														
7	L2	16	0	17	0.0	0.146	7.6	LOS A	0.4	2.7	0.85	0.91	0.85	35.6
9	R2	2	0	2	0.0	0.146	200.2	LOS F	0.4	2.7	0.85	0.91	0.85	32.6
Approach		18	0	19	0.0	0.146	29.0	LOS C	0.4	2.7	0.85	0.91	0.85	35.3
West: Gerard Street (W)														
10	L2	17	0	18	0.0	0.358	4.6	LOS A	0.0	0.0	0.00	0.01	0.00	49.1
11	T1	633	19	666	3.0	0.358	0.1	LOS A	0.0	0.0	0.00	0.01	0.00	49.7
Approach		650	19	684	2.9	0.358	0.2	NA	0.0	0.0	0.00	0.01	0.00	49.7
All Vehicles		2337	37	2460	1.6	0.454	0.4	NA	0.4	2.7	0.01	0.01	0.01	49.5

MOVEMENT SUMMARY

Site: 101 [EX AM - Parraween Street / Macpherson Street (Site Folder: Existing AM)]

Intersection of Parraween Street / Macpherson Street

Existing Conditions

AM Peak Hour Period

Site Category: (None)

Give-Way (Two-Way)

Vehicle Movement Performance

Mov ID	Turn	INPUT VOLUMES		DEMAND FLOWS		Deg. Satn	Aver. Delay	Level of Service	95% BACK OF QUEUE		Prop. Que	Effective Stop Rate	Aver. No. Cycles	Aver. Speed
		[Total veh/h]	[HV veh/h]	[Total veh/h]	[HV %]				[Veh. veh]	[Dist m]				
South: Macpherson Street (S)														
1	L2	73	1	77	1.4	0.071	4.6	LOS A	0.0	0.0	0.00	0.31	0.00	47.8
2	T1	52	2	55	3.8	0.071	0.0	LOS A	0.0	0.0	0.00	0.31	0.00	48.2
Approach		125	3	132	2.4	0.071	2.7	NA	0.0	0.0	0.00	0.31	0.00	47.9
North: Macpherson Street (N)														
8	T1	14	0	15	0.0	0.076	0.4	LOS A	0.4	2.5	0.25	0.47	0.25	46.8
9	R2	104	0	109	0.0	0.076	5.0	LOS A	0.4	2.5	0.25	0.47	0.25	46.0
Approach		118	0	124	0.0	0.076	4.4	NA	0.4	2.5	0.25	0.47	0.25	46.1
West: Parraween Street (W)														
10	L2	21	1	22	4.8	0.075	4.8	LOS A	0.3	1.9	0.19	0.55	0.19	46.2
12	R2	60	2	63	3.3	0.075	5.4	LOS A	0.3	1.9	0.19	0.55	0.19	45.8
Approach		81	3	85	3.7	0.075	5.3	LOS A	0.3	1.9	0.19	0.55	0.19	45.9
All Vehicles		324	6	341	1.9	0.076	4.0	NA	0.4	2.5	0.14	0.43	0.14	46.7

MOVEMENT SUMMARY

Site: 101 [FU AM - Winnie Street / Military Road / Murdoch Street (Site Folder: Future AM)]

Intersection of Military Road / Winnie Street / Murdoch Street

Future Conditions

AM Peak Hour Period

Site Category: (None)

Signals - EQUISAT (Fixed-Time/SCATS) Coordinated Cycle Time = 140 seconds (Site User-Given Phase Times)

Vehicle Movement Performance														
Mov ID	Turn	INPUT VOLUMES		DEMAND FLOWS		Deg. Satn	Aver. Delay	Level of Service	95% BACK OF QUEUE		Prop. Que	Effective Stop Rate	Aver. No. Cycles	Aver. Speed
		[Total veh/h]	[HV veh/h]	[Total veh/h]	[HV %]				[Veh. veh]	[Dist m]				
South: Murdoch Street (S)														
1	L2	36	1	36	2.8	0.147	61.4	LOS E	2.2	15.9	0.92	0.72	0.92	24.0
2	T1	144	0	145	0.0	0.550	61.9	LOS E	9.5	66.2	0.98	0.79	0.98	18.5
Approach		180	1	182	0.6	0.550	61.8	LOS E	9.5	66.2	0.97	0.78	0.97	19.9
East: Military Road (E)														
4	L2	27	1	27	3.7	0.231	12.9	LOS A	5.0	60.7	0.42	0.40	0.42	41.7
5	T1	2377	218	2401	9.2	* 0.867	1.7	LOS A	10.0	71.1	0.16	0.16	0.16	39.6
Approach		2404	219	2428	9.1	0.867	1.9	LOS A	10.0	71.1	0.17	0.16	0.17	39.7
North: Winnie Street (N)														
7	L2	75	2	76	2.7	0.306	63.1	LOS E	4.7	34.0	0.94	0.76	0.94	18.3
8	T1	163	3	165	1.8	* 0.761	67.7	LOS E	12.3	90.6	1.00	0.90	1.11	17.6
9	R2	11	8	11	72.7	0.761	71.5	LOS F	12.3	90.6	1.00	0.90	1.11	17.6
Approach		249	13	252	5.2	0.761	66.5	LOS E	12.3	90.6	0.98	0.86	1.06	17.8
West: Military Road (W)														
10	L2	53	5	54	9.4	0.712	11.1	LOS A	33.3	251.6	0.53	0.51	0.53	34.8
11	T1	1882	177	1901	9.4	0.712	7.3	LOS A	33.3	251.6	0.50	0.48	0.50	37.0
12	R2	104	12	105	11.5	* 0.541	17.2	LOS B	5.9	45.3	1.00	0.89	1.00	33.9
Approach		2039	194	2060	9.5	0.712	7.9	LOS A	33.3	251.6	0.53	0.50	0.53	36.8
All Vehicles		4872	427	4921	8.8	0.867	9.9	LOS A	33.3	251.6	0.39	0.36	0.39	36.2

MOVEMENT SUMMARY

 Site: 101 [FU AM - Winnie Street / Gerard Street (Site Folder: Future AM)]

Intersection of Winnie Street / Gerard Street

Future Conditions

AM Peak Hour Period

Site Category: (None)

Signals - EQUISAT (Fixed-Time/SCATS) Isolated Cycle Time = 99 seconds (Site User-Given Phase Times)

Vehicle Movement Performance

Mov ID	Turn	INPUT VOLUMES		DEMAND FLOWS		Deg. Satn	Aver. Delay	Level of Service	95% BACK OF QUEUE		Prop. Que	Effective Stop Rate	Aver. No. Cycles	Aver. Speed
		[Total veh/h]	[HV veh/h]	[Total veh/h]	[HV %]				[Veh. veh]	[Dist. m]				
South: Winnie Street (S)														
1	L2	186	0	196	0.0	0.582	40.2	LOS C	10.5	73.7	0.94	0.81	0.94	25.2
2	T1	110	2	116	1.8	0.582*	41.7	LOS C	10.5	73.7	0.96	0.80	0.97	22.0
3	R2	50	2	53	4.0	0.582	48.7	LOS D	5.8	41.7	0.98	0.80	0.99	16.7
Approach		346	4	364	1.2	0.582	41.9	LOS C	10.5	73.7	0.95	0.80	0.96	22.9
East: Gerard Street (E)														
4	L2	43	6	45	14.0	0.717	18.6	LOS B	27.7	196.9	0.76	0.71	0.76	27.2
5	T1	1523	17	1603	1.1	0.717*	15.0	LOS B	27.9	197.3	0.76	0.70	0.76	37.3
Approach		1566	23	1648	1.5	0.717	15.1	LOS B	27.9	197.3	0.76	0.70	0.76	37.1
North: Winnie Street (N)														
7	L2	77	1	81	1.3	0.454	44.1	LOS D	6.5	46.3	0.95	0.78	0.95	25.1
8	T1	123	6	129	4.9	0.454	42.3	LOS C	6.5	46.3	0.95	0.77	0.95	21.9
9	R2	34	0	36	0.0	0.454	47.2	LOS D	4.7	33.7	0.96	0.77	0.96	28.5
Approach		234	7	246	3.0	0.454	43.6	LOS D	6.5	46.3	0.95	0.77	0.95	24.2
West: Gerard Street (W)														
10	L2	34	2	36	5.9	0.547	10.8	LOS A	12.2	88.7	0.45	0.42	0.45	45.4
11	T1	570	24	600	4.2	0.547	7.0	LOS A	12.2	88.7	0.47	0.44	0.47	44.3
12	R2	109	1	115	0.9	0.547*	32.8	LOS C	6.1	43.5	0.95	0.84	0.95	27.8
Approach		713	27	751	3.8	0.547	11.2	LOS A	12.2	88.7	0.54	0.50	0.54	41.4
All Vehicles		2859	61	3009	2.1	0.717	19.7	LOS B	27.9	197.3	0.75	0.67	0.75	34.6

MOVEMENT SUMMARY

Site: 101 [FU AM - Parraween Street / Winnie Street (Site Folder: Future AM)]

Intersection of Parraween Street / Winnie Street

Future Conditions

AM Peak Hour Period

Site Category: (None)

Give-Way (Two-Way)

Vehicle Movement Performance

Mov ID	Turn	INPUT VOLUMES		DEMAND FLOWS		Deg. Satn	Aver. Delay	Level of Service	95% BACK OF QUEUE		Prop. Que	Effective Stop Rate	Aver. No. Cycles	Aver. Speed
		[Total veh/h]	[HV veh/h]	[Total veh/h]	[HV %]				[Veh. veh]	[Dist m]				
South: Winnie Street (S)														
2	T1	183	3	193	1.6	0.141	0.4	LOS A	0.4	3.1	0.20	0.11	0.20	36.0
3	R2	51	2	54	3.9	0.141	4.6	LOS A	0.4	3.1	0.20	0.11	0.20	38.8
Approach		234	5	246	2.1	0.141	1.3	NA	0.4	3.1	0.20	0.11	0.20	37.4
East: Parraween Street (E)														
4	L2	49	1	52	2.0	0.039	4.1	LOS A	0.2	1.1	0.30	0.48	0.30	37.0
6	R2	176	0	185	0.0	0.230	6.0	LOS A	0.8	5.7	0.48	0.71	0.48	35.7
Approach		225	1	237	0.4	0.230	5.6	LOS A	0.8	5.7	0.44	0.66	0.44	36.0
North: Winnie Street (N)														
7	L2	72	0	76	0.0	0.153	3.4	LOS A	0.0	0.0	0.00	0.12	0.00	39.5
8	T1	198	14	208	7.1	0.153	0.0	LOS A	0.0	0.0	0.00	0.12	0.00	37.5
Approach		270	14	284	5.2	0.153	0.9	NA	0.0	0.0	0.00	0.12	0.00	38.6
All Vehicles		729	20	767	2.7	0.230	2.5	NA	0.8	5.7	0.20	0.29	0.20	37.0

MOVEMENT SUMMARY

▽ Site: 101 [FU AM - Parraween Street / Macpherson Street (Site Folder: Future AM)]

Intersection of Parraween Street / Macpherson Street

Future Conditions

AM Peak Hour Period

Site Category: (None)

Give-Way (Two-Way)

Vehicle Movement Performance

Mov ID	Turn	INPUT VOLUMES		DEMAND FLOWS		Deg. Satn	Aver. Delay	Level of Service	95% BACK OF QUEUE		Prop. Que	Effective Stop Rate	Aver. No. Cycles	Aver. Speed
		[Total veh/h]	[HV veh/h]	[Total veh/h]	[HV %]				[Veh. veh]	[Dist m]				
South: Macpherson Street (S)														
1	L2	74	1	78	1.4	0.071	4.6	LOS A	0.0	0.0	0.00	0.32	0.00	47.7
2	T1	52	2	55	3.8	0.071	0.0	LOS A	0.0	0.0	0.00	0.32	0.00	48.2
Approach		126	3	133	2.4	0.071	2.7	NA	0.0	0.0	0.00	0.32	0.00	47.9
North: Macpherson Street (N)														
8	T1	14	0	15	0.0	0.078	0.4	LOS A	0.4	2.6	0.25	0.47	0.25	46.8
9	R2	107	0	113	0.0	0.078	5.0	LOS A	0.4	2.6	0.25	0.47	0.25	46.0
Approach		121	0	127	0.0	0.078	4.4	NA	0.4	2.6	0.25	0.47	0.25	46.1
West: Parraween Street (W)														
10	L2	24	1	25	4.2	0.078	4.8	LOS A	0.3	2.0	0.18	0.55	0.18	46.2
12	R2	61	2	64	3.3	0.078	5.4	LOS A	0.3	2.0	0.18	0.55	0.18	45.8
Approach		85	3	89	3.5	0.078	5.3	LOS A	0.3	2.0	0.18	0.55	0.18	45.9
All Vehicles		332	6	349	1.8	0.078	4.0	NA	0.4	2.6	0.14	0.43	0.14	46.7

MOVEMENT SUMMARY

 Site: 101 [EX PM - Winnie Street / Military Road / Murdoch Street (Site Folder: Existing PM)]

Intersection of Military Road / Winnie Street / Murdoch Street

Existing Conditions

PM Peak Hour Period

Site Category: (None)

Signals - EQUISAT (Fixed-Time/SCATS) Isolated Cycle Time = 140 seconds (Site User-Given Phase Times)

Vehicle Movement Performance

Mov ID	Turn	INPUT VOLUMES		DEMAND FLOWS		Deg. Satn	Aver. Delay	Level of Service	95% BACK OF QUEUE		Prop. Que	Effective Stop Rate	Aver. No. Cycles	Aver. Speed
		[Total	HV]	[Total	HV]				[Veh.	Dist]				
		veh/h	veh/h	veh/h	%	v/c	sec		veh	m				km/h
South: Murdoch Street (S)														
1	L2	18	0	19	0.0	0.100	62.0	LOS E	1.5	10.8	0.91	0.70	0.91	28.2
2	T1	131	2	138	1.5	0.501	61.3	LOS E	8.5	60.1	0.97	0.78	0.97	20.5
Approach		149	2	157	1.3	0.501	61.4	LOS E	8.5	60.1	0.96	0.77	0.96	21.6
East: Military Road (E)														
4	L2	40	1	42	2.5	0.209	14.1	LOS A	4.5	52.8	0.39	0.42	0.39	47.2
5	T1	1747	135	1839	7.7	0.635	12.5	LOS A	31.5	220.4	0.59	0.55	0.59	49.7
Approach		1787	136	1881	7.6	0.635	12.6	LOS A	31.5	220.4	0.58	0.55	0.58	49.6
North: Winnie Street (N)														
7	L2	107	2	113	1.9	0.453	65.7	LOS E	7.2	51.4	0.97	0.79	0.97	20.3
8	T1	145	1	153	0.7	* 0.752	67.5	LOS E	11.7	87.1	1.00	0.89	1.11	19.3
9	R2	15	10	16	66.7	0.752	72.2	LOS F	11.7	87.1	1.00	0.89	1.11	19.5
Approach		267	13	281	4.9	0.752	67.1	LOS E	11.7	87.1	0.99	0.85	1.05	19.7
West: Military Road (W)														
10	L2	68	6	72	8.8	0.889	16.9	LOS B	61.8	456.7	0.78	0.75	0.78	26.5
11	T1	2324	146	2446	6.3	* 0.889	10.8	LOS A	61.8	456.7	0.72	0.70	0.73	50.9
12	R2	100	1	105	1.0	0.451	19.8	LOS B	3.6	25.5	0.73	0.77	0.73	42.0
Approach		2492	153	2623	6.1	0.889	11.3	LOS A	61.8	456.7	0.73	0.70	0.73	49.7
All Vehicles		4695	304	4942	6.5	0.889	16.5	LOS B	61.8	456.7	0.69	0.65	0.70	46.0

MOVEMENT SUMMARY

Site: 101 [EX PM - Winnie Street / Gerard Street (Site Folder: Existing PM)]

Intersection of Winnie Street / Gerard Street

Existing Conditions

PM Peak Hour Period

Site Category: (None)

Signals - EQUISAT (Fixed-Time/SCATS) Isolated Cycle Time = 91 seconds (Site User-Given Phase Times)

Vehicle Movement Performance

Mov ID	Turn	INPUT VOLUMES		DEMAND FLOWS		Deg. Satn	Aver. Delay	Level of Service	95% BACK OF QUEUE		Prop. Que	Effective Stop Rate	Aver. No. Cycles	Aver. Speed
		[Total veh/h	HV] veh/h	[Total veh/h	HV] %				[Veh. veh	Dist] m				
South: Winnie Street (S)														
1	L2	118	2	124	1.7	0.435	38.5	LOS C	6.7	47.9	0.91	0.78	0.91	26.5
2	T1	105	3	111	2.9	0.435*	37.4	LOS C	6.7	47.9	0.94	0.77	0.94	25.9
3	R2	36	2	38	5.6	0.435	44.7	LOS D	4.3	30.9	0.96	0.76	0.96	19.1
Approach		259	7	273	2.7	0.435	38.9	LOS C	6.7	47.9	0.93	0.77	0.93	25.3
East: Gerard Street (E)														
4	L2	46	3	48	6.5	0.228	14.9	LOS B	5.3	38.3	0.52	0.50	0.52	33.5
5	T1	788	13	829	1.6	0.652*	12.7	LOS A	17.7	125.5	0.65	0.59	0.65	40.9
Approach		834	16	878	1.9	0.652	12.8	LOS A	17.7	125.5	0.64	0.58	0.64	40.6
North: Winnie Street (N)														
7	L2	75	3	79	4.0	0.355	42.0	LOS C	4.4	31.4	0.93	0.76	0.93	28.9
8	T1	104	1	109	1.0	0.355	37.6	LOS C	4.4	31.4	0.93	0.75	0.93	26.1
9	R2	15	2	16	13.3	0.355	42.4	LOS C	3.9	28.3	0.93	0.74	0.93	32.5
Approach		194	6	204	3.1	0.355	39.6	LOS C	4.4	31.4	0.93	0.75	0.93	27.9
West: Gerard Street (W)														
10	L2	40	0	42	0.0	0.679	11.8	LOS A	22.6	159.4	0.59	0.55	0.59	45.0
11	T1	1104	9	1162	0.8	0.679	9.3	LOS A	22.6	159.4	0.65	0.61	0.65	42.6
12	R2	169	2	178	1.2	0.679*	21.4	LOS B	14.7	104.0	0.87	0.79	0.87	33.7
Approach		1313	11	1382	0.8	0.679	10.9	LOS A	22.6	159.4	0.67	0.63	0.67	41.6
All Vehicles		2600	40	2737	1.5	0.679	16.4	LOS B	22.6	159.4	0.71	0.64	0.71	38.2

MOVEMENT SUMMARY

▽ Site: 101 [EX PM - Parraween Street / Winnie Street (Site Folder: Existing PM)]

Intersection of Parraween Street / Winnie Street

Existing Conditions

PM Peak Hour Period

Site Category: (None)

Give-Way (Two-Way)

Vehicle Movement Performance

Mov ID	Turn	INPUT VOLUMES		DEMAND FLOWS		Deg. Satn	Aver. Delay	Level of Service	95% BACK OF QUEUE		Prop. Que	Effective Stop Rate	Aver. No. Cycles	Aver. Speed
		[Total veh/h]	[HV veh/h]	[Total veh/h]	[HV %]				[Veh. veh]	[Dist m]				
South: Winnie Street (S)														
2	T1	139	9	146	6.5	0.128	0.6	LOS A	0.5	3.5	0.28	0.18	0.28	40.6
3	R2	61	0	64	0.0	0.128	5.9	LOS A	0.5	3.5	0.28	0.18	0.28	39.2
Approach		200	9	211	4.5	0.128	2.2	NA	0.5	3.5	0.28	0.18	0.28	39.7
East: Parraween Street (E)														
4	L2	52	0	55	0.0	0.041	4.1	LOS A	0.2	1.1	0.30	0.48	0.30	36.5
6	R2	113	0	119	0.0	0.147	5.8	LOS A	0.5	3.5	0.46	0.68	0.46	36.0
Approach		165	0	174	0.0	0.147	5.3	LOS A	0.5	3.5	0.41	0.62	0.41	36.2
North: Winnie Street (N)														
7	L2	107	1	113	0.9	0.177	4.6	LOS A	0.0	0.0	0.00	0.18	0.00	47.4
8	T1	208	11	219	5.3	0.177	0.0	LOS A	0.0	0.0	0.00	0.18	0.00	43.8
Approach		315	12	332	3.8	0.177	1.6	NA	0.0	0.0	0.00	0.18	0.00	46.1
All Vehicles		680	21	716	3.1	0.177	2.7	NA	0.5	3.5	0.18	0.29	0.18	40.3

MOVEMENT SUMMARY

Site: 101 [EX PM - Gerard Street / Ada Street (Site Folder: Existing PM)]

Intersection of Gerard Street / Ada Street

Existing Conditions

PM Peak Hour Period

Site Category: (None)

Give-Way (Two-Way)

Vehicle Movement Performance

Mov ID	Turn	INPUT VOLUMES		DEMAND FLOWS		Deg. Satn	Aver. Delay	Level of Service	95% BACK OF QUEUE		Prop. Que	Effective Stop Rate	Aver. No. Cycles	Aver. Speed
		[Total veh/h	HV] veh/h	[Total veh/h	HV] %				[Veh. veh	Dist] m				
East: Gerard Street (E)														
5	T1	820	15	863	1.8	0.448	0.2	LOS A	0.0	0.0	0.00	0.00	0.00	49.7
Approach		820	15	863	1.8	0.448	0.2	NA	0.0	0.0	0.00	0.00	0.00	49.7
North: Ada Street (N)														
7	L2	9	0	9	0.0	0.073	7.1	LOS A	0.2	1.4	0.81	0.83	0.81	37.1
9	R2	2	0	2	0.0	0.073	103.5	LOS F	0.2	1.4	0.81	0.83	0.81	34.4
Approach		11	0	12	0.0	0.073	24.6	LOS B	0.2	1.4	0.81	0.83	0.81	36.7
West: Gerard Street (W)														
10	L2	15	0	16	0.0	0.330	4.6	LOS A	0.0	0.0	0.00	0.01	0.00	49.1
11	T1	1197	14	1260	1.2	0.330	0.1	LOS A	0.0	0.0	0.00	0.01	0.00	49.8
Approach		1212	14	1276	1.2	0.330	0.1	NA	0.0	0.0	0.00	0.01	0.00	49.8
All Vehicles		2043	29	2151	1.4	0.448	0.3	NA	0.2	1.4	0.00	0.01	0.00	49.6

MOVEMENT SUMMARY

Site: 101 [EX PM - Parraween Street / Macpherson Street (Site Folder: Existing PM)]

Intersection of Parraween Street / Macpherson Street

Existing Conditions

PM Peak Hour Period

Site Category: (None)

Give-Way (Two-Way)

Vehicle Movement Performance

Mov ID	Turn	INPUT VOLUMES		DEMAND FLOWS		Deg. Satn	Aver. Delay	Level of Service	95% BACK OF QUEUE		Prop. Que	Effective Stop Rate	Aver. No. Cycles	Aver. Speed
		[Total veh/h]	[HV veh/h]	[Total veh/h]	[HV %]				[Veh. veh]	[Dist m]				
South: Macpherson Street (S)														
1	L2	93	0	98	0.0	0.092	4.6	LOS A	0.0	0.0	0.00	0.30	0.00	47.8
2	T1	72	0	76	0.0	0.092	0.0	LOS A	0.0	0.0	0.00	0.30	0.00	48.3
Approach		165	0	174	0.0	0.092	2.6	NA	0.0	0.0	0.00	0.30	0.00	48.0
North: Macpherson Street (N)														
8	T1	13	1	14	7.7	0.066	0.5	LOS A	0.3	2.2	0.28	0.50	0.28	54.7
9	R2	86	0	91	0.0	0.066	6.0	LOS A	0.3	2.2	0.28	0.50	0.28	44.3
Approach		99	1	104	1.0	0.066	5.3	NA	0.3	2.2	0.28	0.50	0.28	45.5
West: Parraween Street (W)														
10	L2	34	0	36	0.0	0.067	3.6	LOS A	0.2	1.7	0.19	0.48	0.19	44.4
12	R2	44	0	46	0.0	0.067	4.4	LOS A	0.2	1.7	0.19	0.48	0.19	44.0
Approach		78	0	82	0.0	0.067	4.0	LOS A	0.2	1.7	0.19	0.48	0.19	44.2
All Vehicles		342	1	360	0.3	0.092	3.7	NA	0.3	2.2	0.13	0.40	0.13	46.3

MOVEMENT SUMMARY

Site: 101 [FU PM - Winnie Street / Military Road / Murdoch Street (Site Folder: Future PM)]

Intersection of Military Road / Winnie Street / Murdoch Street

Future Conditions

PM Peak Hour Period

Site Category: (None)

Signals - EQUISAT (Fixed-Time/SCATS) Isolated Cycle Time = 140 seconds (Site User-Given Phase Times)

Vehicle Movement Performance

Mov ID	Turn	INPUT VOLUMES		DEMAND FLOWS		Deg. Satn	Aver. Delay	Level of Service	95% BACK OF QUEUE		Prop. Que	Effective Stop Rate	Aver. No. Cycles	Aver. Speed
		[Total veh/h]	[HV veh/h]	[Total veh/h]	[HV %]				[Veh. veh]	[Dist m]				
South: Murdoch Street (S)														
1	L2	18	0	19	0.0	0.100	62.0	LOS E	1.5	10.8	0.91	0.70	0.91	28.2
2	T1	131	2	138	1.5	0.501	61.3	LOS E	8.5	60.1	0.97	0.78	0.97	20.5
Approach		149	2	157	1.3	0.501	61.4	LOS E	8.5	60.1	0.96	0.77	0.96	21.6
East: Military Road (E)														
4	L2	40	1	42	2.5	0.209	14.1	LOS A	4.5	52.8	0.39	0.42	0.39	47.2
5	T1	1747	135	1839	7.7	0.635	12.5	LOS A	31.5	220.4	0.59	0.55	0.59	49.7
Approach		1787	136	1881	7.6	0.635	12.6	LOS A	31.5	220.4	0.58	0.55	0.58	49.6
North: Winnie Street (N)														
7	L2	107	2	113	1.9	0.453	65.7	LOS E	7.2	51.4	0.97	0.79	0.97	20.3
8	T1	145	1	153	0.7	* 0.774	68.5	LOS E	12.0	89.1	1.00	0.91	1.14	19.2
9	R2	17	10	18	58.8	0.774	73.2	LOS F	12.0	89.1	1.00	0.91	1.14	19.4
Approach		269	13	283	4.8	0.774	67.7	LOS E	12.0	89.1	0.99	0.86	1.07	19.6
West: Military Road (W)														
10	L2	70	6	74	8.6	0.890	16.9	LOS B	62.0	457.9	0.78	0.75	0.78	26.5
11	T1	2324	146	2446	6.3	* 0.890	10.8	LOS A	62.0	457.9	0.73	0.70	0.73	50.8
12	R2	100	1	105	1.0	0.451	19.8	LOS B	3.6	25.5	0.73	0.77	0.73	42.0
Approach		2494	153	2625	6.1	0.890	11.4	LOS A	62.0	457.9	0.73	0.70	0.73	49.6
All Vehicles		4699	304	4946	6.5	0.890	16.6	LOS B	62.0	457.9	0.70	0.65	0.70	45.9

MOVEMENT SUMMARY

 Site: 101 [FU PM - Winnie Street / Gerard Street (Site Folder: Future PM)]

Intersection of Winnie Street / Gerard Street

Future Conditions

PM Peak Hour Period

Site Category: (None)

Signals - EQUISAT (Fixed-Time/SCATS) Isolated Cycle Time = 91 seconds (Site User-Given Phase Times)

Vehicle Movement Performance

Mov ID	Turn	INPUT VOLUMES		DEMAND FLOWS		Deg. Satn	Aver. Delay	Level of Service	95% BACK OF QUEUE		Prop. Que	Effective Stop Rate	Aver. No. Cycles	Aver. Speed
		[Total veh/h	HV veh/h	[Total veh/h	HV %				[Veh. veh	Dist] m				
South: Winnie Street (S)														
1	L2	121	2	127	1.7	0.438	38.5	LOS C	6.8	48.6	0.91	0.78	0.91	26.5
2	T1	105	3	111	2.9	0.438*	37.4	LOS C	6.8	48.6	0.94	0.77	0.94	25.8
3	R2	36	2	38	5.6	0.438	44.7	LOS D	4.3	31.2	0.96	0.77	0.96	19.1
Approach		262	7	276	2.7	0.438	38.9	LOS C	6.8	48.6	0.93	0.78	0.93	25.3
East: Gerard Street (E)														
4	L2	46	3	48	6.5	0.228	14.9	LOS B	5.3	38.3	0.52	0.50	0.52	33.5
5	T1	788	13	829	1.6	0.652*	12.7	LOS A	17.7	125.5	0.65	0.59	0.65	40.9
Approach		834	16	878	1.9	0.652	12.8	LOS A	17.7	125.5	0.64	0.58	0.64	40.6
North: Winnie Street (N)														
7	L2	75	3	79	4.0	0.355	42.0	LOS C	4.4	31.4	0.93	0.76	0.93	28.9
8	T1	104	1	109	1.0	0.355	37.6	LOS C	4.4	31.4	0.93	0.75	0.93	26.1
9	R2	15	2	16	13.3	0.355	42.4	LOS C	3.9	28.3	0.93	0.74	0.93	32.5
Approach		194	6	204	3.1	0.355	39.6	LOS C	4.4	31.4	0.93	0.75	0.93	27.9
West: Gerard Street (W)														
10	L2	40	0	42	0.0	0.683	11.8	LOS A	22.9	161.2	0.59	0.56	0.59	45.0
11	T1	1104	9	1162	0.8	0.683	9.3	LOS A	22.9	161.2	0.65	0.61	0.65	42.6
12	R2	172	2	181	1.2	0.683*	21.5	LOS B	14.8	104.1	0.87	0.79	0.87	33.6
Approach		1316	11	1385	0.8	0.683	10.9	LOS A	22.9	161.2	0.68	0.63	0.68	41.6
All Vehicles		2606	40	2743	1.5	0.683	16.5	LOS B	22.9	161.2	0.71	0.64	0.71	38.1

MOVEMENT SUMMARY

Site: 101 [FU PM - Parraween Street / Winnie Street (Site Folder: Future PM)]

Intersection of Parraween Street / Winnie Street

Future Conditions

PM Peak Hour Period

Site Category: (None)

Give-Way (Two-Way)

Vehicle Movement Performance														
Mov ID	Turn	INPUT VOLUMES		DEMAND FLOWS		Deg. Satn	Aver. Delay	Level of Service	95% BACK OF QUEUE		Prop. Que	Effective Stop Rate	Aver. No. Cycles	Aver. Speed
		[Total veh/h]	[HV veh/h]	[Total veh/h]	[HV %]				[Veh. veh]	[Dist m]				
South: Winnie Street (S)														
2	T1	139	9	146	6.5	0.129	0.7	LOS A	0.5	3.6	0.29	0.19	0.29	40.5
3	R2	63	0	66	0.0	0.129	5.9	LOS A	0.5	3.6	0.29	0.19	0.29	39.1
Approach		202	9	213	4.5	0.129	2.3	NA	0.5	3.6	0.29	0.19	0.29	39.6
East: Parraween Street (E)														
4	L2	54	0	57	0.0	0.042	4.1	LOS A	0.2	1.2	0.30	0.48	0.30	36.5
6	R2	116	0	122	0.0	0.152	5.9	LOS A	0.5	3.6	0.46	0.68	0.46	36.0
Approach		170	0	179	0.0	0.152	5.3	LOS A	0.5	3.6	0.41	0.62	0.41	36.2
North: Winnie Street (N)														
7	L2	110	1	116	0.9	0.179	4.6	LOS A	0.0	0.0	0.00	0.19	0.00	47.4
8	T1	208	11	219	5.3	0.179	0.0	LOS A	0.0	0.0	0.00	0.19	0.00	43.7
Approach		318	12	335	3.8	0.179	1.6	NA	0.0	0.0	0.00	0.19	0.00	46.1
All Vehicles		690	21	726	3.0	0.179	2.7	NA	0.5	3.6	0.19	0.29	0.19	40.3

MOVEMENT SUMMARY

▽ Site: 101 [FU PM - Parraween Street / Macpherson Street (Site Folder: Future PM)]

Intersection of Parraween Street / Macpherson Street

Future Conditions

PM Peak Hour Period

Site Category: (None)

Give-Way (Two-Way)

Vehicle Movement Performance

Mov ID	Turn	INPUT VOLUMES		DEMAND FLOWS		Deg. Satn	Aver. Delay	Level of Service	95% BACK OF QUEUE		Prop. Que	Effective Stop Rate	Aver. No. Cycles	Aver. Speed
		[Total veh/h]	[HV veh/h]	[Total veh/h]	[HV %]				[Veh. veh]	[Dist m]				
South: Macpherson Street (S)														
1	L2	94	0	99	0.0	0.092	4.6	LOS A	0.0	0.0	0.00	0.31	0.00	47.8
2	T1	72	0	76	0.0	0.092	0.0	LOS A	0.0	0.0	0.00	0.31	0.00	48.3
Approach		166	0	175	0.0	0.092	2.6	NA	0.0	0.0	0.00	0.31	0.00	48.0
North: Macpherson Street (N)														
8	T1	13	1	14	7.7	0.068	0.5	LOS A	0.3	2.2	0.29	0.50	0.29	54.7
9	R2	89	0	94	0.0	0.068	6.0	LOS A	0.3	2.2	0.29	0.50	0.29	44.3
Approach		102	1	107	1.0	0.068	5.3	NA	0.3	2.2	0.29	0.50	0.29	45.4
West: Parraween Street (W)														
10	L2	37	0	39	0.0	0.071	3.6	LOS A	0.3	1.8	0.19	0.48	0.19	44.4
12	R2	46	0	48	0.0	0.071	4.4	LOS A	0.3	1.8	0.19	0.48	0.19	44.0
Approach		83	0	87	0.0	0.071	4.1	LOS A	0.3	1.8	0.19	0.48	0.19	44.2
All Vehicles		351	1	369	0.3	0.092	3.7	NA	0.3	2.2	0.13	0.41	0.13	46.3



**ANNEXURE D: GREEN TRAVEL PLAN
(39 SHEETS)**

GREEN TRAVEL PLAN
FOR THE PROPOSED
RESIDENTIAL AGED CARE FACILITY &
INDEPENDENT LIVING UNITS
AT
50 - 88 PARRAWEEEN STREET & 59 - 67
GERARD STREET, CREMORNE

Prepared For:

Pathways Cremorne

Assessed and Approved by:



www.mclarentraffic.com.au

1 INTRODUCTION

McLaren Traffic Engineering (MTE) was commissioned by Morrison Design Partnership to provide a Green Travel Plan (GTP) for the proposed residential aged care facility & independent living units (*Pathways Cremorne*) at 50 - 88 Parraween Street & 59 - 67 Gerard Street, Cremorne

This GTP has been prepared in response to the *Planning Secretary's Environmental Assessment Requirements* for SSD-49472213 request for a Green Travel Plan, with the relevant requirements reproduced below:

10. Traffic, Transport and Accessibility

- *Proposals to promote sustainable travel choices for employees, residents, guests and visitors, such as connections into existing walking and cycling networks, minimising car parking provision, encouraging car share and public transport, providing adequate bicycle parking and high quality end-of-trip facilities, and implementing a Green Travel Plan.*

1.1 Development Characteristics and Approvals

The proposed development has the following characteristics relevant to traffic and parking impacts for the purposes of this assessment:

- Construction of a residential Aged Care Facility (RACF) and Independent Living Units (ILU) including:
 - 40 x beds for Residential (Aged) Care;
 - 14 staff required to operate and assist the residential aged care and the ancillary uses associated with the ILU and aged care facility. The ancillary uses of the site consist of the following:
 - Pool;
 - RACF dining areas and ILU dining areas;
 - Lounge areas;
 - Mens Shed;
 - Beauty / Hair areas.
 - 60 x Seniors Living dwellings consisting of:
 - 2 x one-bedroom units;
 - 18 x two-bedroom units, and;
 - 40 x three-bedroom units.

The site is shown on aerial imagery and a street map in **Figure 1** and **Figure 2**, respectively.

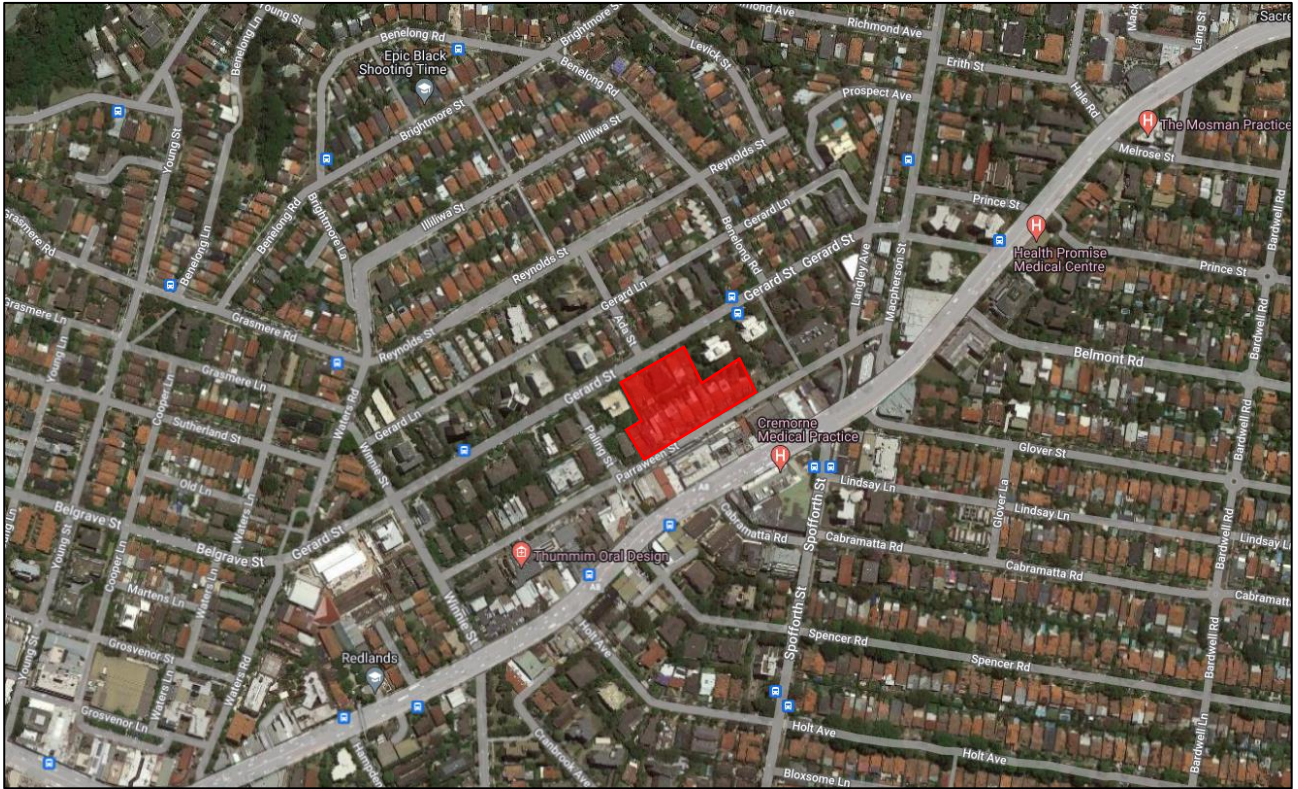

 Site Location

FIGURE 1: SITE CONTEXT – AERIAL IMAGE

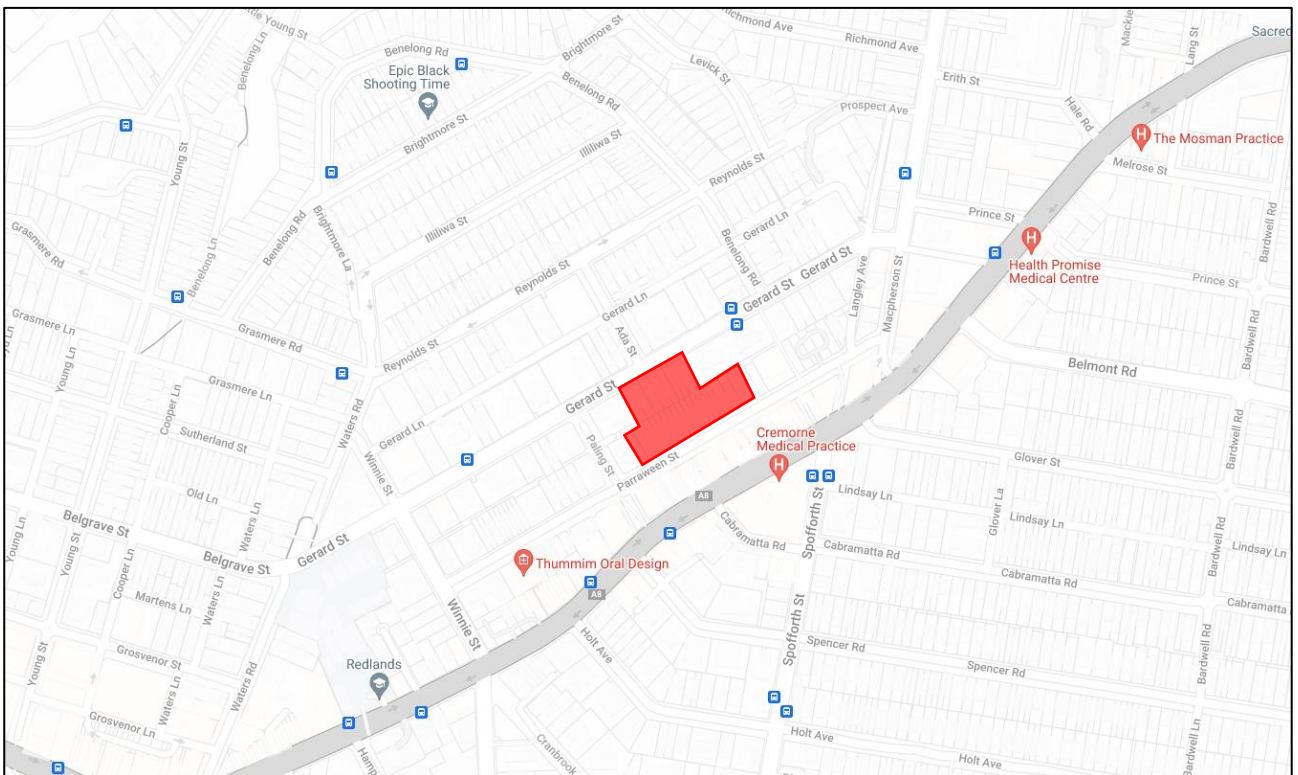

 Site Location

FIGURE 2: SITE CONTEXT – STREET MAP

1.2 References

A number of sources have been consulted to inform the preparation of this Green Travel Plan including:

- NSW Premier's Council for Active Living's Workplace Travel Plan Guidelines – Final Report (April 2010);
- NSW State Government Long Term Transport Master Plan;
- Transport for NSW Future Transport Strategy 2056;
- Australian Bureau of Statistics (ABS) Census Data;
- NSW Bureau of Transport Statistics Journey to Work Data;
- North Sydney Environmental Sustainability Strategy 2030;
- North Sydney Smart City Strategy 2019-2022;
- Northern Sydney Cycling Guide + Map;
- North Sydney Integrated Cycling Strategy;
- Public Transport or Private Vehicle: Factors That Impact on Mode Choice, Grace Corpuz (Transport Data Centre, New South Wales Ministry of Transport).

2 OBJECTIVES

Alternative modes of transport including walking, cycling and public transport quantifiably promote positive transport and health outcomes. The NSW State Government *Long Term Transport Master Plan* emphasises the importance of alternative transport options in the growth of Greater Metropolitan Sydney. Further to this, the *Future Transport Strategy 2056* also emphasises the importance of encouraging active travel (walking and cycling) and the use of public transport.

Reference is made to the *NSW Premier's Council for Active Living Workplace Travel Plan Guidance – Final Report (April 2010)* which provides examples of travel plans appropriate for different size and types of employers outlining that for:

20-250 employees

Mainly office-based employees

Likely to be beneficial to form alliances with other organisations in the locality also developing a WTP.

Could focus on key cost saving opportunities such as business travel and reducing fleet expenses.

While the employees at *Pathways Cremorne* are not strictly office-based employees this description best matches the nature of how staff work and their associated travel patterns.

This Green Travel Plan has been developed to identify a range of low-cost initiatives and promotions which will directly benefit staff and visitors travelling to the centre. This plan will help advise staff, residents, and visitors of sustainable and alternative transport options. The overall objective is to encourage staff, residents, and visitors to use alternate transport to reduce private car usage to/from the site, with the following positive implications:

- Reduced parking demand;
- Reduced traffic congestion and trip duration;
- Positive health outcomes from walking and cycling;
- Improved air quality and reduced per-capita emissions.

Overall, it is the responsibility of the Business Manager to distribute this Green Travel Plan via the existing information network channels such as the business website. It should be noted that a Travel Access Guide has been prepared detailing specific routes to nearby public transport facilities within **Annexure A**.

2.1 North Sydney Smart City Strategy 2019-2022

Reference is made to the *North Sydney Smart City Strategy 2019 – 2022* which outlines that a key aspect for the future of North Sydney is “*Smart, Sustainable Mobility*” with specific objectives relevant to note:

- *Improving transport intelligence, integration and sustainability*
- *Making parking more efficient*
- *Promoting active and innovative transport options*

Further reference is made to the *North Sydney Smart City Action Plan* which provides the following regarding “*Smart Travel*” with the relevant extracts presented in **Table 1**.

TABLE 1: NORTH SYDNEY SMART CITY ACTION PLAN – EXTRACT

Strategic Theme	Objectives	Actions
Smart Travel	Improve the experience and efficiency of travel in North Sydney	Install dynamic parking signs at Council owned carparks, reporting live parking availability
Smart Travel	Improve the experience and efficiency of travel in North Sydney	Provide open access to live parking data, and explore options for app(s)
Smart Travel	Improve the experience and efficiency of travel in North Sydney	Support the development/delivery of on-line journey planning tools and apps by sharing relevant data
Smart Travel	Increase up-take of low emission transport options	Prepare an Electric Vehicle (EV) Policy to coordinate Council action (accounting for planning, promotion, infrastructure. services, etc.)
Smart Travel	Increase up-take of low emission transport options	Explore options to install EV charging stations in Council owned car parks and other infrastructure
Smart Travel	Improve our understanding of transport in North Sydney	Expand use of cycleways counters
Smart Travel	Improve our understanding of transport in North Sydney	Monitor and analyse transport data to inform future transport planning and pricing

From the above, it is evident that North Sydney is planned to improve the connectivity of the city through implementation of transport initiatives and infrastructures. As part of the redevelopment of the site, there will be additional kerbside parking restored to the public along Parraween Street and as a result there is the opportunity / potential to provide infrastructure to support the Smart City Action Plan. For example, Electric Vehicle charging stations can be provided, in addition to potential public domain bicycle parking.

3 EXISTING ALTERNATIVE TRANSPORT FACILITIES

3.1 Public Transport – Bus Services

The proposed development is serviced by existing bus stops, with the most convenient bus stops shown in **Figure 3**.

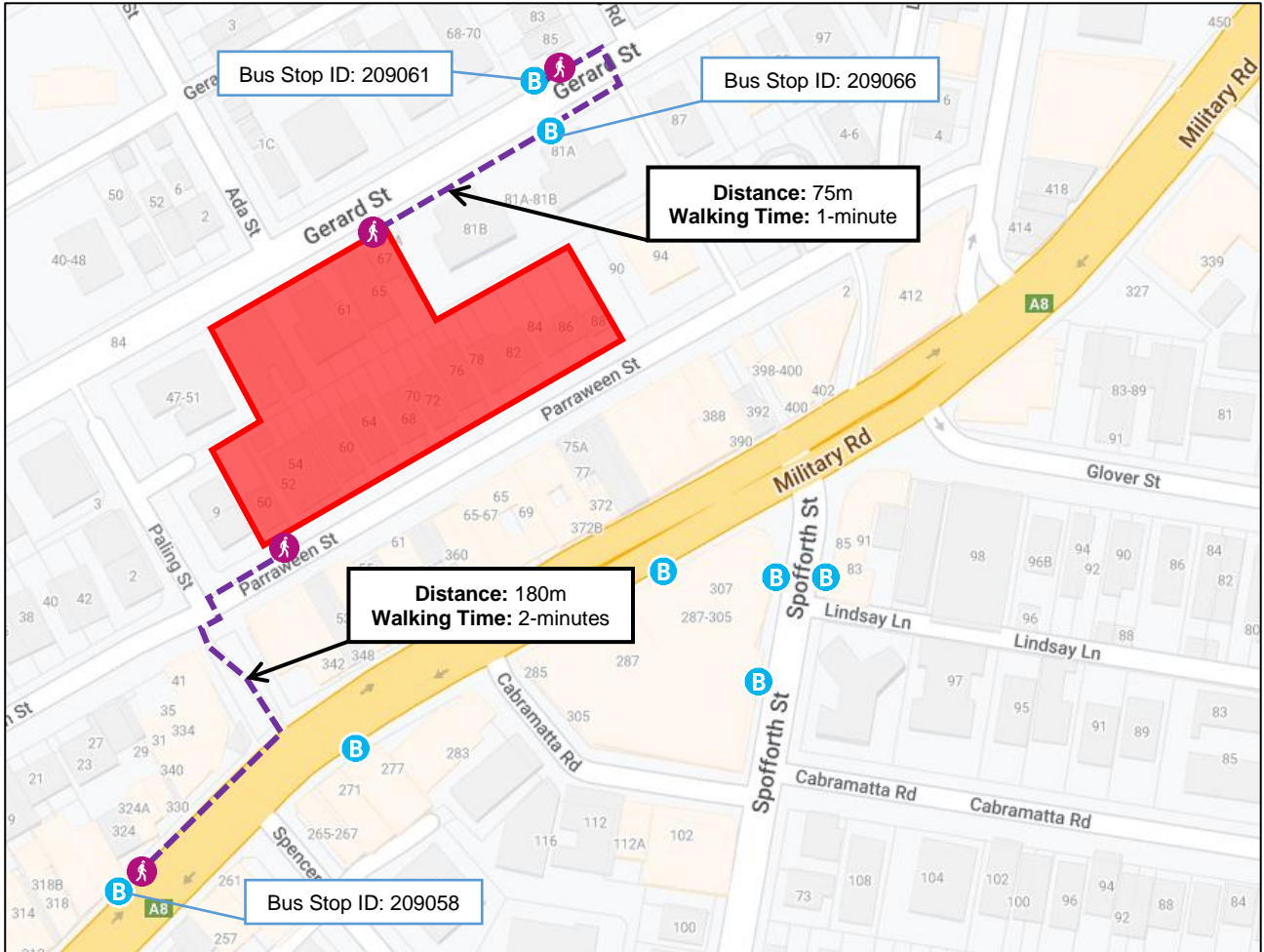

█ Site Location

FIGURE 3: BUS STOP LOCATIONS

The bus stops services the existing bus routes, as summarised in **Table 2**.

TABLE 2: BUS ROUTE SUMMARY

Bus Route ID	Bus Destinations	Bus Service Provider
Bus Stop ID: 209066 & ID: 209061		
243	Spit Junction to Neutral Bay and City Wynyard via North Cremorne	Keolis Downer Northern Beaches
Bus Stop ID: 209058		
100	Taronga Zoo to City QVB	Keolis Downer Northern Beaches
114	Royal North Shore Hospital to Balmoral	
144	Chatswood to Manly via St Leonards	
144N	North Sydney to Manly (Night Service)	
150X	Milsons Point to Manly (Night Service)	
165X	City Wynyard to South Curl Curl (Express Service)	
170X	City Wynyard to Manly (Express Service)	
172X	City Wynyard to Warringah Mall via North Balgowlah (Express Service)	
173X	City Wynyard to Warringah Mall via Balgowlah Shops (Express Service)	
174X	City Wynyard to Narraweena (Express Service)	
176X	City Wynyard to Dee Why via North Curl Curl (Express Service)	
177X	City Wynyard to Dee Why via Wingala (Express Service)	
228	Milsons Point to Clifton Gardens	
229	Milsons Point to Beauty Point via Balmoral Heights	
230	Milsons Point to Mosman Wharf via North Sydney	
246	City Wynyard to Balmoral Heights	
249	City Wynyard to Beauty Point	

These bus routes are provided by Keolis Downer Northern Beaches. An extract of the Keolis Downer Northern Beaches bus operator map is reproduced in **Figure 4**.

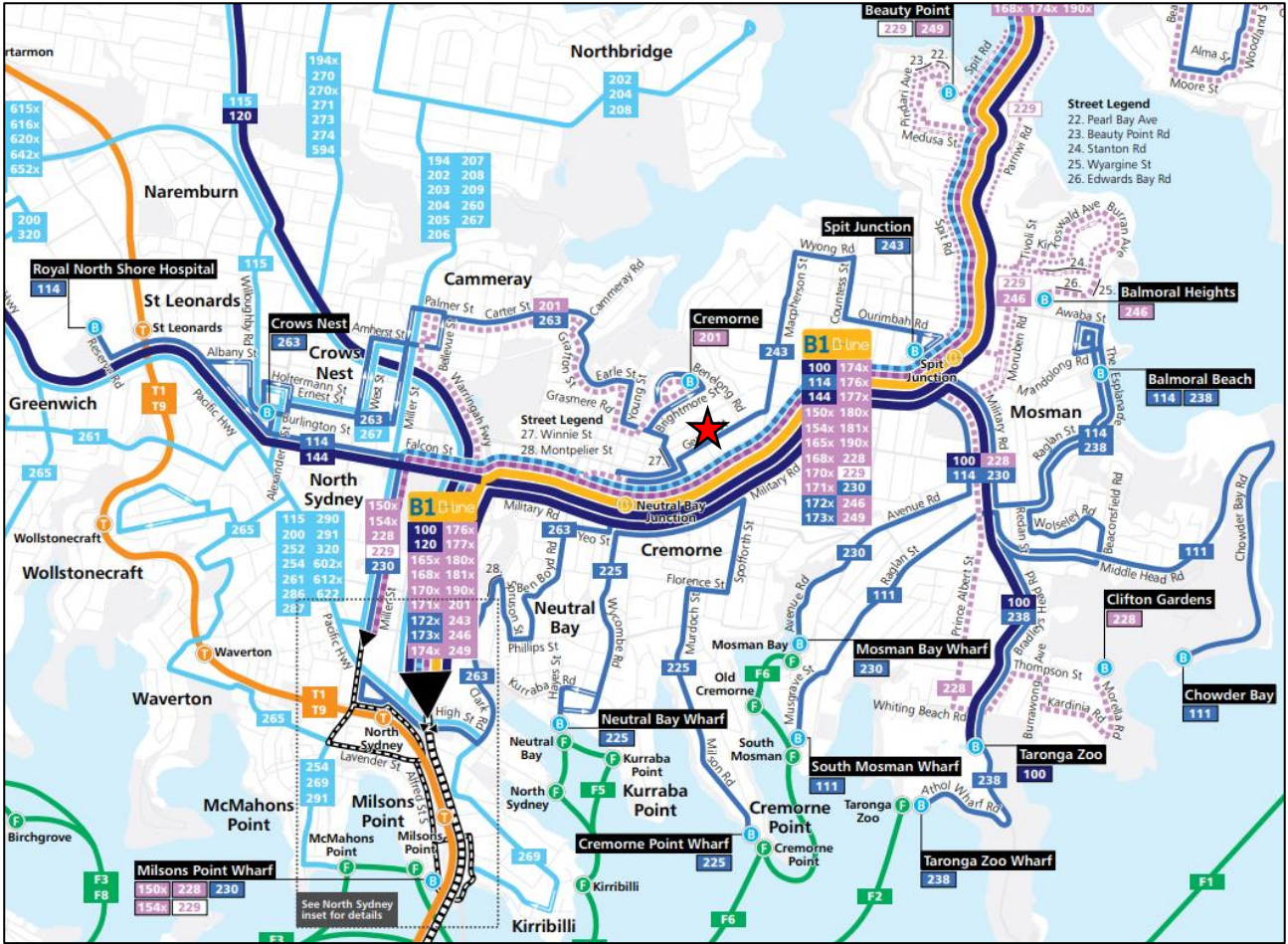

★ Site Location

FIGURE 4: EXTRACT OF THE KEOLIS DOWNER NORTHERN BEACHES BUS OPERATION MAP

Table 3 outlines the frequency of the local bus services provided by *Keolis Downer Northern Beaches*, which pass the site along Epping Road. It should be noted that the timetables of the bus services below may change. The most recent timetables can be accessed via TfNSW's website (transport.info/routes/bus).

**TABLE 3: BUS ROUTE FREQUENCY
PUBLIC BUS SERVICES**

Route	Destination	Frequency		
		AM Peak ⁽¹⁾	Off-Peak ⁽²⁾	PM Peak ⁽³⁾
243	City Wynyard to Spit Junction via North Cremorne	1 hour	30 minutes	1 hour
	Spit Junction to Neutral Bay and City Wynyard via North Cremorne	12 minutes	1 hour	1 hour
100	Taronga Zoo to City QVB	<10 minutes	10 minutes	<10 minutes
114	Royal North Shore Hospital to Balmoral	20 minutes	20 minutes	30 minutes
	Balmoral to Royal North Shore Hospital	10 minutes	20 minutes	12 minutes
144	Chatswood to Manly via St Leonards	12 minutes	10 minutes	10 minutes
	Manly to Chatswood via St Leonards	12 minutes	10 minutes	<10 minutes
144N	North Sydney to Manly (Night Service)	(4)	(4)	(4)
	Manly to North Sydney (Night Service)	(4)	(4)	(4)
150X	Milsons Point to Manly (Express Service)	(4)	(4)	20 minutes
	Manly to Milsons Point (Express Service)	<10 minutes	(4)	(4)
165X	City Wynyard to South Curl Curl (Express Service)	(4)	(4)	15 minutes
	South Curl Curl to City Wynyard (Express Service)	10 minutes	(4)	(4)
170X	City Wynyard to Manly (Express Service)	(4)	(4)	10 minutes
	Manly to City Wynyard (Express Service)	10 minutes	(4)	(4)
172X	City Wynyard to Warringah Mall via North Balgowlah (Express Service)	30 minutes	1 hour	20 minutes
	Warringah Mall to City Wynyard via North Balgowlah (Express Service)	15 minutes	1 hour	20 minutes
173X	City Wynyard to Warringah Mall via Balgowlah Shops (Express Service)	20 minutes	20 minutes	20 minutes
	Warringah Mall to City Wynyard via Balgowlah Shops (Express Service)	30 minutes	20 minutes	20 minutes
174X	City Wynyard to Narrabeena (Express Service)	(4)	(4)	20 minutes
	Narrabeena to City Wynyard (Express Service)	15 minutes	(4)	(4)
176X	City Wynyard to Dee Why via North Curl Curl (Express Service)	(4)	(4)	30 minutes
	Dee Why to City Wynyard via North Curl Curl (Express Service)	12 minutes	(4)	(4)
177X	City Wynyard to Dee Why via Wingala (Express Service)	(4)	(4)	1 hour
	Dee Why to City Wynyard via Wingala (Express Service)	10 minutes	(4)	(4)

228	Milsons Point to Clifton Gardens	(4)	(4)	1 hour
	Clifton Gardens to Milsons Point	1 hour	(4)	(4)
229	Milsons Point to Beauty Point via Balmoral Heights	(4)	(4)	(4)
	Beauty Point to Milsons Point via Balmoral Heights	(4)	1 hour	(4)
230	Milsons Point to Mosman Wharf via North Sydney	12 minutes	15 minutes	12 minutes
	Mosman Wharf to Milsons Point via North Sydney	<10 minutes	20 minutes	15 minutes
246	City Wynyard to Balmoral Heights	(4)	(4)	10 minutes
	Balmoral Heights to City Wynyard	<10 minutes	(4)	(4)
249	City Wynyard to Beauty Point	(4)	(4)	1 hour
	Beauty Point to City Wynyard	20 minutes	(4)	(4)

NOTE:

- (1) AM peak period – 7:00_{AM} to 8:00_{AM};
- (2) Off-peak period – 12:00_{PM} to 1:00_{PM};
- (3) PM peak period – 4:00_{PM} to 5:00_{PM};
- (4) Does not operate during the given period.

As shown, the bus stops are frequently serviced by several bus routes, servicing a range of destinations across the North Shore and Sydney CBD.

While each individual bus service generally has a peak-hour frequency of one service every 15 to 20-minutes which may require commuters to plan their trips in advance, the bus stops themselves have a departure/arrival every few minutes to various destination creating a high level of bus accessibility for the proposed residential aged care facility and independent living units. The bus services within close proximity of the site are considered an attractive alternate transport mode.

3.2 Public Transport – Train Services

The proposed development is not within convenient walking distance to any train station, however the bus routes mentioned in **Section 3.1** provide direct connection to the following train stations:

- Wynyard Station (243, 100, 165X, 170X, 172X, 173X, 174X, 176X, 177X, 246, 249);
- North Sydney Station (144N);
- Milsons Point Station (150X, 228, 229, 230);
- St Leonards Station (114, 144);
- Chatswood Station (144).

3.3 Active Transport – Cycling

The subject site has access to cycle paths as presented within *Northern Sydney Cycling Guide + Map* cycling guide prepared by North Sydney Council. The cycling guide provides a map detailing various cycle paths which are graded as per the following:

- Separated Bicycle Path;
- Shared User Path;
- Marked On-road Bicycle Route;
- High Current Bicycle Use (may include difficult conditions if separated paths are not provided).

Marked cycle routes encourage individuals to utilise bicycles as a mode to travel, reducing motor vehicle congestion and overall motor vehicle usage. To travel to/from the north, cyclists will need to utilise Military Road (labelled as “High Current Bicycle Use”) to connect to Merlin Street (labelled as “Separated Cycle Path”). To travel to/from the south, cyclists can utilise Spofforth Street (labelled as “High Current Bicycle Use”). To travel to/from the east and west, cyclists can utilise Military Road.

The location of the site relative to the surrounding cycling routes is depicted in **Figure 5**, with a copy of the *Northern Sydney Cycling Guide + Map* provided in **Annexure B**.

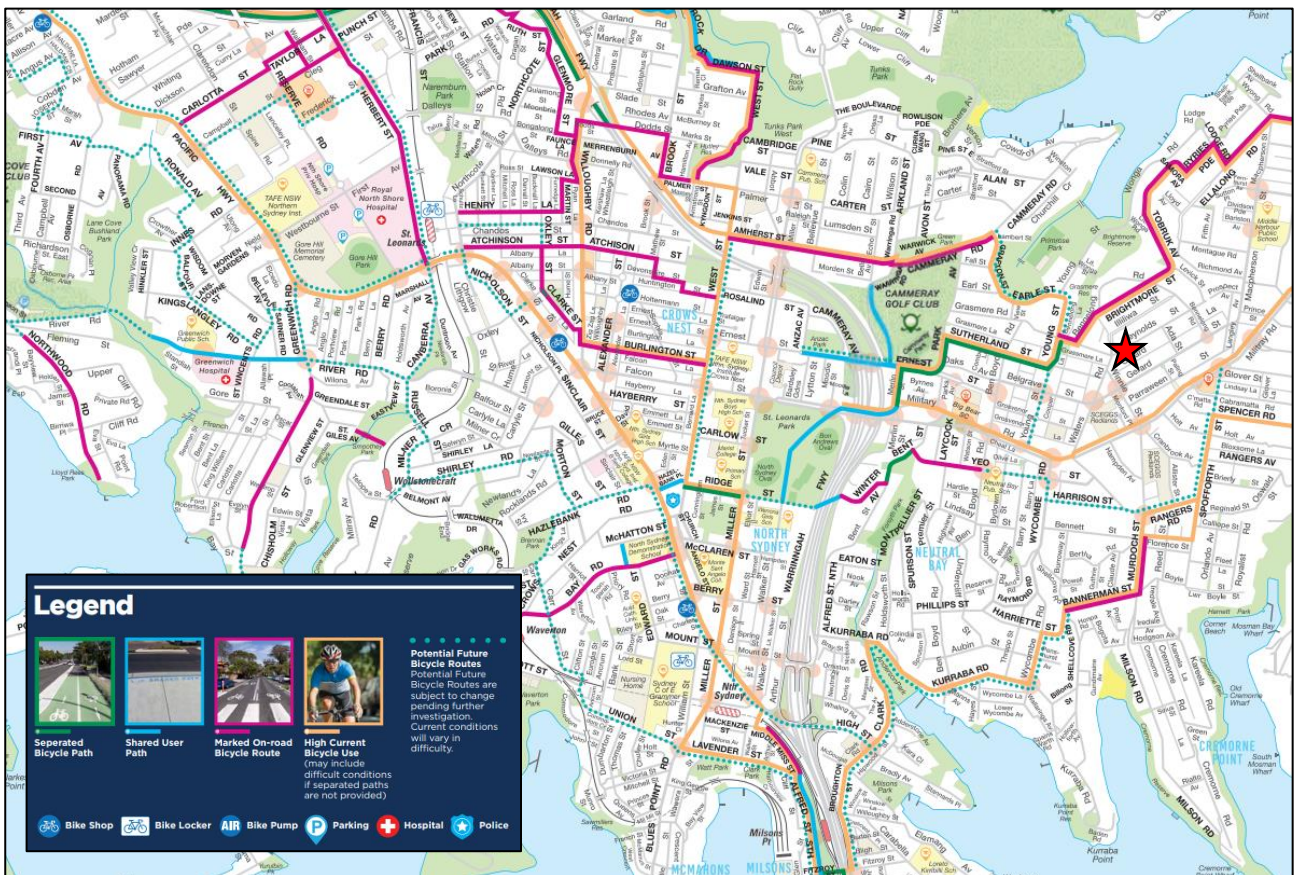

★ Site Location

FIGURE 5: SITE CONTEXT – CYCLING ROUTES

Further, the cycling map details “Potential Future Bicycle Routes”. Any upgrades to the existing cycle routes should encourage individuals to give cycling to work a trial. Staff should be informed when more of these upgrades are proposed and/or constructed.

3.4 Active Transport – Walking

Pedestrian walking facilities are abundantly provided within close proximity to the site. Specific details of the walking facilities are provided below:

- **Gerard Street:**
 - Pedestrian walkways are provided along both sides of the road;
 - Signalised pedestrian crossing at the intersection of Gerard Street / Winnie Street, providing a connection between the north and south sides of Gerard street.
- **Paling Street:**
 - Pedestrian walkways are provided along both sides of the road providing a connection between Parraween Street and Gerard Street.
- **Parraween Street:**
 - Pedestrian walkway provided on both sides of the road;
 - Pedestrian “Zebra Crossing” near Paling Street;
 - Pedestrian “Zebra Crossing” near Langley Avenue;
 - “Cremorne Garden Plaza” provides connection between Parraween Street and Military Road.
- **Military Road:**
 - Pedestrian walkway provided on both sides of the road;
 - Signalised pedestrian crossing at the intersection of Military Road / Winnie Street, providing a connection between the north and south sides of Military Road;
 - Signalised Pedestrian Crossing near Cabramatta Road, providing a connection between the north and south sides of Military Road.

There are numerous existing pedestrian walking facilities that have been provided by council within close proximity of the site. Staff who live close to the site may utilise these facilities to reduce the number of vehicles driven.

4 ALTERNATIVE TRANSPORT STRATEGY

4.1 Timeframe

This Green Travel Plan will apply from the issue of the Occupation Certificate for any works performed under this development application.

4.2 Existing Transport Use of Employees in the Surrounding Area

To assist in setting the targets and milestones for transport use of staff, the NSW Bureau of Transport Statistics 2016 Journey to Work data has been consulted for three (3) SA2 statistical areas, being Cremorne – Cammeray (433), Mosman – North (435) and Mosman South (435), as the subject site lies close to the border of these three (3) SA2 zones. The data shows that on average 61% of workers in these areas drive to and from work, with the detailed travel mode split summarised in **Table 4** and illustrated in **Figure 6**. It should be noted that the 2021 census data was not consulted as Sydney was under COVID-19 lockdowns during the 2021 census date.

TABLE 4: CREMORNE – CAMMERAY, MOSMAN – SOUTH & MOSMAN – NORTH EXISTING TRAVEL MODE SPLIT

TRAVEL MODE	CREMORNE - CAMMERAY	MOSMAN	AVERAGE
	MODE SHARE	MODE SHARE	
Train	12%	8%	10%
Bus	11%	11%	11%
Ferry	0%	0%	0%
Tram	0%	0%	0%
Taxi	0%	0%	0%
Car, as driver	57%	66%	61%
Car, as passenger	5%	3%	4%
Truck	1%	1%	1%
Motorbike/scooter	1%	1%	1%
Bicycle	0%	1%	1%
Walked only	11%	8%	9%
Other Mode	1%	1%	1%

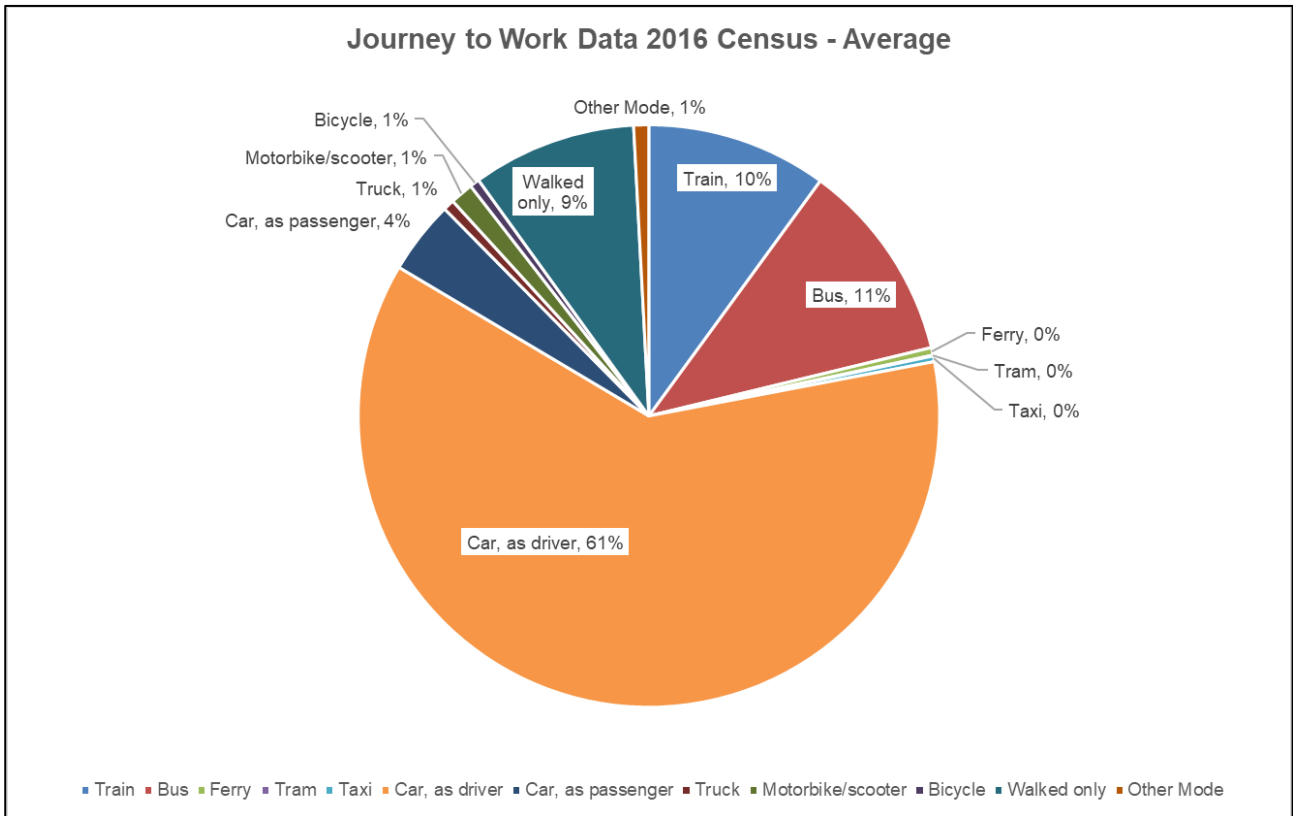

FIGURE 6: AVERAGE JTW WORK DATA FOR CREMORNE – CAMMERAY AND MOSMAN

4.3 Cycling and Walking Suitability

The following assumptions have been made to produce this assessment:

- A reasonable cycle time of twenty (20) minutes for staff (5km cycling distance);
- A reasonable walking time of ten (10) minutes for staff (800m walking distance);

Figure 7 and **Figure 8** depicts the approximate walking and cycling catchment area relative to the subject site, respectively.

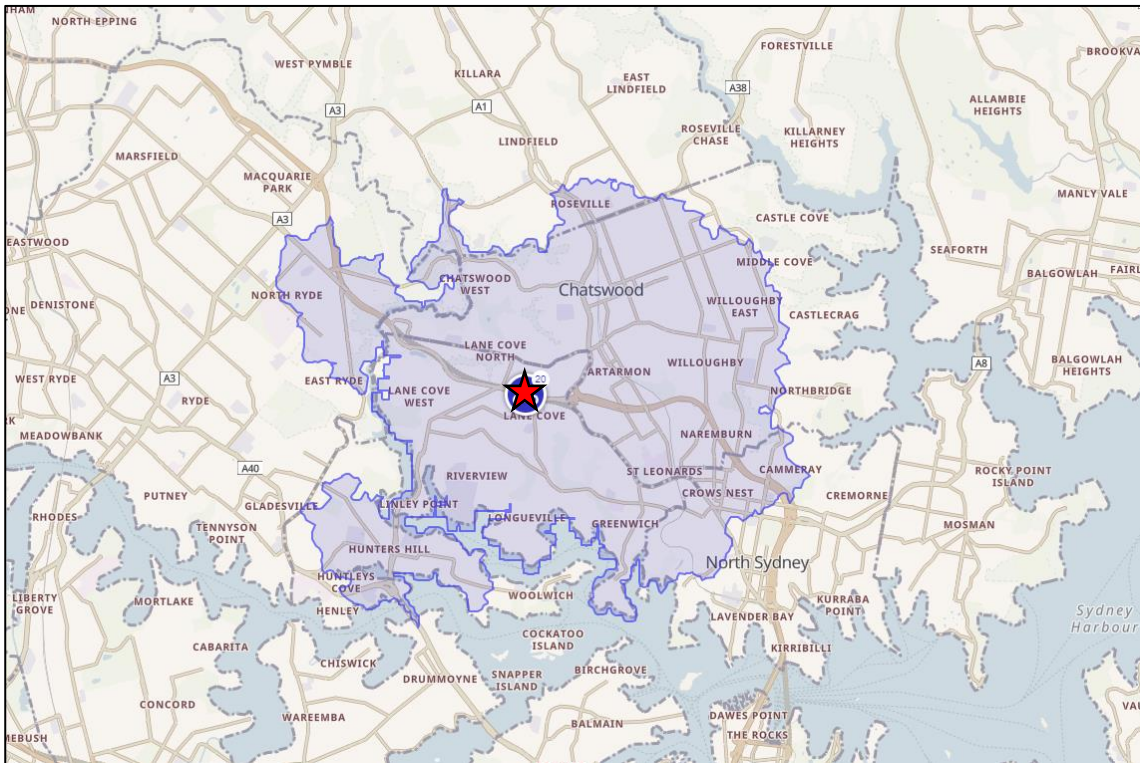

★ Site Location

FIGURE 7: INDICATIVE 20-MINUTE CYCLING CATCHMENT AREA

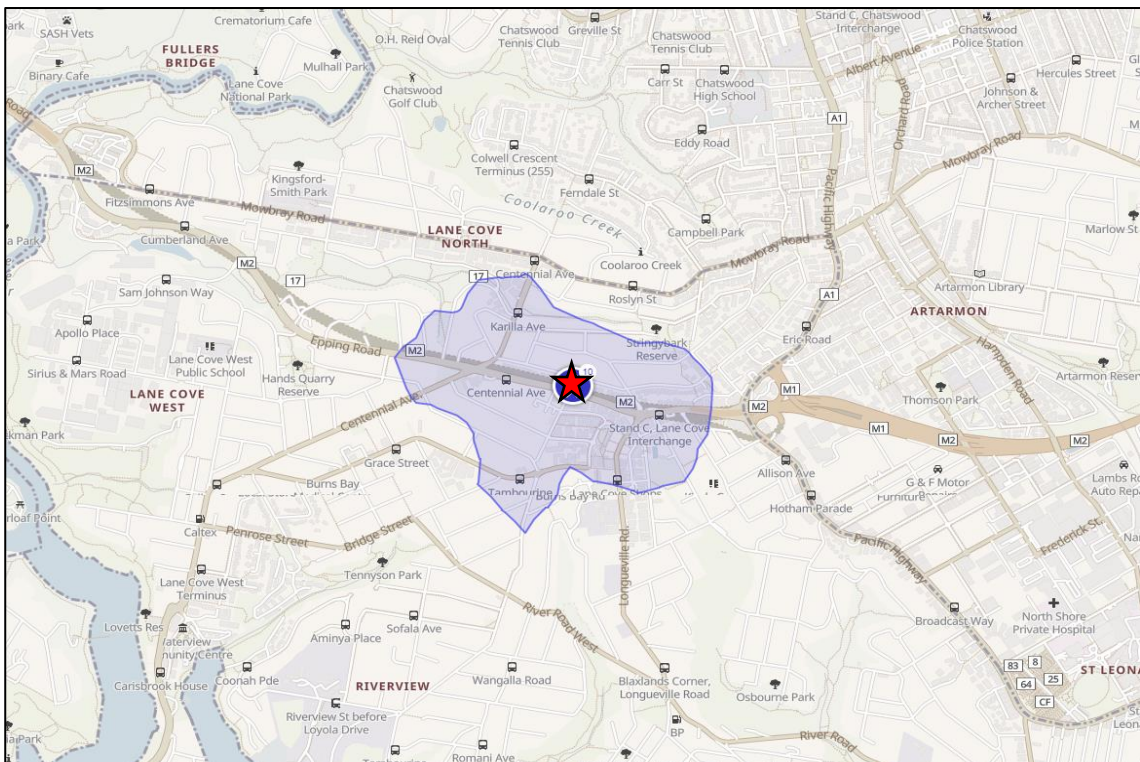

★ Site Location

FIGURE 8: INDICATIVE 10-MINUTE WALKING CATCHMENT AREA

4.4 Targets and Milestones

Through the implementation of the actions described in **Section 5**, continual increases in alternative transport use are anticipated for the duration of this Green Travel Plan’s effectiveness. It should be noted that there is high potential for employees to reduce their private vehicle usage based on the data obtained from the JTW 2016 Census.

4.4.1 Staff Targeted Transport Mode Split

An achievable target for the travel mode split for staff is to aim to reduce the existing driver percentage by 20% for staff over a 10-year period. This would approximately align the staff transport mode split with the Journey to Work average of the area. An overall target of 10% private vehicle reduction in the first three (3) years and a further 10% reduction in the subsequent seven (7) years is applied for staff. The resulting 1, 3, 5, and 10-year goals for the travel mode split for staff is depicted in **Table 5**.

TABLE 5: TARGETED TRANSPORT MODE SPLIT

Travel Mode	Usage Rate				
	Existing	1yr	3yr	5yr	10yr
Train	10%	11%	12%	13	14%
Bus	11%	12%	13%	14	15%
Car, as driver	61%	56%	51%	46%	41%
Car, as passenger	4%	4%	4%	4%	4%
Truck	1%	1%	1%	1%	1%
Motorbike/scooter	1%	1%	1%	1%	1%
Bicycle	1%	4%	6%	9%	10%
Walked only	9%	10%	11%	11%	11%
Other Mode	1%	1%	1%	1%	1%

4.5 Measurement and Reporting

4.5.1 Frequency

Travel mode surveys should be undertaken annually to report the staff travel mode against the targeted transport mode split for the lifecycle of the development.

4.5.2 Method

The travel plan coordinator will conduct surveys annually and from time to time when the Green Travel Plan is updated. Further, a copy of the travel survey has been provided within **Annexure C** which is to be filled out by all staff for the updated surveys. The surveys will also include a feedback field such that staff can suggest schemes or initiatives for the development to adopt to encourage alternative transport use.

4.5.3 Reporting

Following the completion of surveys, the results will be compiled into a report for review by the travel plan coordinator to plan for further initiatives if required.

5 Projects and Programs

The following actions form the basis for the implementation of the Green Travel Plan.

Collectively, these actions have been designed to help achieve the targets and milestones set out in **Section 4**. It should be noted that these actions are potential options that should be investigated and implemented as appropriate. These initiatives are generally targeted to staff as visitors to the site will typically use transport modes most convenient to them.

5.1 Initiatives to Specifically Reduce Private Car Use

The following initiatives are suggested to lower private car usage by providing for facilities or programs with the aim to allow for greater flexibility in the choice of travel mode to and from the centre. The strategies that can be implemented with this goal in mind are not limited to the following actions as shown in **Table 6**, but these are the basis for further reduction in private car reliance.

TABLE 6: INITIATIVES TO REDUCE PRIVATE CAR USAGE

Action	Cost	Target Group	Date
Provide large lockers or storage areas for the storing of books and other bulky items	Moderate	Staff	Ongoing
Encourage staff to plan ahead and to transport heavy/bulky items once or twice per week only	Minimal	Staff	From date of implementation
Limit the number of car spaces when more sustainable transport options are available in the future	Minimal	Staff and Visitors	Ongoing
Charge a fee for car parking which is pledged toward sustainable transport initiatives	Moderate	Staff	Ongoing
Provide pre-loaded opal cards to staff dedicated to public transport use	Moderate	Staff	Ongoing

5.2 Public Transport Initiatives

The following actions are focused on encouraging staff, residents, and visitors to partake in public transport when travelling to and from the site. The strategies to be implemented are not limited to the following actions as shown in **Table 7**, but these are the basis for further development of public transport options.

TABLE 7: PUBLIC TRANSPORT INITIATIVES

Action	Cost	Target Group	Date
Prepare a Transport Access Guide (TAG) for the site (TAG provided in Annexure A)	Minimal	Staff, Residents and Visitors	From date of implementation
Offer staff subsidies to offset public transport costs	Minimal	Staff	Ongoing
Provide a shuttle bus for staff to North Sydney Train Station	Minimal	Staff, Residents and Visitors	Ongoing
Put up a notice board with leaflets and maps showing the main public transport routes to and from the site.	Minimal	Staff, Residents and Visitors	From date of implementation
Develop a map showing public transport routes to the site.	Minimal	Staff, Residents and Visitors	Ongoing

5.3 Walking and Cycling Initiatives

5.3.1 Walking

The following actions are focused on encouraging staff, residents, and visitors to partake in walking when travelling to and from the site. The strategies to be implemented are not limited to the following actions as shown in **Table 8**, but these are the basis for further development of active transport options.

TABLE 8: WALKING INITIATIVES

Action	Cost	Target Group	Date
Identify staff living near work that may be interested in walking to work	Nil	Staff	Ongoing
Produce a map showing safe walking routes to and from the site with times, not distances, to local facilities, such as shops and public transport	Minimal	Staff, Residents and Visitors	From date of implementation
Provide showers, lockers and changing room facilities	As per construction	Staff	From date of implementation
Implement incentive schemes to encourage employees to walk to work	Minimal	Staff	From date of implementation
Provide subsidised panniers or backpacks for staff committed to active travel	Minimal	Staff	Ongoing
Take part in ' <i>National Walk to Work Day</i> '	Nil	Staff	Annually
Have some ' <i>TravelSmart Get to Work</i> ' days encouraging staff to commute by alternative transport modes	Nil	Staff	Annually
Promoting the potential of active travel to work as an opportunity to stay active themselves	Nil	Staff and Residents	Ongoing

5.3.2 Cycling

The following actions are focused on encouraging staff, residents, and visitors to partake in cycling when travelling to and from the site. The strategies to be implemented are not limited to the actions as shown in **Table 9**, but these are the basis for further development of active transport options.

TABLE 9: CYCLING INITIATIVES

Action	Cost	Target Group	Date
Organise an after-work ride. It does not have to be long or strenuous and could end up somewhere for dinner. This idea is to encourage people who might be reluctant to cycle to give it a go	Nil	Staff	Quarterly
Have good, secure bicycle parking in an easily accessible location	Minimal	Staff, Residents and Visitors	Ongoing
Provide bicycle parking for visitors	Minimal	Visitors	Ongoing
Ensure bicycle parking is clearly visible or provide signage to direct people to cycle bays	Minimal	Staff, Residents and Visitors	From date of implementation
Circulate maps of cycle paths in the vicinity	Nil	Staff, Residents and Visitors	Ongoing
Participate in annual events such as 'Ride to Work Day'	Nil	Staff	Annually
Arrange information sessions outlining cycling safety and health benefits	Minimal	Staff	Annually
Hold yearly cycling safety sessions, promoting how to be a safe cyclist on the roads	Minimal	Staff and Residents	Annually
Hold competitions and offer prizes for staff that walk or ride to work	Minimal	Staff	From date of implementation
Provide salary sacrifice options for purchase of bikes or other micro-mobility options	Minimal	Staff	From date of implementation
Allocate time in staff meetings to share tips and support for staff wanting to start cycling	Nil	Staff	Ongoing

5.4 Sustainable Transport Initiatives

5.4.1 Carpooling

The following actions are focused on encouraging staff, residents, and visitors to partake in carpooling and limiting the number of cars used to travel when travelling to and from the site. The strategies to be implemented are not limited to the following actions as shown in **Table 10**, but these are the basis for further development of alternative transport.

TABLE 10: CARPOOLING INITIATIVES

Action	Cost	Target Group	Date
Set up carpooling databases for staff	Nil	Staff	From date of implementation
Promote carpooling at quarterly staff meetings to encourage carpooling amongst staff members with similar travel routes	Nil	Staff	Quarterly
Encourage use of carpooling apps and/or subsidise costs of carpooling trips	Nil	Staff	From date of implementation
Subsidise the cost of fuel for carpooling staff	Minimal	Staff	From date of implementation

5.4.2 Car Parking

The following actions are focused on encouraging staff to partake in alternative options when travelling to and from the site. The strategies to be implemented are not limited to the following actions as shown in **Table 11**, but these are the basis for further development of alternative transport.

TABLE 11: CAR PARKING INITIATIVES

Action	Cost	Target Group	Date
Identify priority users of car park e.g. people with disabilities, carpoolers	Nil	Staff	From date of occupation

5.5 Use of Incentives

Many of the alternative transport initiatives described above require the willing participation of employees and visitors and would not otherwise be effective. The incentivisation of alternative transport options could increase the number of employees and visitors using alternative transport options.

The direct advertisement for alternative transport use is suggested as part of increasing alternative transport utilisation. Some incentivisation strategies are outlined below:

- Provide a yearly seminar of the benefits of utilising public transport including reduced greenhouse gas emissions and health benefits;
- Provide subsidies for staff who use public transport full-time;
- Promote Carpooling among staff who utilise private vehicles to work;
- Provide a shuttle bus connecting the site to key locations such as North Sydney Train Station;

The above incentivisation strategies could be implemented to boost uptake of alternative travel modes if annual targets are not met.

In addition, a review of the NSW Household Travel Survey by Grace Corpuz identified several factors that affected the use of alternative travel options, identifying the following factors as most influential on alternative transport use (in order of importance):

- Parking capacity and arrangements (destination factor);
- Where a vehicle is not available or accessible (origin factor);
- Where it is cheaper (origin & destination factor);
- Travel time (origin & destination factor);
- Convenience (origin & destination factor);
- Accessibility (origin & destination factor).

Future development of this Green Travel Plan should take into consideration the factors listed above.

6 Implementation Strategy

6.1 Management and Authority

The distribution of and implementation of the measures detailed in this Green Travel Plan is the responsibility of the management bodies of the proposed development. It is the responsibility of the manager to include alternative transport methods and initiatives in appropriate centre communication methods.

Accordingly, authority is provided to the management to implement measures, review the plan and undertake further relevant and appropriate actions.

6.2 Distribution

The proposed development's management will be responsible to inform staff and visitors about any initiatives that they choose to implement via the relevant network channels such as the business website or newsletters.

6.3 Proposed Incentives

The proposed incentives to be adopted by the proposed development and relevant timeframes for completion is presented in **Table 12**.

TABLE 12: PROPOSED INCENTIVES

Inputs	Activities			Outputs	Impacts	Outcomes
	What	Who	When			
What resources are required?				What needs to be created?	Performance indicators	What will be achieved?
Funds for bicycle racks	Provision of 14 bicycle racks for staff	Manager	Prior to site operation	Bicycle rack installation	Decrease reliance on private vehicles. 100% staff engaged with Travel Plan. Increase uptake of active transport for staff.	Improve health and wellbeing of staff
Funds for Opal Cards	Pre-loaded opal cards	Manager	Within 6-months	Public transport fare subsidies		Reduce the number of vehicles arriving at the site during peak periods
Staff Resources	Time in staff meetings to share tips and support for staff wanting to start walking to and from work.	Manager	Within 1-month and ongoing	Communication materials		Education for all staff about different travel options to the work.
Travel Plan Coordinator Organisation	Promote active travel as a means to support staff health and wellbeing	Manager	Within 1-month and ongoing	Communication materials		Improve health and wellbeing of staff
Limit the number of car spaces (see Table 6)	Restrict the number of parking spaces available on each parking level	Manager	Within 1-month and ongoing	Communication Materials and Signage (possibly)		Reduce the number of vehicles arriving at the site during peak periods
Provide showers, change rooms and lockers (see Table 9)	Allow access for employees to access the end of trip facilities	Manager	Prior to site operation	Access opportunities for staff.		Reduce the number of vehicles arriving at the site during peak periods

7 Travel Access Guide

A Travel Access Guide (TAG) outlining relevant public transport maps and timetables is provided within **Annexure A**. More recent updates to public transport services, routes and timetables can be accessed via the Trip Planner (transport.info).



**ANNEXURE A: TRAVEL ACCESS GUIDE
(6 SHEETS)**

**TRAVEL ACCESS GUIDE FOR
THE PROPOSED
RESIDENTIAL AGED CARE FACILITY &
INDEPENDENT LIVING UNITS**

**AT 50 - 88 PARRAWEEN STREET & 59 - 67 GERARD
STREET, CREMORNE**

Prepared for:

Pathways Cremorne

Assessed and Approved by:



Address: Shop 7, 720 Old Princes Highway Sutherland NSW 2232
Postal: P.O Box 66 Sutherland NSW 1499

Telephone: +61 2 9521 7199
Web: www.mclarentraffic.com.au
Email: admin@mclarentraffic.com.au

Division of RAMTRANS Australia ABN: 45067491678 RPEQ: 19457

Transport Planning, Traffic Impact Assessments, Road Safety Audits, Expert Witness

TRAVEL MODES FOR YOU

The proposed residential aged care facility & independent living units are located at 50 - 88 Parraween Street & 59 - 67 Gerard Street, Cremorne. This Travel Access Guide outlines the various transport modes available to you when travelling to and from the proposed Residential Aged Care Facility & Independent Living Units.

Pathways Cremore is well serviced by alternate transport modes connecting the centre with the rest of Sydney. In many cases it may be faster and more convenient to travel to the site by alternate transportation than private vehicle.



Public Bus



Train

PLANNING AHEAD

To ensure that you arrive to the subject site on time, plan ahead using the following resources provided by **Transport for New South Wales (TfNSW)**:

- **Trip Planner** accessed via <https://transportnsw.info/>
- **Opal Travel** – accessed via a downloadable application on your mobile device
- **TripView** – accessed via a downloadable application on your mobile device
- **City Mapper** – accessed via a downloadable application on your mobile device (<https://citymapper.com/>)

The above resources provide real-time service updates, detailed service information, walking and cycling distances and accessibility details.

USING ACTIVE TRANSPORT MODES FOR ALL OR SOME OF YOUR JOURNEY

Using active transport modes such as walking or cycling, for a part of your daily journey to and/or from the centre is a great way to improve and maintain your physical health along with your mental health. It can provide some well needed 'me-time' in your day.

PUBLIC TRANSPORT – OPAL FARES

The use of an OPAL card ensures the most efficient way to use public transport. A summary OPAL fares for available transport modes for children and adults are provided below:

- Adult OPAL fares:
 - Adult fares are capped to **\$16.80** a day or **\$50** a week
 - A discount of 30% fare discount incurs when using public transport outside of the peak times
- Child OPAL fares:
 - Child fares are capped to **\$8.40** a day or **\$25** a week
 - A discount of 30% fare discount incurs when using public transport outside of the peak times

For more information regarding OPAL fares please visit the [OPAL fares and payments website](#).

GETTING TO THE PROPOSED DEVELOPMENT

PUBLIC BUS SERVICES

The proposed Residential Aged Care Facility & Independent Living Units are well connected through many public bus services shown below.

PUBLIC BUS SERVICES

Route	Destination	Frequency		
		AM Peak ⁽¹⁾	Off-Peak ⁽²⁾	PM Peak ⁽³⁾
243	City Wynyard to Spit Junction via North Cremorne	1 hour	30 minutes	1 hour
	Spit Junction to Neutral Bay and City Wynyard via North Cremorne	12 minutes	1 hour	1 hour
100	Taronga Zoo to City QVB	<10 minutes	10 minutes	<10 minutes
114	Royal North Shore Hospital to Balmoral	20 minutes	20 minutes	30 minutes
	Balmoral to Royal North Shore Hospital	10 minutes	20 minutes	12 minutes
144	Chatswood to Manly via St Leonards	12 minutes	10 minutes	10 minutes
	Manly to Chatswood via St Leonards	12 minutes	10 minutes	<10 minutes
144N	North Sydney to Manly (Night Service)	(4)	(4)	(4)
	Manly to North Sydney (Night Service)	(4)	(4)	(4)
150X	Milsons Point to Manly (Express Service)	(4)	(4)	20 minutes
	Manly to Milsons Point (Express Service)	<10 minutes	(4)	(4)
165X	City Wynyard to South Curl Curl (Express Service)	(4)	(4)	15 minutes
	South Curl Curl to City Wynyard (Express Service)	10 minutes	(4)	(4)
170X	City Wynyard to Manly (Express Service)	(4)	(4)	10 minutes
	Manly to City Wynyard (Express Service)	10 minutes	(4)	(4)
172X	City Wynyard to Warringah Mall via North Balgowlah (Express Service)	30 minutes	1 hour	20 minutes
	Warringah Mall to City Wynyard via North Balgowlah (Express Service)	15 minutes	1 hour	20 minutes
173X	City Wynyard to Warringah Mall via Balgowlah Shops (Express Service)	20 minutes	20 minutes	20 minutes
	Warringah Mall to City Wynyard via Balgowlah Shops (Express Service)	30 minutes	20 minutes	20 minutes
174X	City Wynyard to Narrabeena (Express Service)	(4)	(4)	20 minutes
	Narrabeena to City Wynyard (Express Service)	15 minutes	(4)	(4)
176X	City Wynyard to Dee Why via North Curl Curl (Express Service)	(4)	(4)	30 minutes
	Dee Why to City Wynyard via North Curl Curl (Express Service)	12 minutes	(4)	(4)
177X	City Wynyard to Dee Why via Wingala (Express Service)	(4)	(4)	1 hour
	Dee Why to City Wynyard via Wingala (Express Service)	10 minutes	(4)	(4)

228	Milsons Point to Clifton Gardens	(4)	(4)	1 hour
	Clifton Gardens to Milsons Point	1 hour	(4)	(4)
229	Milsons Point to Beauty Point via Balmoral Heights	(4)	(4)	(4)
	Beauty Point to Milsons Point via Balmoral Heights	(4)	1 hour	(4)
230	Milsons Point to Mosman Wharf via North Sydney	12 minutes	15 minutes	12 minutes
	Mosman Wharf to Milsons Point via North Sydney	<10 minutes	20 minutes	15 minutes
246	City Wynyard to Balmoral Heights	(4)	(4)	10 minutes
	Balmoral Heights to City Wynyard	<10 minutes	(4)	(4)
249	City Wynyard to Beauty Point	(4)	(4)	1 hour
	Beauty Point to City Wynyard	20 minutes	(4)	(4)

NOTE:

- (1) AM peak period – 7:00_{AM} to 8:00_{AM};
- (2) Off-peak period – 12:00_{PM} to 1:00_{PM};
- (3) PM peak period – 4:00_{PM} to 5:00_{PM};
- (4) Does not operate during the given period.

The relevant bus operator maps can be found on the [Transport Website](#). A map is provided below detailing convenient walking routes to the nearest bus stops.

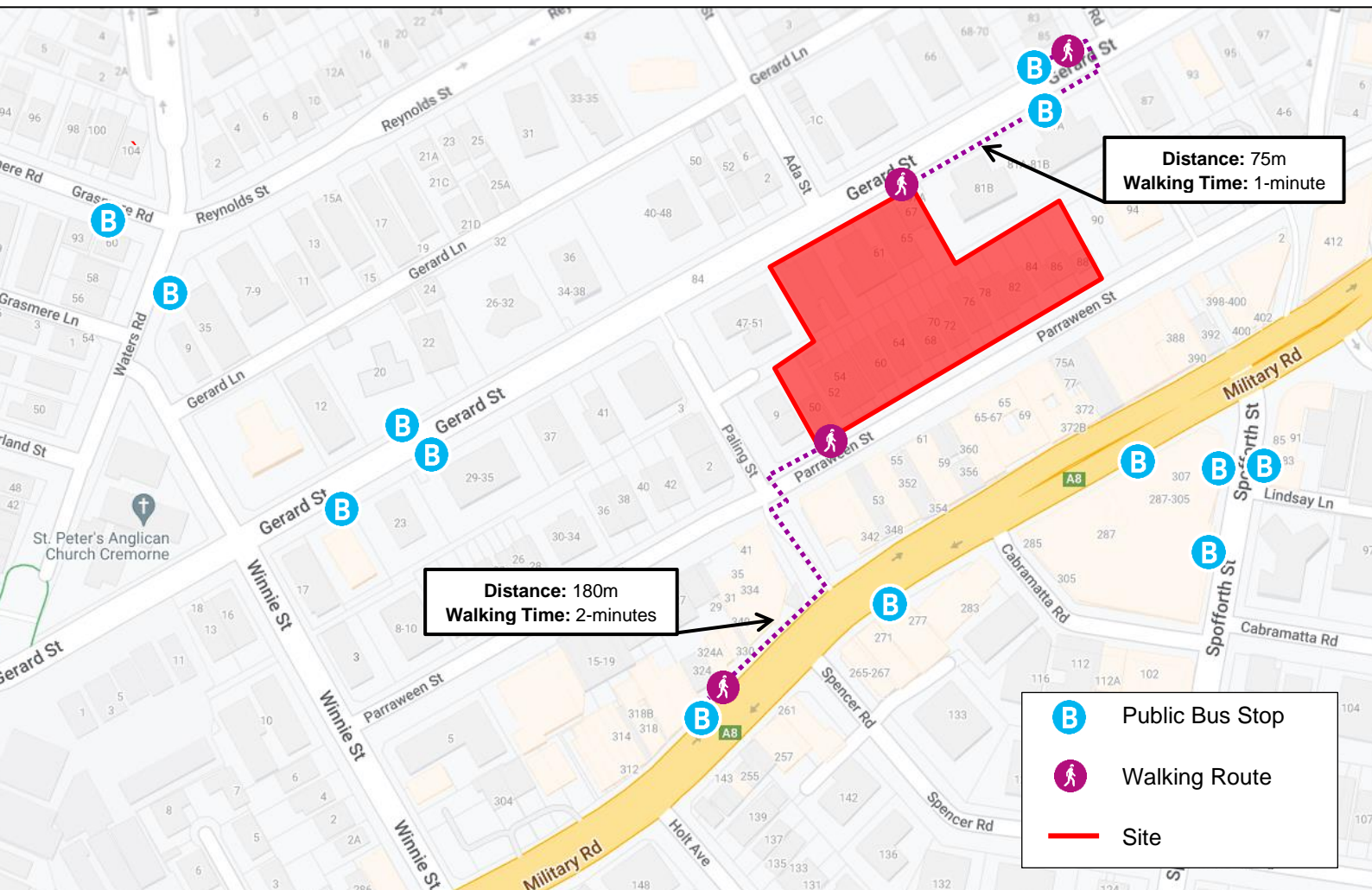

TRAIN FACILITIES

The bus services provides connection between the proposed site and Wynyard Station, North Sydney Station, Milsons Point Station, St Leonards Station and Chatswood Station.

CYCLING FACILITIES

North Sydney Council's *Cycling Guide + Map* offers cycling routes within close proximity of the proposed development. Using these marked cycle routes can give you confidence when travelling to and/or from the centre using a bicycle.

Cyclists can travel to/from the north via Military Road/ Brightmore Street which are graded as "high current bicycle use", to/ from the east via Brightmore Street which is graded as "marked on-road bicycle route" and to/from the west via the Pacific Highway which is graded as "high current bicycle use" or via Brightmore Street which is graded as "marked on-road bicycle route" and segments marked as "high current bicycle use". An extract from Northern Sydney Cycling Guide + Map is shown below.

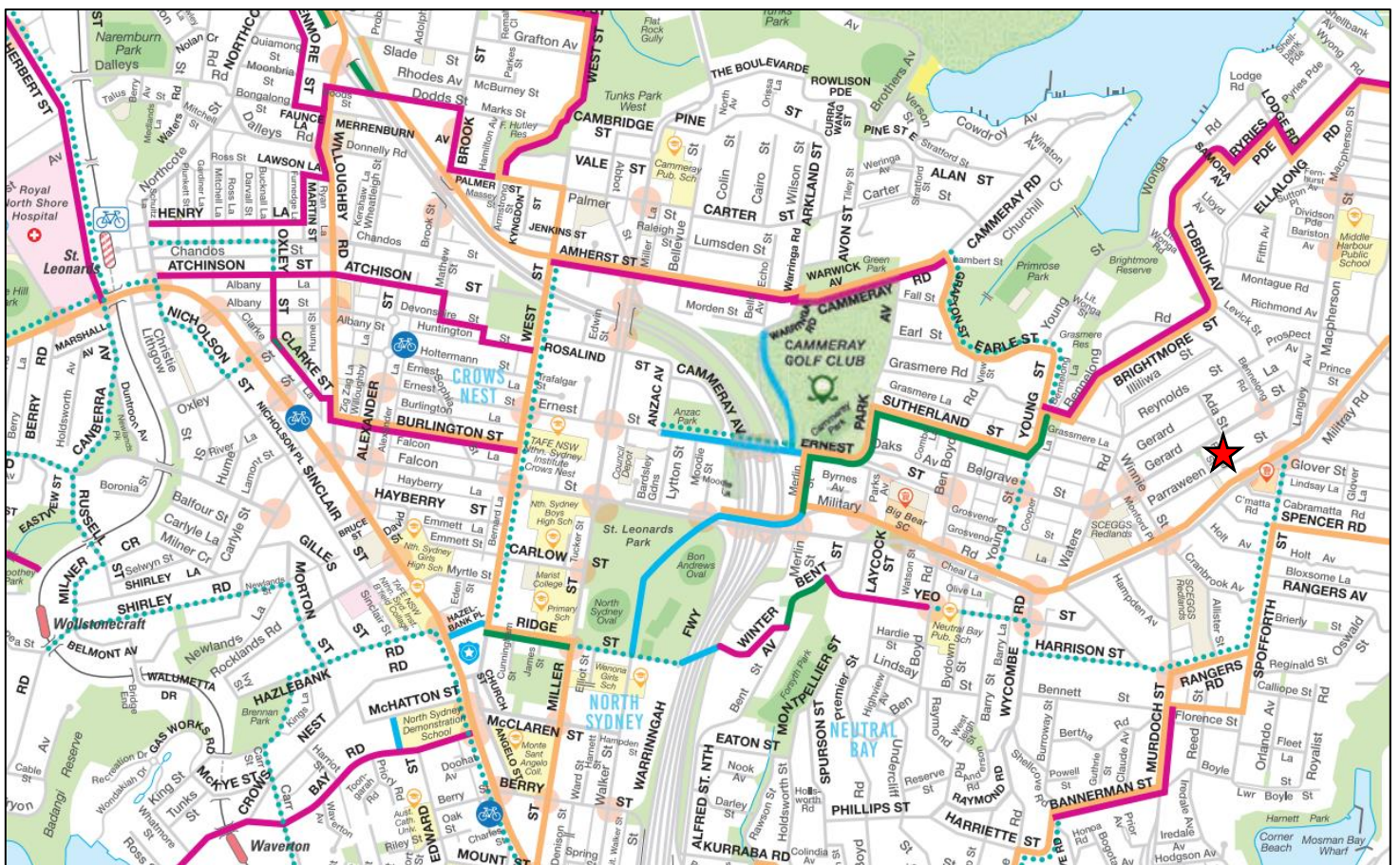

 Site Location



**ANNEXURE B: NORTH SYDNEY CYCLING MAP
(2 SHEETS)**

Northern Sydney Cycling Guide + Map

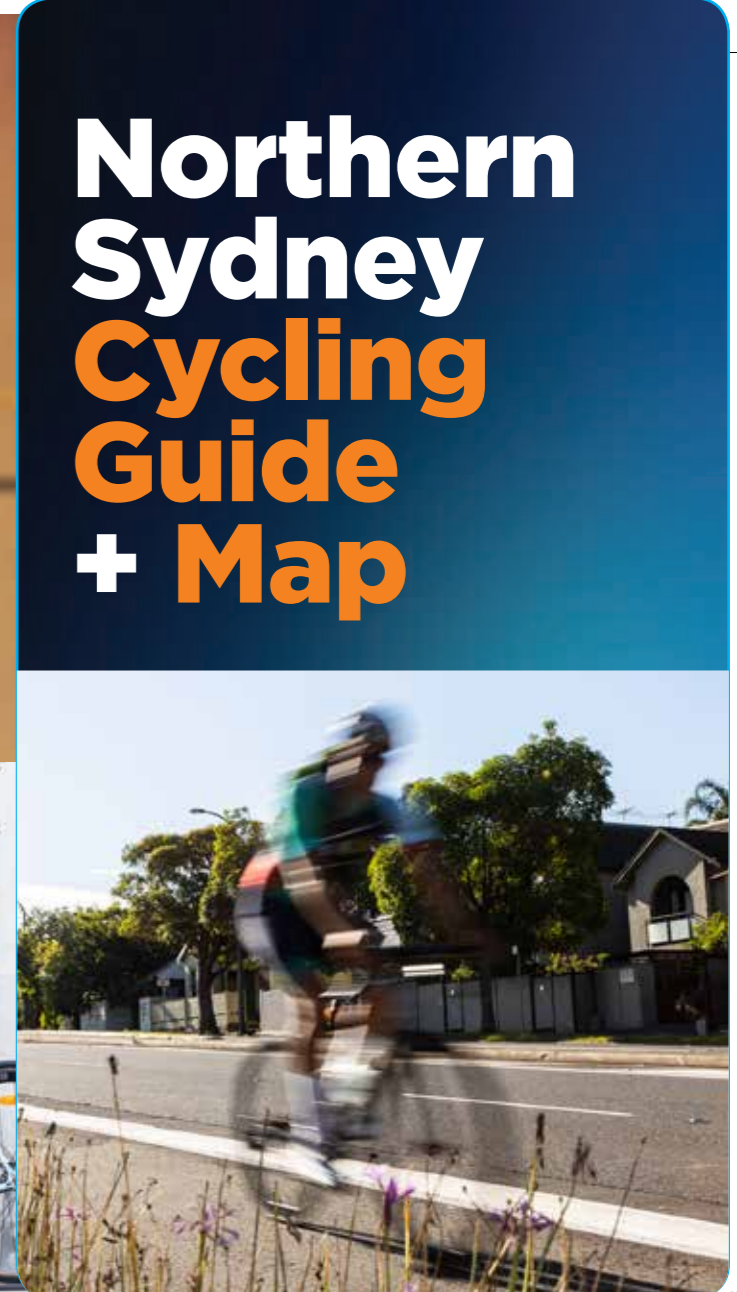

Tips for the Ride

- On shared paths, people walking have right of way
- Stop your bike on the diamonds to activate the lights
- Children 16 and under can ride on the footpath
- Use a white head light and red taillight at night
- Use a bell to signal presence
- Helmets are compulsory in NSW

Legend

- Separated Bicycle Path
- Shared User Path
- Marked On-road Bicycle Route
- High Current Bicycle Use (may include difficult conditions if separated paths are not provided)

Potential Future Bicycle Routes

Potential Future Bicycle Routes are subject to change pending further investigation. Current conditions will vary in difficulty.

Bicycle Hand Signals

Making Turns

LEFT

RIGHT

STOP



Need for more maps?

Request extra copies for your business, workplace or school at the following Councils

Lane Cove Council
 02_9911 3555
www.lanecove.nsw.gov.au
lccouncil@lanecove.nsw.gov.au

North Sydney Council
 02_9936 8100
www.northsydney.nsw.gov.au
council@northsydney.nsw.gov.au

Willoughby City Council
 02_9777 1000
www.willoughby.nsw.gov.au
email@willoughby.nsw.gov.au

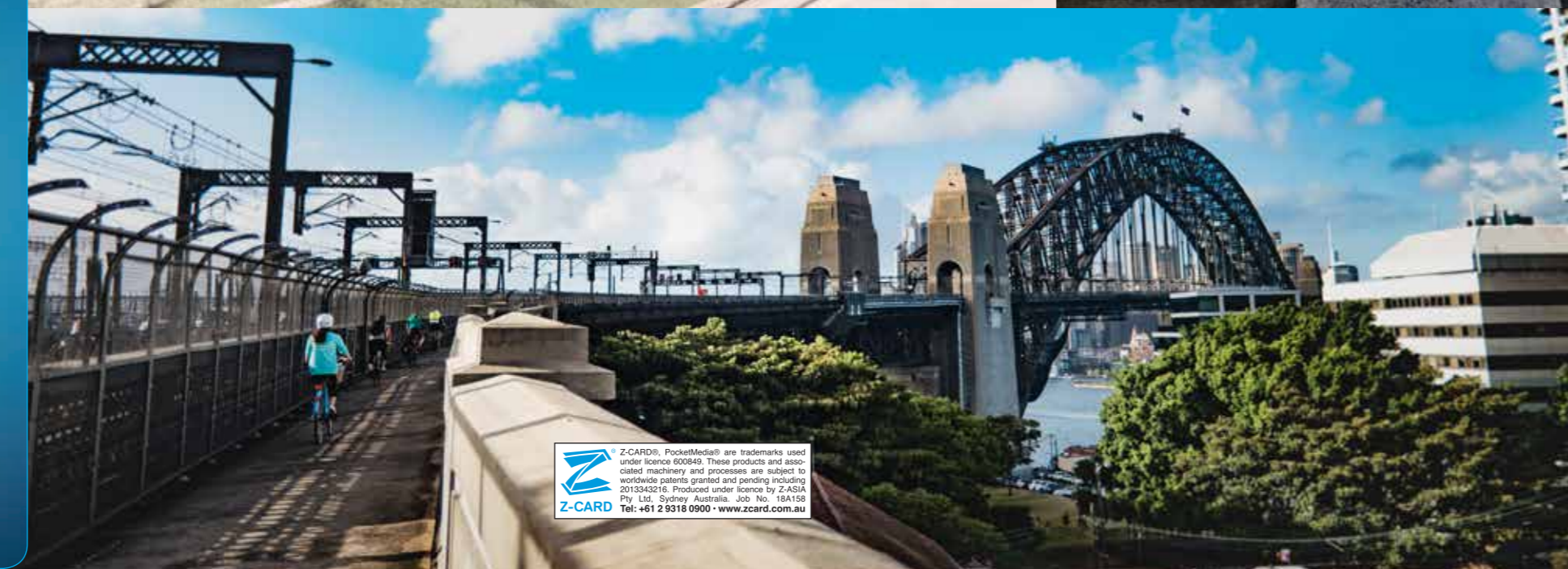
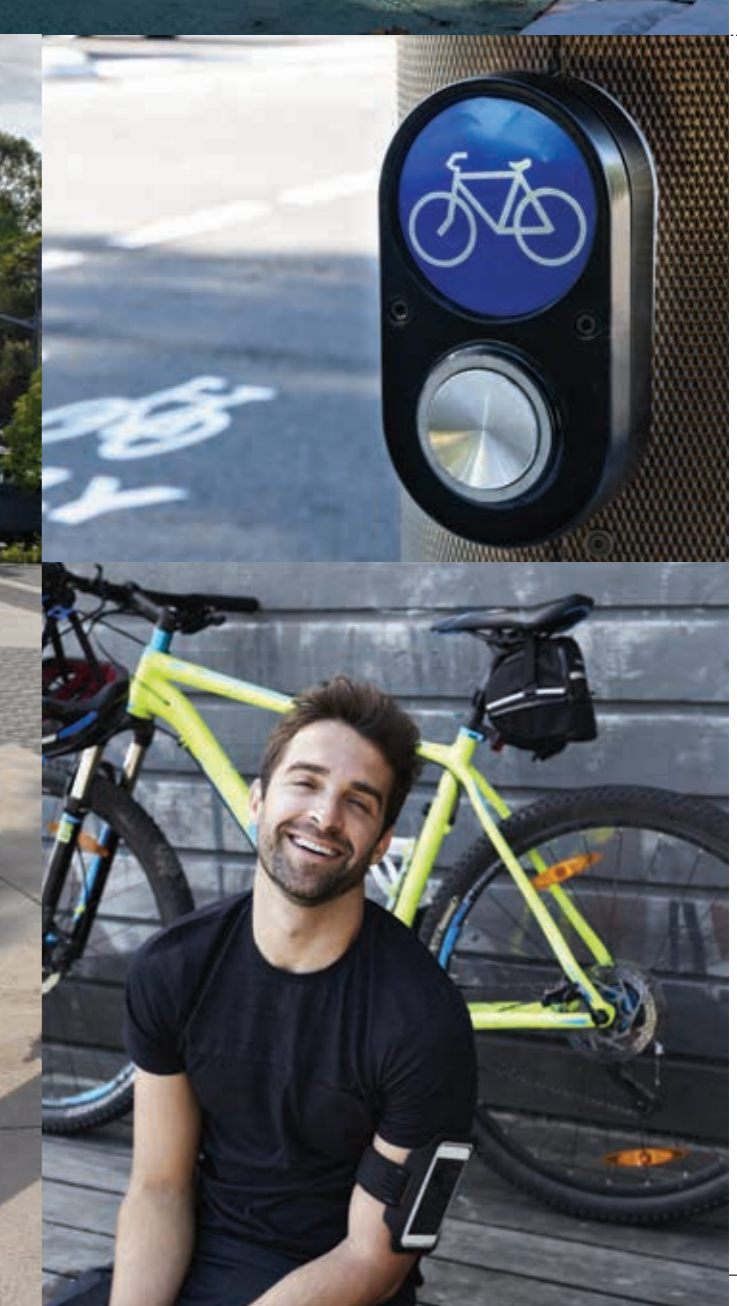

Z-CARD®. ProctorMedia® are trademarks used under licence 000880. These products and associated machinery and processes are subject to worldwide patents granted and pending including 2013/242016. Produced under licence by Z-CARD® Pty Ltd. Sydney Australia. Tel: +61 2 9318 0900 - www.zcard.com.au

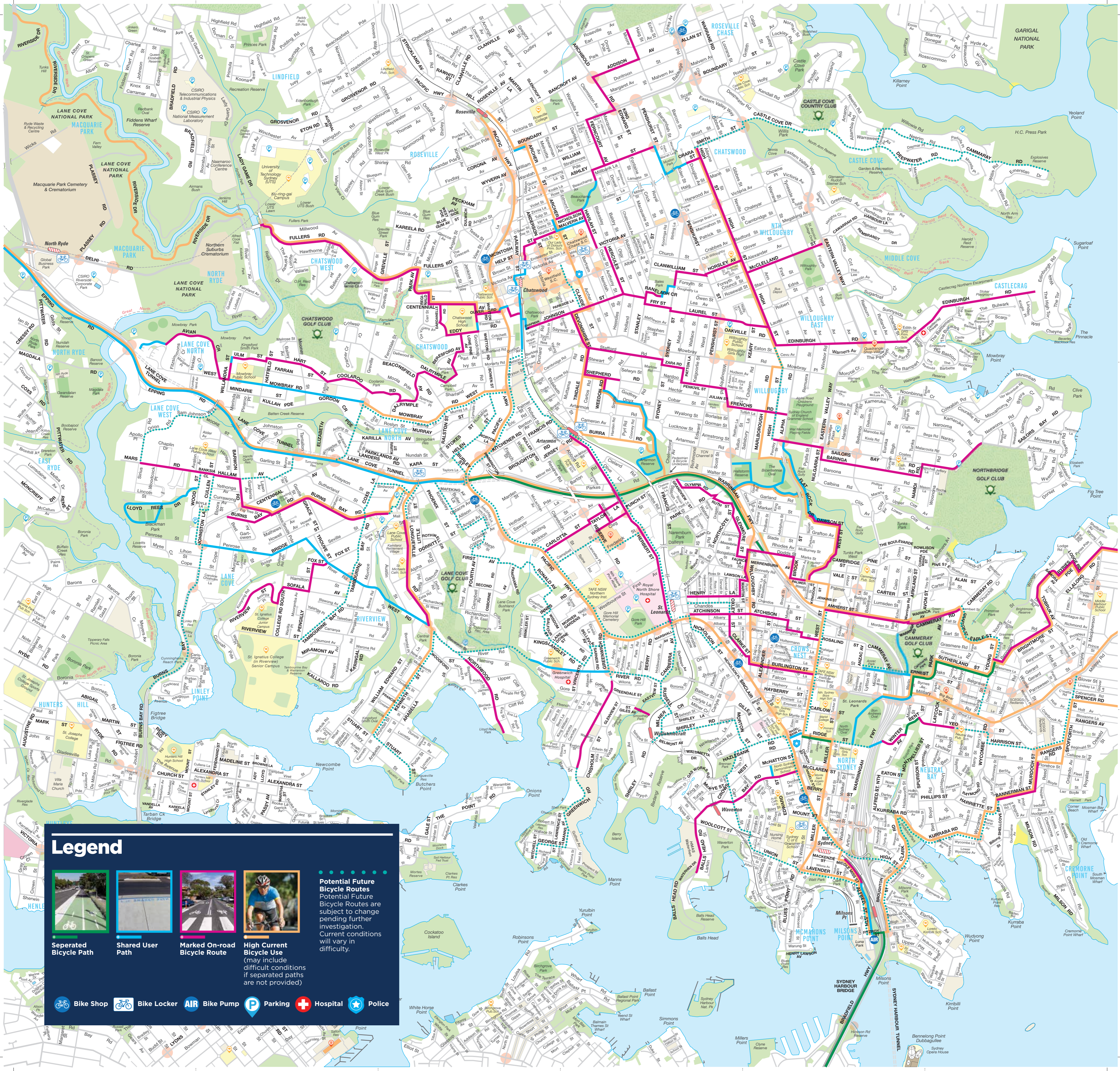

Legend



Separated Bicycle Path
Shared User Path
Marked On-road Bicycle Route
High Current Bicycle Use (may include difficult conditions if separated paths are not provided)

Potential Future Bicycle Routes
 Potential Future Bicycle Routes are subject to change pending further investigation. Current conditions will vary in difficulty.

- Bike Shop
- Bike Locker
- Air Bike Pump
- Parking
- Hospital
- Police



**ANNEXURE C: TRAVEL MODE SURVEYS
(2 SHEETS)**

Staff Travel Mode Survey

Summary of Questions for Reference ONLY

When did you start work today?

(Please get accurate answers to the nearest minute)

How did you arrive to work today?

- I drove in my own car
- I carpoled with another worker
- I was dropped-off by family, friends or similar?
- I used a ride share company (Uber, Taxi etc)
- I caught the Bus
- I caught the Train and then the Bus
- I walked
- I cycled
- Other – Please specify

When do you finish work today?

(Please get accurate answers to the nearest minute)

How will you leave work today?

- I drove in my own car
- I carpoled with another worker
- I was dropped-off by family, friends or similar?
- I used a ride share company (Uber, Taxi etc)
- I caught the Bus
- I caught the Train and then the Bus
- I walked
- I cycled
- Other – Please specify

If you drove to work, where did you park your car?

- On-site (in on-site staff parking)
- On-street – please specify which street.

Roughly, how far away from the workplace do you live?

- Roughly a 10min walk or less?
- Roughly a 20min walk or less?
- More than a 20min walk from the site?

Staff Travel Mode Survey

Day: Monday / Tuesday / Wednesday / Thursday / Friday (Please Circle)

Date: _____

Respondent	When did you start work today?	How did you arrive to work today?	When do you finish work today?	How will you leave work today?	If you drove, where did you park your car?	Roughly, how far away (in walking time) from the work place do you live? (<10min, 10-20min, OR >20min Walk)
1						
2						
3						
4						
5						
6						
7						
8						
9						
10						
11						
12						
13						
14						
15						
16						



**ANNEXURE E: SWEEP PATH TESTING
(11 SHEETS)**

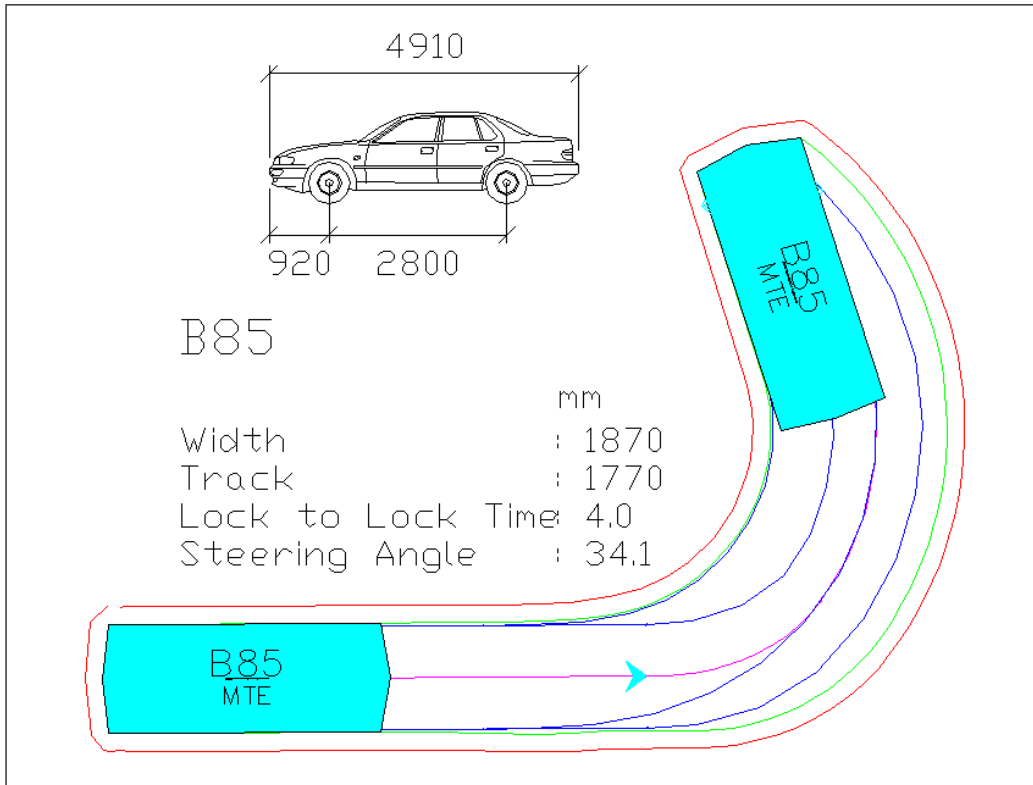

AUSTRALIAN STANDARD 85TH PERCENTILE SIZE VEHICLE (B85)

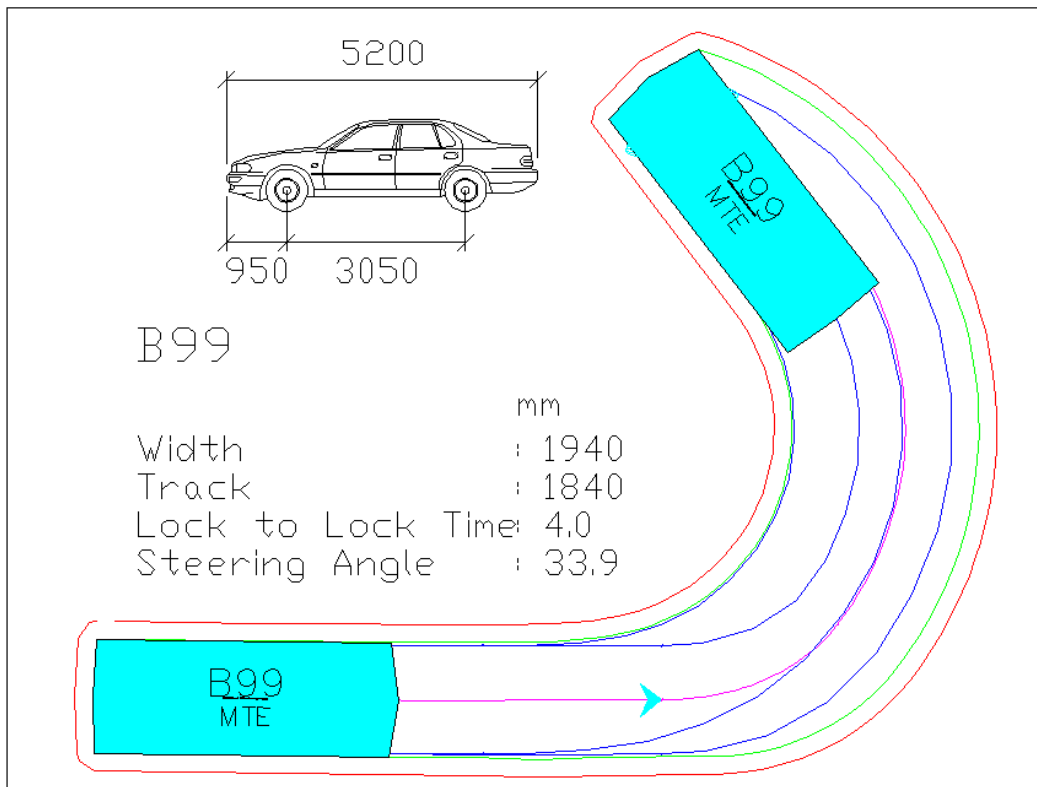

AUSTRALIAN STANDARD 99.8TH PERCENTILE SIZE VEHICLE (B99)

Blue – Tyre Path
Green – Vehicle Body
Red – 300mm Clearance

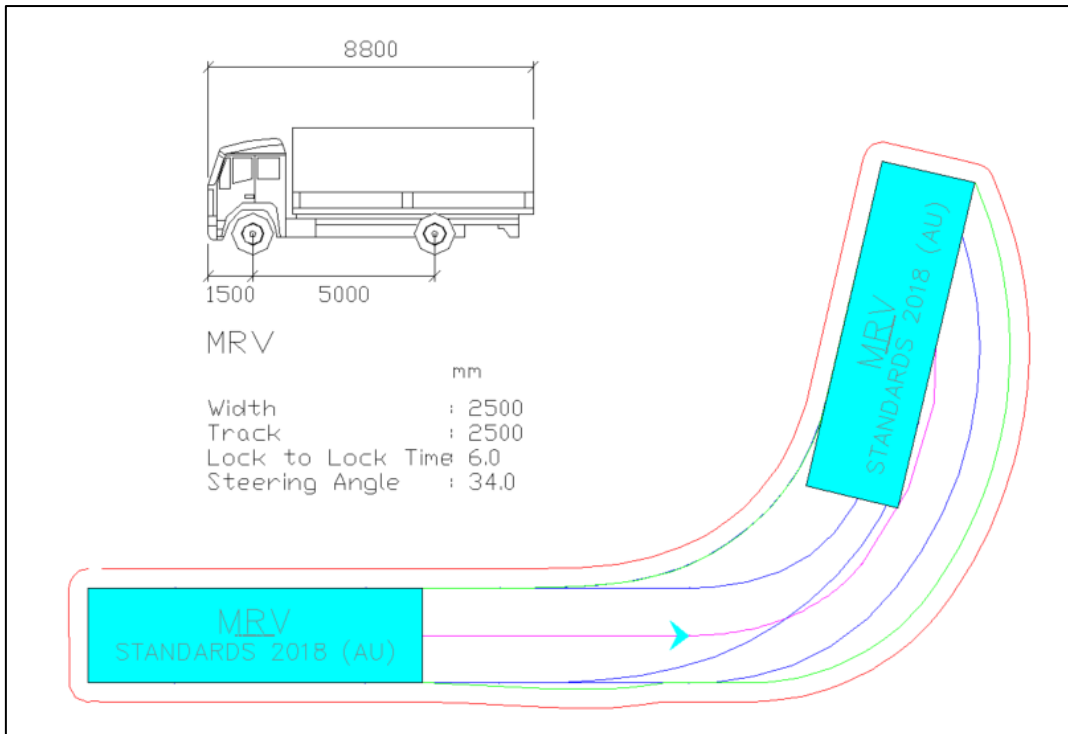

AUSTRALIAN STANDARD MEDIUM RIGID VEHICLE (MRV)

- Blue – Tyre Path
- Green – Vehicle Body
- Red – 500mm Clearance

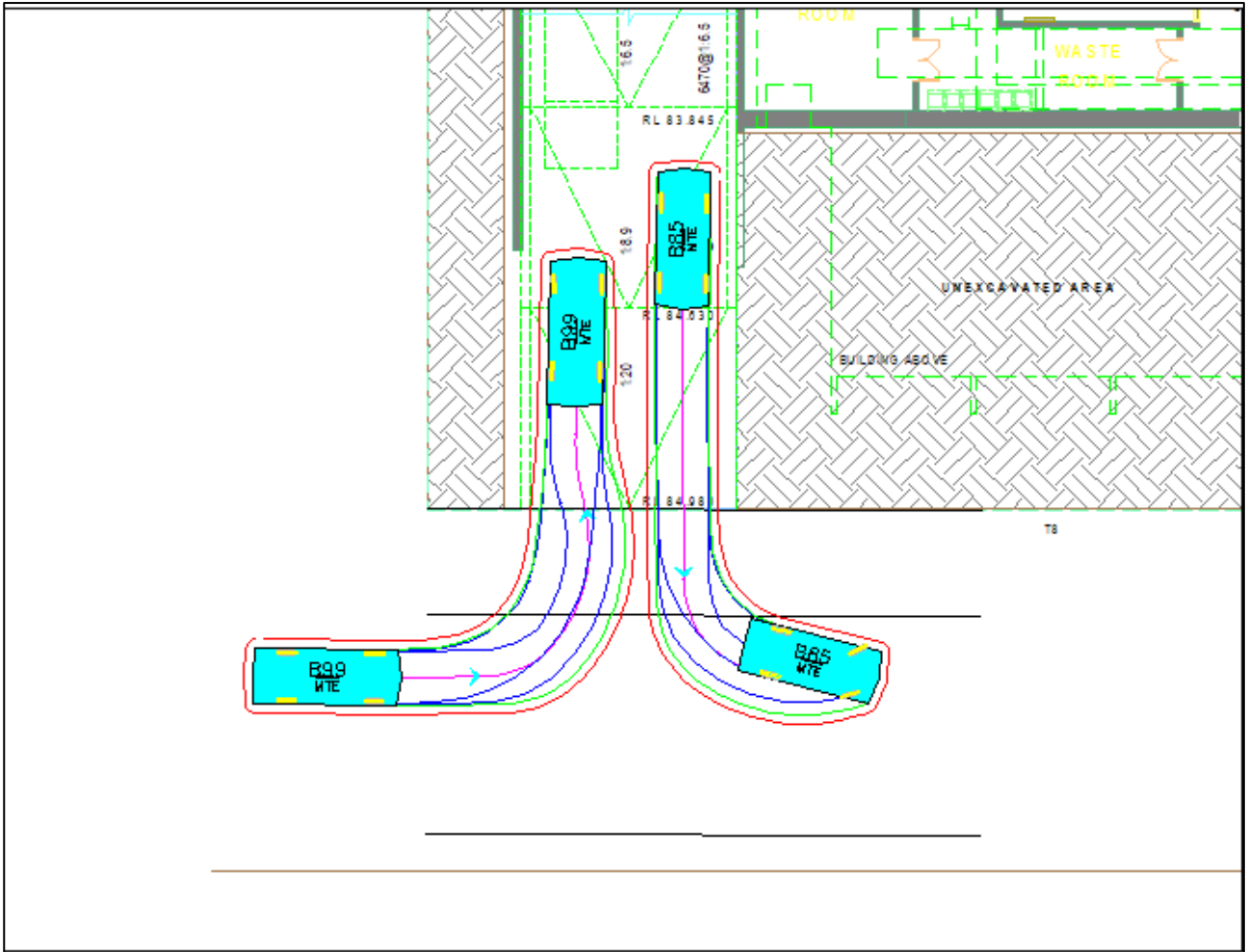

B99 passing B85 at the site driveway

Tested @ 5km/h

Successful

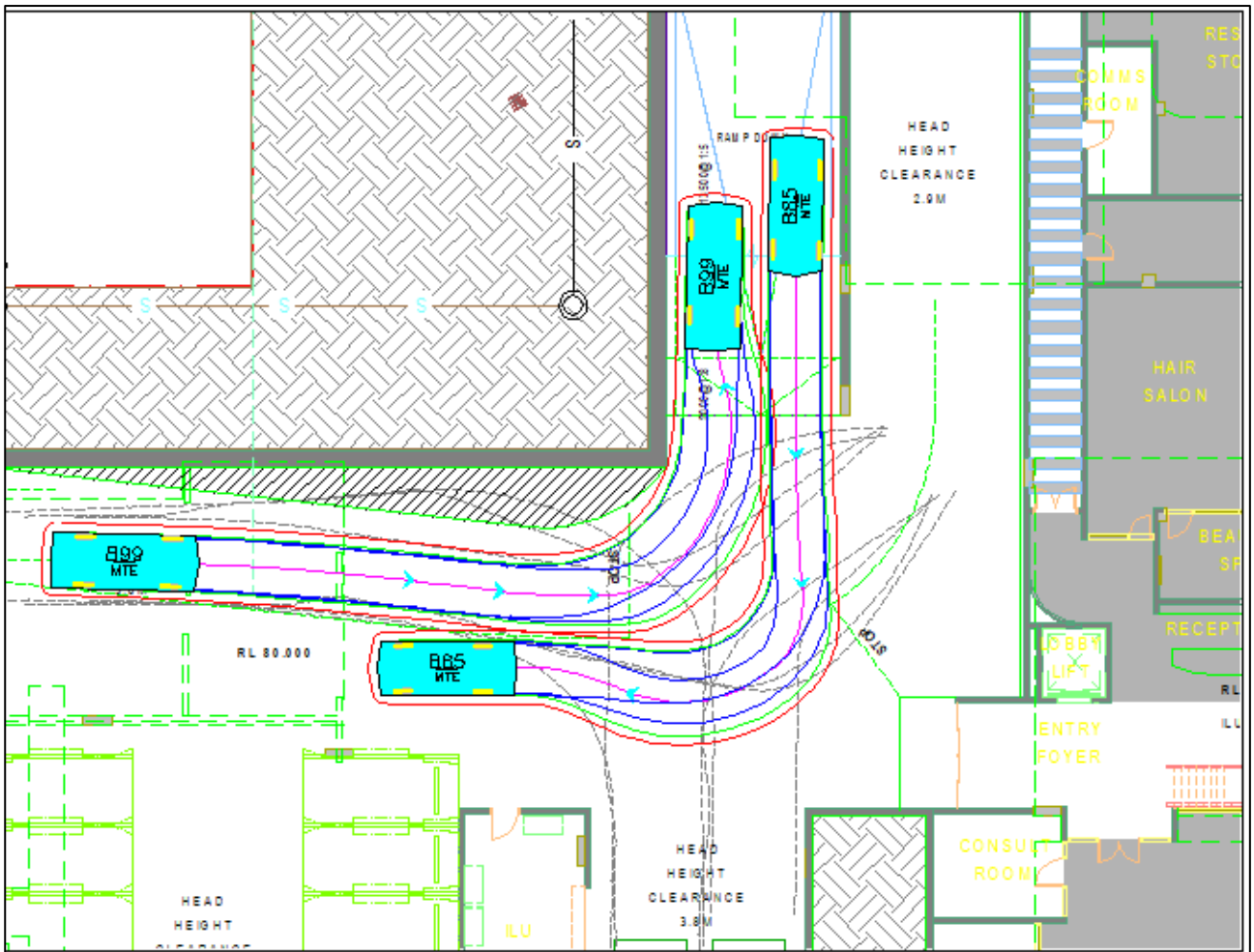

B99 passing B85 at the along the ramp

Tested @ 5km/h

Successful – Intervisibility between passing areas is provided

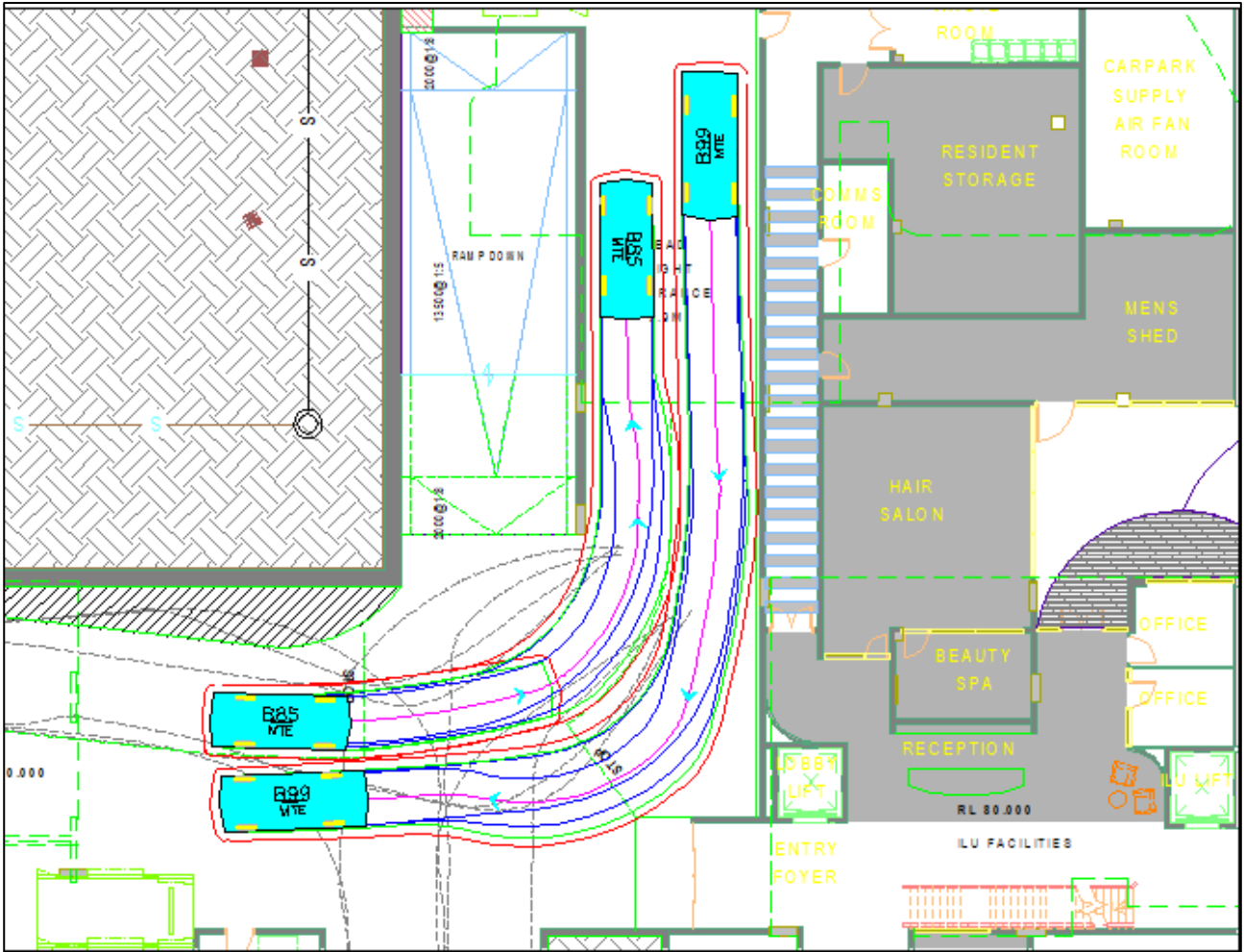

B99 passing B85 at the along circulation roadway

Tested @ 5km/h

Successful

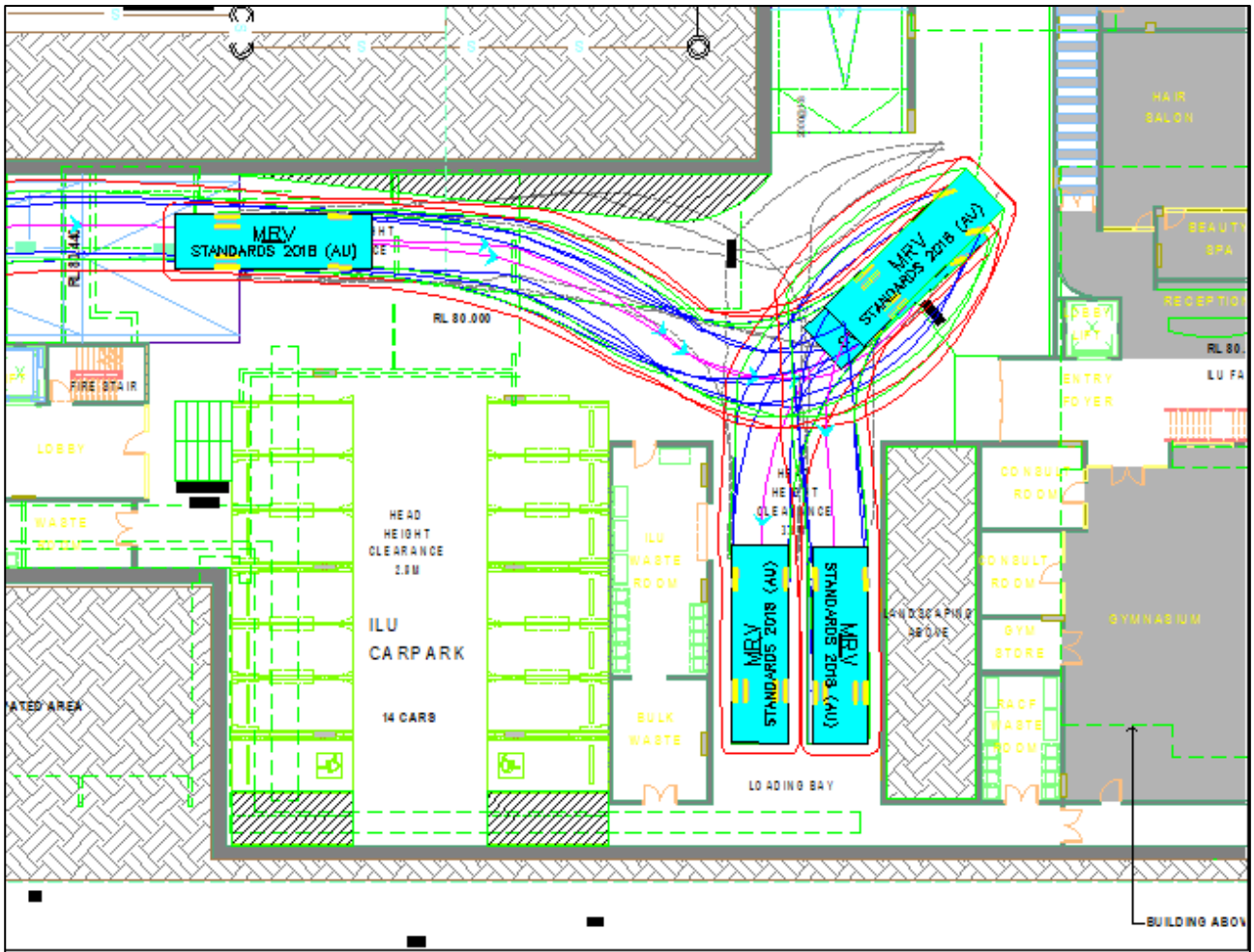

8.8m length MRV reverse entry into both spaces

Tested @ 5km/h

Successful

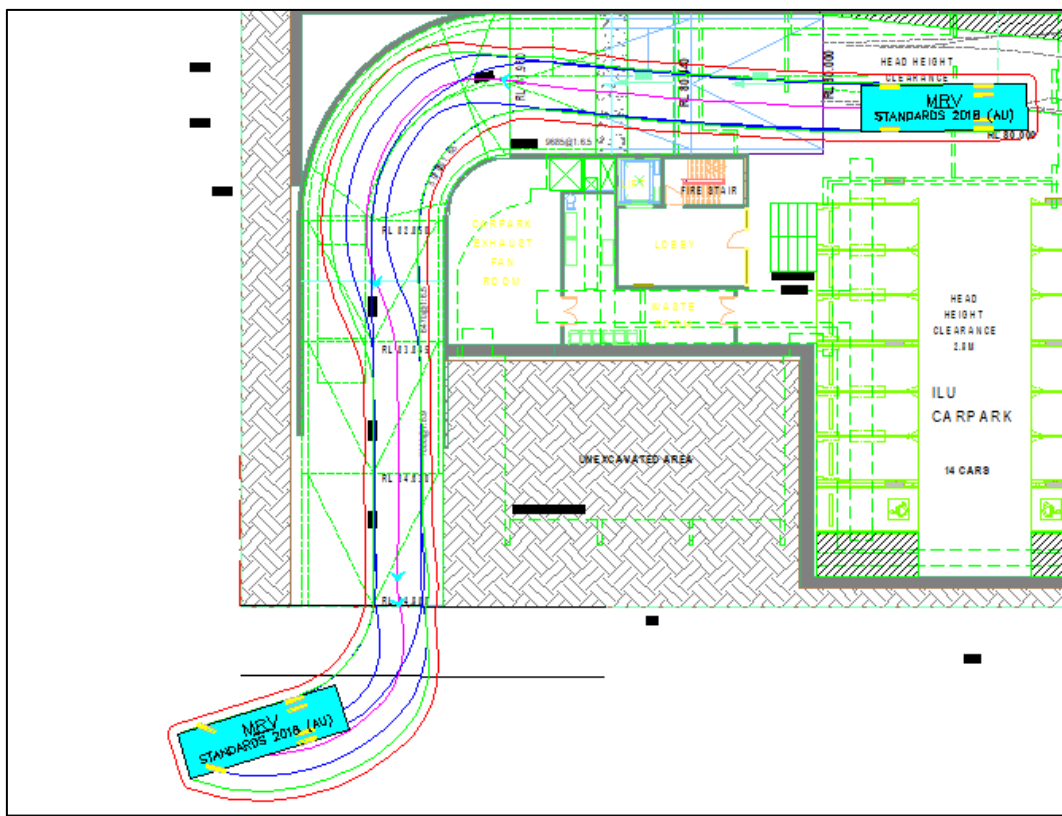
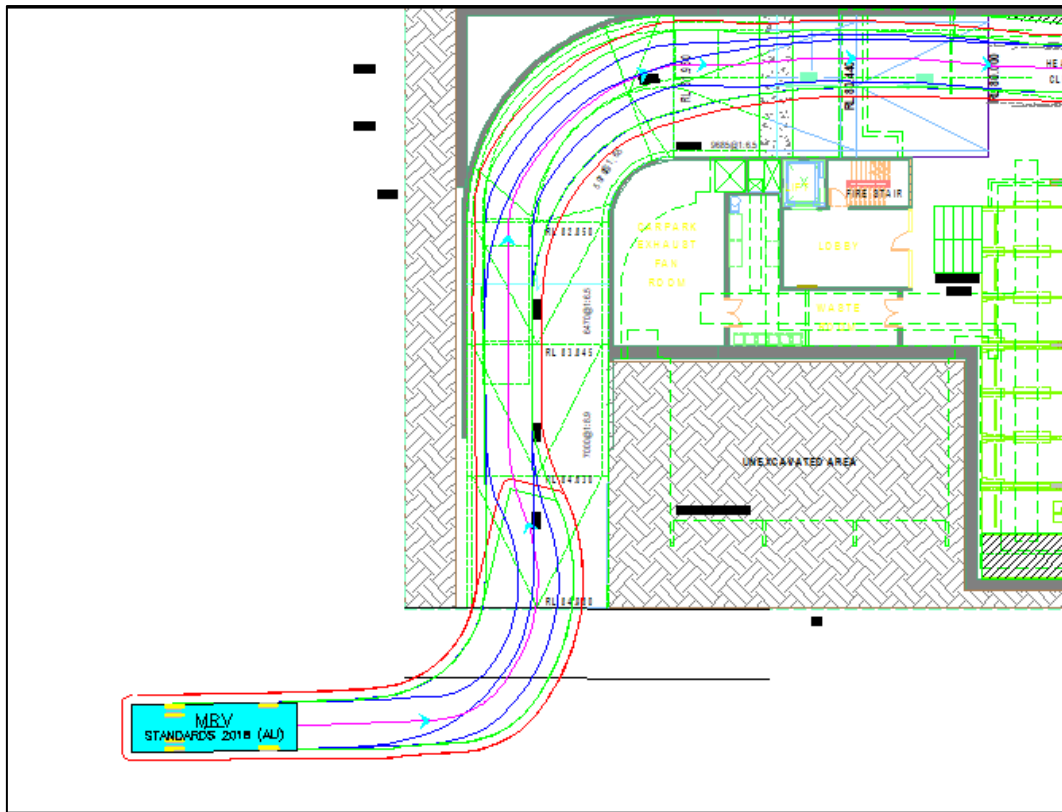

8.8m length MRV entry and exit from site

Tested @ 5km/h

Successful

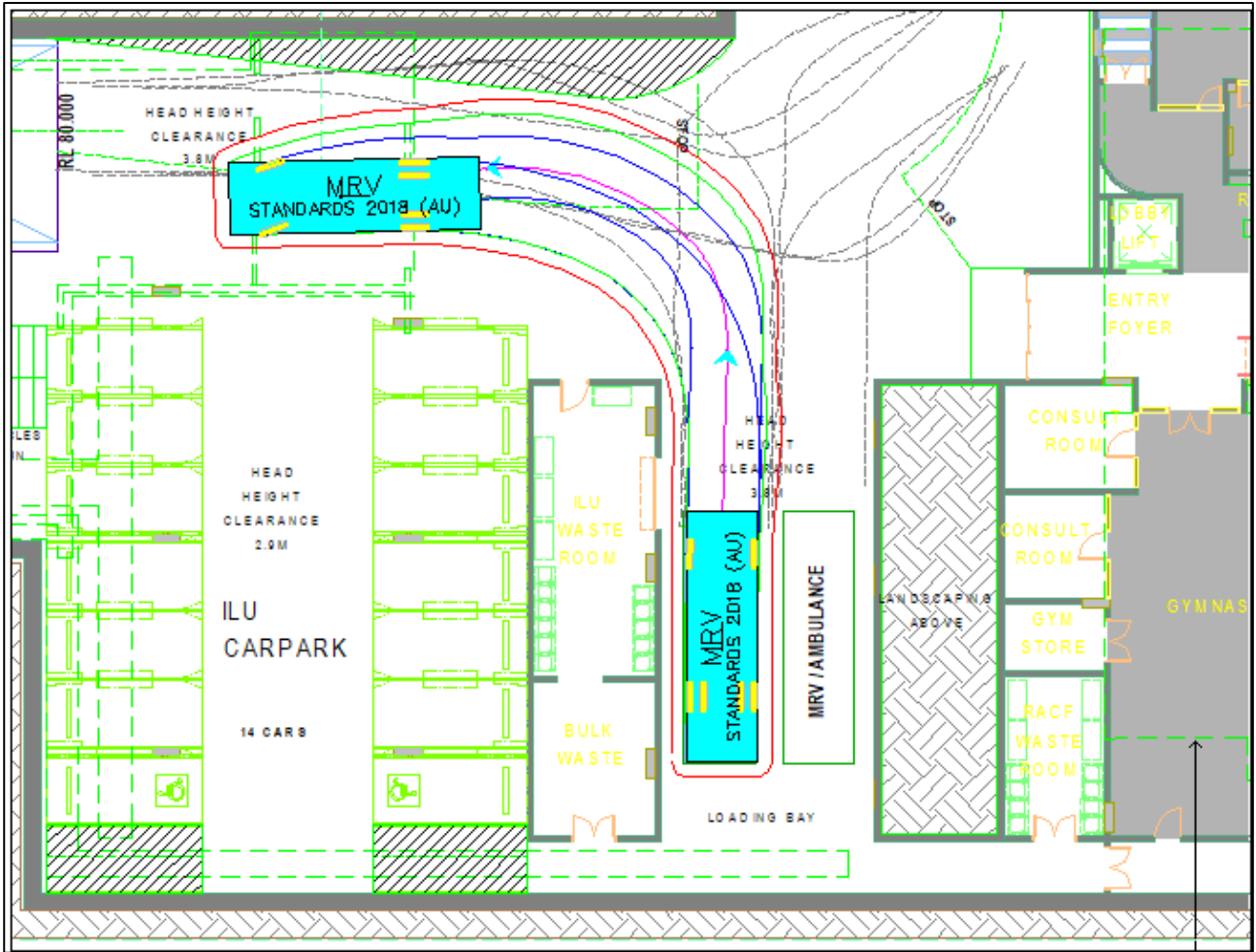

8.8m length MRV exit from inside space

Tested @ 5km/h

Successful

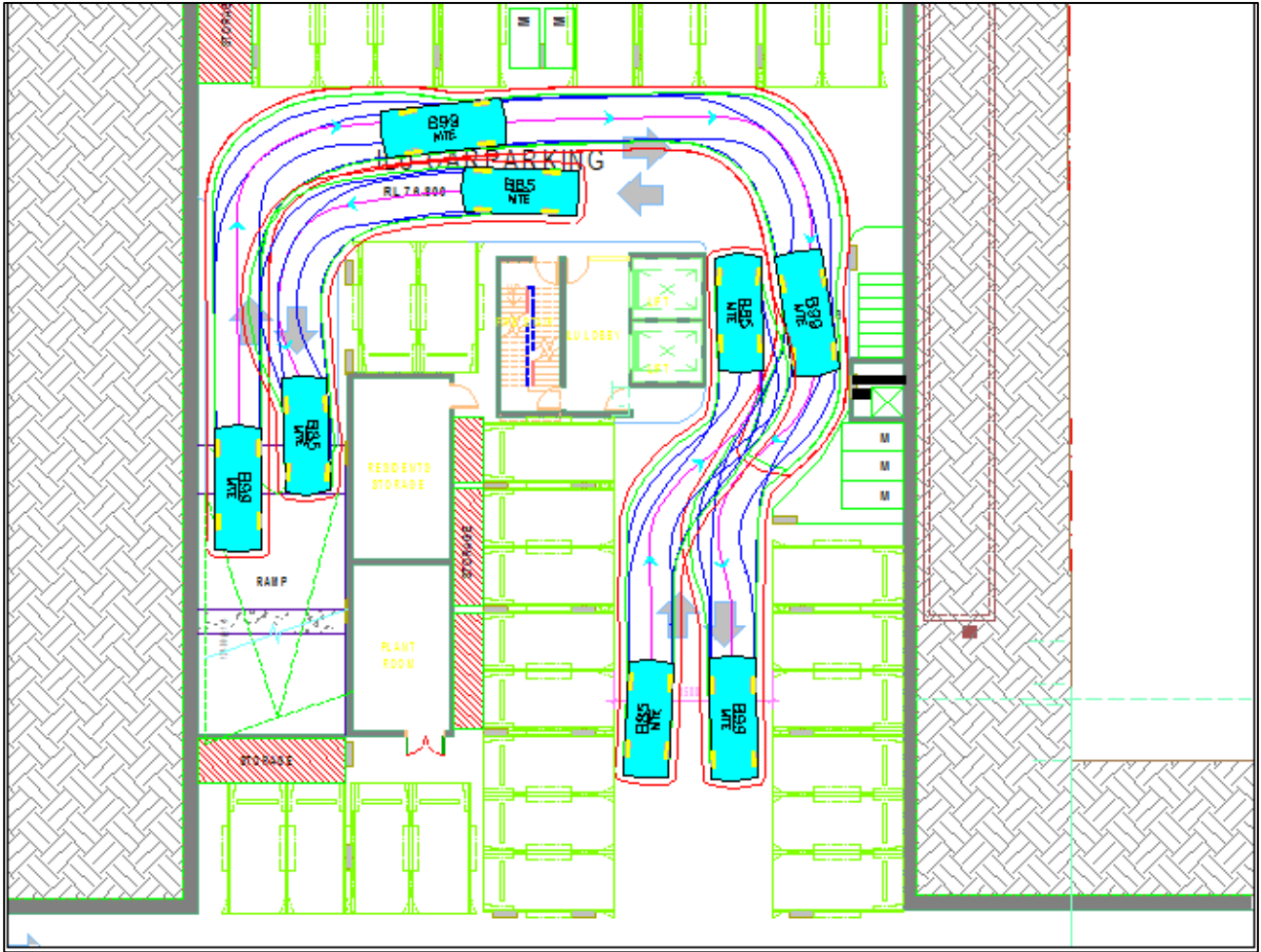

B99 and B85 passing in Basement

Tested @ 5km/h

Successful – Intervisibility is provided between passing areas

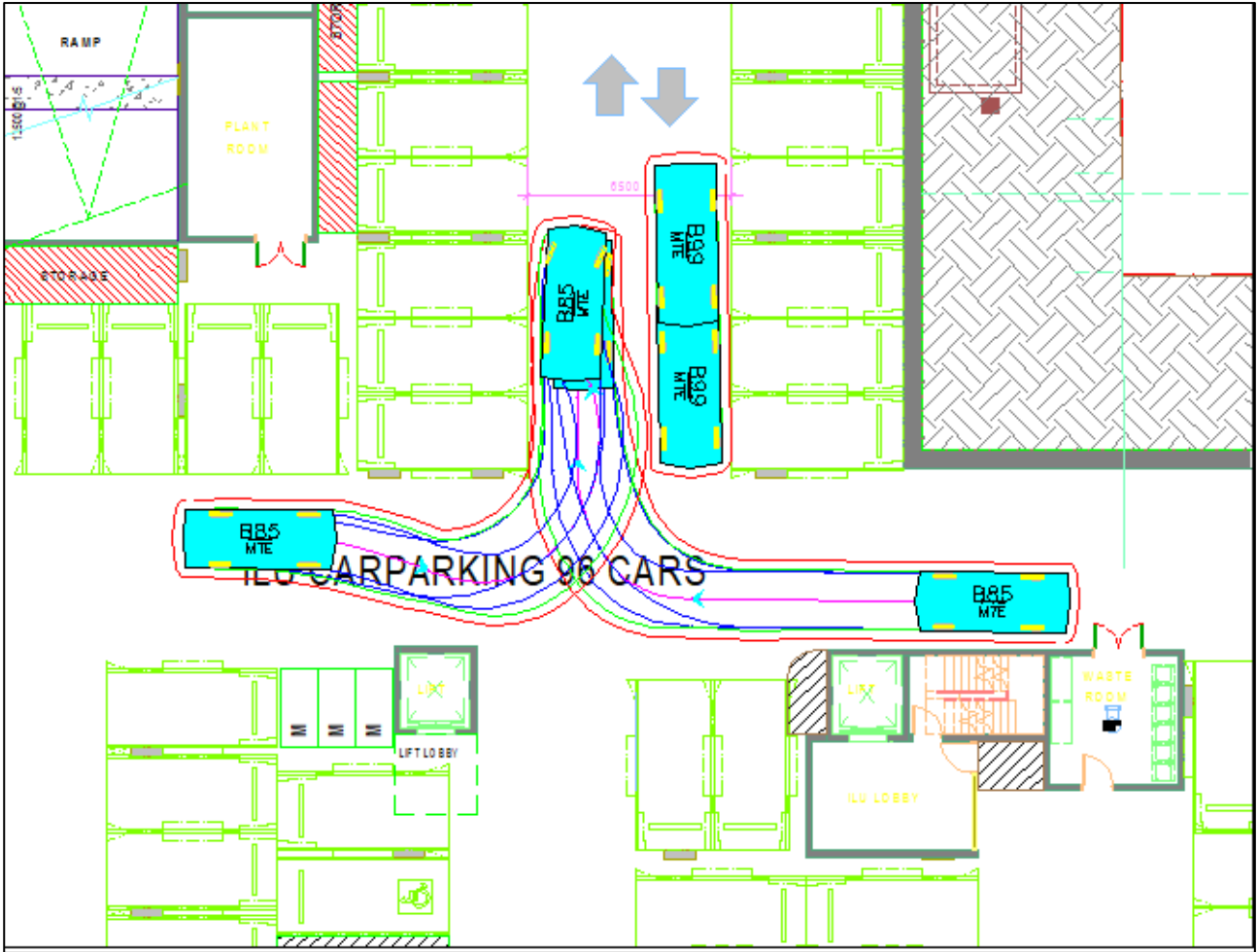

B99 & B85 passing in basement car park

Tested @ 5km/h

Successful