

LEGEND

	DENOTES R.A.P. (A.C.M. REMEDIATION) SUB-STAGE 1
	DENOTES R.A.P. (A.C.M. REMEDIATION) SUB-STAGE 2

SOIL AND WATER MANAGEMENT OVERALL STAGING PLAN

SCALE 1:500

NOT FOR CONSTRUCTION

SECTION 4.55 MODIFICATION "MOD 2" NOTES
 CHANGES TO THE CIVIL DRAWINGS FOR "MOD 2" GENERALLY COMPRISE THE FOLLOWING:
 • COORDINATION WITH AMENDED GENERAL ARCHITECTURAL ARRANGEMENT

DRAWING TO BE PRINTED IN COLOUR

6	REVISED DEVELOPMENT APPLICATION - MOD 2	3.12.25	© Copyright MPC Consulting Engineers as date of issue		COPYRIGHT		 <p>Level 1, 16 Telford Street, NEWCASTLE EAST, NSW 2300 PO BOX 871 NEWCASTLE, NSW 2300 Tel: (02) 4927 5566 Email: admin@mpceng.com.au Web: www.mpceng.com.au A.C.N. 670 257 315</p>	CLIENT	PROJECT	DO NOT SCALE DRAWING		
5	REVISED DEVELOPMENT APPLICATION - MOD 1	3.9.25	THIS DRAWING IS NOT TO BE USED FOR CONSTRUCTION UNLESS ENDORSED BELOW		<p>The concepts and information contained in this document are the copyright of MPC Consulting Engineers. Use or copying of the document in whole or in part without the written permission of MPC Consulting Engineers constitutes an infringement of copyright.</p>			UNITING	PROPOSED UNITING DEVELOPMENT AT; LOT 223, DP 551260, No.27 TIRAL STREET, CHARLESTOWN	DRAWN J.D.L.	ENGINEER B.C.	No in SET -
4	REVISED DEVELOPMENT APPLICATION	25.8.22					TITLE		SCALES	JOB No 200243	DRAWING No 00100	ISSUE 6
3	DEVELOPMENT APPLICATION	19.8.22					SOIL AND WATER MANAGEMENT OVERALL STAGING PLAN		1:500			
2	PRELIMINARY DEVELOPMENT APPLICATION	12.8.22										
1	COORDINATION	1.7.22										
0	80% DEVELOPMENT APPLICATION	19.11.21										
ISSUE	REASON FOR ISSUE	DATE	DATE OF RELEASE	RESPONSIBLE PRINCIPAL SIGNATURE	ISSUE							

FULL SIZE ON ORIGINAL 0 1 2 3 4 5 6 7 8 9 10 11 12 13 14 15 cm

SOIL AND WATER MANAGEMENT PLAN STAGE 1 REMEDIAL ACTION PLAN WORKS

SCALE 1:500

SEDIMENTATION, EROSION CONTROL AND STORMWATER MANAGEMENT NOTES

1. SELECTIVE CLEARING OF VEGETATION TO BE RESTRICTED TO NOMINATED AREAS WITH CLEARED VEGETATION WIND ROWED ON THE CONTOUR.
2. ALL EROSION AND SEDIMENT CONTROL MEASURES TO BE INSTALLED PRIOR TO SITE DISTURBANCE.
3. TOPSOIL FROM ALL AREAS THAT WILL BE DISTURBED TO BE STRIPPED AND STOCKPILED AT THE NOMINATED SITE.
4. NO MORE THAN 150m OF TRENCH TO BE OPEN AT ANY ONE TIME.
5. CUT AND FILL BATTER GRADIENTS OF 1:2 (MAXIMUM).
6. A STRIP OF TURF 450mm WIDE IS TO BE PLACED IMMEDIATELY BEHIND THE KERB ON ALL NEW ROAD TO ACT AS A FILTER TRAP. REFER TO DETAIL SD6-13.
7. ALL SEDIMENT CONTROL STRUCTURES TO BE INSPECTED BY SITE SUPERVISOR AFTER EACH RAINFALL EVENT FOR STRUCTURAL DAMAGE AND ALL TRAPPED SEDIMENT TO BE REMOVED TO A NOMINATED STOCKPILE SITE.
8. THE PROJECT MANAGER TO INFORM ALL CONTRACTORS AND SUB-CONTRACTORS OF THEIR OBLIGATIONS UNDER THE STORMWATER MANAGEMENT PLAN.
9. NO DISTURBED AREA IS TO REMAIN DENUDE LONGER THAN 14 DAYS, UNLESS MANAGED BY THE CONTRACTOR TO ENSURE NO RUNOFF OCCURS.
10. ALL FILLS ARE TO BE LEFT WITH A LIP AT THE TOP OF THE SLOPE AT THE END OF EACH DAY'S OPERATION.
11. THE CONTRACTOR MUST ENSURE THE SUITABILITY AND INTEGRITY OF ALL WORKS AT THE END OF EACH DAY'S WORK AND CONSIDER HOLD OR INSPECTION POINTS AS STAGES OF WORKS PROGRESS.
12. ORANGE BARRIER TAPE TO BE AFFIXED TO TOP OF SEDIMENT CONTROL BARRIER TO IDENTIFY WORK AREA.
13. ALL SEDIMENTATION & EROSION CONTROL AND STORMWATER MANAGEMENT MEASURES ARE TO STRICTLY COMPLY WITH THE GUIDELINES DETAILED IN THE DEPARTMENT OF HOUSING PUBLICATION, "MANAGING URBAN STORMWATER - SOILS AND CONSTRUCTION", 4TH EDITION.
14. WATER TRUCKS TO BE USED AS REQUIRED TO PREVENT WIND EROSION.
15. SUBGRADE MATERIAL TO BE CONSTRUCTED IMMEDIATELY FOLLOWING FILL.

LEGEND

- DENOTES CATCHMENT ZONES
- DENOTES SURFACE FLOW DIRECTION
- [Hatched Box] DENOTES ALLOWABLE AREA FOR TEMPORARY STOCKPILING OF CUT SOIL MATERIAL, REFER TO DETAIL SD4-1
- [Rock Pattern Box] DENOTES ROCK CHECK DAM, REFER TO DETAIL SD5-4
- [Dotted Box] DENOTES TEMPORARY WATERWAY CROSSING, REFER TO DETAIL SD5-1
- [Dotted Box] DENOTES TEMPORARY HAUL ROAD FOR EARTHWORKS PLANT MOVEMENTS
- ← DENOTES EARTH BANK (LOW FLOW), REFER TO DETAIL SD5-5
- ← DENOTES EARTH BANK (HIGH FLOW), REFER TO DETAIL SD5-6
- DENOTES SEDIMENT FENCE, REFER TO DETAIL SD6-8
- [Mesh Box] DENOTES MESH AND GRAVEL INLET FILTER, REFER TO DETAIL SD6-11
- [Geotextile Box] DENOTES GEOTEXTILE INLET FILTER, REFER TO DETAIL SD6-12
- [Cross-hatched Box] DENOTES STABILISED SITE ACCESS, REFER TO DETAIL SD6-14
- ↑↑ DENOTES LEVEL SPREADER

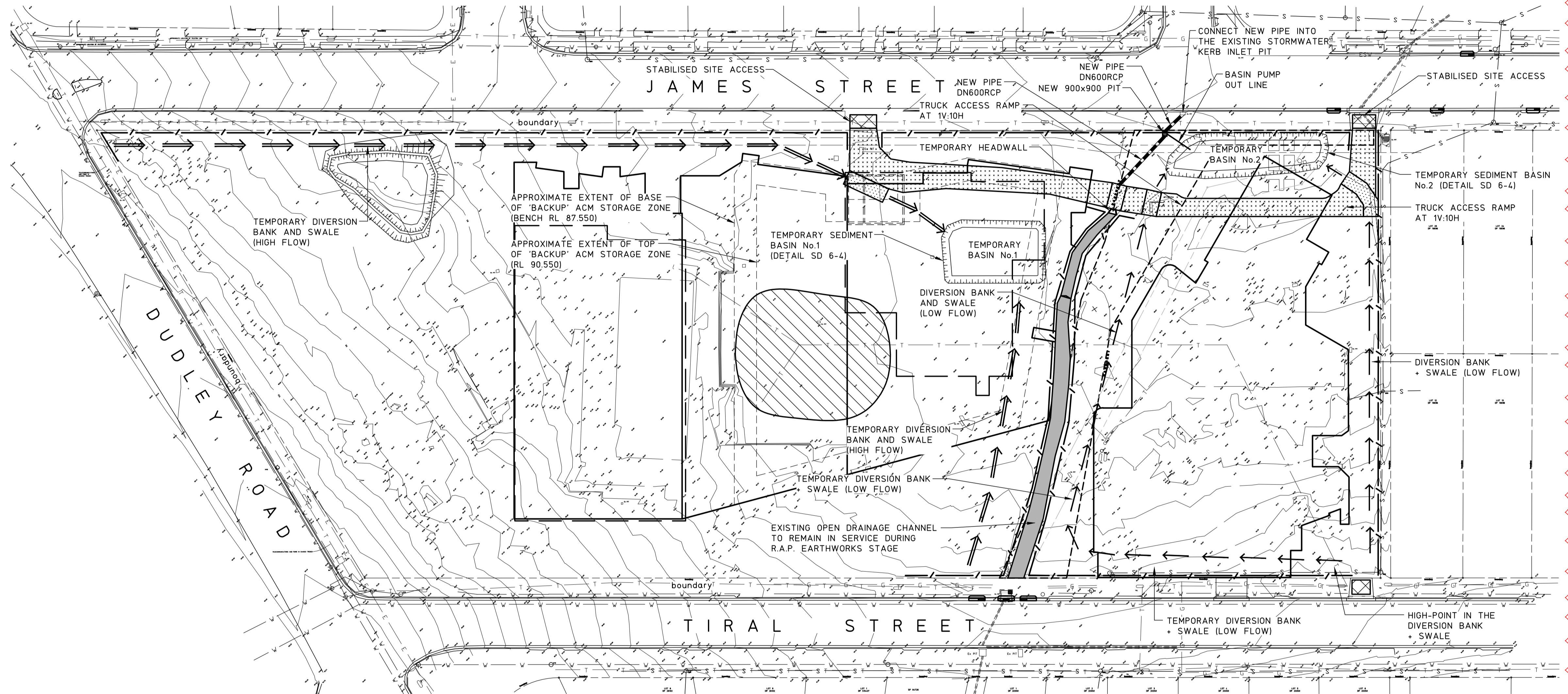

SECTION 4.55 MODIFICATION "MOD 2" NOTES
CHANGES TO THE CIVIL DRAWINGS FOR "MOD 2" GENERALLY COMPRISE THE FOLLOWING:
• COORDINATION WITH AMENDED GENERAL ARCHITECTURAL ARRANGEMENT

DRAWING TO BE PRINTED IN COLOUR

NOT FOR CONSTRUCTION

ISSUE	REASON FOR ISSUE	DATE	DATE OF RELEASE	RESPONSIBLE PRINCIPAL SIGNATURE	ISSUE
9	REVISED DEVELOPMENT APPLICATION - MOD 2	3.12.25			
8	REVISED DEVELOPMENT APPLICATION - MOD 1	1.10.25			
7	REVISED DEVELOPMENT APPLICATION - MOD 1	3.9.25			
6	REVISED DEVELOPMENT APPLICATION	25.8.22			
5	DEVELOPMENT APPLICATION	19.8.22			
4	PRELIMINARY DEVELOPMENT APPLICATION	18.8.22			
3	PRELIMINARY DEVELOPMENT APPLICATION	12.8.22			
2	CLIENT REVIEW	6.7.22			

© Copyright MPC Consulting Engineers as date of issue

THIS DRAWING IS NOT TO BE USED FOR CONSTRUCTION UNLESS ENDORSED BELOW

COPYRIGHT

The concepts and information contained in this document are the copyright of MPC Consulting Engineers. Use or copying of the document in whole or in part without the written permission of MPC Consulting Engineers constitutes an infringement of copyright.

Level 1,
16 Telford Street,
NEWCASTLE EAST, NSW 2300
PO BOX 871
NEWCASTLE, NSW 2300
Tel: (02) 4927 5566
Email: admin@mpceng.com.au
Web: www.mpceng.com.au
A.C.N. 670 257 315

CLIENT
UNITING

TITLE
**SOIL AND WATER MANAGEMENT PLAN
STAGE 1**

PROJECT
**PROPOSED UNITING DEVELOPMENT AT;
LOT 223, DP 551260,
No.27 TIRAL STREET,
CHARLESTOWN**

DO NOT SCALE DRAWING

DRAWN	ENGINEER	No in SET	SHEET
J.D.L.	B.C.	-	A1
SCALES	JOB No	DRAWING No	ISSUE
1:500	200243	00101	9

FULL SIZE ON ORIGINAL 0 1 2 3 4 5 6 7 8 9 10 11 12 13 14 15 cm

SOIL AND WATER MANAGEMENT PLAN STAGE 2

BUILDING B WORKS SHEET 1

SCALE 1:500

SEDIMENTATION, EROSION CONTROL AND STORMWATER MANAGEMENT NOTES

1. SELECTIVE CLEARING OF VEGETATION TO BE RESTRICTED TO NOMINATED AREAS WITH CLEARED VEGETATION WIND ROWED ON THE CONTOUR.
2. ALL EROSION AND SEDIMENT CONTROL MEASURES TO BE INSTALLED PRIOR TO SITE DISTURBANCE.
3. TOPSOIL FROM ALL AREAS THAT WILL BE DISTURBED TO BE STRIPPED AND STOCKPILED AT THE NOMINATED SITE.
4. NO MORE THAN 150m OF TRENCH TO BE OPEN AT ANY ONE TIME.
5. CUT AND FILL BATTER GRADIENTS OF 1:2 (MAXIMUM).
6. A STRIP OF TURF 450mm WIDE IS TO BE PLACED IMMEDIATELY BEHIND THE KERB ON ALL NEW ROAD TO ACT AS A FILTER TRAP. REFER TO DETAIL SD6-13.
7. ALL SEDIMENT CONTROL STRUCTURES TO BE INSPECTED BY SITE SUPERVISOR AFTER EACH RAINFALL EVENT FOR STRUCTURAL DAMAGE AND ALL TRAPPED SEDIMENT TO BE REMOVED TO A NOMINATED STOCKPILE SITE.
8. THE PROJECT MANAGER TO INFORM ALL CONTRACTORS AND SUB-CONTRACTORS OF THEIR OBLIGATIONS UNDER THE STORMWATER MANAGEMENT PLAN.
9. NO DISTURBED AREA IS TO REMAIN DENUDED LONGER THAN 14 DAYS, UNLESS MANAGED BY THE CONTRACTOR TO ENSURE NO RUNOFF OCCURS.
10. ALL FILLS ARE TO BE LEFT WITH A LIP AT THE TOP OF THE SLOPE AT THE END OF EACH DAY'S OPERATION.
11. THE CONTRACTOR MUST ENSURE THE SUITABILITY AND INTEGRITY OF ALL WORKS AT THE END OF EACH DAY'S WORK AND CONSIDER HOLD OR INSPECTION POINTS AS STAGES OF WORKS PROGRESS.
12. ORANGE BARRIER TAPE TO BE AFFIXED TO TOP OF SEDIMENT CONTROL BARRIER TO IDENTIFY WORK AREA.
13. ALL SEDIMENTATION & EROSION CONTROL AND STORMWATER MANAGEMENT MEASURES ARE TO STRICTLY COMPLY WITH THE GUIDELINES DETAILED IN THE DEPARTMENT OF HOUSING PUBLICATION, "MANAGING URBAN STORMWATER - SOILS AND CONSTRUCTION", 4TH EDITION.
14. WATER TRUCKS TO BE USED AS REQUIRED TO PREVENT WIND EROSION.
15. SUBGRADE MATERIAL TO BE CONSTRUCTED IMMEDIATELY FOLLOWING FILL.

LEGEND

- DENOTES CATCHMENT ZONES
- DENOTES SURFACE FLOW DIRECTION
- DENOTES ALLOWABLE AREA FOR TEMPORARY STOCKPILING OF CUT SOIL MATERIAL, REFER TO DETAIL SD4-1
- DENOTES ROCK CHECK DAM, REFER TO DETAIL SD5-4
- DENOTES EARTH BANK (LOW FLOW), REFER TO DETAIL SD5-5
- DENOTES EARTHBANK (HIGH FLOW), REFER TO DETAIL SD5-6
- DENOTES SEDIMENT FENCE, REFER TO DETAIL SD6-8
- DENOTES MESH AND GRAVEL INLET FILTER, REFER TO DETAIL SD6-11
- DENOTES GEOTEXTILE INLET FILTER, REFER TO DETAIL SD6-12
- DENOTES STABILISED SITE ACCESS, REFER TO DETAIL SD6-14
- DENOTES LEVEL SPREADER

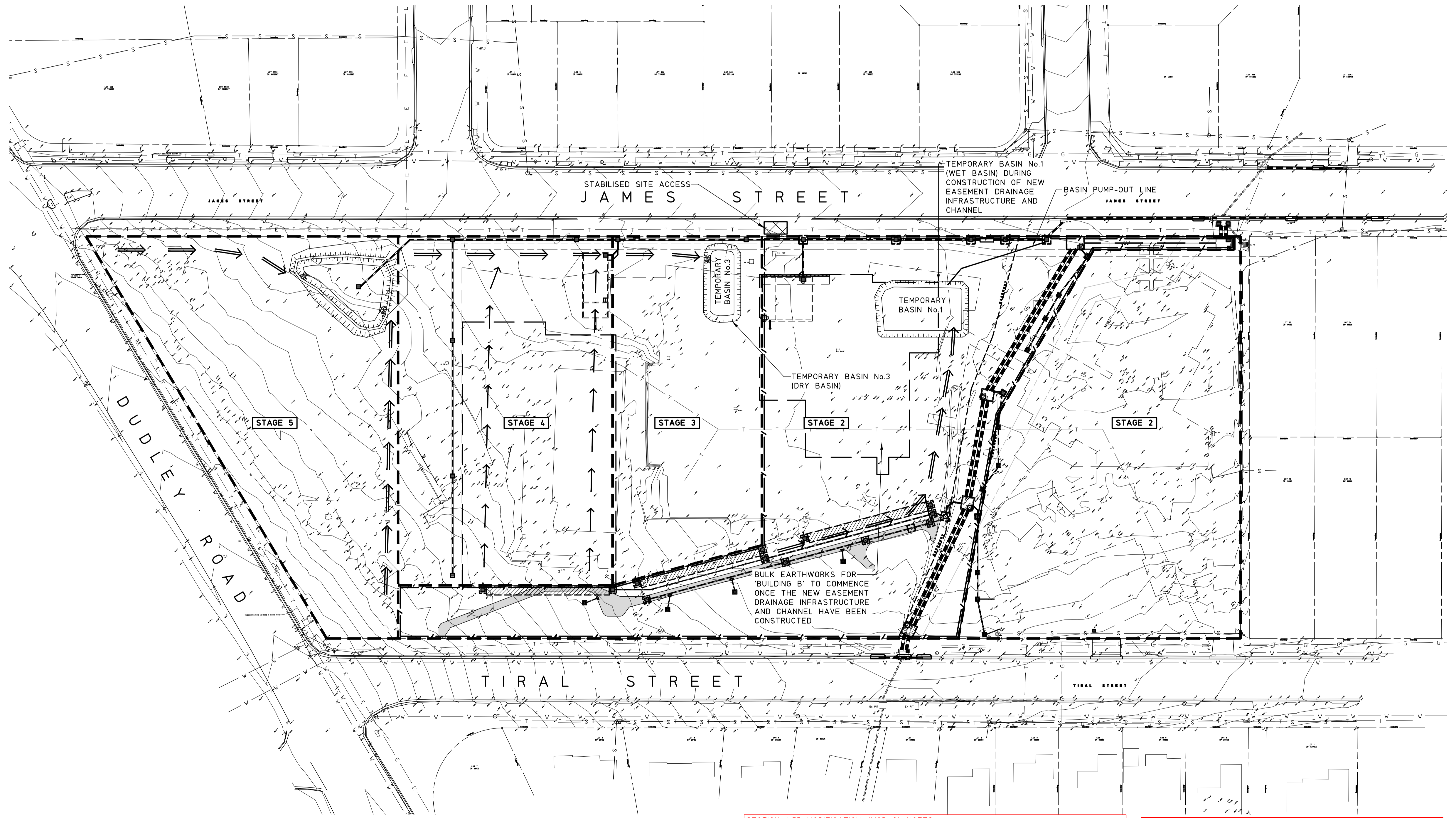

SECTION 4.55 MODIFICATION "MOD 2" NOTES
 CHANGES TO THE CIVIL DRAWINGS FOR "MOD 2" GENERALLY COMPRISE THE FOLLOWING:
 • COORDINATION WITH AMENDED GENERAL ARCHITECTURAL ARRANGEMENT

DRAWING TO BE PRINTED IN COLOUR

NOT FOR CONSTRUCTION

ISSUE	REASON FOR ISSUE	DATE	DATE OF RELEASE	RESPONSIBLE PRINCIPAL SIGNATURE	ISSUE
7	REVISED DEVELOPMENT APPLICATION - MOD 2	3.12.25			
6	REVISED DEVELOPMENT APPLICATION - MOD 1	1.10.25			
5	REVISED DEVELOPMENT APPLICATION - MOD 1	3.9.25			
4	REVISED DEVELOPMENT APPLICATION	25.8.22			
3	DEVELOPMENT APPLICATION	19.8.22			
2	PRELIMINARY DEVELOPMENT APPLICATION	12.8.22			
1	COORDINATION	1.7.22			
0	80% DA - CLIENT REVIEW	19.11.21			

© Copyright MPC Consulting Engineers as date of issue

THIS DRAWING IS NOT TO BE USED FOR CONSTRUCTION UNLESS ENDORSED BELOW

COPYRIGHT

The concepts and information contained in this document are the copyright of MPC Consulting Engineers. Use or copying of the document in whole or in part without the written permission of MPC Consulting Engineers constitutes an infringement of copyright.

Level 1,
 16 Telford Street,
 NEWCASTLE EAST, NSW 2300
 PO BOX 871
 NEWCASTLE, NSW 2300
 Tel: (02) 4927 5566
 Email: admin@mpceng.com.au
 Web: www.mpceng.com.au
 A.C.N. 670 257 315

CLIENT
UNITING

TITLE
**SOIL AND WATER MANAGEMENT PLAN
 STAGE 2 BUILDING B WORKS SHEET 1**

PROJECT
**PROPOSED UNITING DEVELOPMENT AT;
 LOT 223, DP 551260,
 No.27 TIRAL STREET,
 CHARLESTOWN**

DO NOT SCALE DRAWING

DRAWN	ENGINEER	No in SET	SHEET
J.D.L.	B.C.	-	A1
SCALES	JOB No	DRAWING No	ISSUE
1:500	200243	00102	7

FULL SIZE ON ORIGINAL 0 1 2 3 4 5 6 7 8 9 10 11 12 13 14 15 cm

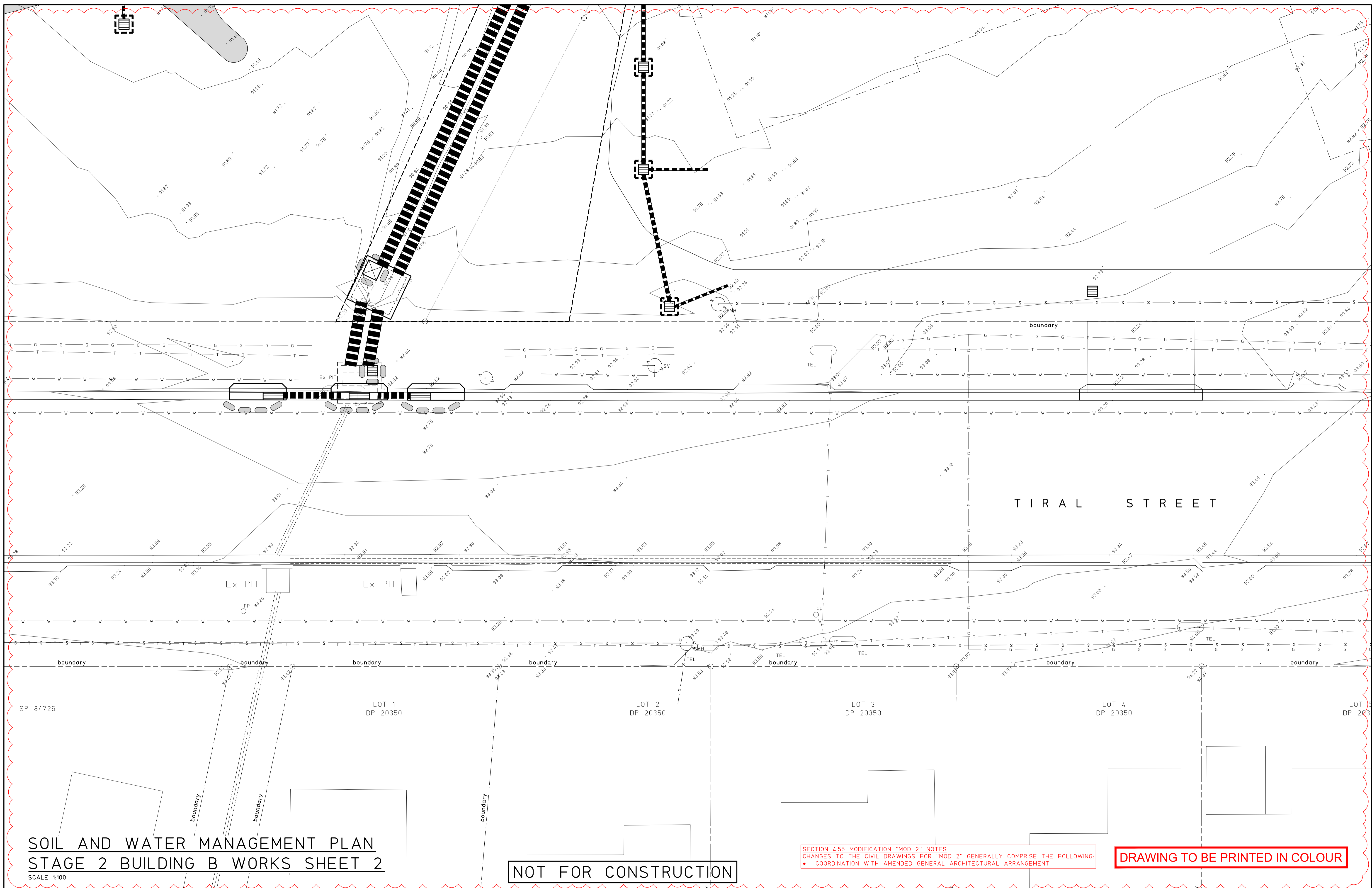

**SOIL AND WATER MANAGEMENT PLAN
STAGE 2 BUILDING B WORKS SHEET 2**

SCALE 1:100

NOT FOR CONSTRUCTION

SECTION 4.55 MODIFICATION "MOD 2" NOTES
CHANGES TO THE CIVIL DRAWINGS FOR "MOD 2" GENERALLY COMPRISE THE FOLLOWING:
• COORDINATION WITH AMENDED GENERAL ARCHITECTURAL ARRANGEMENT

DRAWING TO BE PRINTED IN COLOUR

6	REVISED DEVELOPMENT APPLICATION - MOD 2	3.12.25
5	REVISED DEVELOPMENT APPLICATION - MOD 1	3.9.25
4	REVISED DEVELOPMENT APPLICATION	25.8.22
3	DEVELOPMENT APPLICATION	19.8.22
2	PRELIMINARY DEVELOPMENT APPLICATION	12.8.22
1	COORDINATION	1.7.22
0	80% DA - CLIENT REVIEW	19.11.21

REASON FOR ISSUE	DATE	DATE OF RELEASE	RESPONSIBLE PRINCIPAL SIGNATURE	ISSUE
------------------	------	-----------------	---------------------------------	-------

© Copyright MPC Consulting Engineers as date of issue
**THIS DRAWING IS NOT TO BE
USED FOR CONSTRUCTION UNLESS ENDORSED BELOW**

COPYRIGHT
The concepts and information contained in this document are the copyright of MPC Consulting Engineers. Use or copying of the document in whole or in part without the written permission of MPC Consulting Engineers constitutes an infringement of copyright.



Level 1,
16 Telford Street,
NEWCASTLE EAST, NSW 2300
PO BOX 871
NEWCASTLE, NSW 2300
Tel: (02) 4927 5566
Email: admin@mpceng.com.au
Web: www.mpceng.com.au
A.C.N. 670 257 315

CLIENT
UNITING
TITLE
**SOIL AND WATER MANAGEMENT PLAN
STAGE 2 BUILDING B WORKS SHEET 2**

PROJECT
**PROPOSED UNITING DEVELOPMENT AT;
LOT 223, DP 551260,
No.27 TIRAL STREET,
CHARLESTOWN**

DO NOT SCALE DRAWING			
DRAWN J.D.L.	ENGINEER B.C.	No in SET -	SHEET A1
SCALES 1:100	JOB No 200243	DRAWING No 00103	ISSUE 6

FULL SIZE ON ORIGINAL 0 1 2 3 4 5 6 7 8 9 10 11 12 13 14 15 cm

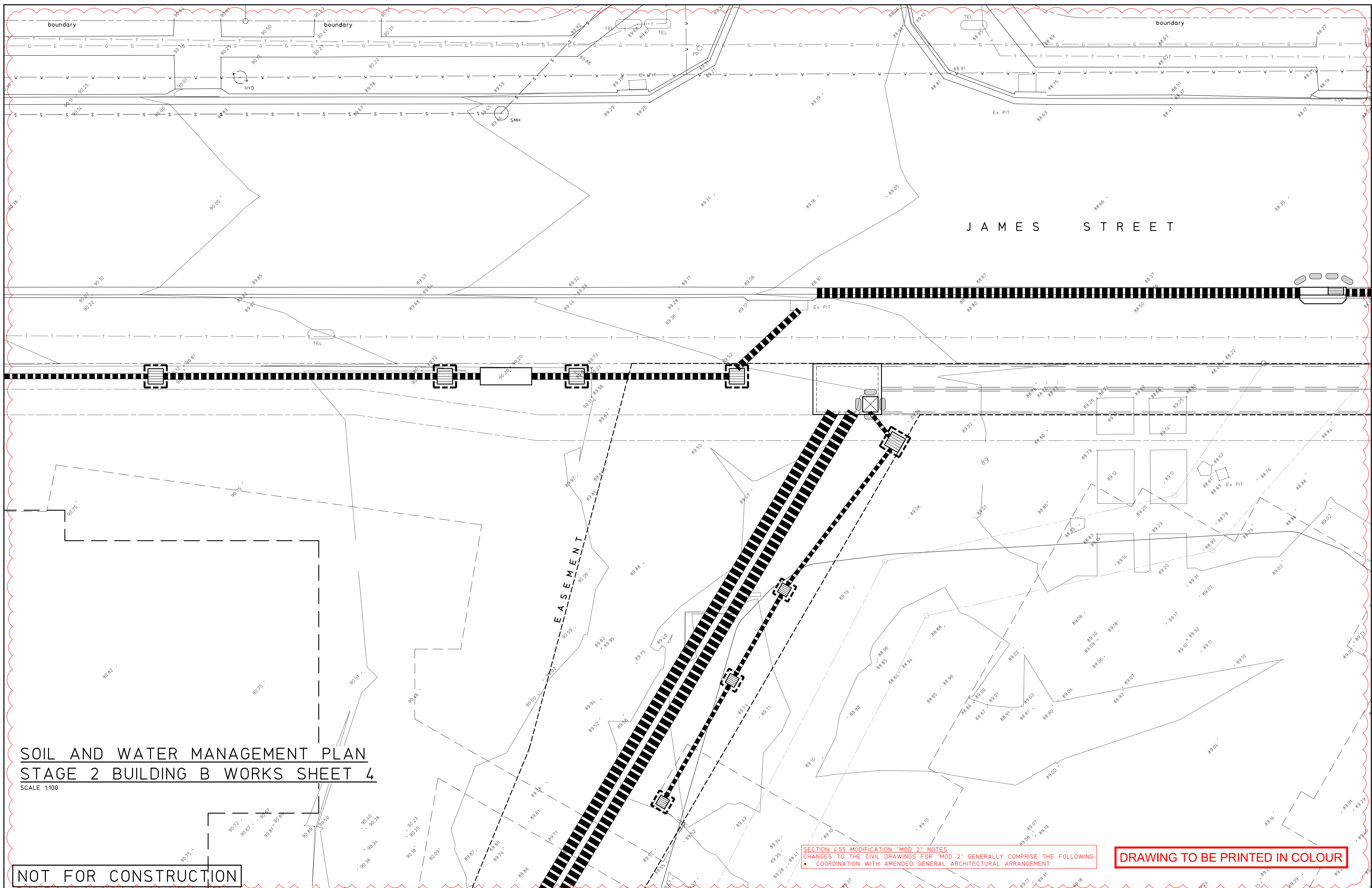

**SOIL AND WATER MANAGEMENT PLAN
STAGE 2 BUILDING B WORKS SHEET 4**

SCALE 1:100

NOT FOR CONSTRUCTION

SECTION 4.55 MODIFICATION "MOD 2" NOTES
CHANGES TO THE CIVIL DRAWINGS FOR "MOD 2" GENERALLY COMPRISE THE FOLLOWING:
• COORDINATION WITH AMENDED GENERAL ARCHITECTURAL ARRANGEMENT

DRAWING TO BE PRINTED IN COLOUR

6	REVISED DEVELOPMENT APPLICATION - MOD 2	3.12.25
5	REVISED DEVELOPMENT APPLICATION - MOD 1	3.9.25
4	REVISED DEVELOPMENT APPLICATION	25.8.22
3	DEVELOPMENT APPLICATION	19.8.22
2	PRELIMINARY DEVELOPMENT APPLICATION	12.8.22
1	COORDINATION	1.7.22
0	80% DA - CLIENT REVIEW	19.11.21
ISSUE	REASON FOR ISSUE	DATE

© Copyright MPC Consulting Engineers as date of issue	
THIS DRAWING IS NOT TO BE USED FOR CONSTRUCTION UNLESS ENDORSED BELOW	
RESPONSIBLE PRINCIPAL SIGNATURE	ISSUE

copyright
The concepts and information contained in this document are the copyright of MPC Consulting Engineers. Use or copying of the document in whole or in part without the written permission of MPC Consulting Engineers constitutes an infringement of copyright.

Level 1,
16 Telford Street,
NEWCASTLE EAST, NSW 2300
PO BOX 871
NEWCASTLE, NSW 2300
Tel: (02) 4927 5566
Email: admin@mpceng.com.au
Web: www.mpceng.com.au
A.C.N. 670 257 315

CLIENT UNITING
TITLE SOIL AND WATER MANAGEMENT PLAN STAGE 2 BUILDING B WORKS SHEET 4

PROJECT PROPOSED UNITING DEVELOPMENT AT; LOT 223, DP 551260, No.27 TIRAL STREET, CHARLESTOWN
--

DO NOT SCALE DRAWING			
DRAWN J.D.L.	ENGINEER B.C.	No in SET -	SHEET A1
SCALES 1:100	JOB No 200243	DRAWING No 00105	ISSUE 6

SOIL AND WATER MANAGEMENT PLAN

RAC BUILDING WORKS STAGE 2D

SCALE 1:500

SEDIMENTATION, EROSION CONTROL AND STORMWATER MANAGEMENT NOTES

1. SELECTIVE CLEARING OF VEGETATION TO BE RESTRICTED TO NOMINATED AREAS WITH CLEARED VEGETATION WIND ROWED ON THE CONTOUR.
2. ALL EROSION AND SEDIMENT CONTROL MEASURES TO BE INSTALLED PRIOR TO SITE DISTURBANCE.
3. TOPSOIL FROM ALL AREAS THAT WILL BE DISTURBED TO BE STRIPPED AND STOCKPILED AT THE NOMINATED SITE.
4. NO MORE THAN 150m OF TRENCH TO BE OPEN AT ANY ONE TIME.
5. CUT AND FILL BATTER GRADIENTS OF 1:2 (MAXIMUM).
6. A STRIP OF TURF 450mm WIDE IS TO BE PLACED IMMEDIATELY BEHIND THE KERB ON ALL NEW ROAD TO ACT AS A FILTER TRAP. REFER TO DETAIL SD6-13.
7. ALL SEDIMENT CONTROL STRUCTURES TO BE INSPECTED BY SITE SUPERVISOR AFTER EACH RAINFALL EVENT FOR STRUCTURAL DAMAGE AND ALL TRAPPED SEDIMENT TO BE REMOVED TO A NOMINATED STOCKPILE SITE.
8. THE PROJECT MANAGER TO INFORM ALL CONTRACTORS AND SUB-CONTRACTORS OF THEIR OBLIGATIONS UNDER THE STORMWATER MANAGEMENT PLAN.
9. NO DISTURBED AREA IS TO REMAIN DENUDED LONGER THAN 14 DAYS, UNLESS MANAGED BY THE CONTRACTOR TO ENSURE NO RUNOFF OCCURS.
10. ALL FILLS ARE TO BE LEFT WITH A LIP AT THE TOP OF THE SLOPE AT THE END OF EACH DAY'S OPERATION.
11. THE CONTRACTOR MUST ENSURE THE SUITABILITY AND INTEGRITY OF ALL WORKS AT THE END OF EACH DAY'S WORK AND CONSIDER HOLD OR INSPECTION POINTS AS STAGES OF WORKS PROGRESS.
12. ORANGE BARRIER TAPE TO BE AFFIXED TO TOP OF SEDIMENT CONTROL BARRIER TO IDENTIFY WORK AREA.
13. ALL SEDIMENTATION & EROSION CONTROL AND STORMWATER MANAGEMENT MEASURES ARE TO STRICTLY COMPLY WITH THE GUIDELINES DETAILED IN THE DEPARTMENT OF HOUSING PUBLICATION, "MANAGING URBAN STORMWATER - SOILS AND CONSTRUCTION", 4TH EDITION.
14. WATER TRUCKS TO BE USED AS REQUIRED TO PREVENT WIND EROSION.
15. SUBGRADE MATERIAL TO BE CONSTRUCTED IMMEDIATELY FOLLOWING FILL.

LEGEND	
	DENOTES CATCHMENT ZONES
	DENOTES SURFACE FLOW DIRECTION
	DENOTES ALLOWABLE AREA FOR TEMPORARY STOCKPILING OF CUT SOIL MATERIAL, REFER TO DETAIL SD4-1
	DENOTES ROCK CHECK DAM, REFER TO DETAIL SD5-4
	DENOTES EARTH BANK (LOW FLOW), REFER TO DETAIL SD5-5
	DENOTES EARTHBANK (HIGH FLOW), REFER TO DETAIL SD5-6
	DENOTES SEDIMENT FENCE, REFER TO DETAIL SD6-8
	DENOTES MESH AND GRAVEL INLET FILTER, REFER TO DETAIL SD6-11
	DENOTES GEOTEXTILE INLET FILTER, REFER TO DETAIL SD6-12
	DENOTES STABILISED SITE ACCESS, REFER TO DETAIL SD6-14
	DENOTES LEVEL SPREADER



SECTION 4.55 MODIFICATION "MOD 2" NOTES
 CHANGES TO THE CIVIL DRAWINGS FOR "MOD 2" GENERALLY COMPRISE THE FOLLOWING:
 • COORDINATION WITH AMENDED GENERAL ARCHITECTURAL ARRANGEMENT

DRAWING TO BE PRINTED IN COLOUR

NOT FOR CONSTRUCTION

ISSUE	REASON FOR ISSUE	DATE	DATE OF RELEASE	RESPONSIBLE PRINCIPAL SIGNATURE	ISSUE
7	REVISED DEVELOPMENT APPLICATION - MOD 2	3.12.25			
6	REVISED DEVELOPMENT APPLICATION - MOD 1	1.10.25			
5	REVISED DEVELOPMENT APPLICATION - MOD 1	3.9.25			
4	REVISED DEVELOPMENT APPLICATION	25.8.22			
3	DEVELOPMENT APPLICATION	19.8.22			
2	PRELIMINARY DEVELOPMENT APPLICATION	12.8.22			
1	COORDINATION	1.7.22			
0	80% DA - CLIENT REVIEW	19.11.21			

© Copyright MPC Consulting Engineers as date of issue

THIS DRAWING IS NOT TO BE USED FOR CONSTRUCTION UNLESS ENDORSED BELOW

COPYRIGHT

The concepts and information contained in this document are the copyright of MPC Consulting Engineers. Use or copying of the document in whole or in part without the written permission of MPC Consulting Engineers constitutes an infringement of copyright.

Level 1,
16 Telford Street,
NEWCASTLE EAST, NSW 2300
PO BOX 871
NEWCASTLE, NSW 2300
Tel: (02) 4927 5566
Email: admin@mpceng.com.au
Web: www.mpceng.com.au
A.C.N. 670 257 315

CLIENT
UNITING

TITLE
**SOIL AND WATER MANAGEMENT PLAN
RAC BUILDING WORKS STAGE 2D**

PROJECT
**PROPOSED UNITING DEVELOPMENT AT;
LOT 223, DP 551260,
No.27 TIRAL STREET,
CHARLESTOWN**

DO NOT SCALE DRAWING			
DRAWN J.D.L.	ENGINEER B.C.	No in SET -	SHEET A1
SCALES 1:500	JOB No 200243	DRAWING No 00107	ISSUE 7

FULL SIZE ON ORIGINAL 0 1 2 3 4 5 6 7 8 9 10 11 12 13 14 15 cm

SOIL AND WATER MANAGEMENT PLAN

BUILDING C WORKS STAGE 3

SCALE 1:500

SEDIMENTATION, EROSION CONTROL AND STORMWATER MANAGEMENT NOTES

1. SELECTIVE CLEARING OF VEGETATION TO BE RESTRICTED TO NOMINATED AREAS WITH CLEARED VEGETATION WIND ROWED ON THE CONTOUR.
2. ALL EROSION AND SEDIMENT CONTROL MEASURES TO BE INSTALLED PRIOR TO SITE DISTURBANCE.
3. TOPSOIL FROM ALL AREAS THAT WILL BE DISTURBED TO BE STRIPPED AND STOCKPILED AT THE NOMINATED SITE.
4. NO MORE THAN 150m OF TRENCH TO BE OPEN AT ANY ONE TIME.
5. CUT AND FILL BATTER GRADIENTS OF 1:2 (MAXIMUM).
6. A STRIP OF TURF 450mm WIDE IS TO BE PLACED IMMEDIATELY BEHIND THE KERB ON ALL NEW ROAD TO ACT AS A FILTER TRAP. REFER TO DETAIL SD6-13.
7. ALL SEDIMENT CONTROL STRUCTURES TO BE INSPECTED BY SITE SUPERVISOR AFTER EACH RAINFALL EVENT FOR STRUCTURAL DAMAGE AND ALL TRAPPED SEDIMENT TO BE REMOVED TO A NOMINATED STOCKPILE SITE.
8. THE PROJECT MANAGER TO INFORM ALL CONTRACTORS AND SUB-CONTRACTORS OF THEIR OBLIGATIONS UNDER THE STORMWATER MANAGEMENT PLAN.
9. NO DISTURBED AREA IS TO REMAIN DENUDED LONGER THAN 14 DAYS, UNLESS MANAGED BY THE CONTRACTOR TO ENSURE NO RUNOFF OCCURS.
10. ALL FILLS ARE TO BE LEFT WITH A LIP AT THE TOP OF THE SLOPE AT THE END OF EACH DAY'S OPERATION.
11. THE CONTRACTOR MUST ENSURE THE SUITABILITY AND INTEGRITY OF ALL WORKS AT THE END OF EACH DAY'S WORK AND CONSIDER HOLD OR INSPECTION POINTS AS STAGES OF WORKS PROGRESS.
12. ORANGE BARRIER TAPE TO BE AFFIXED TO TOP OF SEDIMENT CONTROL BARRIER TO IDENTIFY WORK AREA.
13. ALL SEDIMENTATION & EROSION CONTROL AND STORMWATER MANAGEMENT MEASURES ARE TO STRICTLY COMPLY WITH THE GUIDELINES DETAILED IN THE DEPARTMENT OF HOUSING PUBLICATION, "MANAGING URBAN STORMWATER - SOILS AND CONSTRUCTION", 4TH EDITION.
14. WATER TRUCKS TO BE USED AS REQUIRED TO PREVENT WIND EROSION.
15. SUBGRADE MATERIAL TO BE CONSTRUCTED IMMEDIATELY FOLLOWING FILL.

LEGEND

- DENOTES CATCHMENT ZONES
- DENOTES SURFACE FLOW DIRECTION
- DENOTES ALLOWABLE AREA FOR TEMPORARY STOCKPILING OF CUT SOIL MATERIAL, REFER TO DETAIL SD4-1
- DENOTES ROCK CHECK DAM, REFER TO DETAIL SD5-4
- DENOTES EARTH BANK (LOW FLOW), REFER TO DETAIL SD5-5
- DENOTES EARTHBANK (HIGH FLOW), REFER TO DETAIL SD5-6
- DENOTES SEDIMENT FENCE, REFER TO DETAIL SD6-8
- DENOTES MESH AND GRAVEL INLET FILTER, REFER TO DETAIL SD6-11
- DENOTES GEOTEXTILE INLET FILTER, REFER TO DETAIL SD6-12
- DENOTES STABILISED SITE ACCESS, REFER TO DETAIL SD6-14
- DENOTES LEVEL SPREADER

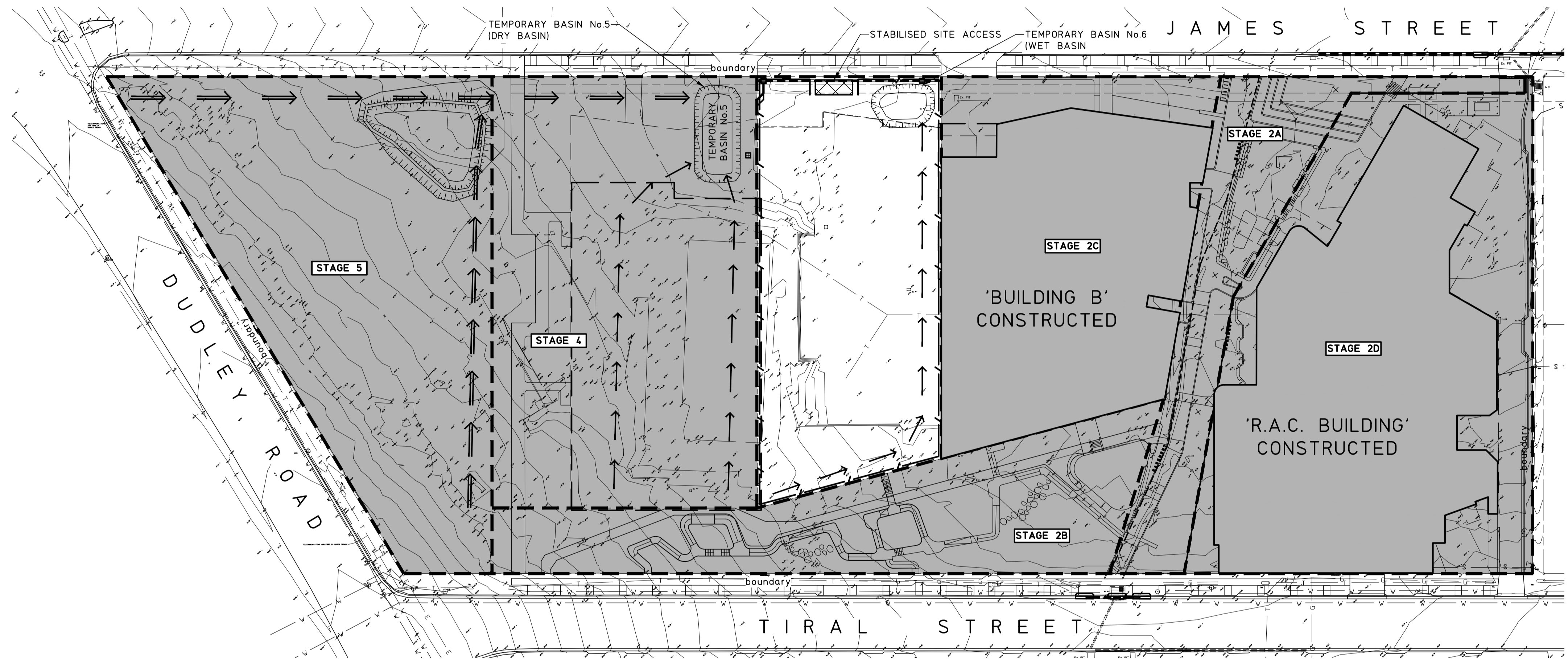

SECTION 4.55. MODIFICATION "MOD 2" NOTES
 CHANGES TO THE CIVIL DRAWINGS FOR "MOD 2" GENERALLY COMPRISE THE FOLLOWING:
 • COORDINATION WITH AMENDED GENERAL ARCHITECTURAL ARRANGEMENT

DRAWING TO BE PRINTED IN COLOUR

NOT FOR CONSTRUCTION

6 REVISED DEVELOPMENT APPLICATION - MOD 2 3.12.25 5 REVISED DEVELOPMENT APPLICATION - MOD 1 3.9.25 4 REVISED DEVELOPMENT APPLICATION 25.8.22 3 DEVELOPMENT APPLICATION 19.8.22 2 PRELIMINARY DEVELOPMENT APPLICATION 12.8.22 1 COORDINATION 1.7.22 0 80% DA - CLIENT REVIEW 19.11.21		© Copyright MPC Consulting Engineers as date of issue THIS DRAWING IS NOT TO BE USED FOR CONSTRUCTION UNLESS ENDORSED BELOW		COPYRIGHT The concepts and information contained in this document are the copyright of MPC Consulting Engineers. Use or copying of the document in whole or in part without the written permission of MPC Consulting Engineers constitutes an infringement of copyright.		CLIENT UNITING TITLE SOIL AND WATER MANAGEMENT PLAN BUILDING C WORKS STAGE 3		PROJECT PROPOSED UNITING DEVELOPMENT AT; LOT 223, DP 551260, No.27 TIRAL STREET, CHARLESTOWN		DO NOT SCALE DRAWING					
DRAWN J.D.L.		ENGINEER B.C.		No in SET -		SHEET A1		SCALES 1:500		JOB No 200243		DRAWING No 00108		ISSUE 6	
ISSUE REASON FOR ISSUE		DATE		DATE OF RELEASE		RESPONSIBLE PRINCIPAL SIGNATURE		ISSUE		FULL SIZE ON ORIGINAL 0 1 2 3 4 5 6 7 8 9 10 11 12 13 14 15 cm					

SOIL AND WATER MANAGEMENT PLAN

BUILDING D WORKS STAGE 4

SCALE 1:500

SEDIMENTATION, EROSION CONTROL AND STORMWATER MANAGEMENT NOTES

1. SELECTIVE CLEARING OF VEGETATION TO BE RESTRICTED TO NOMINATED AREAS WITH CLEARED VEGETATION WIND ROWED ON THE CONTOUR.
2. ALL EROSION AND SEDIMENT CONTROL MEASURES TO BE INSTALLED PRIOR TO SITE DISTURBANCE.
3. TOPSOIL FROM ALL AREAS THAT WILL BE DISTURBED TO BE STRIPPED AND STOCKPILED AT THE NOMINATED SITE.
4. NO MORE THAN 150m OF TRENCH TO BE OPEN AT ANY ONE TIME.
5. CUT AND FILL BATTER GRADIENTS OF 1:2 (MAXIMUM).
6. A STRIP OF TURF 450mm WIDE IS TO BE PLACED IMMEDIATELY BEHIND THE KERB ON ALL NEW ROAD TO ACT AS A FILTER TRAP. REFER TO DETAIL SD6-13.
7. ALL SEDIMENT CONTROL STRUCTURES TO BE INSPECTED BY SITE SUPERVISOR AFTER EACH RAINFALL EVENT FOR STRUCTURAL DAMAGE AND ALL TRAPPED SEDIMENT TO BE REMOVED TO A NOMINATED STOCKPILE SITE.
8. THE PROJECT MANAGER TO INFORM ALL CONTRACTORS AND SUB-CONTRACTORS OF THEIR OBLIGATIONS UNDER THE STORMWATER MANAGEMENT PLAN.
9. NO DISTURBED AREA IS TO REMAIN DENUDED LONGER THAN 14 DAYS, UNLESS MANAGED BY THE CONTRACTOR TO ENSURE NO RUNOFF OCCURS.
10. ALL FILLS ARE TO BE LEFT WITH A LIP AT THE TOP OF THE SLOPE AT THE END OF EACH DAY'S OPERATION.
11. THE CONTRACTOR MUST ENSURE THE SUITABILITY AND INTEGRITY OF ALL WORKS AT THE END OF EACH DAY'S WORK AND CONSIDER HOLD OR INSPECTION POINTS AS STAGES OF WORKS PROGRESS.
12. ORANGE BARRIER TAPE TO BE AFFIXED TO TOP OF SEDIMENT CONTROL BARRIER TO IDENTIFY WORK AREA.
13. ALL SEDIMENTATION & EROSION CONTROL AND STORMWATER MANAGEMENT MEASURES ARE TO STRICTLY COMPLY WITH THE GUIDELINES DETAILED IN THE DEPARTMENT OF HOUSING PUBLICATION, "MANAGING URBAN STORMWATER - SOILS AND CONSTRUCTION", 4TH EDITION.
14. WATER TRUCKS TO BE USED AS REQUIRED TO PREVENT WIND EROSION.
15. SUBGRADE MATERIAL TO BE CONSTRUCTED IMMEDIATELY FOLLOWING FILL.

LEGEND

- DENOTES CATCHMENT ZONES
- DENOTES SURFACE FLOW DIRECTION
- DENOTES ALLOWABLE AREA FOR TEMPORARY STOCKPILING OF CUT SOIL MATERIAL, REFER TO DETAIL SD4-1
- DENOTES ROCK CHECK DAM, REFER TO DETAIL SD5-4
- DENOTES TEMPORARY WATERWAY CROSSING, REFER TO DETAIL SD5-1
- DENOTES EARTH BANK (LOW FLOW), REFER TO DETAIL SD5-5
- DENOTES EARTH BANK (HIGH FLOW), REFER TO DETAIL SD5-6
- DENOTES SEDIMENT FENCE, REFER TO DETAIL SD6-8
- DENOTES MESH AND GRAVEL INLET FILTER, REFER TO DETAIL SD6-11
- DENOTES GEOTEXTILE INLET FILTER, REFER TO DETAIL SD6-12
- DENOTES STABILISED SITE ACCESS, REFER TO DETAIL SD6-14
- DENOTES LEVEL SPREADER

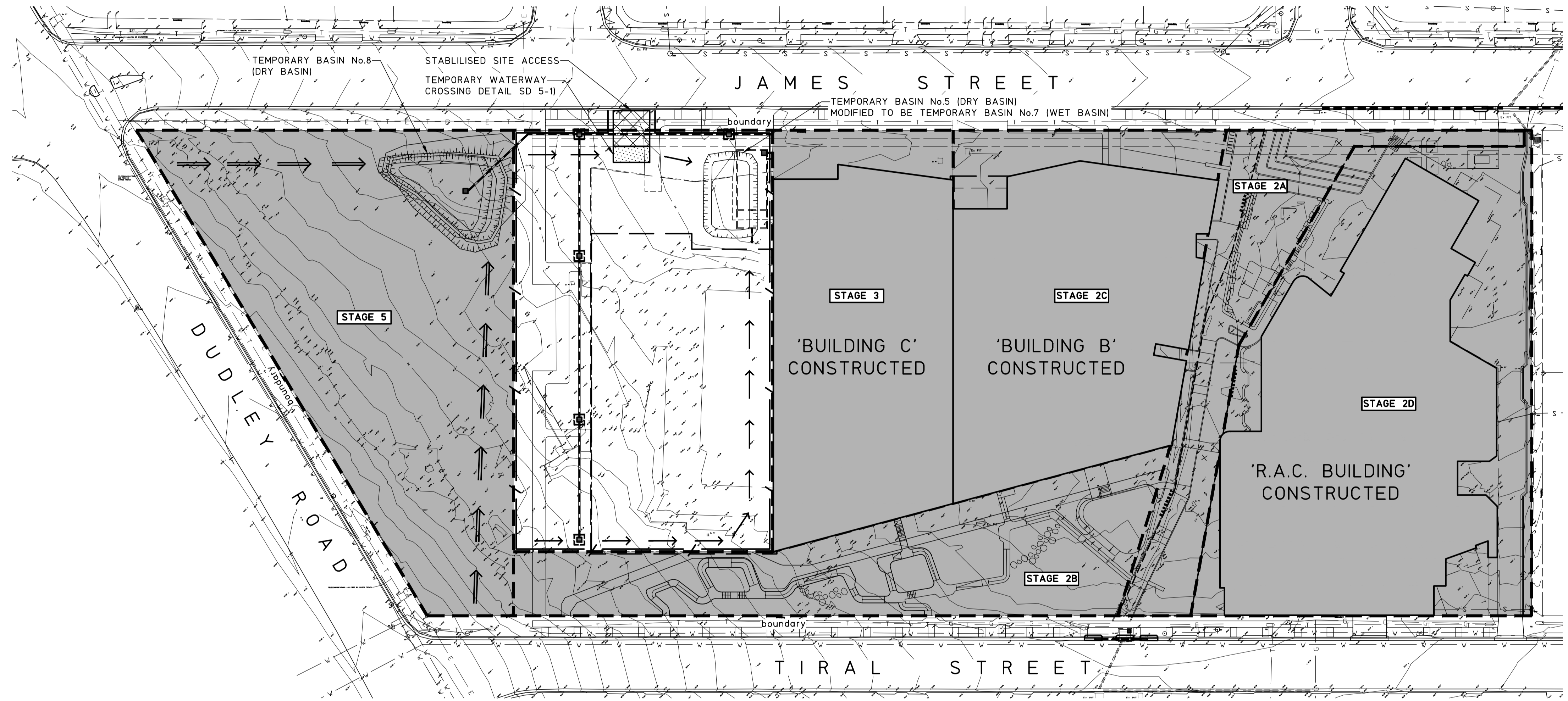

SECTION 4.55 MODIFICATION "MOD 2" NOTES
 CHANGES TO THE CIVIL DRAWINGS FOR "MOD 2" GENERALLY COMPRISE THE FOLLOWING:
 • COORDINATION WITH AMENDED GENERAL ARCHITECTURAL ARRANGEMENT

DRAWING TO BE PRINTED IN COLOUR

NOT FOR CONSTRUCTION

6	REVISED DEVELOPMENT APPLICATION - MOD 2	3.12.25	© Copyright MPC Consulting Engineers as date of issue		
5	REVISED DEVELOPMENT APPLICATION - MOD 1	3.9.25	<p style="text-align: center;">THIS DRAWING IS NOT TO BE USED FOR CONSTRUCTION UNLESS ENDORSED BELOW</p> <p>COPYRIGHT The concepts and information contained in this document are the copyright of MPC Consulting Engineers. Use or copying of the document in whole or in part without the written permission of MPC Consulting Engineers constitutes an infringement of copyright.</p> Level 1, 16 Telford Street, NEWCASTLE EAST, NSW 2300 PO BOX 871 NEWCASTLE, NSW 2300 Tel: (02) 4927 5566 Email: admin@mpceng.com.au Web: www.mpceng.com.au A.C.N. 670 257 315		
4	REVISED DEVELOPMENT APPLICATION	25.8.22			
3	DEVELOPMENT APPLICATION	19.8.22			
2	PRELIMINARY DEVELOPMENT APPLICATION	12.8.22			
1	COORDINATION	1.7.22			
0	80% DA - CLIENT REVIEW	19.11.21			
ISSUE	REASON FOR ISSUE	DATE	DATE OF RELEASE	RESPONSIBLE PRINCIPAL SIGNATURE	ISSUE

CLIENT
UNITING

TITLE
**SOIL AND WATER MANAGEMENT PLAN
 BUILDING D WORKS STAGE 4**

PROJECT
**PROPOSED UNITING DEVELOPMENT AT;
 LOT 223, DP 551260,
 No.27 TIRAL STREET,
 CHARLESTOWN**

DO NOT SCALE DRAWING

DRAWN J.D.L.	ENGINEER B.C.	No in SET -	SHEET A1
SCALES 1:500	JOB No 200243	DRAWING No 00109	ISSUE 6

FULL SIZE ON ORIGINAL 0 1 2 3 4 5 6 7 8 9 10 11 12 13 14 15 cm

SOIL AND WATER MANAGEMENT PLAN STAGE 5

SCALE 1:500

SEDIMENTATION, EROSION CONTROL AND STORMWATER MANAGEMENT NOTES

1. SELECTIVE CLEARING OF VEGETATION TO BE RESTRICTED TO NOMINATED AREAS WITH CLEARED VEGETATION WIND ROWED ON THE CONTOUR.
2. ALL EROSION AND SEDIMENT CONTROL MEASURES TO BE INSTALLED PRIOR TO SITE DISTURBANCE.
3. TOPSOIL FROM ALL AREAS THAT WILL BE DISTURBED TO BE STRIPPED AND STOCKPILED AT THE NOMINATED SITE.
4. NO MORE THAN 150m OF TRENCH TO BE OPEN AT ANY ONE TIME.
5. CUT AND FILL BATTER GRADIENTS OF 1:2 (MAXIMUM).
6. A STRIP OF TURF 450mm WIDE IS TO BE PLACED IMMEDIATELY BEHIND THE KERB ON ALL NEW ROAD TO ACT AS A FILTER TRAP. REFER TO DETAIL SD6-13.
7. ALL SEDIMENT CONTROL STRUCTURES TO BE INSPECTED BY SITE SUPERVISOR AFTER EACH RAINFALL EVENT FOR STRUCTURAL DAMAGE AND ALL TRAPPED SEDIMENT TO BE REMOVED TO A NOMINATED STOCKPILE SITE.
8. THE PROJECT MANAGER TO INFORM ALL CONTRACTORS AND SUB-CONTRACTORS OF THEIR OBLIGATIONS UNDER THE STORMWATER MANAGEMENT PLAN.
9. NO DISTURBED AREA IS TO REMAIN DENUDED LONGER THAN 14 DAYS, UNLESS MANAGED BY THE CONTRACTOR TO ENSURE NO RUNOFF OCCURS.
10. ALL FILLS ARE TO BE LEFT WITH A LIP AT THE TOP OF THE SLOPE AT THE END OF EACH DAY'S OPERATION.
11. THE CONTRACTOR MUST ENSURE THE SUITABILITY AND INTEGRITY OF ALL WORKS AT THE END OF EACH DAY'S WORK AND CONSIDER HOLD OR INSPECTION POINTS AS STAGES OF WORKS PROGRESS.
12. ORANGE BARRIER TAPE TO BE AFFIXED TO TOP OF SEDIMENT CONTROL BARRIER TO IDENTIFY WORK AREA.
13. ALL SEDIMENTATION & EROSION CONTROL AND STORMWATER MANAGEMENT MEASURES ARE TO STRICTLY COMPLY WITH THE GUIDELINES DETAILED IN THE DEPARTMENT OF HOUSING PUBLICATION, "MANAGING URBAN STORMWATER - SOILS AND CONSTRUCTION", 4TH EDITION.
14. WATER TRUCKS TO BE USED AS REQUIRED TO PREVENT WIND EROSION.
15. SUBGRADE MATERIAL TO BE CONSTRUCTED IMMEDIATELY FOLLOWING FILL.

LEGEND	
	DENOTES CATCHMENT ZONES
	DENOTES SURFACE FLOW DIRECTION
	DENOTES ALLOWABLE AREA FOR TEMPORARY STOCKPILING OF CUT SOIL MATERIAL, REFER TO DETAIL SD4-1
	DENOTES ROCK CHECK DAM, REFER TO DETAIL SD5-4
	DENOTES EARTH BANK (LOW FLOW), REFER TO DETAIL SD5-5
	DENOTES EARTHBANK (HIGH FLOW), REFER TO DETAIL SD5-6
	DENOTES SEDIMENT FENCE, REFER TO DETAIL SD6-8
	DENOTES MESH AND GRAVEL INLET FILTER, REFER TO DETAIL SD6-11
	DENOTES GEOTEXTILE INLET FILTER, REFER TO DETAIL SD6-12
	DENOTES STABILISED SITE ACCESS, REFER TO DETAIL SD6-14
	DENOTES LEVEL SPREADER

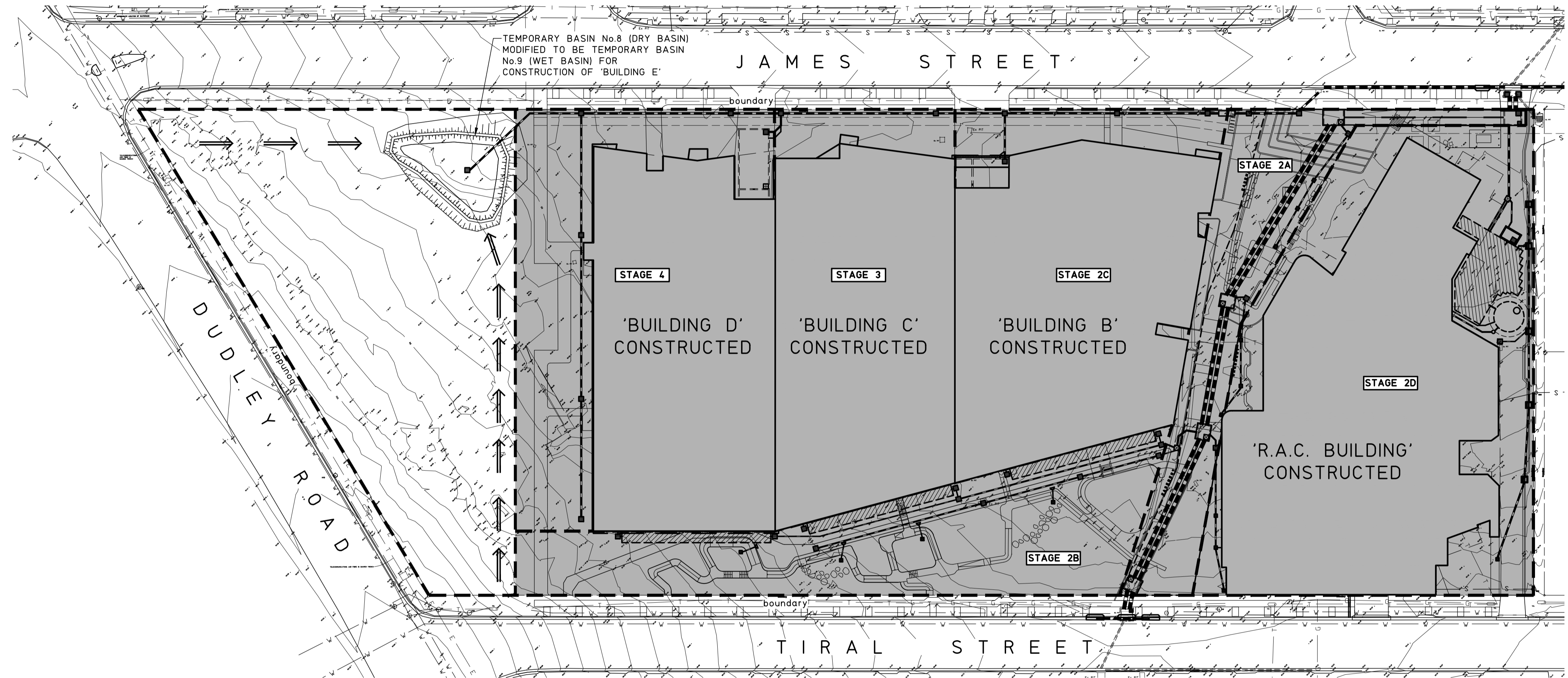

SECTION 4.55 MODIFICATION "MOD 2" NOTES
 CHANGES TO THE CIVIL DRAWINGS FOR "MOD 2" GENERALLY COMPRISE THE FOLLOWING:
 • COORDINATION WITH AMENDED GENERAL ARCHITECTURAL ARRANGEMENT

DRAWING TO BE PRINTED IN COLOUR

NOT FOR CONSTRUCTION

7	REVISED DEVELOPMENT APPLICATION - MOD 2	3.12.25	© Copyright MPC Consulting Engineers as date of issue		
6	REVISED DEVELOPMENT APPLICATION - MOD 1	1.10.25	THIS DRAWING IS NOT TO BE USED FOR CONSTRUCTION UNLESS ENDORSED BELOW		
5	REVISED DEVELOPMENT APPLICATION - MOD 1	3.9.25			
4	REVISED DEVELOPMENT APPLICATION	25.8.22			
3	DEVELOPMENT APPLICATION	19.8.22			
2	PRELIMINARY DEVELOPMENT APPLICATION	12.8.22			
1	COORDINATION	1.7.22	COPYRIGHT The concepts and information contained in this document are the copyright of MPC Consulting Engineers Use or copying of the document in whole or in part without the written permission of MPC Consulting Engineers constitutes an infringement of copyright.		
0	80% DA - CLIENT REVIEW	19.11.21			
ISSUE	REASON FOR ISSUE	DATE	DATE OF RELEASE	RESPONSIBLE PRINCIPAL SIGNATURE	ISSUE

mpc
 consulting engineers
 civil+structural

Level 1,
 16 Telford Street,
 NEWCASTLE EAST, NSW 2300
 PO BOX 871
 NEWCASTLE, NSW 2300
 Tel: (02) 4927 5566
 Email: admin@mpceng.com.au
 Web: www.mpceng.com.au
 A.C.N. 670 257 315

CLIENT
UNITING

TITLE
SOIL AND WATER MANAGEMENT PLAN STAGE 5

PROJECT
**PROPOSED UNITING DEVELOPMENT AT;
 LOT 223, DP 551260,
 No.27 TIRAL STREET,
 CHARLESTOWN**

DO NOT SCALE DRAWING			
DRAWN J.D.L.	ENGINEER B.C.	No in SET -	SHEET A1
SCALES 1:500	JOB No 200243	DRAWING No 00110	ISSUE 7

FULL SIZE ON ORIGINAL 0 1 2 3 4 5 6 7 8 9 10 11 12 13 14 15 cm

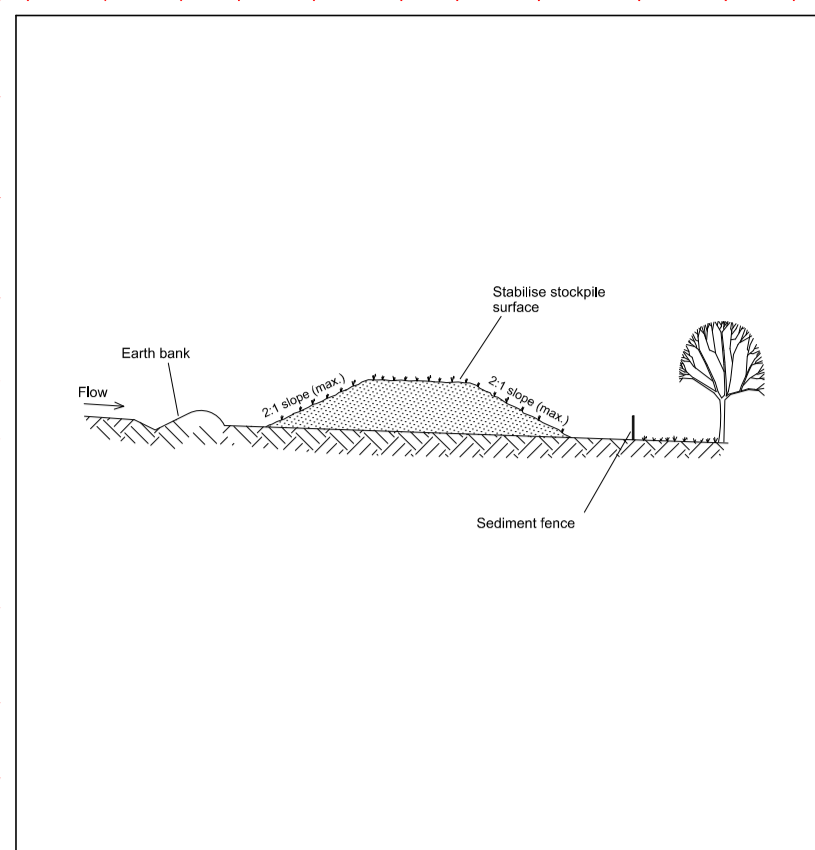

Construction Notes

- Place stockpiles more than 2 (preferably 5) metres from existing vegetation, concentrated water flow, roads and hazard areas.
- Construct on the contour or low, flat, elongated mounds.
- Where there is sufficient area, topsoil stockpiles shall be less than 2 metres in height.
- Where they are to be in place for more than 10 days, stabilise following the approved ESCP or SWMP to reduce the CA factor to less than 0.10.
- Construct earth banks (Standard Drawing 5-5) on the upslope side to divert water around stockpiles and sediment fences (Standard Drawing 6-8) 1 to 2 metres downslope.

STOCKPILES SD 4-1

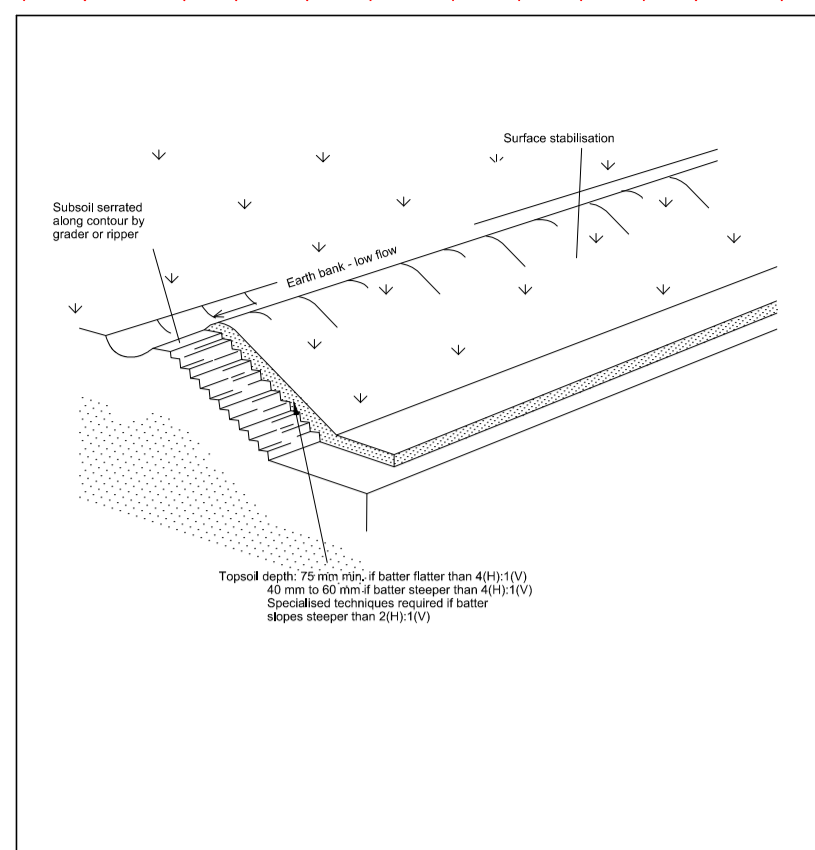

Construction Notes

- Scarify the ground surface along the line of the contour to a depth of 50 mm to 100 mm to break up any hardsetting surfaces and to provide a good bond between the respraid material and subsoil.
- Add soil ameliorants as required by the ESCP or SWMP.
- Rip to a depth of 300 mm of compacted layers.
- Where possible, replace topsoil to a depth of 40 to 60 mm on lands where the slope exceeds 4(H):1(V) and to at least 75 mm on lower gradients.

REPLACING TOPSOIL SD 4-2

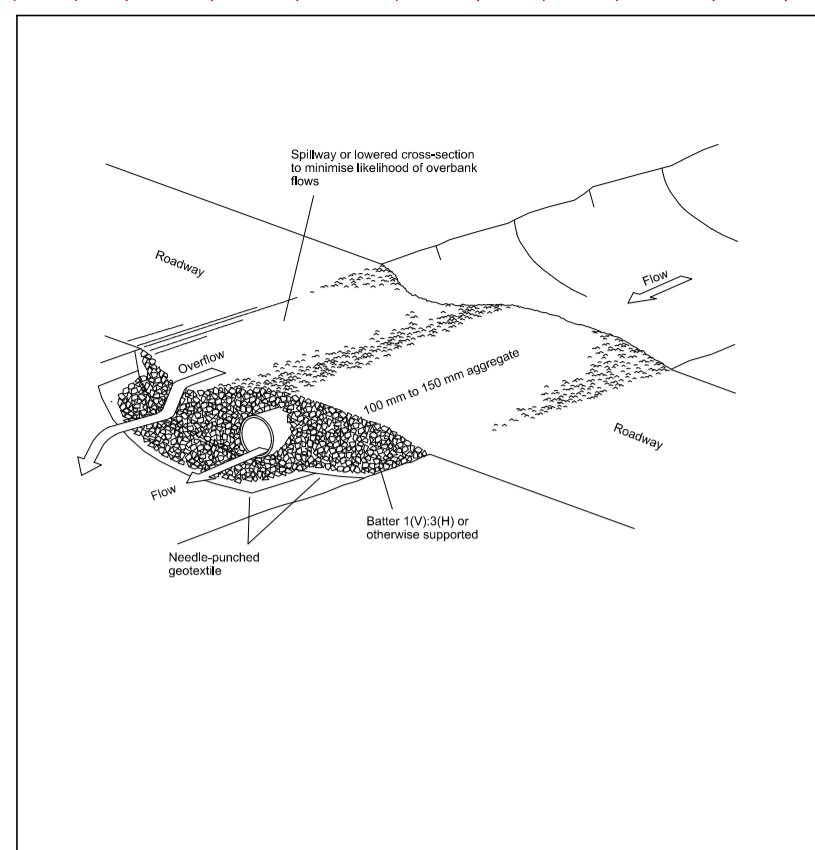

Construction Notes

- Prohibit all traffic until the access way is constructed.
- Strip any topsoil and place a needle-punched geotextile over the base of the crossing.
- Place clean, rigid, non-potting aggregate or gravel in the 100 mm to 150 mm size class over the fabric to a minimum depth of 200 mm.
- Provide a 3-metre wide carriageway with sufficient length of culvert pipe to allow less than a 3(H):1 (V) slope on side batters.
- Install a lower section to act as an emergency spillway in greater than 4(H):1(V) and to at least 75 mm on lower gradients.
- Ensure that culvert outlets extend beyond the toe of the fill embankments.

TEMPORARY WATERWAY CROSSING SD 5-1

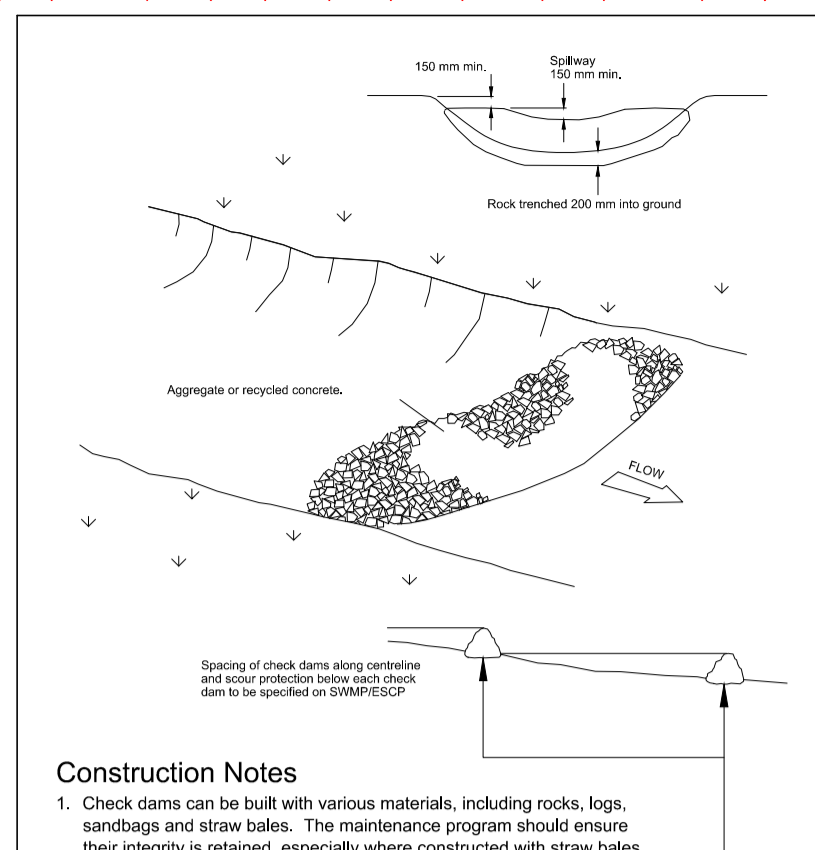

Construction Notes

- Check dams can be built with various materials, including rocks, logs, sandbags and straw bales. The maintenance program should ensure their integrity is retained, especially where constructed with straw bales. In the case of bales, this might require their replacement each two to four months.
- Trench the check dam 200 mm into the ground across its whole width. Where rock is used, fill the trenches to at least 100 mm above the ground surface to reduce the risk of undercutting.
- Normally, their maximum height should not exceed 600 mm above the gully floor. The centre should act as a spillway, being at least 150 mm lower than the outer edges.
- Space the dams so the toe of the upstream dam is level with the spillway of the next downstream dam.

ROCK CHECK DAM SD 5-4

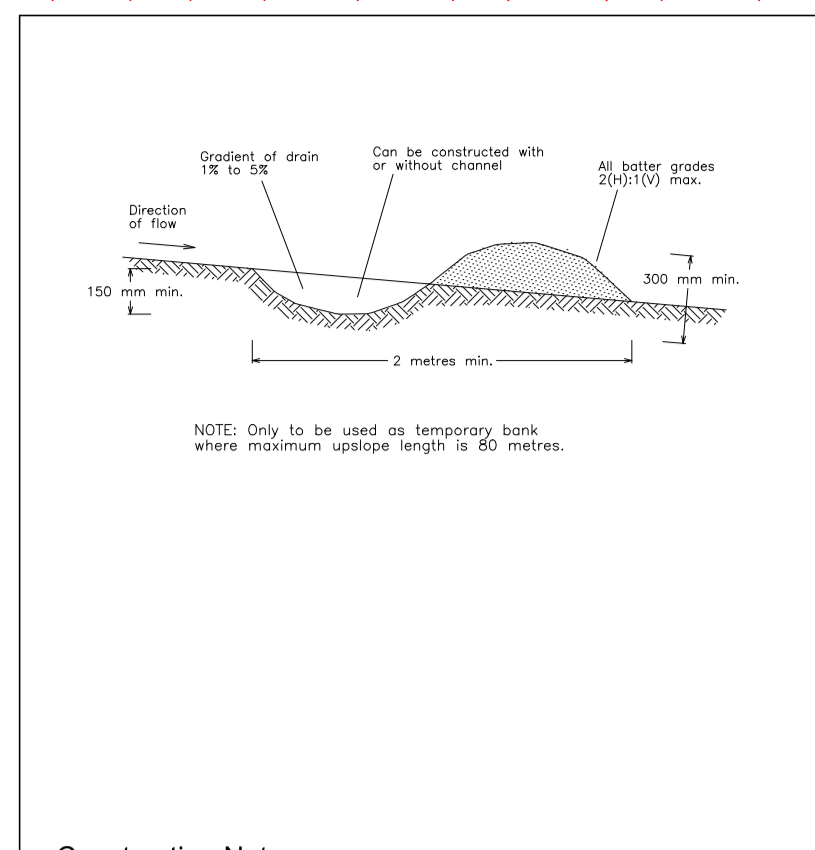

Construction Notes

- Build with gradients between 1 percent and 5 percent.
- Avoid removing trees and shrubs if possible - work around them.
- Ensure the structures are free of projections or other irregularities that could impede water flow.
- Build the drains with circular, parabolic or trapezoidal cross sections, not V-shaped.
- Ensure the banks are properly compacted to prevent failures.
- Complete permanent or temporary stabilisation within 10 days of construction.

EARTH BANK (LOW FLOW) SD 5-5

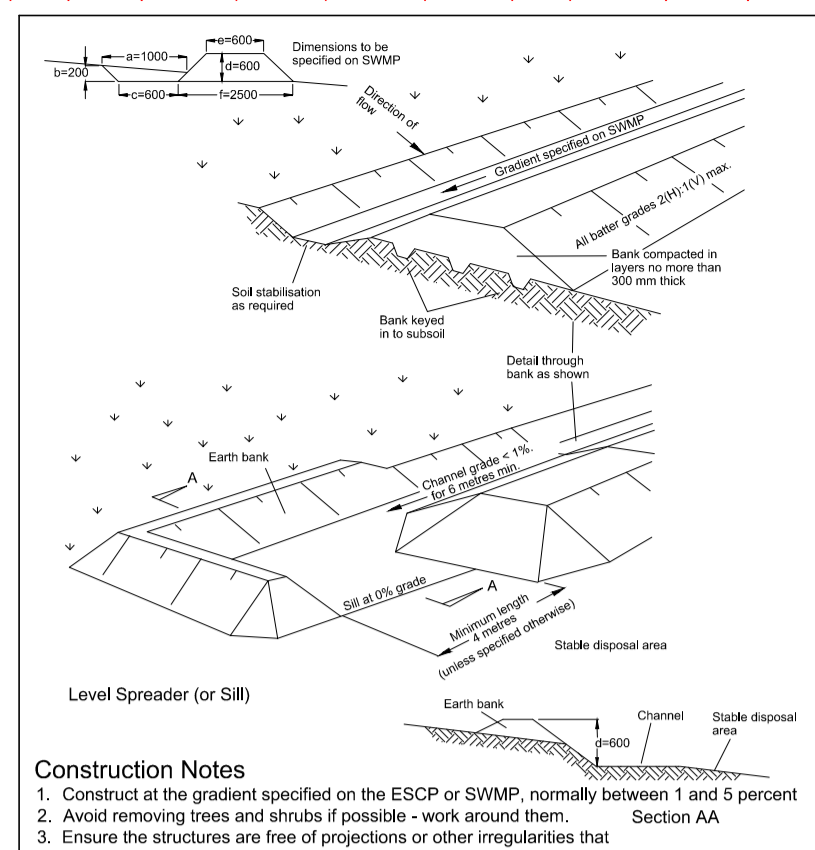

Construction Notes

- Construct at the gradient specified on the ESCP or SWMP, normally between 1 and 5 percent.
- Avoid removing trees and shrubs if possible - work around them. If they could impede water flow, ensure the structures are free of projections or other irregularities that could impede water flow.
- Build the drains with circular, parabolic or trapezoidal cross sections, not V-shaped, at the dimensions shown on the SWMP.
- Ensure the banks are properly compacted to prevent failure.
- Complete permanent or temporary stabilisation within 10 days of construction following Table 5.2 of Landcom (2004).
- Where discharging to erodible lands, ensure they outlet through a properly constructed level spreader.
- Construct the level spreader at the gradient specified on the ESCP or SWMP, normally less than 1 percent or level.
- Where possible, ensure they discharge waters onto either stabilised or undisturbed disposal sites within the same subcatchment area from which the water originated. Approval might be required to discharge into other subcatchments.

EARTH BANK (HIGH FLOWS) SD 5-6

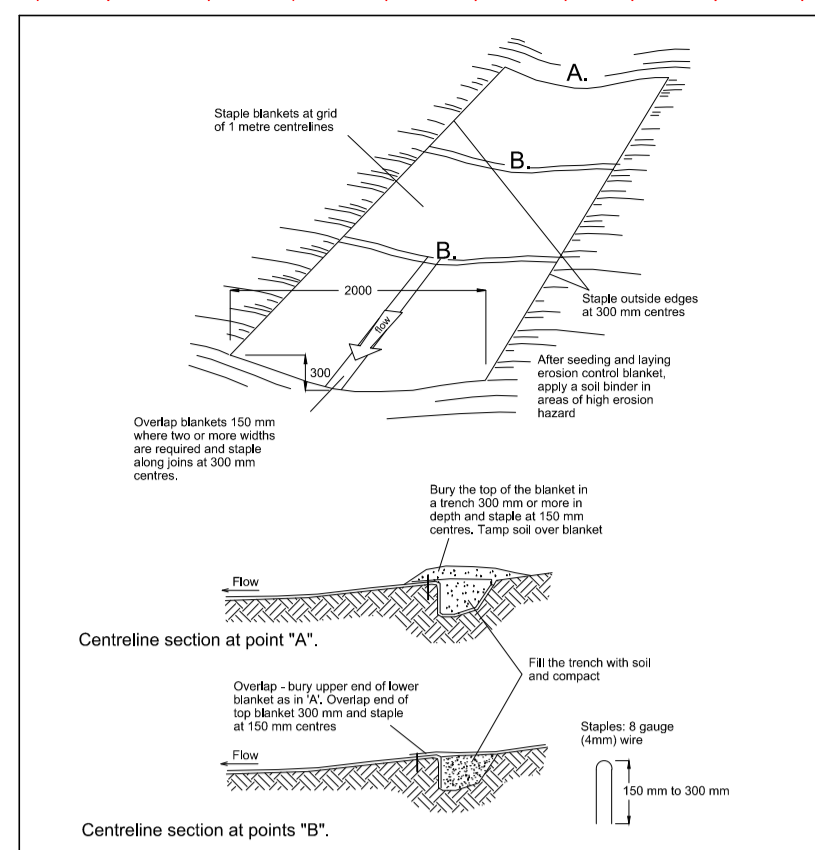

Construction Notes

- Remove any rocks, clods, sticks or grass from the surface before laying matting.
- Ensure that topsoil is at least 75 mm deep.
- Complete fertilising and seeding before laying the matting.
- Ensure fabric will be continuously in contact with the soil by grading the surface carefully first.
- Lay the fabric in "single-fashion", with the end of each upstream roll overlapping those downstream. Ensure each roll is anchored properly at its upslope end.
- Ensure that the full width of flow in the channel is covered by the matting up to the design storm event, usually in the 10-year ARI time of concentration storm event.
- Divert water from the structure until vegetation is stabilised properly.

RECP : CONCENTRATED FLOW SD 5-7

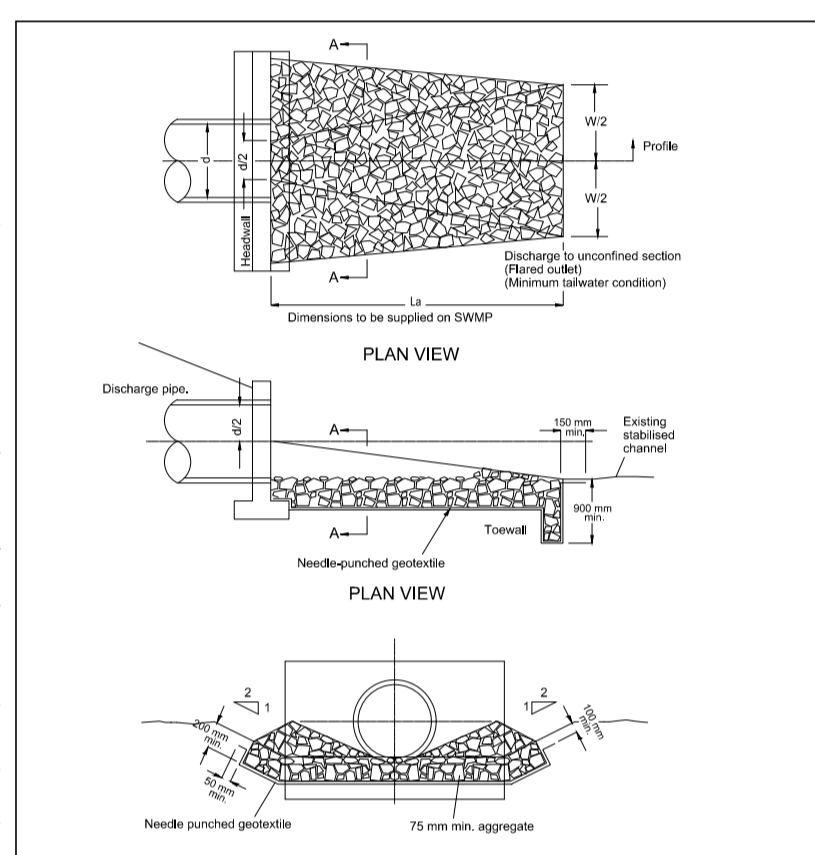

Construction Notes

- Compact the subgrade fill to the density of the surrounding undisturbed material.
- Prepare a smooth, even foundation for the structure that will ensure that the needle-punched geotextile does not sustain serious damage from spreading any aggregate. For repairs, patch one piece of fabric over the damage, making sure that all joints and patches overlap more than 300 mm.
- Lay rock following the drawing, according to Table 5.2 of Landcom (2004) and with a minimum diameter of 75 mm.
- Ensure that any concrete or riprap used for the energy dissipater or the outlet protection conforms to the grading limits specified on the SWMP.

ENERGY DISSIPATER SD 5-8

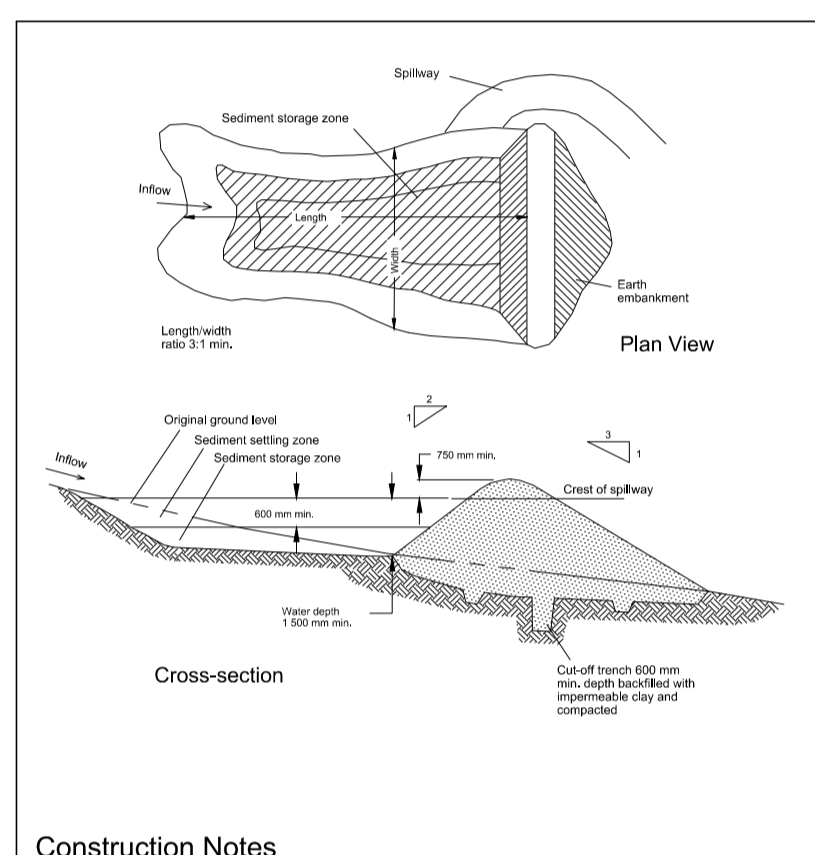

Construction Notes

- Remove all vegetation and topsoil from under the dam wall and from within the storage area.
- Construct a cut-off trench 500 mm deep and 1200 mm wide along the centreline of the embankment extending to a point on the gully wall level with the riser crest.
- Maintain the trench free of water and recompact the materials with equipment as specified in the SWMP to 95 per cent Standard Proctor Density.
- Select fill following the SWMP that is free of roots, wood, rock, large stone or foreign material.
- Prepare the site under the embankment by ripping to, at least 100 mm to help bond compacted fill to the existing substrate.
- Spread the fill in 100 mm to 150 mm layers and compact it at optimum moisture content following the SWMP.
- Construct the emergency spillway.
- Rehabilitate the structure following the SWMP.

EARTH BASIN - WET SD 6-4

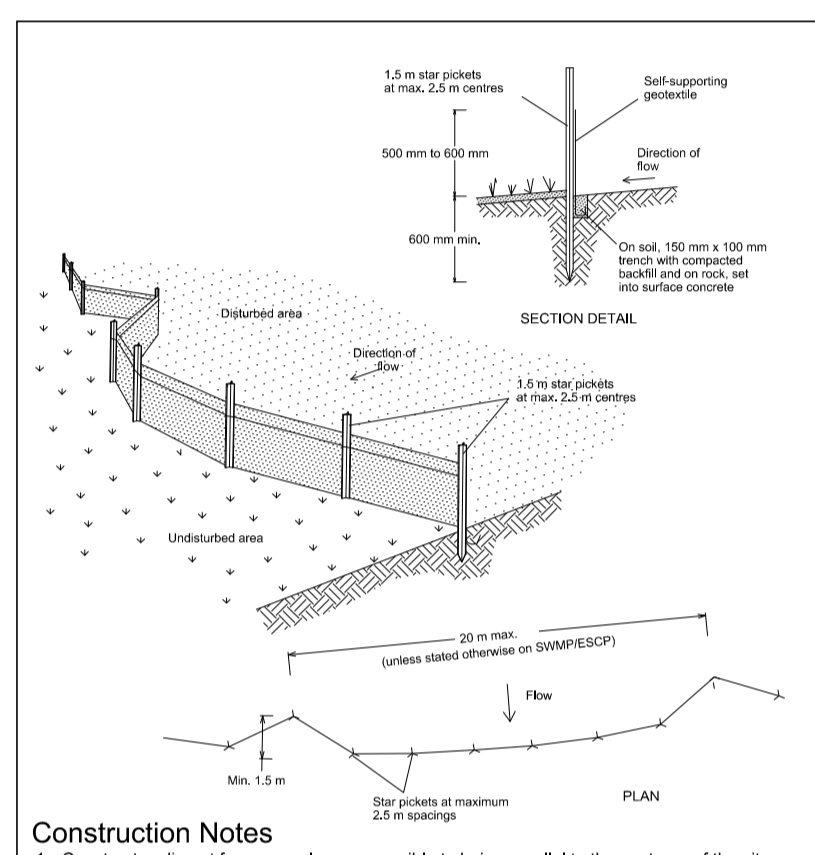

Construction Notes

- Construct sediment fences as close as possible to being parallel to the contours of the site, but with small returns as shown in the drawing to limit the catchment area of any one section. The catchment area should be small enough to limit water flow if concentrated at one point to 50 litres per second in the design storm event, usually the 10-year event.
- Cut a 150-mm deep trench along the upslope line of the fence for the bottom of the fabric to be entrenched.
- Drive 1.5 metre long star pickets into ground at 2.5 metre intervals (max) at the downslope edge of the trench. Ensure any star pickets are fitted with safety caps.
- Fix self-supporting geotextile to the upslope side of the posts ensuring it goes to the base of the trench. Fix the geotextile with wire ties or as recommended by the manufacturer. Only use geotextile specifically produced for sediment fencing. The use of shade cloth for this purpose is not satisfactory.
- Join sections of fabric at a support post with a 150-mm overlap.
- Backfill the trench over the base of the fabric and compact it thoroughly over the geotextile.

SEDIMENT FENCE SD 6-8

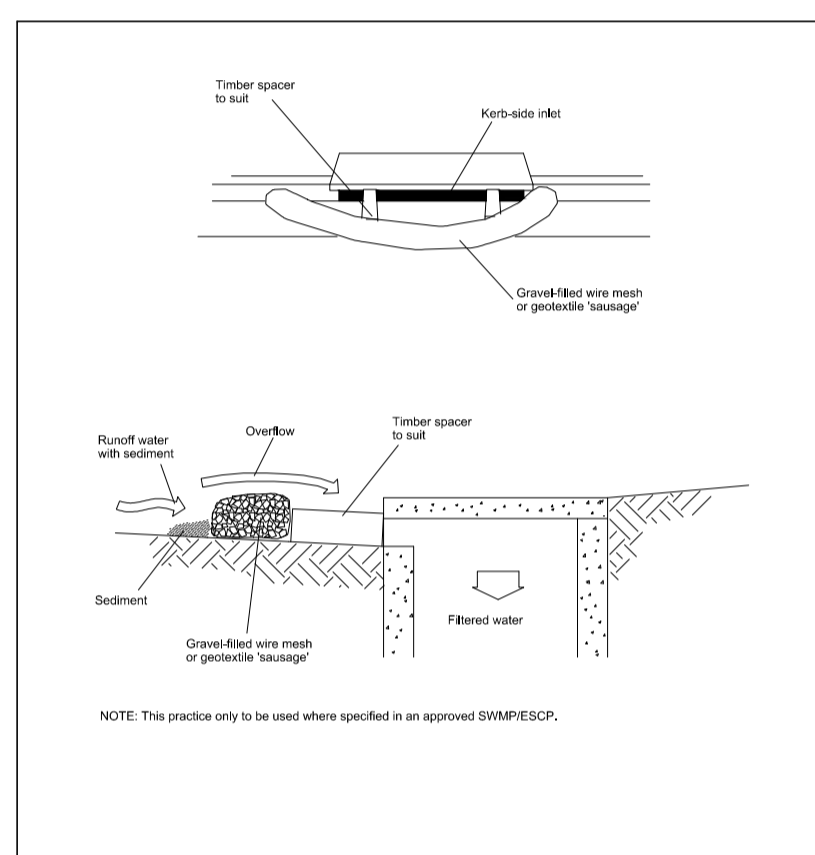

Construction Notes

- Install filters to keep debris out at sag points.
- Fabricate a sleeve made from geotextile or wire mesh longer than the length of the inlet pit and fill it with 25 mm to 50 mm gravel.
- Form an elliptical cross-section about 150 mm high x 400 mm wide.
- Place the filter at the opening leaving at least a 100-mm space between it and the kerb side. Maintain the opening with spacers.
- Form a seal with the kerb to prevent sediment bypassing the filter.
- Sandbags filled with gravel can substitute for the mesh or geotextile providing they are placed so that they firmly abut each other and sediment-laden waters cannot pass between.

MESH AND GRAVEL INLET FILTER SD 6-11

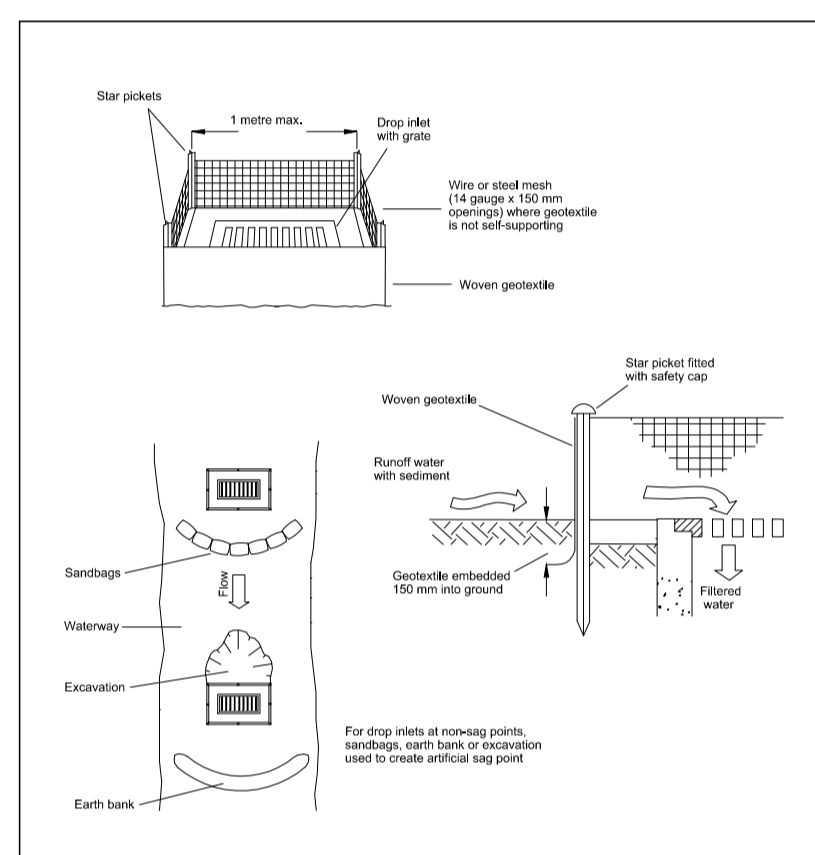

Construction Notes

- Fabricate a sediment barrier made from geotextile or straw bales.
- Follow Standard Drawing 6-8 for installation procedures for the straw bales or geotextile. Reduce the pocket spacing to 1 metre centres.
- In waterways, artificial sag points can be created with sandbags or earth banks as shown in the drawing.
- Do not cover the inlet with geotextile unless the design is adequate to allow for all waters to bypass it.

GEOTEXTILE INLET FILTER SD 6-12

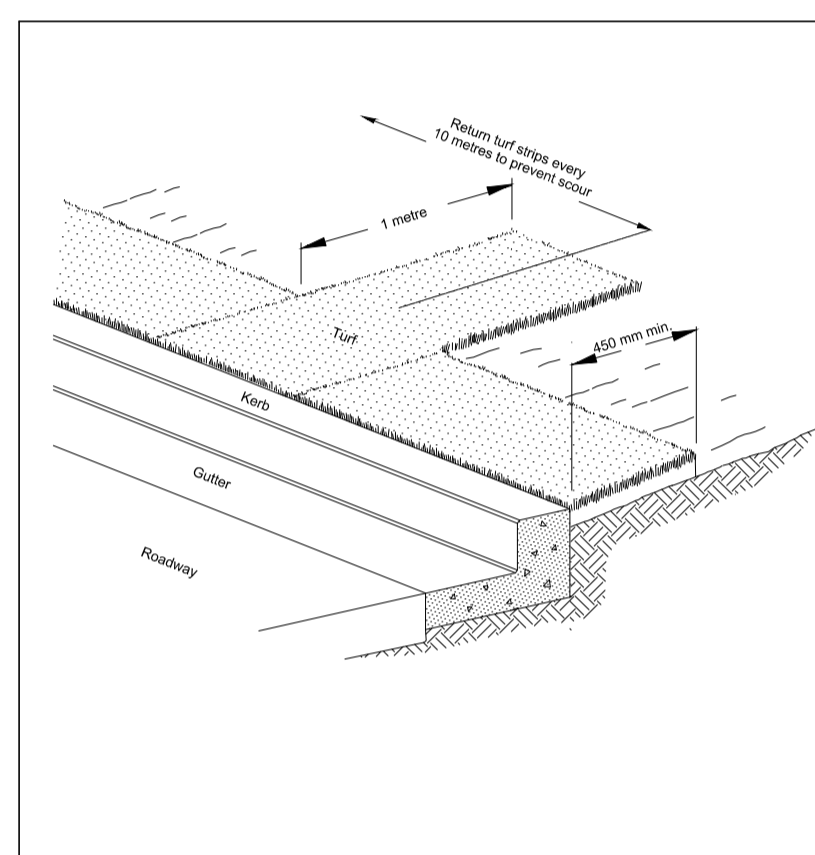

Construction Notes

- Install a 450 mm minimum wide roll of turf on the footpath next to the kerb and at the same level as the top of the kerb.
- Lay 1.4 metre long turf strips normal to the kerb every 10 metres.
- Rehabilitate disturbed soil behind the turf strip following the ESCP/SWMP.

KERBSIDE TURF STRIP SD 6-13

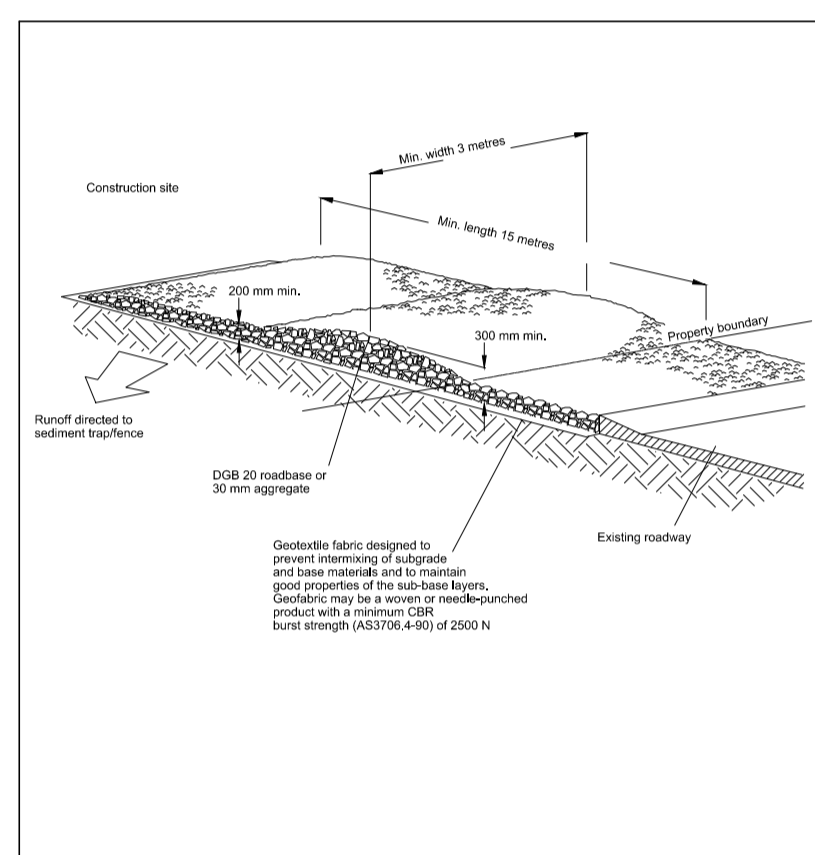

Construction Notes

- Strip the topsoil, level the site and compact the subgrade.
- Cover the area with needle-punched geotextile.
- Construct a 200 mm thick pad over the geotextile using road base or 30 mm aggregate.
- Ensure the structure is at least 15 metres long or to building alignment and at least 3 metres wide.
- Where a sediment fence joins onto the stabilised access, construct a hump in the stabilised access to divert water to the sediment fence.

STABILISED SITE ACCESS SD 6-14

SOIL AND WATER MANAGEMENT DETAILS

EROSION AND SEDIMENTATION CONTROL NOTES:

The following notes may not be relevant to all development.

GENERAL

- ESCP refers to Erosion and Sediment Control Plan or a Soil and Water Management Plan (SWMP).
- ESCP refers to erosion and sediment control.
- Sediment, includes, but is not limited to, clay, silt, sand, gravel, soil, mud, cement, and ceramic waste.
- Any reference to the Blue Book refers to Managing Urban Stormwater - Soils and Construction, Landcom, 2004.
- Any reference to the ICA White Book (2008) Best Practice Erosion and Sediment Control, Books 1-6, International Erosion Control Association (Australia), Picton NSW.
- Any material deposited in any conservation area from works associated with the development shall be removed immediately by measures involving minimal ground and/or vegetation disturbance and no machinery, or following directions by Council and/or within a timeframe advised by Council.

THE ESCP

- The ESCP and its associated ESC measures shall be constantly monitored, reviewed, and modified as required to correct deficiencies. Council has the right to direct changes if, in its opinion, the measures that are proposed or have been installed are inadequate to prevent pollution.
- Prior to any activities onsite, the responsible person(s) is to be nominated. The responsible person(s) shall be responsible for the ESC measures onsite. The name, address and 24 hour contact details of the person(s) shall be provided to Council in writing. Council shall be advised within 48 hours of any changes to the responsible person(s), or their contact details, in writing.
- At least 14 days before the natural surface is disturbed in any new stage, the contractor shall submit to the Certifier, a plan showing ESC measures for that Stage. The degree of design detail shall be based on the disturbed area.
- At any time during construction, the ESC measures onsite shall be appropriate for the area of disturbance and its characteristics including soils (in accordance with those required for the site as per DCP).
- The implementation of the ESCP shall be supervised by personnel with appropriate qualifications and/or experience in ESC on construction sites.
- The approved ESCP shall be available on-site for inspection by Council officers while work activities are occurring.
- The approved ESCP shall be up to date and show a timeline of installation, maintenance and removal of ESC measures.
- All ESC measures shall be appropriate for the Sediment Type(s) of the soils onsite, in accordance with the Blue Book, ICA White Books or other current recognised industry standard for ESC for Australia conditions.
- Adequate site data, including soil data from a NATA approved Laboratory, shall be obtained to allow the preparation of an appropriate ESCP, and allow the selection, design and specification of required ESC measures.
- All works shall be carried out in accordance with the approved ESCP (as amended from time to time) unless circumstances arise where:
 - compliance with the ESCP would increase the potential for environmental harm; or
 - circumstances change during construction and those circumstances could not have been foreseen; or
 - Council determines that unacceptable off-site sedimentation is occurring as a result of a land-disturbing activity. In either case, the person(s) responsible may be required to take additional, or alternative protective action, and/or undertake responsible restoration works within the timeframe specified by the Council.
- Additional ESC measures shall be implemented, and a revised ESCP submitted for approval to the certifier (within five business days of any such amendments) in the event that:
 - there is a high probability that serious or material environmental harm may occur as a result of sediment leaving the site; or
 - the implemented works fail to achieve Council's water quality objectives specified in these conditions; or
 - site conditions significantly change; or
 - the implemented works fail to achieve Council's water quality objectives specified in these conditions; or
 - site conditions significantly change; or
 - site inspections indicate that the implemented works are failing to achieve the 'objective' of the ESCP.
- A copy of any amended ESCP shall be forwarded to an appropriate Council Officer, within five business days of any such amendments.

SITE ESTABLISHMENT INCLUDING CLEARING AND MULCHING

- No land clearing shall be undertaken unless preceded by the installation of adequate drainage and sediment control measures, unless such clearing is required for the purpose of installing such measures, in which case, only the minimum clearing required to install such measures shall occur.
- Bulk tree clearing and grubbing of the site shall be immediately followed by specified temporary erosion control measures (e.g. temporary grassing or mulching) prior to commencement of each stage of construction works.
- Trees and vegetation cleared from the site shall be mulched onsite within 7 days of clearing.
- Appropriate measures shall be undertaken to control any dust originating due to the mulching of vegetation onsite.
- All effluent facilities and operational activities shall be located such that any effluent, including wash-down water, can be totally contained and treated within the site.
- All reasonable and practicable measures shall be taken to ensure stormwater runoff from access roads and stabilised entry/exit systems, drains to an appropriate sediment control device.
- Site exit points shall be appropriately managed to minimise the risk of sediment being tracked onto sealed, public roadways.
- Stormwater runoff from access roads and stabilised entry/exit points shall drain to an appropriate sediment control device.
- All sites shall ensure an adequate supply of ESC, and appropriate pollution clean-up materials are available on-site at all times.
- All temporary earth banks, flow diversion systems, and sediment basin embankments shall be machine-compact, seeded and mulched within ten (10) days of formation for the purpose of establishing a vegetative cover, or lined appropriately.
- Sediment deposited off site as a result of on-site activities shall be collected and the area cleaned/rehabilitated as soon as reasonable and practicable.
- Concrete waste and chemical products, including petroleum and oil-based products, shall be prevented from entering any internal or external water body, or any external drainage system, excluding those on-site water bodies specifically designed to contain and/or treat such material. Appropriate measures shall be installed to trap these materials onsite.
- Brick, tile or masonry cutting shall be carried out on a previous surface (e.g. grass or open soil) and in such a manner that any resulting sediment-laden runoff is prevented from discharging into a gutter, drain or water. Appropriate measures shall be installed to trap these materials onsite.
- Newly sealed hard-stand areas (e.g. roads, driveways and car parks) shall be swept thoroughly as soon as practicable after sealing/surfacing to minimise the risk of components of the surfacing compound entering stormwater drains.
- Stockpiles of erodible material shall be provided with an appropriate protective cover (synthetic or organic) if the materials are likely to be stockpiled for more than 10 days.
- Stockpiles, temporary or permanent, shall not be located in areas identified as no-go zones (including, but not limited to, restricted access areas, buffer zones, or areas of non-disturbance) on the ESCP.
- No more than 150m of a stormwater, sewer line or other service trench shall be open at any one time.
- Site spoil shall be lawfully disposed of in a manner that does not result in ongoing soil erosion or environmental harm.
- Wherever reasonable and practicable, stormwater runoff entering the site from external areas, and non-sediment laden (clean) stormwater runoff entering a work area or area of soil disturbance, shall be diverted around or through that area in a manner that minimises soil erosion and the contamination of that water for all discharges up to the specified design storm discharge.

SITE MANAGEMENT INCLUDING DUST

- Priority shall be given to the prevention, or at least the minimisation, of soil erosion, rather than the trapping of displaced sediment. Such a clause shall not reduce the responsibility to apply and maintain, at all times, all necessary ESC measures.
- Measures used to control wind erosion shall be appropriate for the location and prevent soil erosion at all times, including working hours, out of hours, weekends, public holidays, and during any other shutdown periods.
- The application of liquid or chemical-based dust suppression measures shall ensure that sediment-laden runoff resulting from such measures does not create a traffic or environmental hazard onsite.
- All cut and fill earth batters less than 3m in elevation shall be topsoiled, and grass seeded/hydrated within 10 days of completion of grading in consultation with Council.
- Once cut/fill operations have been finalised in a section, all disturbed areas that are not being worked on shall be stabilised in accordance with time lines in the Blue Book.
- All reasonable and practicable measures shall be taken to prevent, or at least minimise, the release of sediment from the site.
- 44 Suitable all-weather maintenance access shall be provided to all sediment control devices.
- Sediment control devices, other than sediment basins, shall be de-silted and made fully operational as soon as reasonable and practicable after a sediment-producing event, whether natural or artificial, if the device's sediment retention capacity falls below 75% of its design retention capacity.
- All erosion and sediment control measures, including drainage control measures, shall be maintained in proper working order at all times during their operational lives.
- Washing/flushing of sealed roadways shall only occur where sweeping has failed to remove sufficient sediment and there is a compelling need to remove the remaining sediment (e.g. for safety reasons). In such circumstances, all reasonable and practicable sediment control measures shall be used to prevent, or at least minimise, the release of sediment into receiving waters. Only those measures that will not cause safety and property flooding issues shall be employed. Sediment removed from roadways shall be disposed of in a lawful manner that does not cause ongoing soil erosion or environmental harm.
- Sediment removed from sediment traps and pieces of sediment deposition shall be disposed of in a lawful manner that does not cause ongoing soil erosion or environmental harm.

SEDIMENT BASINS - INSTALLATION, MAINTENANCE AND REMOVAL INCLUDING SEDIMENT TRAPS

- As-Constructed plans shall be prepared for all constructed Sediment Basins and associated emergency spillways. Such plans shall verify the basin's dimensions, levels and volumes comply with the approved design drawings. These plans may be requested by the Certifier or Council.
- Sediment basins shall be constructed and fully operational prior to any other soil disturbance in their catchment.
- Install on internal gated valve, or similar, in any outlet pipe once pipes installed, or install a sacrificial pipe from basin through wall to external outlet point. The valve shall be connected to a riser made from slotted pipe in the basin. The valve may be opened once captured water meets water quality requirements. The final setup for temporary internal outlet structures to be confirmed prior to construction with Council. This setup will enable discharge of treated water from site without need for pumping.
- A sediment control level marker post shall be with a cross member set just below the top of the sediment storage zone (as specified on the approved ESCP). At least a 75mm wide post shall be firmly set into the basin floor.
- All erosion and sediment control measures, including drainage control measures, shall be maintained in proper working order at all times during their operational lives.
- The Site Manager shall obtain the relevant approvals from the relevant organisations to discharge treated water from any existing basins. Organisations may include, but not be limited to, Hunter Water, and Council.
- Where more than one stage is to be developed at one time, or before the preceding stage is complete, the sediment basin(s) for these stages shall have sufficient capacity to cater for all area directed to the basin(s).
- Prior to any forecast weather event likely to result in runoff, any basins/traps shall be dewatered to provide sufficient capacity to capture sediment laden water from the site.
- Sufficient quantities of chemicals/agents to treat captured water shall be placed such that water entering the basin mixes with the chemical/agents and is carried into the basin to speed up clarification.
- Any basin shall be dewatered within the X-day rainfall depth used to calculate the capacity of the basin, after a rainfall event.
- Sufficient quantities of chemicals/agents to treat turbid water shall be securely stored on-site to provide for at least three complete treatments of all basins requiring chemical treatment onsite.

SEDIMENT BASINS - INSTALLATION, MAINTENANCE AND REMOVAL INCLUDING SEDIMENT TRAPS CONTD

- Prior to the controlled discharge (e.g. de-watering activities) from excavations and/or sediment basins, the following water quality objectives shall be achieved:
 - Total Suspended Solids (TSS) to a maximum 50mg/L;
 - water pH between 6.5 and 8.5, unless otherwise required by the Council;
 - Turbidity (measured in NTUs) to a maximum of 60 NTU; and
 - EC levels no greater than background levels.
- The Development Approval may require testing of additional water quality elements prior to discharge. E.g. heavy metals.
- A sample of the released treated water shall be kept onsite in a clear container with the sample date recorded on it.
- Water quality samples shall be taken at a depth no less than 200mm below the water surface of the basin.
- No Aluminium based products may be used to treat captured water onsite without the prior written permission from an appropriate Council Officer. The applicant shall have a demonstrated ability to use such products correctly and without environmental harm prior to any approval.
- The chemical/agent used in Type D and Type F basins to treat captured water captured in the basin shall be applied in concentrations sufficient to achieve Council's water quality objectives within the X-day rainfall depth used to calculate the capacity of the basin, after a rainfall event.
- All Manufacturers' instructions shall be followed for any chemicals/agents used onsite, except where approved by the Responsible Person or an appropriate Council Officer.
- The Applicant shall ensure that on each occasion a Type F or Type D basin was not de-watered prior to being surcharged by a following rainfall event, a report is presented to an appropriate Council officer within 5 days identifying the circumstances and proposed amendments, if any, to the basin's operating procedures.
- Settled sediment shall be removed as soon as reasonable and practicable from any sediment basin it:
 - is anticipated that the next storm event is likely to cause sediment to settle above the basin's sediment storage zone; or
 - the elevation of settled sediment is above the top of the basin's sediment storage zone; or
 - the elevation of settled sediment is above the basins sediment marker line.
- Scour protection measures placed on sediment basin emergency spillways shall appropriately protect the spillway chute and its side batters from scour, and shall extend a minimum of 3m beyond the downstream toe of the basin's embankment.
- Suitable all-weather maintenance access shall be provided to all sediment control devices.
- Materials, whether liquid or solid, removed from any ESC measures during maintenance or decommissioning, shall be disposed of in a manner that does not cause ongoing soil erosion or environmental harm.
- All sediment basins shall remain fully operational at all times until the basin's design catchment achieves 70% ground cover or surface stabilisation acceptable to Council.
- Suitable all-weather maintenance access shall be provided to all sediment control devices.
- Materials, whether liquid or solid, removed from any ESC measures during maintenance or decommissioning, shall be disposed of in a manner that does not cause ongoing soil erosion or environmental harm.
- All sediment basins shall not be decommissioned until all up-slope site stabilisation measures have been implemented and are appropriately working to control soil erosion and sediment runoff.
- Immediately prior to the construction of the permanent stormwater treatment device, appropriate flow bypass conditions shall be established to prevent sediment-laden water entering the device.

VEGETATION/STABILISATION

- 75 Temporary Stabilisation may be attained using vegetation, non rewettable soil polymers, or pneumatically applied erosion controls.
- All cut and fill earth batters less than 3m in elevation shall be topsoiled, and grass seeded/hydrated within 10 days of completion of grading in consultation with Council.
- Once cut/fill operations have been finalised in a section, all disturbed areas that are not being worked on shall be stabilised in accordance with time lines in the Blue Book.
- The LMKC Seed mix shall be used unless stated on the ESCP/SWMP.
- The pH level of topsoil shall be appropriate to enable establishment and growth of specified vegetation prior to initiating the establishment of vegetation.
- Non rewettable binder shall be used in all hydromulch/hydroseed/polymer mixes on slopes or works adjacent to a water course.
- Soil ameliorants shall be added to the soil in accordance with an approved Landscape Plan, Vegetation Management Plan, and/or soil analysis.
- Surface soil density, compaction and surface roughness shall be adjusted prior to seeding/planting in accordance with an approved Landscape Plan, Vegetation Management Plan, and/or soil analysis.
- Procedures for initiating a site shutdown, whether programmed or un-programmed, shall incorporate revegetation of all soil disturbances unless otherwise approved by Council. The stabilisation works shall not rely upon the longevity of non-vegetated erosion control blankets, or temporary soil binders.

SITE MONITORING AND MAINTENANCE

- The Applicant shall ensure that appropriate procedures and suitably qualified personnel are engaged to plan and conduct site inspections and water quality monitoring throughout the construction and maintenance phases.
- All ESC measures shall be inspected and any maintenance undertaken immediately:
 - at least daily (when work is occurring on-site); and
 - at least weekly (when work is not occurring on-site); and
 - within 24hrs of expected rainfall; and
 - within 10hrs of a rainfall event that causes runoff on the site.
- Written records shall be kept onsite of ESC monitoring and maintenance activities conducted during the construction and maintenance periods, and be available to Council officers on request.
- All environmentally relevant incidents shall be recorded in a field log that shall remain accessible to all relevant parties and be available on-site for inspection by [insert name of regulatory authority] on request.

INSTREAM WORKS

- All instream works (including in or adjacent to watercourses natural or manmade, flowing or not) shall be carried out in accordance with the ICA White Books.

SECTION 4.55 MODIFICATION "MOD 2" NOTES
 CHANGES TO THE CIVIL DRAWINGS FOR "MOD 2" GENERALLY COMPRISE THE FOLLOWING:
 • COORDINATION WITH AMENDED GENERAL ARCHITECTURAL ARRANGEMENT

DRAWING TO BE PRINTED IN COLOUR

NOT FOR CONSTRUCTION

6	REVISED DEVELOPMENT APPLICATION - MOD 2	3.12.25
5	REVISED DEVELOPMENT APPLICATION - MOD 1	3.9.25
4	REVISED DEVELOPMENT APPLICATION	25.8.22
3	DEVELOPMENT APPLICATION	19.8.22
2	PRELIMINARY DEVELOPMENT APPLICATION	12.8.22
1	COORDINATION	1.7.22
0	80% DA - CLIENT REVIEW	19.11.21

© Copyright MPC Consulting Engineers as date of issue

THIS DRAWING IS NOT TO BE USED FOR CONSTRUCTION UNLESS ENDORSED BELOW

COPYRIGHT

The concepts and information contained in this document are the copyright of MPC Consulting Engineers. Use or copying of the document in whole or in part without the written permission of MPC Consulting Engineers constitutes an infringement of copyright.

Level 1,
16 Telford Street,
NEWCASTLE EAST, NSW 2300
PO BOX 871
NEWCASTLE, NSW 2300
Tel: (02) 4927 5588
Email: admin@mpceng.com.au
Web: www.mpceng.com.au
A.C.N. 670 257 315

CLIENT
UNITING

TITLE
SOIL AND WATER MANAGEMENT DETAILS

PROJECT
PROPOSED UNITING DEVELOPMENT AT;
LOT 223, DP 551260,
No.27 TIRAL STREET,
CHARLESTOWN

DO NOT SCALE DRAWING

DRAWN	ENGINEER	No in SET	SHEET
J.D.L.	B.C.	-	A1
SCALES	JOB No	DRAWING No	ISSUE
N.T.S.	200243	00150	6

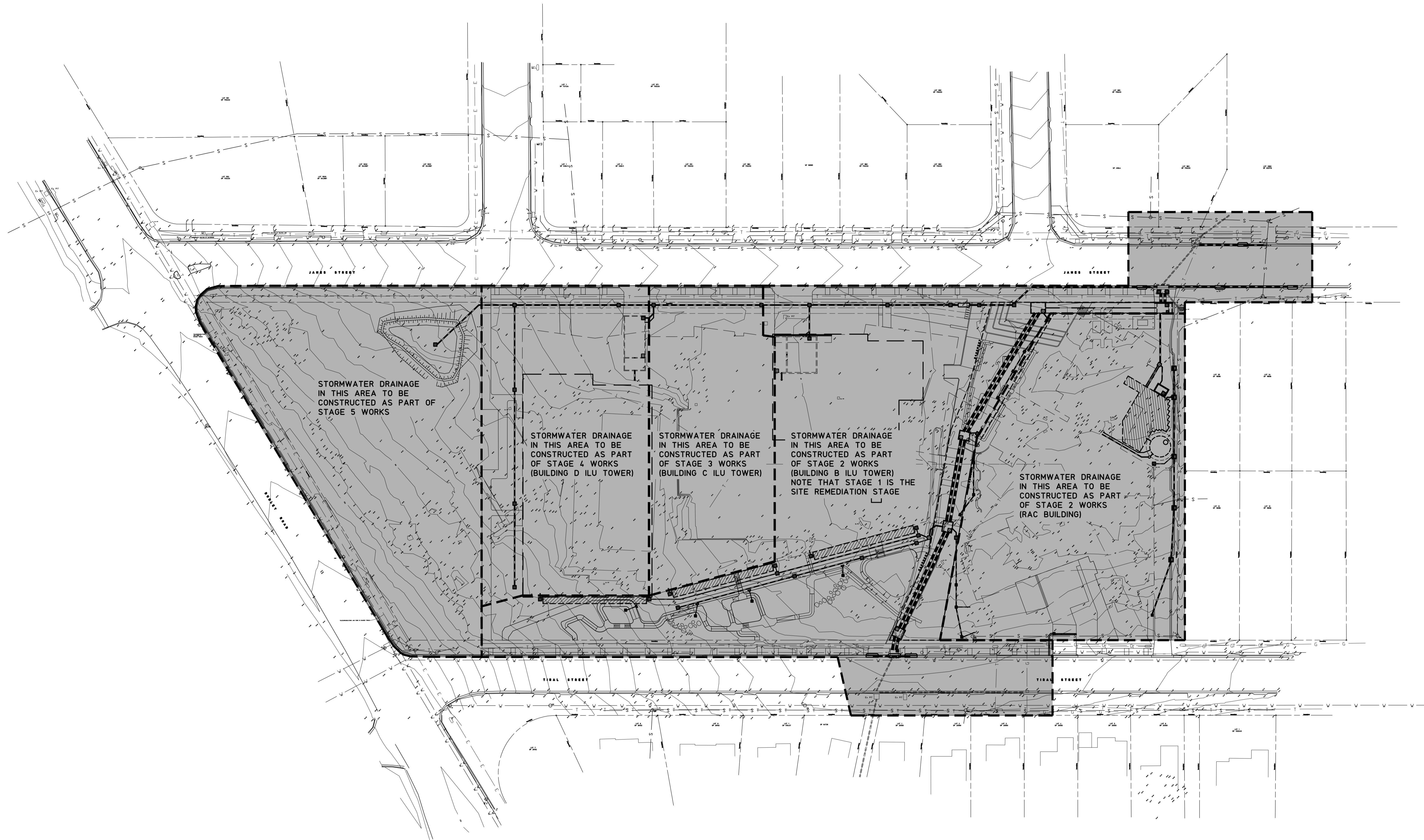

STORMWATER OVERALL STAGING PLAN

SCALE 1:500

NOT FOR CONSTRUCTION

SECTION 4.55 MODIFICATION "MOD 2" NOTES
 CHANGES TO THE CIVIL DRAWINGS FOR "MOD 2" GENERALLY COMPRISE THE FOLLOWING:
 • COORDINATION WITH AMENDED GENERAL ARCHITECTURAL ARRANGEMENT

DRAWING TO BE PRINTED IN COLOUR

9	REVISED DEVELOPMENT APPLICATION - MOD 2	3.12.25
8	REVISED DEVELOPMENT APPLICATION - MOD 1	1.10.25
7	REVISED DEVELOPMENT APPLICATION - MOD 1	3.9.25
6	REVISED DEVELOPMENT APPLICATION	25.8.22
5	DEVELOPMENT APPLICATION	19.8.22
4	PRELIMINARY DEVELOPMENT APPLICATION	12.8.22
3	COORDINATION	1.7.22
2	80% DA - CLIENT REVIEW	19.11.21
ISSUE	REASON FOR ISSUE	DATE

© Copyright MPC Consulting Engineers as date of issue	
THIS DRAWING IS NOT TO BE USED FOR CONSTRUCTION UNLESS ENDORSED BELOW	
RESPONSIBLE PRINCIPAL SIGNATURE	ISSUE

COPYRIGHT
 The concepts and information contained in this document are the copyright of MPC Consulting Engineers. Use or copying of the document in whole or in part without the written permission of MPC Consulting Engineers constitutes an infringement of copyright.

mpc
 consulting engineers
 civil+structural

Level 1,
 16 Telford Street,
 NEWCASTLE EAST, NSW 2300
 PO BOX 871
 NEWCASTLE, NSW 2300
 Tel: (02) 4927 5566
 Email: admin@mpceng.com.au
 Web: www.mpceng.com.au
 A.C.N. 670 257 315

CLIENT
UNITING

TITLE
STORMWATER OVERALL STAGING PLAN

PROJECT
**PROPOSED UNITING DEVELOPMENT AT;
 LOT 223, DP 551260,
 No.27 TIRAL STREET,
 CHARLESTOWN**

DO NOT SCALE DRAWING			
DRAWN J.D.L.	ENGINEER B.C.	No in SET -	SHEET A1
SCALES 1:500	JOB No 200243	DRAWING No 00200	ISSUE 9

FULL SIZE ON ORIGINAL 0 1 2 3 4 5 6 7 8 9 10 11 12 13 14 15 cm

STORMWATER PLAN SHEET 1

SCALE 1:100

STORMWATER NOTES

1. ALL WORKS TO BE IN ACCORDANCE WITH AS3500.3.
2. ALL PIPES TO HAVE A 1% MINIMUM FALL U.N.O.
3. ALL DOWNPIPES (DP) TO BE SPECIFIED BY ARCHITECT. FOR EXACT LOCATION OF DOWNPIPES, REFER TO ARCHITECTURAL DRAWINGS.
4. ALL PIPES TO BE UPVC U.N.O.
5. ALL UPVC PIPES TO BE SEWER GRADE AND TO AS1260.
6. ALL REINFORCED CONCRETE PIPES (RCP) TO BE SPIGOT AND SOCKET TYPE WITH RUBBER RINGS CLASS 2 TO AS4058.
7. PITS TO BE C&D REINFORCED PRE-CAST CONCRETE PITS OR EQUIVALENT PROPRIETARY PITS.
8. ALL LIDS AND GRATES TO BE PROPRIETARY HEAVY DUTY IN AREAS OF VEHICULAR TRAFFIC, LIGHT DUTY ELSEWHERE, IN ACCORDANCE WITH AS3996.
9. MINIMUM COVER TO STORMWATER PIPES TO BE AS FOLLOWS U.N.O.:
TRAFFICABLE AREAS - 450mm, LANDSCAPED AREAS - 300mm.
PIPES TO BE CONCRETE ENCASED IF MINIMUM COVERS CANNOT BE OBTAINED IN TRAFFICABLE AREAS, REFER TO CLAUSE 3.8 AS3500.3. ALTERNATIVELY USE UPVC SEWER GRADE PIPES UNDER ROAD AND BUILDINGS.
10. PROVIDE 100Φ AG DRAINS IN FILTER SOCKS TO ALL LANDSCAPED AREAS, PLANTER BEDS AND STORMWATER PIPE TRENCHES.
ALL AG DRAINS TO BE BEDDED IN COARSE AGGREGATE AND TO BE CONNECTED TO STORMWATER SYSTEM.
11. ALL PITS, DETENTION TANKS AND PROPRIETARY POLLUTION CONTROL DEVICES TO BE CLEANED OF SEDIMENT AT 3 MONTH MAXIMUM INTERVALS.
12. ALL EXISTING SERVICES TO BE LOCATED PRIOR TO COMMENCEMENT OF WORK.
13. ANY FOOTPATHS, KERB AND GUTTER OR ROADWAY DISTURBED BY WORKS TO BE REINSTATED TO CURRENT COUNCIL REQUIREMENTS.
14. PROVIDE ACCESS LADDER TO TANK AS REQUIRED, REFER TO AS1657.
15. REFER TO DRAWING 00212 FOR PIT SCHEDULE.

NOT FOR CONSTRUCTION

LEGEND

- DENOTES STORMWATER PIPE
- DENOTES EXISTING CONTOUR
- DENOTES EXISTING LEVEL
- DENOTES DESIGN SPOT LEVEL
- DENOTES KERB AND GUTTER
- DENOTES ROCK LINED SWALE 'RS1', REFER TO DRAWING 00261 FOR DETAILS
- DENOTES LOW-FLOW ROCK LINED SWALE 'RS2', REFER TO DRAWING 00261 FOR DETAILS
- DENOTES OVERLAND FLOW DIRECTION IN MAJOR STORM EVENT
- DENOTES DIRECTION OF SURFACE FLOWS
- DENOTES NON-RETURN VALVE TO PIPE AT THE PIT CONNECTION

NOTE
SETOUT AND ALIGNMENT OF WALLS TO BOUNDARY TO ARCHITECTS DETAILS TYPICAL

NOTE
ALL SETOUT, DIMENSIONS AND RL'S TO ARCHITECTS SPECIFICATION & DETAILS

NOTE
BUILDER TO PROVIDE ADEQUATE SHORING IN ORDER TO MAINTAIN STABILITY OF EXISTING NEIGHBOURING STRUCTURES AND FENCES DURING EXCAVATION WORKS TYPICAL

NOTE
DRIVEWAY GRADES TO CURRENT COUNCIL REQUIREMENTS. BUILDER TO CONFIRM GRADES PRIOR TO CONSTRUCTION OF DRIVEWAY

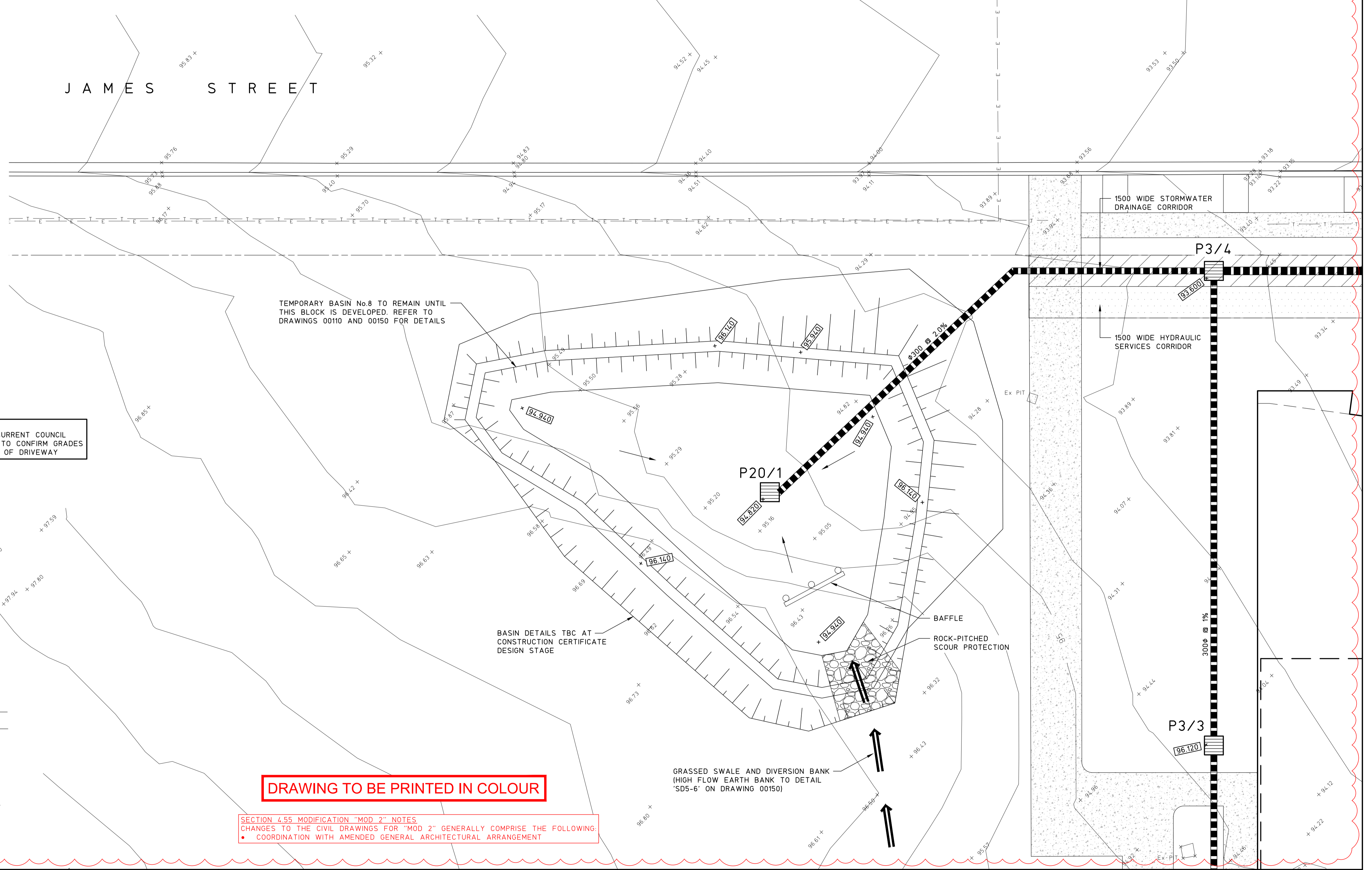

DRAWING TO BE PRINTED IN COLOUR

SECTION 4.55 MODIFICATION "MOD 2" NOTES
CHANGES TO THE CIVIL DRAWINGS FOR "MOD 2" GENERALLY COMPRISE THE FOLLOWING:
• COORDINATION WITH AMENDED GENERAL ARCHITECTURAL ARRANGEMENT

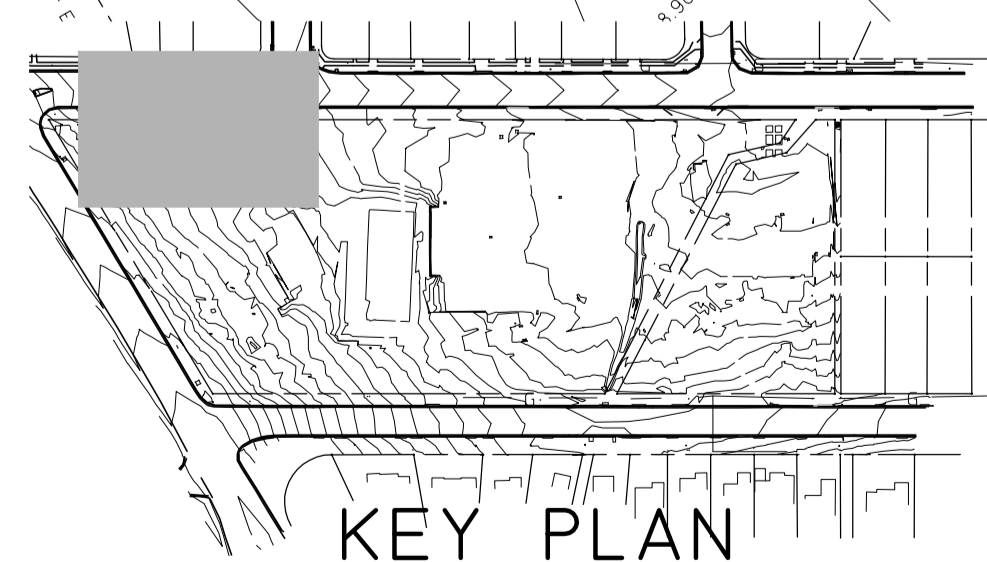

8	REVISED DEVELOPMENT APPLICATION - MOD 2	3.12.25			
7	REVISED DEVELOPMENT APPLICATION - MOD 1	3.9.25			
6	REVISED DEVELOPMENT APPLICATION	25.8.22			
5	DEVELOPMENT APPLICATION	19.8.22			
4	PRELIMINARY DEVELOPMENT APPLICATION	12.8.22			
3	COORDINATION	1.7.22			
2	80% DA - CLIENT REVIEW	19.11.21			
1	50% DA - CLIENT REVIEW	11.8.21			
ISSUE	REASON FOR ISSUE	DATE	DATE OF RELEASE	RESPONSIBLE PRINCIPAL SIGNATURE	ISSUE

© Copyright MPC Consulting Engineers as date of issue

THIS DRAWING IS NOT TO BE USED FOR CONSTRUCTION UNLESS ENDORSED BELOW

CLIENT
UNITING

TITLE
STORMWATER PLAN SHEET 1

PROJECT
**PROPOSED UNITING DEVELOPMENT AT;
LOT 223, DP 551260,
No.27 TIRAL STREET,
CHARLESTOWN**

DO NOT SCALE DRAWING

DRAWN J.D.L.	ENGINEER B.C.	No in SET -	SHEET A1
SCALES 1:100	JOB No 200243	DRAWING No 00201	ISSUE 8

© Copyright MPC Consulting Engineers as date of issue

CLIENT
UNITING

TITLE
STORMWATER PLAN SHEET 1

PROJECT
**PROPOSED UNITING DEVELOPMENT AT;
LOT 223, DP 551260,
No.27 TIRAL STREET,
CHARLESTOWN**

DO NOT SCALE DRAWING

DRAWN J.D.L.	ENGINEER B.C.	No in SET -	SHEET A1
SCALES 1:100	JOB No 200243	DRAWING No 00201	ISSUE 8

FULL SIZE ON ORIGINAL 0 1 2 3 4 5 6 7 8 9 10 11 12 13 14 15 cm

NOT FOR CONSTRUCTION

STORMWATER PLAN SHEET 2

SCALE 1:100

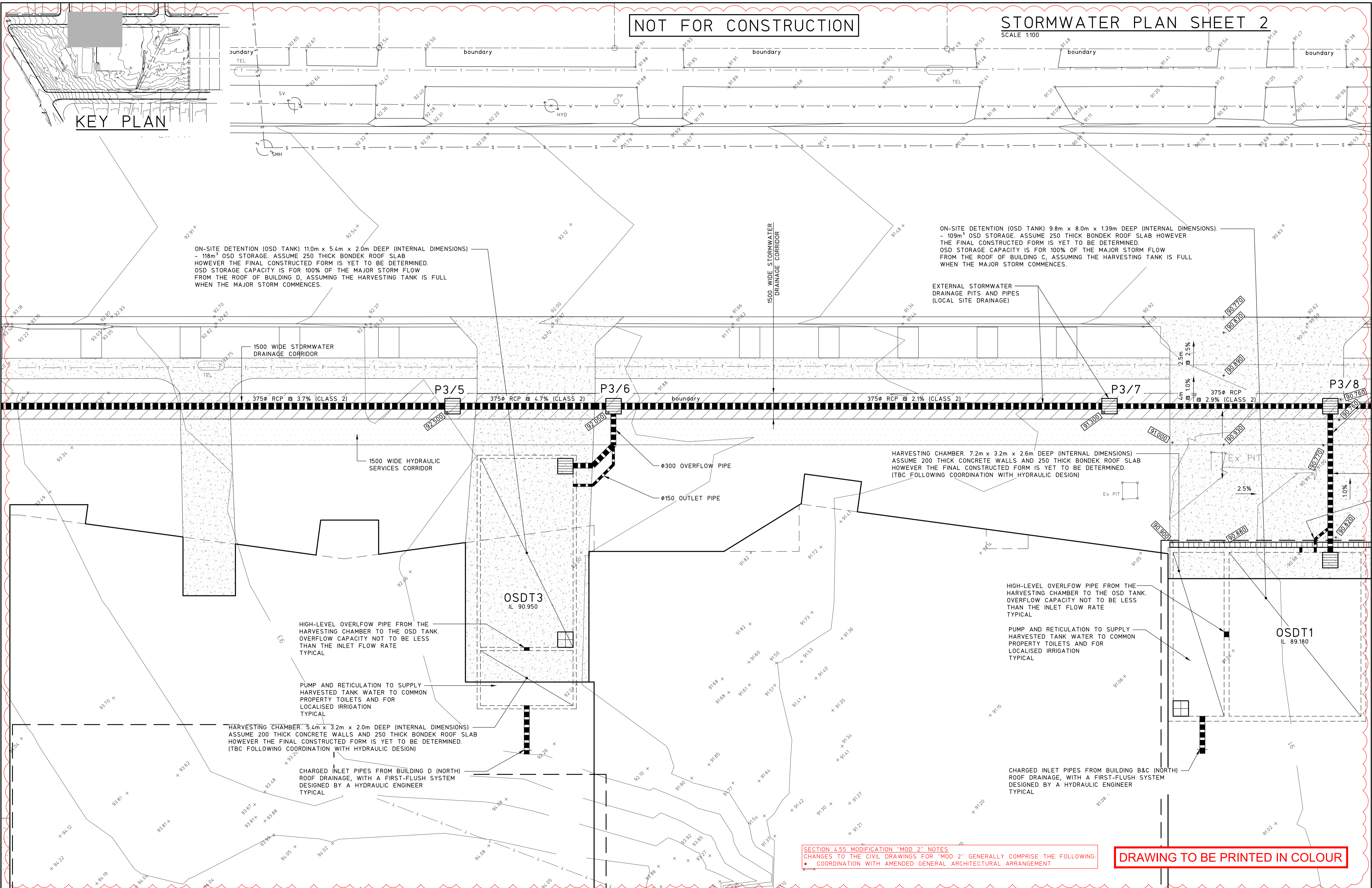

KEY PLAN

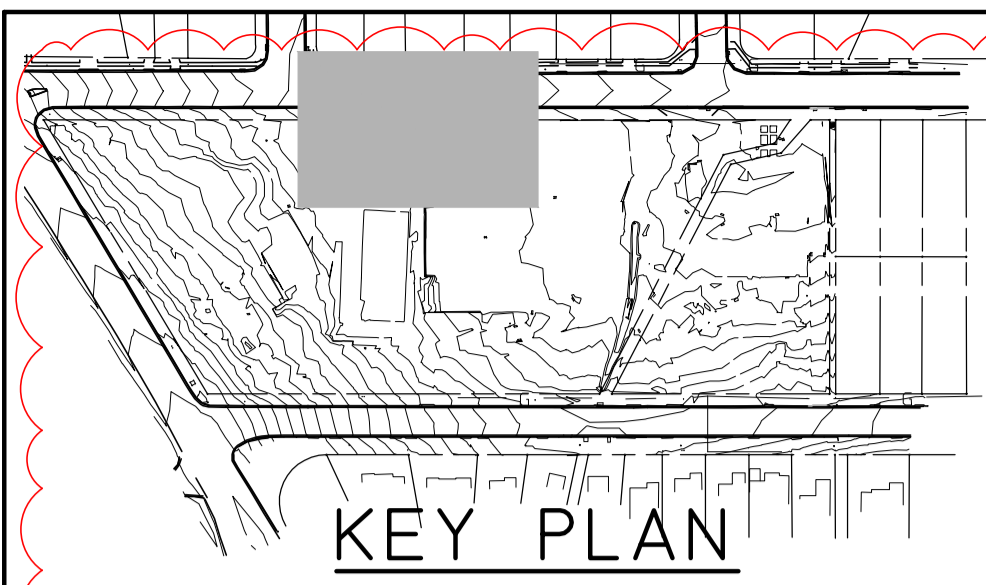

ON-SITE DETENTION (OSD TANK) 11.0m x 5.4m x 2.0m DEEP (INTERNAL DIMENSIONS)
 - 118m³ OSD STORAGE. ASSUME 250 THICK BONDEK ROOF SLAB
 HOWEVER THE FINAL CONSTRUCTED FORM IS YET TO BE DETERMINED.
 OSD STORAGE CAPACITY IS FOR 100% OF THE MAJOR STORM FLOW
 FROM THE ROOF OF BUILDING D, ASSUMING THE HARVESTING TANK IS FULL
 WHEN THE MAJOR STORM COMMENCES.

ON-SITE DETENTION (OSD TANK) 9.8m x 8.0m x 1.39m DEEP (INTERNAL DIMENSIONS).
 - 109m³ OSD STORAGE. ASSUME 250 THICK BONDEK ROOF SLAB HOWEVER
 THE FINAL CONSTRUCTED FORM IS YET TO BE DETERMINED.
 OSD STORAGE CAPACITY IS FOR 100% OF THE MAJOR STORM FLOW
 FROM THE ROOF OF BUILDING C, ASSUMING THE HARVESTING TANK IS FULL
 WHEN THE MAJOR STORM COMMENCES.

EXTERNAL STORMWATER
 DRAINAGE PITS AND PIPES
 (LOCAL SITE DRAINAGE)

HARVESTING CHAMBER 7.2m x 3.2m x 2.6m DEEP (INTERNAL DIMENSIONS)
 ASSUME 200 THICK CONCRETE WALLS AND 250 THICK BONDEK ROOF SLAB
 HOWEVER THE FINAL CONSTRUCTED FORM IS YET TO BE DETERMINED.
 (TBC FOLLOWING COORDINATION WITH HYDRAULIC DESIGN)

HIGH-LEVEL OVERFLOW PIPE FROM THE
 HARVESTING CHAMBER TO THE OSD TANK.
 OVERFLOW CAPACITY NOT TO BE LESS
 THAN THE INLET FLOW RATE
 TYPICAL

PUMP AND RETICULATION TO SUPPLY
 HARVESTED TANK WATER TO COMMON
 PROPERTY TOILETS AND FOR
 LOCALISED IRRIGATION
 TYPICAL

HARVESTING CHAMBER 5.4m x 3.2m x 2.0m DEEP (INTERNAL DIMENSIONS)
 ASSUME 200 THICK CONCRETE WALLS AND 250 THICK BONDEK ROOF SLAB
 HOWEVER THE FINAL CONSTRUCTED FORM IS YET TO BE DETERMINED.
 (TBC FOLLOWING COORDINATION WITH HYDRAULIC DESIGN)

CHARGED INLET PIPES FROM BUILDING D (NORTH)
 ROOF DRAINAGE, WITH A FIRST-FLUSH SYSTEM
 DESIGNED BY A HYDRAULIC ENGINEER
 TYPICAL

HIGH-LEVEL OVERFLOW PIPE FROM THE
 HARVESTING CHAMBER TO THE OSD TANK.
 OVERFLOW CAPACITY NOT TO BE LESS
 THAN THE INLET FLOW RATE
 TYPICAL

PUMP AND RETICULATION TO SUPPLY
 HARVESTED TANK WATER TO COMMON
 PROPERTY TOILETS AND FOR
 LOCALISED IRRIGATION
 TYPICAL

CHARGED INLET PIPES FROM BUILDING B&C (NORTH)
 ROOF DRAINAGE, WITH A FIRST-FLUSH SYSTEM
 DESIGNED BY A HYDRAULIC ENGINEER
 TYPICAL

SECTION 4.55 MODIFICATION "MOD 2" NOTES
 CHANGES TO THE CIVIL DRAWINGS FOR "MOD 2" GENERALLY COMPRISE THE FOLLOWING:
 • COORDINATION WITH AMENDED GENERAL ARCHITECTURAL ARRANGEMENT

DRAWING TO BE PRINTED IN COLOUR

9	REVISED DEVELOPMENT APPLICATION - MOD 2	3.12.25
8	REVISED DEVELOPMENT APPLICATION - MOD 1	1.10.25
7	REVISED DEVELOPMENT APPLICATION - MOD 1	3.9.25
6	REVISED DEVELOPMENT APPLICATION	25.8.22
5	DEVELOPMENT APPLICATION	19.8.22
4	PRELIMINARY DEVELOPMENT APPLICATION	12.8.22
3	COORDINATION	1.7.22
2	80% DA - CLIENT REVIEW	19.11.21
ISSUE	REASON FOR ISSUE	DATE

© Copyright MPC Consulting Engineers as date of issue

THIS DRAWING IS NOT TO BE USED FOR CONSTRUCTION UNLESS ENDORSED BELOW

DATE OF RELEASE	RESPONSIBLE PRINCIPAL SIGNATURE	ISSUE
-----------------	---------------------------------	-------

COPYRIGHT

The concepts and information contained in this document are the copyright of MPC Consulting Engineers. Use or copying of the document in whole or in part without the written permission of MPC Consulting Engineers constitutes an infringement of copyright.

Level 1,
 16 Telford Street,
 NEWCASTLE EAST, NSW 2300
 PO BOX 871
 NEWCASTLE, NSW 2300
 Tel: (02) 4927 5566
 Email: admin@mpceng.com.au
 Web: www.mpceng.com.au
 A.C.N. 670 257 315

CLIENT
UNITING

TITLE
STORMWATER PLAN SHEET 2

PROJECT
**PROPOSED UNITING DEVELOPMENT AT;
 LOT 223, DP 551260,
 No.27 TIRAL STREET,
 CHARLESTOWN**

DO NOT SCALE DRAWING

DRAWN J.D.L.	ENGINEER B.C.	No in SET -	SHEET A1
SCALES 1:100	JOB No 200243	DRAWING No 00202	ISSUE 9

NOT FOR CONSTRUCTION

STORMWATER PLAN SHEET 3

SCALE 1:100

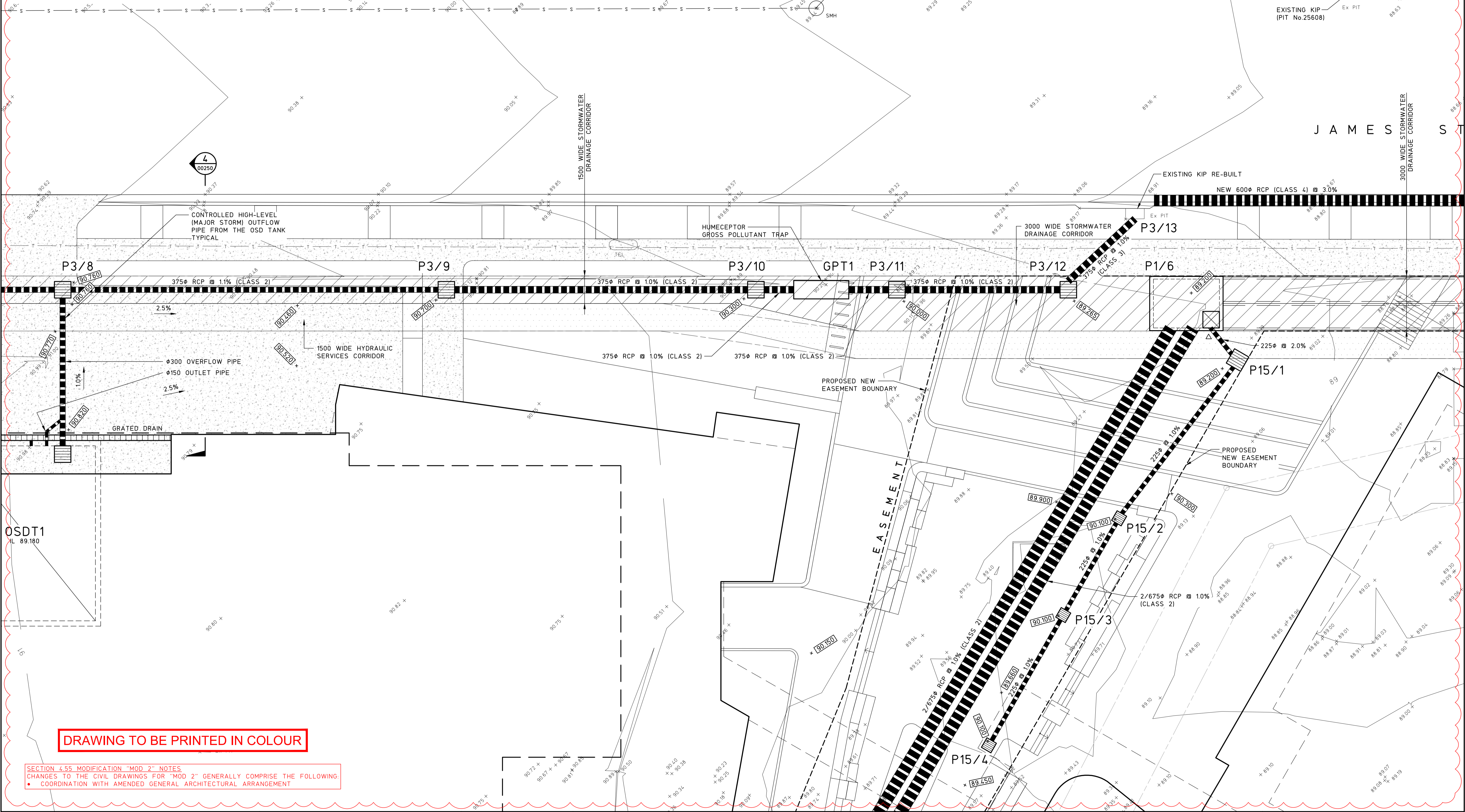
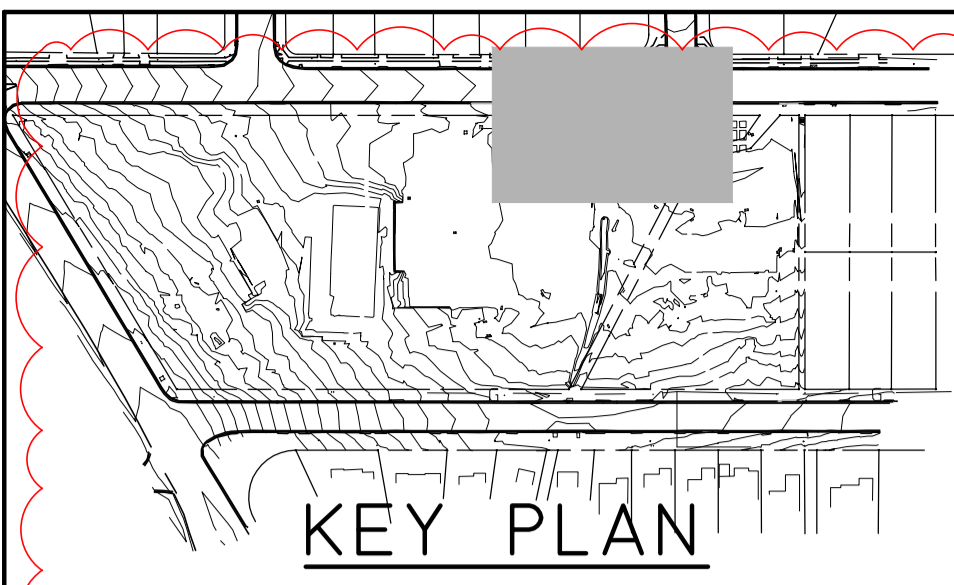

DRAWING TO BE PRINTED IN COLOUR

SECTION 4.55 MODIFICATION "MOD 2" NOTES
CHANGES TO THE CIVIL DRAWINGS FOR "MOD 2" GENERALLY COMPRISE THE FOLLOWING:
• COORDINATION WITH AMENDED GENERAL ARCHITECTURAL ARRANGEMENT

9	REVISED DEVELOPMENT APPLICATION - MOD 2	3.12.25
8	REVISED DEVELOPMENT APPLICATION - MOD 1	1.10.25
7	REVISED DEVELOPMENT APPLICATION - MOD 1	3.9.25
6	REVISED DEVELOPMENT APPLICATION - MOD 1	25.8.22
5	DEVELOPMENT APPLICATION	19.8.22
4	PRELIMINARY DEVELOPMENT APPLICATION	12.8.22
3	COORDINATION	1.7.22
2	80% DA - CLIENT REVIEW	19.11.21
ISSUE	REASON FOR ISSUE	DATE

© Copyright MPC Consulting Engineers as date of issue	
THIS DRAWING IS NOT TO BE USED FOR CONSTRUCTION UNLESS ENDORSED BELOW	
DATE OF RELEASE	RESPONSIBLE PRINCIPAL SIGNATURE

COPYRIGHT
The concepts and information contained in this document are the copyright of MPC Consulting Engineers. Use or copying of the document in whole or in part without the written permission of MPC Consulting Engineers constitutes an infringement of copyright.

Level 1,
16 Telford Street,
NEWCASTLE EAST, NSW 2300
PO BOX 871
NEWCASTLE, NSW 2300
Tel: (02) 4927 5566
Email: admin@mpceng.com.au
Web: www.mpceng.com.au
A.C.N. 670 257 315

CLIENT
UNITING

TITLE
STORMWATER PLAN SHEET 3

PROJECT
**PROPOSED UNITING DEVELOPMENT AT;
LOT 223, DP 551260,
No.27 TIRAL STREET,
CHARLESTOWN**

DO NOT SCALE DRAWING			
DRAWN J.D.L.	ENGINEER B.C.	No in SET -	SHEET A1
SCALES 1:100	JOB No 200243	DRAWING No 00203	ISSUE 9

FULL SIZE ON ORIGINAL 0 1 2 3 4 5 6 7 8 9 10 11 12 13 14 15 cm

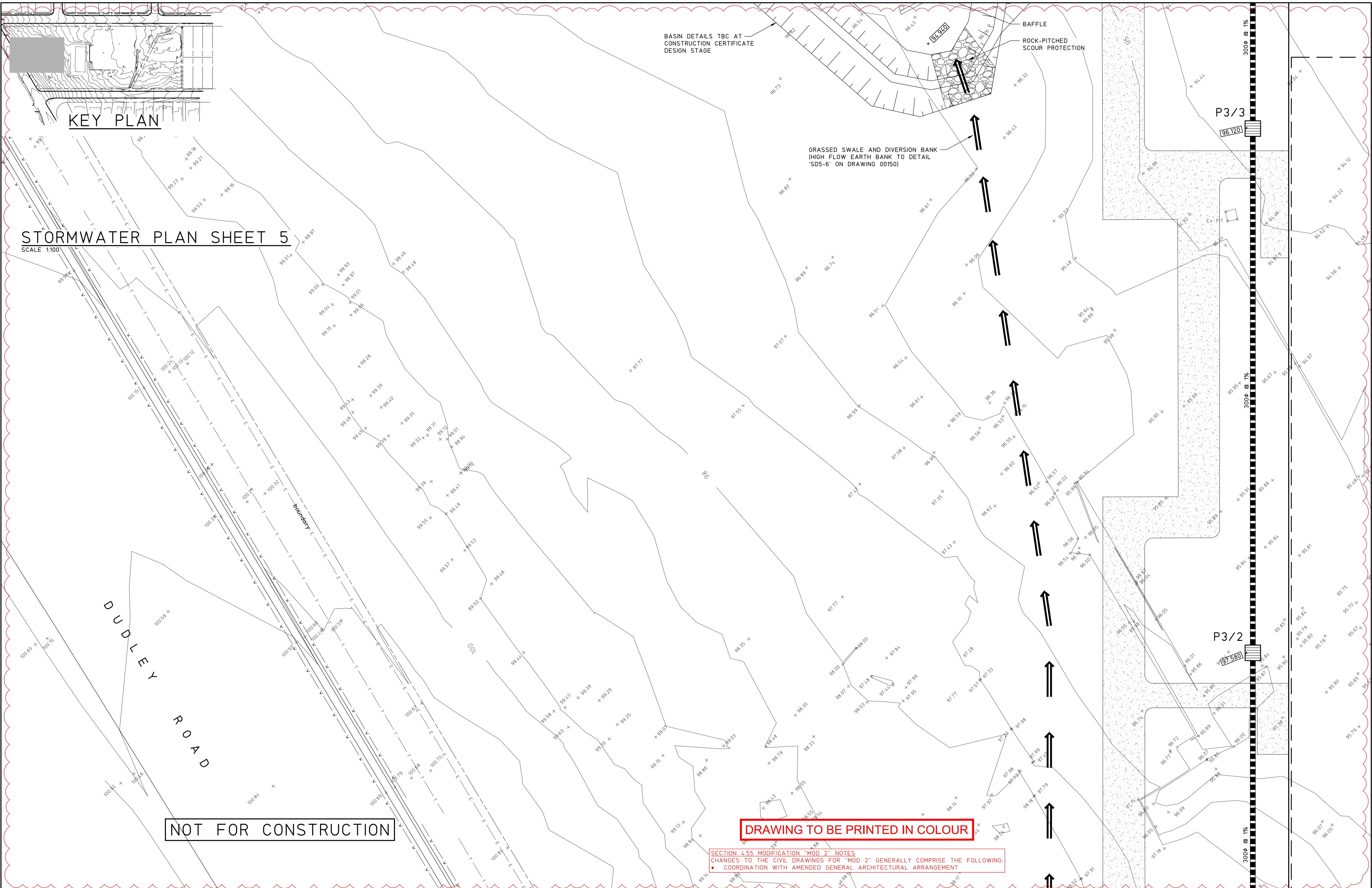

6	REVISED DEVELOPMENT APPLICATION - MOD 2	3.12.25
5	REVISED DEVELOPMENT APPLICATION - MOD 1	3.9.25
4	REVISED DEVELOPMENT APPLICATION	25.8.22
3	DEVELOPMENT APPLICATION	19.8.22
2	PRELIMINARY DEVELOPMENT APPLICATION	12.8.22
1	COORDINATION	1.7.22
0	80% DA - CLIENT REVIEW	19.11.21
ISSUE	REASON FOR ISSUE	DATE

© Copyright MPC Consulting Engineers as date of issue	
THIS DRAWING IS NOT TO BE USED FOR CONSTRUCTION UNLESS ENDORSED BELOW	
DATE OF RELEASE	RESPONSIBLE PRINCIPAL SIGNATURE

COPYRIGHT

The concepts and information contained in this document are the copyright of MPC Consulting Engineers. Use or copying of the document in whole or in part without the written permission of MPC Consulting Engineers constitutes an infringement of copyright.

mpc
consulting engineers
civil+structural

Level 1,
16 Telford Street,
NEWCASTLE EAST, NSW 2300
PO BOX 871
NEWCASTLE, NSW 2300
Tel: (02) 4927 5566
Email: admin@mpceng.com.au
Web: www.mpceng.com.au
A.C.N. 670 257 315

CLIENT
UNITING

TITLE
STORMWATER PLAN SHEET 5

PROJECT
**PROPOSED UNITING DEVELOPMENT AT;
LOT 223, DP 551260,
No.27 TIRAL STREET,
CHARLESTOWN**

DO NOT SCALE DRAWING			
DRAWN J.D.L.	ENGINEER B.C.	No in SET -	SHEET A1
SCALES 1:100	JOB No 200243	DRAWING No 00205	ISSUE 6

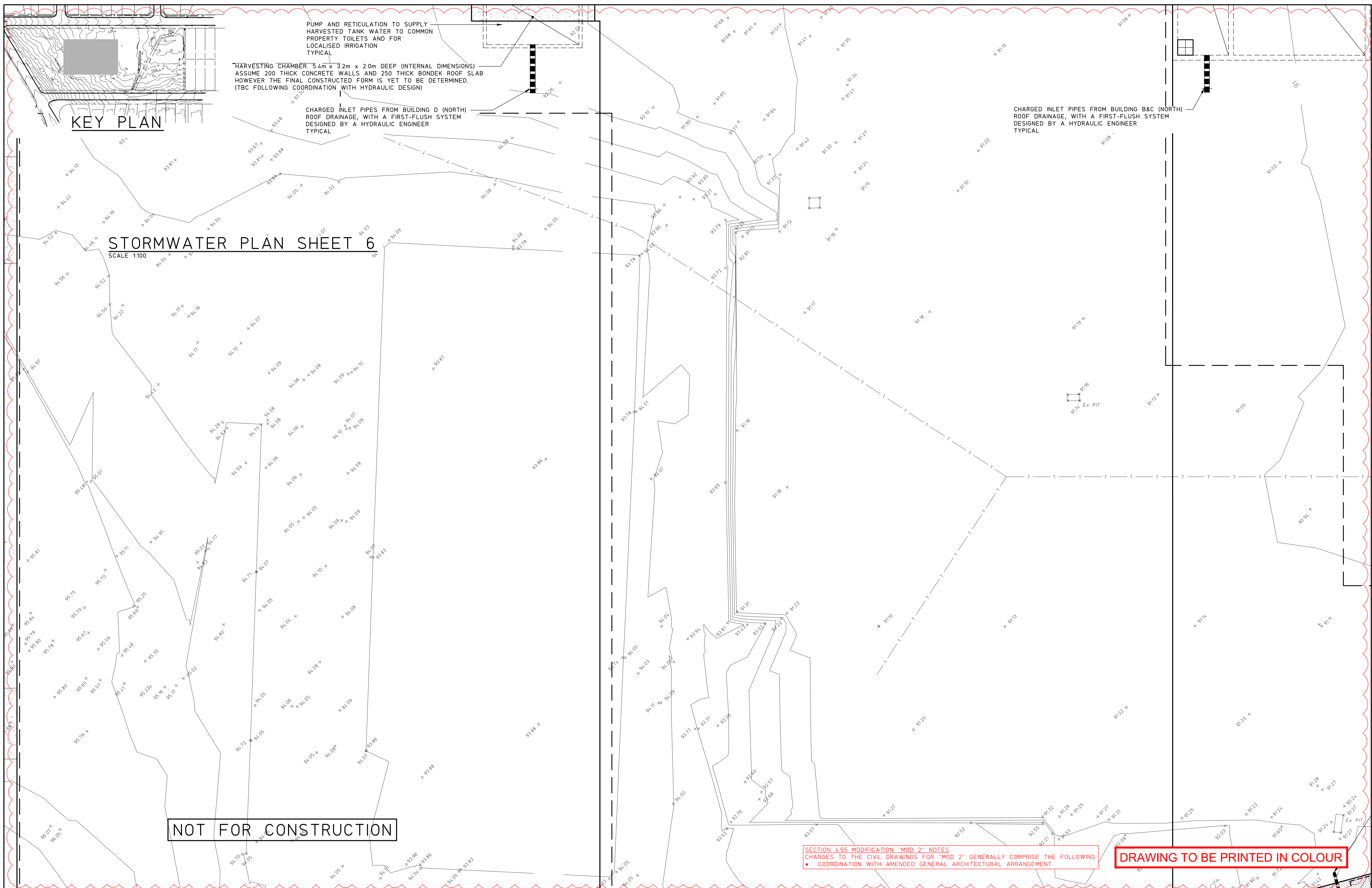

KEY PLAN

HARVESTING CHAMBER 5.4m x 3.2m x 2.0m DEEP (INTERNAL DIMENSIONS)
 ASSUME 200 THICK CONCRETE WALLS AND 250 THICK BONDEK ROOF SLAB
 HOWEVER THE FINAL CONSTRUCTED FORM IS YET TO BE DETERMINED.
 (TBC FOLLOWING COORDINATION WITH HYDRAULIC DESIGN)

CHARGED INLET PIPES FROM BUILDING D (NORTH)
 ROOF DRAINAGE, WITH A FIRST-FLUSH SYSTEM
 DESIGNED BY A HYDRAULIC ENGINEER
 TYPICAL

CHARGED INLET PIPES FROM BUILDING B&C (NORTH)
 ROOF DRAINAGE, WITH A FIRST-FLUSH SYSTEM
 DESIGNED BY A HYDRAULIC ENGINEER
 TYPICAL

STORMWATER PLAN SHEET 6

SCALE 1:100

NOT FOR CONSTRUCTION

SECTION 4.55 MODIFICATION "MOD 2" NOTES
 CHANGES TO THE CIVIL DRAWINGS FOR "MOD 2" GENERALLY COMPRISE THE FOLLOWING:
 • COORDINATION WITH AMENDED GENERAL ARCHITECTURAL ARRANGEMENT

DRAWING TO BE PRINTED IN COLOUR

7	REVISED DEVELOPMENT APPLICATION - MOD 2	3.12.25
6	REVISED DEVELOPMENT APPLICATION - MOD 1	1.10.25
5	REVISED DEVELOPMENT APPLICATION - MOD 1	3.9.25
4	REVISED DEVELOPMENT APPLICATION	25.8.22
3	DEVELOPMENT APPLICATION	19.8.22
2	PRELIMINARY DEVELOPMENT APPLICATION	12.8.22
1	COORDINATION	1.7.22
0	80% DA - CLIENT REVIEW	19.11.21

REASON FOR ISSUE	DATE	DATE OF RELEASE	RESPONSIBLE PRINCIPAL SIGNATURE	ISSUE
THIS DRAWING IS NOT TO BE USED FOR CONSTRUCTION UNLESS ENDORSED BELOW				

COPYRIGHT
 The concepts and information contained in this document are the copyright of MPC Consulting Engineers. Use or copying of the document in whole or in part without the written permission of MPC Consulting Engineers constitutes an infringement of copyright.

mpc consulting engineers civil+structural

Level 1,
 16 Telford Street,
 NEWCASTLE EAST, NSW 2300
 PO BOX 871
 NEWCASTLE, NSW 2300
 Tel: (02) 4927 5566
 Email: admin@mpceng.com.au
 Web: www.mpceng.com.au
 A.C.N. 670 257 315

CLIENT
UNITING

TITLE
STORMWATER PLAN SHEET 6

PROJECT
**PROPOSED UNITING DEVELOPMENT AT;
 LOT 223, DP 551260,
 No.27 TIRAL STREET,
 CHARLESTOWN**

DO NOT SCALE DRAWING			
DRAWN J.D.L.	ENGINEER B.C.	No in SET -	SHEET A1
SCALES 1:100	JOB No 200243	DRAWING No 00206	ISSUE 7

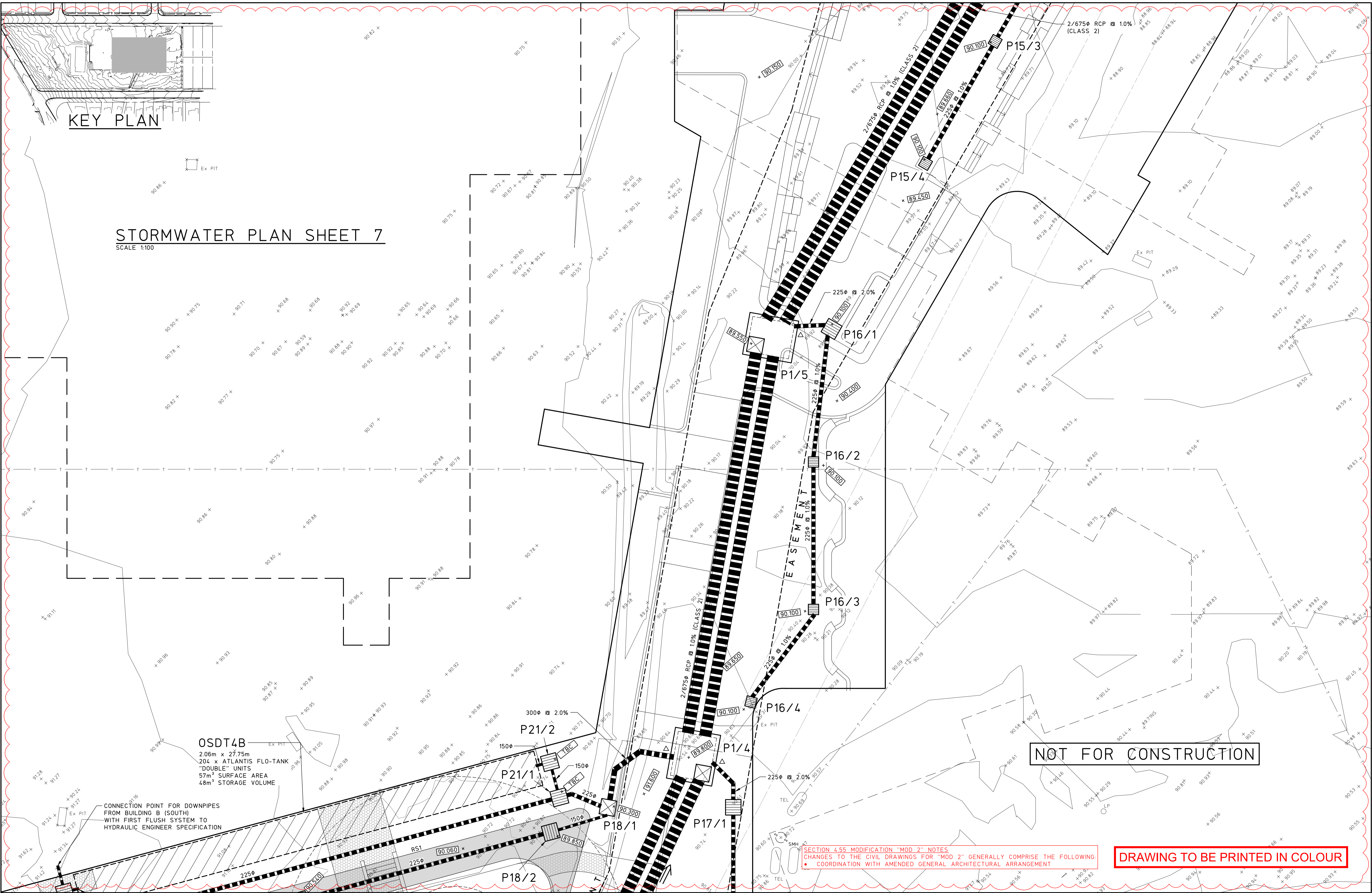

STORMWATER PLAN SHEET 7
SCALE 1:100

OSDT4B
2.06m x 27.75m
204 x ATLANTIS FLO-TANK
"DOUBLE" UNITS
57m² SURFACE AREA
48m³ STORAGE VOLUME

CONNECTION POINT FOR DOWNPIPES
FROM BUILDING B (SOUTH)
WITH FIRST FLUSH SYSTEM TO
HYDRAULIC ENGINEER SPECIFICATION

NOT FOR CONSTRUCTION

SECTION 4.55 MODIFICATION "MOD 2" NOTES
CHANGES TO THE CIVIL DRAWINGS FOR "MOD 2" GENERALLY COMPRISE THE FOLLOWING:
• COORDINATION WITH AMENDED GENERAL ARCHITECTURAL ARRANGEMENT

DRAWING TO BE PRINTED IN COLOUR

6	REVISED DEVELOPMENT APPLICATION - MOD 2	3.12.25
5	REVISED DEVELOPMENT APPLICATION - MOD 1	3.9.25
4	REVISED DEVELOPMENT APPLICATION	25.8.22
3	DEVELOPMENT APPLICATION	19.8.22
2	PRELIMINARY DEVELOPMENT APPLICATION	12.8.22
1	COORDINATION	1.7.22
0	80% DA - CLIENT REVIEW	19.11.21

© Copyright MPC Consulting Engineers as date of issue	
THIS DRAWING IS NOT TO BE USED FOR CONSTRUCTION UNLESS ENDORSED BELOW	
DATE	RESPONSIBLE PRINCIPAL SIGNATURE

COPYRIGHT
The concepts and information contained in this document are the copyright of MPC Consulting Engineers. Use or copying of the document in whole or in part without the written permission of MPC Consulting Engineers constitutes an infringement of copyright.

mpc
consulting engineers
civil+structural

Level 1,
16 Telford Street,
NEWCASTLE EAST, NSW 2300
PO BOX 871
NEWCASTLE, NSW 2300
Tel: (02) 4927 5566
Email: admin@mpceng.com.au
Web: www.mpceng.com.au
A.C.N. 670 257 315

CLIENT
UNITING

TITLE
STORMWATER PLAN SHEET 7

PROJECT
**PROPOSED UNITING DEVELOPMENT AT;
LOT 223, DP 551260,
No.27 TIRAL STREET,
CHARLESTOWN**

DO NOT SCALE DRAWING			
DRAWN J.D.L.	ENGINEER B.C.	No in SET -	SHEET A1
SCALES 1:100	JOB No 200243	DRAWING No 00207	ISSUE 6

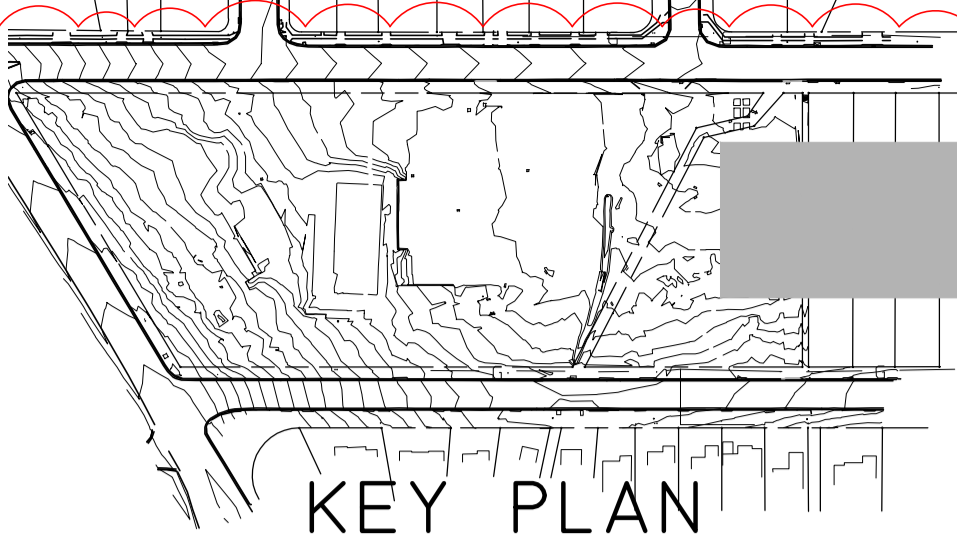
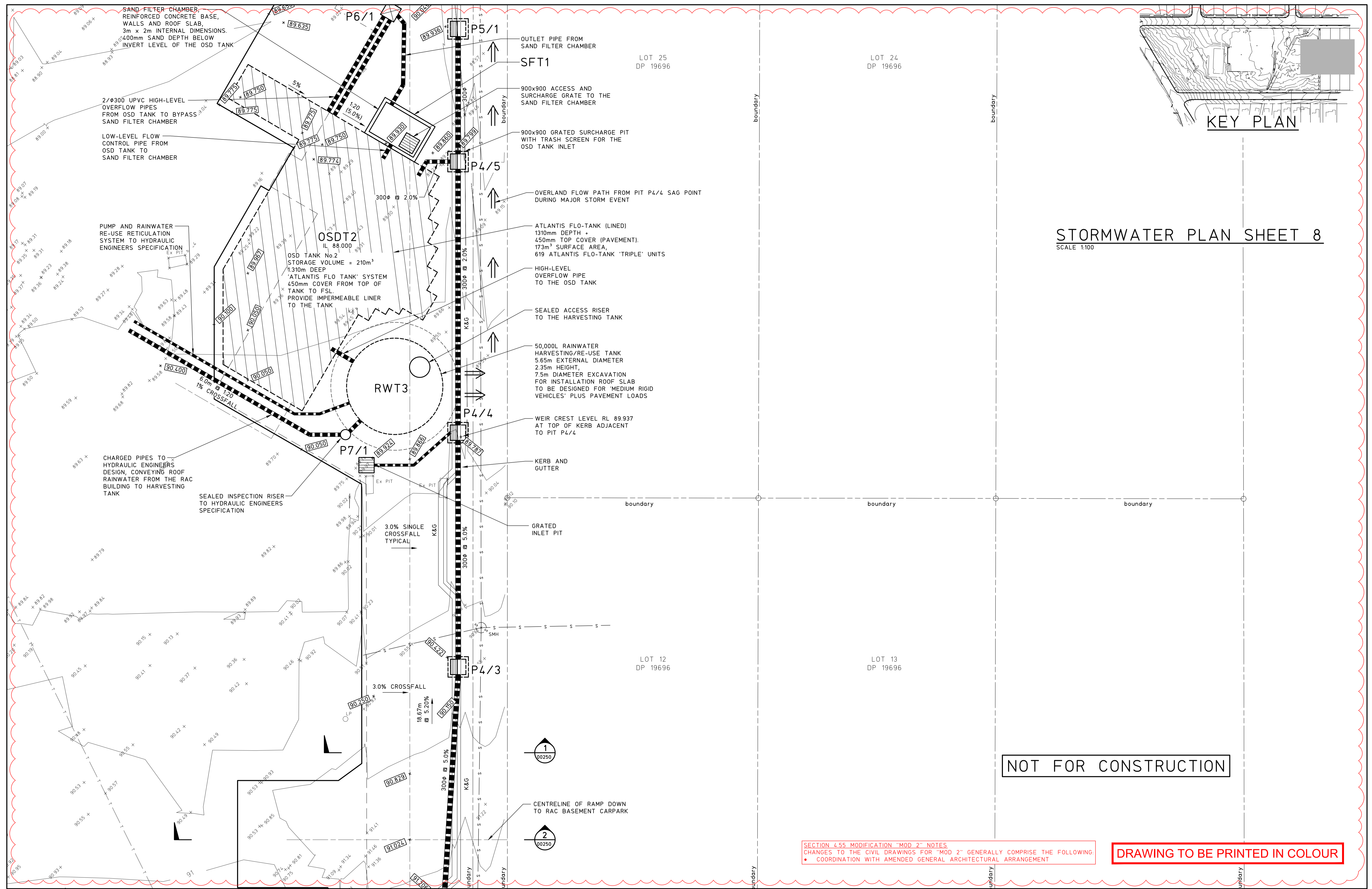

STORMWATER PLAN SHEET 8
SCALE 1:100

NOT FOR CONSTRUCTION

DRAWING TO BE PRINTED IN COLOUR

SECTION 4.55 MODIFICATION "MOD 2" NOTES
CHANGES TO THE CIVIL DRAWINGS FOR "MOD 2" GENERALLY COMPRISE THE FOLLOWING:
• COORDINATION WITH AMENDED GENERAL ARCHITECTURAL ARRANGEMENT

6	REVISED DEVELOPMENT APPLICATION - MOD 2	3.12.25
5	REVISED DEVELOPMENT APPLICATION - MOD 1	3.9.25
4	REVISED DEVELOPMENT APPLICATION	25.8.22
3	DEVELOPMENT APPLICATION	19.8.22
2	PRELIMINARY DEVELOPMENT APPLICATION	12.8.22
1	COORDINATION	1.7.22
0	80% DA - CLIENT REVIEW	19.11.21
ISSUE	REASON FOR ISSUE	DATE

© Copyright MPC Consulting Engineers as date of issue

THIS DRAWING IS NOT TO BE USED FOR CONSTRUCTION UNLESS ENDORSED BELOW

COPYRIGHT

The concepts and information contained in this document are the copyright of MPC Consulting Engineers. Use or copying of the document in whole or in part without the written permission of MPC Consulting Engineers constitutes an infringement of copyright.

Level 1,
16 Telford Street,
NEWCASTLE EAST, NSW 2300
PO BOX 871
NEWCASTLE, NSW 2300
Tel: (02) 4927 5566
Email: admin@mpceng.com.au
Web: www.mpceng.com.au
A.C.N. 670 257 315

CLIENT
UNITING

TITLE
STORMWATER PLAN SHEET 8

PROJECT
**PROPOSED UNITING DEVELOPMENT AT;
LOT 223, DP 551260,
No.27 TIRAL STREET,
CHARLESTOWN**

DO NOT SCALE DRAWING			
DRAWN J.D.L.	ENGINEER B.C.	No in SET -	SHEET A1
SCALES 1:100	JOB No 200243	DRAWING No 00208	ISSUE 6

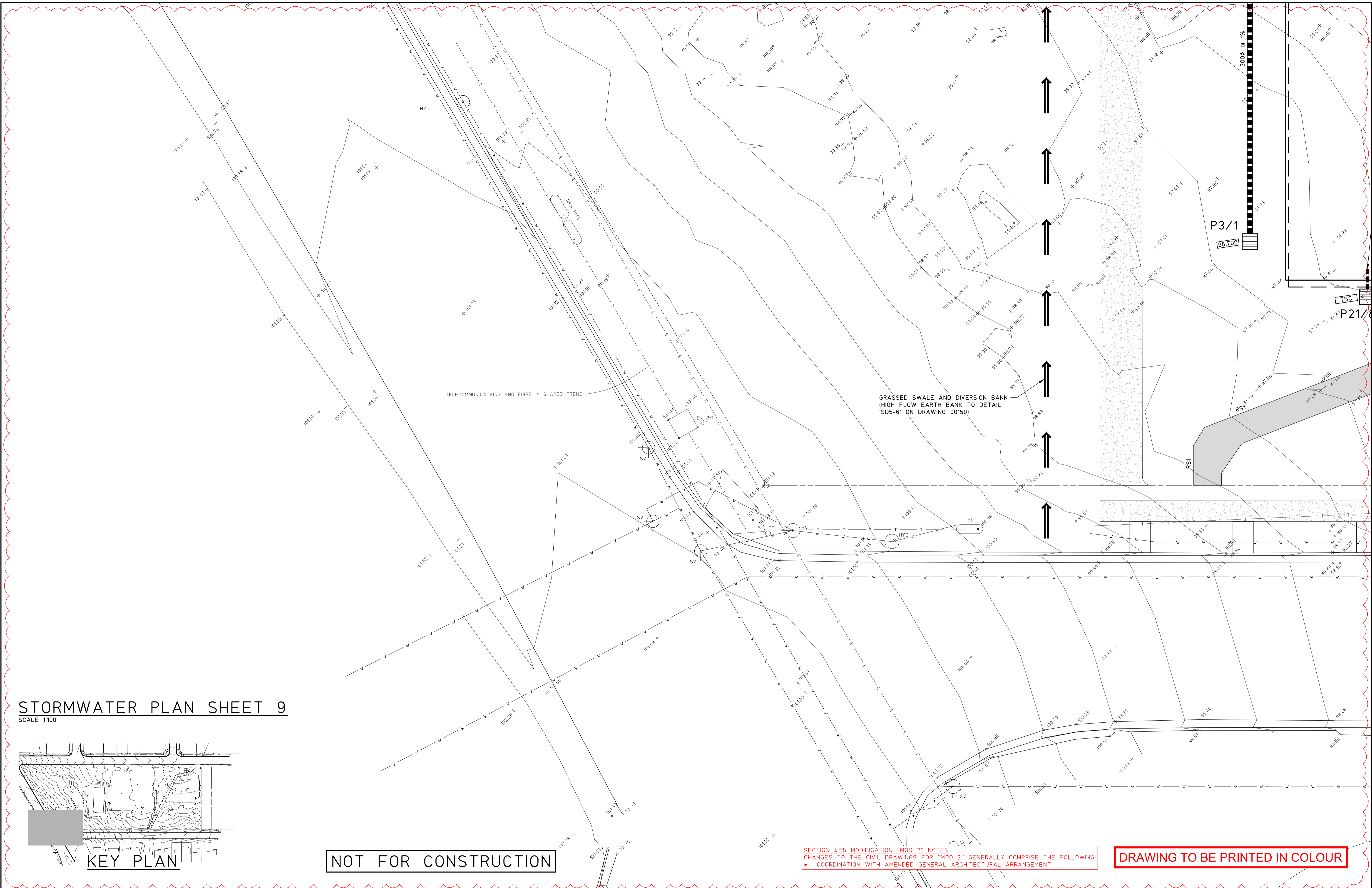

STORMWATER PLAN SHEET 9
SCALE 1:100

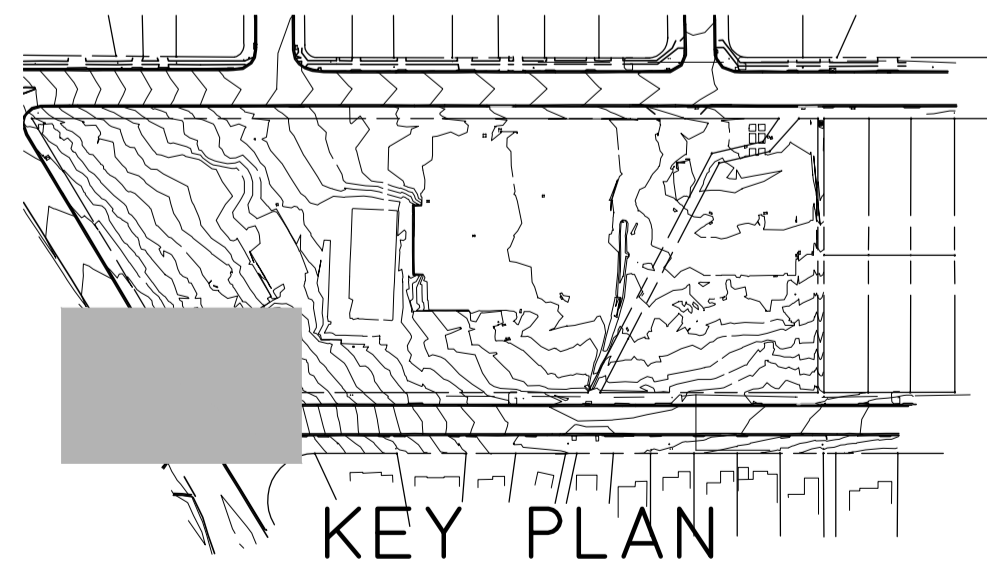

KEY PLAN

NOT FOR CONSTRUCTION

SECTION 4.55 MODIFICATION "MOD 2" NOTES
CHANGES TO THE CIVIL DRAWINGS FOR "MOD 2" GENERALLY COMPRISE THE FOLLOWING:
• COORDINATION WITH AMENDED GENERAL ARCHITECTURAL ARRANGEMENT

DRAWING TO BE PRINTED IN COLOUR

6	REVISED DEVELOPMENT APPLICATION - MOD 2	3.12.25
5	REVISED DEVELOPMENT APPLICATION - MOD 1	3.9.25
4	REVISED DEVELOPMENT APPLICATION	25.8.22
3	DEVELOPMENT APPLICATION	19.8.22
2	PRELIMINARY DEVELOPMENT APPLICATION	12.8.22
1	COORDINATION	1.7.22
0	80% DA - CLIENT REVIEW	19.11.21

© Copyright MPC Consulting Engineers as date of issue	
THIS DRAWING IS NOT TO BE USED FOR CONSTRUCTION UNLESS ENDORSED BELOW	
DATE	REASON FOR ISSUE
DATE OF RELEASE	RESPONSIBLE PRINCIPAL SIGNATURE
ISSUE	ISSUE

COPYRIGHT
The concepts and information contained in this document are the copyright of MPC Consulting Engineers. Use or copying of the document in whole or in part without the written permission of MPC Consulting Engineers constitutes an infringement of copyright.

mpc consulting engineers civil+structural
Level 1, 16 Telford Street, NEWCASTLE EAST, NSW 2300
PO BOX 871 NEWCASTLE, NSW 2300
Tel: (02) 4927 5566
Email: admin@mpceng.com.au
Web: www.mpceng.com.au
A.C.N. 670 257 315

CLIENT
UNITING
TITLE
STORMWATER PLAN SHEET 9

PROJECT
PROPOSED UNITING DEVELOPMENT AT;
LOT 223, DP 551260,
No.27 TIRAL STREET,
CHARLESTOWN

DO NOT SCALE DRAWING			
DRAWN J.D.L.	ENGINEER B.C.	No in SET -	SHEET A1
SCALES 1:100	JOB No 200243	DRAWING No 00209	ISSUE 6

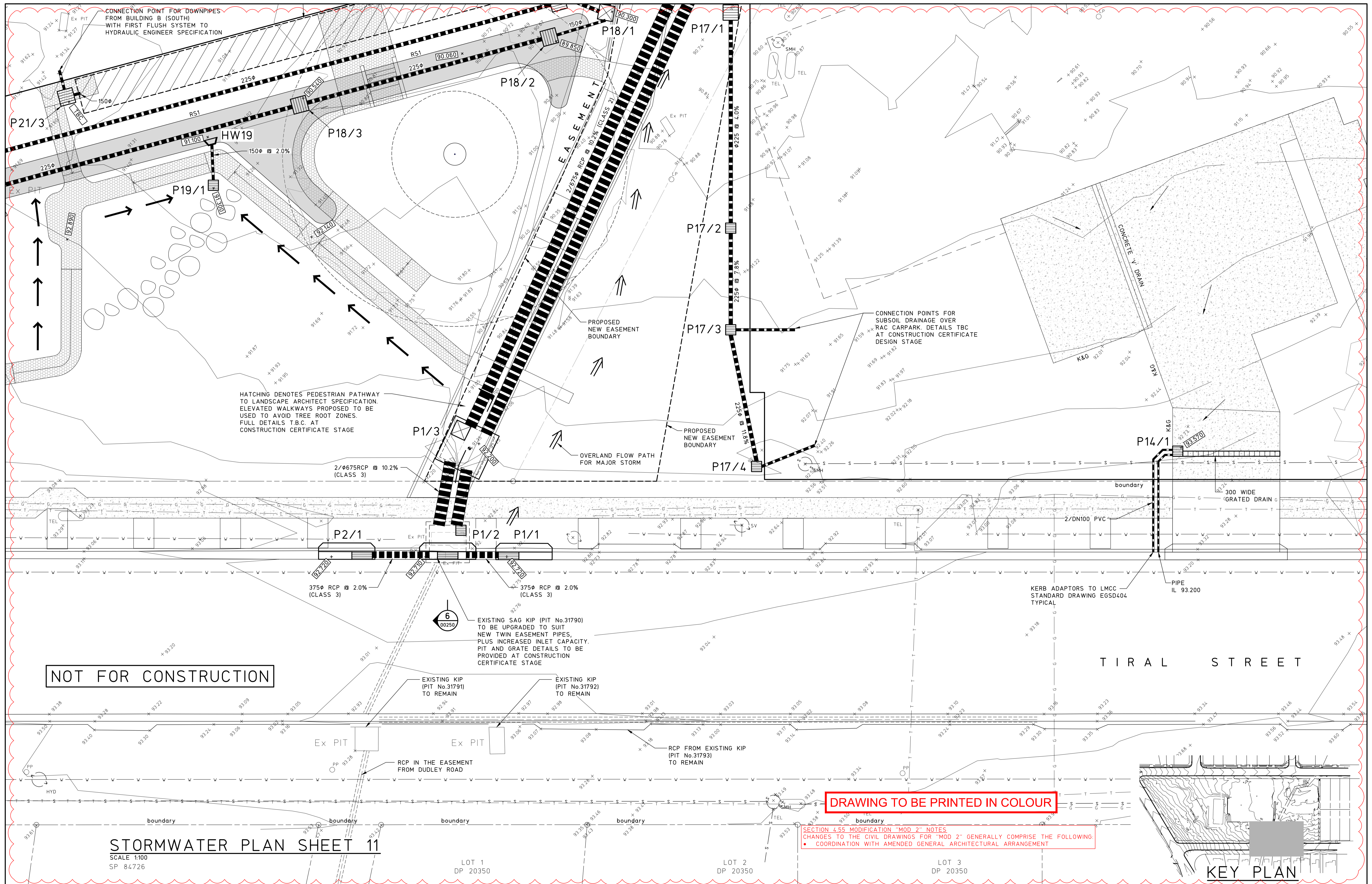

NOT FOR CONSTRUCTION

DRAWING TO BE PRINTED IN COLOUR

STORMWATER PLAN SHEET 11

SCALE 1:100
SP 8.4.726

LOT 1
DP 20350

LOT 2
DP 20350

LOT 3
DP 20350

SECTION 4.55 MODIFICATION "MOD 2" NOTES
CHANGES TO THE CIVIL DRAWINGS FOR "MOD 2" GENERALLY COMPRISE THE FOLLOWING:
• COORDINATION WITH AMENDED GENERAL ARCHITECTURAL ARRANGEMENT

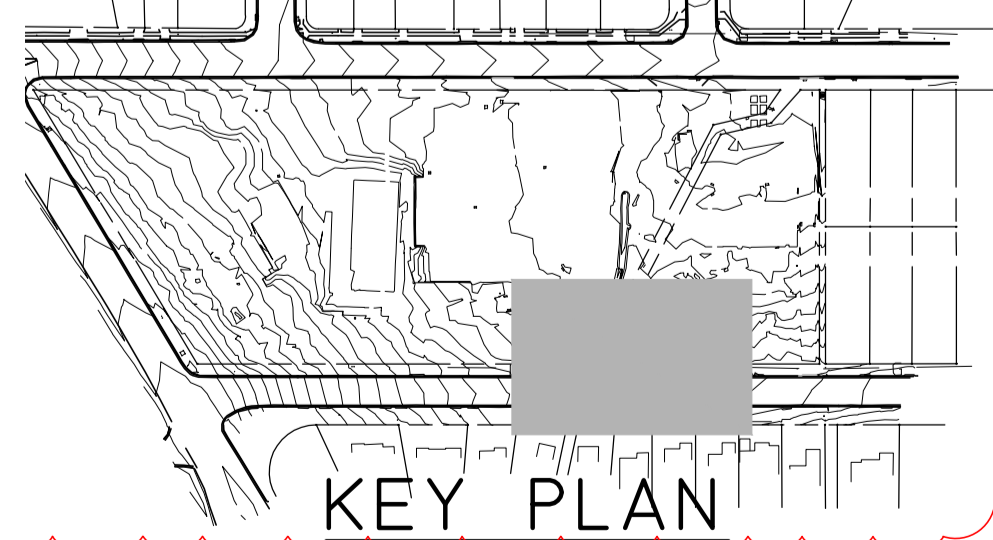

6	REVISED DEVELOPMENT APPLICATION - MOD 2	3.12.25
5	REVISED DEVELOPMENT APPLICATION - MOD 1	3.9.25
4	REVISED DEVELOPMENT APPLICATION	25.8.22
3	DEVELOPMENT APPLICATION	19.8.22
2	PRELIMINARY DEVELOPMENT APPLICATION	12.8.22
1	COORDINATION	1.7.22
0	80% DA - CLIENT REVIEW	19.11.21
ISSUE	REASON FOR ISSUE	DATE

© Copyright MPC Consulting Engineers as date of issue	
THIS DRAWING IS NOT TO BE USED FOR CONSTRUCTION UNLESS ENDORSED BELOW	
DATE OF RELEASE	RESPONSIBLE PRINCIPAL SIGNATURE

COPYRIGHT
The concepts and information contained in this document are the copyright of MPC Consulting Engineers. Use or copying of the document in whole or in part without the written permission of MPC Consulting Engineers constitutes an infringement of copyright.

Level 1,
16 Telford Street,
NEWCASTLE EAST, NSW 2300
PO BOX 871
NEWCASTLE, NSW 2300
Tel: (02) 4927 5566
Email: admin@mpceng.com.au
Web: www.mpceng.com.au
A.C.N. 670 257 315

CLIENT
UNITING

TITLE
STORMWATER PLAN SHEET 11

PROJECT
**PROPOSED UNITING DEVELOPMENT AT;
LOT 223, DP 551260,
No.27 TIRAL STREET,
CHARLESTOWN**

DO NOT SCALE DRAWING			
DRAWN J.D.L.	ENGINEER B.C.	No in SET -	SHEET A1
SCALES 1:100	JOB No 200243	DRAWING No 00211	ISSUE 6

FULL SIZE ON ORIGINAL 0 1 2 3 4 5 6 7 8 9 10 11 12 13 14 15 cm

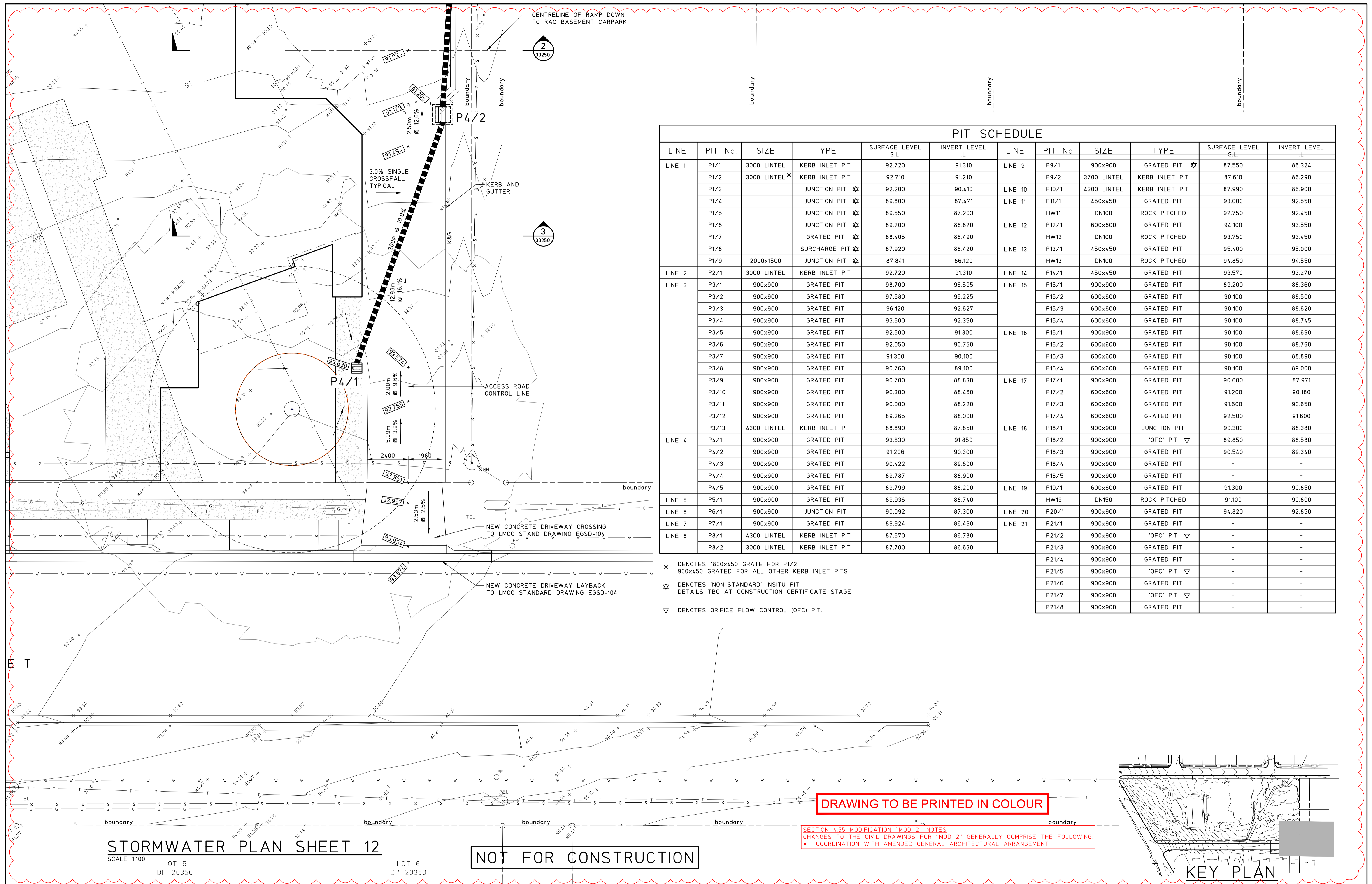

PIT SCHEDULE

LINE	PIT No.	SIZE	TYPE	SURFACE LEVEL S.L.	INVERT LEVEL I.L.	LINE	PIT No.	SIZE	TYPE	SURFACE LEVEL S.L.	INVERT LEVEL I.L.
LINE 1	P1/1	3000 LINTEL	KERB INLET PIT	92.720	91.310	LINE 9	P9/1	900x900	GRATED PIT ✱	87.550	86.324
	P1/2	3000 LINTEL *	KERB INLET PIT	92.710	91.210		P9/2	3700 LINTEL	KERB INLET PIT	87.610	86.290
	P1/3		JUNCTION PIT ✱	92.200	90.410	LINE 10	P10/1	4300 LINTEL	KERB INLET PIT	87.990	86.900
	P1/4		JUNCTION PIT ✱	89.800	87.471		LINE 11	P11/1	450x450	GRATED PIT	93.000
	P1/5		JUNCTION PIT ✱	89.550	87.203	LINE 12	HW11	DN100	ROCK PITCHED	92.750	92.450
	P1/6		JUNCTION PIT ✱	89.200	86.820		P12/1	600x600	GRATED PIT	94.100	93.550
	P1/7		GRATED PIT ✱	88.405	86.490	LINE 13	HW12	DN100	ROCK PITCHED	93.750	93.450
	P1/8		SURCHARGE PIT ✱	87.920	86.420		P13/1	450x450	GRATED PIT	95.400	95.000
	P1/9	2000x1500	JUNCTION PIT ✱	87.841	86.120	LINE 14	HW13	DN100	ROCK PITCHED	94.850	94.550
LINE 2	P2/1	3000 LINTEL	KERB INLET PIT	92.720	91.310		P14/1	450x450	GRATED PIT	93.570	93.270
	LINE 3	P3/1	900x900	GRATED PIT	98.700	96.595	LINE 15	P15/1	900x900	GRATED PIT	89.200
P3/2		900x900	GRATED PIT	97.580	95.225	P15/2		600x600	GRATED PIT	90.100	88.500
P3/3		900x900	GRATED PIT	96.120	92.627	P15/3		600x600	GRATED PIT	90.100	88.620
P3/4		900x900	GRATED PIT	93.600	92.350	P15/4		600x600	GRATED PIT	90.100	88.745
P3/5		900x900	GRATED PIT	92.500	91.300	LINE 16	P16/1	900x900	GRATED PIT	90.100	88.690
P3/6		900x900	GRATED PIT	92.050	90.750		P16/2	600x600	GRATED PIT	90.100	88.760
P3/7		900x900	GRATED PIT	91.300	90.100		P16/3	600x600	GRATED PIT	90.100	88.890
P3/8		900x900	GRATED PIT	90.760	89.100		P16/4	600x600	GRATED PIT	90.100	89.000
P3/9		900x900	GRATED PIT	90.700	88.830	LINE 17	P17/1	900x900	GRATED PIT	90.600	87.971
P3/10		900x900	GRATED PIT	90.300	88.460		P17/2	600x600	GRATED PIT	91.200	90.180
P3/11		900x900	GRATED PIT	90.000	88.220		P17/3	600x600	GRATED PIT	91.600	90.650
P3/12		900x900	GRATED PIT	89.265	88.000		P17/4	600x600	GRATED PIT	92.500	91.600
LINE 4		P4/1	900x900	GRATED PIT	93.630	91.850	LINE 18	P18/1	900x900	JUNCTION PIT	90.300
	P4/2	900x900	GRATED PIT	91.206	90.300	P18/2		900x900	'OFC' PIT ▽	89.850	88.580
	P4/3	900x900	GRATED PIT	90.422	89.600	P18/3		900x900	GRATED PIT	90.540	89.340
	P4/4	900x900	GRATED PIT	89.787	88.900	P18/4		900x900	GRATED PIT	-	-
	P4/5	900x900	GRATED PIT	89.799	88.200	P18/5		900x900	GRATED PIT	-	-
LINE 5	P5/1	900x900	GRATED PIT	89.936	88.740	LINE 19	P19/1	600x600	GRATED PIT	91.300	90.850
	LINE 6	P6/1	900x900	JUNCTION PIT	90.092		87.300	LINE 20	P20/1	900x900	GRATED PIT
LINE 7		P7/1	900x900	GRATED PIT	89.924	86.490	LINE 21	P21/1	900x900	GRATED PIT	-
	LINE 8	P8/1	4300 LINTEL	KERB INLET PIT	87.670	86.780		P21/2	900x900	'OFC' PIT ▽	-
P8/2		3000 LINTEL	KERB INLET PIT	87.700	86.630	P21/3		900x900	GRATED PIT	-	-
					P21/4	900x900		GRATED PIT	-	-	
					P21/5	900x900		'OFC' PIT ▽	-	-	
					P21/6	900x900		GRATED PIT	-	-	
					P21/7	900x900		'OFC' PIT ▽	-	-	
					P21/8	900x900		GRATED PIT	-	-	

* DENOTES 1800x450 GRATE FOR P1/2, 900x450 GRATED FOR ALL OTHER KERB INLET PITS
 ✱ DENOTES 'NON-STANDARD' INSITU PIT. DETAILS TBC AT CONSTRUCTION CERTIFICATE STAGE
 ▽ DENOTES ORIFICE FLOW CONTROL (OFC) PIT.

STORMWATER PLAN SHEET 12

SCALE 1:100

LOT 5
DP 20350

LOT 6
DP 20350

NOT FOR CONSTRUCTION

DRAWING TO BE PRINTED IN COLOUR

SECTION 4.55 MODIFICATION "MOD 2" NOTES
 CHANGES TO THE CIVIL DRAWINGS FOR "MOD 2" GENERALLY COMPRISE THE FOLLOWING:
 • COORDINATION WITH AMENDED GENERAL ARCHITECTURAL ARRANGEMENT

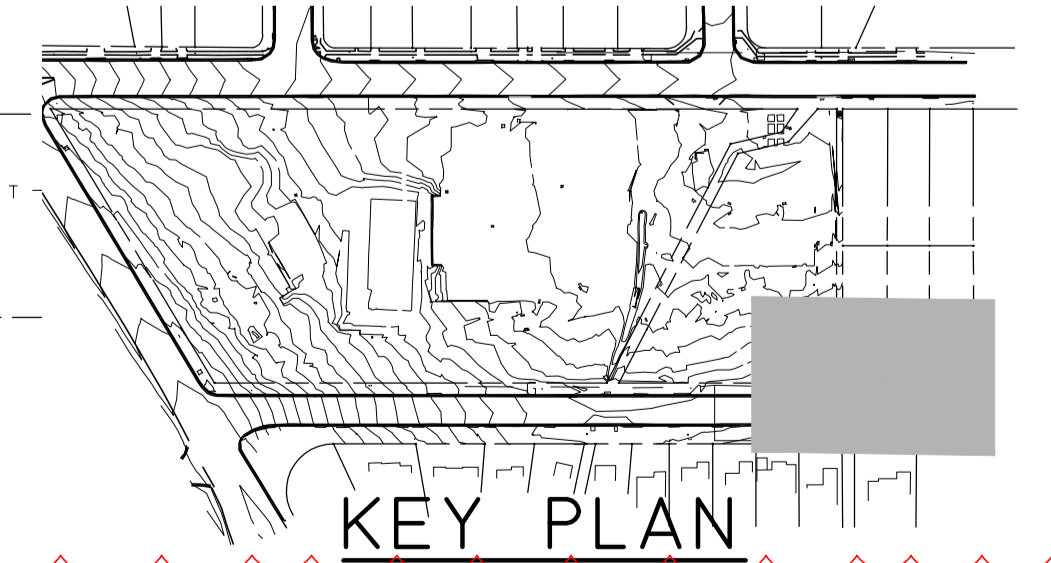

6 REVISED DEVELOPMENT APPLICATION - MOD 2 5 REVISED DEVELOPMENT APPLICATION - MOD 1 4 REVISED DEVELOPMENT APPLICATION 3 DEVELOPMENT APPLICATION 2 PRELIMINARY DEVELOPMENT APPLICATION 1 COORDINATION 0 80% DA - CLIENT REVIEW	3.12.25 3.9.25 25.8.22 19.8.22 12.8.22 1.7.22 19.11.21	© Copyright MPC Consulting Engineers as date of issue THIS DRAWING IS NOT TO BE USED FOR CONSTRUCTION UNLESS ENDORSED BELOW	COPYRIGHT The concepts and information contained in this document are the copyright of MPC Consulting Engineers. Use or copying of the document in whole or in part without the written permission of MPC Consulting Engineers constitutes an infringement of copyright.		CLIENT UNITING TITLE STORMWATER PLAN SHEET 12	PROJECT PROPOSED UNITING DEVELOPMENT AT; LOT 223, DP 551260, No.27 TIRAL STREET, CHARLESTOWN	DO NOT SCALE DRAWING DRAWN J.D.L. ENGINEER B.C. SCALES 1:100 JOB No 200243 DRAWING No 00212 ISSUE 6
---	--	---	---	--	--	---	--

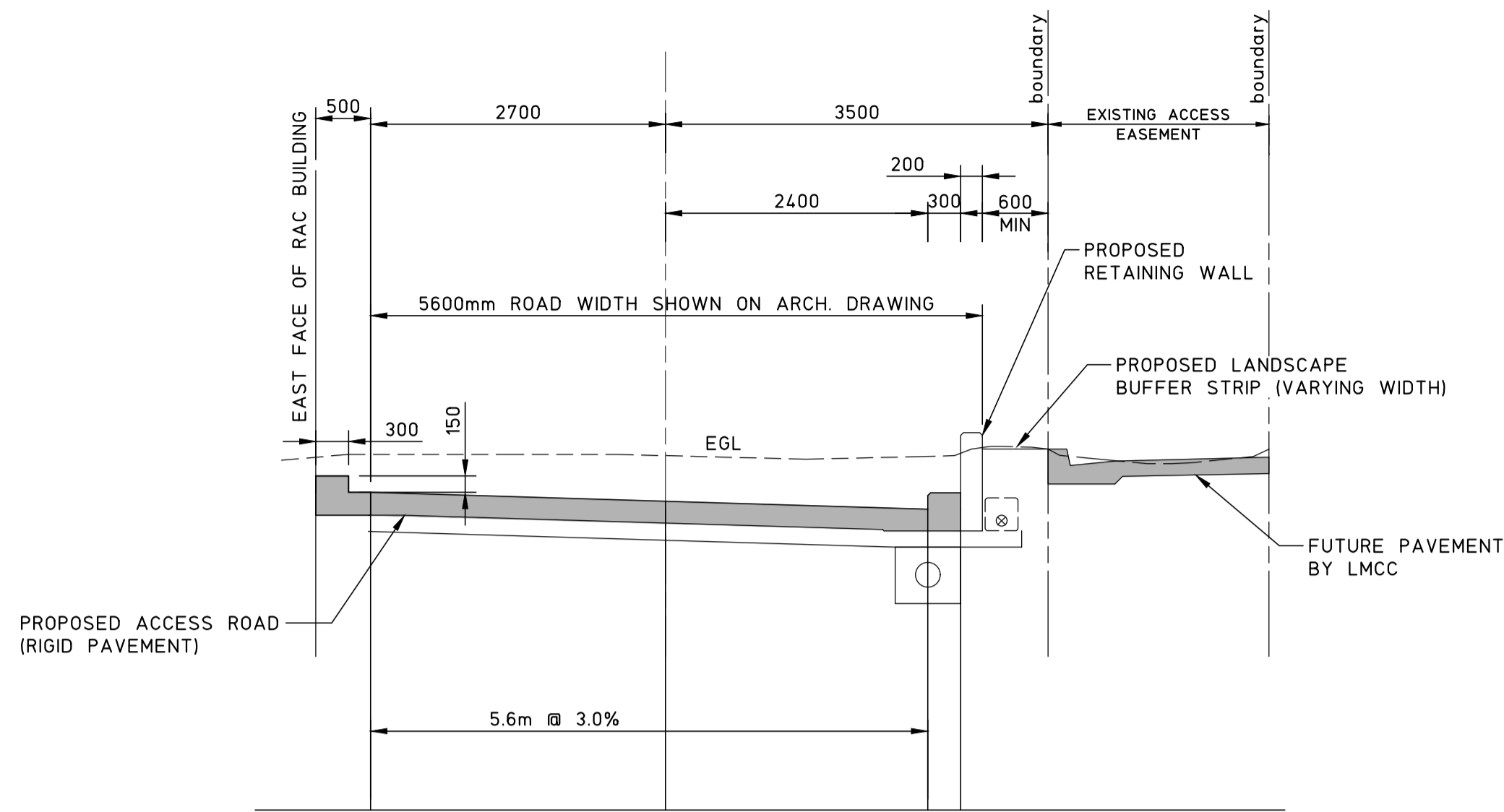

SECTION 1
SCALE 1:50
00207

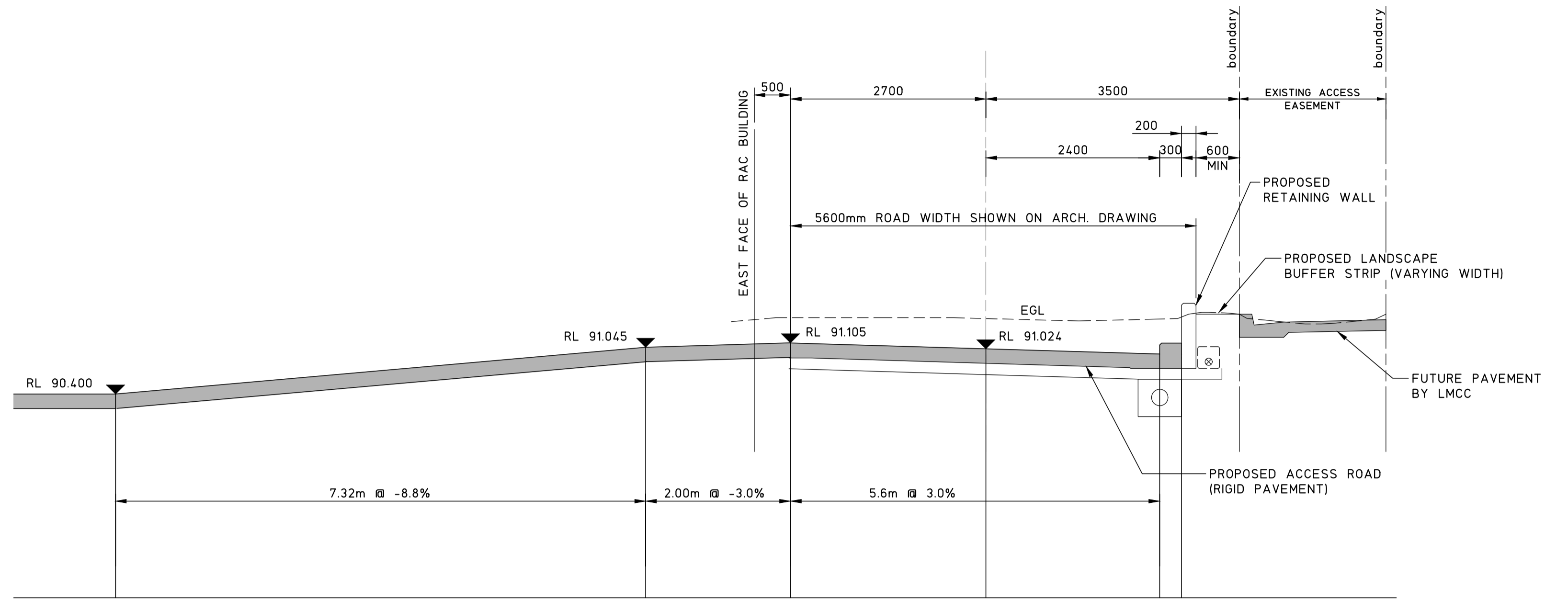

SECTION 2
SCALE 1:50
00207

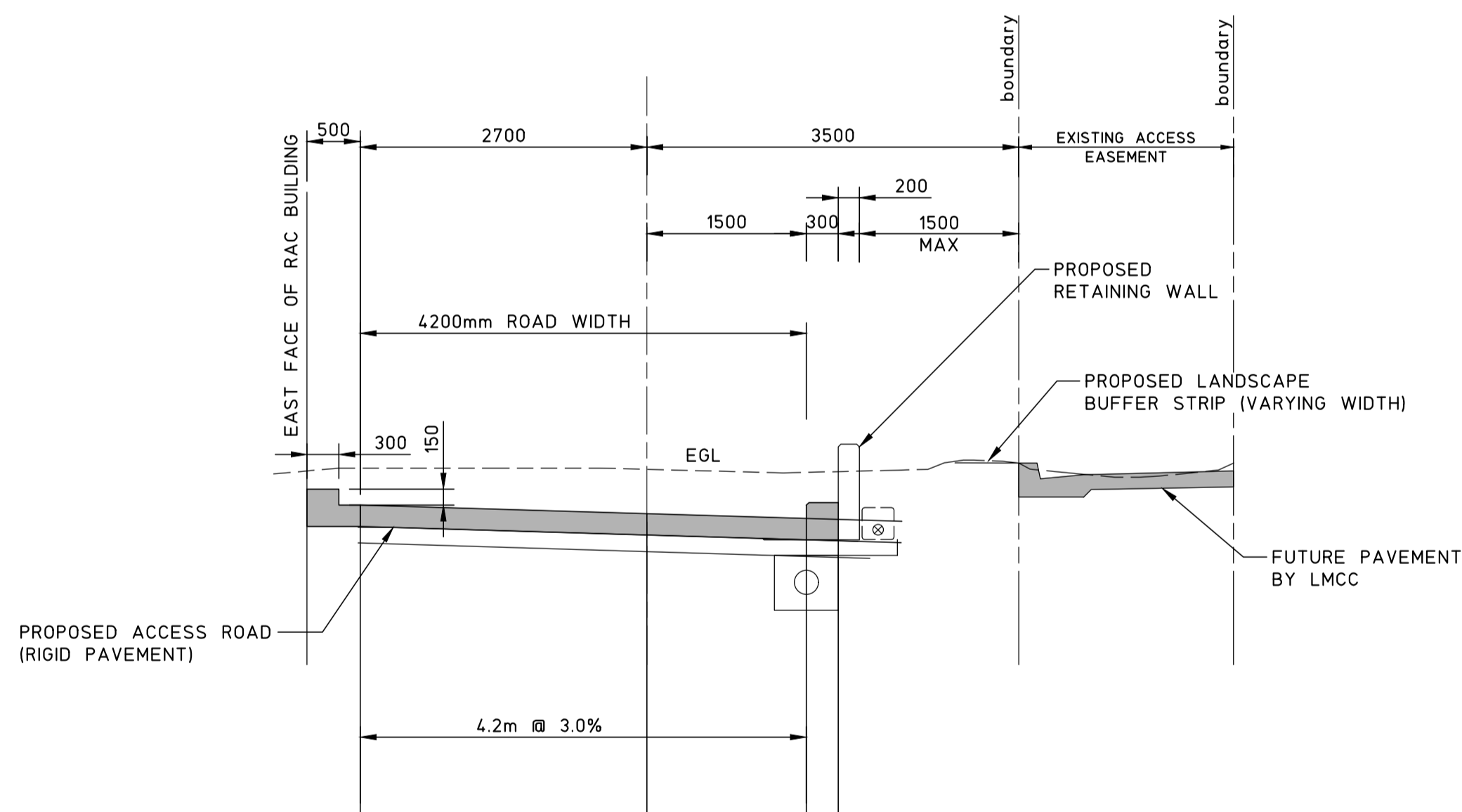

SECTION 3
SCALE 1:50
00211

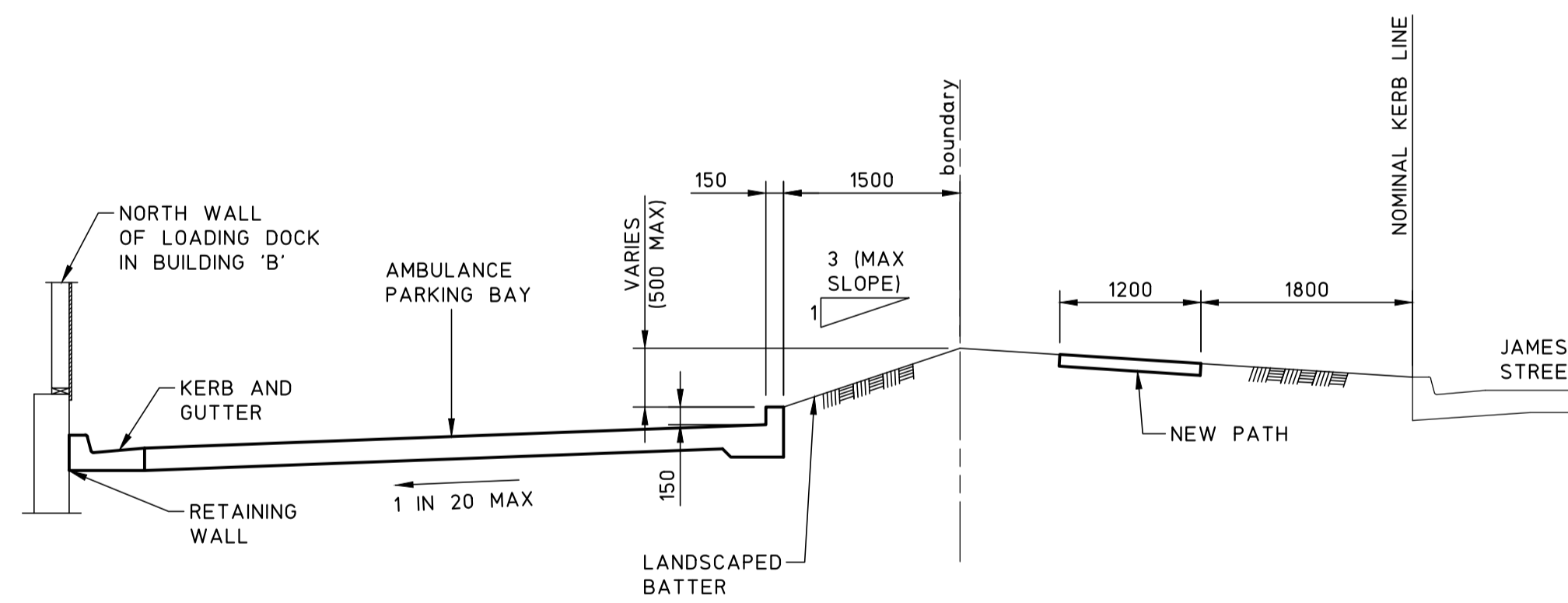

SECTION 4
SCALE 1:50
00203

NOT FOR CONSTRUCTION

SECTION 4.55 MODIFICATION "MOD 2" NOTES
CHANGES TO THE CIVIL DRAWINGS FOR "MOD 2" GENERALLY COMPRISE THE FOLLOWING:
• COORDINATION WITH AMENDED GENERAL ARCHITECTURAL ARRANGEMENT

DRAWING TO BE PRINTED IN COLOUR

6	REVISED DEVELOPMENT APPLICATION - MOD 2	3.12.25
5	REVISED DEVELOPMENT APPLICATION - MOD 1	3.9.25
4	REVISED DEVELOPMENT APPLICATION	25.8.22
3	DEVELOPMENT APPLICATION	19.8.22
2	PRELIMINARY DEVELOPMENT APPLICATION	12.8.22
1	COORDINATION	1.7.22
0	80% DA - CLIENT REVIEW	19.11.21

© Copyright MPC Consulting Engineers as date of issue		
THIS DRAWING IS NOT TO BE USED FOR CONSTRUCTION UNLESS ENDORSED BELOW		
ISSUE	REASON FOR ISSUE	DATE

COPYRIGHT
The concepts and information contained in this document are the copyright of MPC Consulting Engineers. Use or copying of the document in whole or in part without the written permission of MPC Consulting Engineers constitutes an infringement of copyright.

mpc consulting engineers
civil+structural

Level 1,
16 Telford Street,
NEWCASTLE EAST, NSW 2300
PO BOX 871
NEWCASTLE, NSW 2300
Tel: (02) 4927 5566
Email: admin@mpceng.com.au
Web: www.mpceng.com.au
A.C.N. 670 257 315

CLIENT
UNITING

TITLE
**STORMWATER SECTIONS
SHEET 1**

PROJECT
**PROPOSED UNITING DEVELOPMENT AT;
LOT 223, DP 551260,
No.27 TIRAL STREET,
CHARLESTOWN**

DO NOT SCALE DRAWING			
DRAWN J.D.L.	ENGINEER B.C.	No in SET -	SHEET A1
SCALES 1:50	JOB No 200243	DRAWING No 00250	ISSUE 6

FULL SIZE ON ORIGINAL 0 1 2 3 4 5 6 7 8 9 10 11 12 13 14 15 cm

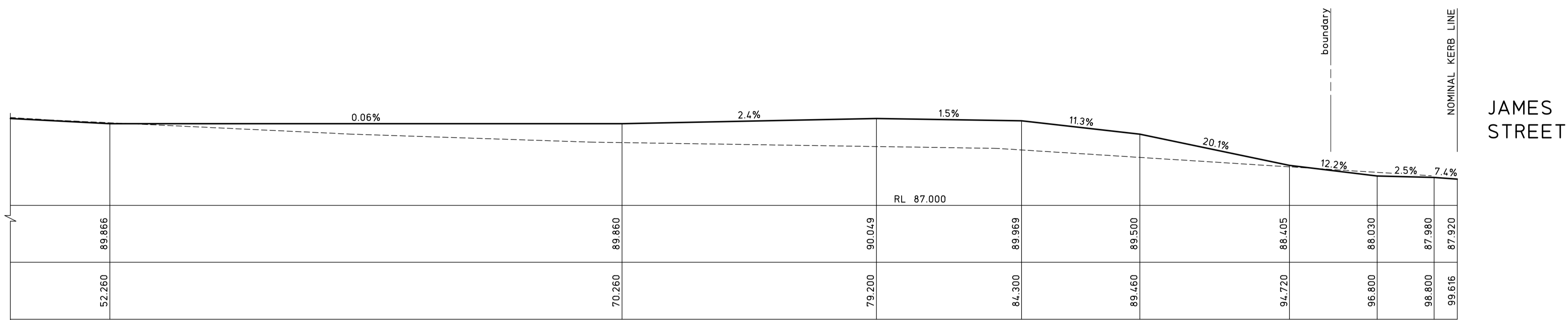
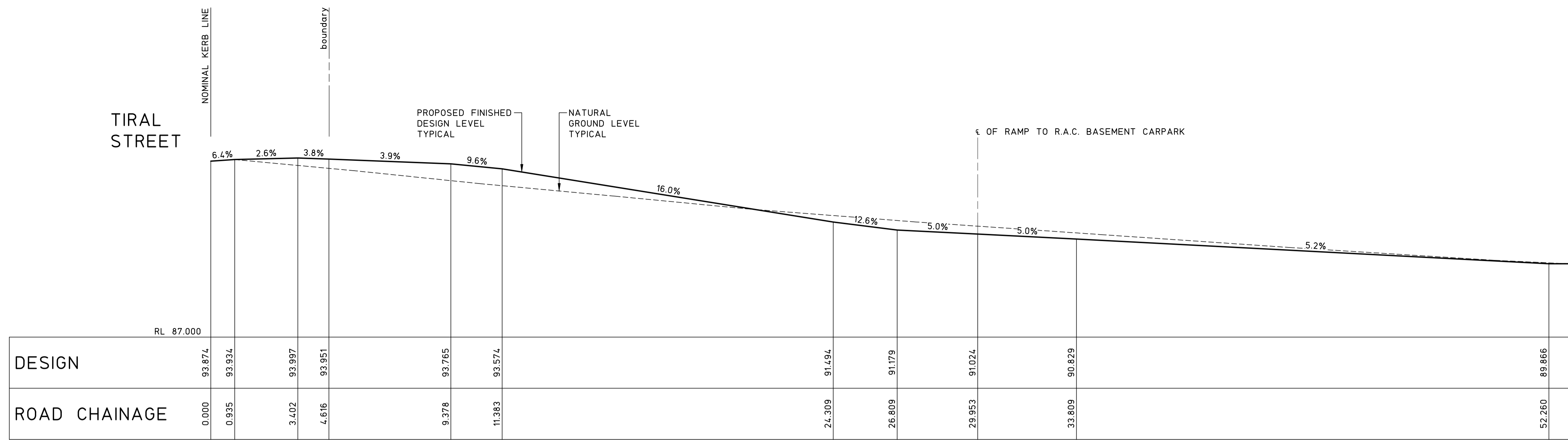

LONGITUDINAL SECTION EASTERN ACCESS ROAD

SCALE HORIZONTAL 1:100, VERTICAL 1:100

NOT FOR CONSTRUCTION

SECTION 4.55 MODIFICATION "MOD 2" NOTES
 CHANGES TO THE CIVIL DRAWINGS FOR "MOD 2" GENERALLY COMPRISE THE FOLLOWING:
 • COORDINATION WITH AMENDED GENERAL ARCHITECTURAL ARRANGEMENT

DRAWING TO BE PRINTED IN COLOUR

6 REVISED DEVELOPMENT APPLICATION - MOD 2 5 REVISED DEVELOPMENT APPLICATION - MOD 1 4 REVISED DEVELOPMENT APPLICATION 3 DEVELOPMENT APPLICATION 2 PRELIMINARY DEVELOPMENT APPLICATION 1 COORDINATION 0 80% DA - CLIENT REVIEW		3.12.25 3.9.25 25.8.22 19.8.22 12.8.22 1.7.22 19.11.21	© Copyright MPC Consulting Engineers as date of issue THIS DRAWING IS NOT TO BE USED FOR CONSTRUCTION UNLESS ENDORSED BELOW		COPYRIGHT The concepts and information contained in this document are the copyright of MPC Consulting Engineers. Use or copying of the document in whole or in part without the written permission of MPC Consulting Engineers constitutes an infringement of copyright.	Level 1, 16 Telford Street, NEWCASTLE EAST, NSW 2300 PO BOX 871 NEWCASTLE, NSW 2300 Tel: (02) 4927 5566 Email: admin@mpceng.com.au Web: www.mpceng.com.au A.C.N. 670 257 315	CLIENT UNITING TITLE STORMWATER SECTIONS SHEET 2	PROJECT PROPOSED UNITING DEVELOPMENT AT; LOT 223, DP 551260, No.27 TIRAL STREET, CHARLESTOWN	DO NOT SCALE DRAWING			
DRAWN	ENGINEER	No in SET	SHEET									
J.D.L.	B.C.	-	A1									
SCALES	JOB No	DRAWING No	ISSUE									
1:100	200243	00251	6									

FULL SIZE ON ORIGINAL 0 1 2 3 4 5 6 7 8 9 10 11 12 13 14 15 cm

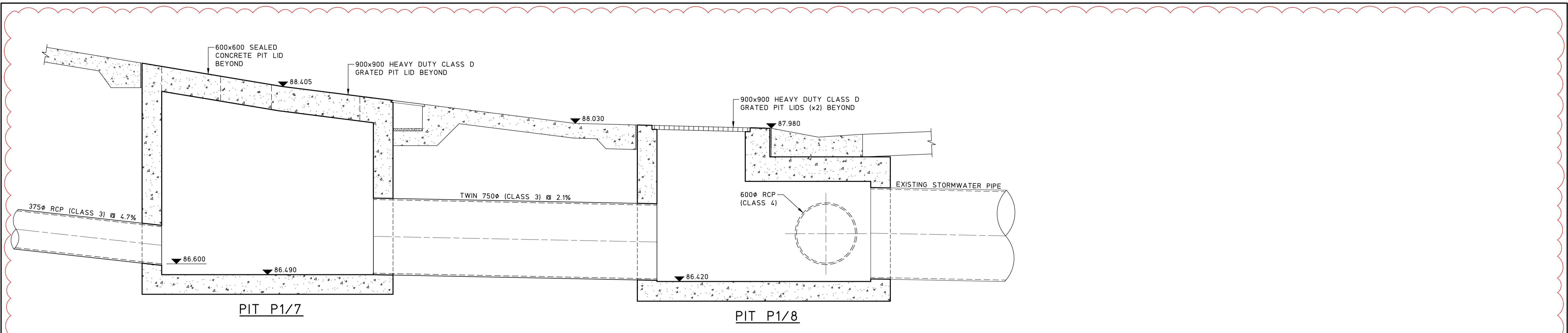

SECTION 5
SCALE 1:20
00204

NOTE
PIT DETAILS TBC AT CONSTRUCTION CERTIFICATE STAGE
TYPICAL

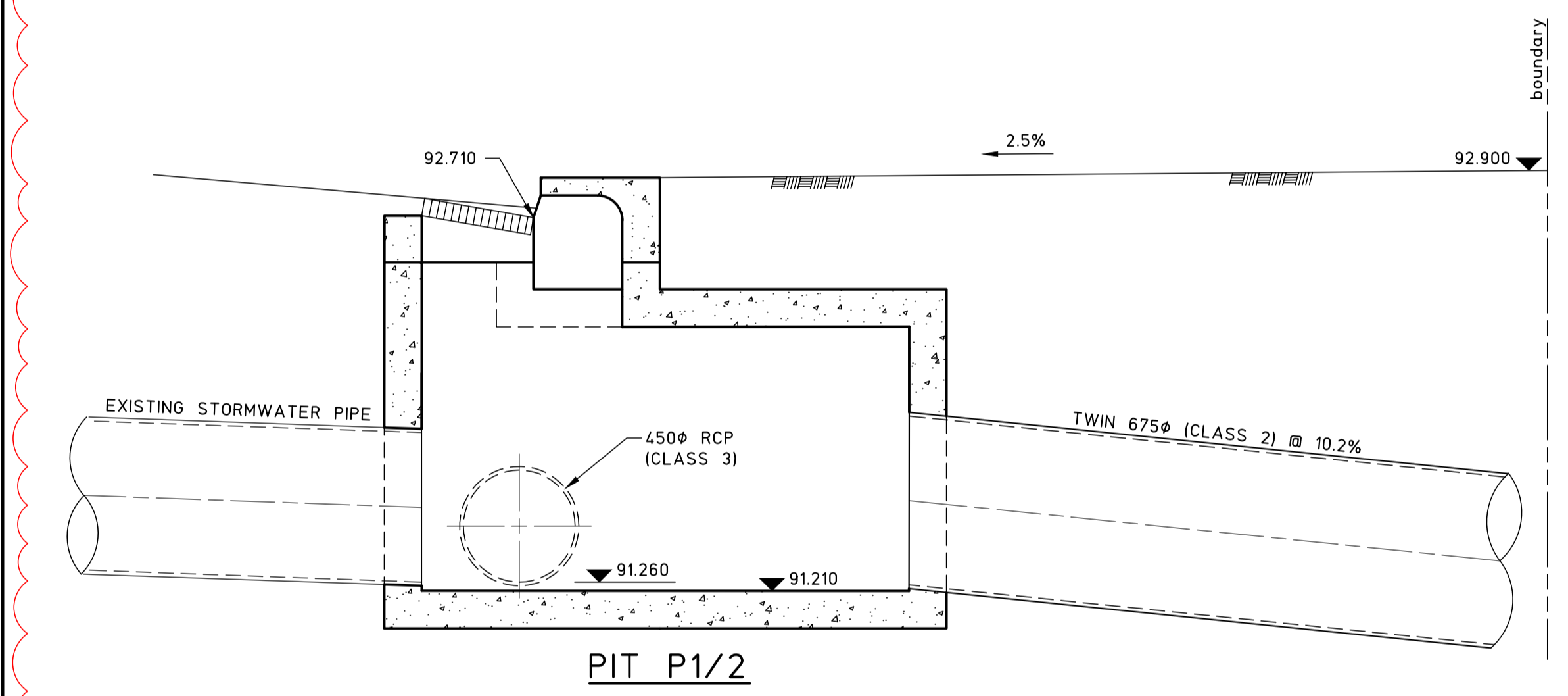

SECTION 6
SCALE 1:20
00211

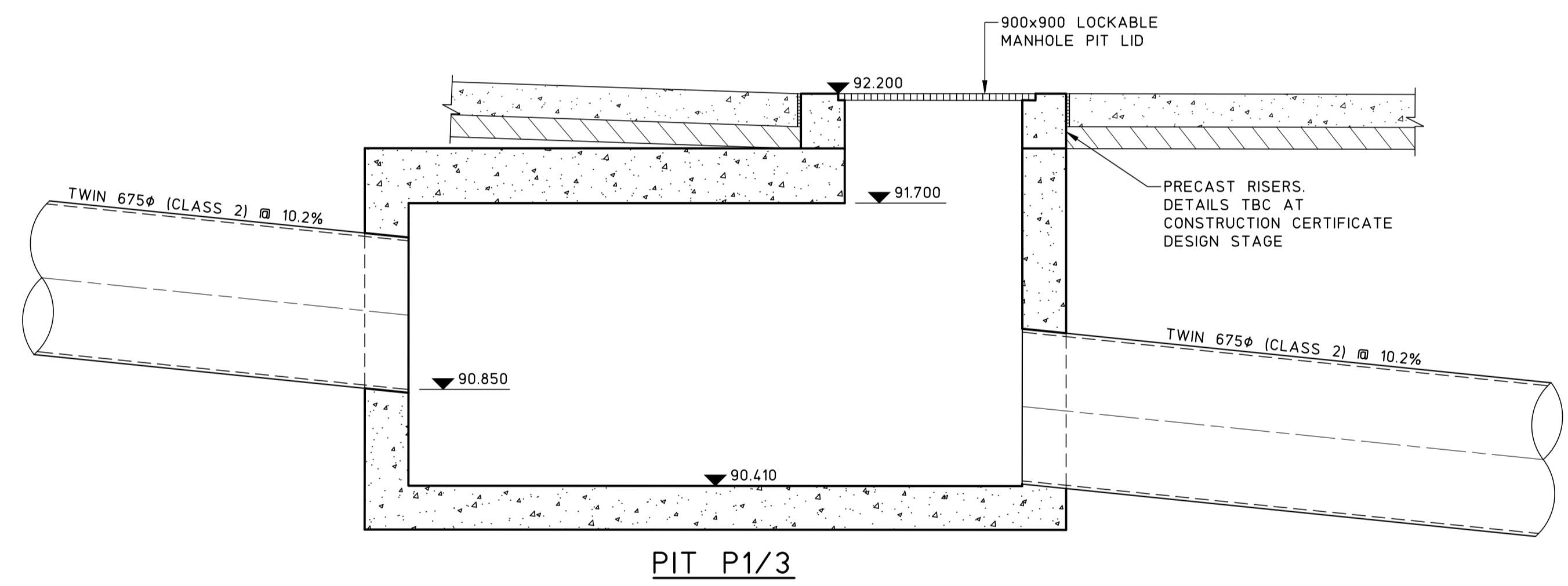

NOT FOR CONSTRUCTION

SECTION 4.55 MODIFICATION "MOD 2" NOTES
CHANGES TO THE CIVIL DRAWINGS FOR "MOD 2" GENERALLY COMPRISE THE FOLLOWING:
• COORDINATION WITH AMENDED GENERAL ARCHITECTURAL ARRANGEMENT

DRAWING TO BE PRINTED IN COLOUR

ISSUE	REASON FOR ISSUE	DATE	DATE OF RELEASE	RESPONSIBLE PRINCIPAL SIGNATURE	ISSUE
4	REVISED DEVELOPMENT APPLICATION - MOD 2	3.12.25			
3	REVISED DEVELOPMENT APPLICATION - MOD 1	3.9.25			
2	REVISED DEVELOPMENT APPLICATION	25.8.22			
1	DEVELOPMENT APPLICATION	19.8.22			
0	PRELIMINARY DEVELOPMENT APPLICATION	12.8.22			

© Copyright MPC Consulting Engineers as date of issue

THIS DRAWING IS NOT TO BE USED FOR CONSTRUCTION UNLESS ENDORSED BELOW

COPYRIGHT

The concepts and information contained in this document are the copyright of MPC Consulting Engineers. Use or copying of the document in whole or in part without the written permission of MPC Consulting Engineers constitutes an infringement of copyright.

Level 1,
16 Telford Street,
NEWCASTLE EAST, NSW 2300
PO BOX 871
NEWCASTLE, NSW 2300
Tel: (02) 4927 5566
Email: admin@mpceng.com.au
Web: www.mpceng.com.au
A.C.N. 670 257 315

CLIENT
UNITING

TITLE
**STORMWATER SECTIONS
SHEET 3**

PROJECT
**PROPOSED UNITING DEVELOPMENT AT;
LOT 223, DP 551260,
No.27 TIRAL STREET,
CHARLESTOWN**

DO NOT SCALE DRAWING			
DRAWN J.D.L.	ENGINEER B.C.	No in SET -	SHEET A1
SCALES 1:100	JOB No 200243	DRAWING No 00252	ISSUE 4

FULL SIZE ON ORIGINAL 0 1 2 3 4 5 6 7 8 9 10 11 12 13 14 15 cm

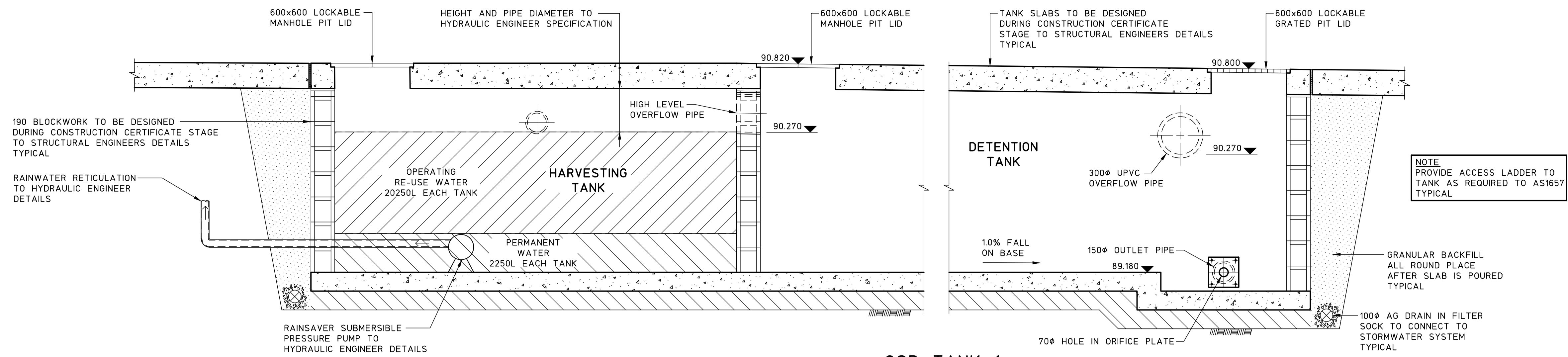

OSD TANK 1

TYPICAL OSD TANK 1 SECTION
SCALE 1:20
OSD TANK 3 SIMILAR

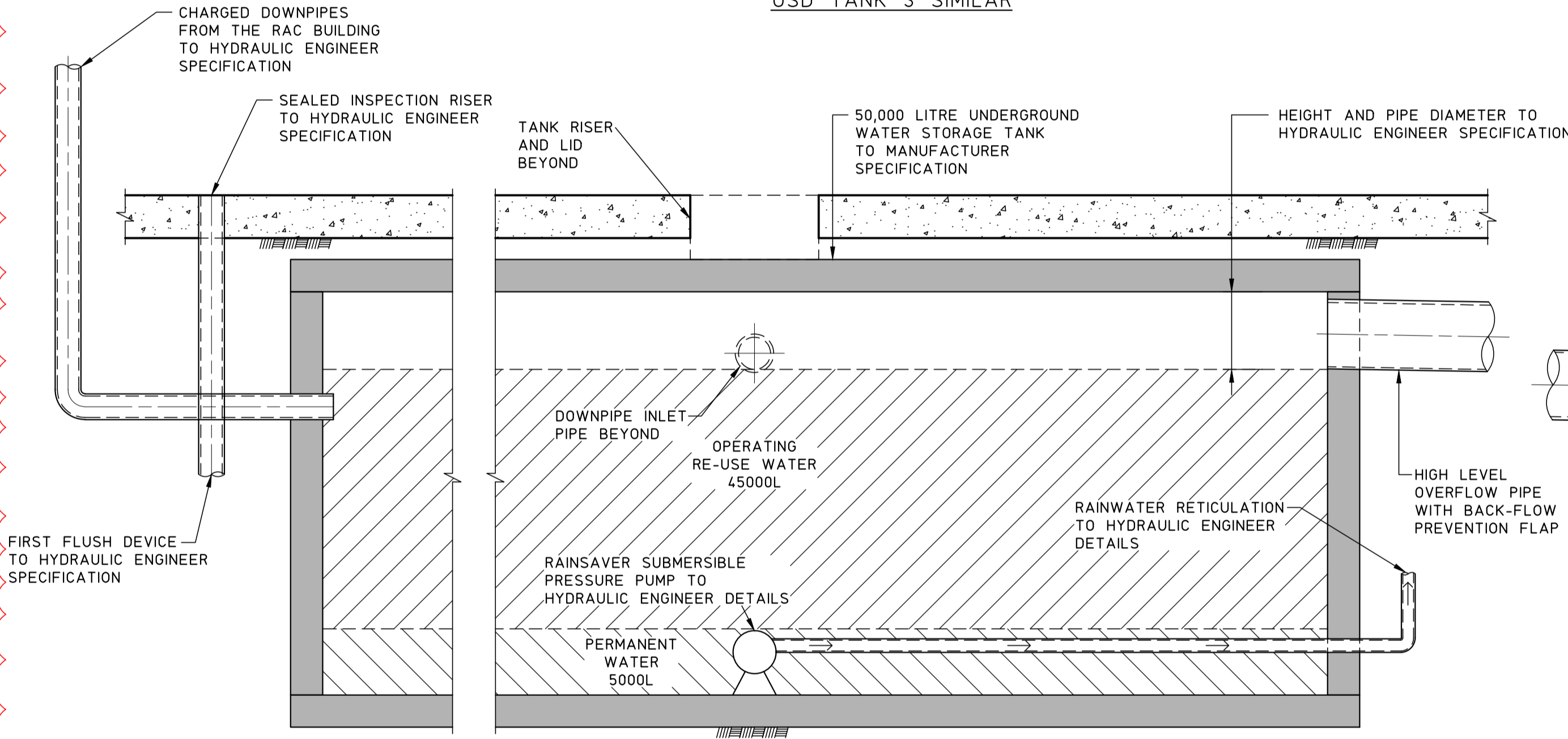

RAINWATER TANK RWT3

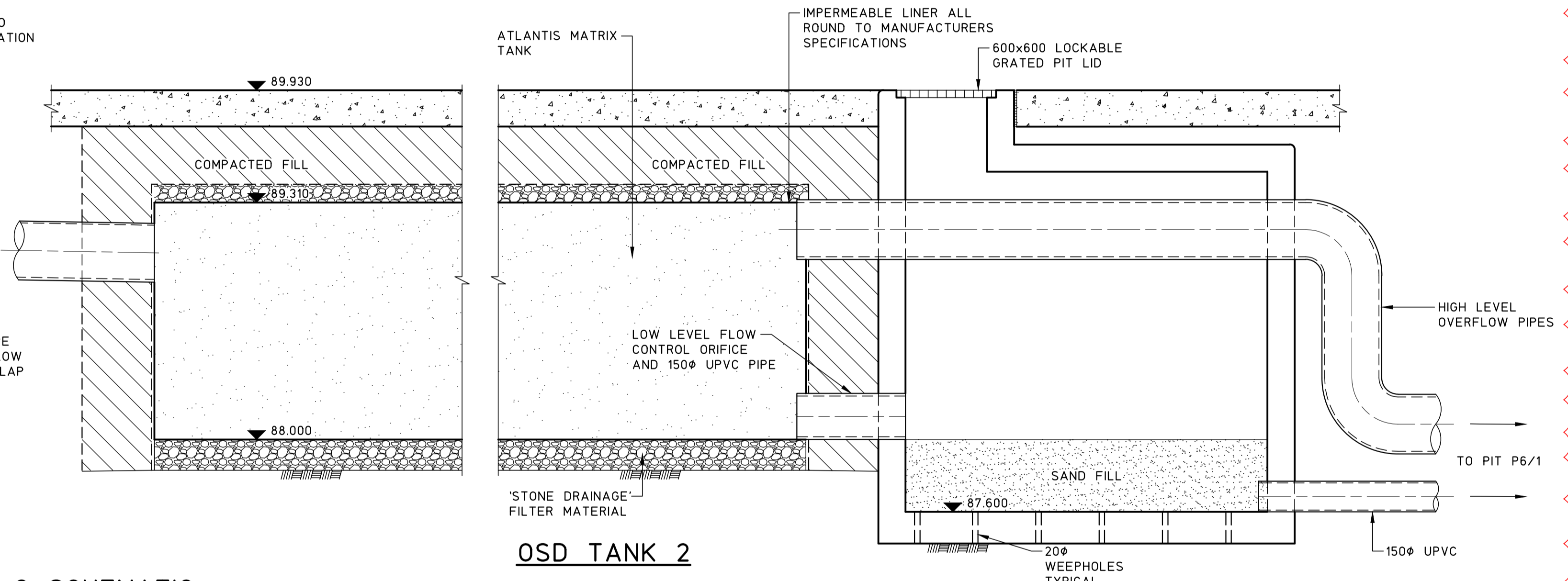

OSD TANK 2 SCHEMATIC
SCALE 1:20

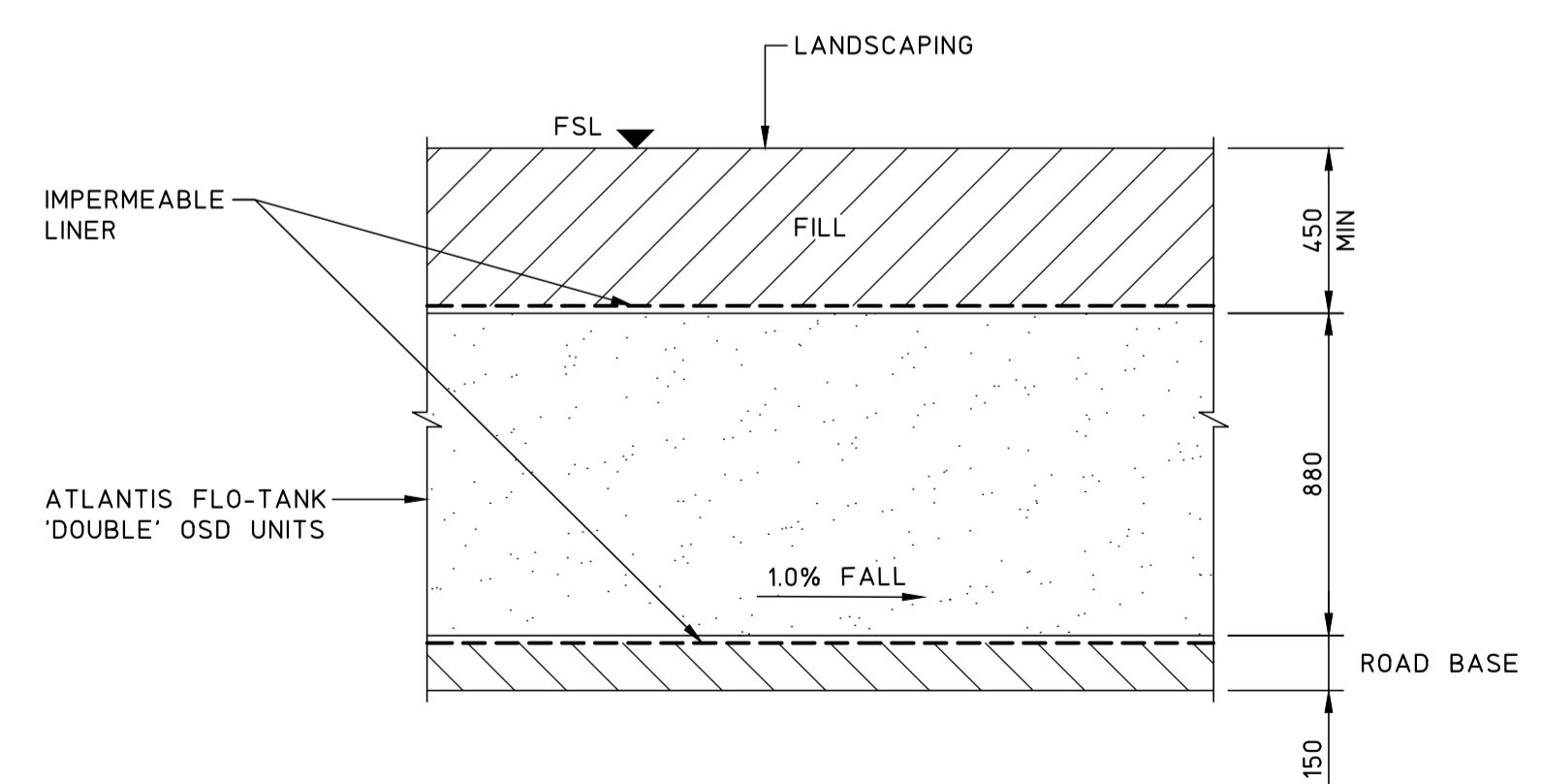

OSD TANK 4 (B, C & D) SCHEMATIC
SCALE 1:20

NOTE
PROVIDE 500 MIN OF
COMPACTED FILL AROUND
ATLANTIS MATRIX TANK
TYPICAL

- ATLANTIS MATRIX TANK NOTES**
1. TRENCHING SHALL BE CLEAR OF STRUCTURAL FOUNDATIONS WITHIN THE RANGE OF 1m (MIN) IN CLEAN SAND AND 5m (MIN) IN CLAY.
 2. THE TRENCHING SHALL BE PLACED LEVEL ALONG THE CONTOUR OF THE NATURAL OR FINISHED SURFACE.
 3. THE TRENCHING SHALL BE PLACED WITHIN THE PROPERTY TO ACHIEVE MAX. AREA, SLOPING AWAY FROM THE TRENCH, FOR DISPOSAL OF WATER.
 4. IT IS THE OWNERS RESPONSIBILITY TO REGULARLY CLEAN THE PIT AND MAINTAIN THE SYSTEM.
 5. PROVIDE 150mm INSPECTION POINTS IN ACCORDANCE WITH MANUFACTURERS SPECIFICATION

NOT FOR CONSTRUCTION

SECTION 4.55 MODIFICATION "MOD 2" NOTES
CHANGES TO THE CIVIL DRAWINGS FOR "MOD 2" GENERALLY COMPRISE THE FOLLOWING:
• COORDINATION WITH AMENDED GENERAL ARCHITECTURAL ARRANGEMENT

DRAWING TO BE PRINTED IN COLOUR

ISSUE	REASON FOR ISSUE	DATE	DATE OF RELEASE	RESPONSIBLE PRINCIPAL SIGNATURE	ISSUE
5	REVISED DEVELOPMENT APPLICATION - MOD 2	3.12.25			
4	REVISED DEVELOPMENT APPLICATION - MOD 1	3.9.25			
3	REVISED DEVELOPMENT APPLICATION	25.8.22			
2	DEVELOPMENT APPLICATION	19.8.22			
1	PRELIMINARY DEVELOPMENT APPLICATION	12.8.22			
0	COORDINATION	1.7.22			

© Copyright MPC Consulting Engineers as date of issue

THIS DRAWING IS NOT TO BE USED FOR CONSTRUCTION UNLESS ENDORSED BELOW

COPYRIGHT

The concepts and information contained in this document are the copyright of MPC Consulting Engineers. Use or copying of the document in whole or in part without the written permission of MPC Consulting Engineers constitutes an infringement of copyright.

Level 1,
16 Telford Street,
NEWCASTLE EAST, NSW 2300
PO BOX 871
NEWCASTLE, NSW 2300
Tel: (02) 4927 5566
Email: admin@mpceng.com.au
Web: www.mpceng.com.au
A.C.N. 670 257 315

CLIENT
UNITING

TITLE
STORMWATER DETAILS

SHEET 1

PROJECT
**PROPOSED UNITING DEVELOPMENT AT;
LOT 223, DP 551260,
No.27 TIRAL STREET,
CHARLESTOWN**

DO NOT SCALE DRAWING			
DRAWN	ENGINEER	No in SET	SHEET
J.D.L.	B.C.	-	A1
SCALES	JOB No	DRAWING No	ISSUE
1:20	200243	00260	5

FULL SIZE ON ORIGINAL 0 1 2 3 4 5 6 7 8 9 10 11 12 13 14 15 cm

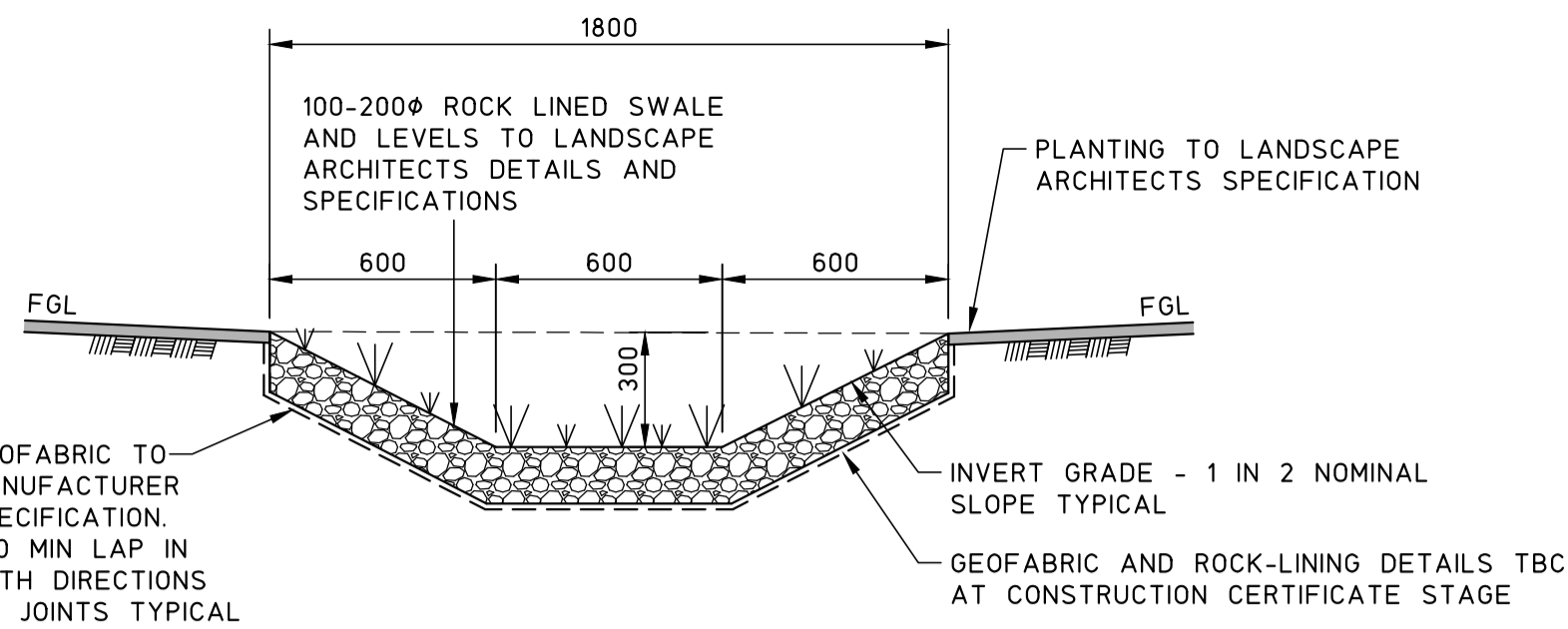

ROCK LINED SWALE - RS1
SCALE 1:20

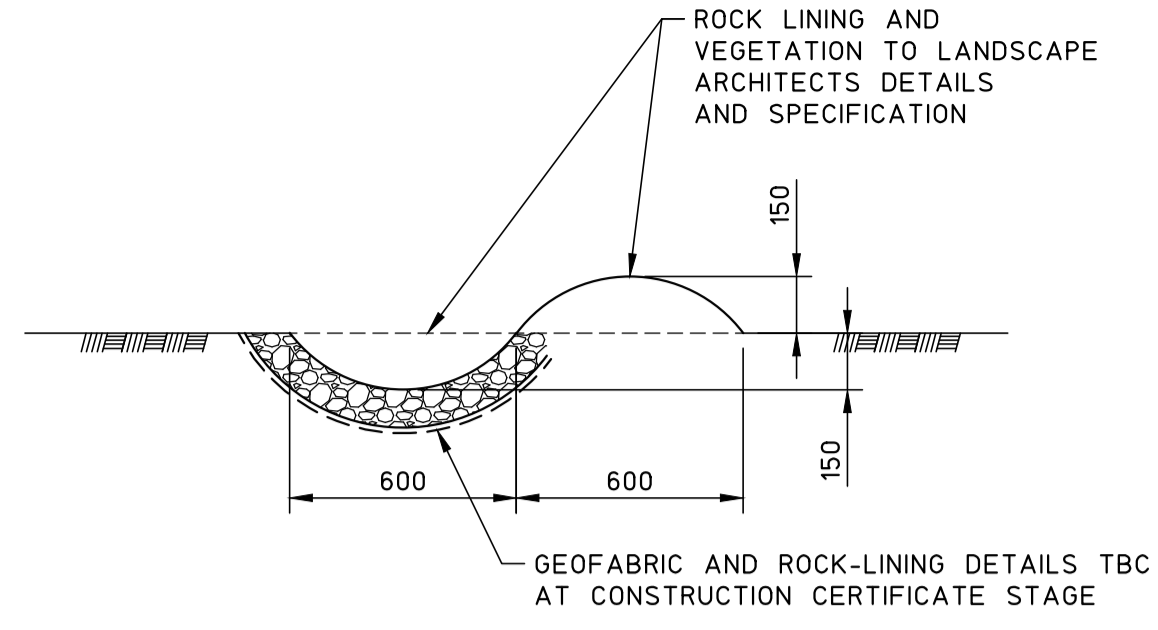

LOW-FLOW ROCK LINED SWALE - RS2
SCALE 1:20

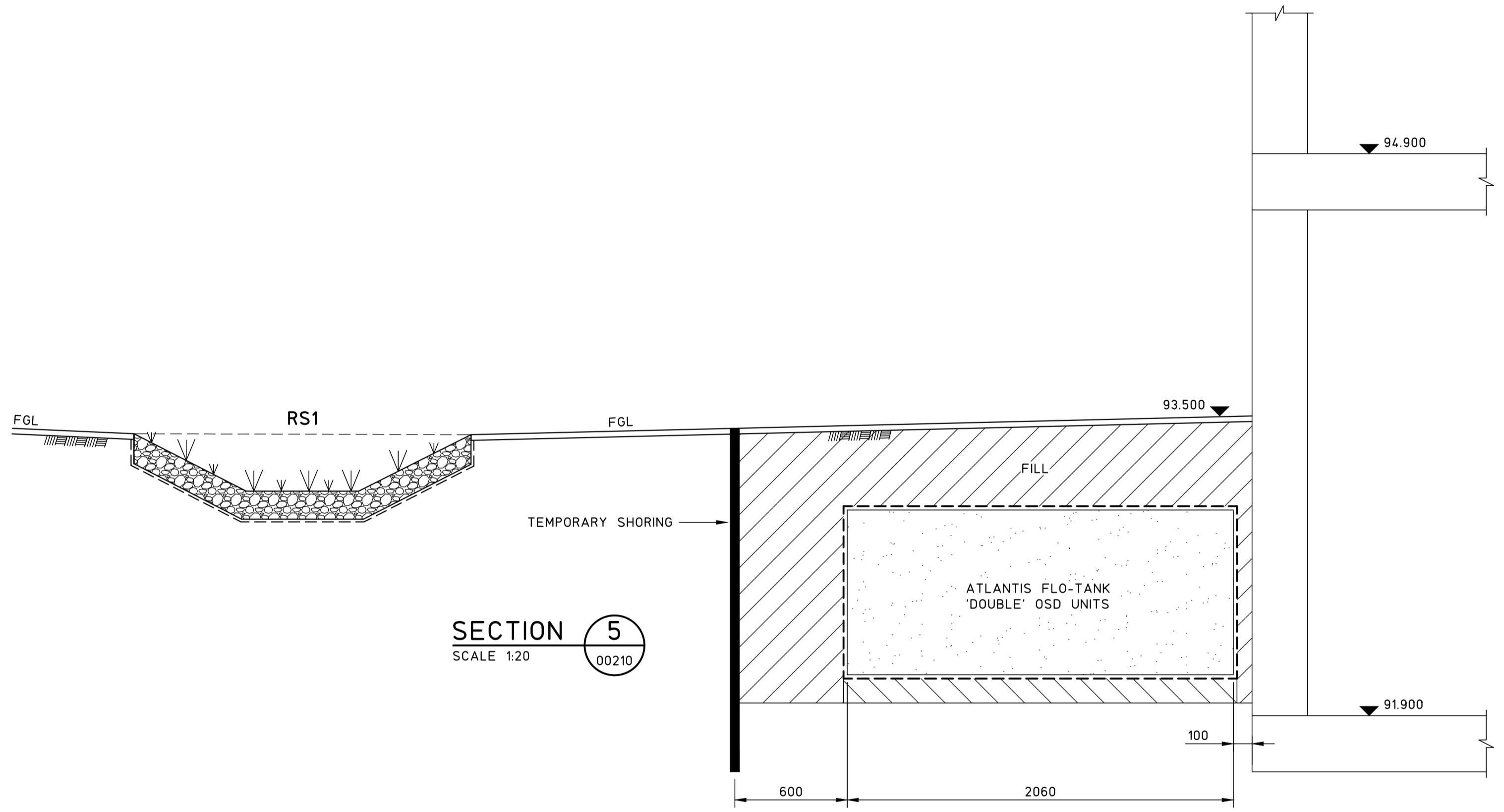

SECTION 5
SCALE 1:20
00210

NOT FOR CONSTRUCTION

SECTION 4.55 MODIFICATION "MOD 2" NOTES
CHANGES TO THE CIVIL DRAWINGS FOR "MOD 2" GENERALLY COMPRISE THE FOLLOWING:
• COORDINATION WITH AMENDED GENERAL ARCHITECTURAL ARRANGEMENT

DRAWING TO BE PRINTED IN COLOUR

5 REVISED DEVELOPMENT APPLICATION - MOD 2 3.12.25 4 REVISED DEVELOPMENT APPLICATION - MOD 1 3.9.25 3 REVISED DEVELOPMENT APPLICATION 25.8.22 2 DEVELOPMENT APPLICATION 19.8.22 1 PRELIMINARY DEVELOPMENT APPLICATION 12.8.22 0 COORDINATION 1.7.22		© Copyright MPC Consulting Engineers as date of issue THIS DRAWING IS NOT TO BE USED FOR CONSTRUCTION UNLESS ENDORSED BELOW		COPYRIGHT The concepts and information contained in this document are the copyright of MPC Consulting Engineers. Use or copying of the document in whole or in part without the written permission of MPC Consulting Engineers constitutes an infringement of copyright.		CLIENT UNITING TITLE STORMWATER DETAILS SHEET 2		PROJECT PROPOSED UNITING DEVELOPMENT AT; LOT 223, DP 551260, No.27 TIRAL STREET, CHARLESTOWN		DO NOT SCALE DRAWING					
DRAWN J.D.L.		ENGINEER B.C.		No in SET -		SHEET A1		SCALES 1:20		JOB No 200243		DRAWING No 00261		ISSUE 5	

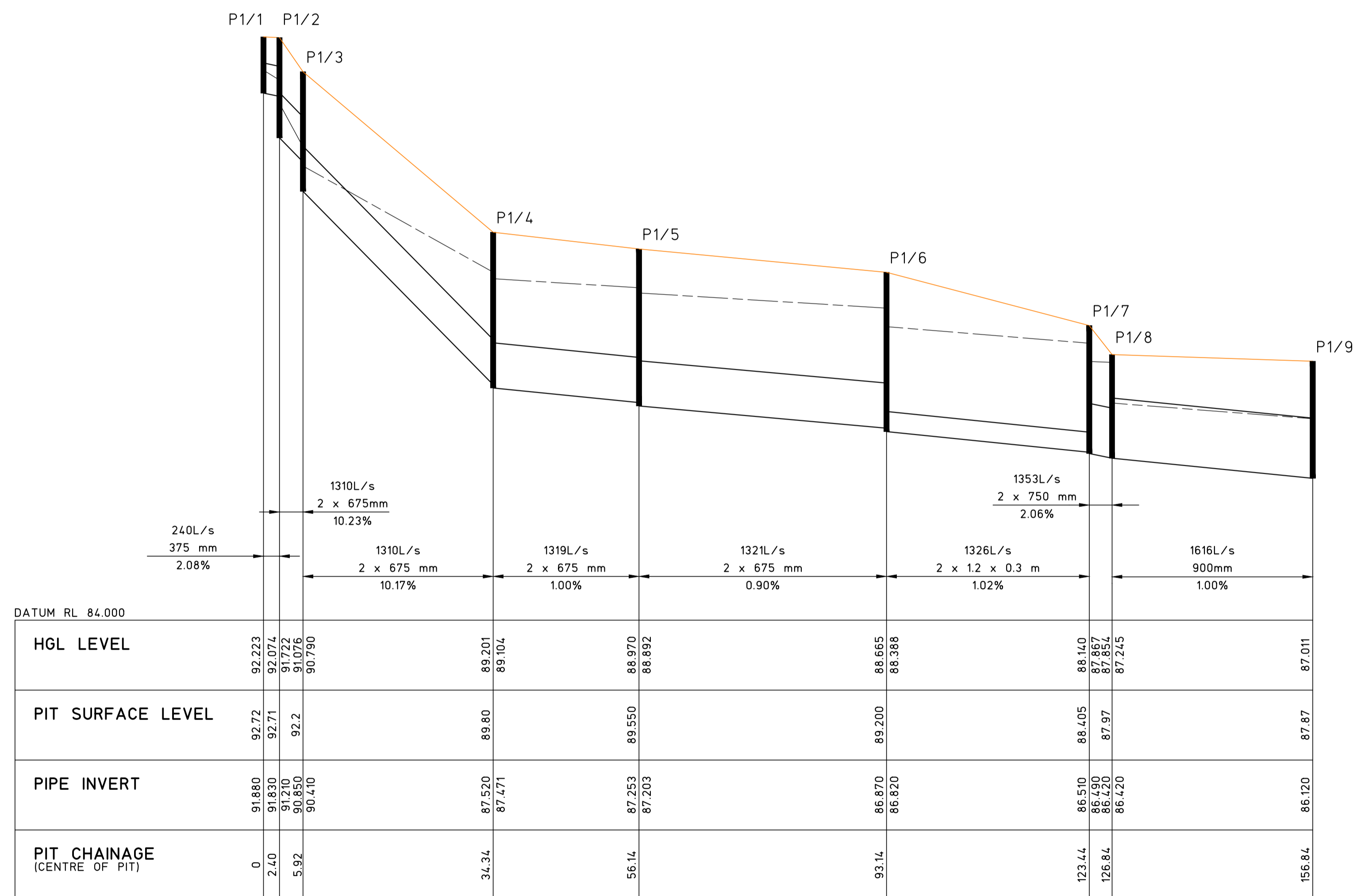

P1/1 TO P1/9 LONGITUDINAL DRAINAGE PROFILE
SCALE HORIZONTAL 1:500, VERTICAL 1:50

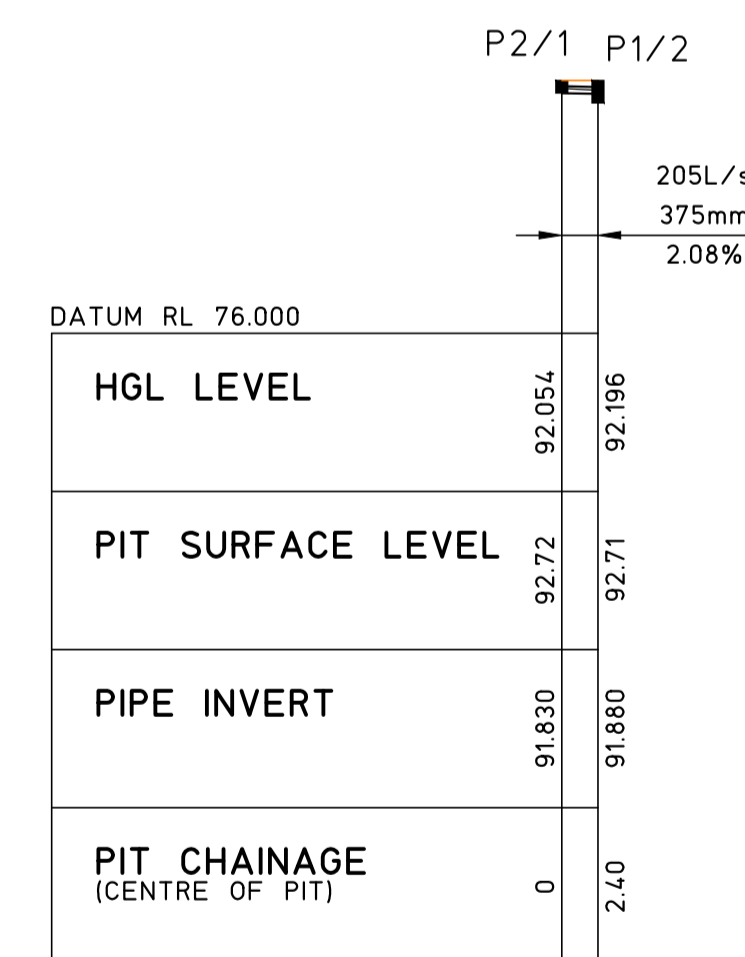

P2/1 TO P1/2 LONGITUDINAL DRAINAGE PROFILE
SCALE HORIZONTAL 1:500, VERTICAL 1:50

NOT FOR CONSTRUCTION

SECTION 4.55 MODIFICATION "MOD 2" NOTES
CHANGES TO THE CIVIL DRAWINGS FOR "MOD 2" GENERALLY COMPRISE THE FOLLOWING:
• COORDINATION WITH AMENDED GENERAL ARCHITECTURAL ARRANGEMENT

DRAWING TO BE PRINTED IN COLOUR

© Copyright MPC Consulting Engineers as date of issue		COPYRIGHT		CLIENT		PROJECT		DO NOT SCALE DRAWING				
THIS DRAWING IS NOT TO BE USED FOR CONSTRUCTION UNLESS ENDORSED BELOW		The concepts and information contained in this document are the copyright of MPC Consulting Engineers. Use or copying of the document in whole or in part without the written permission of MPC Consulting Engineers constitutes an infringement of copyright.		Level 1, 16 Telford Street, NEWCASTLE EAST, NSW 2300 PO BOX 871 NEWCASTLE, NSW 2300 Tel: (02) 4927 5566 Email: admin@mpceng.com.au Web: www.mpceng.com.au A.C.N. 670 257 315		UNITING		PROPOSED UNITING DEVELOPMENT AT; LOT 223, DP 551260, No.27 TIRAL STREET, CHARLESTOWN				
2	REVISED DEVELOPMENT APPLICATION - MOD 2	3.12.25				TITLE		DRAWN		ENGINEER	No in SET	SHEET
1	REVISED DEVELOPMENT APPLICATION - MOD 1	3.9.25				STORMWATER LINES LONGITUDINAL DRAINAGE PROFILES SHEET 1		J.D.L.		B.C.	-	A1
0	REVISED DEVELOPMENT APPLICATION	25.8.22						SCALES		JOB No	DRAWING No	ISSUE
ISSUE	REASON FOR ISSUE	DATE	DATE OF RELEASE	RESPONSIBLE PRINCIPAL SIGNATURE	ISSUE			AS SHOWN		200243	00253	2

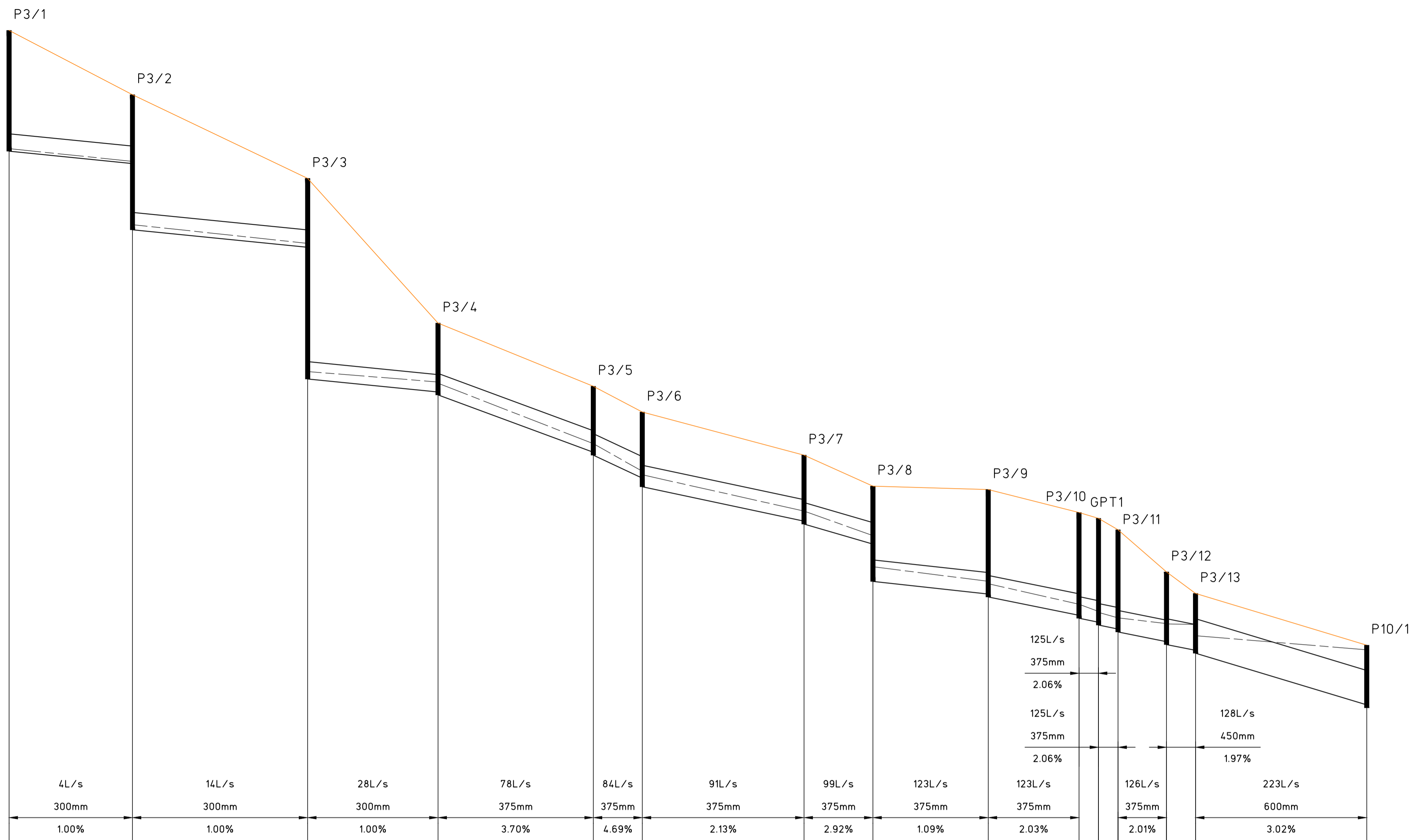

DATUM RL 84.000	
HGL LEVEL	96.640 96.417 95.315 94.989 92.756 92.575 92.553 91.501 91.501 91.019 90.958 90.326 90.326 89.899 89.356 89.102 89.061 88.703 88.703 88.703 88.703 88.561 88.466 88.366 88.366 88.361 88.155 87.909
PIT SURFACE LEVEL	98.70 97.58 96.12 93.600 92.5 92.05 91.3 90.76 90.7 90.3 90.3 90.20 90 89.265 88.89 87.99
PIPE INVERT	96.595 96.380 95.225 94.920 92.627 92.400 92.350 91.350 91.300 90.900 90.750 90.150 90.100 89.750 89.100 88.680 88.830 88.510 88.460 88.460 88.270 88.340 88.220 88.050 88.000 87.900 87.850 86.950
PIT CHAINAGE (CENTRE OF PIT)	0 21.50 52.02 74.72 101.77 110.30 138.47 150.47 170.57 186.37 189.77 193.17 201.61 206.68 236.49

P3/1 TO P10/1 LONGITUDINAL DRAINAGE PROFILE
SCALE HORIZONTAL 1:500, VERTICAL 1:50

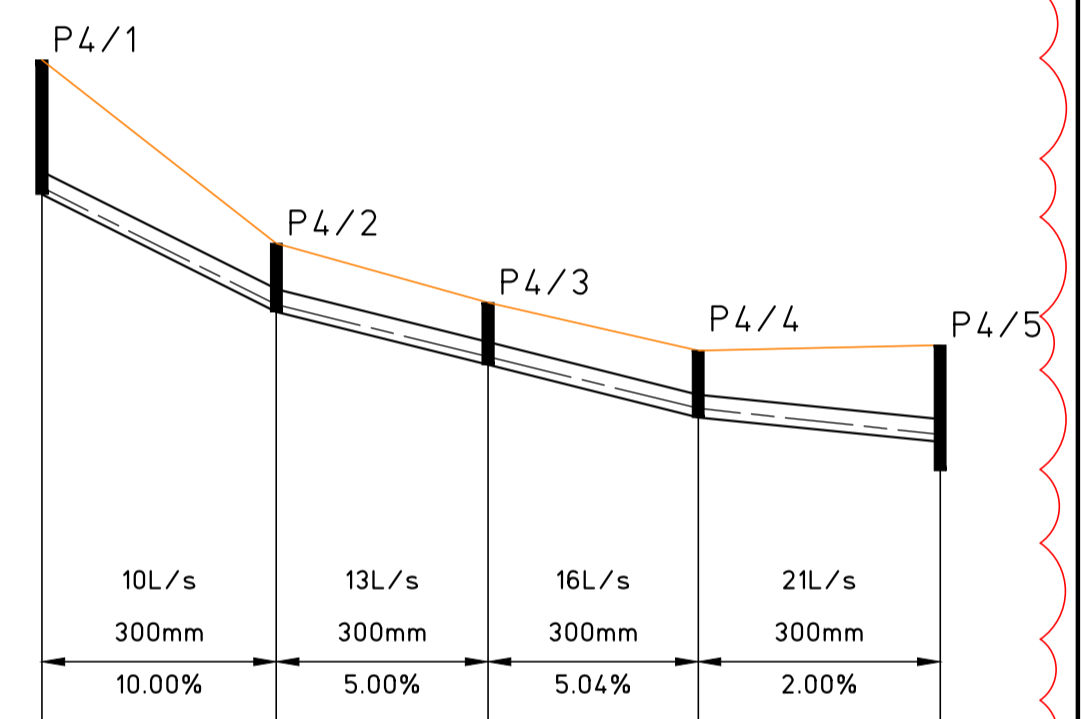

DATUM RL 84.000	
HGL LEVEL	91.943 90.394 90.394 89.704 89.704 89.023 89.023 88.678
PIT SURFACE LEVEL	93.63 91.206 90.422 89.787 89.023 88.678
PIPE INVERT	91.650 90.300 90.300 89.600 89.600 88.900 88.900 88.580
PIT CHAINAGE (CENTRE OF PIT)	0 15.50 29.50 43.40 59.40

P4/1 TO P4/5 LONGITUDINAL DRAINAGE PROFILE
SCALE HORIZONTAL 1:500, VERTICAL 1:100

NOT FOR CONSTRUCTION

SECTION 4.55 MODIFICATION "MOD 2" NOTES
CHANGES TO THE CIVIL DRAWINGS FOR "MOD 2" GENERALLY COMPRISE THE FOLLOWING:
• COORDINATION WITH AMENDED GENERAL ARCHITECTURAL ARRANGEMENT

DRAWING TO BE PRINTED IN COLOUR

© Copyright MPC Consulting Engineers as date of issue THIS DRAWING IS NOT TO BE USED FOR CONSTRUCTION UNLESS ENDORSED BELOW		COPYRIGHT The concepts and information contained in this document are the copyright of MPC Consulting Engineers. Use or copying of the document in whole or in part without the written permission of MPC Consulting Engineers constitutes an infringement of copyright.				CLIENT UNITING TITLE STORMWATER LINES LONGITUDINAL DRAINAGE PROFILES SHEET 2		PROJECT PROPOSED UNITING DEVELOPMENT AT; LOT 223, DP 551260, No.27 TIRAL STREET, CHARLESTOWN		DO NOT SCALE DRAWING			
2	REVISED DEVELOPMENT APPLICATION - MOD 2	3.12.25								DRAWN	ENGINEER	No in SET	SHEET
1	REVISED DEVELOPMENT APPLICATION - MOD 1	3.9.25								J.D.L.	B.C.	-	A1
0	REVISED DEVELOPMENT APPLICATION	25.8.22								SCALES	JOB No	DRAWING No	ISSUE
	REASON FOR ISSUE	DATE	DATE OF RELEASE	RESPONSIBLE PRINCIPAL SIGNATURE	ISSUE					AS SHOWN	200243	00254	2

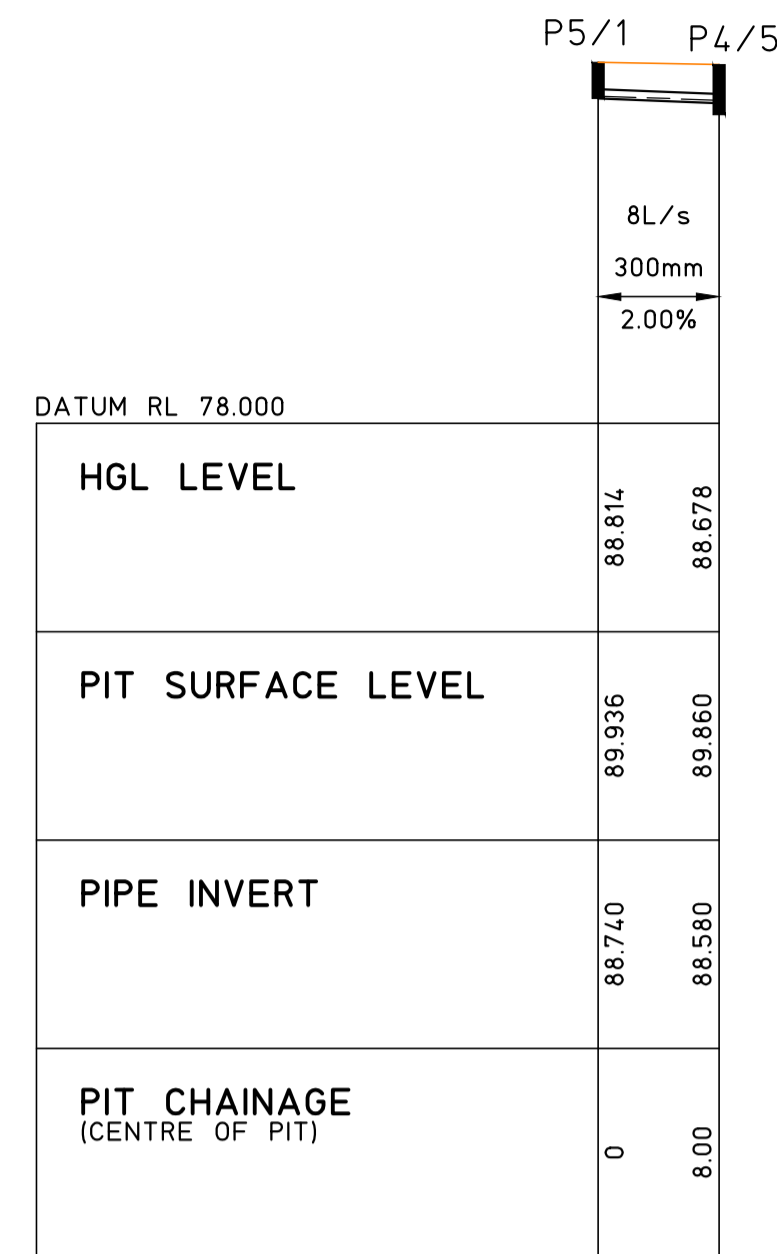

P5/1 TO P4/5
LONGITUDINAL DRAINAGE PROFILE
 SCALE HORIZONTAL 1:500, VERTICAL 1:250

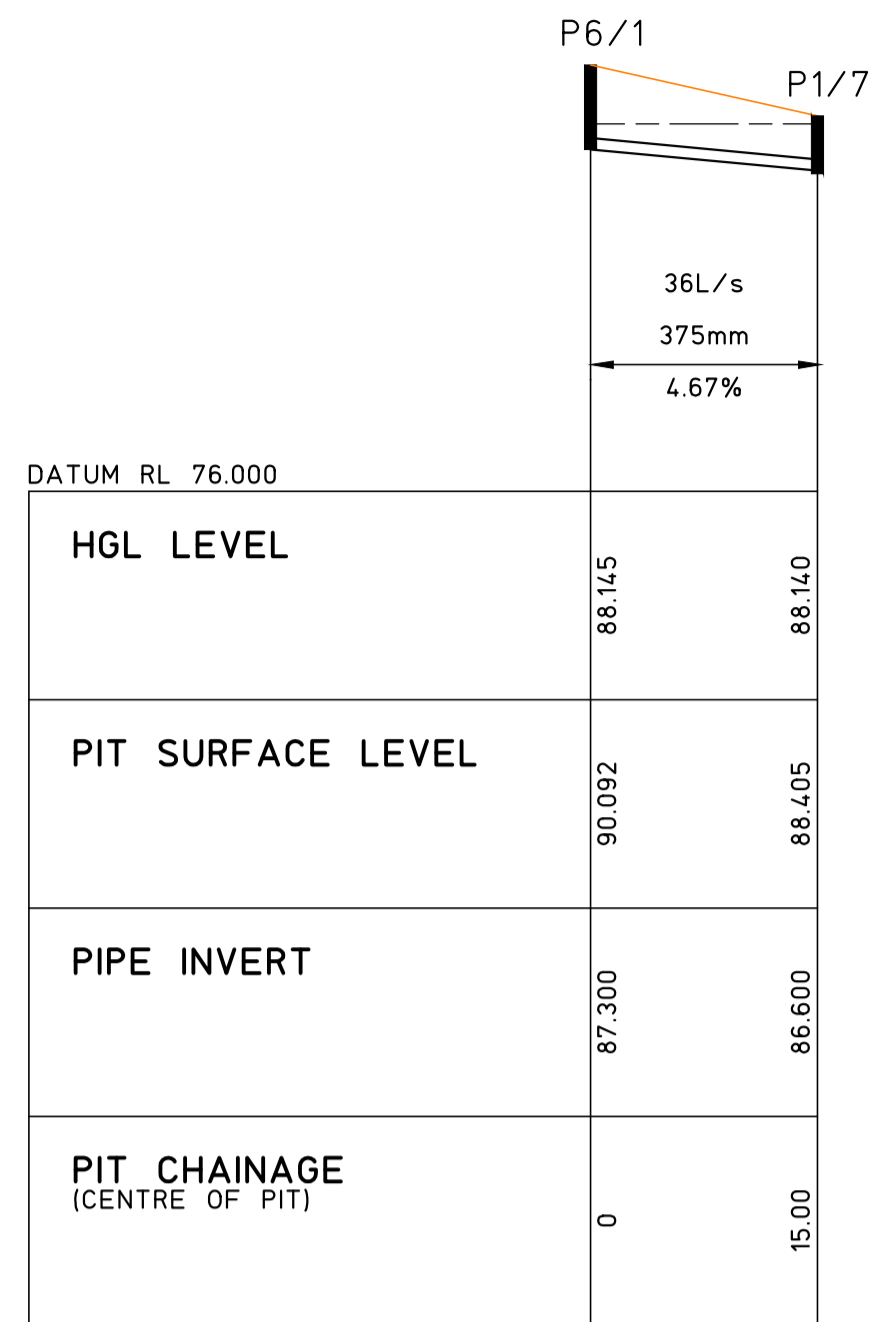

P6/1 TO P1/7
LONGITUDINAL DRAINAGE PROFILE
 SCALE HORIZONTAL 1:500, VERTICAL 1:250

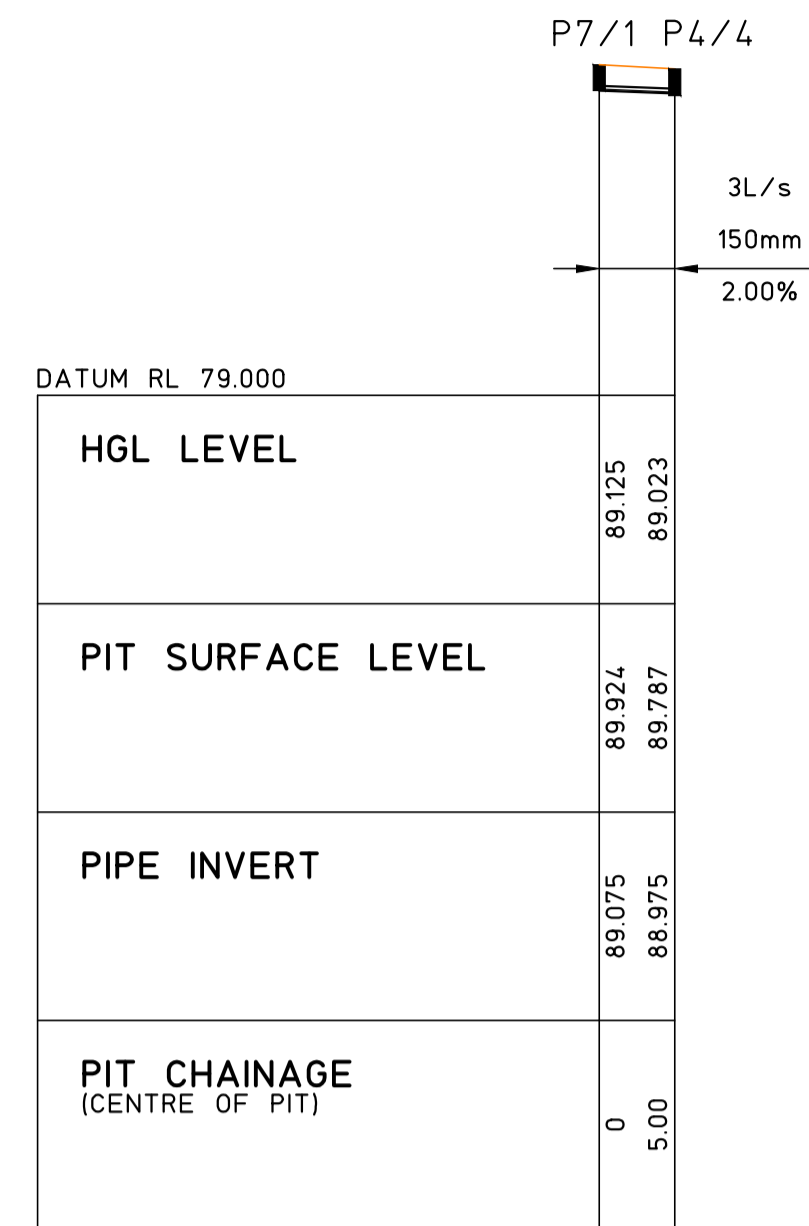

P7/1 TO P4/4
LONGITUDINAL DRAINAGE PROFILE
 SCALE HORIZONTAL 1:500, VERTICAL 1:250

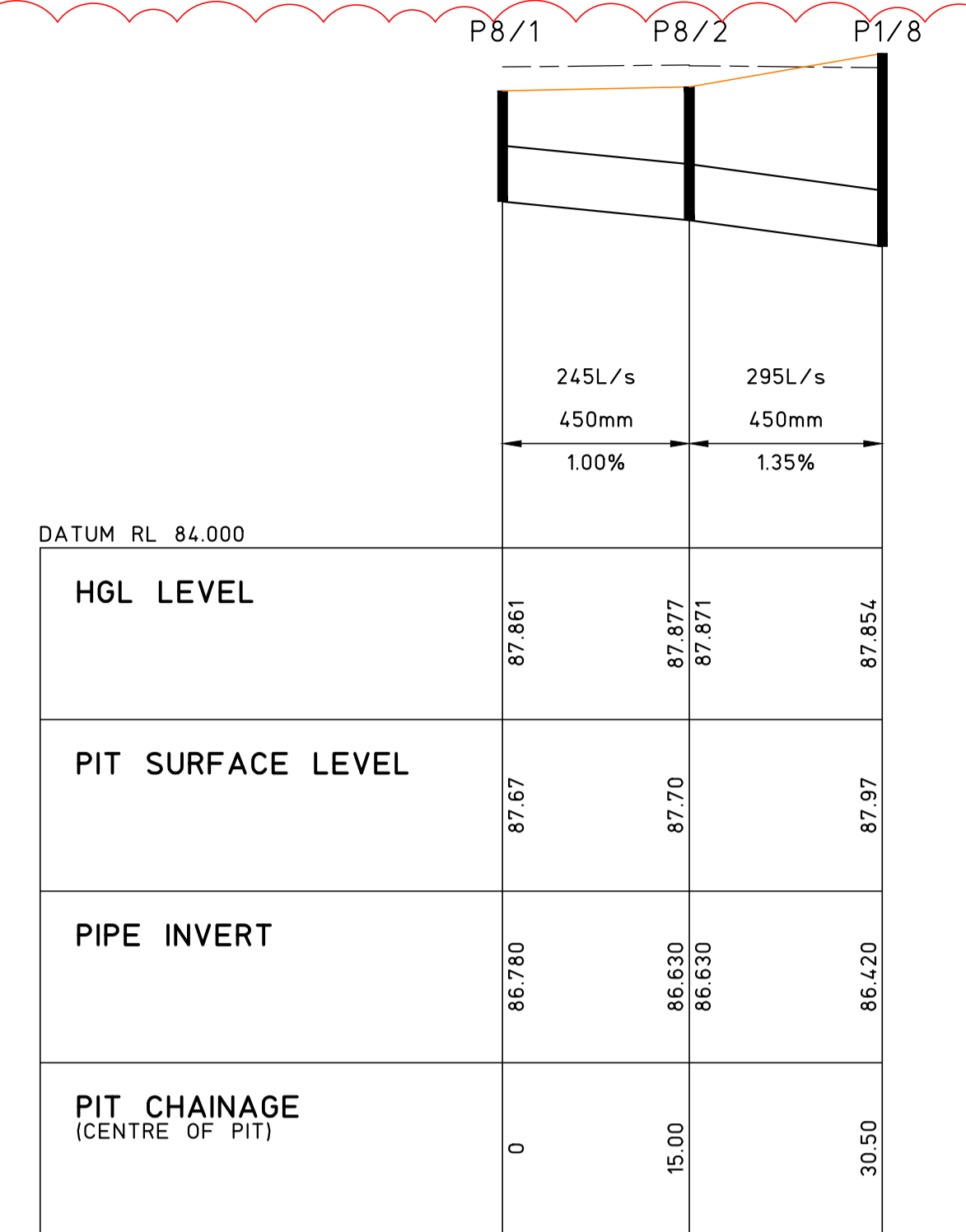

P8/1 TO P1/8
LONGITUDINAL DRAINAGE PROFILE
 SCALE HORIZONTAL 1:500, VERTICAL 1:50

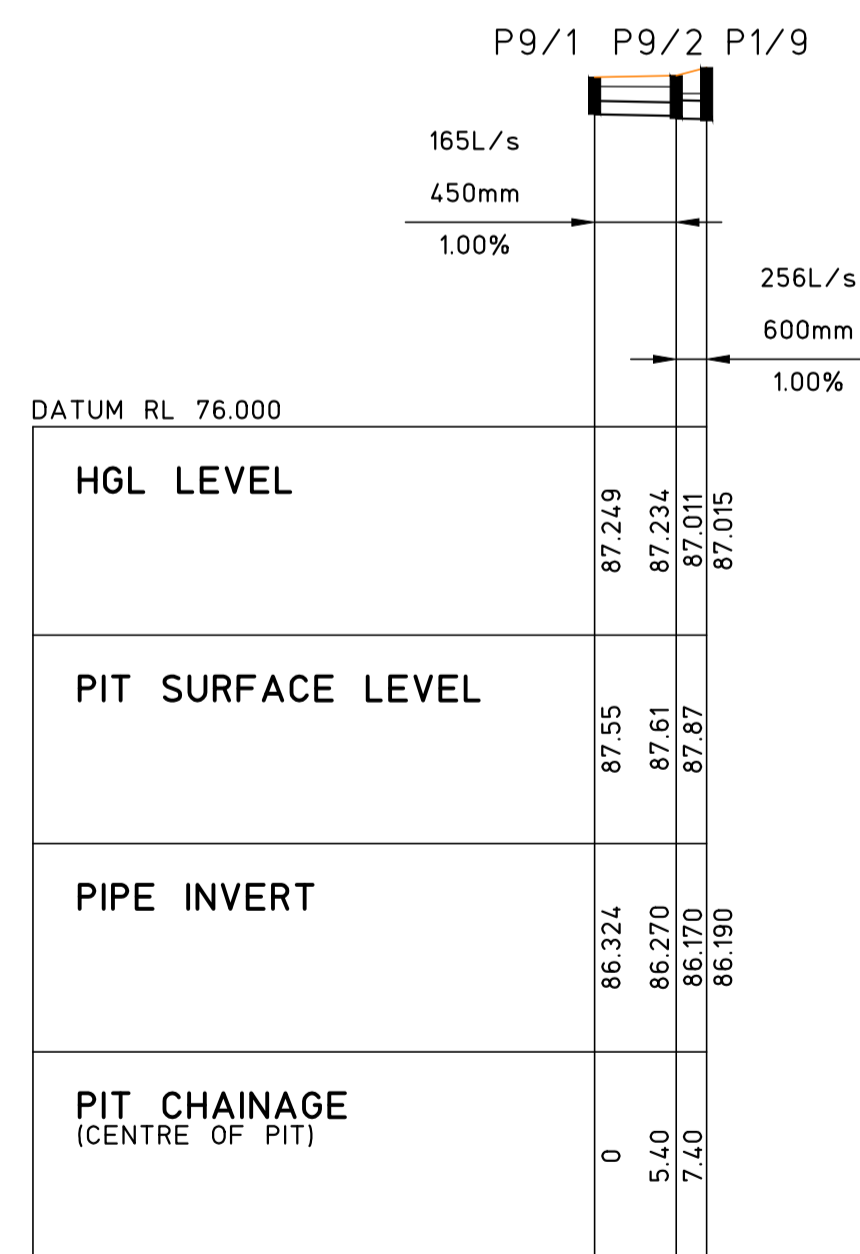

P9/1 TO P1/9
LONGITUDINAL DRAINAGE PROFILE
 SCALE HORIZONTAL 1:500, VERTICAL 1:250

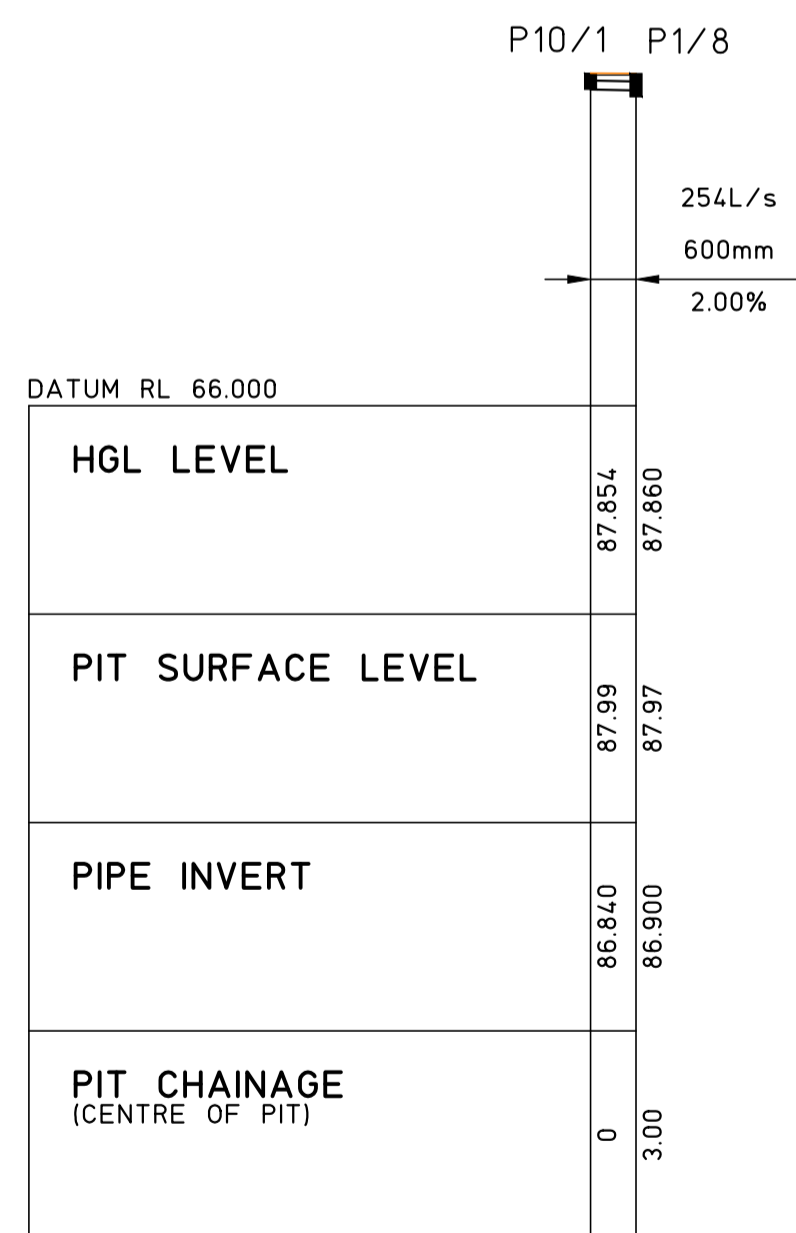

P10/1 TO P1/8
LONGITUDINAL DRAINAGE PROFILE
 SCALE HORIZONTAL 1:500, VERTICAL 1:500

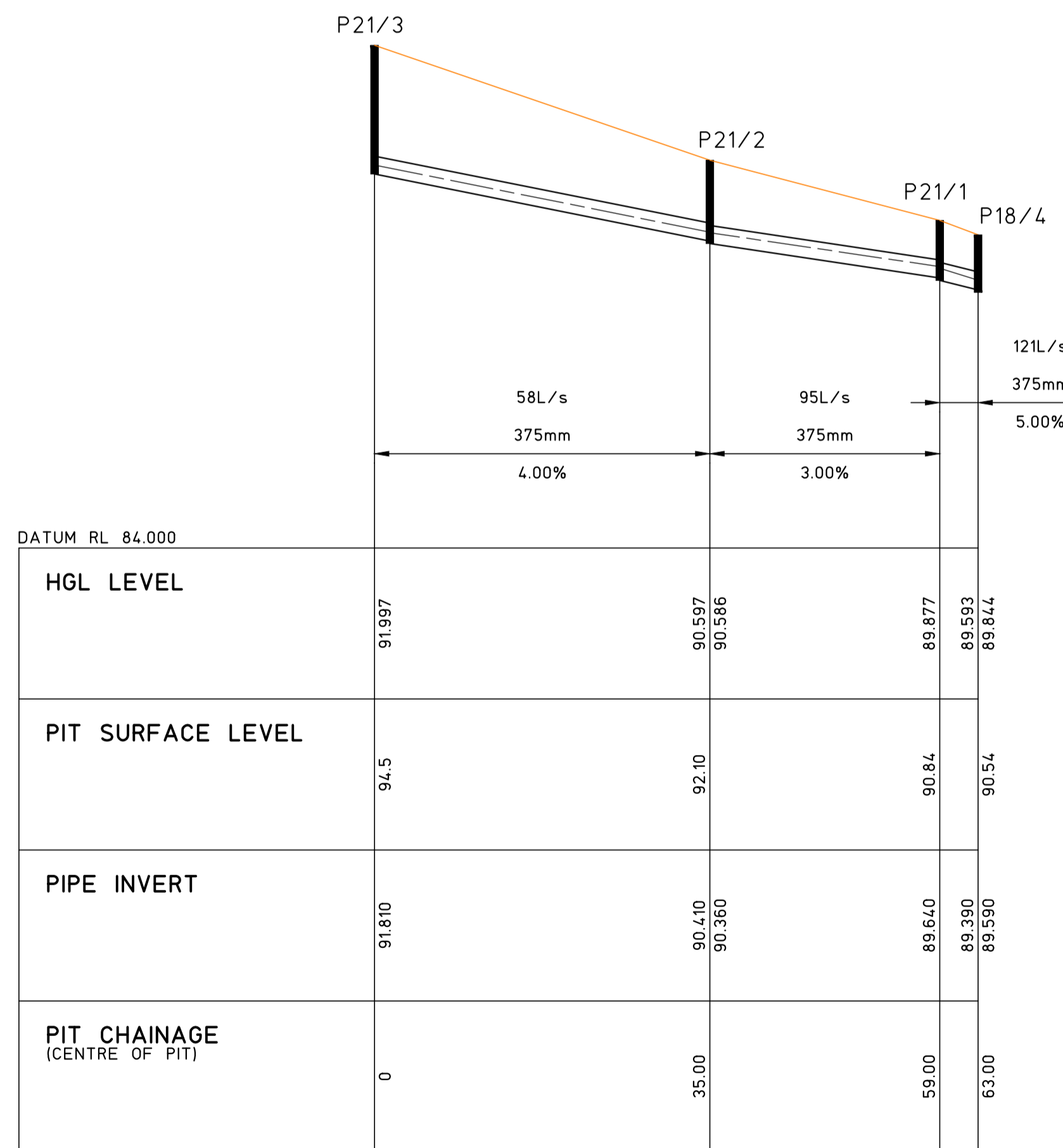

P21/3 TO P18/4
LONGITUDINAL DRAINAGE PROFILE
 SCALE HORIZONTAL 1:500, VERTICAL 1:100

NOT FOR CONSTRUCTION

SECTION 4.55 MODIFICATION "MOD 2" NOTES
 CHANGES TO THE CIVIL DRAWINGS FOR "MOD 2" GENERALLY COMPRISE THE FOLLOWING:
 • COORDINATION WITH AMENDED GENERAL ARCHITECTURAL ARRANGEMENT

DRAWING TO BE PRINTED IN COLOUR

© Copyright MPC Consulting Engineers as date of issue THIS DRAWING IS NOT TO BE USED FOR CONSTRUCTION UNLESS ENDORSED BELOW		COPYRIGHT The concepts and information contained in this document are the copyright of MPC Consulting Engineers. Use or copying of the document in whole or in part without the written permission of MPC Consulting Engineers constitutes an infringement of copyright.				CLIENT UNITING TITLE STORMWATER LINES LONGITUDINAL DRAINAGE PROFILES SHEET 3		PROJECT PROPOSED UNITING DEVELOPMENT AT; LOT 223, DP 551260, No.27 TIRAL STREET, CHARLESTOWN		DO NOT SCALE DRAWING			
2	REVISED DEVELOPMENT APPLICATION - MOD 2	3.12.25								DRAWN J.D.L.	ENGINEER B.C.	No in SET -	SHEET A1
1	REVISED DEVELOPMENT APPLICATION - MOD 1	3.9.25								SCALES AS SHOWN	JOB No 200243	DRAWING No 00255	ISSUE 2
0	REVISED DEVELOPMENT APPLICATION	25.8.22											
ISSUE	REASON FOR ISSUE	DATE	DATE OF RELEASE	RESPONSIBLE PRINCIPAL SIGNATURE	ISSUE								