



# Public Viewpoint Analysis

Appendix A

Viewpoint:

# VP01 Intersection of Golden Highway and Spring Ridge Road, Cobbora, NSW

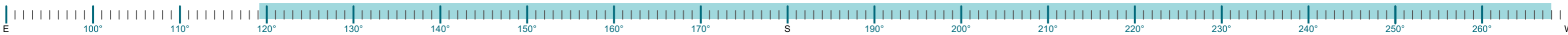

Maximum Extent of Project

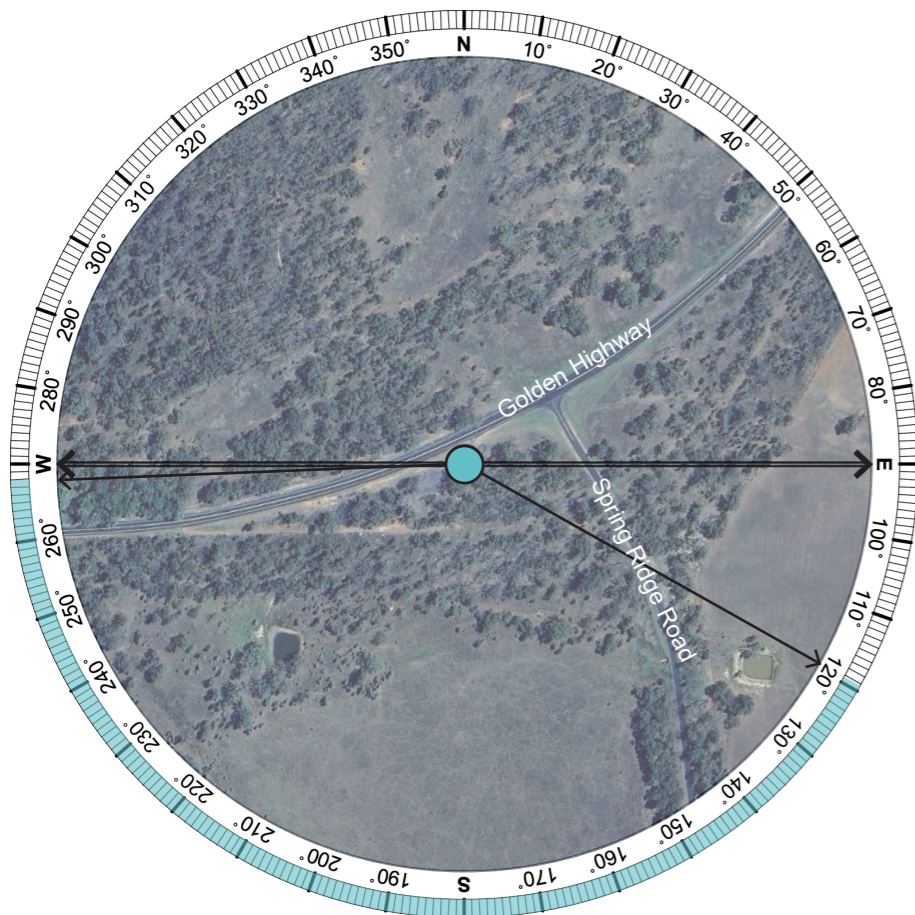

Aerial Source: Google Earth, 2023

### Viewpoint Summary:

Location:	Elevation:
Intersection of Golden Highway and Spring Ridge Road, Cobbora	392 m
Coordinates:	Distance to Project:
32° 6'19.85"S 149°13'42.03"E	0.07 km

### Viewing Direction:

South

### Visual Sensitivity:

VERY LOW

### Visual Magnitude:

LOW

### Visual Impact:

**VERY LOW**

→ Extent of Panorama

→ Approximate Extent of Project

### Existing Landscape Character Description:

This viewpoint is located on a gravel pull over area, near the intersection of the Golden Highway and Spring Ridge Road, looking south toward the Project.

The surrounding landscape is characterised by an open gravel area, with dense roadside vegetation, screening views of pastures in the background of the view.

The surrounding landuse is a mix of native woodland and pastures, utilised for grazing.

The visual sensitivity of this viewpoint has been rated as **VERY LOW**.

### Potential Visual Impact:

Despite the close proximity, intervening roadside vegetation will screen views towards the project.

The visual magnitude of change is **LOW**, resulting in a **VERY LOW** visual impact.

Viewpoint:

# VP02 Golden Highway Rest Area, Elong Elong, NSW



Maximum Extent of Project

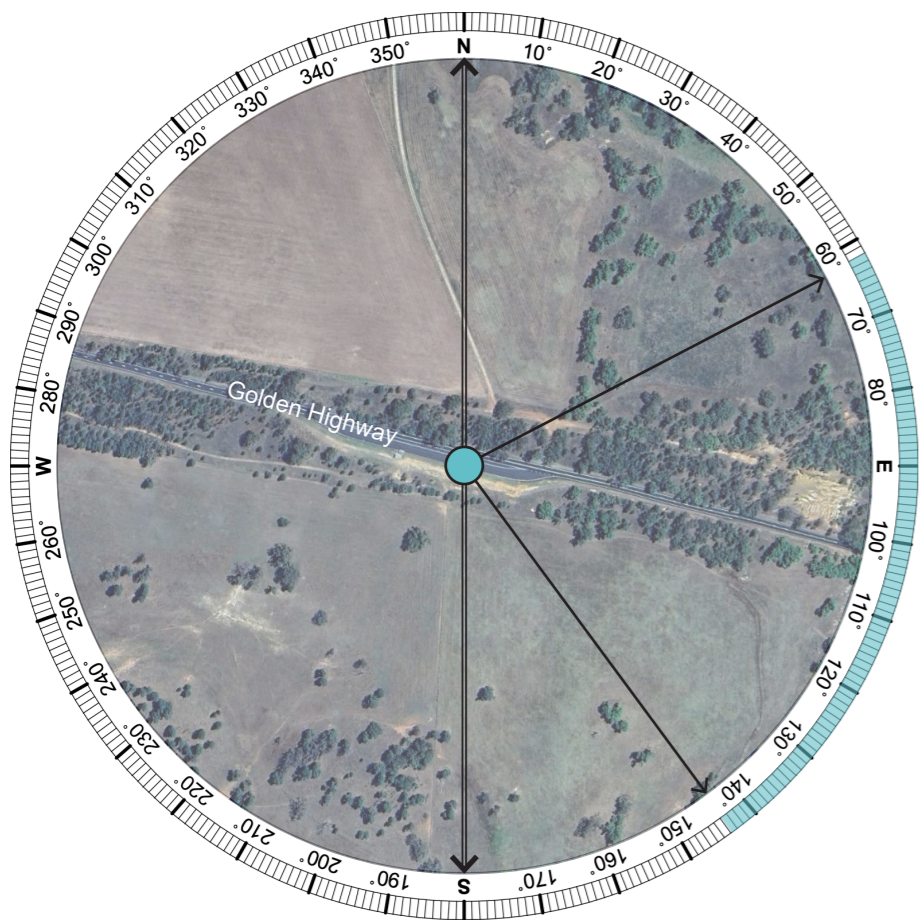

Aerial Source: Google Earth, 2023

### Viewpoint Summary:

Location:	Elevation:
Golden Highway Rest Area, Elong Elong, NSW	356 m
Coordinates:	Distance to Project:
32° 7'29.80"S 149° 9'11.21"E	2.81 km
Viewing Direction:	
East	
Visual Sensitivity:	
LOW	
Visual Magnitude:	
VERY LOW	
Visual Impact:	
<b>VERY LOW</b>	

- Extent of Panorama
- Approximate Extent of Project

### Existing Landscape Character Description:

This viewpoint is located at a rest area along the Golden Highway, facing east toward the Project.

The surrounding land is characterised by road infrastructure, with roadside vegetation fragmenting views of cleared pastured in the middle-ground.

Rising topography and dense roadside vegetation to the east contains views. Views to the north are filtered by roadside vegetation.

The visual sensitivity of this viewpoint has been rated as **LOW**.

### Potential Visual Impact:

Due to the distance from this viewpoint and intervening screening elements in the foreground, including established vegetation - the Project will be screened, with no opportunity for visibility from this location. This results in a **VERY LOW** visual magnitude.

Combined with a **LOW** sensitivity, this leads to an overall **VERY LOW** visual impact.

Viewpoint:

# VP03 Rural Fire Service Station, Spring Ridge Road, Cobbora, NSW



Maximum Extent of Project

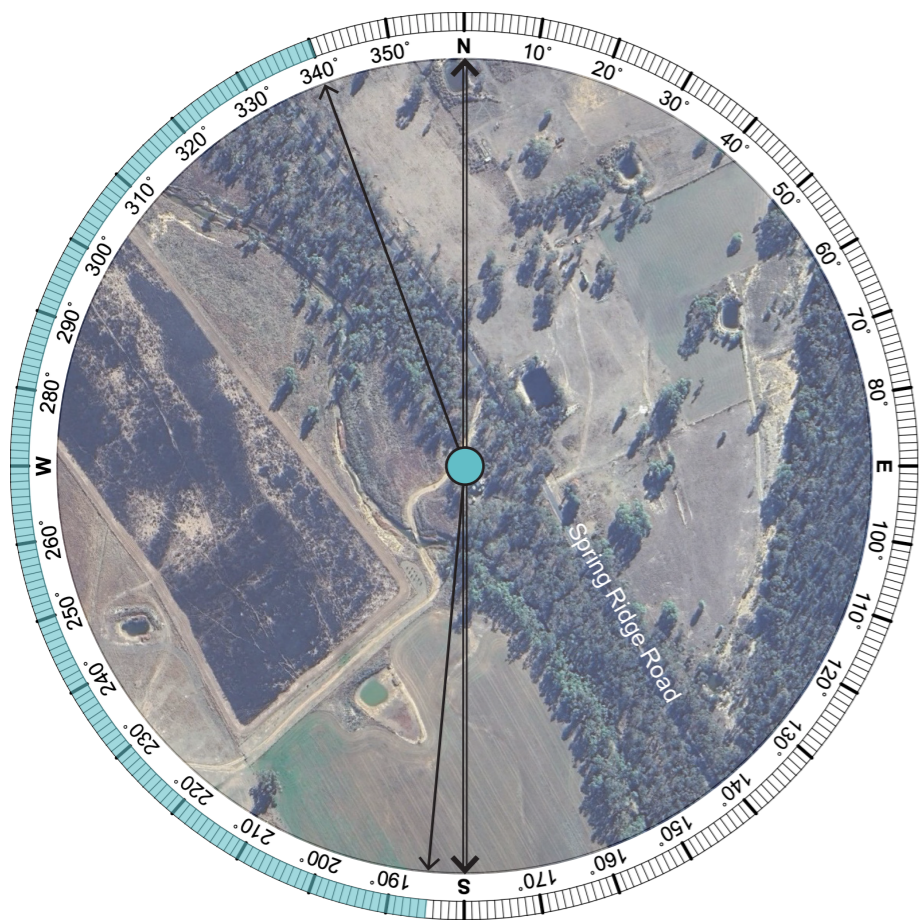

Aerial Source: Google Earth, 2023

**Viewpoint Summary:**

Location:	Elevation:
Rural Fire Service Station, Spring Ridge Road, Cobbora, NSW	396 m
Coordinates:	Distance to Project:
32°10'47.33"S 149°15'38.68"E	0.10 km
Viewing Direction:	
West	
Visual Sensitivity:	
LOW	
Visual Magnitude:	
HIGH	
Visual Impact:	
<b>LOW - MODERATE</b>	

- Extent of Panorama
- Approximate Extent of Project

**Existing Landscape Character Description:**

This viewpoint was taken from the Rural Fire Service Station, just off Spring Ridge Road, facing west toward the Project.

The surrounding land is characterised by undulating topography cleared for agricultural use, with dense native vegetation bordering Spring Ridge Road.

Cleared land to the west provides open views of the nearby pastures, with roadside vegetation screening views to the north and filtering views to the south.

The predominant landuse in the area is a combination of native woodland and pastures, utilised for grazing, and cropping

The visual sensitivity of this viewpoint has been rated as **LOW**.

**Potential Visual Impact:**

From this viewpoint, the Project will be a new visual element in the landscape.

The magnitude of the viewpoint is assessed as **HIGH**, reflecting the alteration of the landscape character in the immediate area. The existing landscape character is already highly modified, resulting in an overall Low scenic quality.

The combined results lead to a **LOW-MODERATE** visual impact overall.

Viewpoint:

# VP04 Spring Ridge Road, Cobbora, NSW



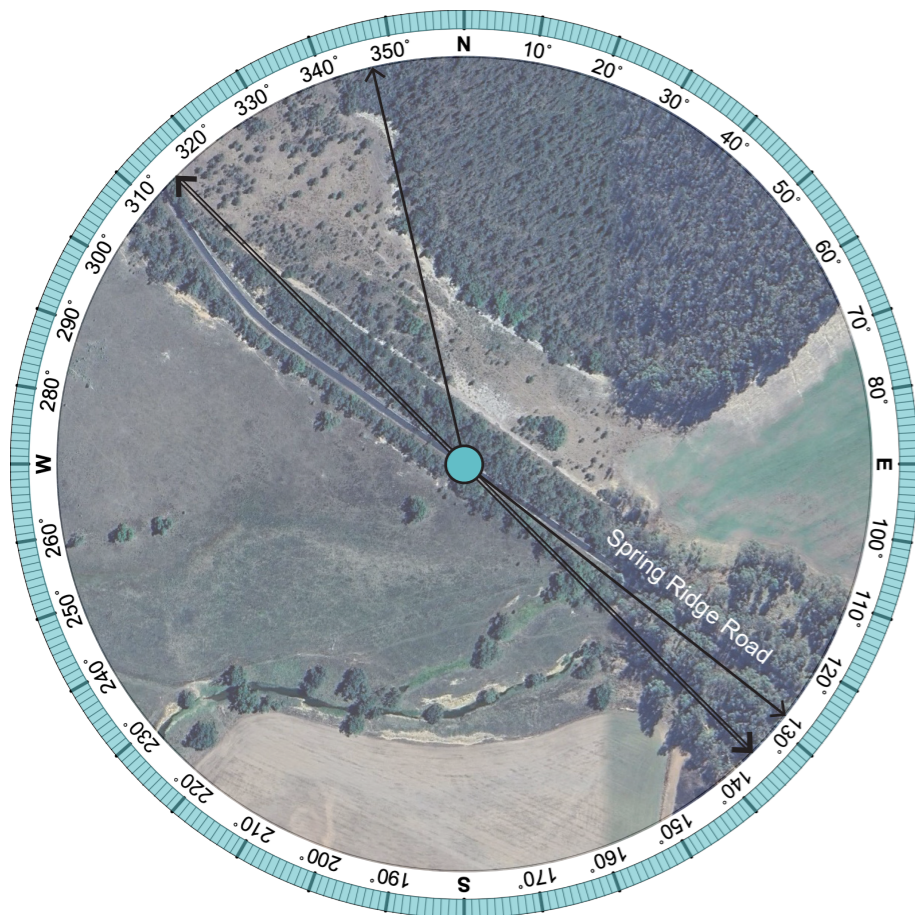

Maximum Extent of Project



Aerial Source: Google Earth, 2023

### Viewpoint Summary:

Location:	Elevation:
Spring Ridge Road, Cobbora, NSW	392 m
Coordinates:	Distance to Project:
32° 9'55.25"S 149° 14'42.09"E	0.02 km
Viewing Direction: Southwest	
Visual Sensitivity: VERY LOW	
Visual Magnitude: LOW	
Visual Impact: <b>VERY LOW</b>	

-  Extent of Panorama
-  Approximate Extent of Project

### Existing Landscape Character Description:

This viewpoint is located along Spring Ridge Road, a low-use sealed road, facing southwest toward the Project.

The surrounding landscape is characterised by roadside vegetation in the foreground, fragmenting views of cleared pastures in the middle-ground of the view.

The surrounding landuse is a mix of native woodland and pastures, utilised for grazing.

The visual sensitivity of this viewpoint has been rated as **VERY LOW**.

### Potential Visual Impact:

The Project will be a new visual element in the landscape to the southwest, in the background of this view. However, the visibility of the Project will be filtered due to the established roadside vegetation.

The introduction of the Project does not alter the existing landscape features, which primarily consist of cleared agricultural pastures and roadside vegetation that define this view.

The visual magnitude of change is **LOW**, resulting in a **VERY LOW** visual impact.

Viewpoint:

# VP05 Spring Ridge Road, Cobbora, NSW



Maximum Extent of Project

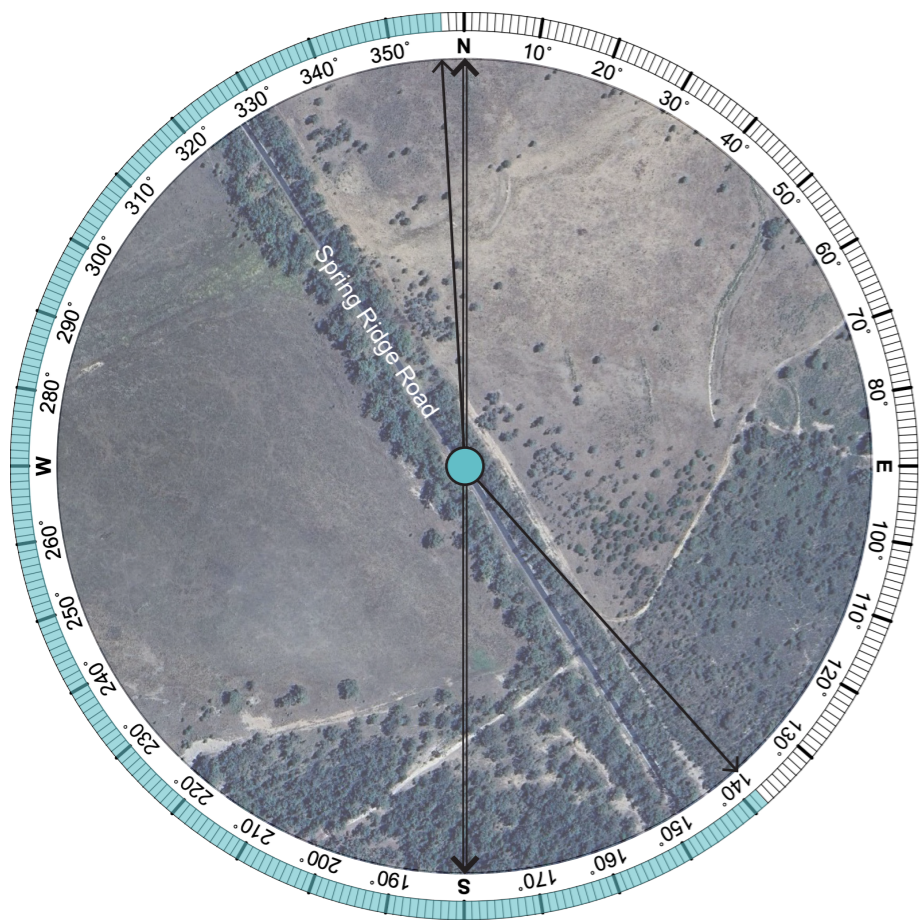

Aerial Source: Google Earth, 2023

**Viewpoint Summary:**

Location:	Elevation:
Spring Ridge Road, Cobbora, NSW	399 m
Coordinates:	Distance to Project:
32° 9'6.39"S 149°14'0.51"E	0.02 km
Viewing Direction:	
West	
Visual Sensitivity:	
VERY LOW	
Visual Magnitude:	
LOW	
Visual Impact:	
<b>VERY LOW</b>	

- Extent of Panorama
- Approximate Extent of Project

**Existing Landscape Character Description:**

This viewpoint is located along Spring Ridge Road, a low-use sealed road, facing southwest toward the Project.

The surrounding landscape is characterised by roadside vegetation in the foreground, filtering and screening views of cleared pastures in the background of the view.

The surrounding landuse is a mix of native woodland and pastures, utilised for grazing.

The visual sensitivity of this viewpoint has been rated as **VERY LOW**.

**Potential Visual Impact:**

The Project will be a new visual element in the landscape to the northwest, in the background of this view.

However, the visual magnitude of change is assessed as **LOW** as intervening vegetation in the foreground will limit the visibility of the Project.

The combined results lead to a **VERY LOW** visual impact overall.

Viewpoint:

# VP06 Spring Ridge Road, Cobbora, NSW



Extent of Potential Visibility

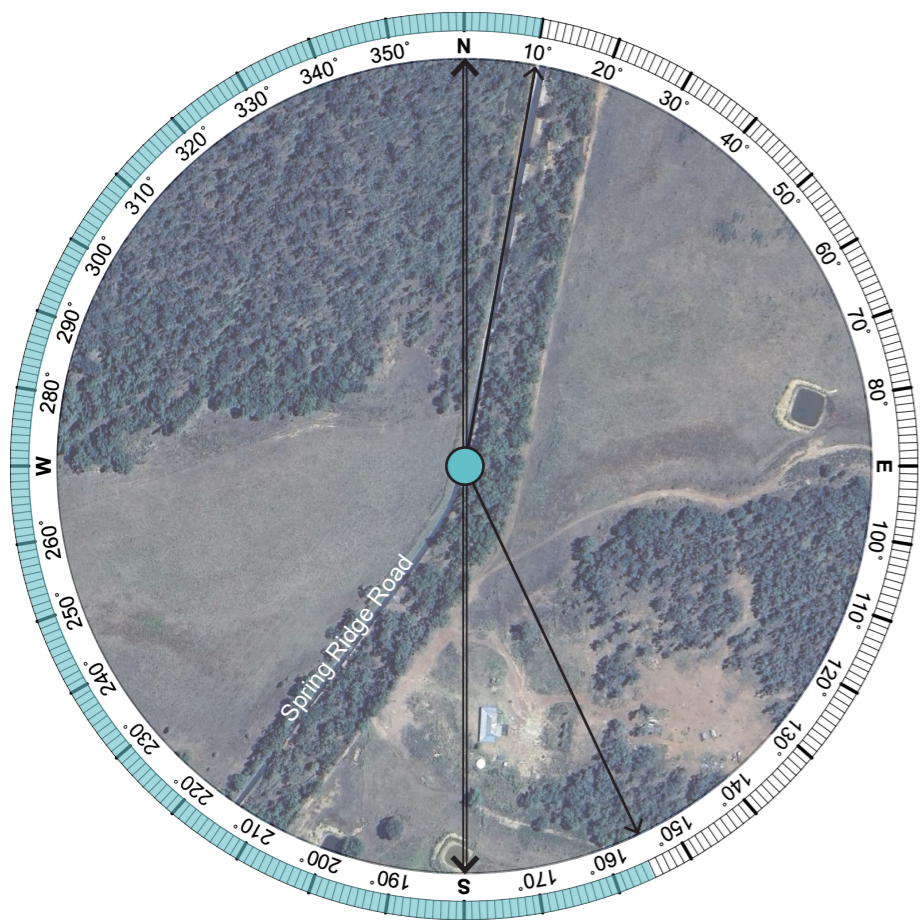

Aerial Source: Google Earth, 2023

**Viewpoint Summary:**

Location:	Elevation:
Spring Ridge Road, Cobbora, NSW	390 m
Coordinates:	Distance to Project:
32° 7'28.96"S 149°13'47.12"E	0.02 km
Viewing Direction:	
West	
Visual Sensitivity:	
VERY LOW	
Visual Magnitude:	
MODERATE	
Visual Impact:	
<b>LOW</b>	



**Existing Landscape Character Description:**

This viewpoint is located along Spring Ridge Road, a low-use sealed road, facing west toward the Project.

The surrounding landscape is characterised gently undulating farmland cleared for grazing, with scattered pockets of native vegetation visible in the background.

Roadside vegetation screens views to the north and south. To the immediate west the land is cleared, with young native vegetation filtering views of the adjacent pastures.

The surrounding landuse is a mix of native woodland and pastures, utilised for grazing.

The visual sensitivity of this viewpoint has been rated as **VERY LOW**.

**Potential Visual Impact:**

From this road, the Project will be a new visual element in the landscape to the immediate west.

The Magnitude of the viewpoint is assessed as **MODERATE**, reflecting the alteration of the landscape character in the immediate area. It is important to note that this viewpoint is situated along a low-use sealed road, characterised by low sensitivity and a modified landscape in the foreground, resulting in an overall low scenic quality.

The combined results lead to a **LOW** visual impact overall.

Viewpoint:

# VP07 Intersection of Golden Highway and Sandy Creek Road, Cobbora, NSW



Maximum Extent of Project

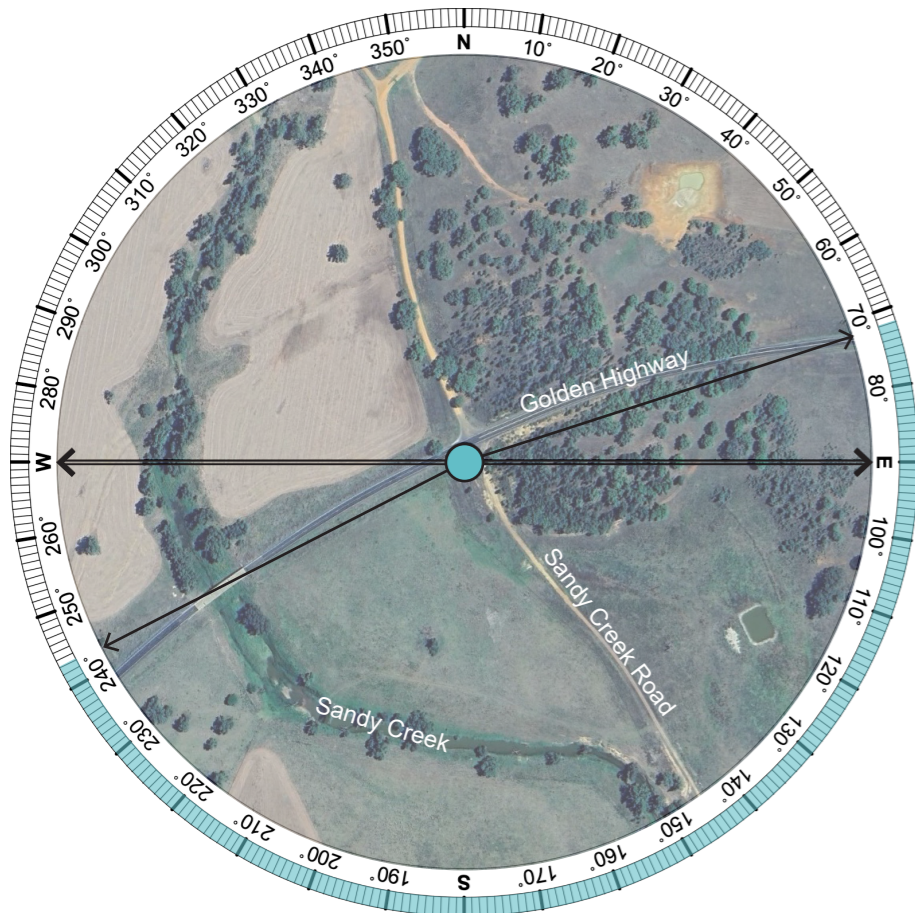

Aerial Source: Google Earth, 2023

### Viewpoint Summary:

Location:	Elevation:
Intersection of Golden Highway and Sandy Creek Road, Cobbora, NSW	353 m
Coordinates:	Distance to Project:
32° 6'25.46"S 149°11'46.11"E	0.01 km

Viewing Direction:  
South

Visual Sensitivity:  
VERY LOW

Visual Magnitude:  
LOW

Visual Impact:  
**VERY LOW**

- Extent of Panorama
- Approximate Extent of Project

### Existing Landscape Character Description:

This viewpoint is located at the intersection of the Golden Highway and Spring Ridge Road, facing south toward the Project.

The surrounding land is characterised by gently undulating farmland cleared for grazing, with pockets of native vegetation visible to the east and in the background.

Vegetation in the foreground screens views to the east and fragments views of the open pastures to the south. Scattered riparian vegetation associated with Sandy Creek, is visible in the foreground to the south.

The surrounding landuse is a mix of native woodland, modified pastures and cropping. Highway infrastructure is visible to the west.

The visual sensitivity of this viewpoint has been rated as **VERY LOW**.

### Potential Visual Impact:

The Project will be a new visual element in the landscape to the southwest, in the background of this view. However, the visibility of the Project will be filtered due to the combination of established roadside vegetation and scattered riparian vegetation along Sandy Creek.

The introduction of the Project does not alter the existing landscape features, which primarily consist of cleared agricultural pastures and roadside vegetation that define this view.

The visual magnitude of change is **LOW**, resulting in a **VERY LOW** visual impact.

Viewpoint:

# VP08 Sweeneys Lane, Elong Elong, NSW



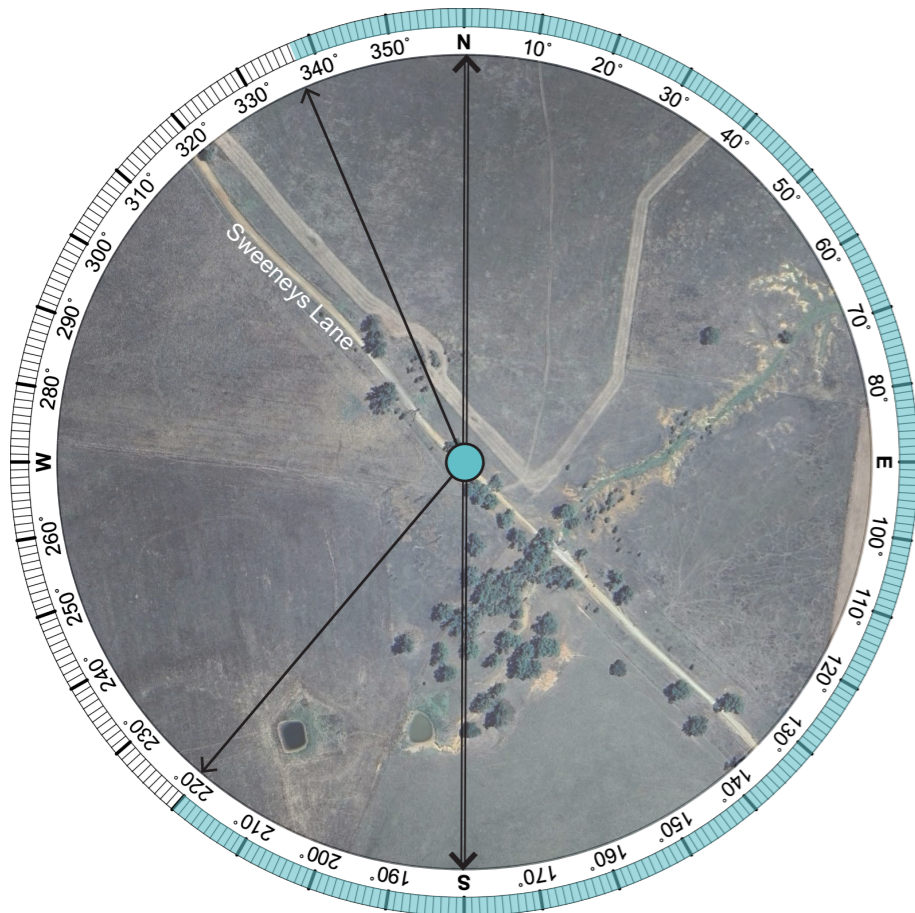

Maximum Extent of Project



Aerial Source: Google Earth, 2023

### Viewpoint Summary:

Location:	Elevation:
Sweeneys Lane, Elong Elong, NSW	375 m
Coordinates:	Distance to Project:
32° 8'51.84"S 149°11'36.20"E	0.09 km
Viewing Direction:	
East	
Visual Sensitivity:	
VERY LOW	
Visual Magnitude:	
MODERATE	
Visual Impact:	
<b>LOW</b>	

-  Extent of Panorama
-  Approximate Extent of Project

### Existing Landscape Character Description:

This viewpoint is located along the unsealed Sweeneys Lane, facing east toward the Project.

The surrounding land is characterised by undulating topography, cleared for pastoral use, with small pockets of native vegetation visible in the background.

Scattered roadside vegetation screens views to the southeast. To the immediate east the land is cleared, providing open views of the adjacent pastures.

The surrounding landuse is a mix of native woodland and pastures, utilised for grazing.

The visual sensitivity of this viewpoint has been rated as **VERY LOW**.

### Potential Visual Impact:

The Project will be a new visual element in the landscape, visible in the background of this view.

The magnitude of the viewpoint is assessed as MODERATE, reflecting the alteration of landscape character in the immediate area. It is important to note that this viewpoint is situated along a low-use unsealed road, characterised by low sensitivity and a modified landscape in the foreground, resulting in an overall low scenic quality.

The combined results lead to a **LOW** visual impact overall.

Viewpoint:

# VP09 Dapper Road, Dunedoo, NSW



Dapper Road

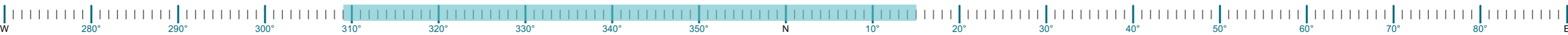

Maximum Extent of Project

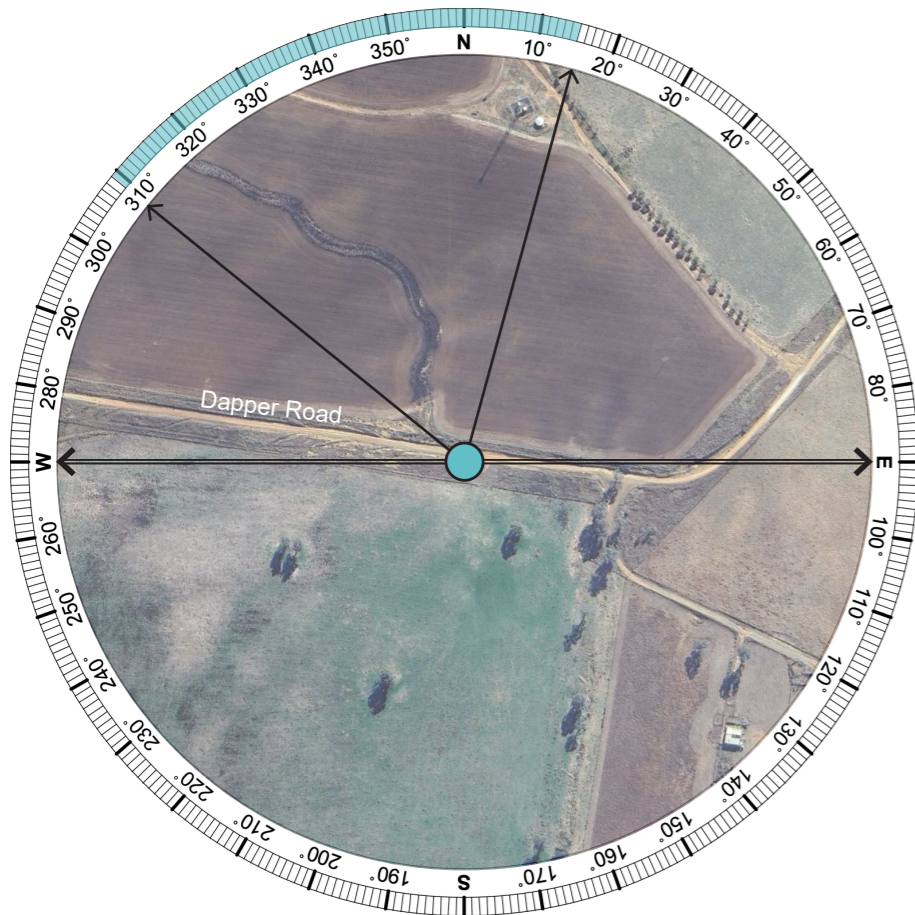

Aerial Source: Google Earth, 2023

### Viewpoint Summary:

Location:	Elevation:
Dapper Road, Dunedoo, NSW	445 m
Coordinates:	Distance to Project:
32°12'30.28"S 149°15'5.41"E	1.81 km
Viewing Direction:	
North	
Visual Sensitivity:	
VERY LOW	
Visual Magnitude:	
LOW	
Visual Impact:	
<b>VERY LOW</b>	

- Extent of Panorama
- Approximate Extent of Project

### Existing Landscape Character Description:

This viewpoint is located along the unsealed Dapper Road, facing north toward the Project.

The surrounding land is characterised by undulating topography, cleared for cropping and pastoral use.

The land rises to a highpoint in the northeast, sloping down to the west to reveal open views of the surrounding farmland.

The surrounding land is utilised for agriculture, with a mix of cropping and grazing pastures.

The visual sensitivity of this viewpoint has been rated as **VERY LOW**.

### Potential Visual Impact:

The Project will be a new non-dominant visual element in the landscape to the northeast, visible as part of the far background of this view. However, a portion of the Project will be screened by rising topography.

The introduction of the Project does not alter the existing landscape features, which primarily consist of the cleared agricultural pastures that define this view.

The visual magnitude of change is **LOW**, resulting in a **VERY LOW** visual impact.

Viewpoint:

# VP10 Dapper Road, Dunedoo, NSW



Dapper Road



Maximum Extent of Project

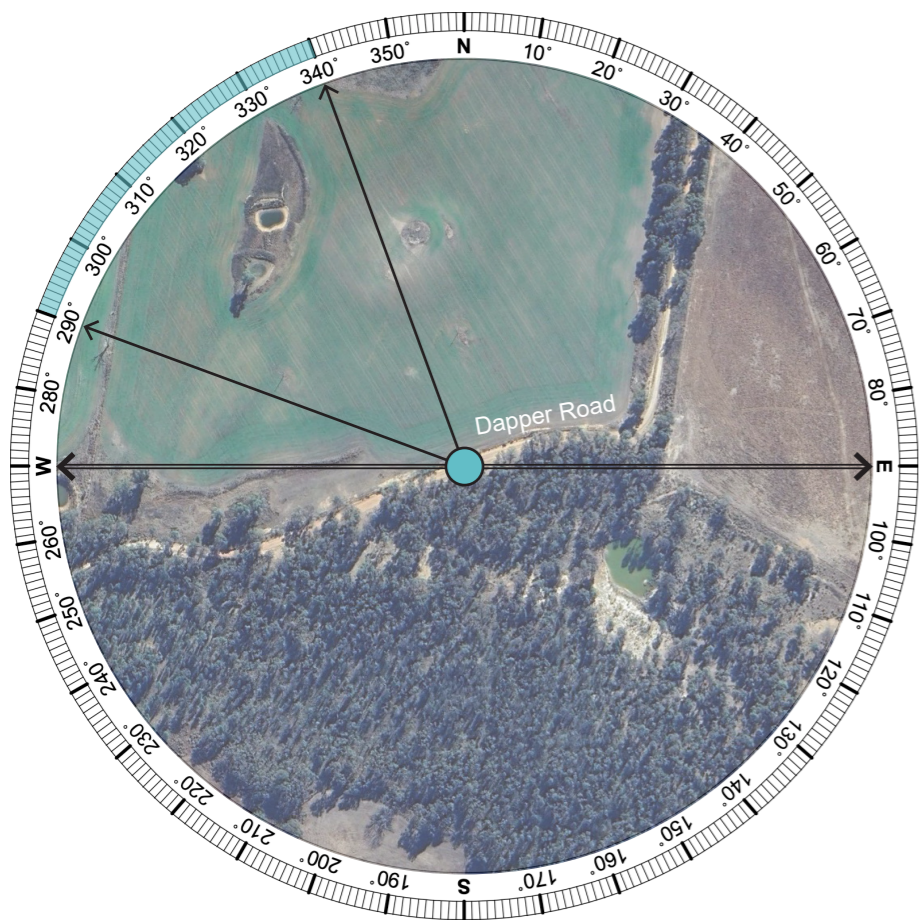

Aerial Source: Google Earth, 2023

**Viewpoint Summary:**

Location:	Elevation:
Dapper Road, Dunedoo, NSW	420 m
Coordinates:	Distance to Project:
32°11'52.88"S 149°16'4.60"E	1.7 km
Viewing Direction:	
Northwest	
Visual Sensitivity:	
VERY LOW	
Visual Magnitude:	
LOW	
Visual Impact:	
<b>VERY LOW</b>	

**Existing Landscape Character Description:**

This viewpoint is located along the unsealed Dapper Road, facing north toward the Project.

The surrounding land is characterised by gently undulating topography, cleared for pastoral use, with small pockets of native vegetation visible in the background. Vegetated hills are visible in the background of the view.

Scattered roadside vegetation screens views to the east. To the immediate north the land is cleared, providing open views of the adjacent pastures.

The surrounding land is utilised for agriculture, with a mix of cropping and grazing pastures.

The visual sensitivity of this viewpoint has been rated as **VERY LOW**.

**Potential Visual Impact:**

The Project will be a new non-dominant visual element in the landscape to the far northeast, visible as part of the background. However, intervening elements including scattered vegetation in the middleground will likely filter views of the Project.

The introduction of the Project does not alter the existing landscape features, which primarily consist of the cleared agricultural pastures that define this view.

The visual magnitude of change is **LOW**, resulting in a **VERY LOW** visual impact.

Viewpoint:

# VP11 Dapper Road, Dunedoo, NSW



Dapper Road

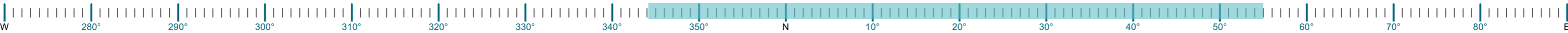

Maximum Extent of Project

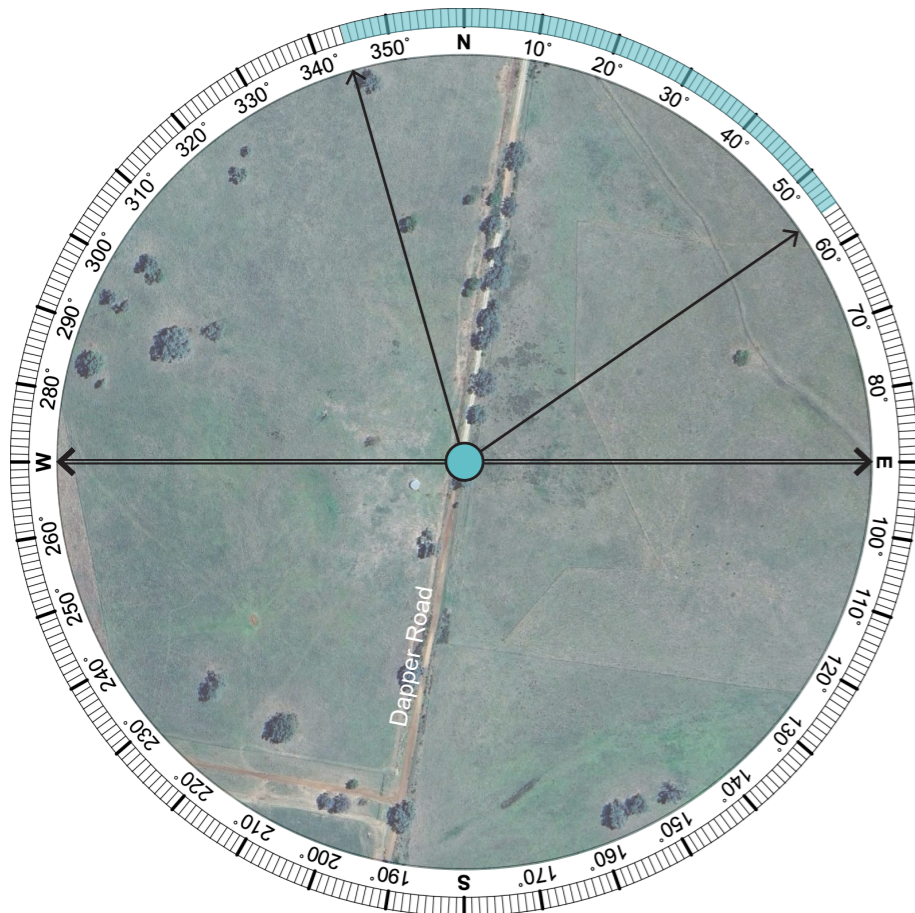

Aerial Source: Google Earth, 2023

### Viewpoint Summary:

Location:	Elevation:
Dapper Road, Dunedoo, NSW	457 m
Coordinates:	Distance to Project:
32°12'59.43"S 149°12'10.59"E	3.76 km
Viewing Direction:	
North	
Visual Sensitivity:	
VERY LOW	
Visual Magnitude:	
LOW	
Visual Impact:	
<b>VERY LOW</b>	

- Extent of Panorama
- Approximate Extent of Project

### Existing Landscape Character Description:

This viewpoint is located along the unsealed Dapper Road, facing north toward the Project.

The surrounding land is characterised by undulating topography, cleared for pastoral use, with native vegetation scattered alongside roads and though pastures. Vegetated hills are visible in the background of the view.

Roadside vegetation screens views to the north.

To the immediate northeast and northwest the land is cleared, providing open views of the adjacent pastures.

The surrounding land is utilised for agriculture, with a mix of cropping and grazing pastures.

The visual sensitivity of this viewpoint has been rated as **VERY LOW**.

### Potential Visual Impact:

The Project will be a new non-dominant visual element in the landscape to the northeast, visible as part of the far background of this view.

The introduction of the Project does not alter the existing landscape features, which primarily consist of the cleared agricultural pastures that define this view.

The visual magnitude of change is **LOW**, resulting in a **VERY LOW** visual impact.

Viewpoint:

# VP12 Dapper Road, Dunedoo, NSW



Dapper Road

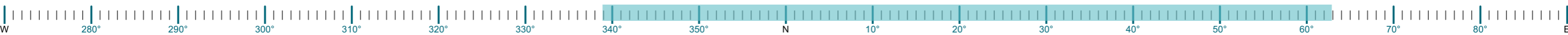

Maximum Extent of Project

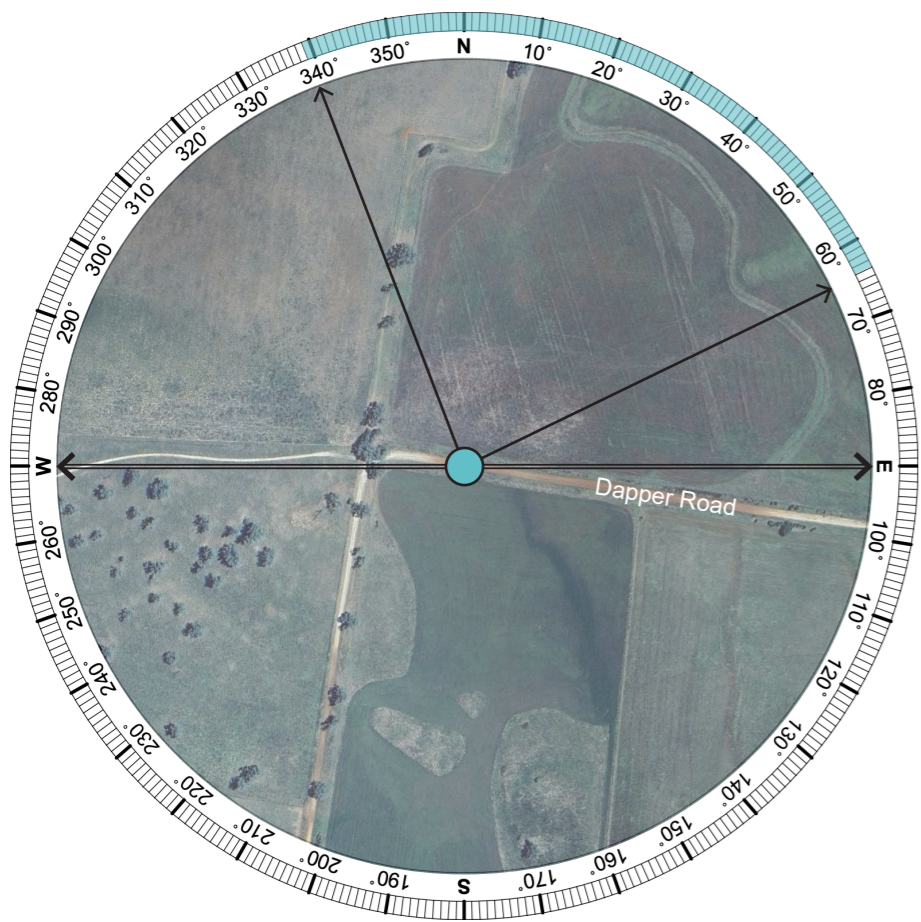

Aerial Source: Google Earth, 2023

**Viewpoint Summary:**

Location:	Elevation:
Dapper Road, Dunedoo, NSW	424 m
Coordinates:	Distance to Project:
32°12'28.22"S 149°12'19.18"E	2.89 km
Viewing Direction:	
North	
Visual Sensitivity:	
VERY LOW	
Visual Magnitude:	
LOW	
Visual Impact:	
<b>VERY LOW</b>	

**Existing Landscape Character Description:**

This viewpoint is located along the unsealed Dapper Road, facing north toward the Project.

The surrounding land is characterised by gently undulating topography, cleared for pastoral use, with trees scattered alongside roads and through pastures.

To the immediate north the land is cleared, providing open views of the adjacent pastures. In the background, pockets of vegetation filter views to the far northeast.

The surrounding land is utilised for agriculture, with a mix of cropping and grazing pastures.

The visual sensitivity of this viewpoint has been rated as **VERY LOW**.

**Potential Visual Impact:**

The Project will be a new non-dominant visual element in the landscape to the northeast, visible as part of the far background of this view. A large portion of the Project to the northeast will be screened or filtered due to intervening visual elements including scattered vegetation in the background.

The introduction of the Project does not alter the existing landscape features, which primarily consist of the cleared agricultural pastures that define this view.

The visual magnitude of change is **LOW**, resulting in a **VERY LOW** visual impact.

Viewpoint:

# VP13 Golden Highway Rest Area, Cobbora, NSW



Maximum Extent of Project

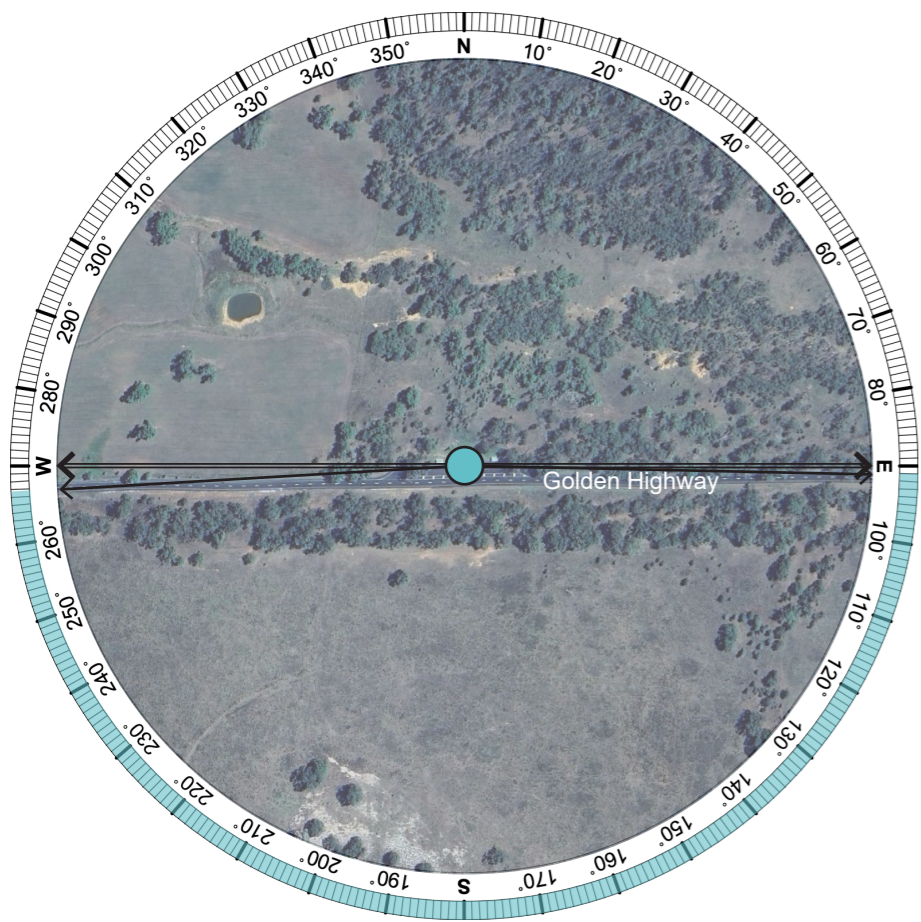

Aerial Source: Google Earth, 2023

### Viewpoint Summary:

Location:	Elevation:
Golden Highway Rest Area, Cobbora, NSW	372 m
Coordinates:	Distance to Project:
32° 6'21.24"S 149°12'37.50"E	0.05 km
Viewing Direction:	
South	
Visual Sensitivity:	
LOW	
Visual Magnitude:	
MODERATE	
Visual Impact:	
<b>LOW-MODERATE</b>	

- Extent of Panorama
- Approximate Extent of Project

### Existing Landscape Character Description:

This viewpoint is located at a rest area along the Golden Highway, facing south toward the Project.

The surrounding land is characterised by road infrastructure, with roadside vegetation filtering or screening views of cleared pastures in the background.

Rising topography and roadside vegetation screens views to the east and west and fragments views to the south.

The surrounding landuse is a mix of native woodland, modified pastures and cropping. Highway infrastructure is a prominent feature of this view.

The visual sensitivity of this viewpoint has been rated as **LOW**.

### Potential Visual Impact:

The Project will be a new dominant visual element in the landscape to the south. However, the visibility of the Project will be fragmented or screened due to the established roadside vegetation.

The Magnitude of the viewpoint is assessed as MODERATE, reflecting the alteration of the landscape character in the immediate area and close proximity to the Project. It is important to note that this viewpoint is situated along a highway, characterised by low sensitivity and a modified landscape in the foreground, resulting in an overall low scenic quality.

The combined results lead to a LOW-MODERATE visual impact overall.



**moir**  
STUDIO

## COBBORA SOLAR FARM

Appendix B - Detailed Assessments (Wireframes & Photomontages)

# Cobbora Solar Farm

## Intermediate and Detailed Assessments (Wireframes & Photomontages)

### Prepared for

Pacific Partnerships Pty Limited

### Issue

E

### Date

29/05/2025

### Project Number

2490

Revision	Date	Author	Checked	Comment
A	7/11/2024	CD	AR	Detailed Assessments
B	17/11/2024	CD	AR	Detailed Assessments
C	22/01/2025	CD		Detailed Assessments
D	19/03/2025	CD		Detailed Assessments
E	29/05/2025	CD		Final for Submission



Moir Landscape Architecture Pty Ltd  
(T/A Moir Studio)  
Studio 1, 88 Fern Street  
PO Box 111, Islington NSW 2296  
admin@moirla.com.au  
Ph.(02) 4965 3500  
www.moirstudio.com.au  
ACN: 097 558 908  
ABN: 48 097 558 908

# Contents

## 1 Intermediate Assessment (Wireframes)

PR\_1  
PR\_10  
PR\_12  
PR\_13  
PR\_14  
PR\_15  
PR\_2a (East)  
PR\_2b (West)  
PR\_22  
PR\_24  
PR\_3  
PR\_5a (East)  
PR\_5b (West)  
PR\_6a (North)  
PR\_6b (South)  
X05  
PR\_9  
PR\_16  
VP01  
VP03  
VP04  
VP05  
VP06  
VP07  
VP08a (East)  
VP08b (West)  
VP13

## 4 Detailed Assessment (Photomontages)

7 PR\_1  
9 PR\_2  
11 PR\_5  
13 PR\_6a (Northwest)  
15 PR\_6b (Southeast)  
17 X05  
19 VP03  
21 VP04  
23 VP06  
25 VP08  
27 VP13  
29  
31  
33  
35  
37  
39  
41  
43  
45  
47  
49  
51  
53  
55  
57  
59

## 61

64  
66  
68  
70  
72  
74  
76  
78  
80  
82  
84



# 1 Intermediate Assessment (Wireframes)

# Intermediate Assessment - Wireframe Locations

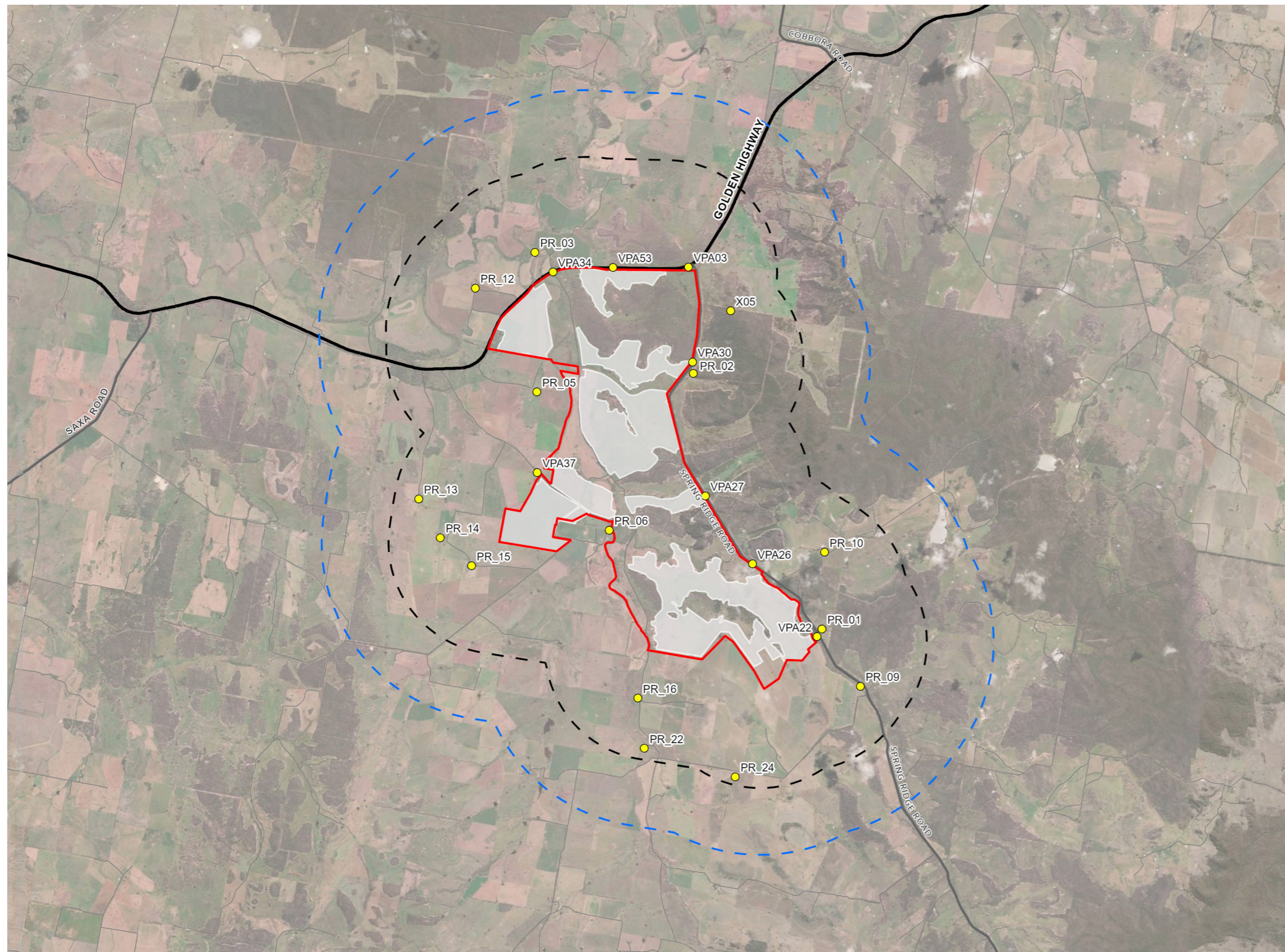

## LEGEND

- Project Boundary
- PV Array Area for Assessment
- Public & Railway Receptors Study Area (2.5 km from Solar Array Area)
- Sensitive Private Receptors Study Area (4.0 km from Solar Array Area)
- Highway
- Roads
- Unsealed Roads
- Wireframe Locations

**Figure 01 – Wireframe Locations**  
Basemap Source: ESRI, 2024

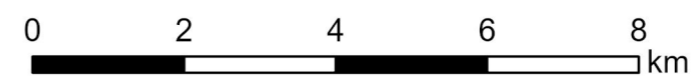

# Intermediate Assessment Methodology (Wireframes)

## Phase 1 - Detailed Assessment (Wireframes)

The purpose of preparing wireframes is to determine the visual magnitude of a Project more accurately. This involves using 3D modelling, which can account for many factors that influence magnitude, including intervening topography, the different distances at which the PV Array will be visible, and spacing between panels. If the result of the wireframe assessment indicates that a moderate or high impact is likely, a site inspection and detailed assessment using photomontages are undertaken from these locations.

\*Note that the wireframe assessment is based off a worst case scenario, modelled to the Project Boundary extents.

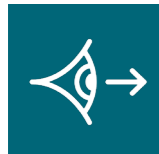

### Step 1 - Determine Visual Sensitivity

The visual sensitivity is determined by identifying the sensitivity of each viewpoint and receiver and categorising the scenic quality of the area in view (refer to the LVIA for an assessment of the existing landscape character).

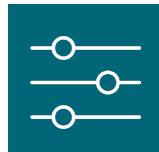

### Step 2 - Determine Visual Magnitude

Visual magnitude is determined by analysing the volume of the field of view that a project would occupy. This can be determined by splitting the wire frame diagram into a grid comprising cells 1 degree high and 10 degrees wide and counting the number of cells that would be occupied by a Project. As per the Guideline, 'a cell is unoccupied if elements of the project, including solar panels, battery energy systems, or other associated infrastructure do not occupy more than approximately 25% of a cell'. The cell count for the Wireframe Diagrams is based on a 2d assessment and does not consider existing screen factors such as vegetation or structures.

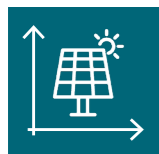

### Step 3 - Determine Visual Impact Rating

The overall visual impact rating of each viewpoint must be determined for each assessable viewpoint by combining the visual magnitude and visual sensitivity using the matrix adjacent.

Visual Magnitude (Number of Occupied Cells)	Visual Sensitivity			
	High	Moderate	Low	Very Low
Very High 37+	High	High	Moderate	Moderate
High 26 - 36	High	Moderate	Moderate	Low
Moderate 15 - 25	Moderate	Moderate	Low	Low
Low 8 - 14	Moderate	Low	Low	Very Low
Very Low 1 - 7	Low	Low	Very Low	Very Low

### Further Assessment Required:

Any viewpoint locations with a moderate or high visual impact will require a detailed assessment. (including a site inspection and photomontage)

Yes	No
-----	----

Dwelling/Public Viewpoint ID:

**PR\_1**

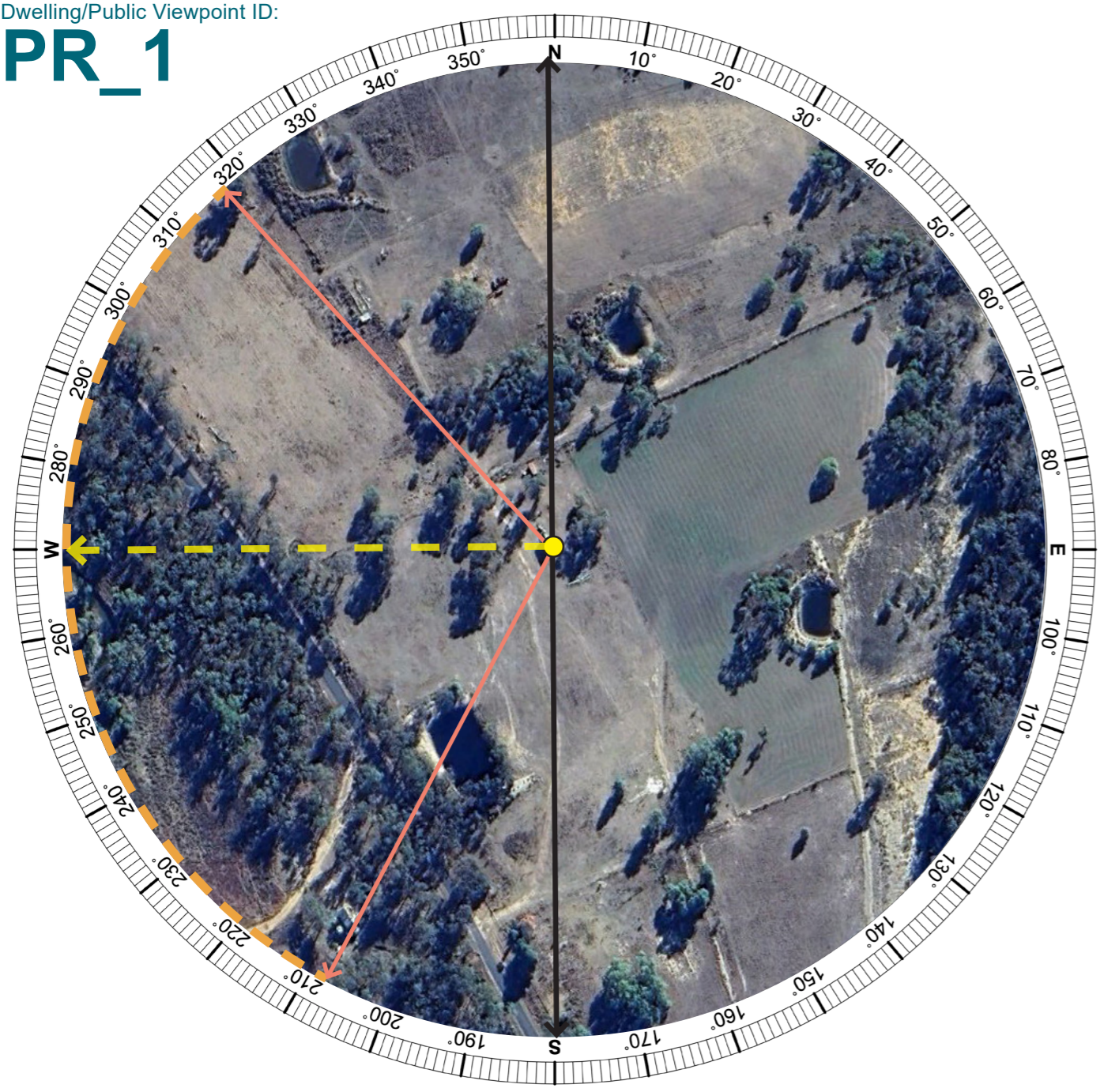

**LEGEND**

- Direction of potential visible Development Footprint (based on topography alone)
- - - Extent of potential visible Development Footprint (based on topography alone)
- Direction of the Wireframe
- ↔ Extent of Panorama
- Location of the viewpoint

Aerial Image - Wireframe Location (Aerial Image Source: Google Earth 2023)

**Residential Receptor PR\_1**

Receptor Assessment:									
Coordinates	Distance to development:	Viewpoint Type:	Receptor Sensitivity:	Scenic Quality:	Overall Sensitivity:	Occupied Cells:	Magnitude Rating:	Preliminary Visual Impact Rating:	Site Visit Required?
32°10'41.57"S 149°15'42.95"E	0.26 km	Residential Receptor	Moderate	Low	Moderate	20	Moderate	Moderate	<b>YES</b> / NO

**OCCUPIED CELL COUNT (TRANSMISSION LINES)**  
■ Occupied Cell (greater than 3 degrees height)  
A cell is unoccupied if the transmission lines do not occupy more than three vertical degrees of view or 3 vertical cells.

**OCCUPIED CELL COUNT (SOLAR FARM)**  
■ Occupied Cell (greater than 25%)  
A cell is unoccupied if elements of the project, including solar panels, battery energy systems, or other associated infrastructure do not occupy more than approximately 25% of a cell.

**Further Assessment Required:**

**Yes**  **No**

PR\_1  
Residential Receptor

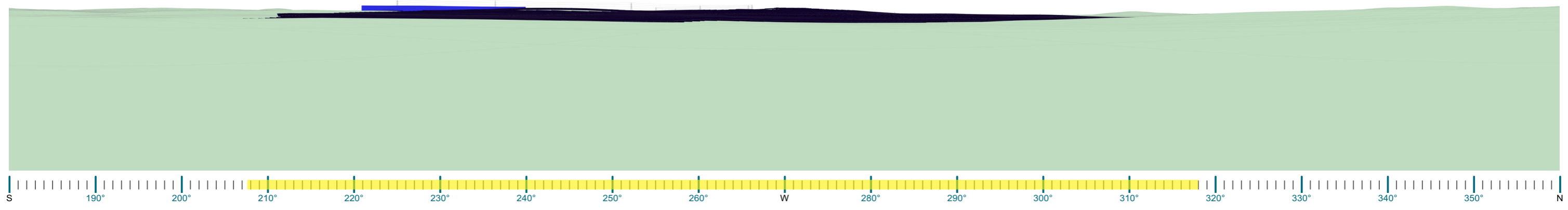

← Extent of potentially visible solar panels (based on topography alone) →

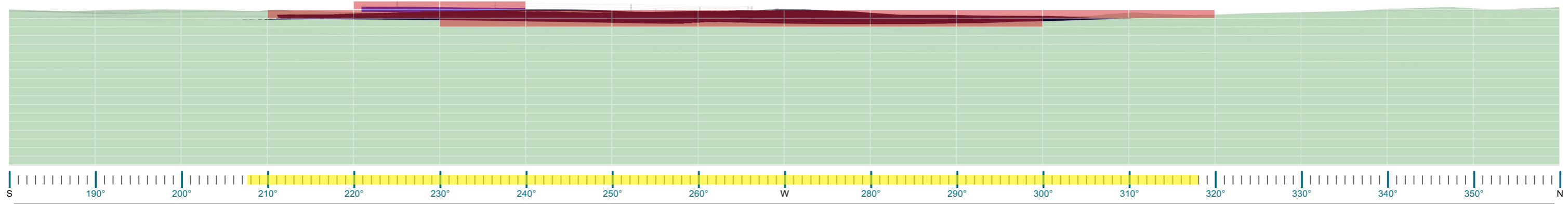
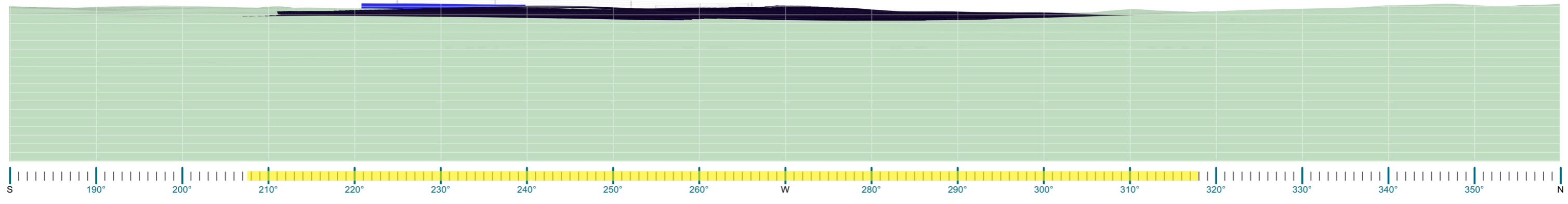

Dwelling/Public Viewpoint ID:  
**PR\_10**

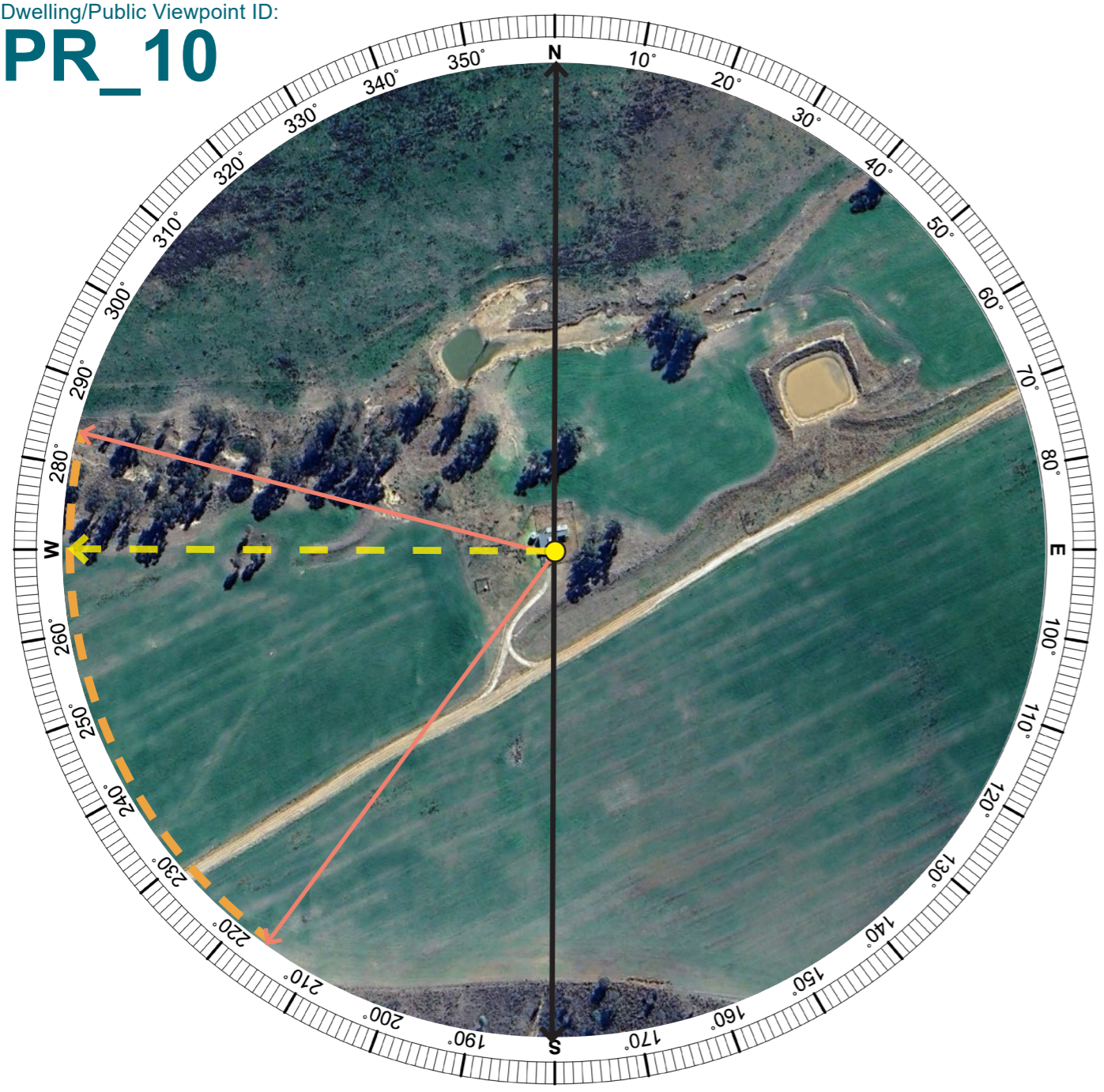

**LEGEND**

- Direction of potential visible Development Footprint (based on topography alone)
- Extent of potential visible Development Footprint (based on topography alone)
- Direction of the Wireframe
- Extent of Panorama
- Location of the viewpoint

Aerial Image - Wireframe Location (Aerial Image Source: Google Earth 2023)

**Residential Receptor PR\_10**

Receptor Assessment:									
Coordinates	Distance to development:	Viewpoint Type:	Receptor Sensitivity:	Scenic Quality:	Overall Sensitivity:	Occupied Cells:	Magnitude Rating:	Preliminary Visual Impact Rating:	Site Visit Required?
32° 9'45.66"S 149° 15'43.52"E	1.28 km	Residential Receptor	Moderate	Low	Moderate	4	Very Low	Low	YES / <b>NO</b>

**OCCUPIED CELL COUNT (TRANSMISSION LINES)**  
 Occupied Cell (greater than 3 degrees height)  
 A cell is unoccupied if the transmission lines do not occupy more than three vertical degrees of view or 3 vertical cells.

**OCCUPIED CELL COUNT (SOLAR FARM)**  
 Occupied Cell (greater than 25%)  
 A cell is unoccupied if elements of the project, including solar panels, battery energy systems, or other associated infrastructure do not occupy more than approximately 25% of a cell.

**Further Assessment Required:**

Yes  No

PR\_10  
Residential Receptor

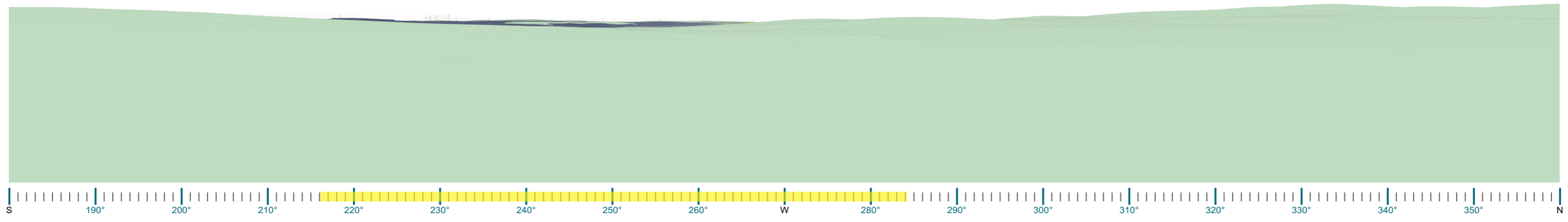

← Extent of potentially visible solar panels (based on topography alone) →

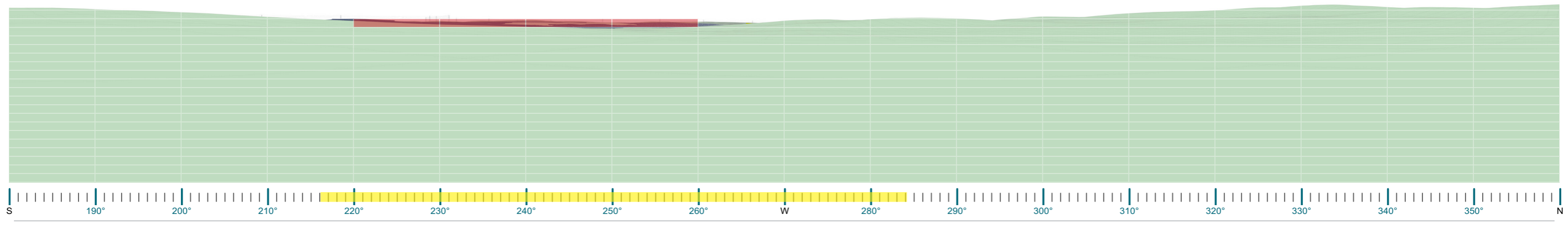
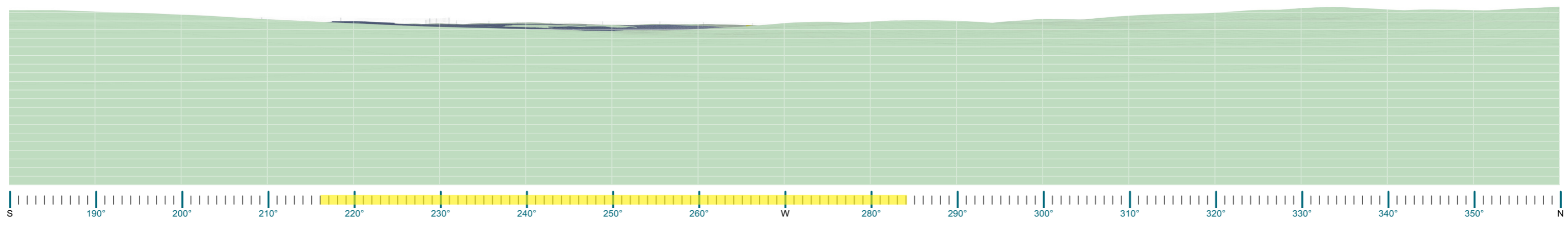

Dwelling/Public Viewpoint ID:  
**PR\_12**

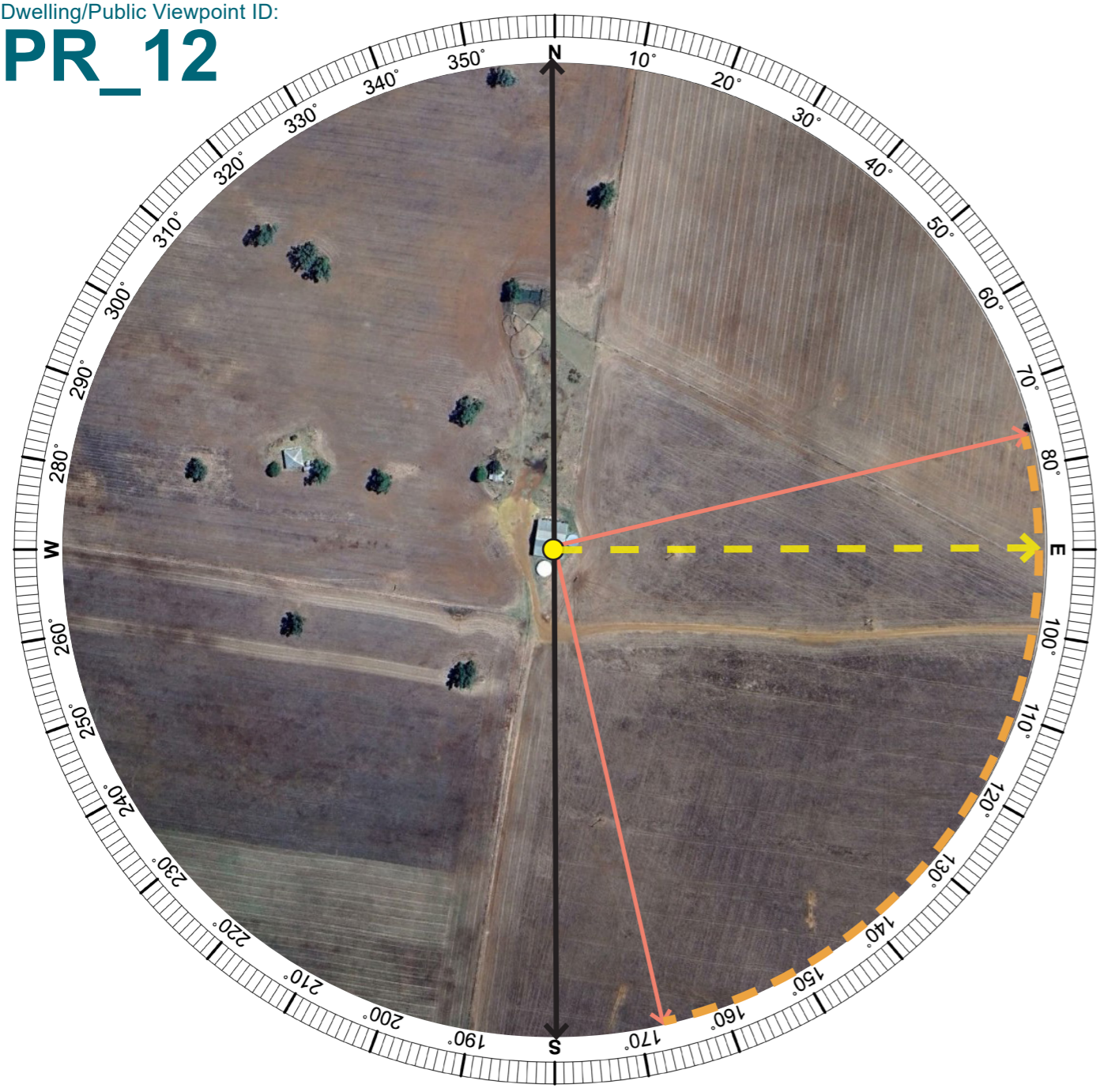

**LEGEND**

- Direction of potential visible Development Footprint (based on topography alone)
- - - Extent of potential visible Development Footprint (based on topography alone)
- Direction of the Wireframe
- ↔ Extent of Panorama
- Location of the viewpoint

Aerial Image - Wireframe Location (Aerial Image Source: Google Earth 2023)

**Residential Receptor PR\_12**

Receptor Assessment:									
Coordinates	Distance to development:	Viewpoint Type:	Receptor Sensitivity:	Scenic Quality:	Overall Sensitivity:	Occupied Cells:	Magnitude Rating:	Preliminary Visual Impact Rating:	Site Visit Required?
32° 6'38.34"S 149°10'39.95"E	0.92 km	Residential Receptor	Moderate	Low	Moderate	11	Low	Low	YES / <b>NO</b>

**OCCUPIED CELL COUNT (TRANSMISSION LINES)**  
■ Occupied Cell (greater than 3 degrees height)  
A cell is unoccupied if the transmission lines do not occupy more than three vertical degrees of view or 3 vertical cells.

**OCCUPIED CELL COUNT (SOLAR FARM)**  
■ Occupied Cell (greater than 25%)  
A cell is unoccupied if elements of the project, including solar panels, battery energy systems, or other associated infrastructure do not occupy more than approximately 25% of a cell.

**Further Assessment Required:**

Yes  No

PR\_12  
Residential Receptor

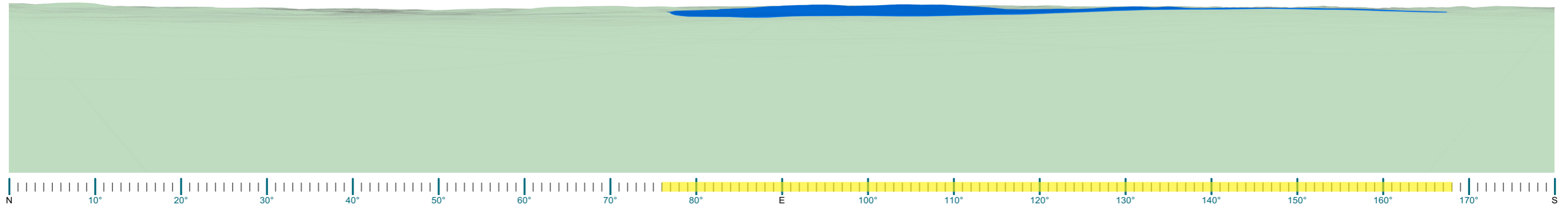

Extent of potentially visible solar panels (based on topography alone)

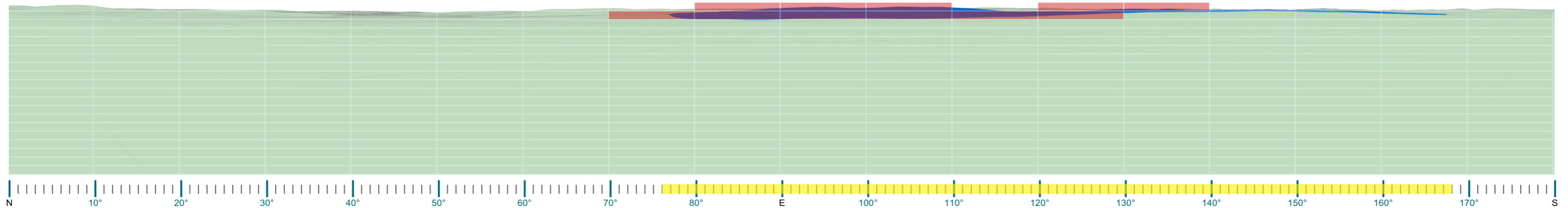
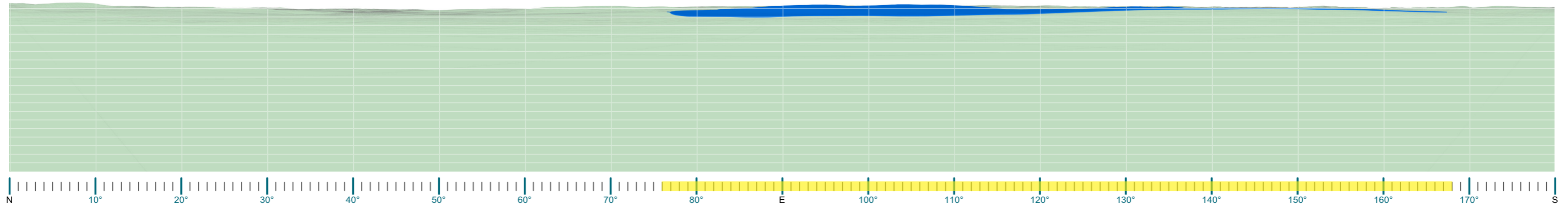

Dwelling/Public Viewpoint ID:  
**PR\_13**

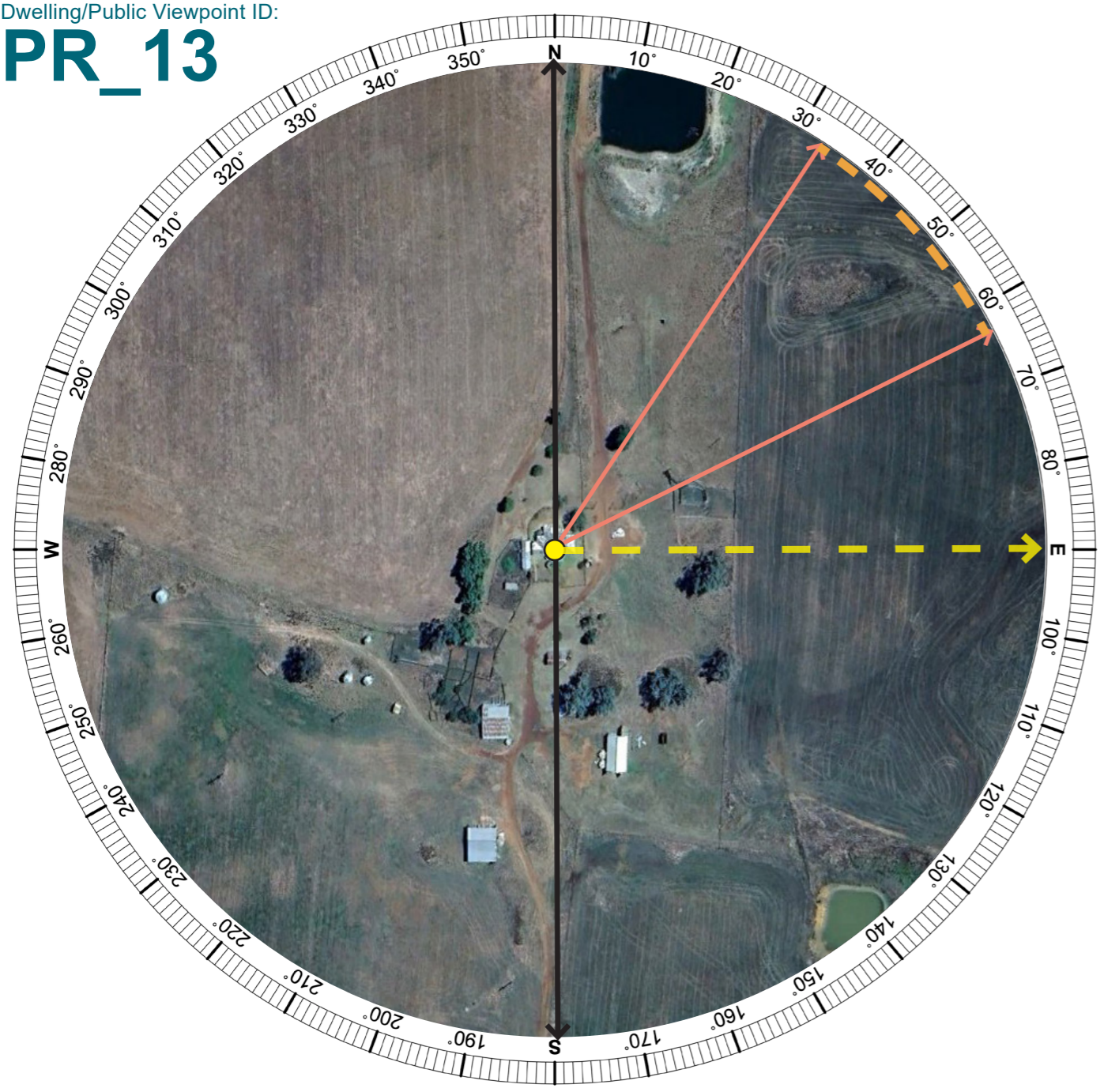

**LEGEND**

- Direction of potential visible Development Footprint (based on topography alone)
- Extent of potential visible Development Footprint (based on topography alone)
- Direction of the Wireframe
- Extent of Panorama
- Location of the viewpoint

Aerial Image - Wireframe Location (Aerial Image Source: Google Earth 2023)

**Residential Receptor PR\_13**

Receptor Assessment:									
Coordinates	Distance to development:	Viewpoint Type:	Receptor Sensitivity:	Scenic Quality:	Overall Sensitivity:	Occupied Cells:	Magnitude Rating:	Preliminary Visual Impact Rating:	Site Visit Required?
32° 9'12.86"S 149° 9'55.11"E	1.95 km	Residential Receptor	Moderate	Low	Moderate	3	Very Low	Low	YES / <b>NO</b>

**OCCUPIED CELL COUNT (TRANSMISSION LINES)**  
 Occupied Cell (greater than 3 degrees height)  
 A cell is unoccupied if the transmission lines do not occupy more than three vertical degrees of view or 3 vertical cells.

**OCCUPIED CELL COUNT (SOLAR FARM)**  
 Occupied Cell (greater than 25%)  
 A cell is unoccupied if elements of the project, including solar panels, battery energy systems, or other associated infrastructure do not occupy more than approximately 25% of a cell.

**Further Assessment Required:**

Yes  No

PR\_13  
Residential Receptor

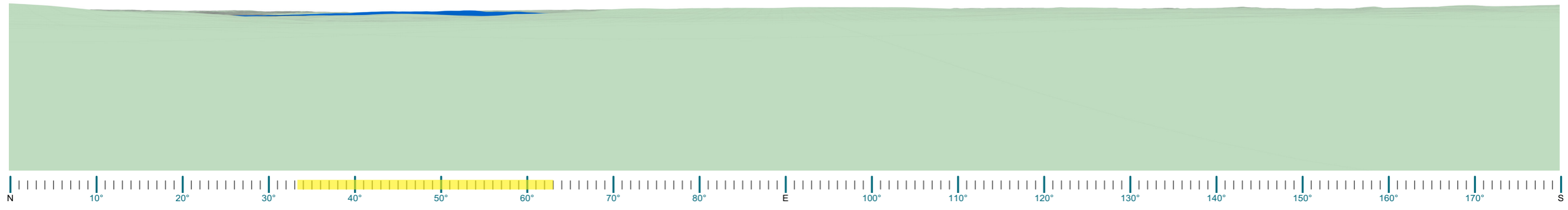

Extent of potentially visible solar panels  
(based on topography alone)

←—————→

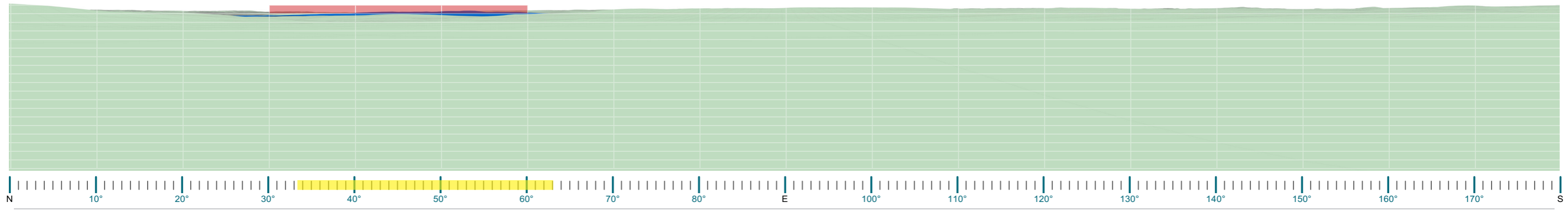
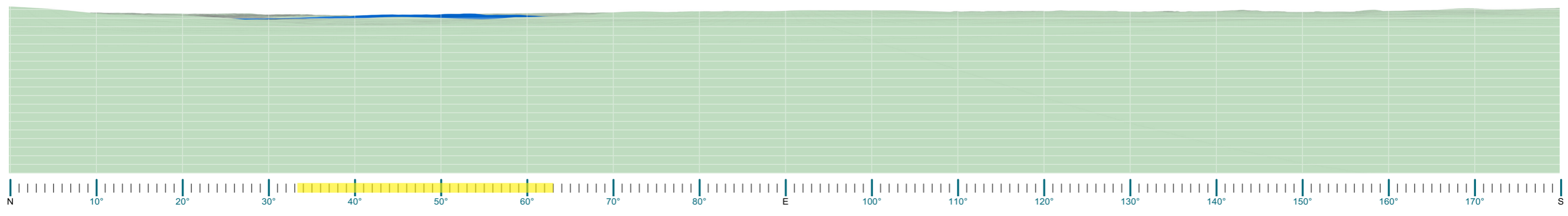

Dwelling/Public Viewpoint ID:  
**PR\_14**

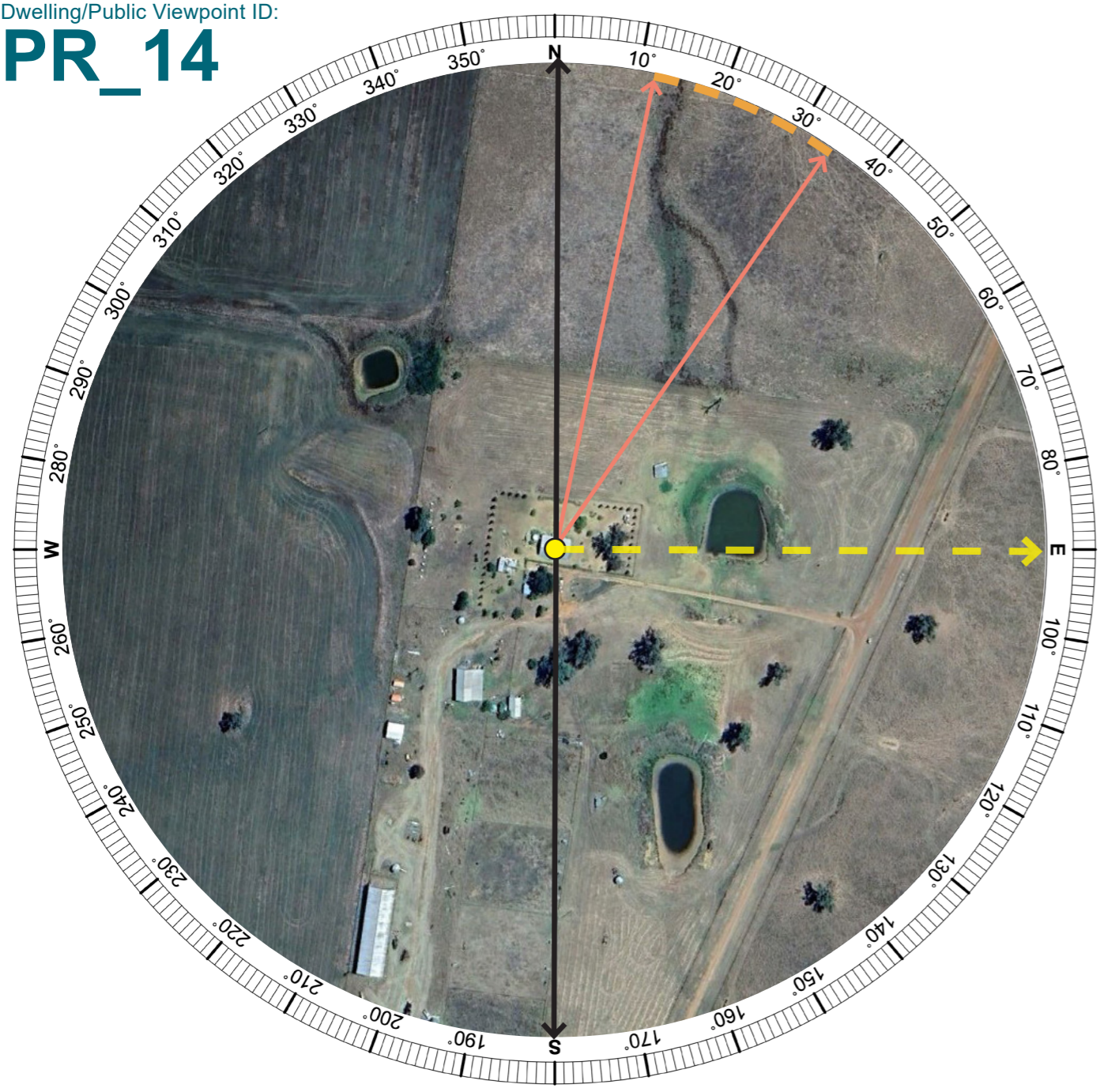

**LEGEND**

- Direction of potential visible Development Footprint (based on topography alone)
- - Extent of potential visible Development Footprint (based on topography alone)
- - → Direction of the Wireframe
- ↔ Extent of Panorama
- Location of the viewpoint

Aerial Image - Wireframe Location (Aerial Image Source: Google Earth 2023)

**Residential Receptor PR\_14**

Receptor Assessment:									
Coordinates	Distance to development:	Viewpoint Type:	Receptor Sensitivity:	Scenic Quality:	Overall Sensitivity:	Occupied Cells:	Magnitude Rating:	Preliminary Visual Impact Rating:	Site Visit Required?
32° 9'40.78"S 149°10'14.39"E	1.33 km	Residential Receptor	Moderate	Low	Moderate	0	Very Low	Low	YES / <b>NO</b>

**OCCUPIED CELL COUNT (TRANSMISSION LINES)**  
■ Occupied Cell (greater than 3 degrees height)  
 A cell is unoccupied if the transmission lines do not occupy more than three vertical degrees of view or 3 vertical cells.

**OCCUPIED CELL COUNT (SOLAR FARM)**  
■ Occupied Cell (greater than 25%)  
 A cell is unoccupied if elements of the project, including solar panels, battery energy systems, or other associated infrastructure do not occupy more than approximately 25% of a cell.

**Further Assessment Required:**

Yes  No

PR\_14  
Residential Receptor

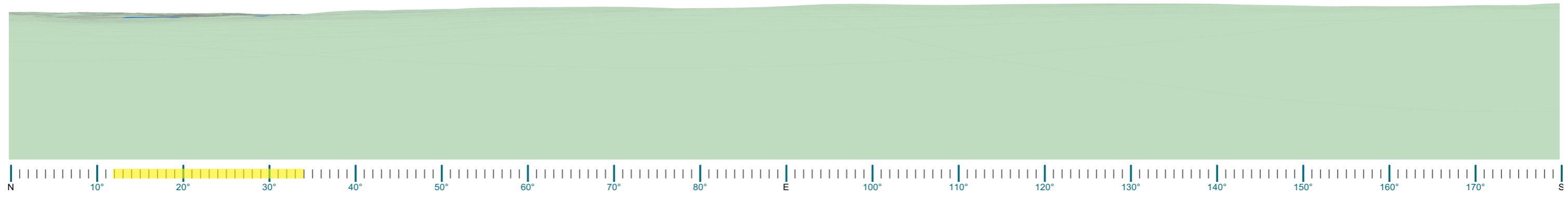

Extent of potentially visible solar panels  
(based on topography alone)

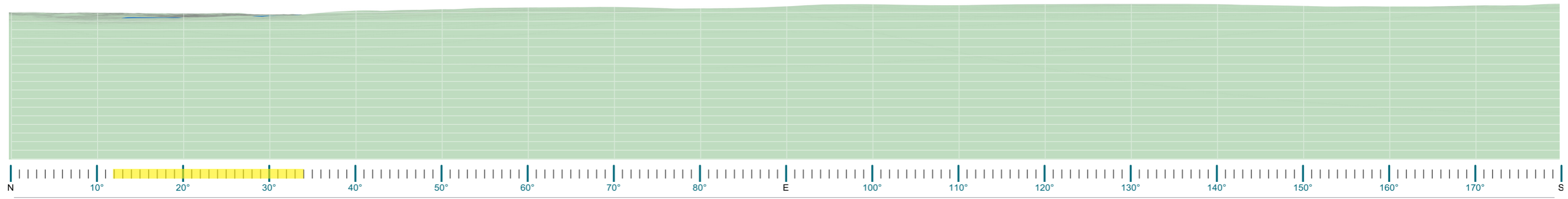
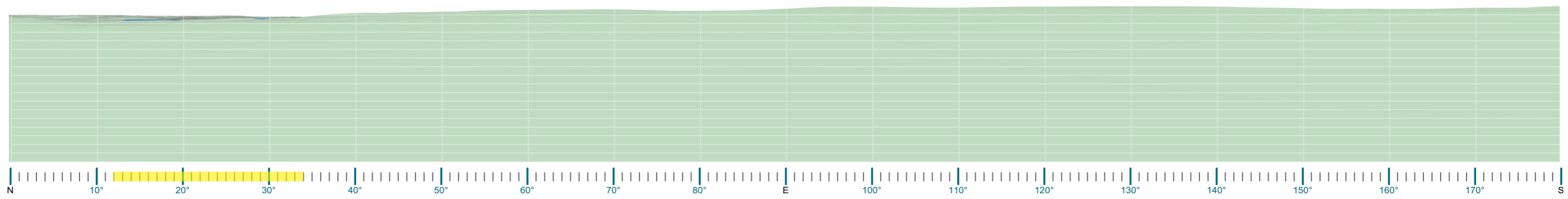

Dwelling/Public Viewpoint ID:  
**PR\_15**

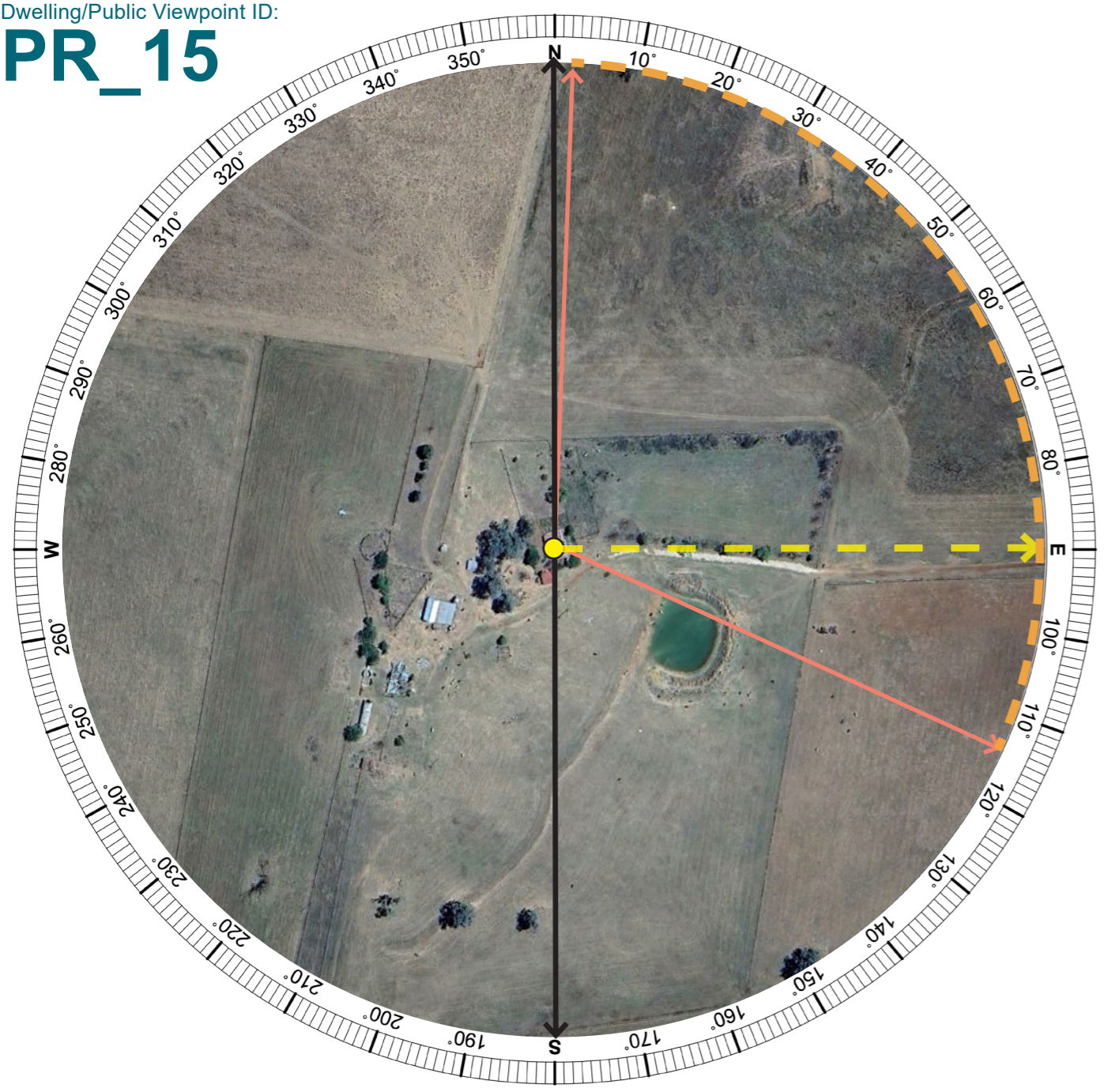

**LEGEND**

- Direction of potential visible Development Footprint (based on topography alone)
- Extent of potential visible Development Footprint (based on topography alone)
- Direction of the Wireframe
- Extent of Panorama
- Location of the viewpoint

Aerial Image - Wireframe Location (Aerial Image Source: Google Earth 2023)

**Residential Receptor PR\_15**

Receptor Assessment:									
Coordinates	Distance to development:	Viewpoint Type:	Receptor Sensitivity:	Scenic Quality:	Overall Sensitivity:	Occupied Cells:	Magnitude Rating:	Preliminary Visual Impact Rating:	Site Visit Required?
32°10'0.77"S 149°10'41.50"E	0.80 km	Residential Receptor	Moderate	Low	Moderate	10	Low	Low	YES / <b>NO</b>

**OCCUPIED CELL COUNT (TRANSMISSION LINES)**  
 Occupied Cell (greater than 3 degrees height)  
 A cell is unoccupied if the transmission lines do not occupy more than three vertical degrees of view or 3 vertical cells.

**OCCUPIED CELL COUNT (SOLAR FARM)**  
 Occupied Cell (greater than 25%)  
 A cell is unoccupied if elements of the project, including solar panels, battery energy systems, or other associated infrastructure do not occupy more than approximately 25% of a cell.

**Further Assessment Required:**

Yes  No

PR\_15  
Residential Receptor

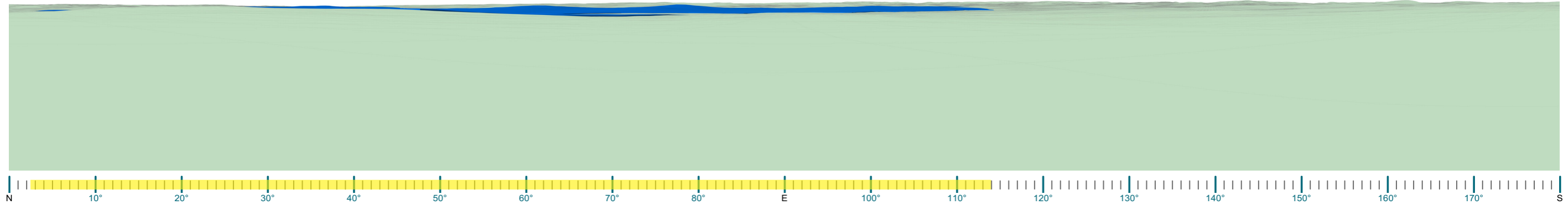

Extent of potentially visible solar panels (based on topography alone)

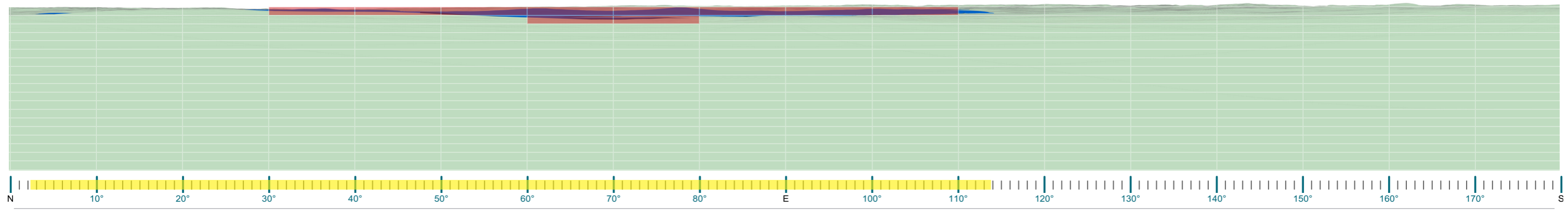
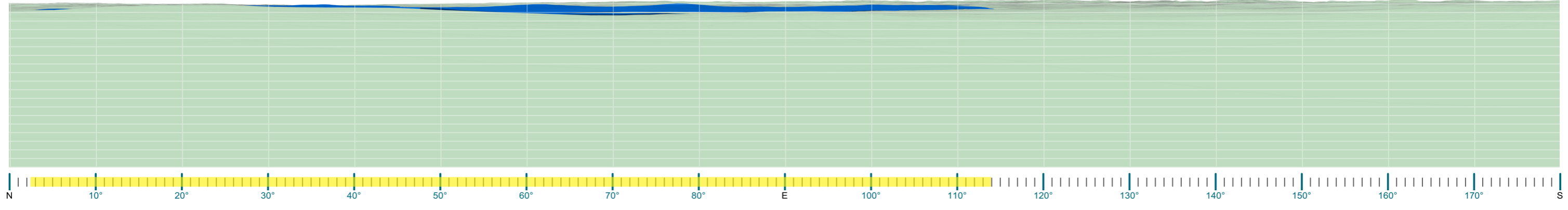

Dwelling/Public Viewpoint ID:  
**PR\_16**

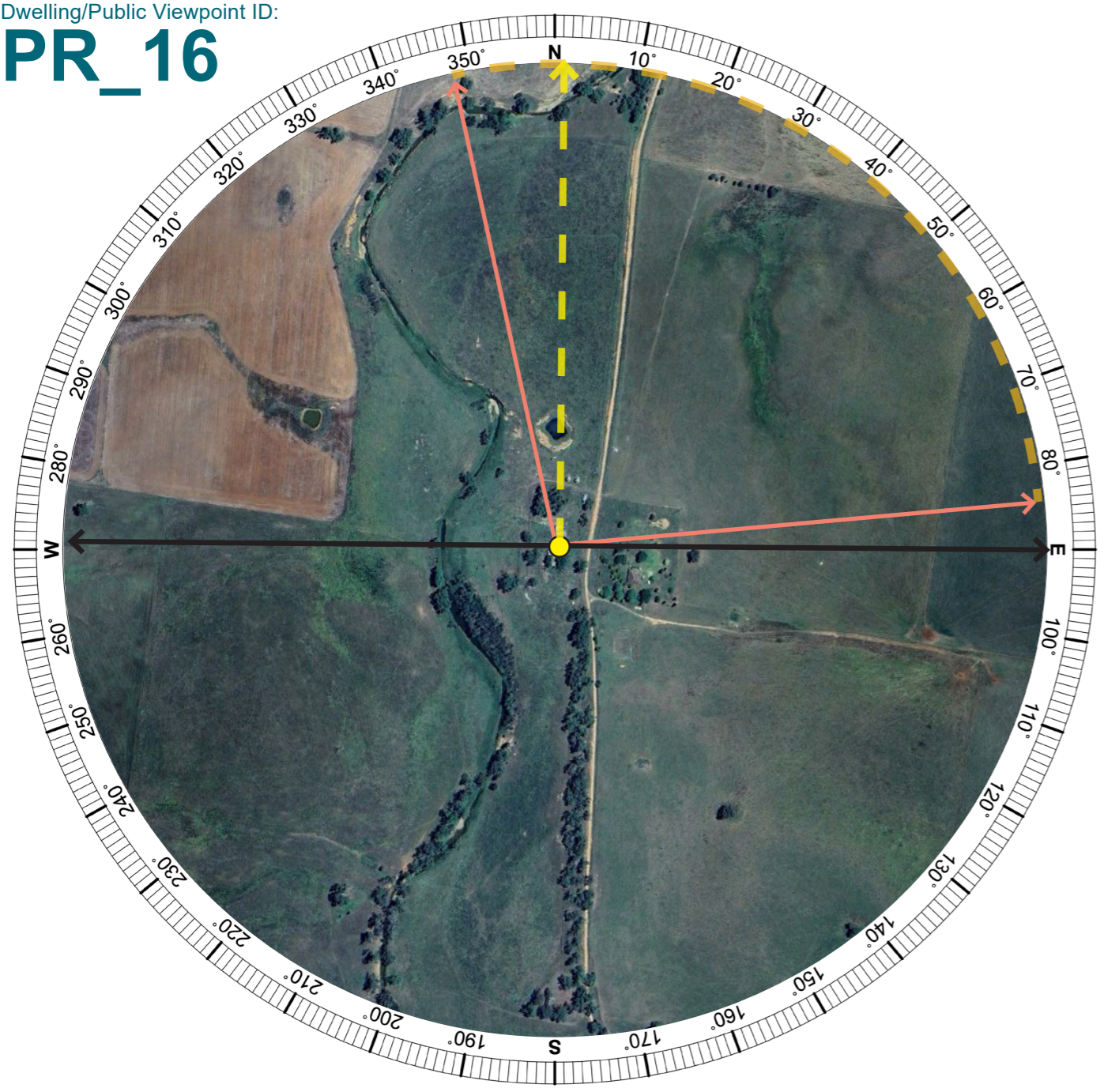

**LEGEND**

- Direction of potential visible Development Footprint (based on topography alone)
- - Extent of potential visible Development Footprint (based on topography alone)
- - - Direction of the Wireframe
- ↔ Extent of Panorama
- Location of the viewpoint

Aerial Image - Wireframe Location (Aerial Image Source: Google Earth 2023)

**Residential Receptor PR\_16**

Receptor Assessment:									
Coordinates	Distance to development:	Viewpoint Type:	Receptor Sensitivity:	Scenic Quality:	Overall Sensitivity:	Occupied Cells:	Magnitude Rating:	Preliminary Visual Impact Rating:	Site Visit Required?
32°11'34.80"S 149°13'6.26"E	1.16 km	Residential Receptor	Moderate	Low	Moderate	8	Low	Low	YES / <b>NO</b>

**OCCUPIED CELL COUNT (TRANSMISSION LINES)**  
■ Occupied Cell (greater than 3 degrees height)  
A cell is unoccupied if the transmission lines do not occupy more than three vertical degrees of view or 3 vertical cells.

**OCCUPIED CELL COUNT (SOLAR FARM)**  
■ Occupied Cell (greater than 25%)  
A cell is unoccupied if elements of the project, including solar panels, battery energy systems, or other associated infrastructure do not occupy more than approximately 25% of a cell.

**Further Assessment Required:**  
 Yes  No

PR\_16  
Residential Receptor

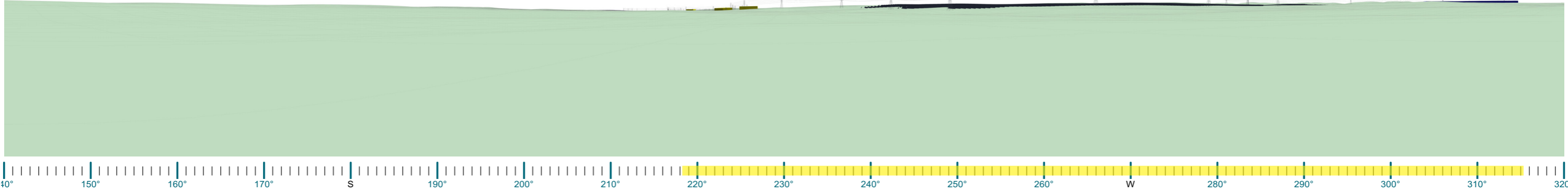

← Extent of potentially visible solar panels (based on topography alone) →

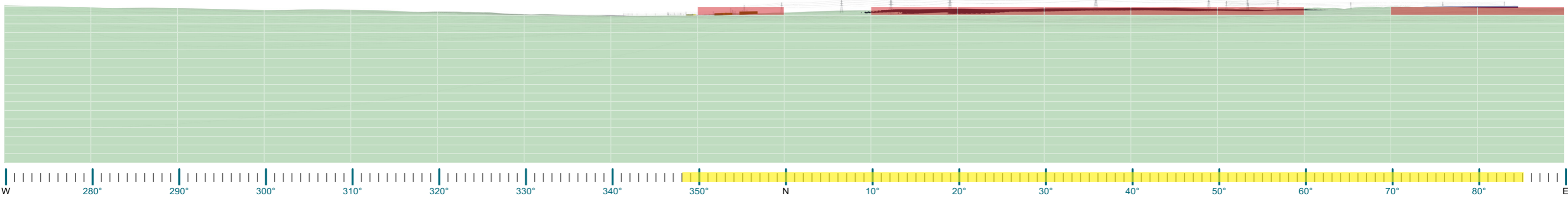
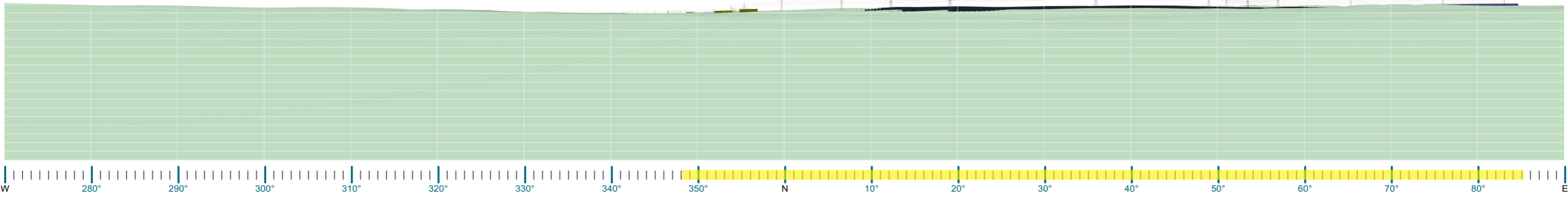



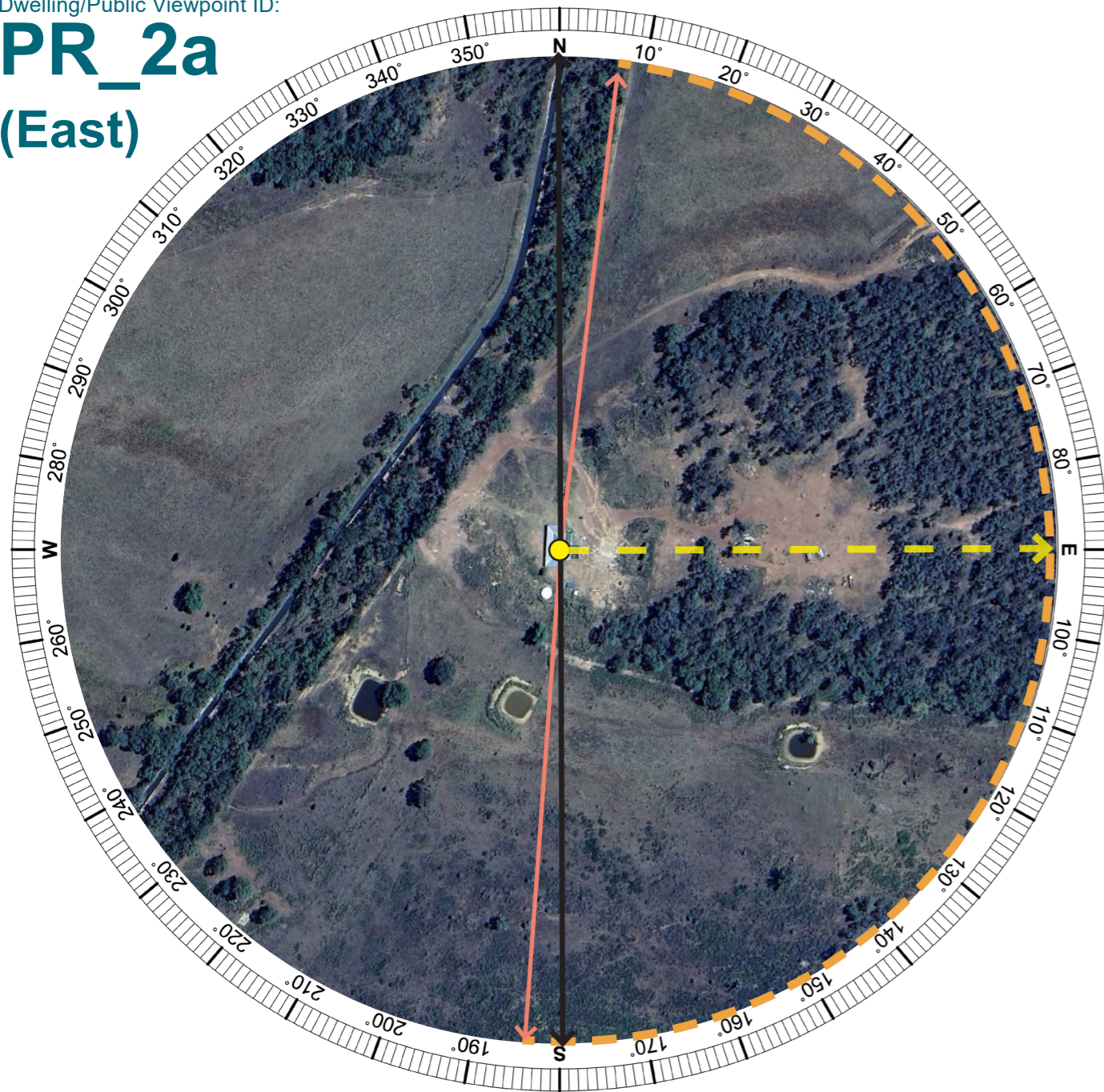

Dwelling/Public Viewpoint ID:

# PR\_2a (East)



### LEGEND

-  Direction of potential visible Development Footprint (based on topography alone)
-  Extent of potential visible Development Footprint (based on topography alone)
-  Direction of the Wireframe
-  Extent of Panorama
-  Location of the viewpoint

Aerial Image - Wireframe Location (Aerial Image Source: Google Earth 2023)

### OCCUPIED CELL COUNT (TRANSMISSION LINES)

 Occupied Cell (greater than 3 degrees height)

A cell is unoccupied if the transmission lines do not occupy more than three vertical degrees of view or 3 vertical cells.

PR\_2b (East)  
Residential Receptor

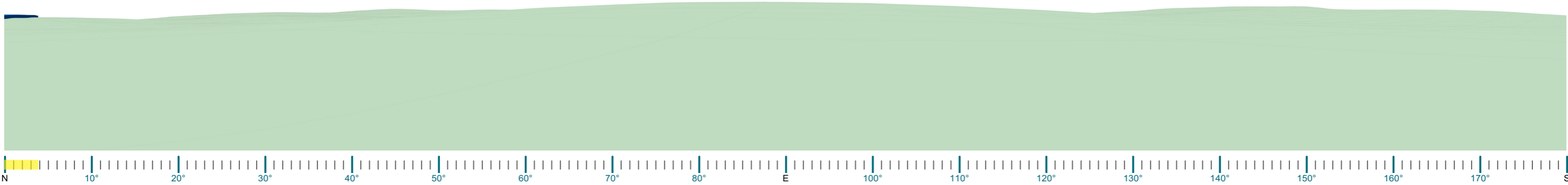

Extent of potentially visible solar panels  
(based on topography alone)

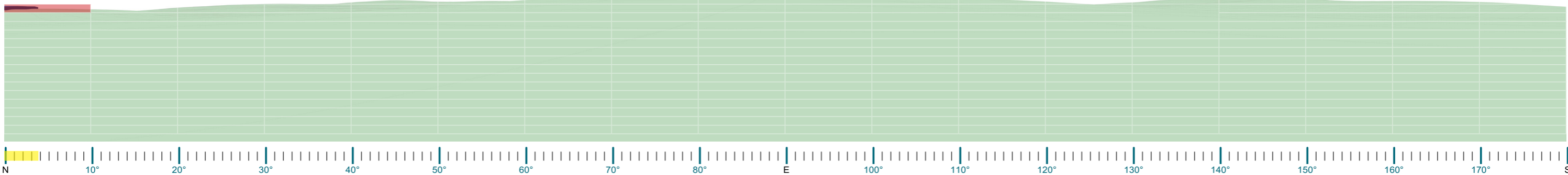
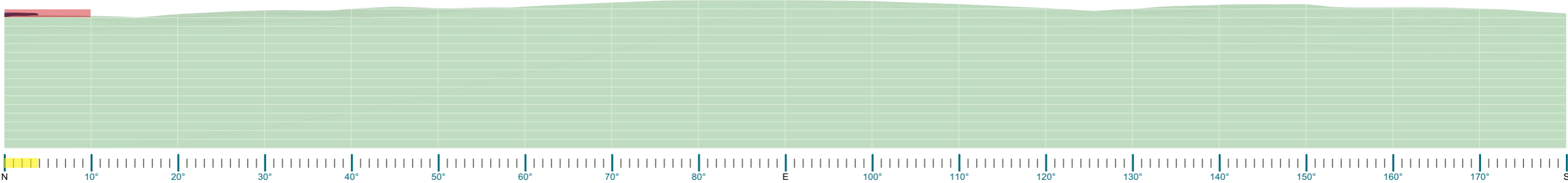

Dwelling/Public Viewpoint ID:

# PR\_2b (West)

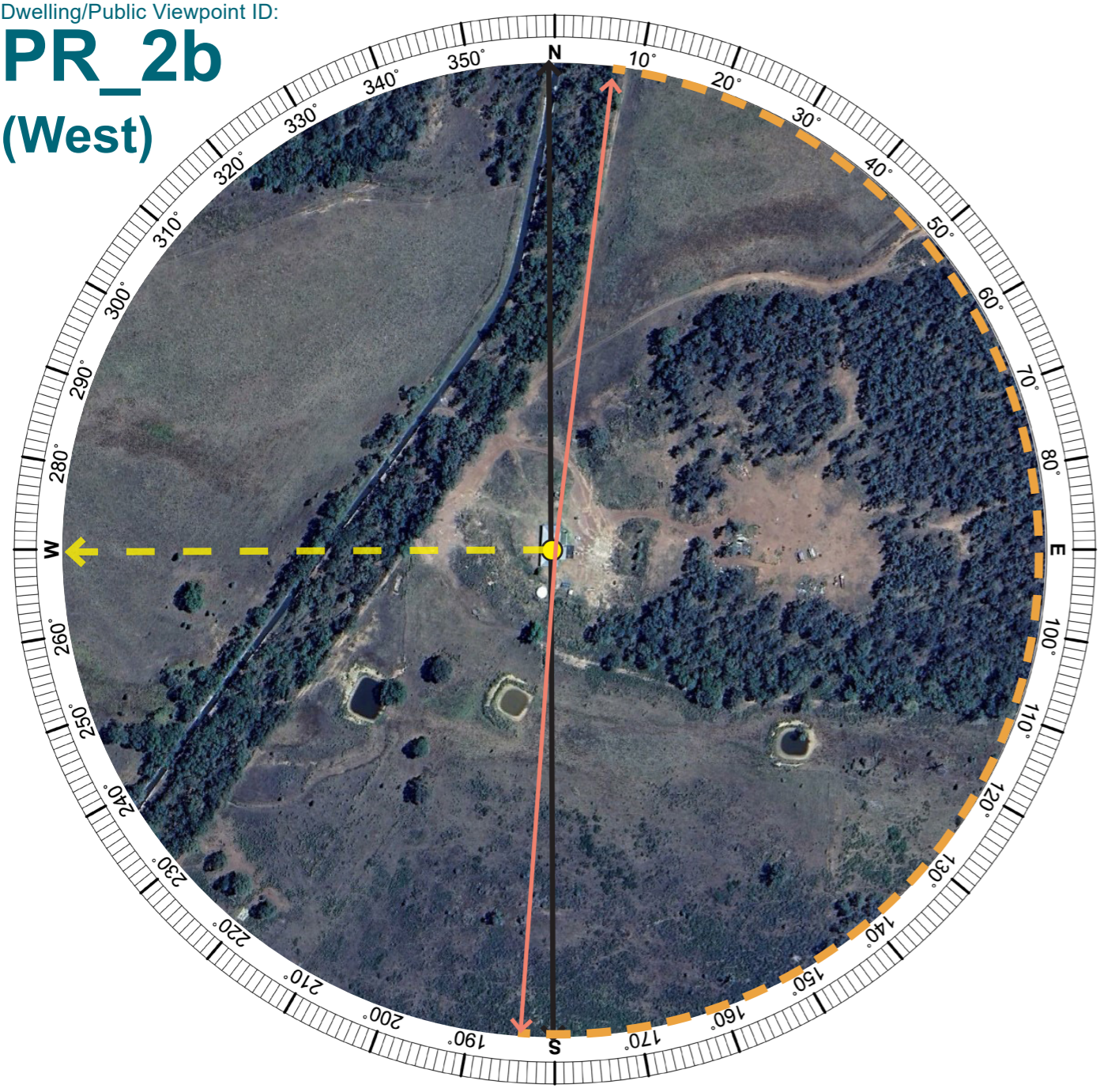

### LEGEND

- Direction of potential visible Development Footprint (based on topography alone)
- Extent of potential visible Development Footprint (based on topography alone)
- Direction of the Wireframe
- Extent of Panorama
- Location of the viewpoint

Aerial Image - Wireframe Location (Aerial Image Source: Google Earth 2023)

## Residential Receptor PR\_2 (East & West)

Receptor Assessment:									
Coordinates	Distance to development:	Viewpoint Type:	Receptor Sensitivity:	Scenic Quality:	Overall Sensitivity:	Occupied Cells:	Magnitude Rating:	Preliminary Visual Impact Rating:	Site Visit Required?
32° 7'37.18"S 149° 13'48.08"E	0.19 km	Residential Receptor	Moderate	Low	Moderate	37	Very High	High	<b>YES</b> / NO

**OCCUPIED CELL COUNT (TRANSMISSION LINES)**  
 Occupied Cell (greater than 3 degrees height)  
A cell is unoccupied if the transmission lines do not occupy more than three vertical degrees of view or 3 vertical cells.

**OCCUPIED CELL COUNT (SOLAR FARM)**  
 Occupied Cell (greater than 25%)  
A cell is unoccupied if elements of the project, including solar panels, battery energy systems, or other associated infrastructure do not occupy more than approximately 25% of a cell.

### Further Assessment Required:

Yes  No

PR\_2a (West)  
Residential Receptor

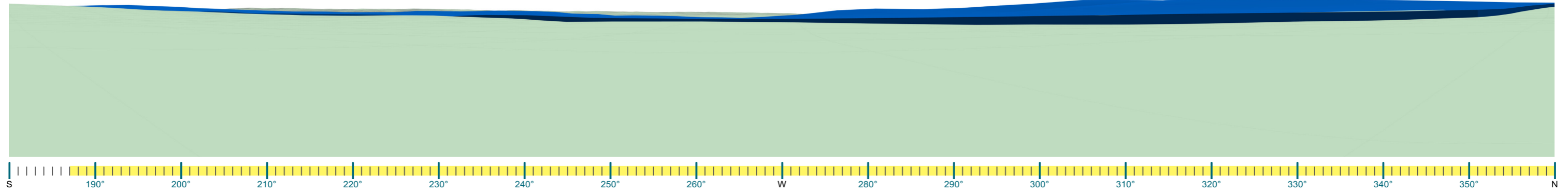

Extent of potentially visible solar panels (based on topography alone)

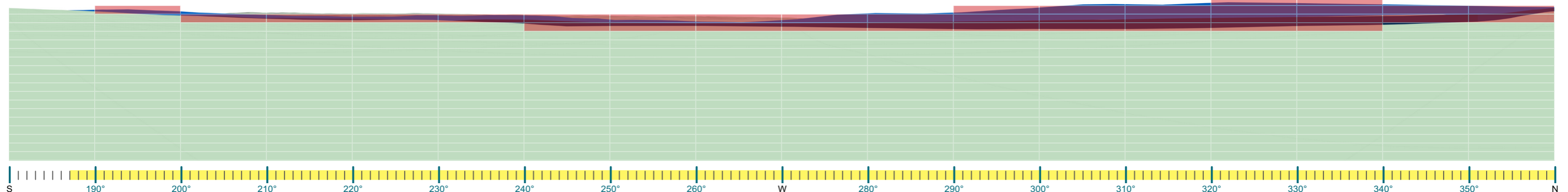
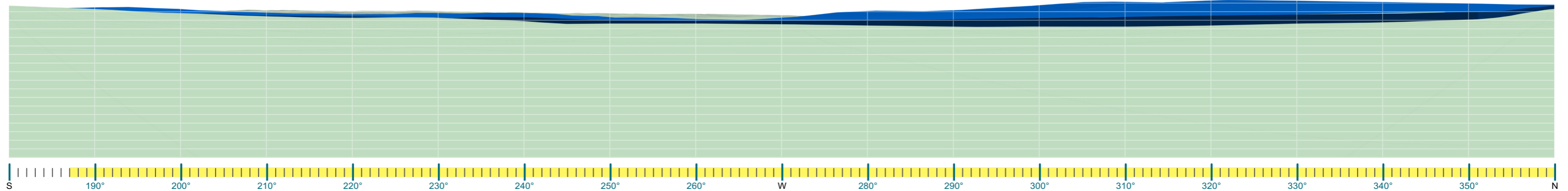

Dwelling/Public Viewpoint ID:  
**PR\_22**

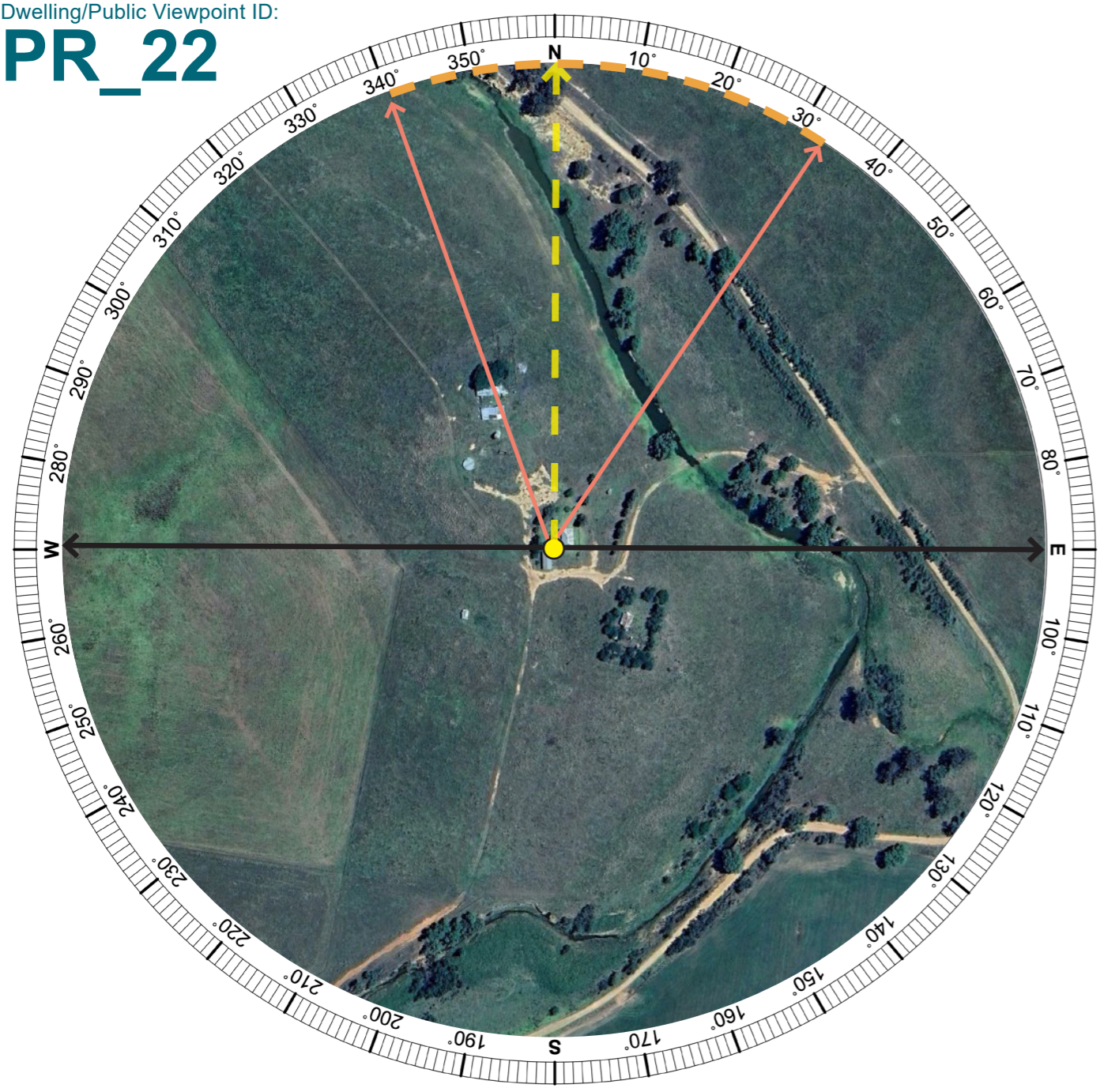

**LEGEND**

- Direction of potential visible Development Footprint (based on topography alone)
- Extent of potential visible Development Footprint (based on topography alone)
- Direction of the Wireframe
- ↔ Extent of Panorama
- Location of the viewpoint

Aerial Image - Wireframe Location (Aerial Image Source: Google Earth 2023)

**Residential Receptor PR\_22**

Receptor Assessment:									
Coordinates	Distance to development:	Viewpoint Type:	Receptor Sensitivity:	Scenic Quality:	Overall Sensitivity:	Occupied Cells:	Magnitude Rating:	Preliminary Visual Impact Rating:	Site Visit Required?
32°12'11.27"S 149°13'12.85"E	2.18 km	Residential Receptor	Moderate	Low	Moderate	6	Very Low	Low	YES / <span style="border: 2px solid #00728f; border-radius: 50%; padding: 2px 5px;">NO</span>

**OCCUPIED CELL COUNT (TRANSMISSION LINES)**

■ Occupied Cell (greater than 3 degrees height)

A cell is unoccupied if the transmission lines do not occupy more than three vertical degrees of view or 3 vertical cells.

**OCCUPIED CELL COUNT (SOLAR FARM)**

■ Occupied Cell (greater than 25%)

A cell is unoccupied if elements of the project, including solar panels, battery energy systems, or other associated infrastructure do not occupy more than approximately 25% of a cell.

**Further Assessment Required:**

Yes

No

PR\_22  
Residential Receptor

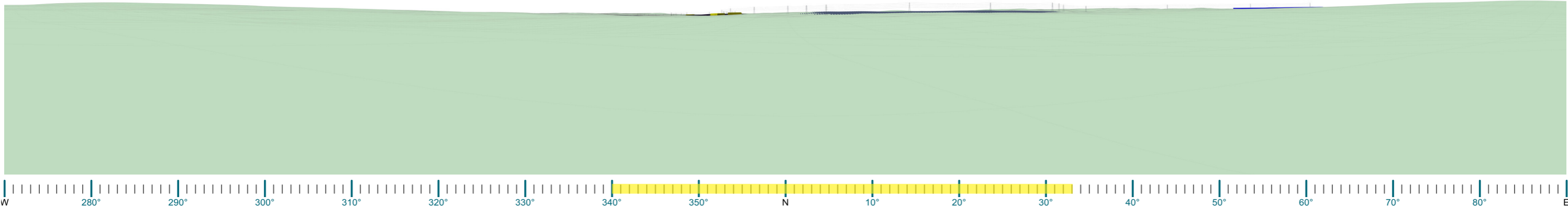

Extent of potentially visible solar panels (based on topography alone)

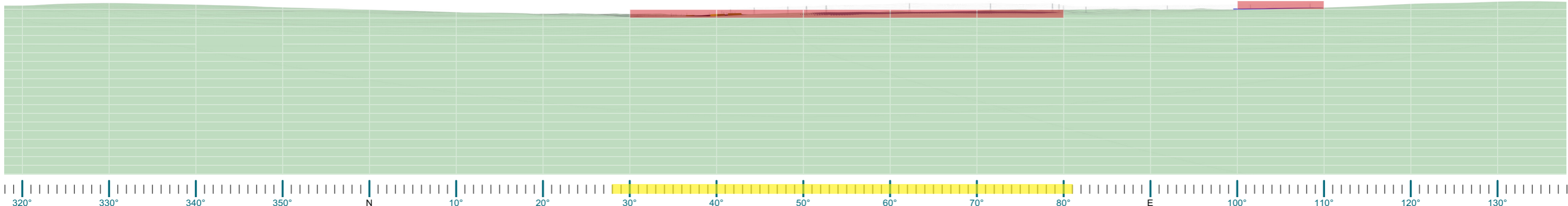
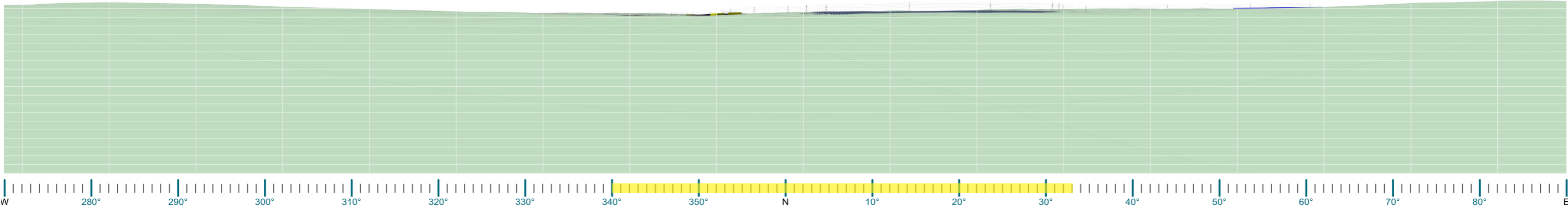

Dwelling/Public Viewpoint ID:  
**PR\_24**

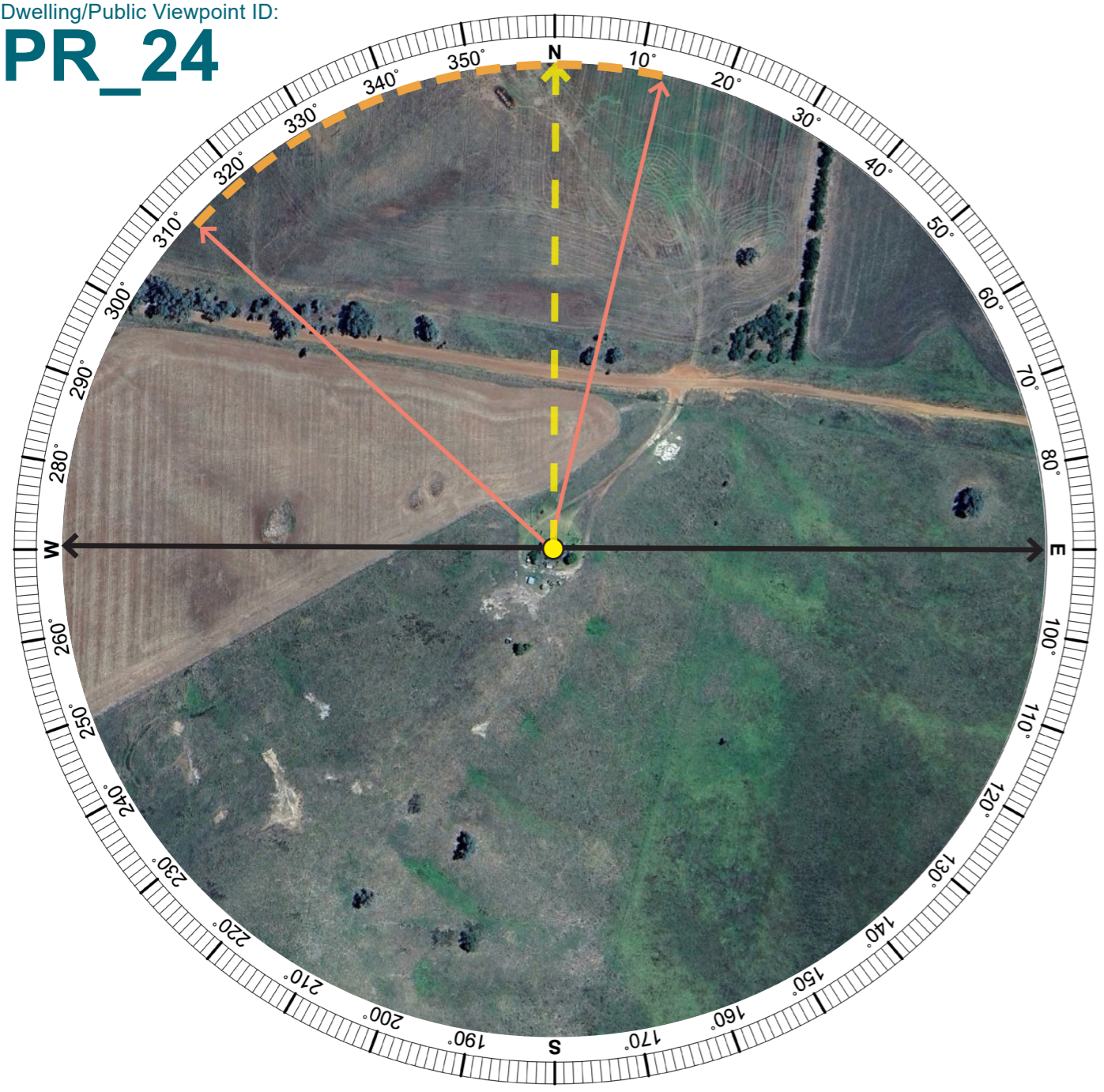

**LEGEND**

- Direction of potential visible Development Footprint (based on topography alone)
- Extent of potential visible Development Footprint (based on topography alone)
- Direction of the Wireframe
- Extent of Panorama
- Location of the viewpoint

Aerial Image - Wireframe Location (Aerial Image Source: Google Earth 2023)

**Residential Receptor PR\_24**

Receptor Assessment:									
Coordinates	Distance to development:	Viewpoint Type:	Receptor Sensitivity:	Scenic Quality:	Overall Sensitivity:	Occupied Cells:	Magnitude Rating:	Preliminary Visual Impact Rating:	Site Visit Required?
32°12'30.57"S 149°14'31.25"E	2.13 km	Residential Receptor	Moderate	Low	Moderate	6	Very Low	Low	YES / <b>NO</b>

**OCCUPIED CELL COUNT (TRANSMISSION LINES)**  
 Occupied Cell (greater than 3 degrees height)  
A cell is unoccupied if the transmission lines do not occupy more than three vertical degrees of view or 3 vertical cells.

**OCCUPIED CELL COUNT (SOLAR FARM)**  
 Occupied Cell (greater than 25%)  
A cell is unoccupied if elements of the project, including solar panels, battery energy systems, or other associated infrastructure do not occupy more than approximately 25% of a cell.

**Further Assessment Required:**

Yes  No



Dwelling/Public Viewpoint ID:

**PR\_3**

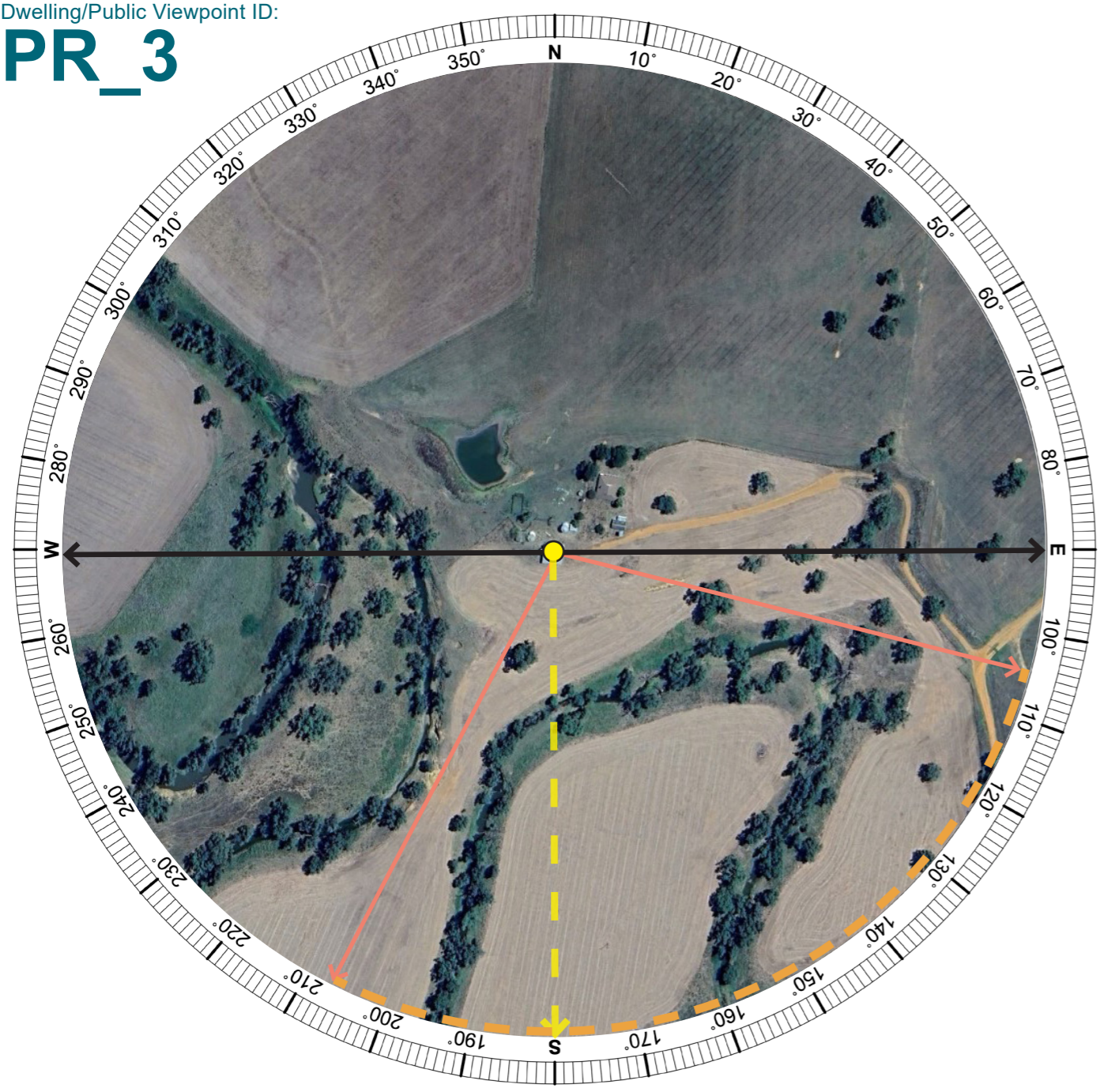

**LEGEND**

- Direction of potential visible Development Footprint (based on topography alone)
- Extent of potential visible Development Footprint (based on topography alone)
- Direction of the Wireframe
- ↔ Extent of Panorama
- Location of the viewpoint

Aerial Image - Wireframe Location (Aerial Image Source: Google Earth 2023)

**Residential Receptor PR\_3**

Receptor Assessment:									
Coordinates	Distance to development:	Viewpoint Type:	Receptor Sensitivity:	Scenic Quality:	Overall Sensitivity:	Occupied Cells:	Magnitude Rating:	Preliminary Visual Impact Rating:	Site Visit Required?
32° 6'11.44"S 149° 11'30.37"E	0.80 km	Residential Receptor	Moderate	Low	Moderate	13	Low	Low	YES / <b>NO</b>

**OCCUPIED CELL COUNT (TRANSMISSION LINES)**

■ Occupied Cell (greater than 3 degrees height)

A cell is unoccupied if the transmission lines do not occupy more than three vertical degrees of view or 3 vertical cells.

**OCCUPIED CELL COUNT (SOLAR FARM)**

■ Occupied Cell (greater than 25%)

A cell is unoccupied if elements of the project, including solar panels, battery energy systems, or other associated infrastructure do not occupy more than approximately 25% of a cell.

**Further Assessment Required:**

Yes  No

PR\_3  
Residential Receptor

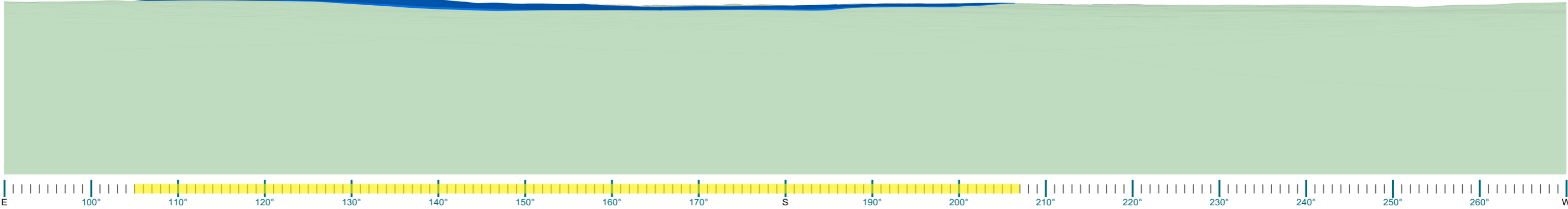

← Extent of potentially visible solar panels (based on topography alone) →

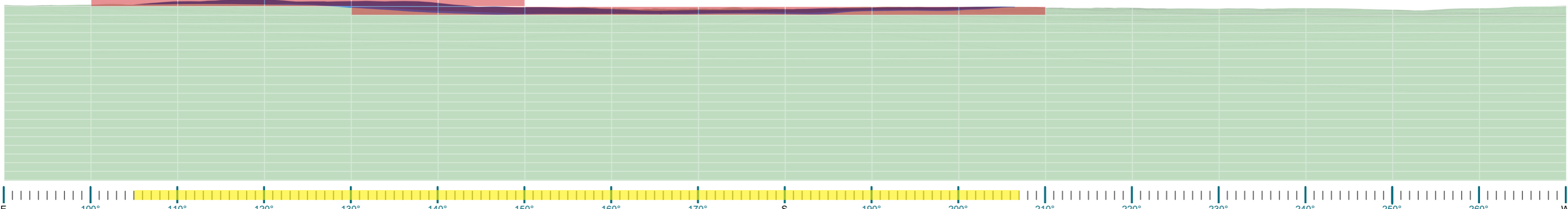
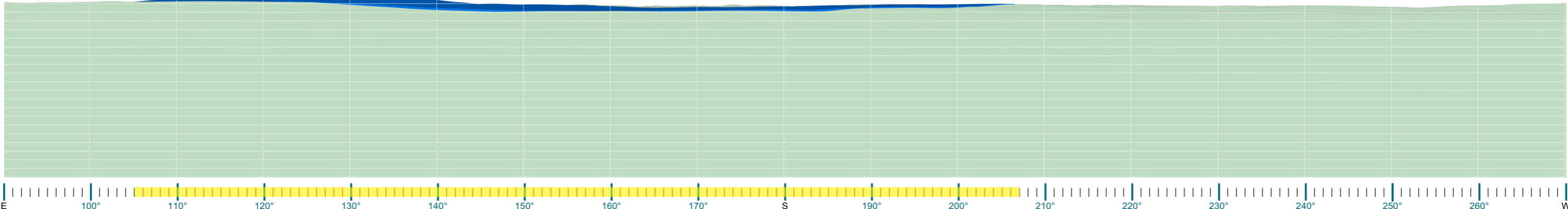



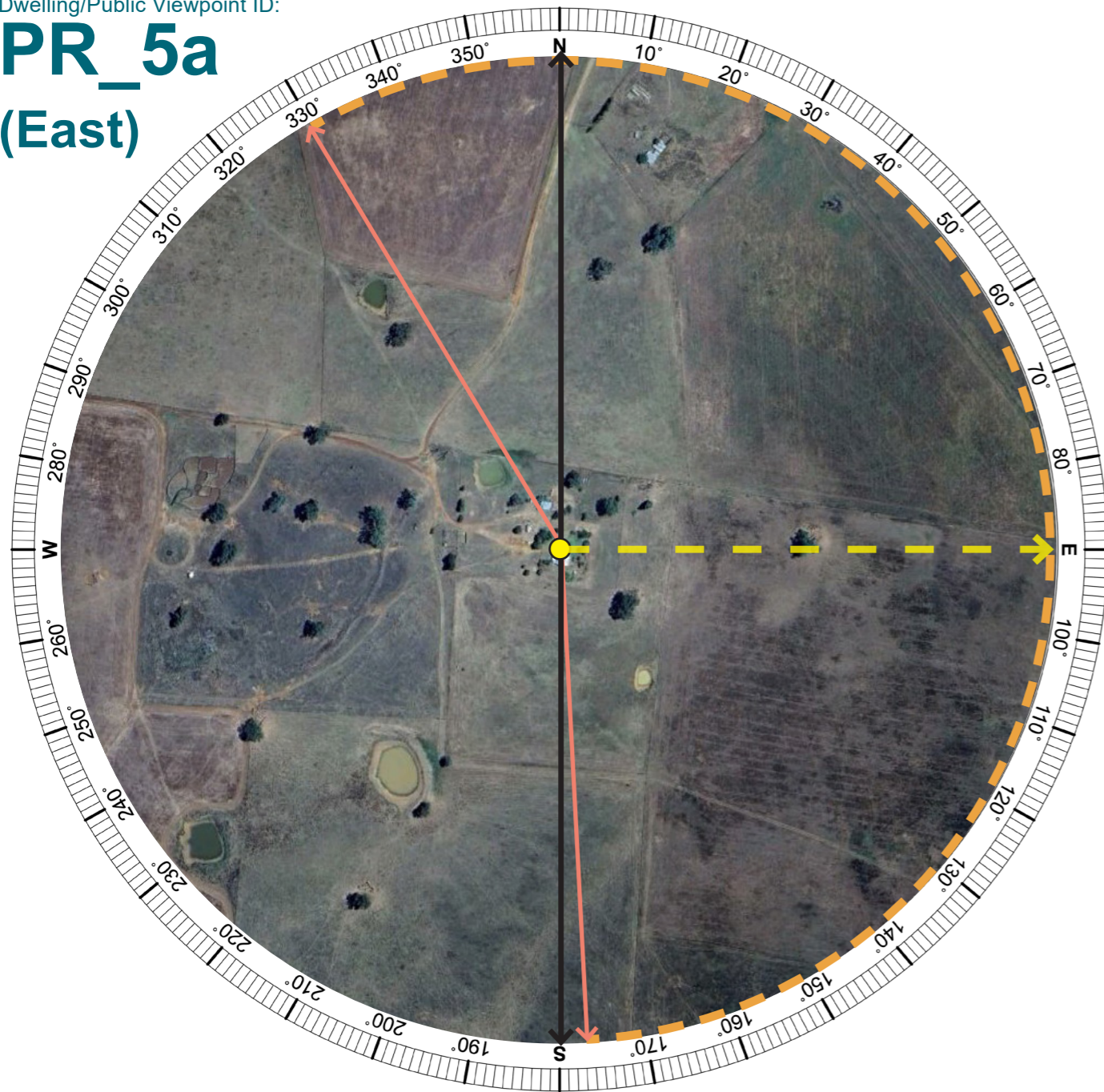

Dwelling/Public Viewpoint ID:

# PR\_5a (East)



### LEGEND

-  Direction of potential visible Development Footprint (based on topography alone)
-  Extent of potential visible Development Footprint (based on topography alone)
-  Direction of the Wireframe
-  Extent of Panorama
-  Location of the viewpoint

Aerial Image - Wireframe Location (Aerial Image Source: Google Earth 2023)

### OCCUPIED CELL COUNT (TRANSMISSION LINES)

 Occupied Cell (greater than 3 degrees height)

A cell is unoccupied if the transmission lines do not occupy more than three vertical degrees of view or 3 vertical cells.

PR\_5a (East)  
Residential Receptor

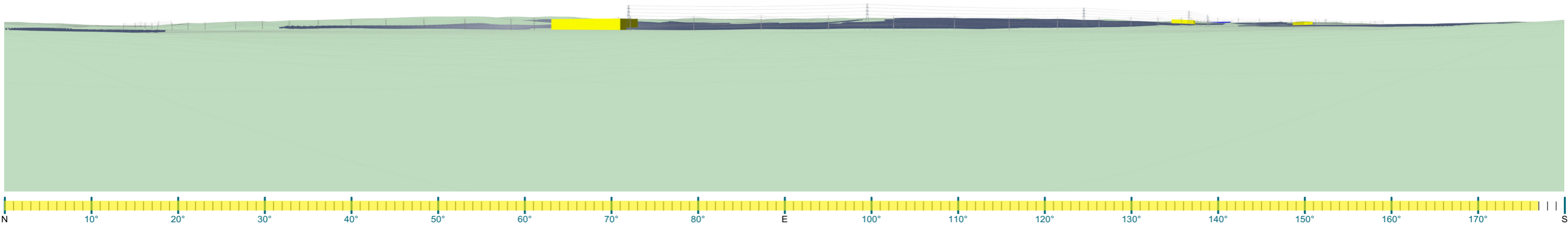

Extent of potentially visible solar panels (based on topography alone)

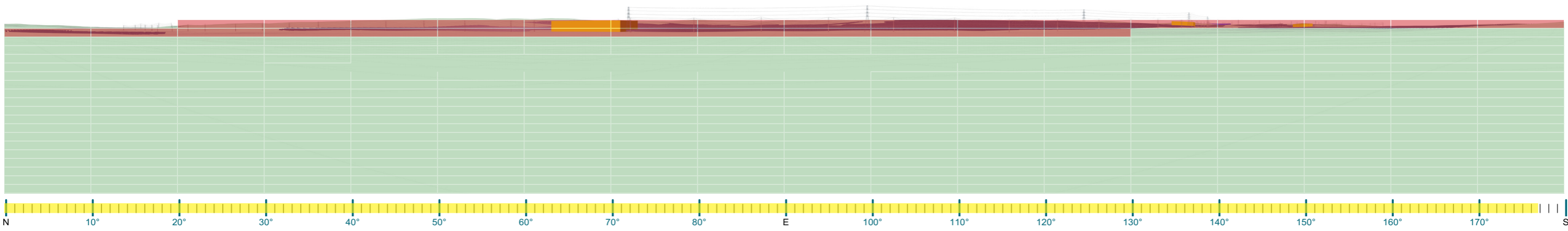
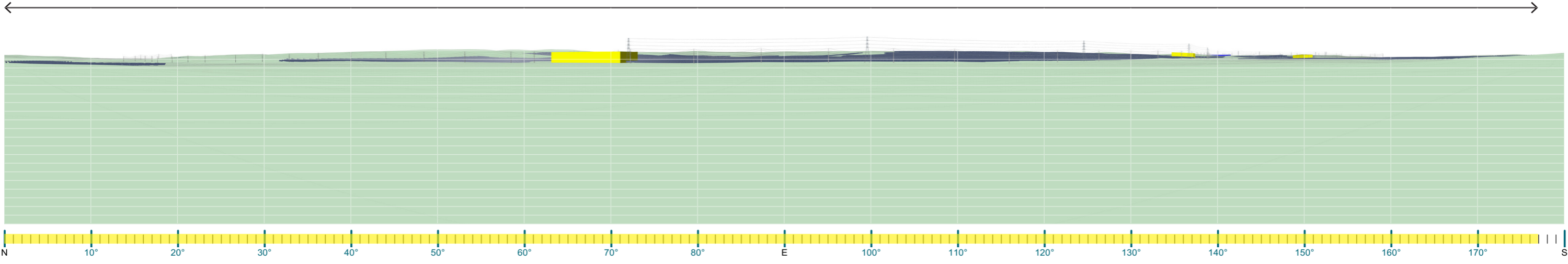

Dwelling/Public Viewpoint ID:  
**PR\_5b**  
**(West)**

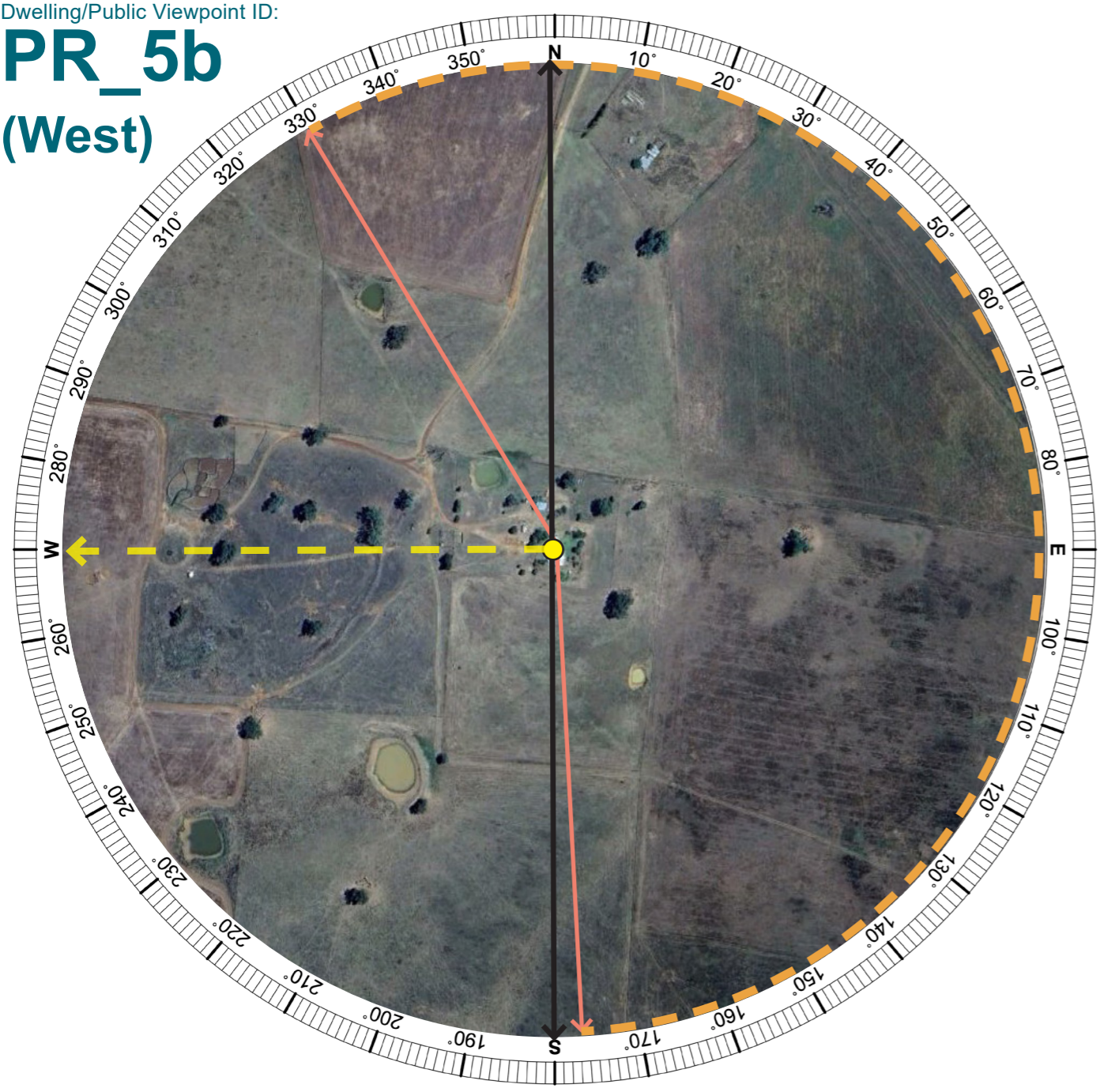

**LEGEND**

- Direction of potential visible Development Footprint (based on topography alone)
- Extent of potential visible Development Footprint (based on topography alone)
- Direction of the Wireframe
- Extent of Panorama
- Location of the viewpoint

Aerial Image - Wireframe Location (Aerial Image Source: Google Earth 2023)

**Residential Receptor PR\_5 (East & West)**

Receptor Assessment:									
Coordinates	Distance to development:	Viewpoint Type:	Receptor Sensitivity:	Scenic Quality:	Overall Sensitivity:	Occupied Cells:	Magnitude Rating:	Preliminary Visual Impact Rating:	Site Visit Required?
32° 7'52.52"S 149° 11'33.84"E	0.75 km	Residential Receptor	Moderate	Low	Moderate	32	High	Moderate	<b>YES</b> / NO

**OCCUPIED CELL COUNT (TRANSMISSION LINES)**  
 Occupied Cell (greater than 3 degrees height)  
A cell is unoccupied if the transmission lines do not occupy more than three vertical degrees of view or 3 vertical cells.

**OCCUPIED CELL COUNT (SOLAR FARM)**  
 Occupied Cell (greater than 25%)  
A cell is unoccupied if elements of the project, including solar panels, battery energy systems, or other associated infrastructure do not occupy more than approximately 25% of a cell.

**Further Assessment Required:**  
 **Yes**       **No**

PR\_5b (West)  
Residential Receptor

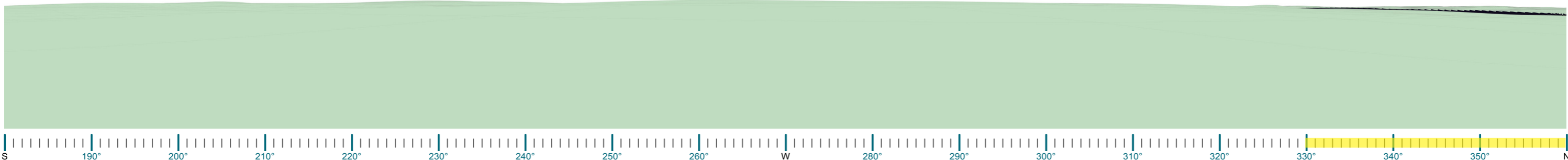

Extent of potentially visible solar panels  
(based on topography alone)

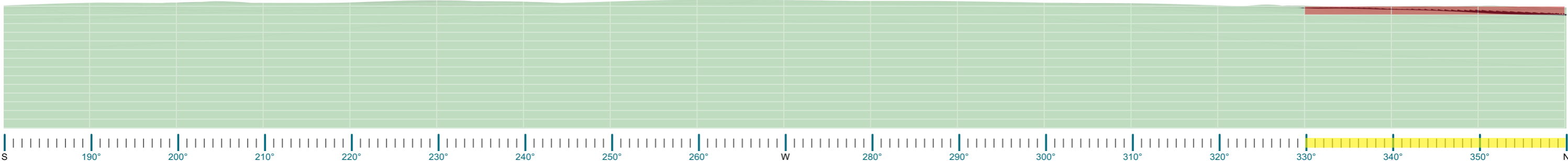
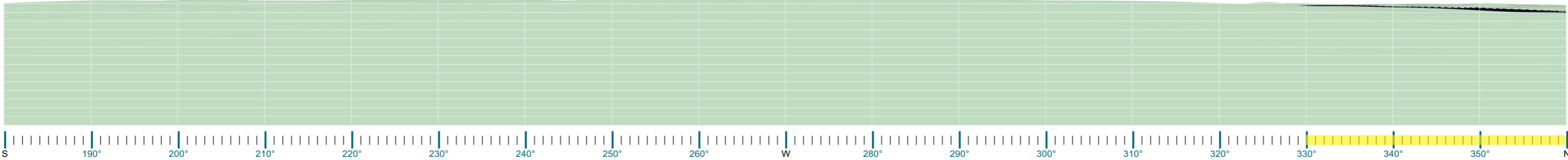

Dwelling/Public Viewpoint ID:

# PR\_6a (North)

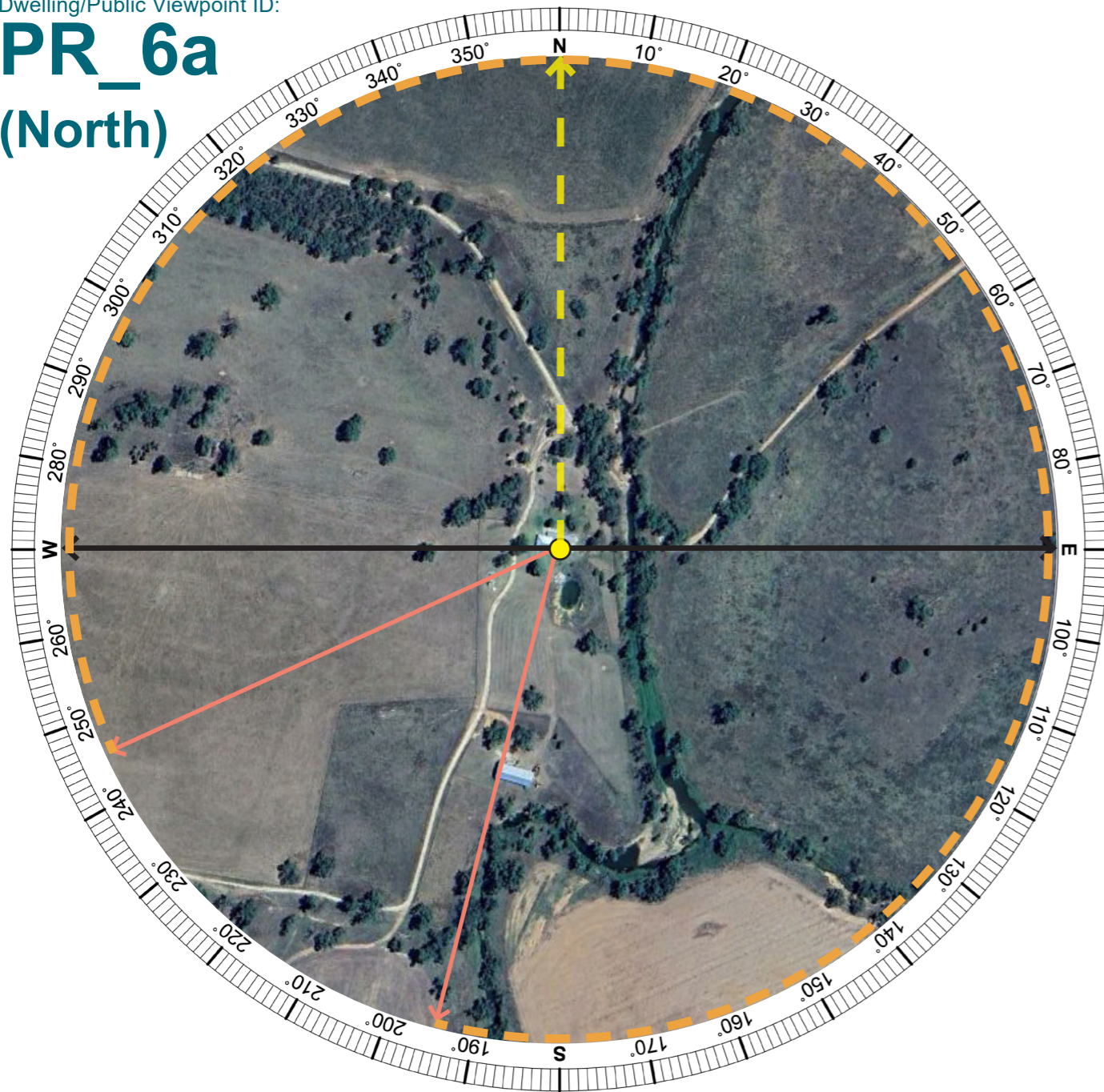

### LEGEND

- Direction of potential visible Development Footprint (based on topography alone)
- Extent of potential visible Development Footprint (based on topography alone)
- Direction of the Wireframe
- Extent of Panorama
- Location of the viewpoint

Aerial Image - Wireframe Location (Aerial Image Source: Google Earth 2023)

**OCCUPIED CELL COUNT (TRANSMISSION LINES)**

Occupied Cell (greater than 3 degrees height)

A cell is unoccupied if the transmission lines do not occupy more than three vertical degrees of view or 3 vertical cells.

PR\_6a (North)  
Residential Receptor

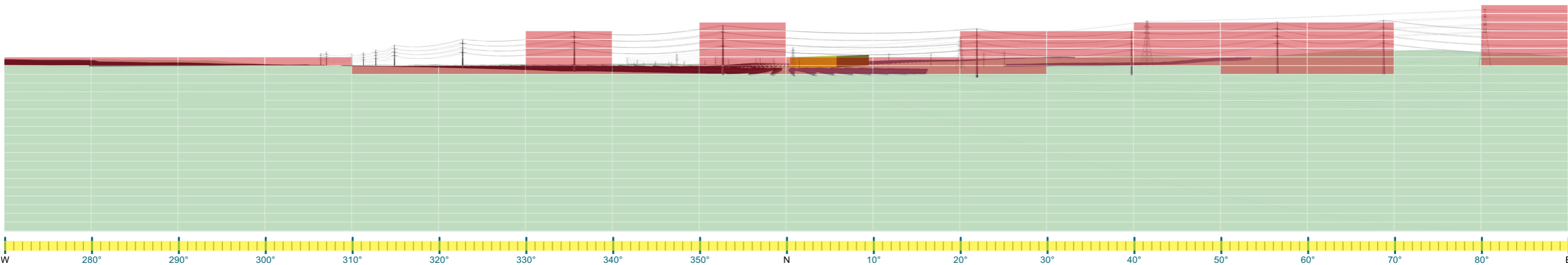
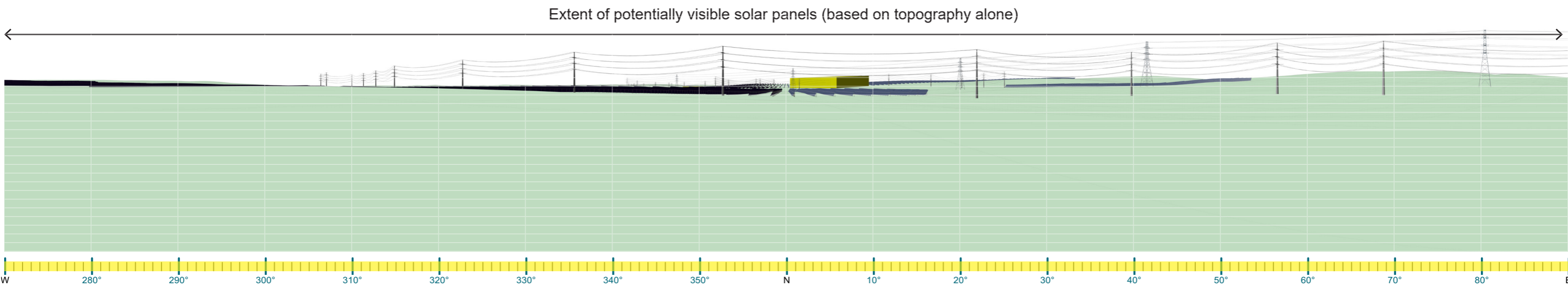
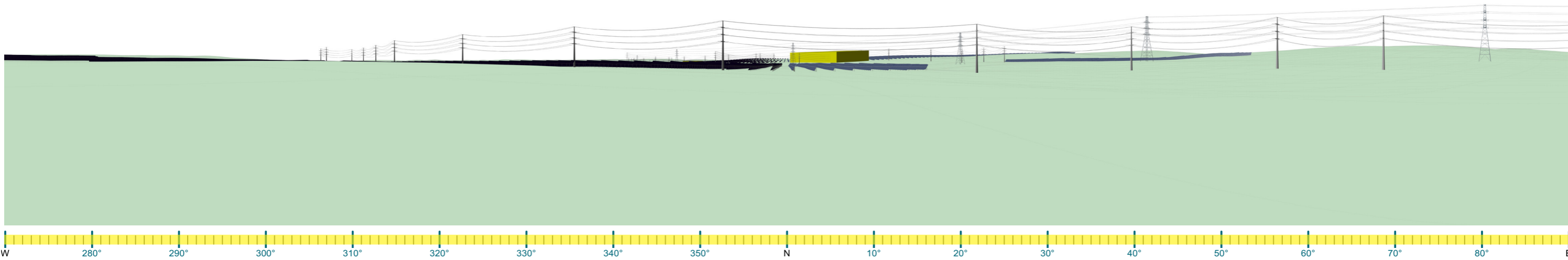

Dwelling/Public Viewpoint ID:

# PR\_6b (South)

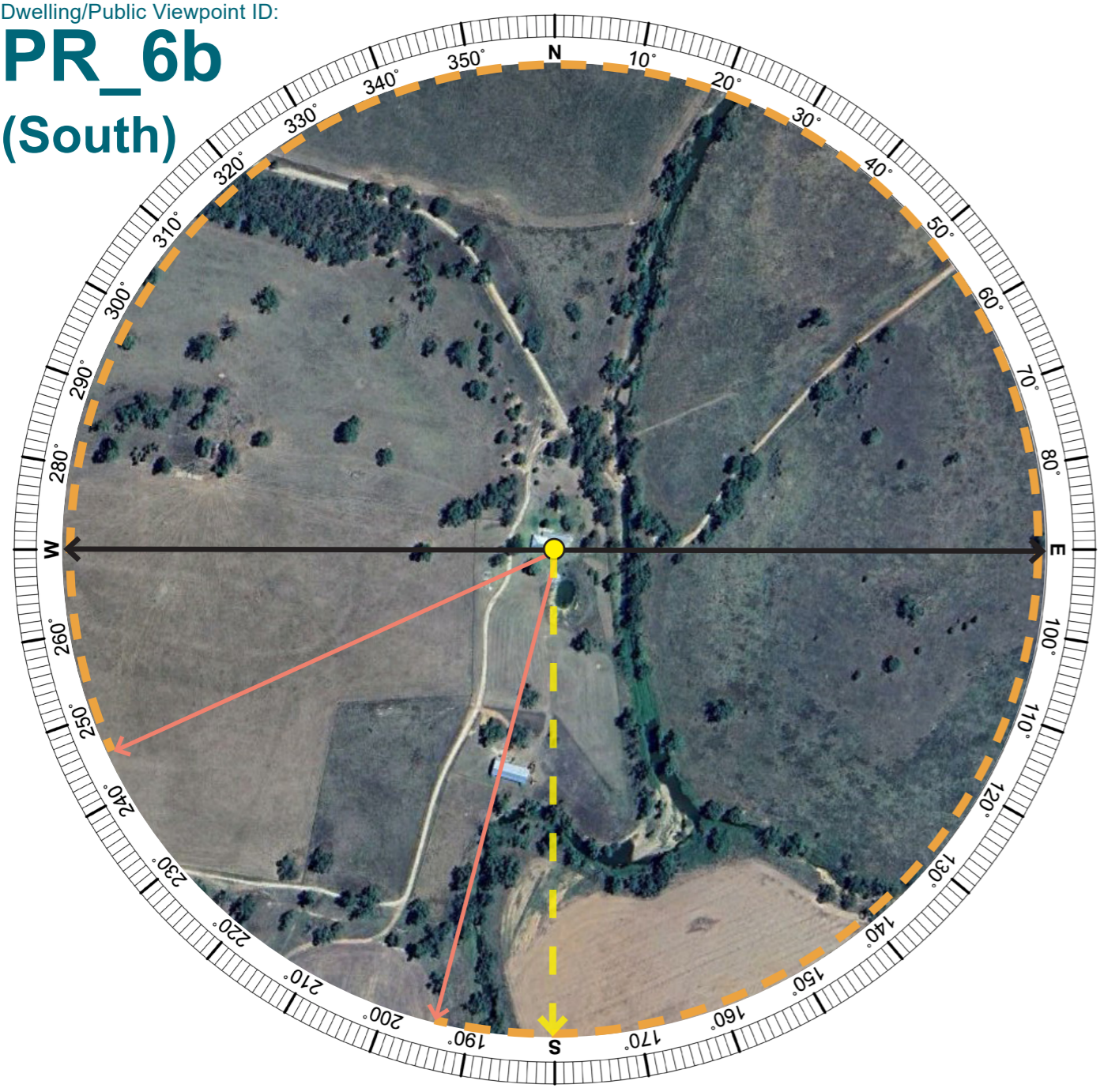

### LEGEND

- Direction of potential visible Development Footprint (based on topography alone)
- Extent of potential visible Development Footprint (based on topography alone)
- Direction of the Wireframe
- ↔ Extent of Panorama
- Location of the viewpoint

Aerial Image - Wireframe Location (Aerial Image Source: Google Earth 2023)

## Residential Receptor PR\_6 (North & South)

Receptor Assessment:									
Coordinates	Distance to development:	Viewpoint Type:	Receptor Sensitivity:	Scenic Quality:	Overall Sensitivity:	Occupied Cells:	Magnitude Rating:	Preliminary Visual Impact Rating:	Site Visit Required?
32° 9'32.77"S 149° 12'38.82"E	0.27 km	Residential Receptor	Moderate	Low	Moderate	87	Very High	High	<span style="border: 1px solid black; border-radius: 50%; padding: 2px;">YES</span> / NO

**OCCUPIED CELL COUNT (TRANSMISSION LINES)**

■ Occupied Cell (greater than 3 degrees height)

A cell is unoccupied if the transmission lines do not occupy more than three vertical degrees of view or 3 vertical cells.

**OCCUPIED CELL COUNT (SOLAR FARM)**

■ Occupied Cell (greater than 25%)

A cell is unoccupied if elements of the project, including solar panels, battery energy systems, or other associated infrastructure do not occupy more than approximately 25% of a cell.

### Further Assessment Required:

**Yes**  **No**

PR\_6b (South)  
Residential Receptor

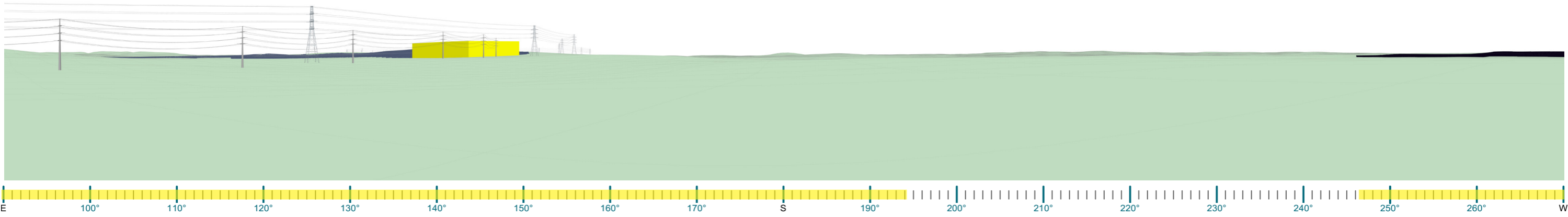

Extent of potentially visible solar panels (based on topography alone)

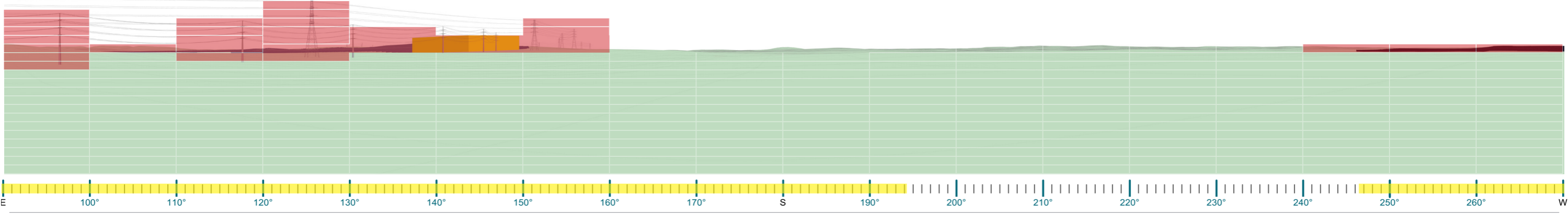
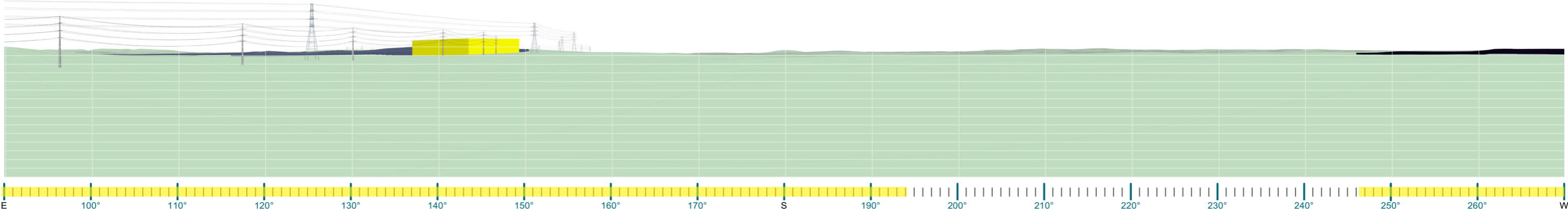

Dwelling/Public Viewpoint ID:

**PR\_9**

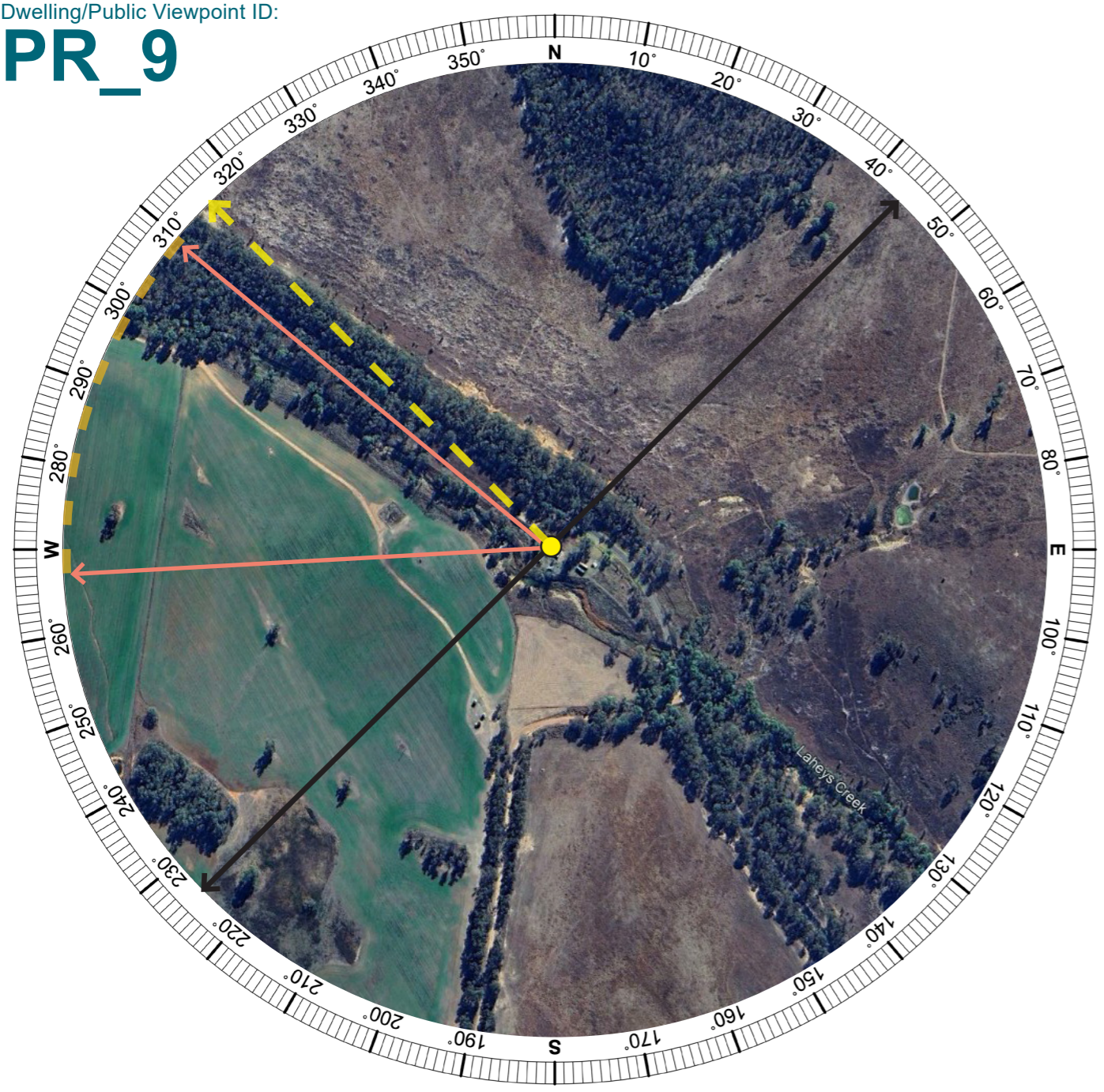

**LEGEND**

- Direction of potential visible Development Footprint (based on topography alone)
- Extent of potential visible Development Footprint (based on topography alone)
- Direction of the Wireframe
- Extent of Panorama
- Location of the viewpoint

Aerial Image - Wireframe Location (Aerial Image Source: Google Earth 2023)

**Residential Receptor PR\_9**

Receptor Assessment:									
Coordinates	Distance to development:	Viewpoint Type:	Receptor Sensitivity:	Scenic Quality:	Overall Sensitivity:	Occupied Cells:	Magnitude Rating:	Preliminary Visual Impact Rating:	Site Visit Required?
32°11'22.68"S 149°16'16.84"E	1.38 km	Residential Receptor	Moderate	Low	Moderate	5	Very Low	Low	YES / <b>NO</b>

**OCCUPIED CELL COUNT (TRANSMISSION LINES)**  
 Occupied Cell (greater than 3 degrees height)  
 A cell is unoccupied if the transmission lines do not occupy more than three vertical degrees of view or 3 vertical cells.

**OCCUPIED CELL COUNT (SOLAR FARM)**  
 Occupied Cell (greater than 25%)  
 A cell is unoccupied if elements of the project, including solar panels, battery energy systems, or other associated infrastructure do not occupy more than approximately 25% of a cell.

**Further Assessment Required:**

Yes  No

PR\_9  
Residential Receptor



Extent of potentially visible solar panels  
(based on topography alone)

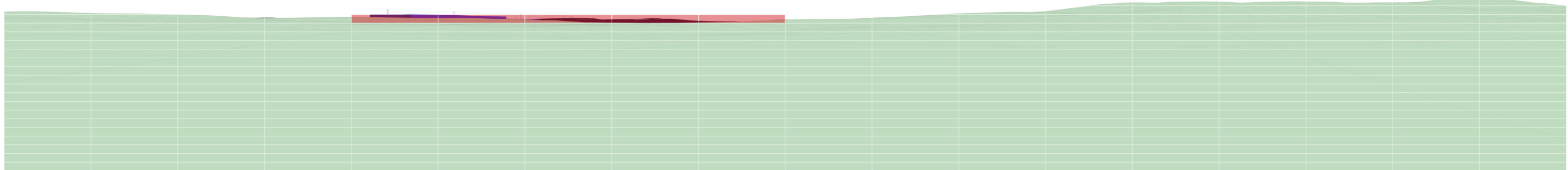
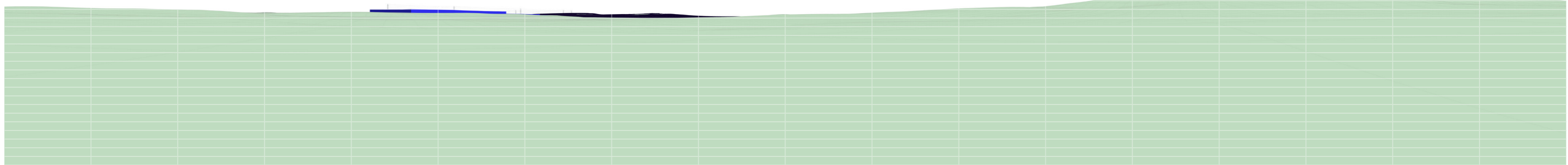



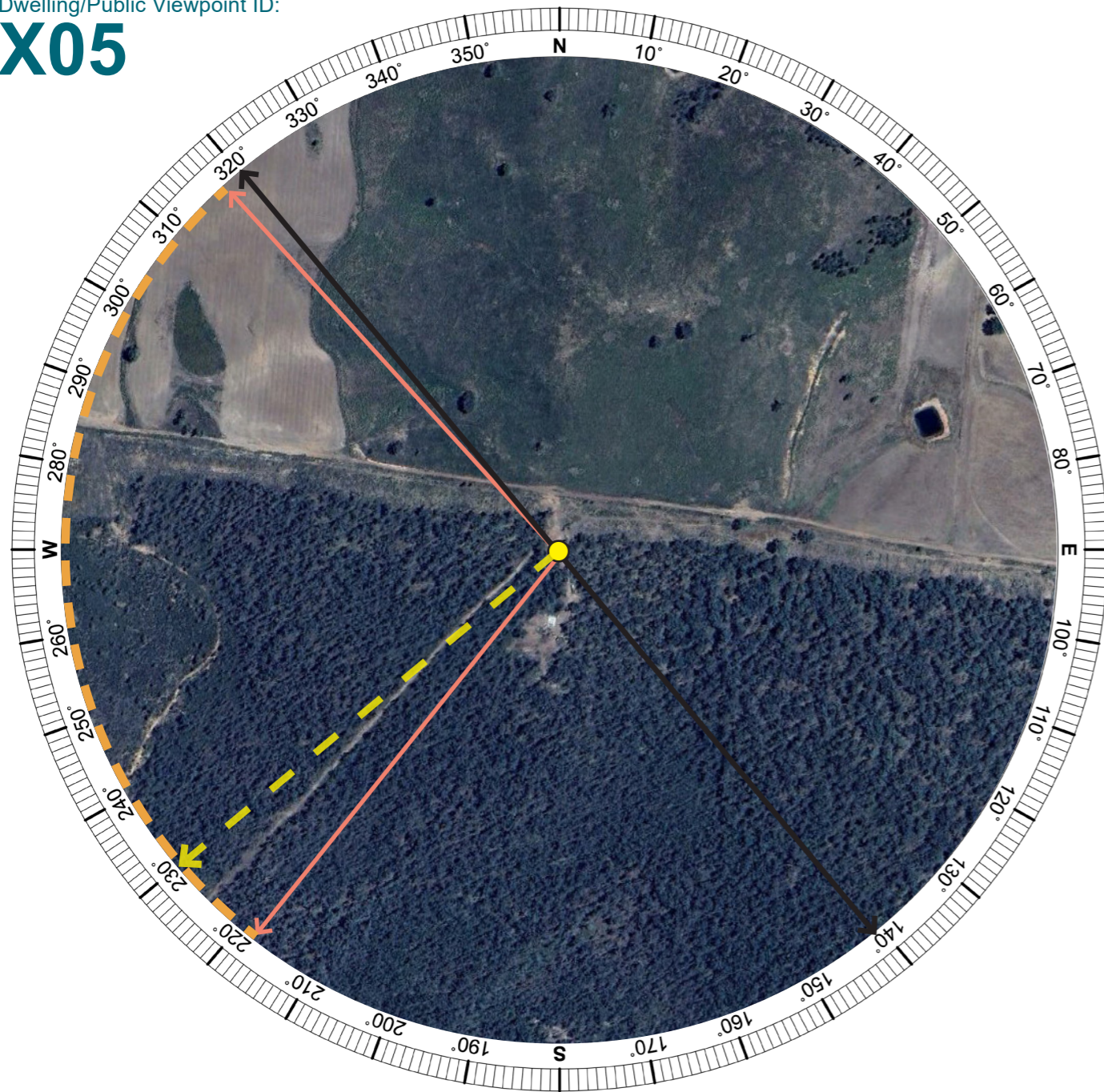

Dwelling/Public Viewpoint ID:

**X05**



**LEGEND**

-  Direction of potential visible Development Footprint (based on topography alone)
-  Extent of potential visible Development Footprint (based on topography alone)
-  Direction of the Wireframe
-  Extent of Panorama
-  Location of the viewpoint

Aerial Image - Wireframe Location (Aerial Image Source: Google Earth 2023)

**Residential Receptor X05**

Receptor Assessment:									
Coordinates	Distance to development:	Viewpoint Type:	Receptor Sensitivity:	Scenic Quality:	Overall Sensitivity:	Occupied Cells:	Magnitude Rating:	Preliminary Visual Impact Rating:	Site Visit Required?
32° 6'51.14"S 149°14'18.88"E	0.71 km	Residential Receptor	Moderate	Low	Moderate	18	Moderate	Moderate	<b>YES</b> / NO

**OCCUPIED CELL COUNT (TRANSMISSION LINES)**  
 Occupied Cell (greater than 3 degrees height)  
*A cell is unoccupied if the transmission lines do not occupy more than three vertical degrees of view or 3 vertical cells.*

**OCCUPIED CELL COUNT (SOLAR FARM)**  
 Occupied Cell (greater than 25%)  
*A cell is unoccupied if elements of the project, including solar panels, battery energy systems, or other associated infrastructure do not occupy more than approximately 25% of a cell.*

**Further Assessment Required:**  
 **Yes**       **No**

X05  
Residential Receptor

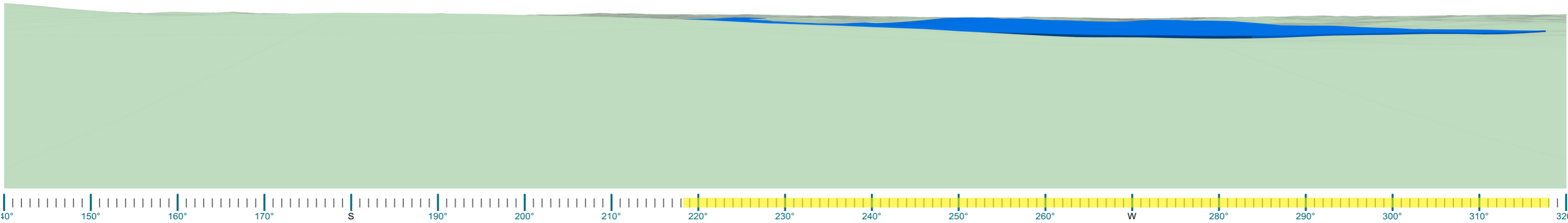

Extent of potentially visible solar panels (based on topography alone)

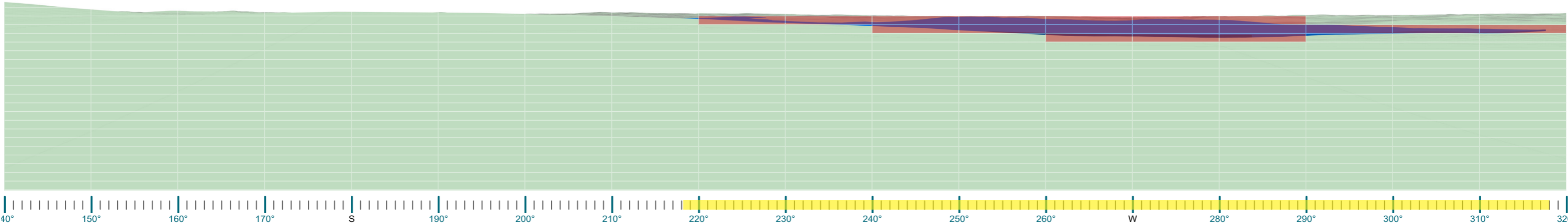
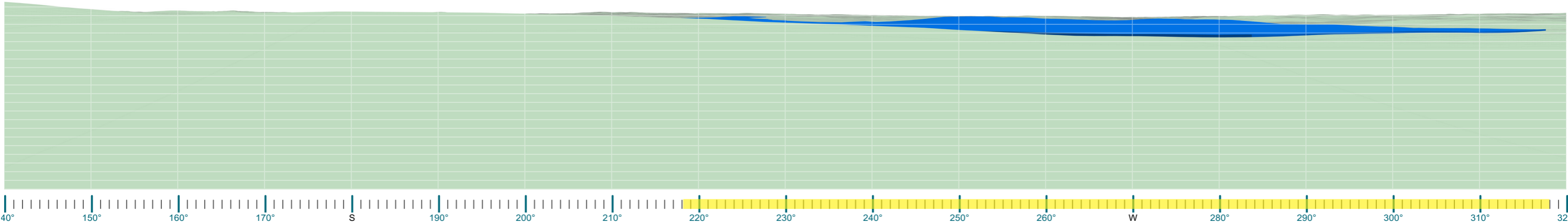

Dwelling/Public Viewpoint ID:  
**VP01**

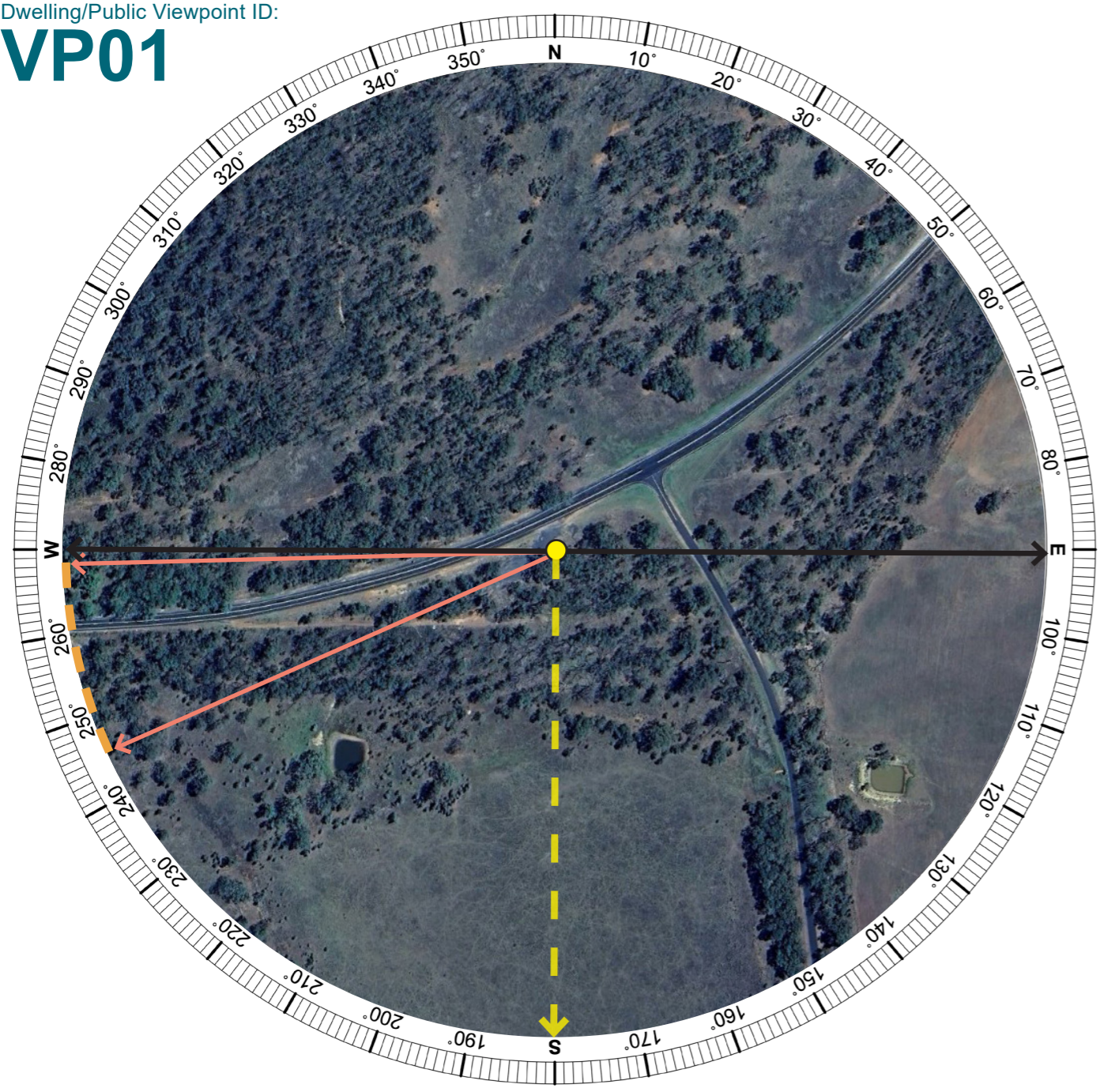

**LEGEND**

- Direction of potential visible Development Footprint (based on topography alone)
- Extent of potential visible Development Footprint (based on topography alone)
- Direction of the Wireframe
- Extent of Panorama
- Location of the viewpoint

Aerial Image - Wireframe Location (Aerial Image Source: Google Earth 2023)

**Public Receptor VP01**

Receptor Assessment:								
Coordinates	Distance to development:	Viewpoint Type:	Receptor Sensitivity:	Scenic Quality:	Overall Sensitivity:	Occupied Cells:	Magnitude Rating:	Preliminary Visual Impact Rating:
32°06'19.85"S 149°13'42.03"E	0.53 km	Public Receptor	Low	Low	Low	2	Very Low	Very Low

**OCCUPIED CELL COUNT (TRANSMISSION LINES)**

Occupied Cell (greater than 3 degrees height)

A cell is unoccupied if the transmission lines do not occupy more than three vertical degrees of view or 3 vertical cells.

**OCCUPIED CELL COUNT (SOLAR FARM)**

Occupied Cell (greater than 25%)

A cell is unoccupied if elements of the project, including solar panels, battery energy systems, or other associated infrastructure do not occupy more than approximately 25% of a cell.

Further Assessment Required:

Yes  No

VP01  
Public Receptor

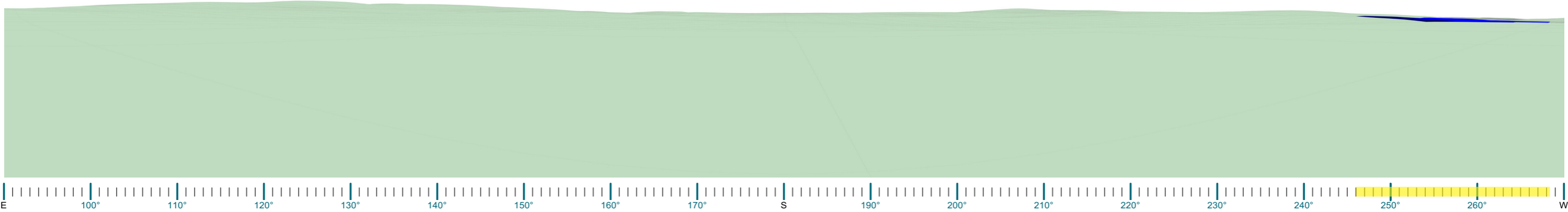

Extent of potentially visible solar panels (based on topography alone)

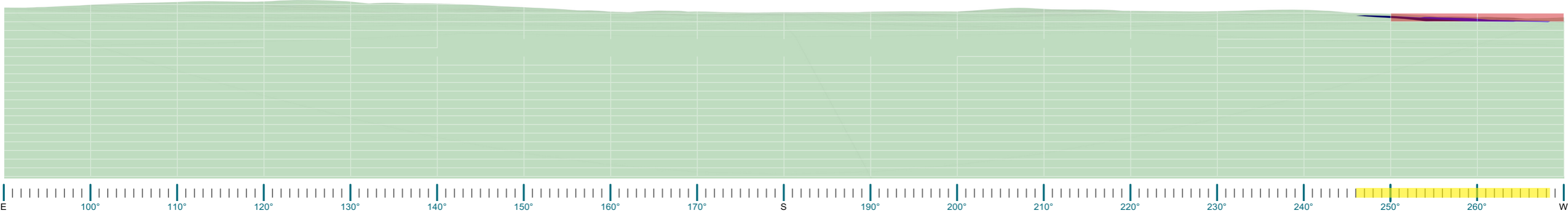
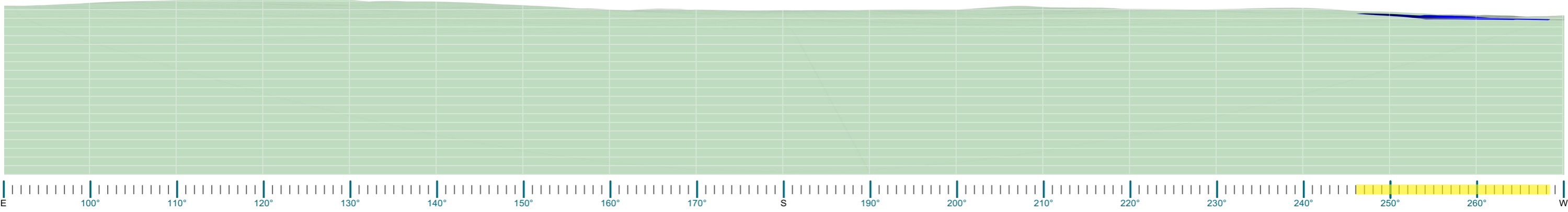

Dwelling/Public Viewpoint ID:

# VP03

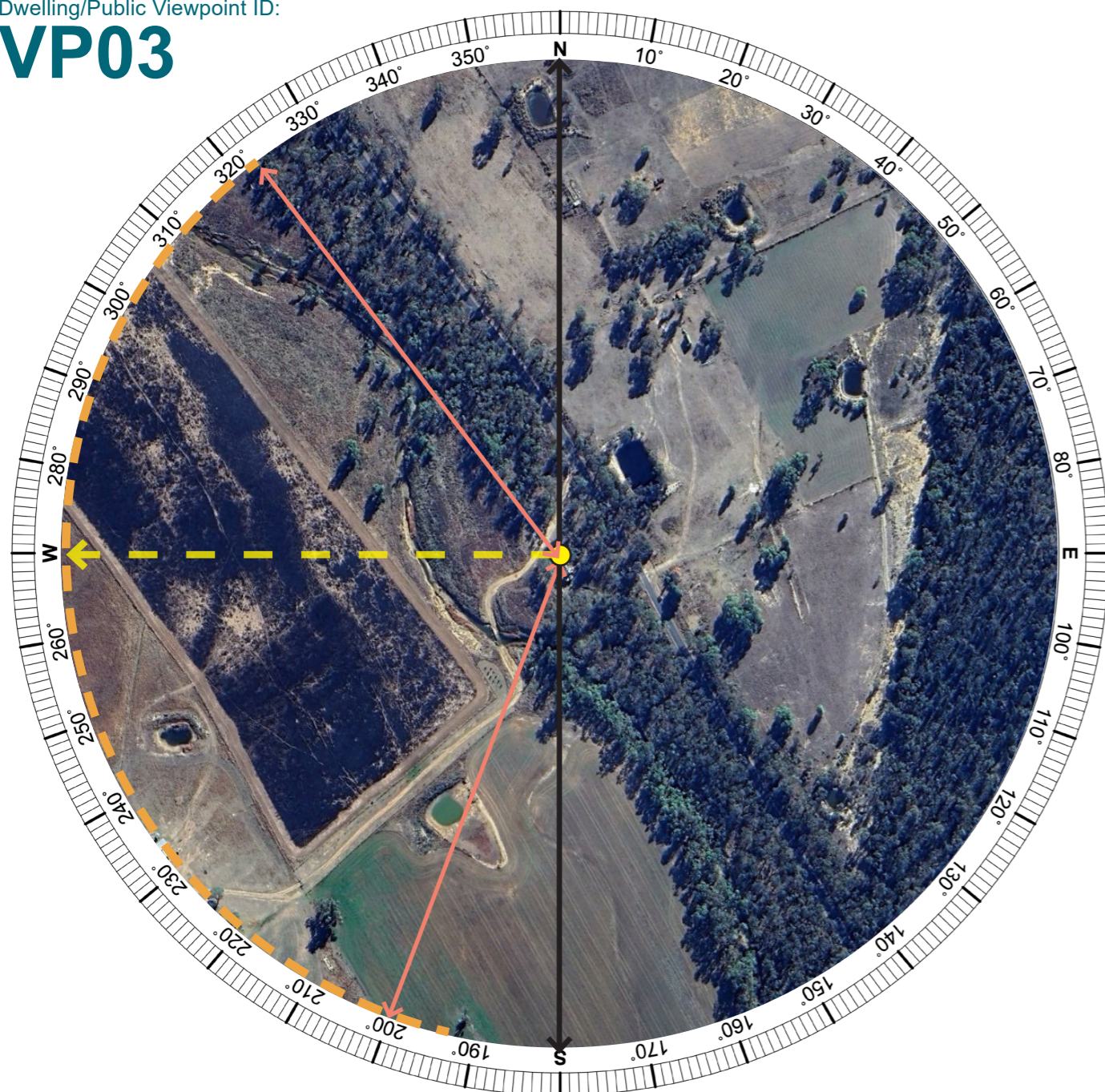

### LEGEND

- Direction of potential visible Development Footprint (based on topography alone)
- - Extent of potential visible Development Footprint (based on topography alone)
- - → Direction of the Wireframe
- ↔ Extent of Panorama
- Location of the viewpoint

Aerial Image - Wireframe Location (Aerial Image Source: Google Earth 2023)

## Public Receptor: VP03 (Rural Fire Station)

Receptor Assessment:								
Coordinates	Distance to development:	Viewpoint Type:	Receptor Sensitivity:	Scenic Quality:	Overall Sensitivity:	Occupied Cells:	Magnitude Rating:	Preliminary Visual Impact Rating:
32°10'47.33"S 149°15'38.68"E	0.13 km	Public Receptor	Low	Low	Low	36	High	Moderate

#### OCCUPIED CELL COUNT (TRANSMISSION LINES)

■ Occupied Cell (greater than 3 degrees height)

A cell is unoccupied if the transmission lines do not occupy more than three vertical degrees of view or 3 vertical cells.

#### OCCUPIED CELL COUNT (SOLAR FARM)

■ Occupied Cell (greater than 25%)

A cell is unoccupied if elements of the project, including solar panels, battery energy systems, or other associated infrastructure do not occupy more than approximately 25% of a cell.

### Further Assessment Required:



Yes

No

VP03 (Rural Fire Station)  
Public Receptor

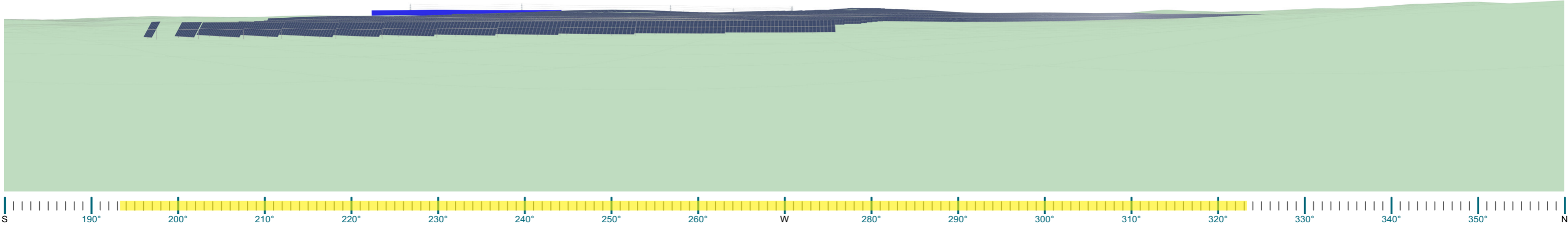

Extent of potentially visible solar panels (based on topography alone)

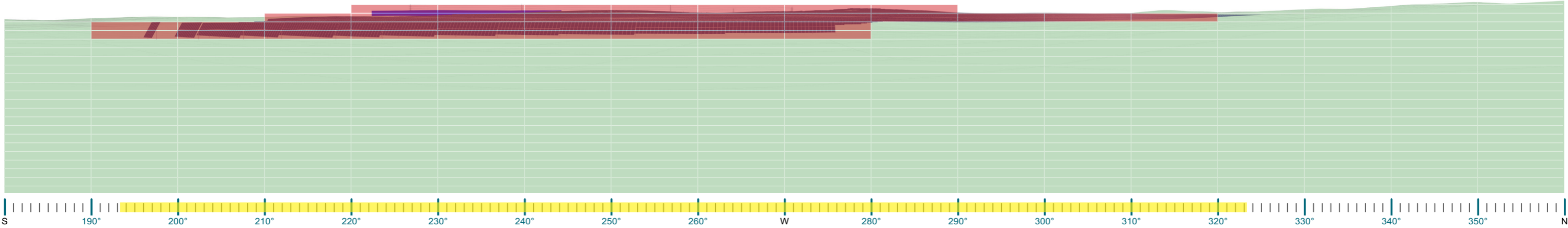
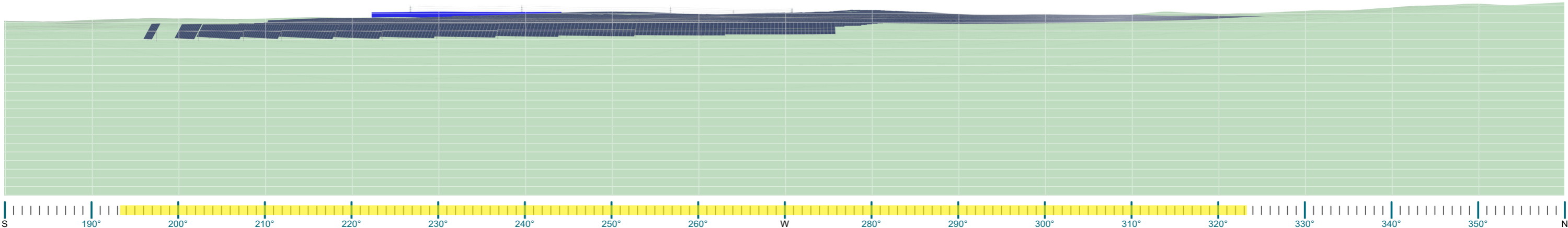

Dwelling/Public Viewpoint ID:  
**VP04**

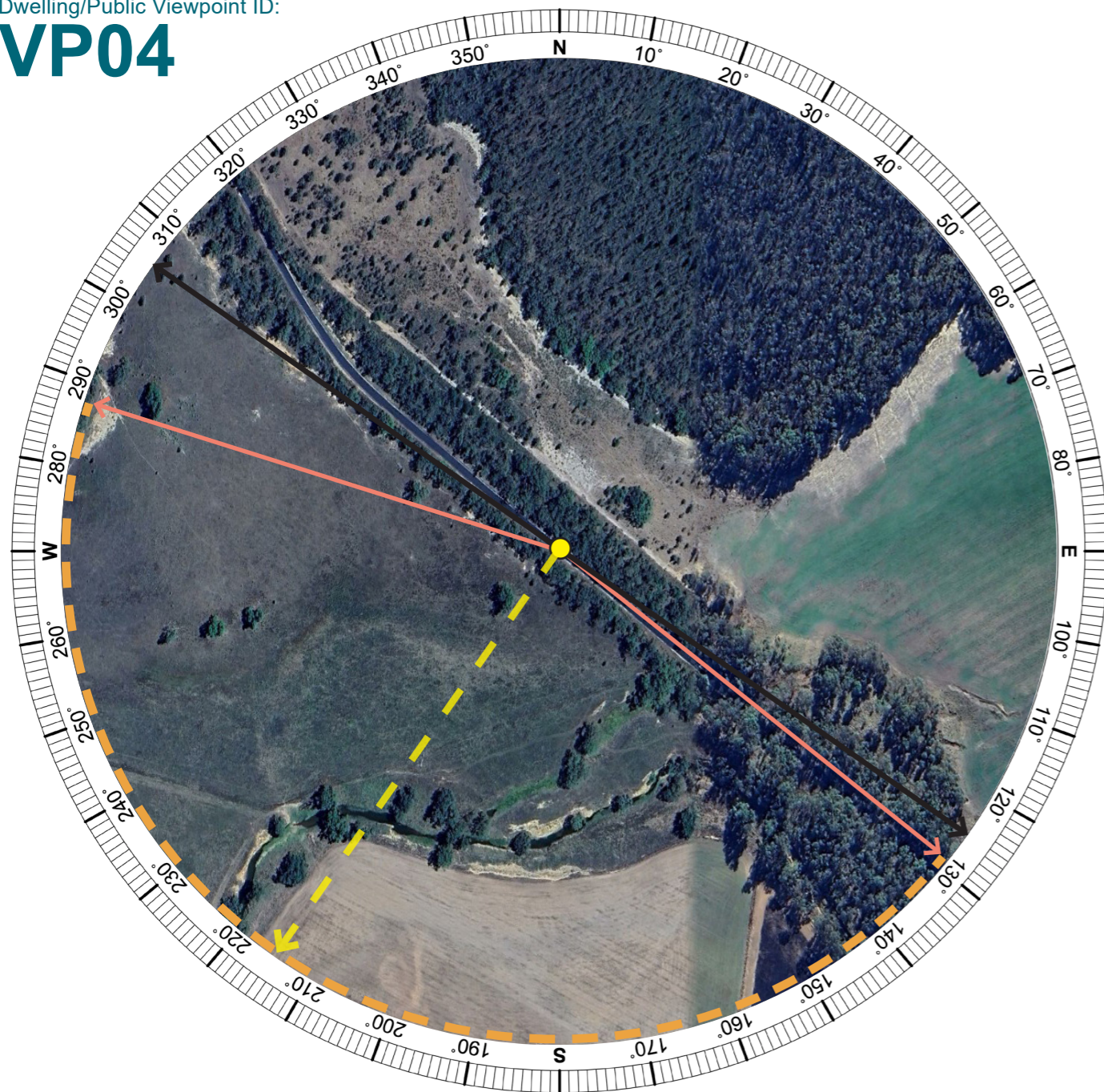

**LEGEND**

- Direction of potential visible Development Footprint (based on topography alone)
- Extent of potential visible Development Footprint (based on topography alone)
- Direction of the Wireframe
- Extent of Panorama
- Location of the viewpoint

Aerial Image - Wireframe Location (Aerial Image Source: Google Earth 2023)

Public Receptor VP04								
Receptor Assessment:								
Coordinates	Distance to development:	Viewpoint Type:	Receptor Sensitivity:	Scenic Quality:	Overall Sensitivity:	Occupied Cells:	Magnitude Rating:	Preliminary Visual Impact Rating:
32°09'55.25"S 149°14'42.09"E	0.29 km	Public Receptor	Low	Low	Low	31	High	Moderate

**OCCUPIED CELL COUNT (TRANSMISSION LINES)**  
 Occupied Cell (greater than 3 degrees height)  
A cell is unoccupied if the transmission lines do not occupy more than three vertical degrees of view or 3 vertical cells.

**OCCUPIED CELL COUNT (SOLAR FARM)**  
 Occupied Cell (greater than 25%)  
A cell is unoccupied if elements of the project, including solar panels, battery energy systems, or other associated infrastructure do not occupy more than approximately 25% of a cell.

Further Assessment Required:

Yes  No

VP04  
Public Receptor

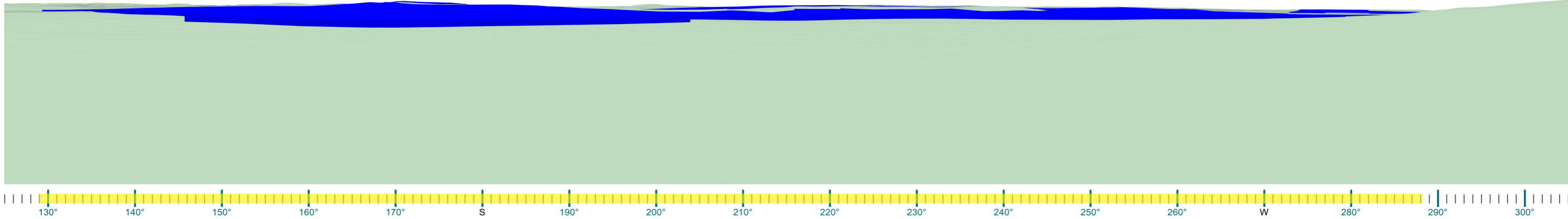

Extent of potentially visible solar panels (based on topography alone)

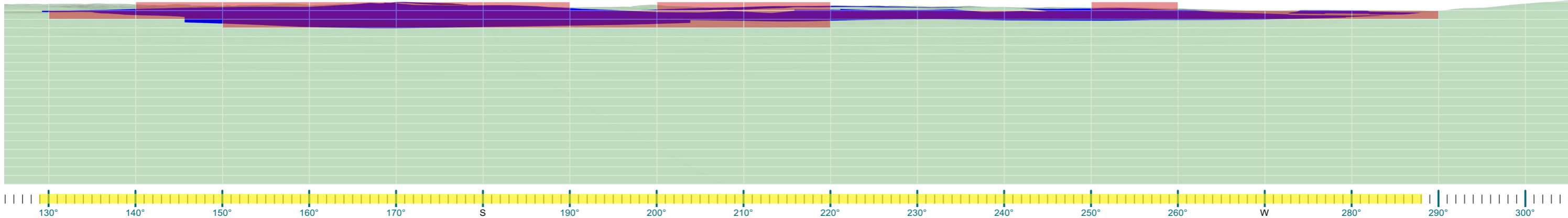
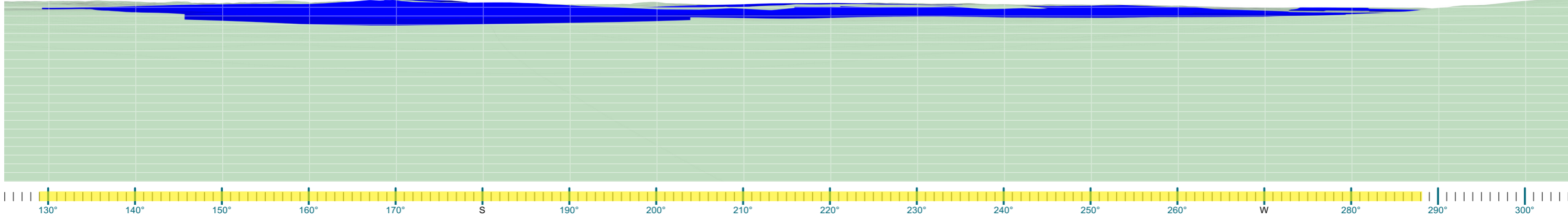

Dwelling/Public Viewpoint ID:  
**VP05**

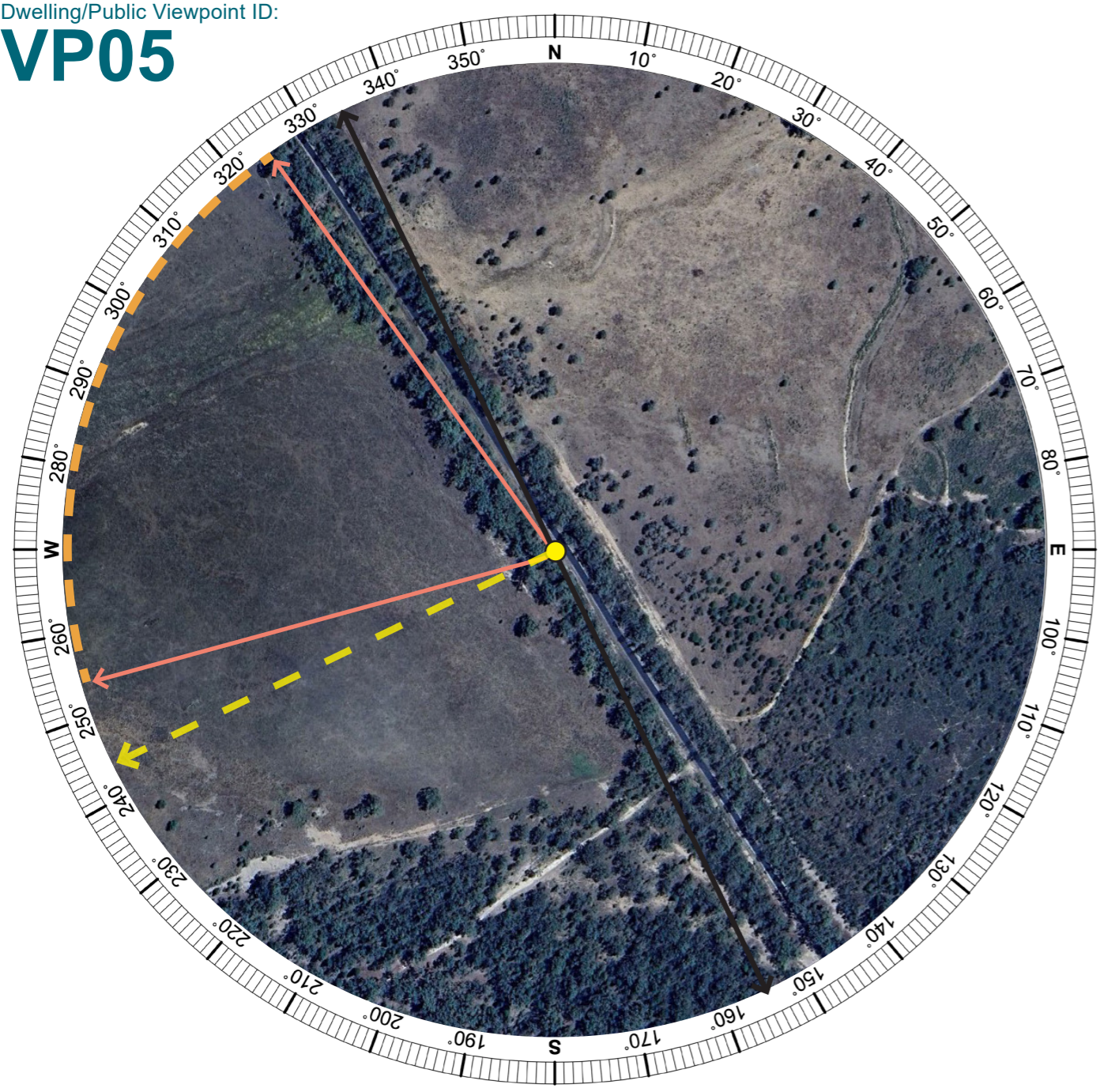

**LEGEND**

- Direction of potential visible Development Footprint (based on topography alone)
- Extent of potential visible Development Footprint (based on topography alone)
- Direction of the Wireframe
- Extent of Panorama
- Location of the viewpoint

Aerial Image - Wireframe Location (Aerial Image Source: Google Earth 2023)

**Public Receptor VP05**

Receptor Assessment:								
Coordinates	Distance to development:	Viewpoint Type:	Receptor Sensitivity:	Scenic Quality:	Overall Sensitivity:	Occupied Cells:	Magnitude Rating:	Preliminary Visual Impact Rating:
32°09'06.39"S 149°14'0.51"E	0.21 km	Public Receptor	Low	Low	Low	17	Moderate	Low

**OCCUPIED CELL COUNT (TRANSMISSION LINES)**

Occupied Cell (greater than 3 degrees height)

A cell is unoccupied if the transmission lines do not occupy more than three vertical degrees of view or 3 vertical cells.

**OCCUPIED CELL COUNT (SOLAR FARM)**

Occupied Cell (greater than 25%)

A cell is unoccupied if elements of the project, including solar panels, battery energy systems, or other associated infrastructure do not occupy more than approximately 25% of a cell.

Further Assessment Required:

Yes  No

VP05  
Public Receptor

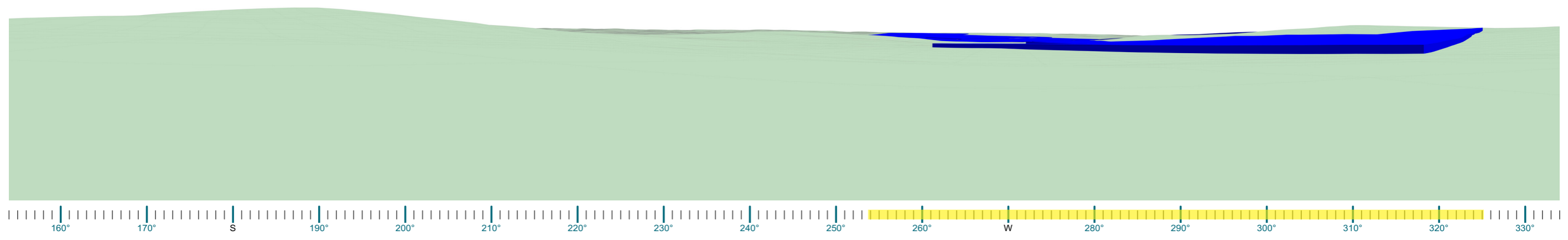

← Extent of potentially visible solar panels (based on topography alone) →

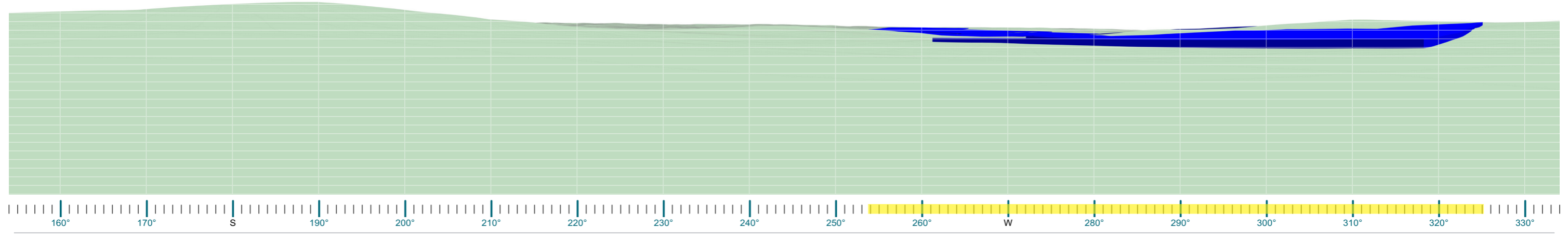
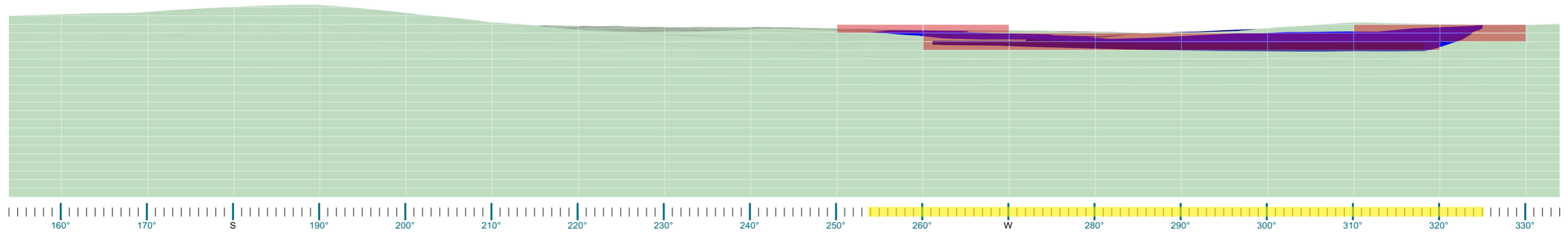

Dwelling/Public Viewpoint ID:  
**VP06**

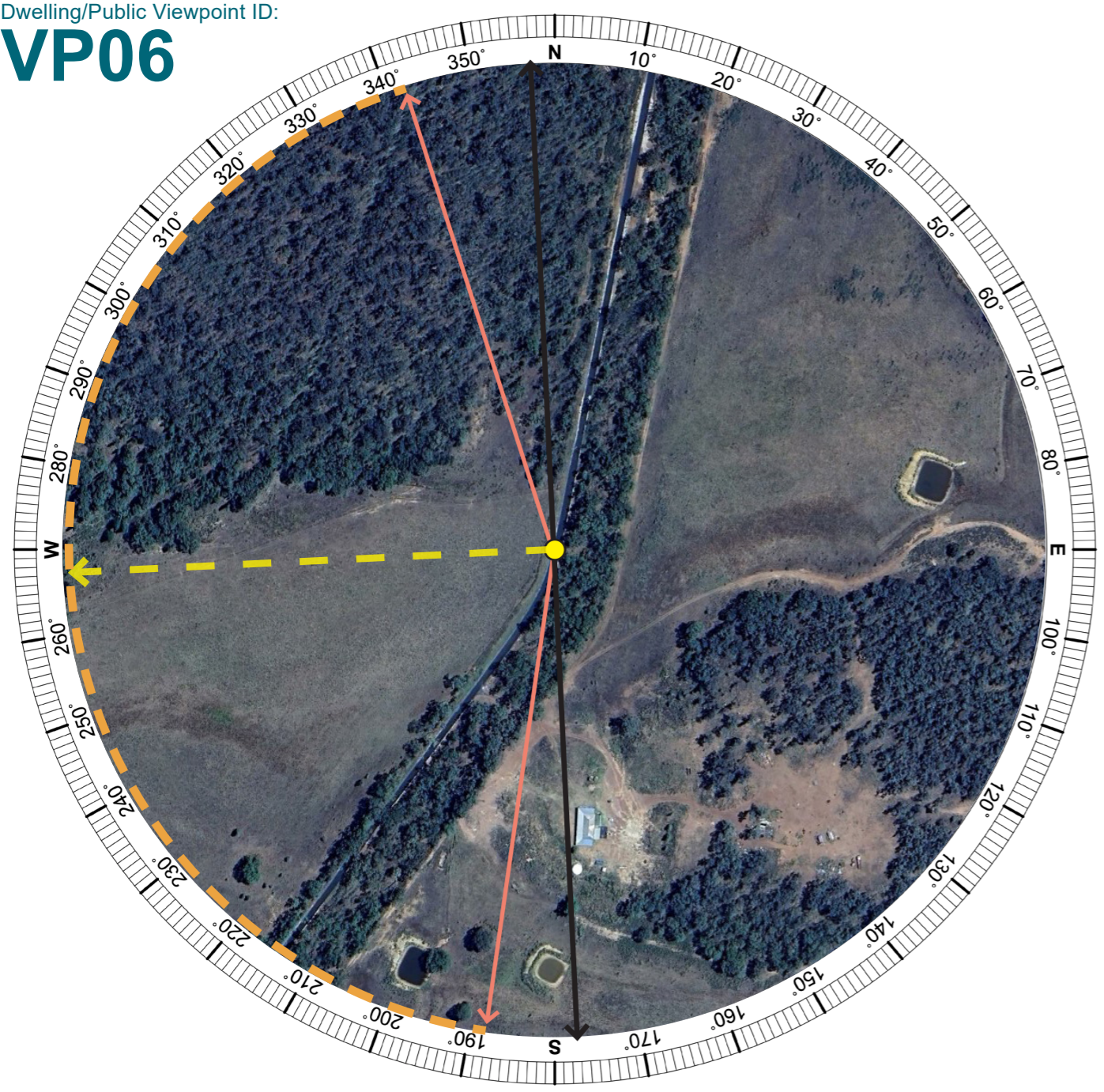

**LEGEND**

- Direction of potential visible Development Footprint (based on topography alone)
- - - Extent of potential visible Development Footprint (based on topography alone)
- Direction of the Wireframe
- ↔ Extent of Panorama
- Location of the viewpoint

Aerial Image - Wireframe Location (Aerial Image Source: Google Earth 2023)

**Public Receptor VP06**

Receptor Assessment:								
Coordinates	Distance to development:	Viewpoint Type:	Receptor Sensitivity:	Scenic Quality:	Overall Sensitivity:	Occupied Cells:	Magnitude Rating:	Preliminary Visual Impact Rating:
32°07'28.96"S 149°13'47.12"E	0.02 km	Public Receptor	Low	Low	Low	77	Very High	Moderate

**OCCUPIED CELL COUNT (TRANSMISSION LINES)**  
■ Occupied Cell (greater than 3 degrees height)  
A cell is unoccupied if the transmission lines do not occupy more than three vertical degrees of view or 3 vertical cells.

**OCCUPIED CELL COUNT (SOLAR FARM)**  
■ Occupied Cell (greater than 25%)  
A cell is unoccupied if elements of the project, including solar panels, battery energy systems, or other associated infrastructure do not occupy more than approximately 25% of a cell.

Further Assessment Required:

Yes  No

VP06  
Public Receptor

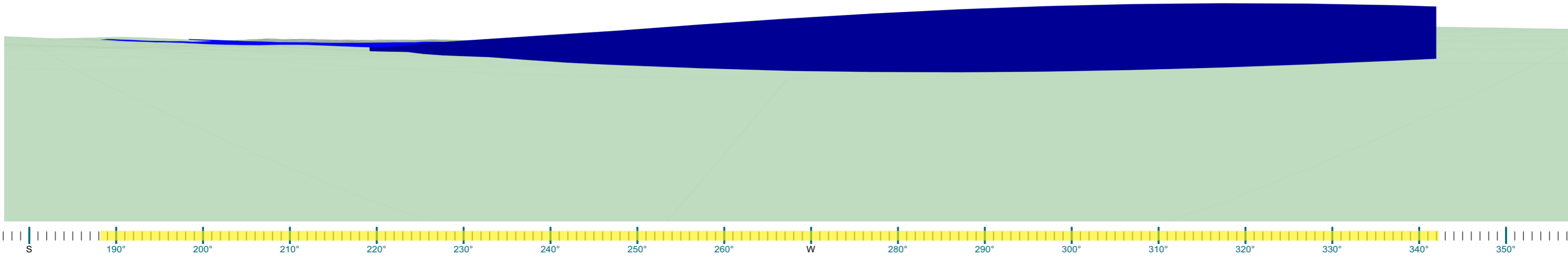

Extent of potentially visible solar panels (based on topography alone)

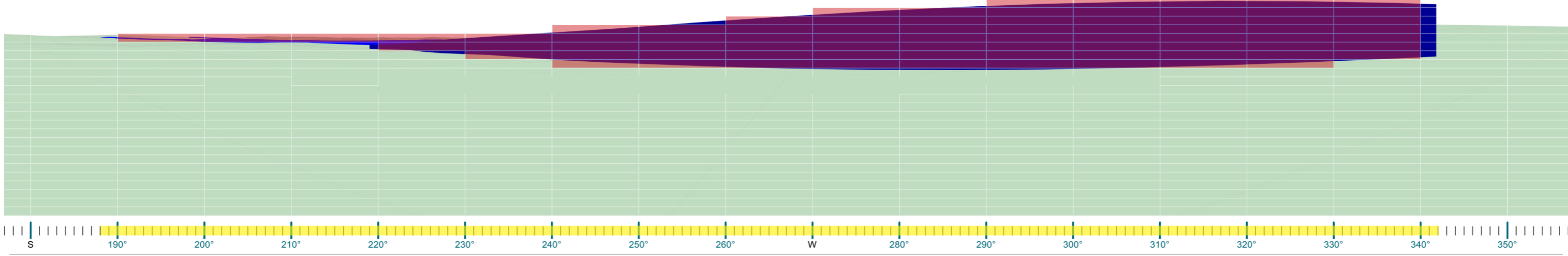
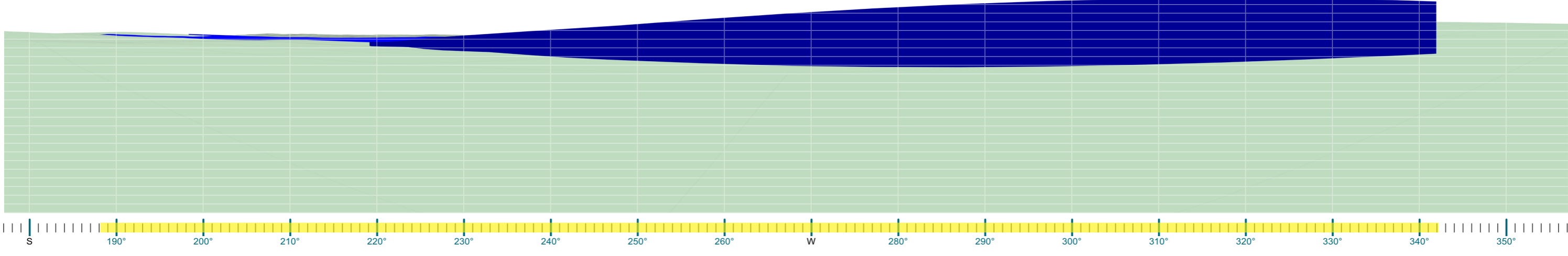

Dwelling/Public Viewpoint ID:  
**VP07**

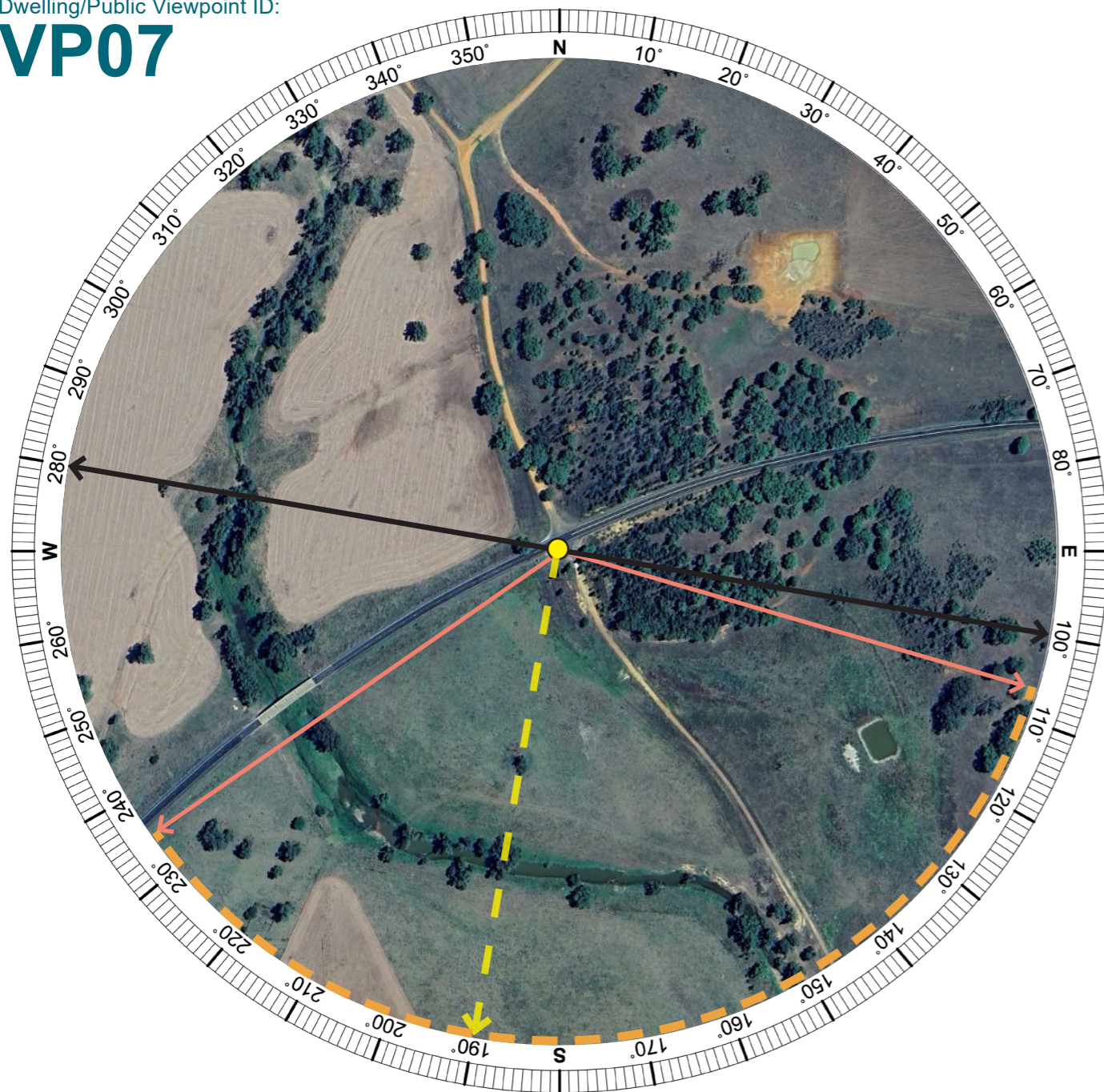

**LEGEND**

- Direction of potential visible Development Footprint (based on topography alone)
- Extent of potential visible Development Footprint (based on topography alone)
- Direction of the Wireframe
- Extent of Panorama
- Location of the viewpoint

Aerial Image - Wireframe Location (Aerial Image Source: Google Earth 2023)

Public Receptor VP07								
Receptor Assessment:								
Coordinates	Distance to development:	Viewpoint Type:	Receptor Sensitivity:	Scenic Quality:	Overall Sensitivity:	Occupied Cells:	Magnitude Rating:	Preliminary Visual Impact Rating:
32°06'25.46"S 149°11'46.11"E	0.33 km	Public Receptor	Low	Low	Low	13	Moderate	Low

**OCCUPIED CELL COUNT (TRANSMISSION LINES)**

Occupied Cell (greater than 3 degrees height)

A cell is unoccupied if the transmission lines do not occupy more than three vertical degrees of view or 3 vertical cells.

**OCCUPIED CELL COUNT (SOLAR FARM)**

Occupied Cell (greater than 25%)

A cell is unoccupied if elements of the project, including solar panels, battery energy systems, or other associated infrastructure do not occupy more than approximately 25% of a cell.

Further Assessment Required:

Yes  No

VP07  
Public Receptor

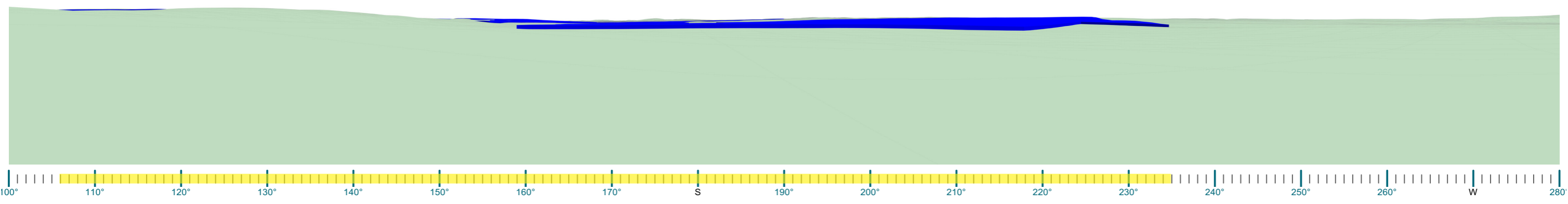

Extent of potentially visible solar panels (based on topography alone)

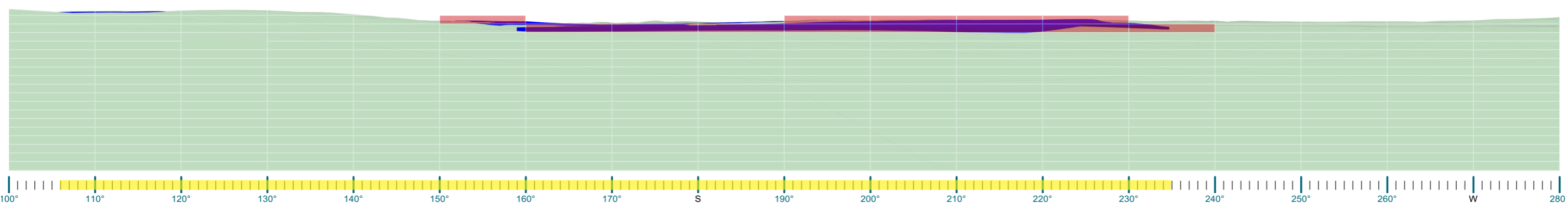
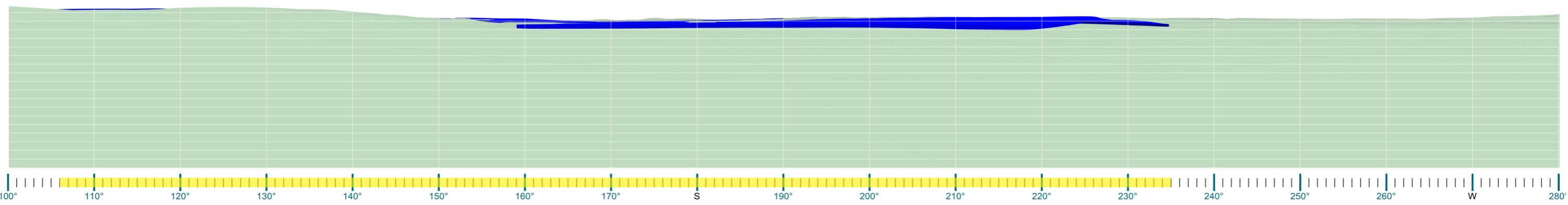



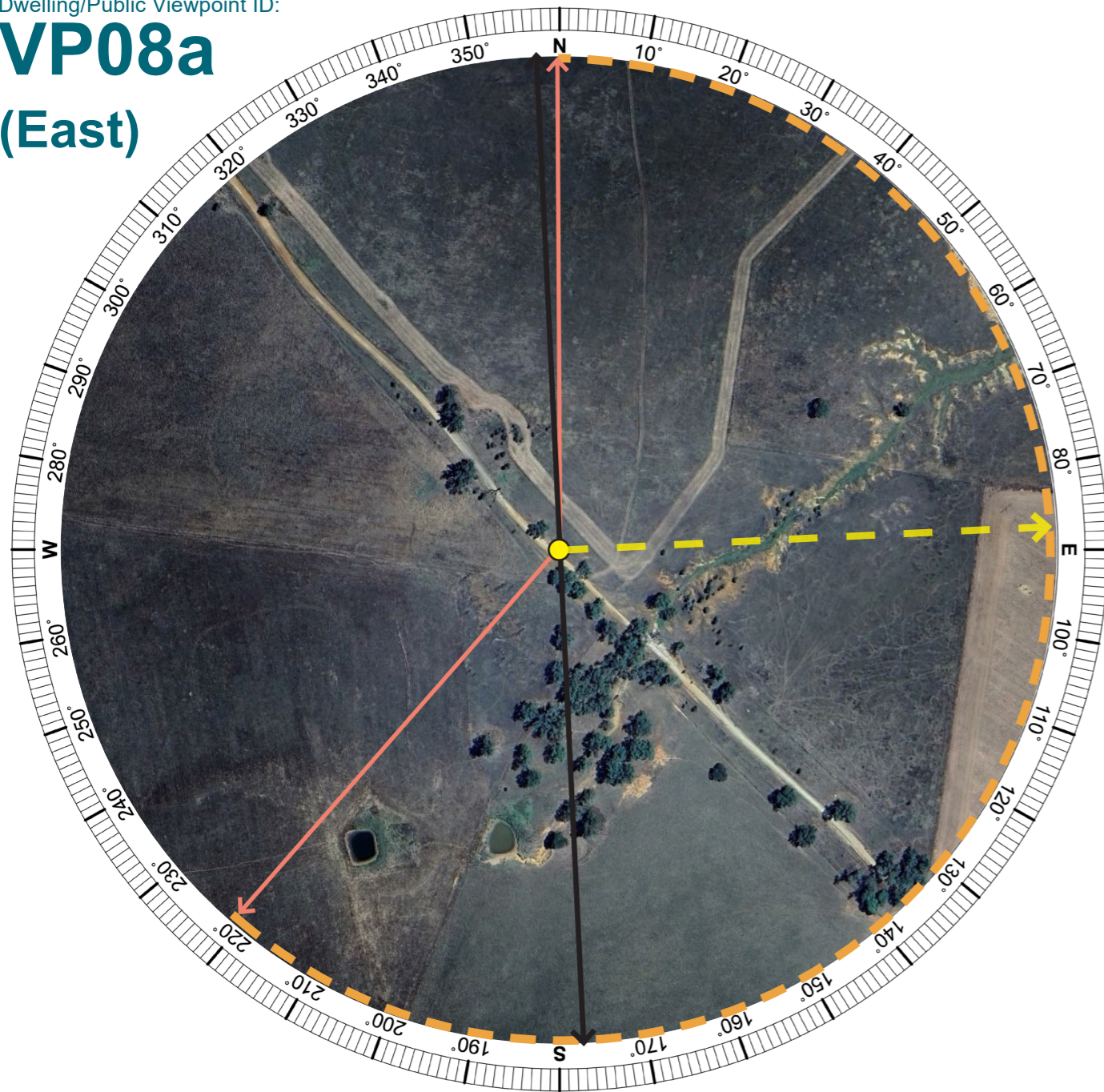

Dwelling/Public Viewpoint ID:

# VP08a (East)



### LEGEND

-  Direction of potential visible Development Footprint (based on topography alone)
-  Extent of potential visible Development Footprint (based on topography alone)
-  Direction of the Wireframe
-  Extent of Panorama
-  Location of the viewpoint

Aerial Image - Wireframe Location (Aerial Image Source: Google Earth 2023)

#### OCCUPIED CELL COUNT (TRANSMISSION LINES)

 Occupied Cell (greater than 3 degrees height)

A cell is unoccupied if the transmission lines do not occupy more than three vertical degrees of view or 3 vertical cells.

#### OCCUPIED CELL COUNT

 Occupied Cell (greater than 25%)

A cell is unoccupied if elements of the project, including solar panels, battery energy systems, or other associated infrastructure do not occupy more than approximately 25% of a cell.

VP08a (East)  
Public Receptor

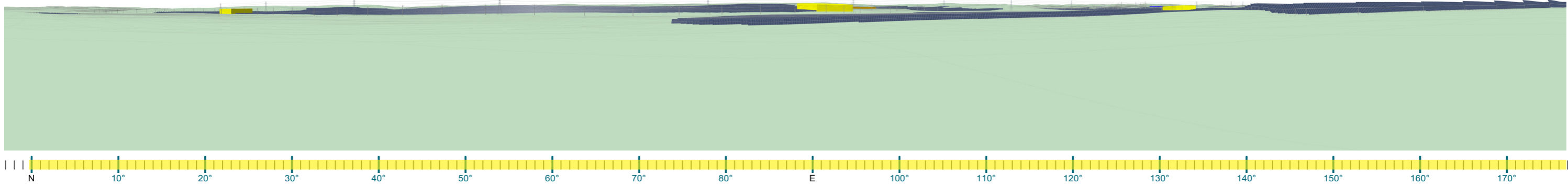

Extent of potentially visible solar panels (based on topography alone)

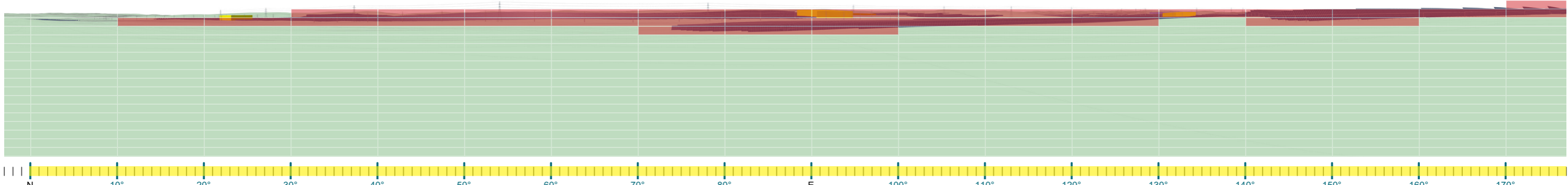
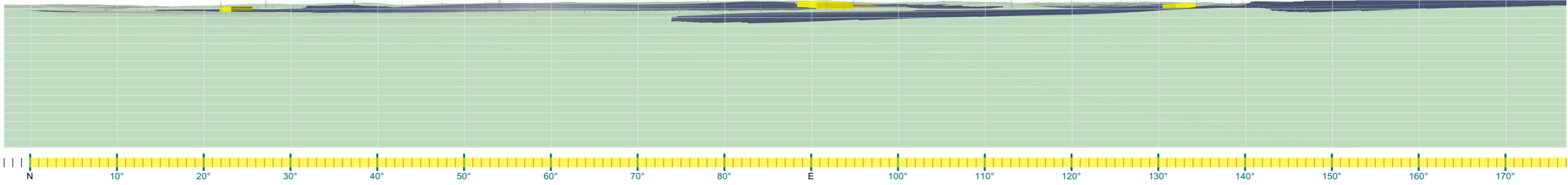

Dwelling/Public Viewpoint ID:

# VP08b (West)

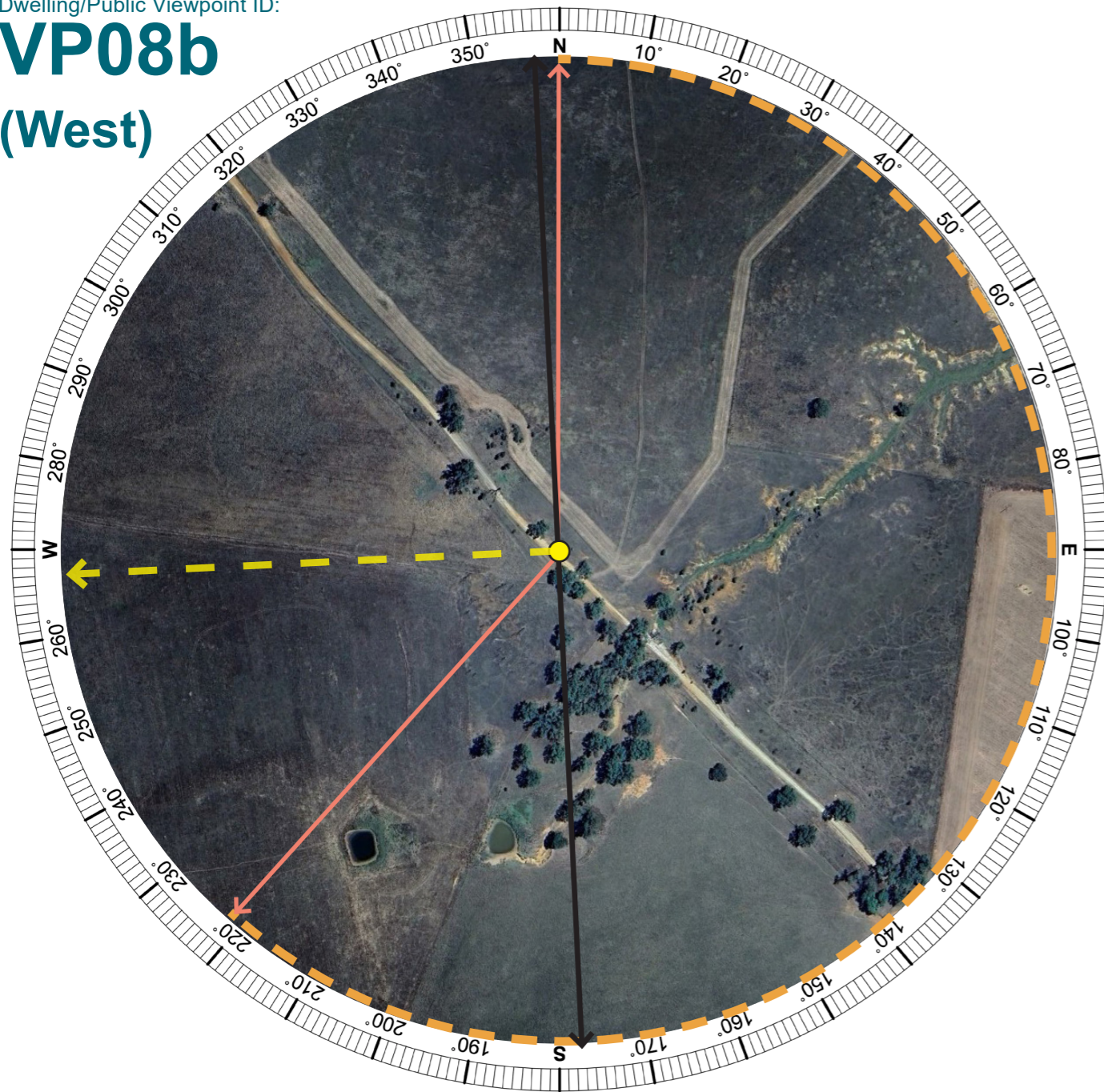

### LEGEND

- Direction of potential visible Development Footprint (based on topography alone)
- Extent of potential visible Development Footprint (based on topography alone)
- Direction of the Wireframe
- Extent of Panorama
- Location of the viewpoint

Aerial Image - Wireframe Location (Aerial Image Source: Google Earth 2023)

## Public Receptor VP08 (East & West)

Receptor Assessment:								
Coordinates	Distance to development:	Viewpoint Type:	Receptor Sensitivity:	Scenic Quality:	Overall Sensitivity:	Occupied Cells:	Magnitude Rating:	Preliminary Visual Impact Rating:
32°08'51.84"S 149°11'36.20"E	0.16 km	Public Receptor	Low	Low	Low	37	Very High	Moderate

**OCCUPIED CELL COUNT (TRANSMISSION LINES)**

Occupied Cell (greater than 3 degrees height)

A cell is unoccupied if the transmission lines do not occupy more than three vertical degrees of view or 3 vertical cells.

**OCCUPIED CELL COUNT (SOLAR FARM)**

Occupied Cell (greater than 25%)

A cell is unoccupied if elements of the project, including solar panels, battery energy systems, or other associated infrastructure do not occupy more than approximately 25% of a cell.

**Further Assessment Required:**

Yes  No

VP08b (West)  
Public Receptor

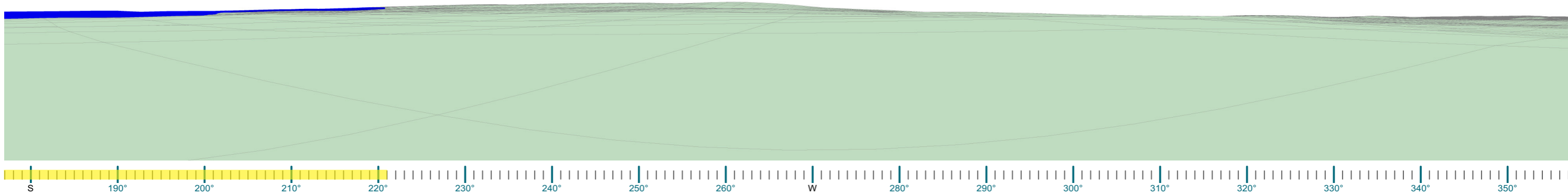

Extent of potentially visible solar panels  
(based on topography alone)

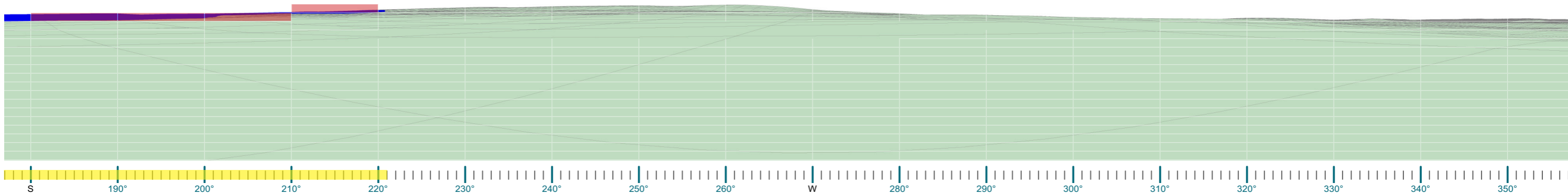
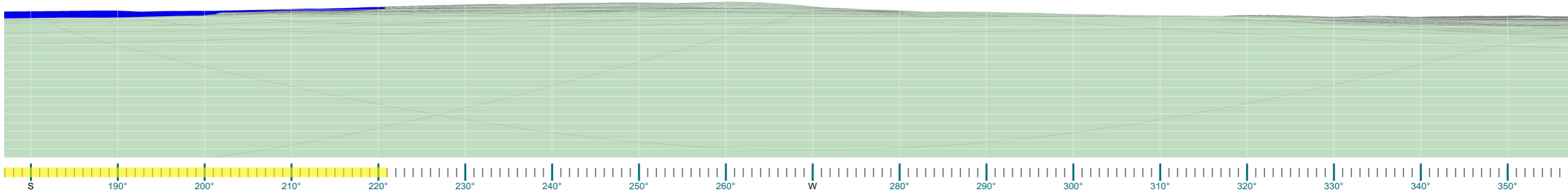

Dwelling/Public Viewpoint ID:

# VP13

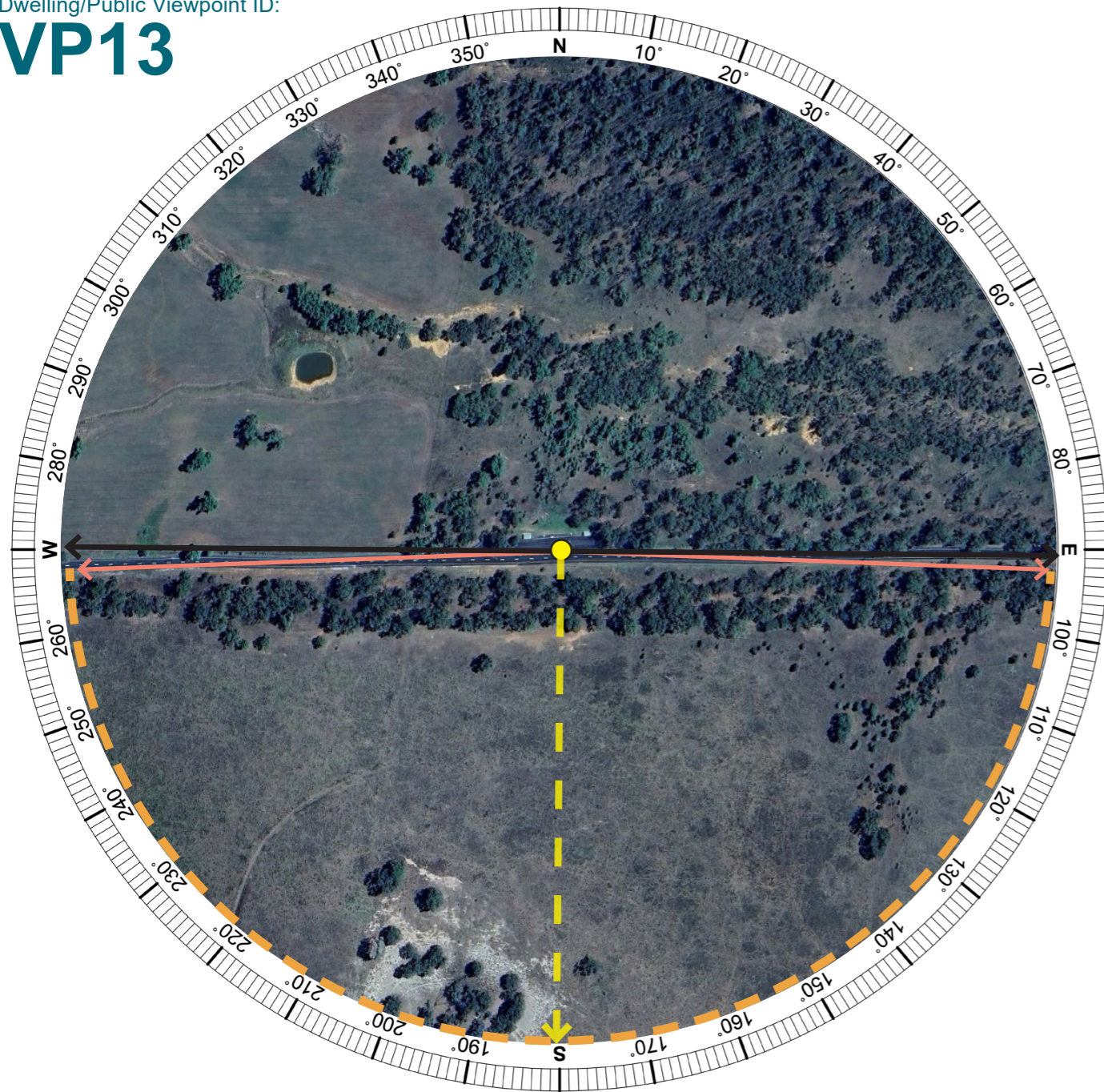

### LEGEND

- Direction of potential visible Development Footprint (based on topography alone)
- Extent of potential visible Development Footprint (based on topography alone)
- Direction of the Wireframe
- Extent of Panorama
- Location of the viewpoint

Aerial Image - Wireframe Location (Aerial Image Source: Google Earth 2023)

## Public Receptor: VP13 (Golden Highway Rest Stop)

Receptor Assessment:								
Coordinates	Distance to development:	Viewpoint Type:	Receptor Sensitivity:	Scenic Quality:	Overall Sensitivity:	Occupied Cells:	Magnitude Rating:	Preliminary Visual Impact Rating:
32°06'21.24"S 149°12'37.50"E	0.06 km	Public Receptor	Low	Low	Low	62	Very High	Moderate

**OCCUPIED CELL COUNT (TRANSMISSION LINES)**

Occupied Cell (greater than 3 degrees height)

A cell is unoccupied if the transmission lines do not occupy more than three vertical degrees of view or 3 vertical cells.

**OCCUPIED CELL COUNT (SOLAR FARM)**

Occupied Cell (greater than 25%)

A cell is unoccupied if elements of the project, including solar panels, battery energy systems, or other associated infrastructure do not occupy more than approximately 25% of a cell.

### Further Assessment Required:

Yes  No

VP13 (Golden Highway Rest Stop)  
Public Receptor

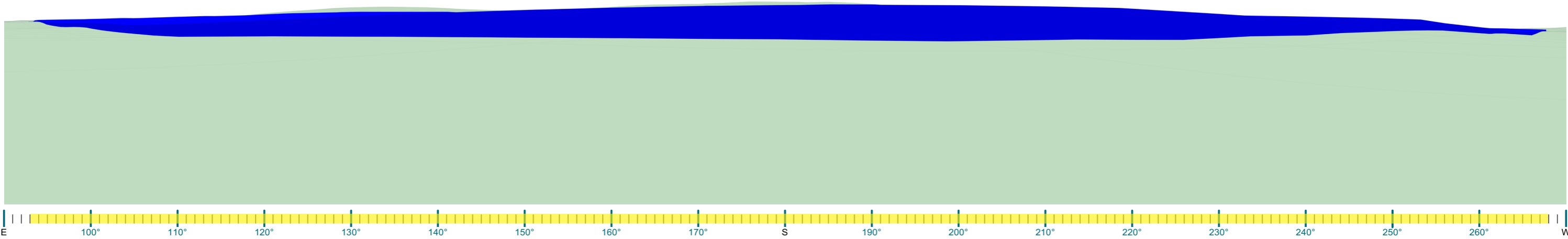

Extent of potentially visible solar panels (based on topography alone)

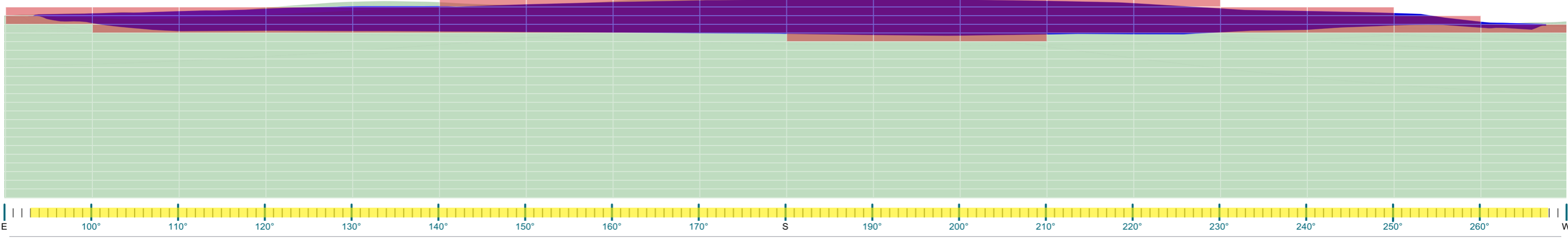
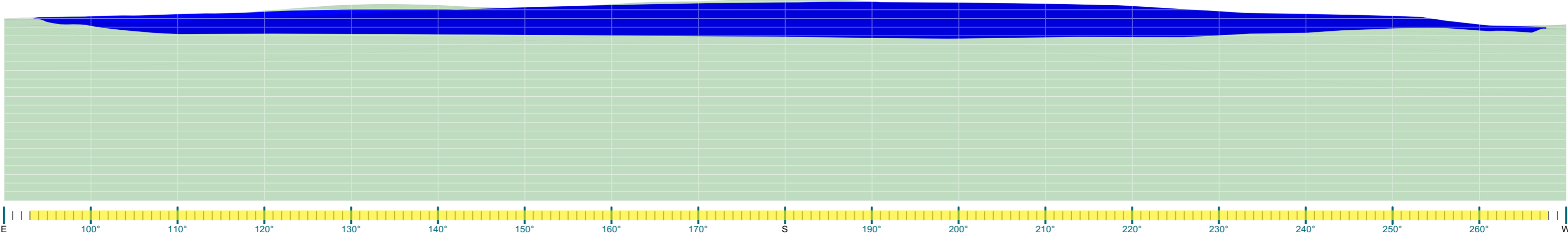



# 2 Detailed Assessment (Photomontages)

# Detailed Assessment - Photomontage Locations

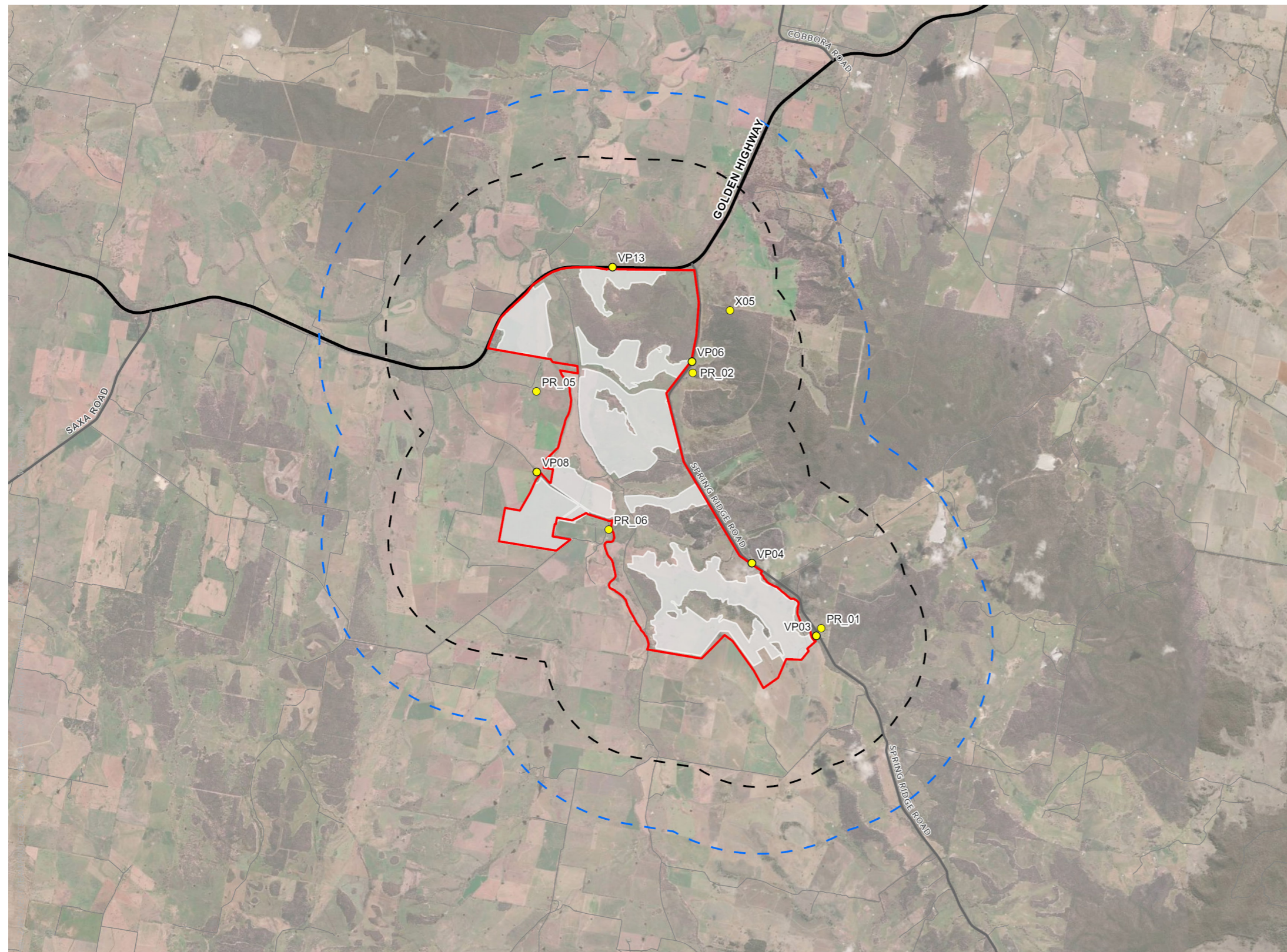

## LEGEND

- Project Boundary
- PV Array Area for Assessment
- Public & Railway Receptors Study Area (2.5 km from Solar Array Area)
- Sensitive Private Receptors Study Area (4.0 km from Solar Array Area)
- Highway
- Roads
- Unsealed Roads
- Photomontage Locations

**Figure 02** – Photomontage Locations  
Basemap Source: ESRI, 2024

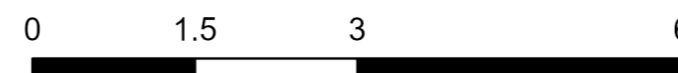

# Detailed Assessment Methodology (Photomontages)

## Phase 2 - Detailed Assessment (Photomontages)

After undertaking Step 1 detailed assessment using wireframes, three (3) non-associated residences and one (1) public viewpoints require further detailed assessment using photomontages. The process for generating the photomontages involves computer generation of a wireframe perspective view of the Project and topography, then superimposing a scaled panoramic 50 mm image overlay captured during onsite inspections.



### Step 1 - Determine Visual Sensitivity

The visual sensitivity is determined by identifying the sensitivity of the individual receiver and categorising the scenic quality of the area in view (refer to the LVIA for an assessment of the existing landscape character).

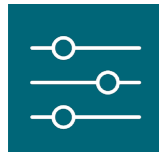

### Step 2 - Determine Visual Magnitude

Visual magnitude is determined by analysing the volume of the field of view that a project would occupy. This can be determined by splitting the wire frame diagram into a grid comprising cells 1 degree high and 10 degrees wide and counting the number of cells that would be occupied by a Project. As per the Guideline, 'a cell is unoccupied if elements of the project, including solar panels, battery energy systems, or other associated infrastructure do not occupy more than approximately 25% of a cell'. The detailed assessment using photomontages allows us to ascertain any existing screen factors such as vegetation or structures, which reduces the degree of visibility and therefore number of occupied cells.

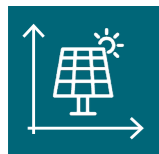

### Step 3 - Determine Visual Impact Rating

The overall visual impact rating of each viewpoint must be determined for each assessable viewpoint by combining the visual magnitude and visual sensitivity using the matrix adjacent.

Visual Magnitude (Number of Occupied Cells)	Visual Sensitivity			
	High	Moderate	Low	Very Low
Very High 37+	High	High	Moderate	Moderate
High 26 - 36	High	Moderate	Moderate	Low
Moderate 15 - 25	Moderate	Moderate	Low	Low
Low 8 - 14	Moderate	Low	Low	Very Low
Very Low 1 - 7	Low	Low	Very Low	Very Low

### Performance Objectives Required:

Yes	No
-----	----

Any viewpoint locations still resulting in a moderate or high visual impact are assessed against the performance objectives, and mitigation strategies should be considered to reduce the visual impacts to an acceptable level outlined in the performance objectives.

Dwelling/Public Viewpoint ID:

**PR\_1**

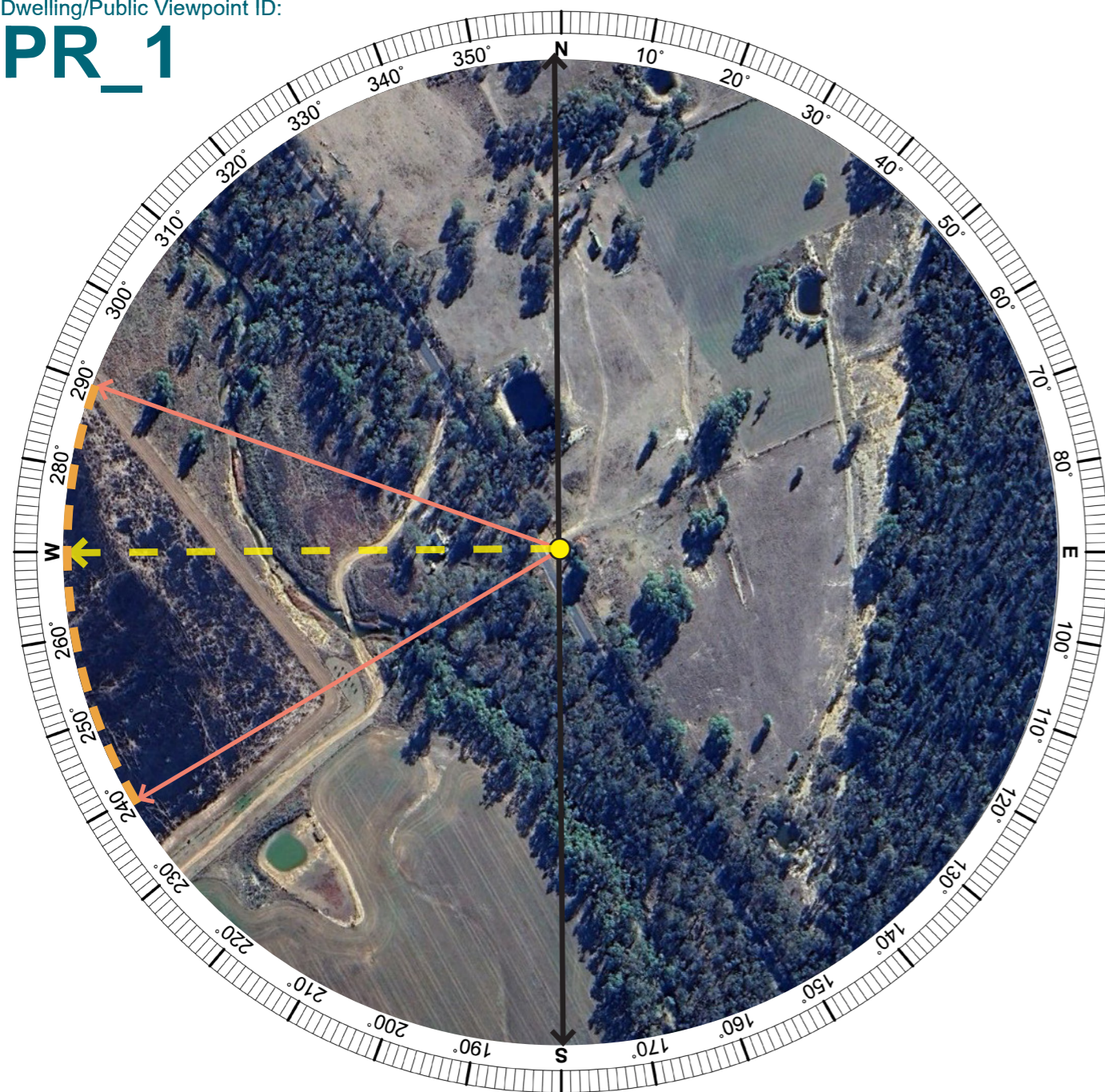

**LEGEND**

- Direction of potential visible Development Footprint
- Extent of potential visible Development Footprint
- Direction of the Wireframe
- Extent of Panorama
- Location of the viewpoint

Aerial Image - Wireframe Location (Aerial Image Source: Google Earth 2023)

**Residential Receptor PR\_1**

Receptor Assessment:								
Coordinates	Distance to development:	Viewpoint Type:	Receptor Sensitivity:	Scenic Quality:	Overall Sensitivity:	Occupied Cells:	Magnitude Rating:	Preliminary Visual Impact Rating:
32°10'41.57"S 149°15'42.95"E	0.26 km	Residential Receptor	Moderate	Moderate	Moderate	6	Very Low	Low

**OCCUPIED CELL COUNT**  
 Occupied Cell (greater than 25%)  
A cell is unoccupied if elements of the project, including solar panels, battery energy systems, or other associated infrastructure do not occupy more than approximately 25% of a cell.

**Performance Objectives Required:**

Yes  No

PR\_1  
Residential Receptor

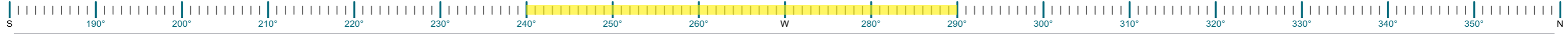

Dwelling/Public Viewpoint ID:

**PR\_2**

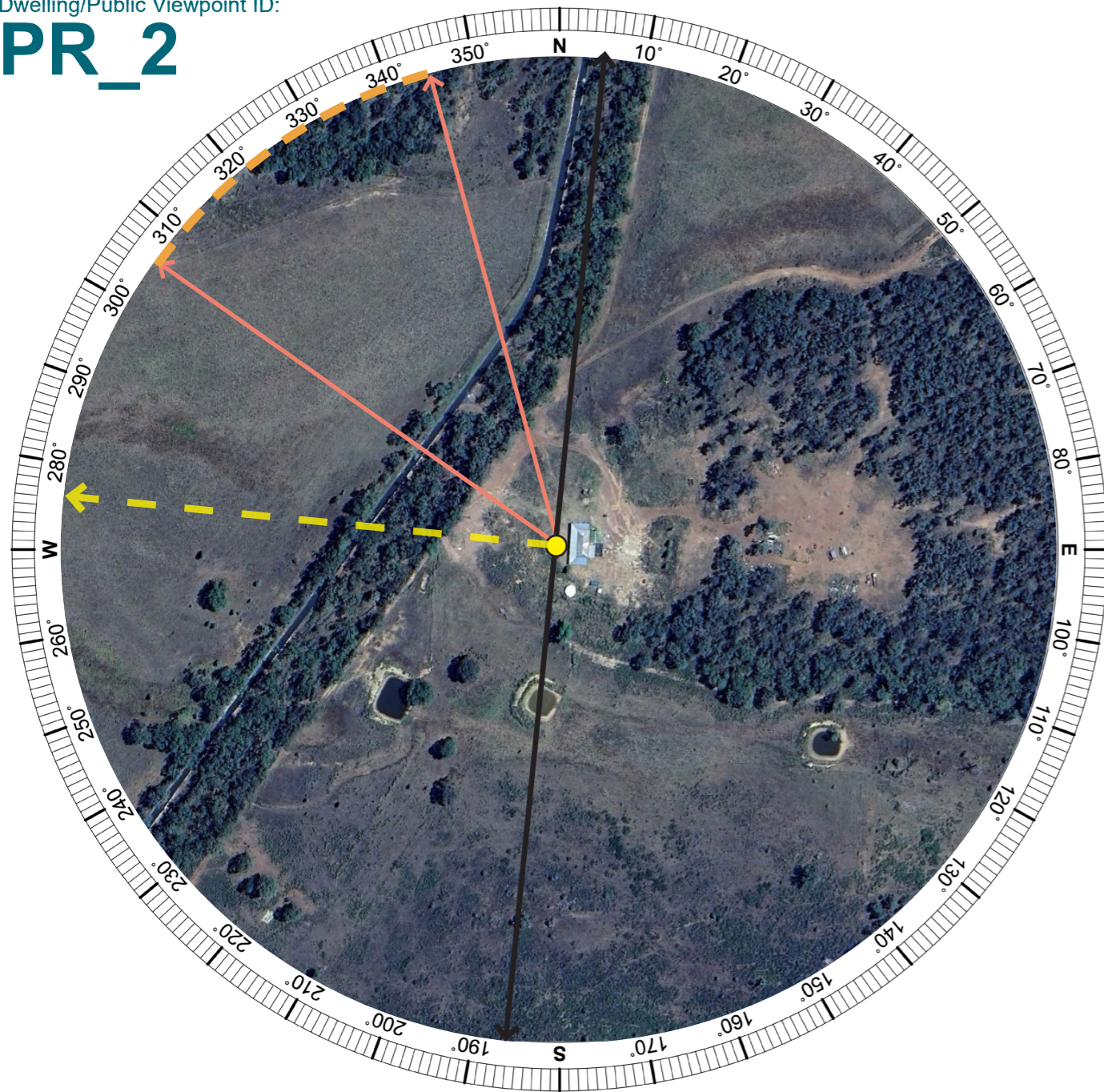

**LEGEND**

- Direction of potential visible Development Footprint
- Extent of potential visible Development Footprint
- Direction of the Wireframe
- Extent of Panorama
- Location of the viewpoint

Aerial Image - Wireframe Location (Aerial Image Source: Google Earth 2023)

**Residential Receptor PR\_2**

Receptor Assessment:								
Coordinates	Distance to development:	Viewpoint Type:	Receptor Sensitivity:	Scenic Quality:	Overall Sensitivity:	Occupied Cells:	Magnitude Rating:	Preliminary Visual Impact Rating:
32° 7'37.18"S 149° 13'48.08"E	0.19 km	Residential Receptor	Moderate	Low	Moderate	2	Very Low	Low

**OCCUPIED CELL COUNT**

Occupied Cell (greater than 25%)

A cell is unoccupied if elements of the project, including solar panels, battery energy systems, or other associated infrastructure do not occupy more than approximately 25% of a cell.

**Performance Objectives Required:**

Yes  No

PR\_2  
Residential Receptor



Dwelling/Public Viewpoint ID:

**PR\_5**

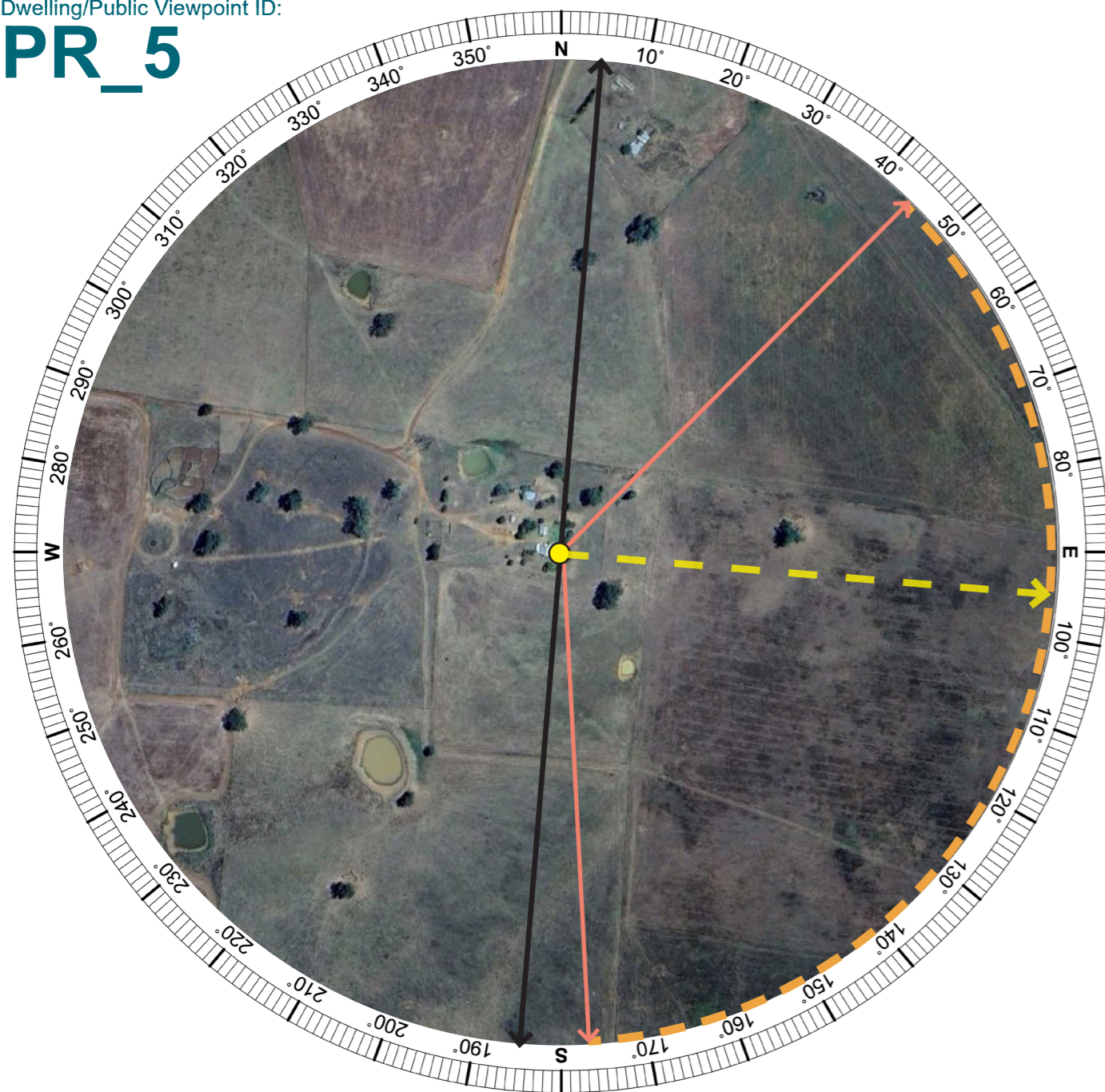

**NOTE:**  
The yellow box is a massing model of the secondary substations proposed with the Project. It is a worst-case visualisation of the potential visual extents of the infrastructure, modelled to the infrastructure boundary and maximum height of 25 m.

**LEGEND**

- Direction of potential visible Development Footprint
- Extent of potential visible Development Footprint
- Direction of the Wireframe
- Extent of Panorama
- Location of the viewpoint

Aerial Image - Wireframe Location (Aerial Image Source: Google Earth 2023)

**Residential Receptor PR\_5**

Receptor Assessment:								
Coordinates	Distance to development:	Viewpoint Type:	Receptor Sensitivity:	Scenic Quality:	Overall Sensitivity:	Occupied Cells:	Magnitude Rating:	Preliminary Visual Impact Rating:
32° 7'52.52"S 149° 11'33.84"E	0.75 km	Residential Receptor	Moderate	Low	Moderate	8	Low	Low

**OCCUPIED CELL COUNT**  
 Occupied Cell (greater than 25%)  
A cell is unoccupied if elements of the project, including solar panels, battery energy systems, or other associated infrastructure do not occupy more than approximately 25% of a cell.

**Performance Objectives Required:**  
 Yes  No

PR\_5  
Residential Receptor

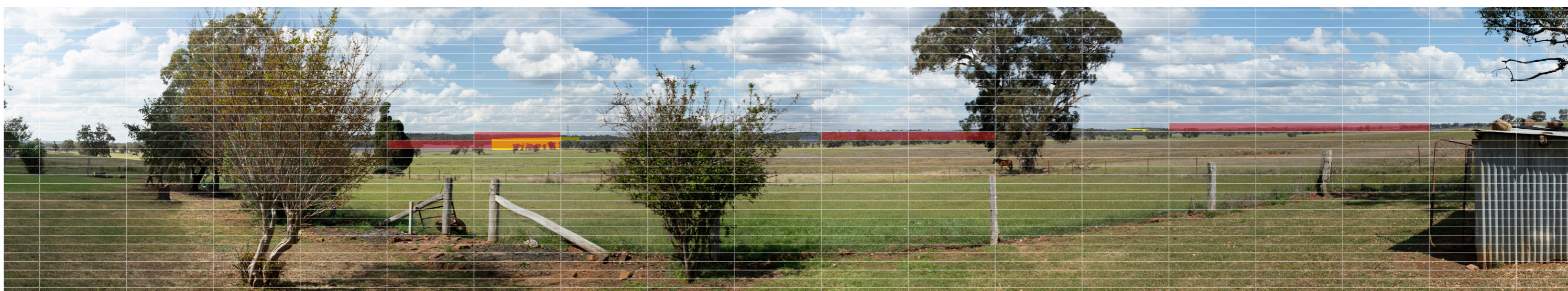

Dwelling/Public Viewpoint ID:

**PR\_6a**



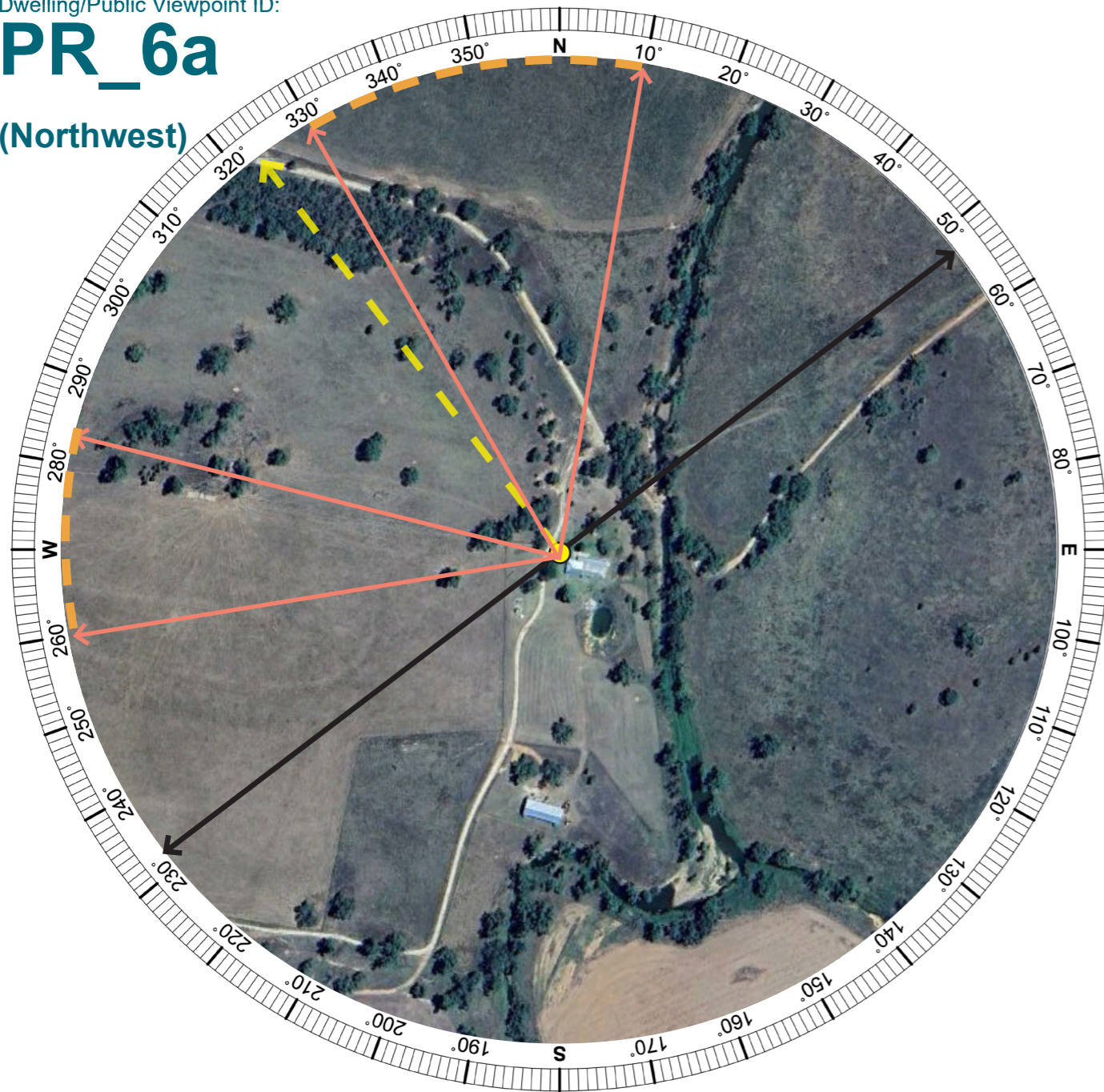

**(Northwest)**



Aerial Image - Wireframe Location (Aerial Image Source: Google Earth 2023)

**NOTE:**  
The yellow box is a massing model of the secondary substations proposed with the Project. It is a worst-case visualisation of the potential visual extents of the infrastructure, modelled to the infrastructure boundary and maximum height of 25 m.

**LEGEND**

-  Direction of potential visible Development Footprint
-  Extent of potential visible Development Footprint
-  Direction of the Wireframe
-  Extent of Panorama
-  Location of the viewpoint

**OCCUPIED CELL COUNT**  
 **Occupied Cell** (greater than 25%)  
*A cell is unoccupied if elements of the project, including solar panels, battery energy systems, or other associated infrastructure do not occupy more than approximately 25% of a cell.*

PR\_6a (North West)  
Residential Receptor



Dwelling/Public Viewpoint ID:

**PR\_6b**

(Southeast)

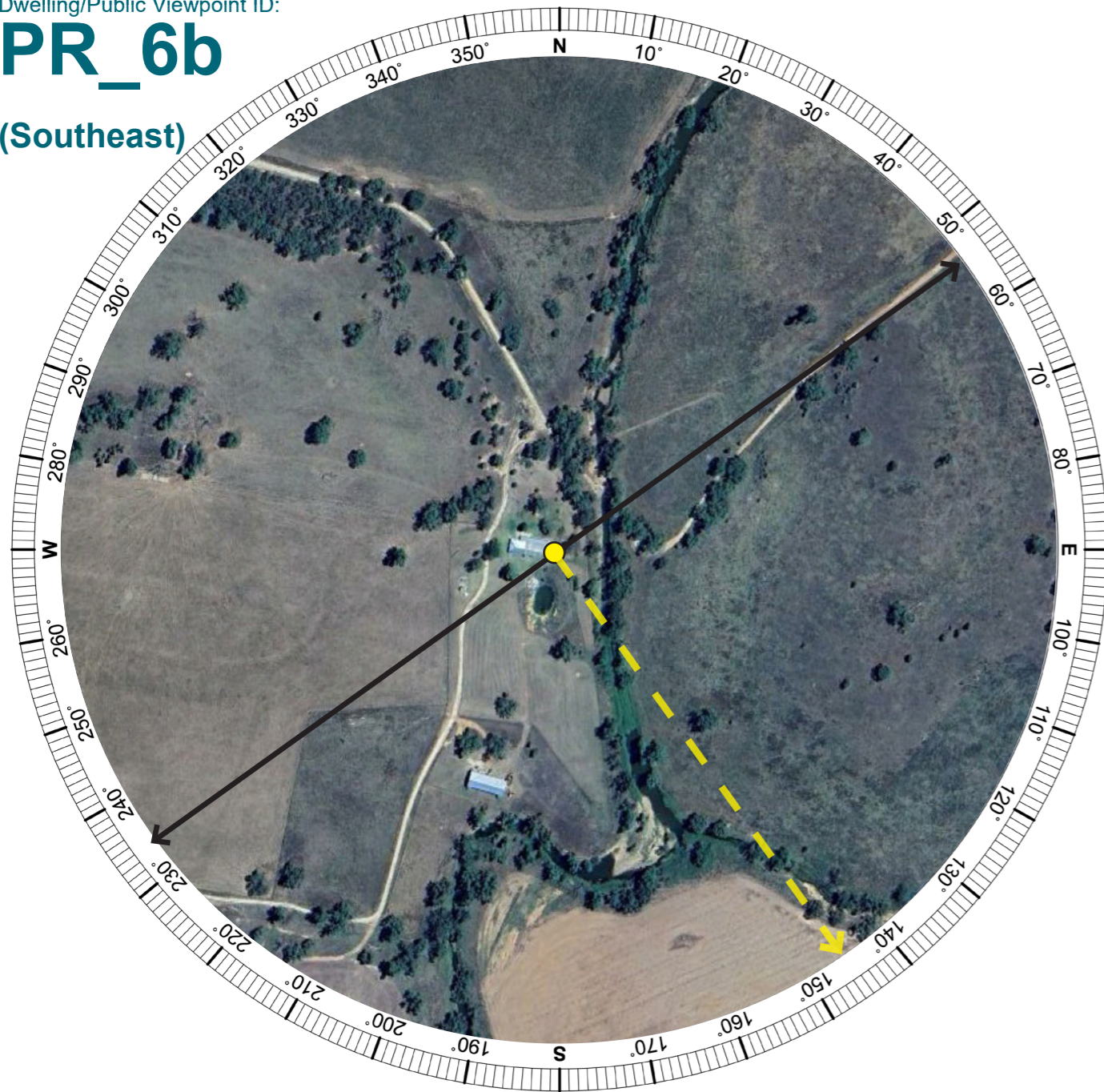

**LEGEND**

- Direction of potential visible Development Footprint
- Extent of potential visible Development Footprint
- Direction of the Wireframe
- Extent of Panorama
- Location of the viewpoint

Aerial Image - Wireframe Location (Aerial Image Source: Google Earth 2023)

**Residential Receptor PR\_6 (North West & South East)**

Receptor Assessment:								
Coordinates	Distance to development:	Viewpoint Type:	Receptor Sensitivity:	Scenic Quality:	Overall Sensitivity:	Occupied Cells:	Magnitude Rating:	Preliminary Visual Impact Rating:
32° 9'32.77"S 149°12'38.82"E	0.27 km	Residential Receptor	Moderate	Low	Moderate	3	Very Low	Low

**OCCUPIED CELL COUNT**

Occupied Cell (greater than 25%)

A cell is unoccupied if elements of the project, including solar panels, battery energy systems, or other associated infrastructure do not occupy more than approximately 25% of a cell.

**Performance Objectives Required:**

Yes  No

PR\_6b (South East)  
Residential Receptor



Dwelling/Public Viewpoint ID:

**X05**

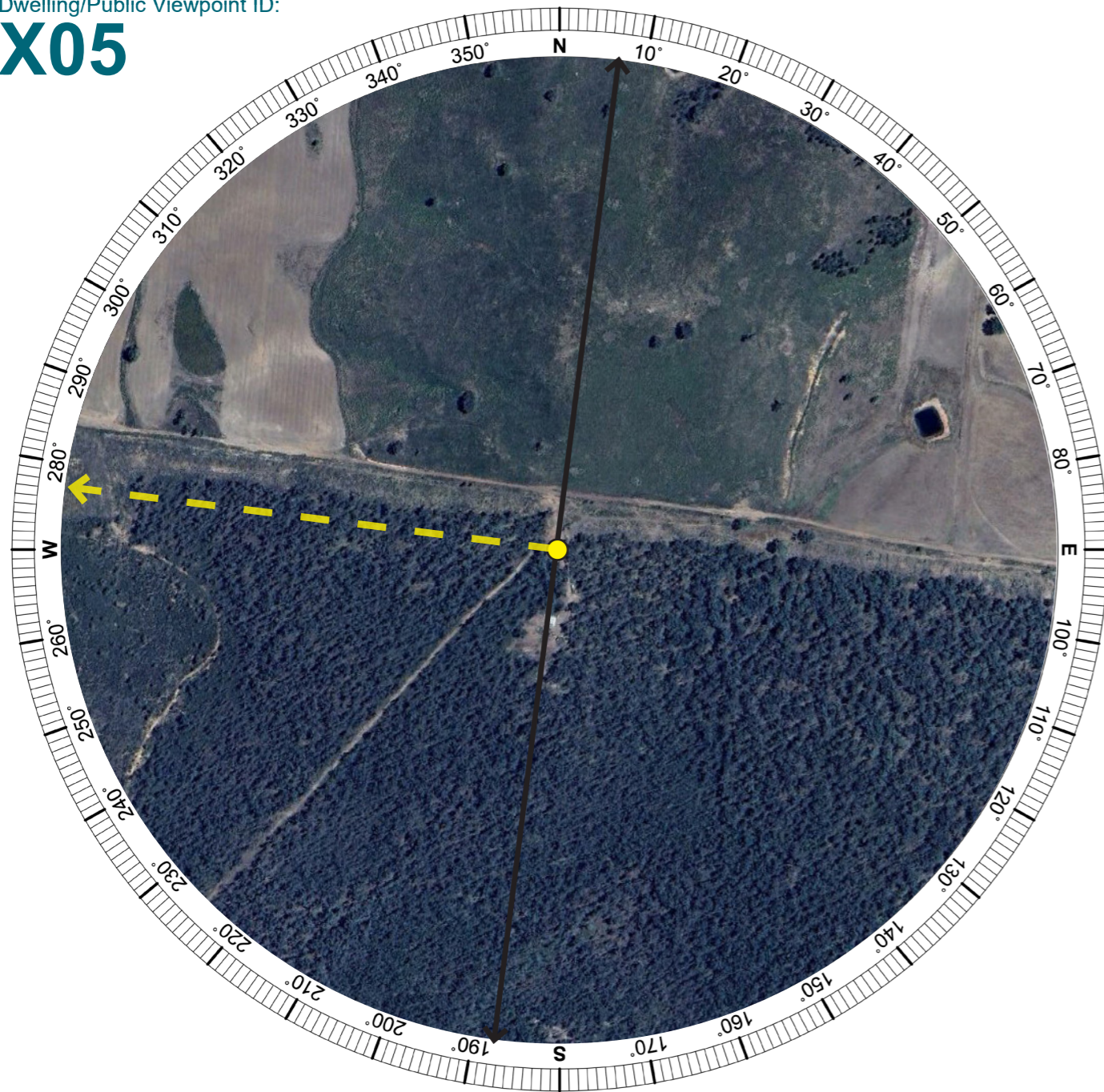

**LEGEND**

- Direction of potential visible Development Footprint
- Extent of potential visible Development Footprint
- Direction of the Wireframe
- Extent of Panorama
- Location of the viewpoint

Aerial Image - Wireframe Location (Aerial Image Source: Google Earth 2023)

**Residential Receptor X05**

Receptor Assessment:								
Coordinates	Distance to development:	Viewpoint Type:	Receptor Sensitivity:	Scenic Quality:	Overall Sensitivity:	Occupied Cells:	Magnitude Rating:	Preliminary Visual Impact Rating:
32° 6'51.14"S 149°14'18.88"E	0.71 km	Residential Receptor	Moderate	Low	Moderate	0	Very Low	Low

**OCCUPIED CELL COUNT**  
 Occupied Cell (greater than 25%)  
A cell is unoccupied if elements of the project, including solar panels, battery energy systems, or other associated infrastructure do not occupy more than approximately 25% of a cell.

**Performance Objectives Required:**  
 Yes  No

X05  
Residential Receptor



Dwelling/Public Viewpoint ID:

# VP03

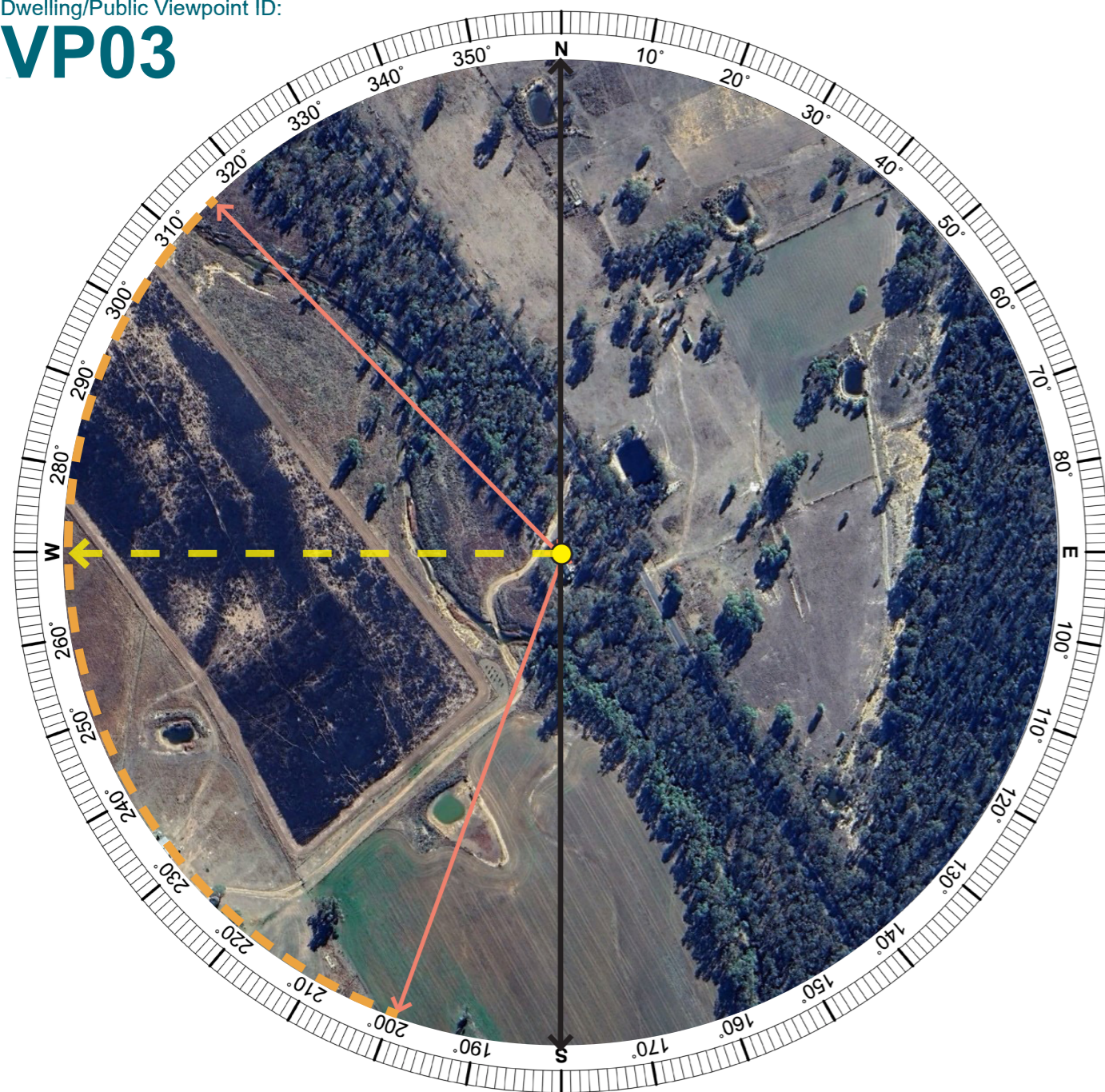

**NOTE:**  
The blue box is a massing model of the Main Substation and BESS proposed with the Project. It is a worst-case visualisation of the potential visual extents of the infrastructure, modelled to the infrastructure boundary and maximum height of 25 m (substation) and 4m (BESS).

**LEGEND**

- Direction of potential visible Development Footprint
- Extent of potential visible Development Footprint
- Direction of the Wireframe
- Extent of Panorama
- Location of the viewpoint

Aerial Image - Wireframe Location (Aerial Image Source: Google Earth 2023)

**Public Receptor: VP03 (Rural Fire Station)**

Receptor Assessment:								
Coordinates	Distance to development:	Viewpoint Type:	Receptor Sensitivity:	Scenic Quality:	Overall Sensitivity:	Occupied Cells:	Magnitude Rating:	Preliminary Visual Impact Rating:
32°10'47.33"S 149°15'38.68"E	0.13 km	Public Receptor	Low	Low	Low	28	High	Moderate

**OCCUPIED CELL COUNT**  
 Occupied Cell (greater than 25%)  
A cell is unoccupied if elements of the project, including solar panels, battery energy systems, or other associated infrastructure do not occupy more than approximately 25% of a cell.

**Performance Objectives Required:**  
 Yes  No

VP03 (Rural Fire Station)  
Public Receptor

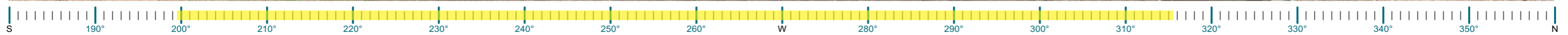
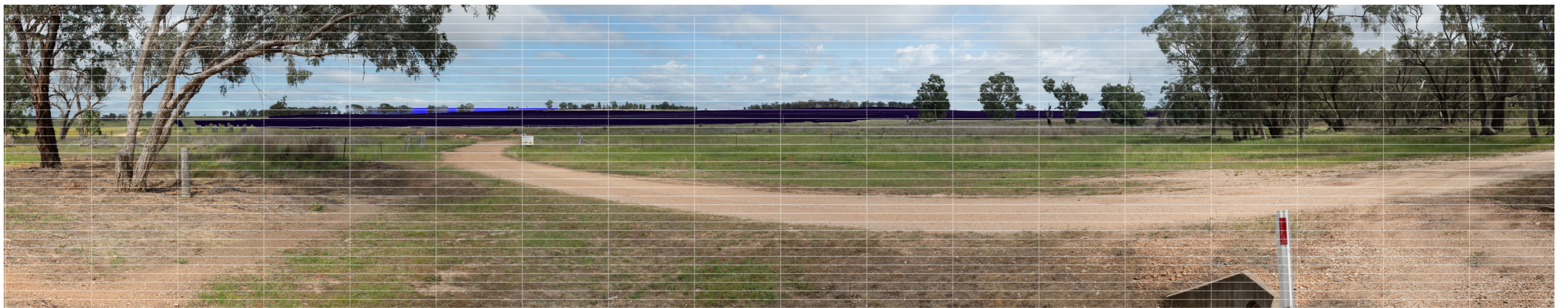
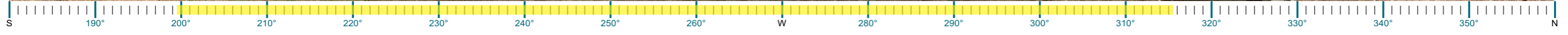

Dwelling/Public Viewpoint ID:

# VP04

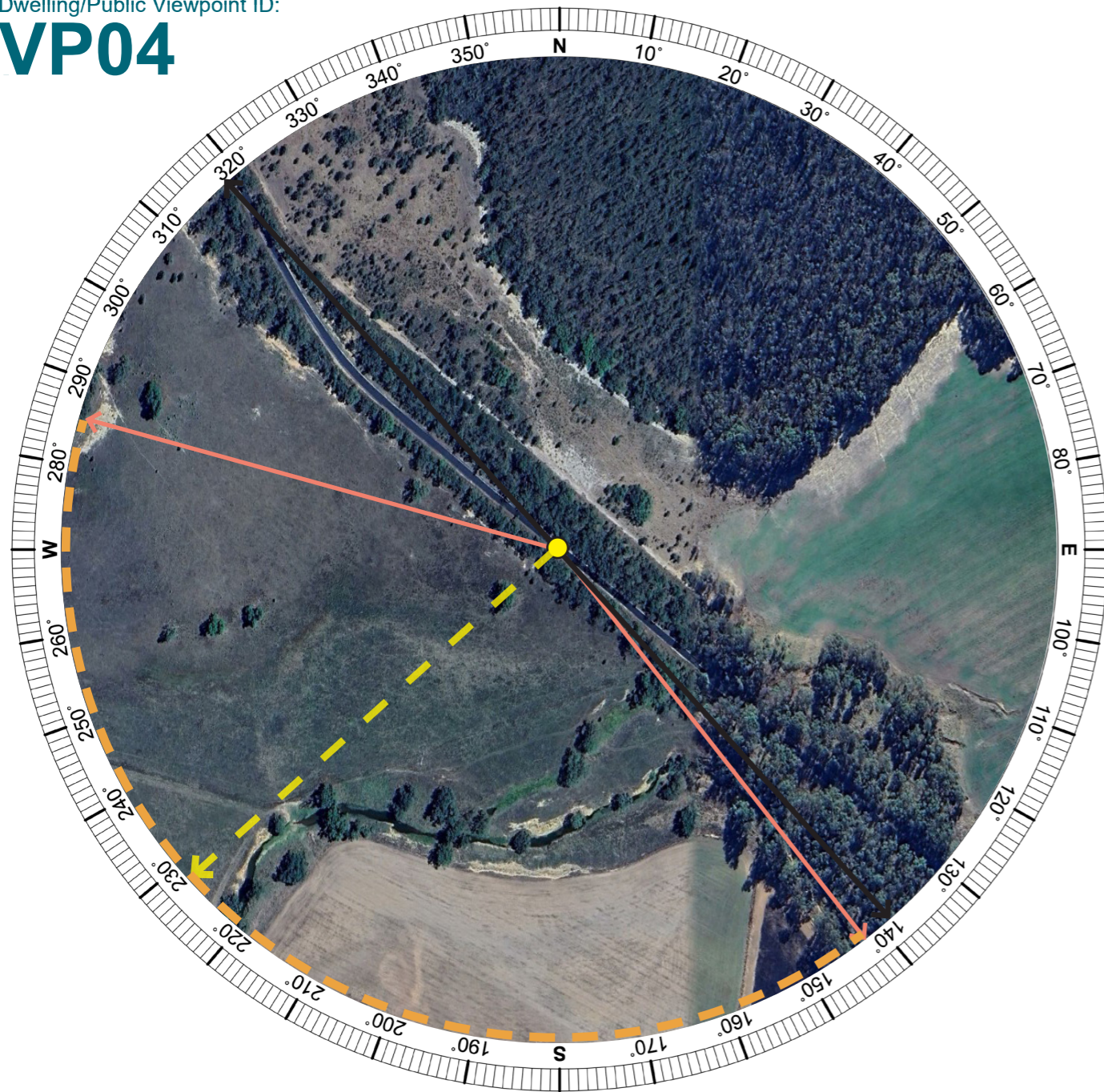

### LEGEND

- Direction of potential visible Development Footprint
- Extent of potential visible Development Footprint
- Direction of the Wireframe
- Extent of Panorama
- Location of the viewpoint

Aerial Image - Wireframe Location (Aerial Image Source: Google Earth 2023)

### Public Receptor VP04

**Receptor Assessment:**

Coordinates	Distance to development:	Viewpoint Type:	Receptor Sensitivity:	Scenic Quality:	Overall Sensitivity:	Occupied Cells:	Magnitude Rating:	Preliminary Visual Impact Rating:
32°09'55.25"S 149°14'42.09"E	0.29 km	Public Receptor	Low	Low	Low	2	Very Low	Very Low

**OCCUPIED CELL COUNT**

Occupied Cell (greater than 25%)

A cell is unoccupied if elements of the project, including solar panels, battery energy systems, or other associated infrastructure do not occupy more than approximately 25% of a cell.

**Performance Objectives Required:**

Yes



No

VP04  
Public Receptor

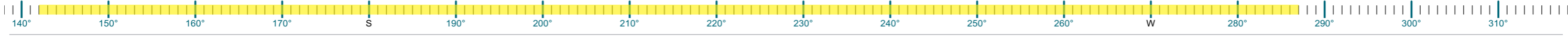
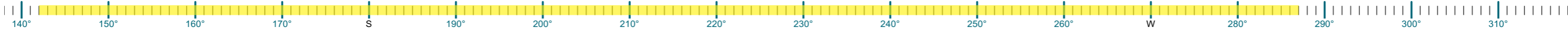

Dwelling/Public Viewpoint ID:

# VP06

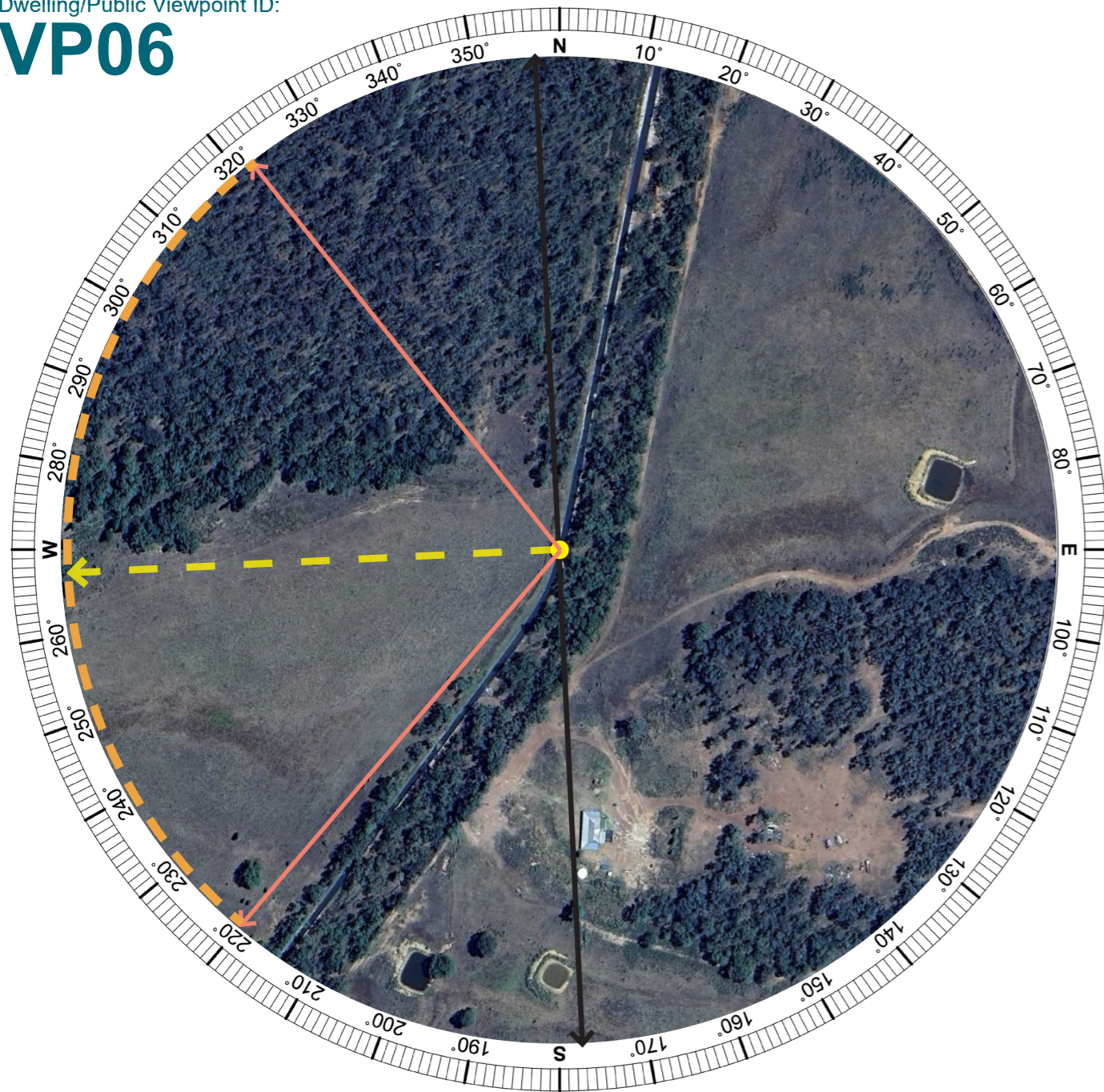

### LEGEND

- Direction of potential visible Development Footprint
- Extent of potential visible Development Footprint
- Direction of the Wireframe
- Extent of Panorama
- Location of the viewpoint

Aerial Image - Wireframe Location (Aerial Image Source: Google Earth 2023)

### Public Receptor VP06

**Receptor Assessment:**

Coordinates	Distance to development:	Viewpoint Type:	Receptor Sensitivity:	Scenic Quality:	Overall Sensitivity:	Occupied Cells:	Magnitude Rating:	Preliminary Visual Impact Rating:
32°07'28.96"S 149°13'47.12"E	0.02 km	Public Receptor	Low	Low	Low	44	Very High	Moderate

**OCCUPIED CELL COUNT**

Occupied Cell (greater than 25%)

A cell is unoccupied if elements of the project, including solar panels, battery energy systems, or other associated infrastructure do not occupy more than approximately 25% of a cell.

**Performance Objectives Required:**



Yes

No

VP06  
Public Receptor

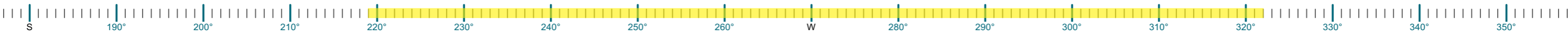

Dwelling/Public Viewpoint ID:  
**VP08**

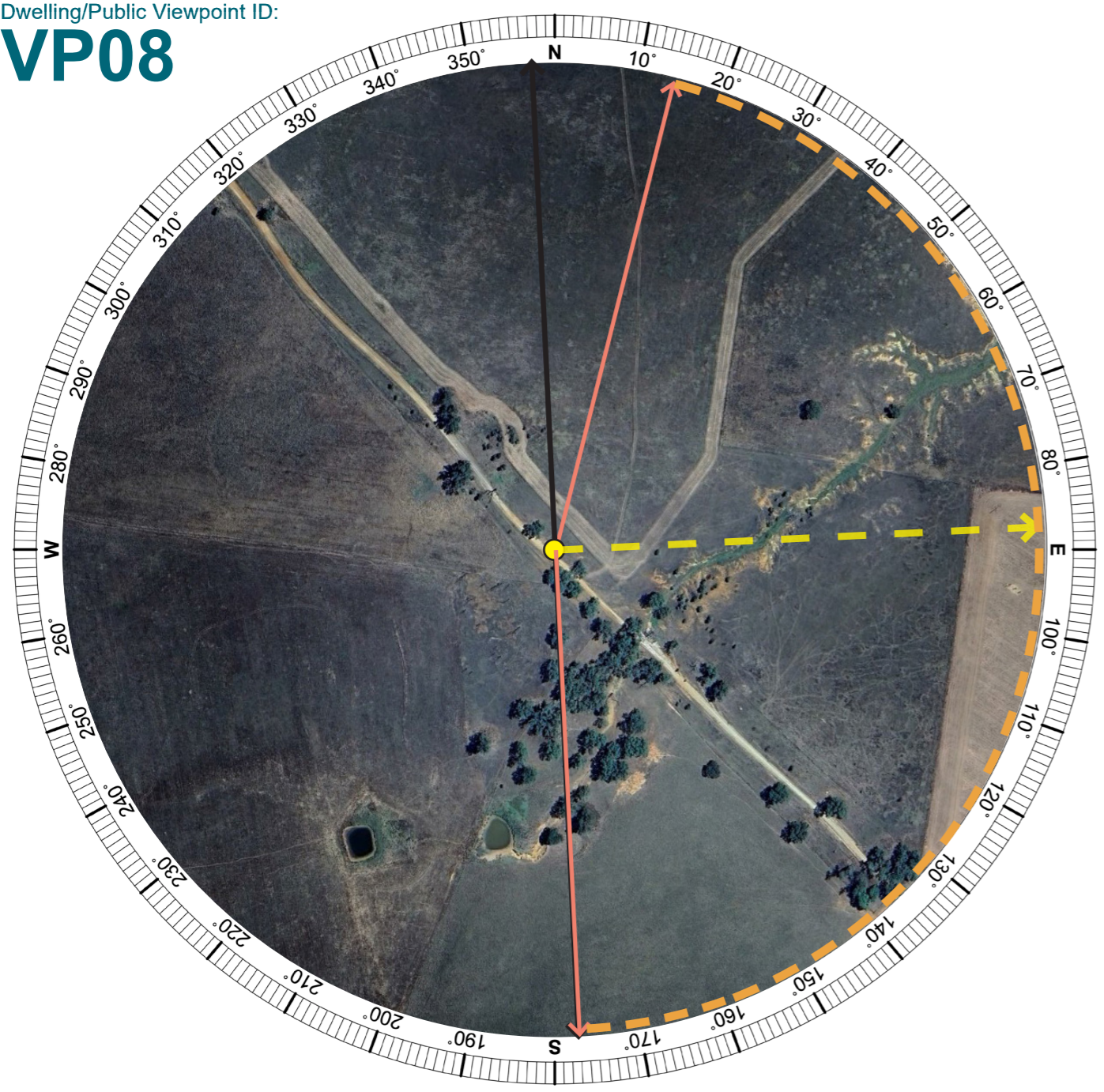

**NOTE:**  
The yellow box is a massing model of the secondary substations proposed with the Project. It is a worst-case visualisation of the potential visual extents of the infrastructure, modelled to the infrastructure boundary and maximum height of 25 m.

**LEGEND**

- Direction of potential visible Development Footprint
- Extent of potential visible Development Footprint
- Direction of the Wireframe
- Extent of Panorama
- Location of the viewpoint

Aerial Image - Wireframe Location (Aerial Image Source: Google Earth 2023)

Public Receptor VP08								
Receptor Assessment:								
Coordinates	Distance to development:	Viewpoint Type:	Receptor Sensitivity:	Scenic Quality:	Overall Sensitivity:	Occupied Cells:	Magnitude Rating:	Preliminary Visual Impact Rating:
32°08'51.84"S 149°11'36.20"E	0.16 km	Public Receptor	Low	Low	Low	18	Moderate	Moderate
<p><b>OCCUPIED CELL COUNT</b></p> <p> Occupied Cell (greater than 25%)</p> <p><small>A cell is unoccupied if elements of the project, including solar panels, battery energy systems, or other associated infrastructure do not occupy more than approximately 25% of a cell.</small></p>							<p><b>Performance Objectives Required:</b></p> <p>Yes <input checked="" type="checkbox"/> No <input type="checkbox"/></p>	

VP08  
Public Receptor

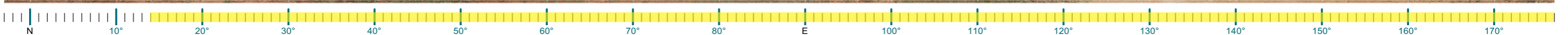
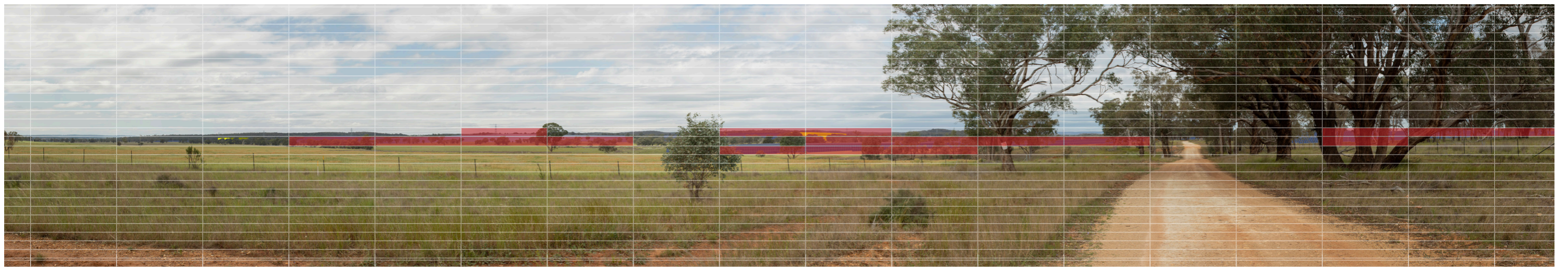

Dwelling/Public Viewpoint ID:

# VP13

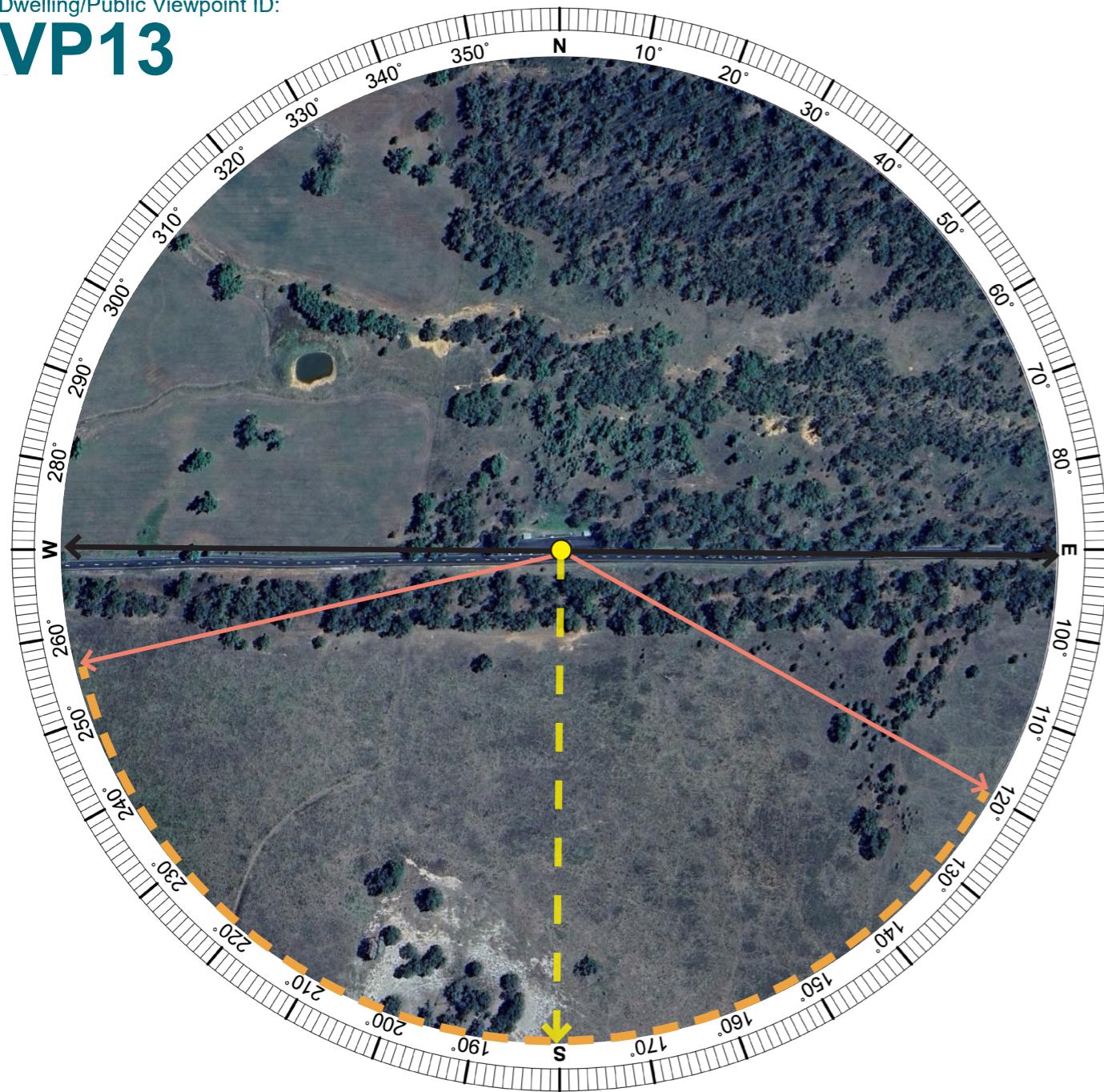

### LEGEND

- Direction of potential visible Development Footprint
- Extent of potential visible Development Footprint
- Direction of the Wireframe
- Extent of Panorama
- Location of the viewpoint

Aerial Image - Wireframe Location (Aerial Image Source: Google Earth 2023)

## Public Receptor: VP14 (Golden Highway Rest Stop)

Receptor Assessment:								
Coordinates	Distance to development:	Viewpoint Type:	Receptor Sensitivity:	Scenic Quality:	Overall Sensitivity:	Occupied Cells:	Magnitude Rating:	Preliminary Visual Impact Rating:
32°06'21.24"S 149°12'37.50"E	0.06 km	Public Receptor	Low	Low	Low	25	Moderate	Low

**OCCUPIED CELL COUNT**

Occupied Cell (greater than 25%)

A cell is unoccupied if elements of the project, including solar panels, battery energy systems, or other associated infrastructure do not occupy more than approximately 25% of a cell.

**Performance Objectives Required:**

Yes  No

VP13 (Golden Highway Rest Stop)

Public Receptor



C

# Glint and Glare Assessment



# 1.0 Introduction

## 1.1 The purpose of this report

Moir Studio have been engaged by Pacific Partnerships Pty Ltd to prepare a glint and glare assessment for the Project. The report will accompany the EIS prepared for the Project.

The Glint and Glare Assessment has been prepared in accordance with the New South Wales (NSW) Department of Housing, Planning and Infrastructure (DPHI) Large-Scale Solar Energy Guideline, referred to hereafter as 'the Guideline' (DPHI, 2024).

Glint is generally defined as a momentary flash of bright light while glare can be defined as continuous source of excessive brightness proportionate to ambient lighting (FAA, 2021).

While glint and glare impacts can be relatively uncommon, it is important to model and assess these impacts to ensure any potential significant impact is avoided or mitigated appropriately (DPHI, 2024).

Assessment needs to be undertaken to ensure that sensitive visual receptors such as road users, surrounding rail network, nearby buildings, air traffic controllers and pilots are not impacted by the proposed development (ForgeSolar, 2022).

## 1.2 Overview of Glint and Glare

The Guideline defines glint as a momentary flash of bright light and glare as a continuous source of continuous, excessive brightness (DPHI, 2024). While it is acknowledged that '*significant glint and glare impacts are uncommon with large-scale solar energy developments*' (DPHI, 2024), the purpose of this report is '*to model and assess these impacts to ensure any potential significant impact is avoided or mitigated appropriately*' (DPHI 2024).

The Guideline provides Performance Objectives for the impacts of glare only, therefore this report has focused on the impact of glare on surrounding receptors. The Performance Objectives of the Guideline for residential receptors, road and rail receptors and aviation receptors are outlined in **Section 4.1**, **Section 5.1** and **Section 6.1** respectively.

A Glint and Glare Assessment needs be undertaken to ensure that sensitive visual receptors such as road users, surrounding rail network, air traffic controllers and pilots are not significantly impacted by the potential glare from the Project, and that nearby residential locations have a reduced level of 'nuisance' from potential glare (DPHI 2024).

### 1.3 Likelihood of Glint & Glare Impacts

The Guidelines note that *'significant glint and glare impacts are uncommon with large-scale solar energy developments because:*

- *Solar panels are designed to absorb light and typically reflect less than 2% of incoming sunlight*
- *Glint and glare typically occur for short periods of time and require very specific geometric and atmospheric conditions*
- *Many solar energy projects are now fitted with tracking panels that can be adjusted to avoid or minimise the geometric conditions needed to cause glint and glare (DPHI 2024).*

The purposes of this report is to identify any potential large scale glare impacts and take appropriate measures to mitigate these potential impacts.

### 1.4 Glint and glare key principles

The key principles for ensuring the Project can be undertaken whilst maintaining an acceptable level of amenity are outlined in the Guideline as follows:

**1. Solar panels should be sited to reduce the likely impacts of glint and glare.**

**2. Solar panels and other infrastructure should be constructed of materials and / or treated to minimise glint and glare.**

**3. If large scale solar energy development is likely to exceed the relevant criteria for glare and standards for glint, mitigation strategies should be adopted.**

## 1.5 Assessment requirements

**Table 1** provides an outline of the assessment requirements for the glint and glare report (in accordance with the Guidelines, DPPI, 2024 and the SEARs) and where these have been addressed in the report. The objective of the assessment as stated in the Guideline is to “*demonstrate that glint and glare would not pose a significant risk to motorists or pilots and that nuisance from glare is minimised for residential locations in accordance with the objectives outlines in [the Guideline]*”.

Report Structure	
Requirements for Glint and Glare Assessment:	Addressed in report:
<p>A description of the proposed PV panels indicating:</p> <ul style="list-style-type: none"> <li>- the axis of rotation and maximum tilt angle</li> <li>- the light absorption efficiency and / or refractive index values at different angles.</li> <li>- whether any backtracking is proposed and the time and duration of these operations.</li> </ul>	<p><b>Refer to:</b></p> <p><b>Section 3.0: Project Overview</b></p>
<p>A justification for excluding any modeled glare results because they would be insignificant due to the size, position and luminance of the glare source or high ambient luminance.</p>	<p><b>Refer to:</b></p> <p><b>Section 2.0: Study Method</b></p>
<p>Results of the glint and glare analysis for each assessable receiver</p>	<p><b>Refer to:</b></p> <p><b>Section 4.0: Residential Receptors</b> (Assess all residential dwellings within 3 km of the proposed solar array that have a line of sight.)</p> <p><b>Section 5.0: Road and Rail Receptors</b> (Assess all roads and rail lines within 5 km of the proposed solar array.)</p> <p><b>Section 6.0: Aviation Receptors</b> (Assess all air traffic control towers and take off / landing approaches to any runway or landing strip within 5 km of the proposed solar array.)</p>
<p>Identification of existing vegetation or built structures and a quantitative assessment of whether these features would eliminate or reduce the modeled impacts.</p>	<p><b>Refer to Summary Tables</b></p>
<p>Details of strategies to either avoid or mitigate impacts including re-siting or sizing the Project, altering the tracking patterns, implementing vegetation screening, or entering neighbor agreements with landowners if all other measures have been exhausted.</p>	<p><b>Refer to:</b></p> <p><b>Section 8.0: Mitigation Recommendations</b></p>

**Table 01 – Overview of Assessment Requirements**

## 2.0 Study Method

### 2.1 Assessment Methodology

Moir Studio have undertaken this glint and glare assessment utilising Solar Glare Hazard Analysis Tool (SGHAT) developed by Sandia National Laboratories. The SGHAT is used to evaluate glare resulting from solar farms at different receptors, based on proximity, orientation and specifications of the PV modules. This tool is recognised by the Australian Government Civil Aviation Safety Authority (CASA).

SGHAT is used to indicate the nature of glare that can be expected at each potential receptor. Glare can be broadly classified into three categories and presented by the following three colours:

- **Green Glare:** Low potential for temporary after-image
- **Yellow Glare:** Potential for temporary after-image
- **Red Glare:** Retinal burn, not expected for PV.

**Note: The main focus of this assessment is the yellow glare. Red glare is not expected for PV and green glare has low potential to cause after image and deemed negligible (HO,2011).**

The glare analysis tool used to assess the glint and glare hazard was run at a simulation interval of one minute, based on the reflectivity of solar rays off PV modules which typically lasts for at least one minute.

Modelling for the solar farms in the SGHAT tool is based on the following factors:

- Position of the sun over time with respect to the location of the proposed solar farm.
- Assessment is based on a worst case scenario assuming clear weather all year round, (ie. no consideration of cloud coverage).
- Tracking axis tilt, tracking axis orientation and properties of the PV modules.
- Potential to screen the impact by surrounding topography (does not take into account intervening elements such as vegetation and built structures).

### 2.2 Modelling Limitations

It should be emphasized that the results of the SGHAT represent a worst-case scenario model. Any results of potential for glare and corresponding proposed mitigation measures are based off this conservative estimate. The analysis gives an indication of potential glint and glare effects and does not consider:

- Intervening elements such as existing vegetation, built structures or topography.
- Varying weather conditions that reduce glare such as cloud cover. The analysis is only based on worst-case scenario weather conditions for glare (i.e. Clear weather conditions).
- Technical improvements to Solar Panel materials to reduce glare reflectivity in the last 10 years (the modelling is based off 2015 Solar Panel materials and glare effects) (Reference Forge Solar and 2015 study).

## 2.2 Modelling Assumptions

The glare and glint impact is calculated utilising the geographic location, elevation, position of the sun and other vector calculations including module orientation, reflective environment and visual factors. Sun position is determined at every one (1) minute interval through out the year.

Although the SGHAT is an instructive tool to understand the impacts of potential glare, it does not consider weather conditions, separation between PV modules and existing surrounding vegetation (if present) between the Project and a sensitive receiver.

Single axis tracking PV panels capable of rotating to a maximum of 60° have been considered to indicate a full rotational range of 120° for this analysis. The trackers are oriented north-south with a maximum pitch distance of 10 m. Glare modelling has been conducted to correspond to maximum tracker height to provide a wider range of observed solar glare based on the extremities.

The glint and glare effects of PV panels depends on the scale and type of infrastructure, the prominence and topography of the site relative to the surrounding environment, and any proposed screening measures to reduce visibility of the site.

Glare modelling has been conducted using the Shade-slope backtracking function within the SGHAT tool. Ground Coverage Ratio (GCR) calculations are used within the SGHAT tool for 'Shade-Slope' backtracking analysis. GCR is defined as the ratio of the array length (L) to proposed pitch distance (R) (Doubleday et al. 2016).

$$\text{GCR} = \frac{L}{R} .$$

For this assessment GCR is calculated considering L = 2.384 m and R = 6 m.  
The resulting GCR = 0.397.

**Section 3.0** provides an overview of the PV panel parameters used for the assessment.

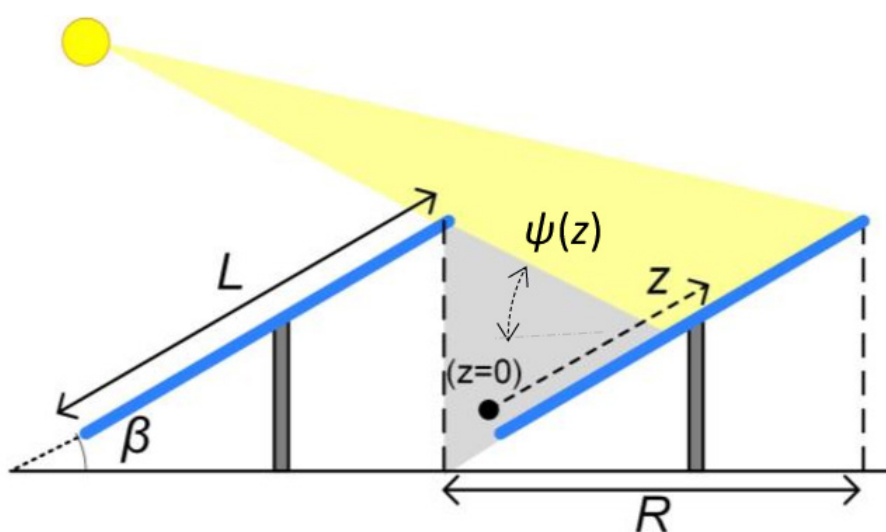

**Figure 01 – GCR Calculation**

Imagery Source: Doubleday et al. 2016

## 2.3 Backtracking Operations

A single axis horizontal tracking system can be configured to do a 'backtracking' technique, which implies that when the sun is low in the sky in the morning or evening, the tracking system can adjust the panels to maximise solar capture while minimising overshadowing.

ForgeSolar uses a simplified model of backtracking. Single-axis trackers follow the movement of the sun as it moves east to west throughout the day. Yields are maximised, and light reflection is minimised when panels are directly facing the sun. In times when the sun is not in the tracking range, we assume that the panels instantaneously revert to their resting angle of 0°. Due to this, glare from the backtracking mechanism will be more conservatively simulated and at times of sunset and sunrise, when the sun is at a lower angle relative to the array, glare impacts will be more noticeable.

Variable angles of incidence of the sun relative to the panels may occur when the tracking system is performing a backtracking operation, and this variation is somewhat represented by SGHAT software.

Shade-slope backtracking function within the SGHAT tool considers the lowest possible panel rotation angle during backtracking. Therefore, backtracking operations are determined using the 0° resting angle option. This function simulates the impression of the panels returning to a pre-defined angle after the maximum tilt angle has been attained.

It is important to note that this backtracking modelling is not a realistic representation of how a backtracking technique would work in actuality, but gives some idea of the potential glare consequences of shifting the PV panels away from the sun after the maximum tilt is reached.

The following parameters have been considered in Scenario 1 to simulate a typical backtracking process for the proposed development:

- A maximum tracking angle of 60° is considered to indicate a full rotational range of 120°.
- As no 'backtracking' is expected to occur during daylight hours, the 'resting angle' is determined as 60°, assuming that the PV modules will be following the sun during all daylight hours where the maximum tilt of 60° will be reached for sunrise and sunset.
- The movement of the PV modules backtracking to 0° is only expected to occur during the night, and therefore has not been considered in this assessment.

## 2.4 Operational Management Strategy

Utilising operational management techniques is an alternative mitigation measure to alter the functioning of the PV array during the backtracking mode. This method serves to mitigate glare effectively. To address this strategy and reduce the potential glare impacts linked to the Project, it has been rigorously assessed and modelled adjustments to the tracking patterns using ForgeSolar.

The following aspects of each scenario have been undertaken to ascertain an appropriate mitigation strategy:

- **Scenario 1** (worst case): Normal tracking during daylight hours, assuming that the PV modules will be following the sun during all daylight hours where the maximum tilt of 60° will be reached for sunrise and sunset. The movement of the PV modules backtracking to 0° is only expected to occur during the night, and therefore has not been considered in this assessment. Scenario was modelled as a worst-case scenario for the Project. In this case, the panels move between the operational range (maximum tilt) discussed in Section 2.4. (Refer to Figure 02).

SGHAT - Normal Tracking Mode with Backtracking only occurring at nighttime with a resting angle of 0°  
Maximum Tracking Angle +/- 60°

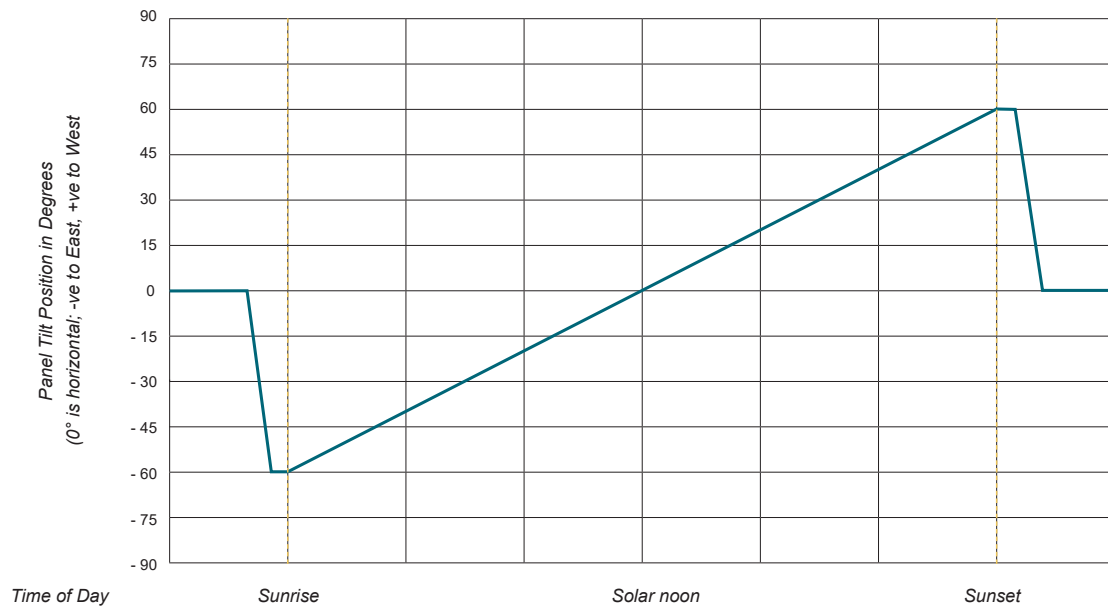

**LEGEND**

— 0° Resting Angle

**Figure 02** – Normal Tracking with Backtracking and Resting Angle of 0° (2025)

## 3.0 Project Overview

### 3.1 Solar Panel Specifications

To attain optimum solar energy collection, the Project modelling has utilised a maximum rotational range of  $120^\circ$ . The panels are fixed on a tubular frame with a single axis tracking procedure. For accuracy, glare analysis has been performed using maximum tracker height not exceeding 2.234 m when facing at the highest angle.

Refer to **Figure 03** for typical panel dimensions utilised for this assessment.

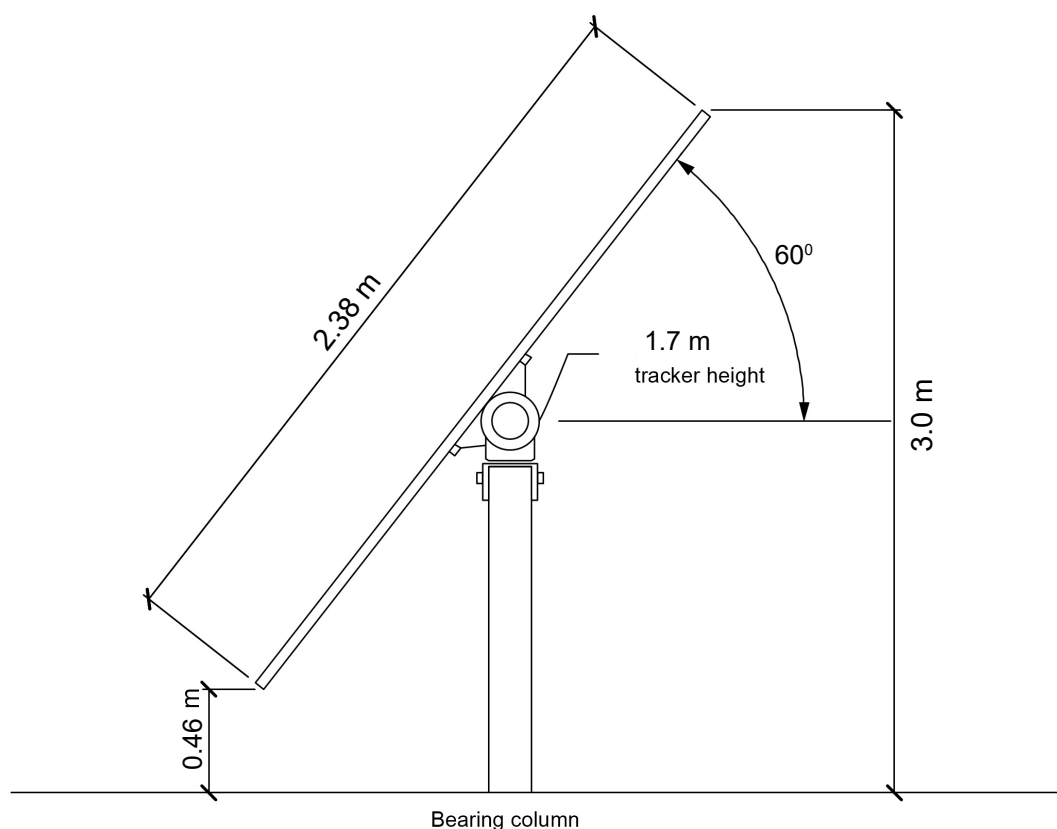

**Figure 03** – PV Parameters utilised for this assessment

Imagery Source: Provided by the Client

General Solar PV system inputs:			
Input Data	Units	Value	Comments
Time Zone	UTC	+10	NSW time Zone
Orientation of Array	Degrees	0	Rows aligned in north-south directions
PV Surface materials	-	Smooth Glass with Anti-Reflective Coating	Provided by Pacific Partnership
Mounting Type	-	Single Axis Tracking	Provided by Pacific Partnership
Panel Maximum Height	Metres	3.0 m	Provided by Pacific Partnership
Panel Dimensions	Metres	2.38 (L) x 1.30 (W)	Provided by Pacific Partnership
Pitch Distance	Metres	6 m	Provided by Pacific Partnership
Single Axis Tracking Parameters			
Axis Orientation	Degrees	0	Panels orientated north south
Module Offset angle	Degrees	0	Facing upwards Panels rotate during operation
Max tracking angle	Degrees	±60° (Range of 120°)	Panels following the Sun
Resting angle	Degrees	0	Panels following the sun, to represent backtracking and after dark stowing angles
Maximum Tracker Height	Metres	1.7 m	Provided by Pacific Partnership
Backtracking	-	Shade-Slope	Provided by Pacific Partnership
Ground Coverage Ratio	-	39.7% or 0.397	Provided by Pacific Partnership

**Table 02** – Summary of modelling parameters (Scenario 1)

## 3.2 Array layout

A single axis tracking system follows the sun's trajectory and rotates the panels across east to west. There will be an estimated 1.2 - 1.4 million modules mounted on a north/south axis to slowly track the movement of the sun. The rows of modules will be spaced approximately 6 m apart to ensure no shading occurs and allow for ease of access for maintenance purposes (Refer to **Table 02**).

Refer **Figure 04** for PV array areas and sections.

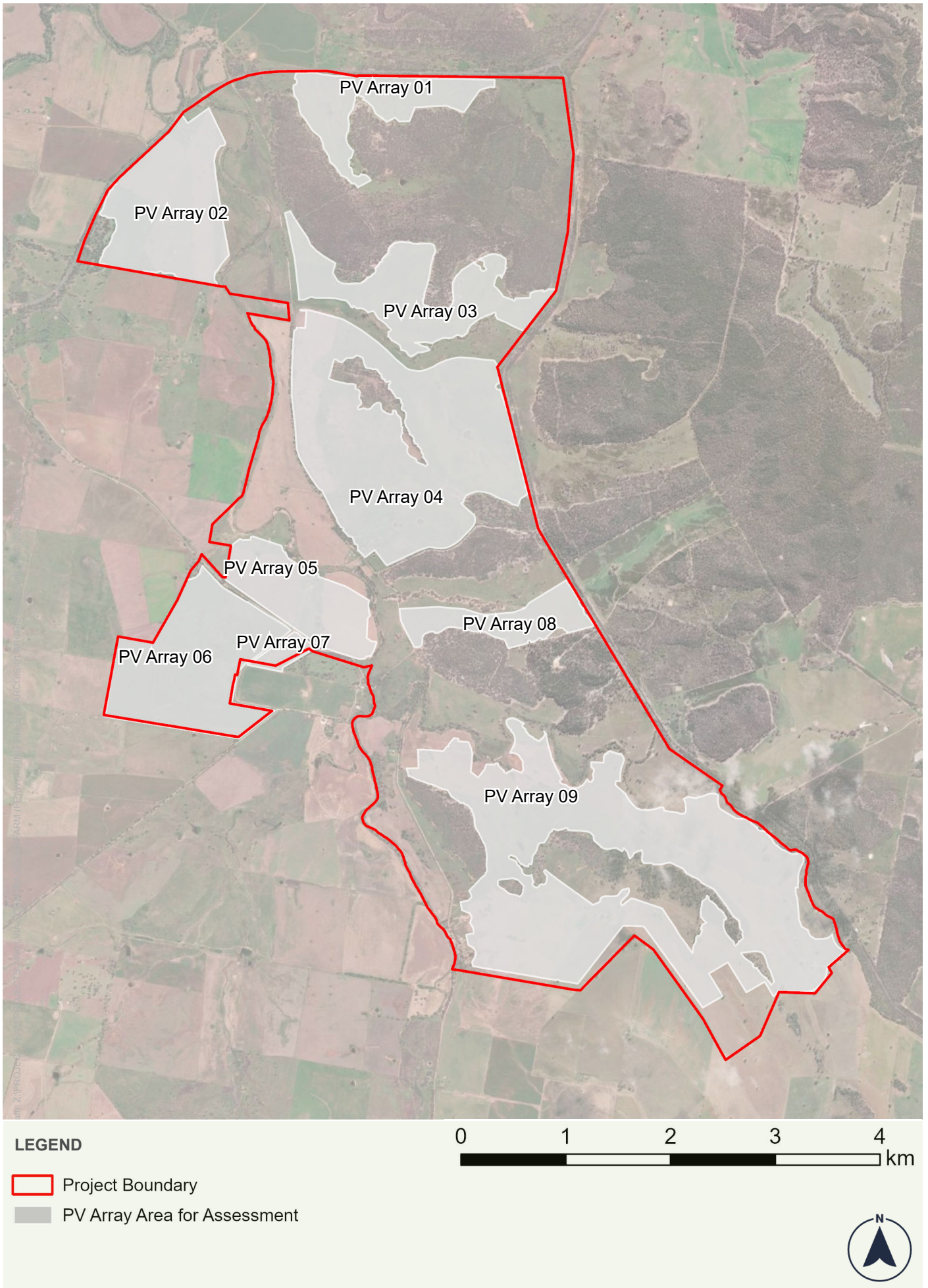

**Figure 04 – PV Areas**

Imagery Source: ESRI Aerial Imagery 2024

## 4.0 Residential Receptors

### 4.1 Overview of methodology

**Table 03** provides an overview of the scope, methodology and performance objectives for assessment of glint and glare on residential receptors

Glint and Glare Requirements - Residential Receptors		
Scope	Methodology	Performance Objective
All residential viewpoints within 3 km of the proposed solar array that have a line of sight.	<b>Analysis of the daily and yearly glare impacts in minutes.</b>	<b>Refer to Table 04.</b>
Representative viewpoints may be used for residential receptors that are clustered together.	<b>All residential receivers must be assessed at a height of 1.5 m above ground level.</b>	

**Note: Modeling for residential receptors is calculated on a receptor height of 1.5 m AGL.**

**Table 03** – Residential Receptors Assessment Requirements (Source: DPFI, 2024)

Impact rating and performance objectives for glare impacts on residential receptors		
High Glare Impact	Moderate Glare Impact	Low Glare Impact
<b>&gt; 30 minutes per day</b>	<b>&lt; 30 minutes per day</b>	<b>&lt; 10 minutes per day</b>
<b>&gt; 30 hours per year</b>	<b>&lt; 30 hours per year</b>	<b>&lt; 10 hours per year</b>
<i>Significant amount of glare that should be avoided</i>	<i>Implement mitigation measures to reduce impacts as far as practicable</i>	<i>No mitigation required</i>

**Table 04** – Residential receptor impact rating and performance objectives (Source: DPFI, 2024)

### 4.2 Residential Receptors

A desktop assessment identified 19 non-associated Residential Receptors with a line of sight to the project within 3 km of the Project (refer **Table 05**). These have been labelled as free standing Observation Point (OP) receptors within the detailed findings (Refer to **Appendix A - Glint and Glare Results**).

**Table 075** provides an overview of the annual glare experienced by the 19 residential receptors based on Scenario 1 (Refer to **Section 2.3**).

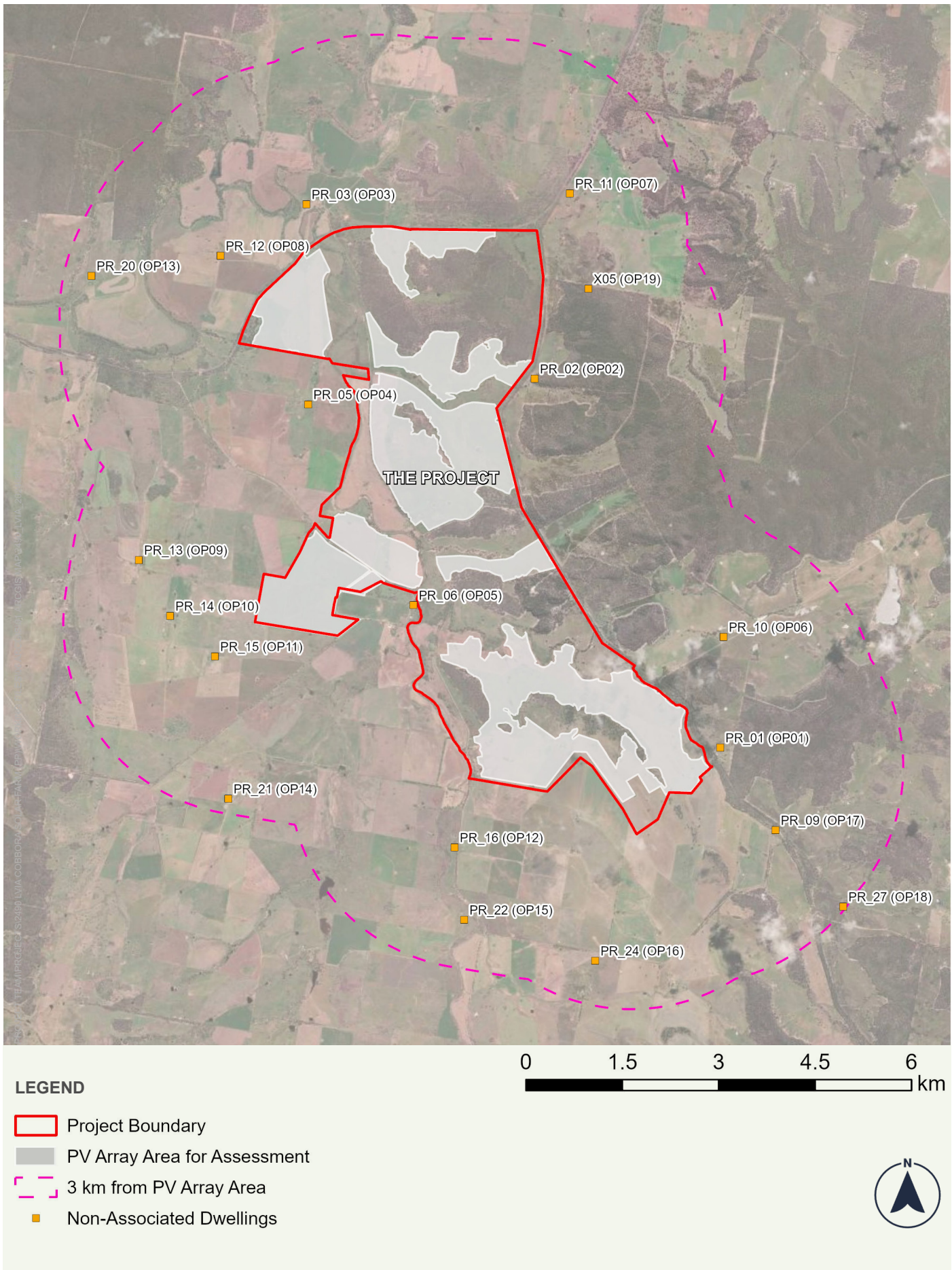

**Figure 05 – Residential Receptors**  
 Imagery Source: ESRI Aerial Imagery 2023

Dwelling	Location	Elevation	Distance to the PV Array Area	Green Glare (Hours Per Year):	Yellow Glare (Hours Per Year):	Recommended Mitigation Measures
OP01 (PR_01)	1613 SPRING RIDGE ROAD, COBBORA, NSW	397.8 m	259 m	0	0	Nil, no glare impacts
OP02 (PR_02)	249 SPRING RIDGE ROAD, COBBORA, NSW	397.5 m	189 m	0	0	Nil, no glare impacts
OP03 (PR_03)	?? SANDY CREEK ROAD, COBBORA, NSW	348.9 m	797 m	0	0	Nil, no glare impacts
OP04 (PR_05)	223 SWEENEYS LANE, ELONG ELONG, NSW	365.9 m	750 m	0	0	Nil, no glare impacts
OP05 (PR_06)	530 SWEENEYS LANE, GOOLMA, NSW	367.7 m	272 m	0	0	Nil, no glare impacts
OP06 (PR_10)	901 SPRING RIDGE ROAD, COBBORA, NSW	394.7 m	1284 m	0	0	Nil, no glare impacts
OP07 (PR_11)	2005 GOLDEN HIGHWAY, COBBORA, NSW	403.3 m	2551 m	0	0	Nil, no glare impacts
OP08 (PR_12)	GOLDEN HIGHWAY, ELONG ELONG, NSW	362.7 m	921 m	0	0	Nil, no glare impacts
OP09 (PR_13)	2807 GOLDEN HIGHWAY, ELONG ELONG, NSW	394.7 m	1953 m	0	0	Nil, no glare impacts
OP10 (PR_14)	224 SWEENEYS LANE, ELONG ELONG, NSW	392 m	1325 m	0	0	Nil, no glare impacts
OP11 (PR_15)	1311 TALLAWONGA ROAD, ELONG ELONG, NSW	410.6 m	821 m	0	0	Nil, no glare impacts
OP12 (PR_16)	1069 SANDY CREEK ROAD, COBBORA, NSW	384.4 m	1156 m	0	0	Nil, no glare impacts
OP13 (PR_20)	2950 GOLDEN HIGHWAY, ELONG ELONG, NSW	348.8 m	2609 m	0	0	Nil, no glare impacts
OP14 (PR_21)	1002 TALLAWONGA ROAD, ELONG ELONG, NSW	408.4 m	2780 m	0	0	Nil, no glare impacts
OP15 (PR_22)	1198 SANDY CREEK ROAD, COBBORA, NSW	388.2 m	2185 m	0	0	Nil, no glare impacts

Dwelling	Location	Elevation	Distance to the PV Array Area	Green Glare (Hours Per Year):	Yellow Glare (Hours Per Year):	Recommended Mitigation Measures
OP16 (PR_24)	403 DAPPER ROAD, DUNEDOO, NSW	445.5 m	2127 m	0	0	Nil, no glare impacts
OP17 (PR_09)	1168 SPRING RIDGE ROAD, COBBORA, NSW	396.9 m	1383 m	0	0	Nil, no glare impacts
OP18 (PR_27)	1350 SPRING RIDGE ROAD, DUNEDOO, NSW	408.9 m	2946 m	0	0	Nil, no glare impacts
OP19 (X05)	133 SPRING RIDGE ROAD, COBBORA, NSW	432.2 m	713 m	0	0	Nil, no glare impacts

**Table 05 – Residential receptor assessment results**

Based on the Scenario 1 glare assessment, no potential “Yellow” or “Green” glare has been identified for any non-associated dwellings within the Study Area.

Therefore, no mitigation measures are required for non-associated dwellings.

The detailed findings for the receptors are included in the **Appendix A - Glint and Glare Results**.

\*It is crucial to emphasise that this assessment is based on a worst-case scenario and does not account for factors such as weather conditions, intervening elements like vegetation, or built structures, which may influence the actual glare experienced.

## 5.0 Road and Rail Receptors

### 5.1 Overview of Methodology

**Table 06** provides an overview of the scope, methodology and performance objectives for assessment of glint and glare on road and railway line receptors.

#### Glint and Glare Requirements - Road & Rail

Scope	Methodology	Performance Objective
All roads and rail lines within 1 km of the proposed solar array.	<b>Solar glare analysis to identify whether glint and glare are geometrically possible within the forward looking eyeline of motorists and rail operators.</b>	<b>If glare is geometrically possible then measures should be taken to eliminate the occurrence of glare. Alternatively, the proponent must demonstrate that glare would not significantly impede the safe operation of vehicles or the interpretation of signals and signage.</b>

**Note: Modeling for road receptors is calculated on a maximum height of 2.4 m AGL - representative of the eye level for truck drivers** (Source: Austroads Ltd. 2021).

**Modeling for rail lines is based a representative eye height of 3 m AGL to represent the eye level of train drivers** (Source: Transport Asset Standards Authority 2020).

**Table 06 – Road and Rail Receptor Assessment Requirements** (Source: DPFI, 2024)

### 5.2 Road and Rail Receptors

A total of six (6) road receptors were identified within 1 km of the development footprint. These have been shown on **Figure 5**.



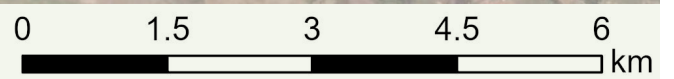
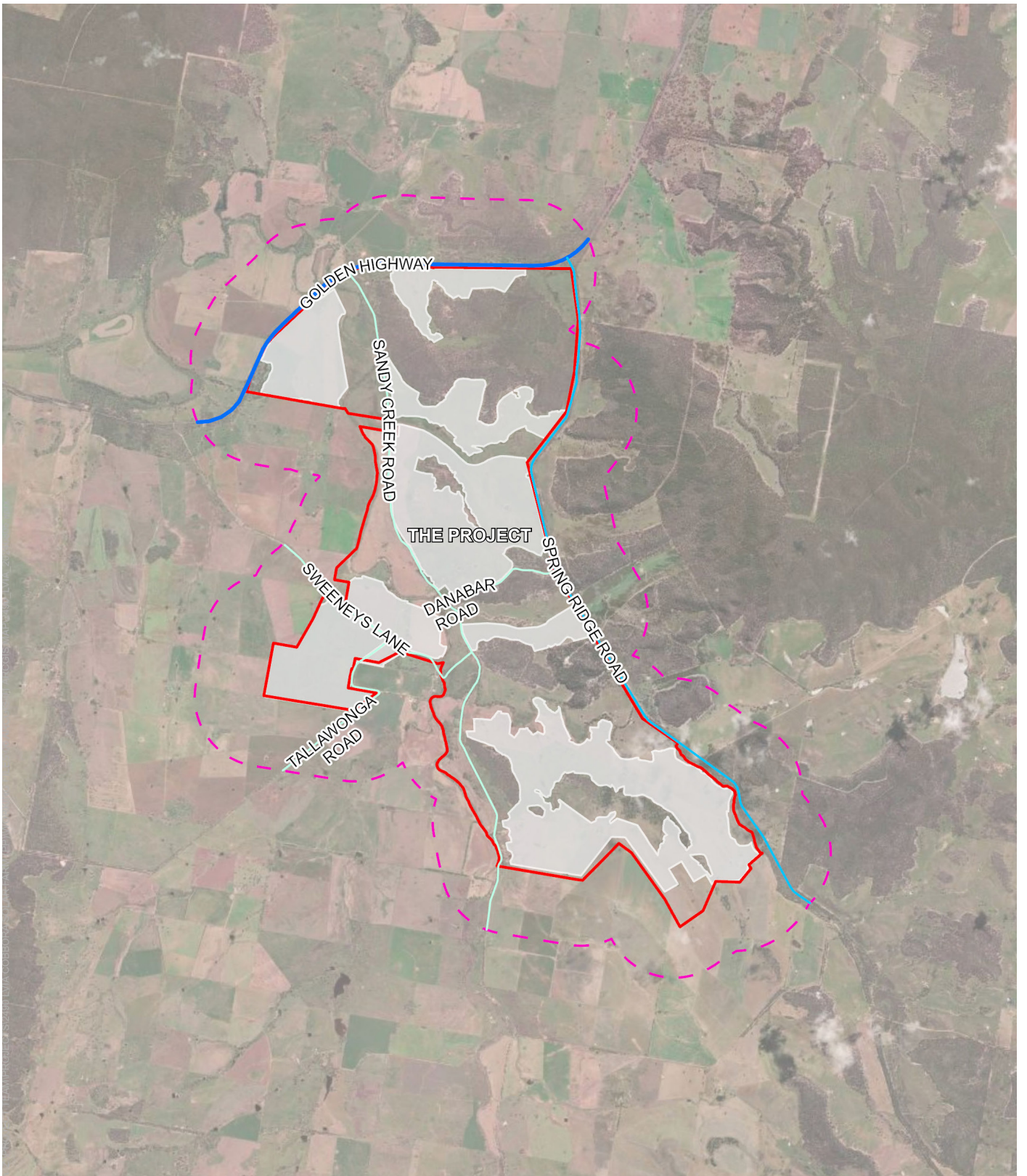

- Golden Highway
- Spring Ridge Road
- Danabar Road (unsealed)
- Sandy Creek Road (unsealed)
- Sweeneys Lane (unsealed)
- Tallawonga Road (unsealed)

No rail receptors were identified within 1 km of the PV Array Area.

**Figure 06** illustrates road receptors identified within 1 km of the PV Array Area.



**LEGEND**

-  Project Boundary
-  PV Array Area for Assessment
-  3 km from PV Array Area
-  Highway
-  Road



**Figure 06 – Rail and Road Receptors**  
Imagery Source: ESRI Aerial Imagery 2023

### 5.3 Results of Glint and Glare Assessment - Road and Rail

Two (2) road receptors (Golden Highway and Spring Ridge Road) were considered as part of the assessment.

**Table 07** provides an overview of the annual glare experienced along the six (6) road receptors based on Scenario 1.

Road / Rail Receptor:	Approximate Distance to PV Array Area:	Green Glare (Hours Per Year):	Yellow Glare (Hours Per Year):	Existing screening factors:	Mitigation Recommendations:
Golden Highway	0.01 km	0	0	Scattered roadside vegetation along the road to the south.	Nil, no glare impacts
Spring Ridge Road	0.02 km	82.8	0	Roadside vegetation along the road to the west	Green glare impacts. No mitigation required. Refer to Section 5.3.1 for details.
Danabar Road - unsealed	0.02 km	0	0	Dense Roadside vegetation present along both sides of road	Nil, no glare impacts
Sandy Creek Road - unsealed	0.01 km	0	0	Scattered roadside vegetation along road, with pockets of cleared area	Nil, no glare impacts
Sweeneys Lane - unsealed	0.01 km	59.9	0	Small areas of roadside vegetation along road to the south	Green glare impacts. No mitigation required. Refer to Section 5.3.1 for details.
Tallawonga Road - unsealed	0.01 km	273.2	0	Scattered roadside vegetation along southern section of road. Limited vegetation adjacent to project.	Green glare impacts. No mitigation required. Refer to Section 5.3.1 for details.

**Table 07 – Road & Rail receptor assessment results**

### 5.3.1 Impacts of Glare on Road and Rail Receptors

Based on Scenario 1, the glare assessment indicates that Spring Ridge Road, Sweeneys Lane and Tallawonga Road experience potential 'green' glare. The potential for after-image from green glare is low; however, it may cause eye strain if observed for long periods. Due to the speed of travel along the road and rail routes, the time frame to experience the impacts of 'green' glare are short, therefore, the impacts of 'green' glare are low and do not require mitigation.

Based on Scenario 1, the glare assessment indicates that zero (0) roads have the potential to experience 'yellow' glare. 'Yellow' glare is expected to cause a temporary after-image, which can impact those operating vehicles on nearby roads and railways. Therefore, any potential for 'yellow' glare requires mitigation for road and rail receptors. However, as no roads have the potential to experience 'Yellow' glare, no mitigation is required.

### 5.3.2 Golden Highway

Based on the Scenario 1 glare assessment, it has been determined that no potential for glare is expected to occur on the Golden Highway. Therefore, no mitigation is required.

### 5.3.3 Spring Ridge Road

Based on the Scenario 1 glare assessment, it has been determined that Spring Ridge Road is projected to experience no 'yellow' glare and approximately 82.8 hours per year of potential 'green' glare. However, as stated in **Section 5.3.1**, the impacts from 'green' glare only occur if observed for long periods. Due to the speed of travel along the road, the time frame to experience the impacts of 'green' glare is short, therefore, the impacts of 'green' glare are low and do not require mitigation.

### 5.3.4 Danabar Road (unsealed)

Based on the Scenario 1 glare assessment, it has been determined that no potential for glare is expected to occur on Danabar Road. Therefore, no mitigation is required.

### 5.3.5 Sandy Creek Road (unsealed)

Based on the Scenario 1 glare assessment, it has been determined that no potential for glare is expected to occur on Sandy Creek Road. Therefore, no mitigation is required.

### 5.3.6 Sweeneys Lane (unsealed)

Based on the Scenario 1 glare assessment, it has been determined that Sweeneys Lane is projected to experience no 'yellow' glare and approximately 59.9 hours per year of potential 'green' glare. However, as stated in **Section 5.3.1**, the impacts from 'green' glare only occur if observed for long periods. Due to the speed of travel along the road, the time frame to experience the impacts of 'green' glare is short, therefore, the impacts of 'green' glare are low and do not require mitigation.

### 5.3.7 Tallawonga Road (unsealed)

Based on the Scenario 1 glare assessment, it has been determined that Tallawonga Road is projected to experience no 'yellow' glare and approximately 273.2 hours per year of potential 'green' glare. However, as stated in **Section 5.3.1**, the impacts from 'green' glare only occur if observed for long periods. Due to the speed of travel along the road, the time frame to experience the impacts of 'green' glare is short, therefore, the impacts of 'green' glare are low and do not require mitigation.

\*It is crucial to emphasise that this assessment is based on a worst-case scenario and does not account for factors such as weather conditions, intervening elements like vegetation, or built structures, which may influence the actual glare experienced.

More detailed findings for the glare impact on the six (6) Road Receptors are included in **Appendix A - Glint and Glare Results**.

## 6.0 Aviation Receptors

### 6.1 Overview of Methodology

**Table 08** provides an overview of the scope, methodology and performance objectives for assessment of glint and glare on aviation receptors.

#### Glint and Glare Requirements - Aviation Receptors

Scope	Methodology	Performance Objective
All air traffic control towers and take off / landing approaches to any runway or landing strip within 5 km of the proposed solar array.	<b>Solar glare analysis that is worst case in all scenarios accounting for all aircraft using the airport (e.g. gliders, helicopters etc).</b>	<b>Any glint and glare should be avoided unless the aerodrome operator agrees that the impact would not be material (e.g. occurs at times when there are no flights or would not pose a safety risk to airport operations).</b>

**Note: Modeling for Flight Path receptors is calculated on a threshold crossing height of 50 ft (15 m) in two mile (3.21 km) point ground elevation and the  $\pm 50$  degree azimuthal and 30 degree vertical viewing angle representative of the pilot field view from cockpit (Source: Rogers, 2015).**

**Table 08** – Aviation Receptor Assessment Requirements (Source: DPHI, 2024)

### 6.2 Aviation Receptors

The desktop assessment did not identify any landing strips within 5 km of the PV Array Area and therefore no further assessment was required.

# 7.0 Performance Objectives

## 7.1 Summary of assessment results

### 7.1.1 Residence Receptors

**Table 04** provides an overview of the scope, methodology and performance objectives for assessment of glint and glare on residence receptors. The assessment undertaken by Moir Studio has been summarised below:

**No potential glare has been identified for any non-associated dwellings within the 3 km Study Area.**

Therefore, no mitigation measures are required for non-associated dwellings.

The detailed glint and glare findings for the receptors are included in the **Appendix A - Glint and Glare Results**.

### 7.1.2 Road and Rail Receptors

**Table 06** provides an overview of the scope, methodology and performance objectives for assessment of glint and glare on Road receptors. The assessment undertaken by Moir Studio has been summarised below:

**No potential “Yellow” glare has been identified for any roads within the 1 km Study Area.**

Spring Ridge Road, Sweeneys Lane and Tallawonga Road have the potential to experience ‘green’ glare.

‘Green’ glare is not expected to cause a temporary after-image, and only causes eye strain after a long period. Due to the speed of travel along the road and rail routes, the time frame to experience the impacts of ‘green’ glare are short, therefore the impacts of ‘green’ glare are negligible and do not require mitigation.



# 8.0 Mitigation Measures

## 8.1 Summary of assessment results

### 8.1 Overview of Impacts

In accordance with the Guideline: *Details of strategies to either avoid or mitigate impacts of the Project must be provided.* The following summarises the key results and proposed mitigation strategies to address the potential impacts.

#### 8.1.1 Residential Receptors

**No potential glare has been identified for any non-associated dwellings within the 3 km Study Area.**

Therefore, no mitigation measures are required for non-associated dwellings.

#### 8.1.2 Road and Rail Receptors

**No potential “Yellow” glare has been identified for any roads within the 1 km Study Area.**

Three (3) roads (Spring Ridge Road, Sweeneys Lane and Tallawonga Road) have the potential to experience ‘green’ glare.

‘Green’ glare is not expected to cause a temporary after-image, and only causes eye strain after a long period. Due to the speed of travel along the road and rail routes, the time frame to experience the impacts of ‘green’ glare are short, therefore the impacts of ‘green’ glare are negligible and do not require mitigation.

#### 8.1.3 Aviation Receptors

No Aviation receptors were identified within 5 km of the Project.

## 9.0 Conclusion

The purpose of this report is to identify the potential glint and glare impacts from Cobbora Solar Farm, on residential receptors (within 3 km of the PV Array Area), road and rail receptors (within 1 km of the PV Array Area) and aviation receptors (within 5 km of the PV Array Area).

Based on the assumptions and aforementioned parameters for Scenario 1 (see **Section 2.4**), the findings of the assessment were:

19 residential receptors were identified within 3 km of the PV Array Area. No potential glare has been identified for any non-associated dwellings within the 3 km Study Area.

Two (2) sealed roads (Golden Highway, Spring Ridge Road) and four (4) unsealed roads (Danabar Road, Sandy Creek Road, Sweeneys Lane and Tallawonga Road) were identified within 1 km of the solar array. No potential "Yellow" glare has been identified for any roads within the 1 km Study Area. Three (3) roads (Spring Ridge Road, Sweeneys Lane and Tallawonga Road) have the potential to experience 'green' glare.

'Green' glare is not expected to cause a temporary after-image, and only causes eye strain after a long period. Due to the speed of travel along the road and rail routes, the time frame to experience the impacts of 'green' glare are short, therefore the impacts of 'green' glare are negligible and do not require mitigation.

No aviation receptors were identified within 5 km of the PV Array Area. Therefore, no further assessment was required.

In conclusion, the Project aligns with the Guideline requirements as no glare impacts were identified for all residential receptors and no 'yellow' glare were identified for all road receivers.

## References

Austrroads Ltd. 2021, Guide to Road Design Part 3: Geometric Design, AGRD03-16, Austrroads Ltd., Sydney, NSW.

Australian Rail Track Corporation Limited 2010, Signal Sighting and Position, ESC-04-01, Australian Rail Track Corporation Limited, Sydney.

ForgeSolar n.d., [www.forgesolar.com](http://www.forgesolar.com), viewed 21 February 2023, <<https://www.forgesolar.com/help/#glare>>.

Federal Aviation Administration (2021). Final Policy, Review of Solar Energy System Projects on Federally Obligated Airports. Document Number 2021-09862.

Google Earth, Imagery date 26 March 2021.

Ho, C. K., Ghanbari, C. M., and Diver, R. B., 2011, "Methodology to Assess Potential Glint and Glare Hazards From Concentrating Solar Power Plants: Analytical Models and Experimental Validation", ASME J. Sol. Energy Eng., 133.

New South Wales Department of Planning, Housing & Infrastructure, Large-Scale Solar Energy Guideline, November 2024

New South Wales Department of Planning, Housing & Infrastructure, Large-Scale Solar Energy Guideline- Technical Supplement - Landscape and Visual Impact Assessment, November 2024

Rogers, J. A., et al. (2015). "Evaluation of Glare as a Hazard for General Aviation Pilots on Final Approach", Federal Aviation Administration (link)

Transport Asset Standards Authority 2020, Minimum Operating Standards for Rolling Stock – General Interface Requirements, T HR RS 00100 ST, Transport NSW, Sydney.

**Glint and Glare Assessment Results  
Attachment A -  
Scenario 1**

# FORGESOLAR GLARE ANALYSIS

Project: 2490 COBBORA SOLAR FARM\_Part A\_North

Site configuration: 2490 COBBORA SOLAR FARM\_Part A\_North\_60d\_v02

Created 14 Mar, 2025

Updated 14 Mar, 2025

Time-step 1 minute

Timezone offset UTC10

Minimum sun altitude 0.0 deg

DNI peaks at 1,000.0 W/m<sup>2</sup>

Category 100 MW to 1 GW

Site ID 144131.21977

Ocular transmission coefficient 0.5

Pupil diameter 0.002 m

Eye focal length 0.017 m

Sun subtended angle 9.3 mrad

PV analysis methodology V2

## Summary of Results Glare with low potential for temporary after-image predicted

PV Array	Tilt °	Orient °	Annual Green Glare		Annual Yellow Glare		Energy kWh
			min	hr	min	hr	
PV1	SA tracking	SA tracking	0	0.0	0	0.0	-
PV2	SA tracking	SA tracking	0	0.0	0	0.0	-
PV3	SA tracking	SA tracking	4,967	82.8	0	0.0	-
PV4	SA tracking	SA tracking	0	0.0	0	0.0	-
PV5	SA tracking	SA tracking	0	0.0	0	0.0	-
PV6	SA tracking	SA tracking	16,390	273.2	0	0.0	-
PV7	SA tracking	SA tracking	3,593	59.9	0	0.0	-
PV8	SA tracking	SA tracking	0	0.0	0	0.0	-

Total glare received by each receptor; may include duplicate times of glare from multiple reflective surfaces.

Receptor	Annual Green Glare		Annual Yellow Glare	
	min	hr	min	hr
Danabar Road - unsealed	0	0.0	0	0.0
Golden Highway	0	0.0	0	0.0

Receptor	Annual Green Glare		Annual Yellow Glare	
	min	hr	min	hr
Sandy Creek Road - unsealed	0	0.0	0	0.0
Spring Ridge Road	4,967	82.8	0	0.0
Sweeneys Lane - unsealed road	3,593	59.9	0	0.0
Tallawonga Road - unsealed	16,390	273.2	0	0.0
OP 1	0	0.0	0	0.0
OP 2	0	0.0	0	0.0
OP 3	0	0.0	0	0.0
OP 4	0	0.0	0	0.0
OP 5	0	0.0	0	0.0
OP 6	0	0.0	0	0.0
OP 7	0	0.0	0	0.0
OP 8	0	0.0	0	0.0
OP 9	0	0.0	0	0.0
OP 10	0	0.0	0	0.0
OP 11	0	0.0	0	0.0
OP 12	0	0.0	0	0.0
OP 13	0	0.0	0	0.0
OP 14	0	0.0	0	0.0
OP 15	0	0.0	0	0.0
OP 16	0	0.0	0	0.0
OP 17	0	0.0	0	0.0
OP 18	0	0.0	0	0.0
OP 19	0	0.0	0	0.0

# Component Data

## PV Arrays

**Name:** PV1  
**Axis tracking:** Single-axis rotation  
**Backtracking:** Shade-slope  
**Tracking axis orientation:** 0.0°  
**Max tracking angle:** 60.0°  
**Resting angle:** 60.0°  
**Ground Coverage Ratio:** 0.397  
**Rated power:** -  
**Panel material:** Smooth glass with AR coating  
**Reflectivity:** Vary with sun  
**Slope error:** correlate with material



Vertex	Latitude (°)	Longitude (°)	Ground elevation (m)	Height above ground (m)	Total elevation (m)
1	-32.109804	149.211297	388.05	1.70	389.75
2	-32.108175	149.209658	377.94	1.70	379.64
3	-32.108130	149.208945	376.09	1.70	377.79
4	-32.109974	149.208179	380.98	1.70	382.68
5	-32.111933	149.208044	383.75	1.70	385.45
6	-32.112910	149.208824	389.18	1.70	390.88
7	-32.114139	149.208395	384.84	1.70	386.54
8	-32.114975	149.208902	387.11	1.70	388.81
9	-32.114901	149.209913	390.24	1.70	391.94
10	-32.115387	149.210633	391.86	1.70	393.56
11	-32.116004	149.209347	392.35	1.70	394.05
12	-32.114995	149.207613	390.34	1.70	392.04
13	-32.113869	149.206478	390.20	1.70	391.90
14	-32.111752	149.205446	385.16	1.70	386.86
15	-32.109760	149.203379	379.40	1.70	381.10
16	-32.107661	149.202600	371.50	1.70	373.20
17	-32.107017	149.202973	370.56	1.70	372.26
18	-32.106249	149.202828	368.86	1.70	370.56
19	-32.106497	149.222961	385.31	1.70	387.01
20	-32.107155	149.222949	386.18	1.70	387.88
21	-32.107401	149.221471	386.02	1.70	387.72
22	-32.109352	149.219925	392.97	1.70	394.67
23	-32.108805	149.218093	389.77	1.70	391.47
24	-32.109019	149.214928	387.17	1.70	388.87
25	-32.110209	149.214428	392.34	1.70	394.04
26	-32.110256	149.213405	386.77	1.70	388.47
27	-32.109947	149.212953	384.08	1.70	385.78
28	-32.110304	149.212144	389.34	1.70	391.04

**Name:** PV2

**Axis tracking:** Single-axis rotation

**Backtracking:** Shade-slope

**Tracking axis orientation:** 0.0°

**Max tracking angle:** 60.0°

**Resting angle:** 60.0°

**Ground Coverage Ratio:** 0.397

**Rated power:** -

**Panel material:** Smooth glass with AR coating

**Reflectivity:** Vary with sun

**Slope error:** correlate with material



Vertex	Latitude (°)	Longitude (°)	Ground elevation (m)	Height above ground (m)	Total elevation (m)
1	-32.123636	149.189631	367.24	1.70	368.94
2	-32.123736	149.187642	369.46	1.70	371.16
3	-32.123070	149.183384	366.63	1.70	368.33
4	-32.119878	149.184978	370.25	1.70	371.95
5	-32.119124	149.184796	370.51	1.70	372.21
6	-32.118760	149.183191	371.38	1.70	373.08
7	-32.117279	149.183940	369.91	1.70	371.61
8	-32.115771	149.184973	366.23	1.70	367.93
9	-32.111505	149.190116	354.17	1.70	355.87
10	-32.110059	149.191352	351.86	1.70	353.56
11	-32.110782	149.191985	353.97	1.70	355.67
12	-32.109449	149.194086	349.00	1.70	350.70
13	-32.112343	149.195808	350.16	1.70	351.86
14	-32.112641	149.195322	351.32	1.70	353.02
15	-32.113192	149.194965	352.18	1.70	353.88
16	-32.114419	149.194766	353.74	1.70	355.44
17	-32.115289	149.194929	353.37	1.70	355.07
18	-32.122170	149.196457	354.91	1.70	356.61
19	-32.123710	149.195027	358.05	1.70	359.75
20	-32.124748	149.195335	356.49	1.70	358.19
21	-32.124250	149.191549	362.29	1.70	363.99
22	-32.123800	149.190922	365.60	1.70	367.30

**Name:** PV3

**Axis tracking:** Single-axis rotation

**Backtracking:** Shade-slope

**Tracking axis orientation:** 0.0°

**Max tracking angle:** 60.0°

**Resting angle:** 60.0°

**Ground Coverage Ratio:** 0.397

**Rated power:** -

**Panel material:** Smooth glass with AR coating

**Reflectivity:** Vary with sun

**Slope error:** correlate with material



Vertex	Latitude (°)	Longitude (°)	Ground elevation (m)	Height above ground (m)	Total elevation (m)
1	-32.120044	149.204006	366.92	1.70	368.62
2	-32.121549	149.205262	368.54	1.70	370.24
3	-32.122589	149.207221	376.82	1.70	378.52
4	-32.123428	149.206961	370.13	1.70	371.83
5	-32.124319	149.207908	369.69	1.70	371.39
6	-32.124309	149.209814	372.62	1.70	374.32
7	-32.123640	149.210864	377.78	1.70	379.48
8	-32.120742	149.213233	394.00	1.70	395.70
9	-32.120864	149.217162	400.93	1.70	402.63
10	-32.121339	149.217313	400.02	1.70	401.72
11	-32.125893	149.216170	380.78	1.70	382.48
12	-32.126554	149.217789	383.51	1.70	385.21
13	-32.126447	149.218559	382.74	1.70	384.44
14	-32.125864	149.219162	386.76	1.70	388.46
15	-32.124074	149.219146	396.02	1.70	397.72
16	-32.123512	149.219447	394.50	1.70	396.20
17	-32.122228	149.221344	390.51	1.70	392.21
18	-32.122983	149.222360	382.23	1.70	383.93
19	-32.122100	149.222201	387.76	1.70	389.46
20	-32.122046	149.221685	390.09	1.70	391.79
21	-32.121602	149.222703	390.54	1.70	392.24
22	-32.121629	149.223882	391.05	1.70	392.75
23	-32.121934	149.224452	393.40	1.70	395.10
24	-32.123100	149.224338	393.59	1.70	395.29
25	-32.123581	149.224078	389.60	1.70	391.30
26	-32.123308	149.223944	388.17	1.70	389.87
27	-32.123424	149.223597	385.35	1.70	387.05
28	-32.124263	149.223313	381.96	1.70	383.66
29	-32.125169	149.224284	381.81	1.70	383.51
30	-32.125520	149.225366	382.14	1.70	383.84
31	-32.125214	149.227032	385.35	1.70	387.05
32	-32.124827	149.227022	388.88	1.70	390.58
33	-32.124693	149.227405	390.12	1.70	391.82
34	-32.124581	149.229620	388.89	1.70	390.59
35	-32.128125	149.226542	381.74	1.70	383.44
36	-32.127097	149.223725	375.82	1.70	377.52
37	-32.126592	149.223252	376.69	1.70	378.39
38	-32.127460	149.221378	375.38	1.70	377.08
39	-32.128680	149.220209	372.22	1.70	373.92
40	-32.128858	149.218215	369.75	1.70	371.45
41	-32.129344	149.217195	368.28	1.70	369.98
42	-32.129304	149.215416	366.19	1.70	367.89
43	-32.129881	149.216967	367.96	1.70	369.66
44	-32.130521	149.215075	367.73	1.70	369.43
45	-32.128847	149.212758	363.00	1.70	364.70
46	-32.128177	149.213000	363.95	1.70	365.65
47	-32.126665	149.211206	363.15	1.70	364.85
48	-32.126790	149.210642	362.28	1.70	363.98
49	-32.126341	149.208907	361.51	1.70	363.21
50	-32.125771	149.208359	361.46	1.70	363.16
51	-32.125615	149.207275	360.79	1.70	362.49
52	-32.125542	149.204790	358.22	1.70	359.92
53	-32.125799	149.203606	356.80	1.70	358.50
54	-32.122261	149.203091	357.25	1.70	358.95
55	-32.118343	149.202017	359.78	1.70	361.48
56	-32.118166	149.202525	364.17	1.70	365.87



**Name:** PV4

**Axis tracking:** Single-axis rotation

**Backtracking:** Shade-slope

**Tracking axis orientation:** 0.0°

**Max tracking angle:** 60.0°

**Resting angle:** 60.0°

**Ground Coverage Ratio:** 0.397

**Rated power:** -

**Panel material:** Smooth glass without AR coating

**Reflectivity:** Vary with sun

**Slope error:** correlate with material



Vertex	Latitude (°)	Longitude (°)	Ground elevation (m)	Height above ground (m)	Total elevation (m)
1	-32.127769	149.208883	363.46	1.70	365.16
2	-32.131485	149.210514	375.87	1.70	377.57
3	-32.131630	149.211512	373.44	1.70	375.14
4	-32.134320	149.214108	386.39	1.70	388.09
5	-32.135546	149.214752	387.08	1.70	388.78
6	-32.136536	149.214677	392.23	1.70	393.93
7	-32.140352	149.217520	388.73	1.70	390.43
8	-32.140652	149.217048	389.74	1.70	391.44
9	-32.138517	149.214720	393.92	1.70	395.62
10	-32.135955	149.214172	392.95	1.70	394.65
11	-32.135119	149.209827	383.54	1.70	385.24
12	-32.133329	149.209656	378.99	1.70	380.69
13	-32.132580	149.206791	368.56	1.70	370.26
14	-32.130840	149.207285	368.51	1.70	370.21
15	-32.130499	149.210069	371.33	1.70	373.03
16	-32.127778	149.208859	363.47	1.70	365.17
17	-32.127149	149.206954	360.35	1.70	362.05
18	-32.126758	149.204358	357.99	1.70	359.69
19	-32.128244	149.204310	358.31	1.70	360.01
20	-32.128194	149.203167	360.13	1.70	361.83
21	-32.133989	149.203058	359.90	1.70	361.60
22	-32.138704	149.203691	365.61	1.70	367.31
23	-32.145300	149.208283	369.63	1.70	371.33
24	-32.146181	149.209506	370.03	1.70	371.73
25	-32.147780	149.210665	370.12	1.70	371.82
26	-32.147239	149.211872	376.69	1.70	378.39
27	-32.148570	149.213036	377.70	1.70	379.40
28	-32.146889	149.217081	393.27	1.70	394.97
29	-32.146935	149.219098	401.21	1.70	402.91
30	-32.146208	149.220428	404.69	1.70	406.39
31	-32.144618	149.221898	408.43	1.70	410.13
32	-32.144046	149.221769	407.85	1.70	409.55
33	-32.143065	149.220428	399.91	1.70	401.61
34	-32.142266	149.221233	398.11	1.70	399.81
35	-32.142066	149.222767	394.46	1.70	396.16
36	-32.143210	149.226222	404.19	1.70	405.89
37	-32.142538	149.226479	397.91	1.70	399.61
38	-32.142157	149.227134	399.55	1.70	401.25
39	-32.135143	149.224988	384.47	1.70	386.17
40	-32.133199	149.224097	382.26	1.70	383.96
41	-32.132990	149.223711	380.56	1.70	382.26
42	-32.132663	149.224054	382.29	1.70	383.99
43	-32.131754	149.224001	381.06	1.70	382.76
44	-32.130700	149.223529	377.54	1.70	379.24
45	-32.130519	149.219698	370.91	1.70	372.61
46	-32.131645	149.216544	367.41	1.70	369.11
47	-32.131663	149.215053	367.91	1.70	369.61

**Name:** PV5

**Axis tracking:** Single-axis rotation

**Backtracking:** Shade-slope

**Tracking axis orientation:** 0.0°

**Max tracking angle:** 60.0°

**Resting angle:** 60.0°

**Ground Coverage Ratio:** 0.397

**Rated power:** -

**Panel material:** Smooth glass with AR coating

**Reflectivity:** Vary with sun

**Slope error:** correlate with material



Vertex	Latitude (°)	Longitude (°)	Ground elevation (m)	Height above ground (m)	Total elevation (m)
1	-32.151810	149.211278	364.47	1.70	366.17
2	-32.152896	149.211463	365.00	1.70	366.70
3	-32.154819	149.211139	365.47	1.70	367.17
4	-32.155145	149.211663	365.53	1.70	367.23
5	-32.156468	149.211403	365.15	1.70	366.85
6	-32.155492	149.206834	369.11	1.70	370.81
7	-32.153663	149.203560	367.20	1.70	368.90
8	-32.153889	149.203385	367.72	1.70	369.42
9	-32.150094	149.196763	373.32	1.70	375.02
10	-32.147167	149.197291	363.63	1.70	365.33
11	-32.146548	149.198222	362.87	1.70	364.57
12	-32.146594	149.199196	361.80	1.70	363.50
13	-32.146299	149.199434	361.07	1.70	362.77
14	-32.146957	149.202095	363.50	1.70	365.20
15	-32.147050	149.202336	364.26	1.70	365.96
16	-32.148164	149.203083	365.00	1.70	366.70
17	-32.149345	149.205309	364.79	1.70	366.49
18	-32.150451	149.208968	363.46	1.70	365.16
19	-32.151586	149.211328	364.15	1.70	365.85

**Name:** PV6

**Axis tracking:** Single-axis rotation

**Backtracking:** Shade-slope

**Tracking axis orientation:** 0.0°

**Max tracking angle:** 60.0°

**Resting angle:** 60.0°

**Ground Coverage Ratio:** 0.397

**Rated power:** -

**Panel material:** Smooth glass with AR coating

**Reflectivity:** Vary with sun

**Slope error:** correlate with material



Vertex	Latitude (°)	Longitude (°)	Ground elevation (m)	Height above ground (m)	Total elevation (m)
1	-32.150061	149.193300	377.63	1.70	379.33
2	-32.149660	149.194070	377.10	1.70	378.80
3	-32.148939	149.194361	376.90	1.70	378.60
4	-32.150740	149.196452	374.00	1.70	375.70
5	-32.154313	149.203379	367.94	1.70	369.64
6	-32.157014	149.199138	373.12	1.70	374.82
7	-32.156914	149.198407	373.01	1.70	374.71
8	-32.160698	149.197639	377.49	1.70	379.19
9	-32.161266	149.202031	374.19	1.70	375.89
10	-32.163738	149.198450	379.00	1.70	380.70
11	-32.162091	149.184836	406.15	1.70	407.85
12	-32.155165	149.185983	399.62	1.70	401.32
13	-32.155640	149.189530	390.00	1.70	391.70
14	-32.150146	149.192806	377.78	1.70	379.48

**Name:** PV7

**Axis tracking:** Single-axis rotation

**Backtracking:** Shade-slope

**Tracking axis orientation:** 0.0°

**Max tracking angle:** 60.0°

**Resting angle:** 60.0°

**Ground Coverage Ratio:** 0.397

**Rated power:** -

**Panel material:** Smooth glass with AR coating

**Reflectivity:** Vary with sun

**Slope error:** correlate with material



Vertex	Latitude (°)	Longitude (°)	Ground elevation (m)	Height above ground (m)	Total elevation (m)
1	-32.155903	149.201745	370.20	1.70	371.90
2	-32.154526	149.203738	367.73	1.70	369.43
3	-32.155848	149.205967	369.70	1.70	371.40
4	-32.157544	149.202754	372.02	1.70	373.72
5	-32.157915	149.202641	371.39	1.70	373.09
6	-32.157452	149.199595	373.50	1.70	375.20

**Name:** PV8

**Axis tracking:** Single-axis rotation

**Backtracking:** Shade-slope

**Tracking axis orientation:** 0.0°

**Max tracking angle:** 60.0°

**Resting angle:** 60.0°

**Ground Coverage Ratio:** 0.397

**Rated power:** -

**Panel material:** Smooth glass with AR coating

**Reflectivity:** Vary with sun

**Slope error:** correlate with material



Vertex	Latitude (°)	Longitude (°)	Ground elevation (m)	Height above ground (m)	Total elevation (m)
1	-32.154660	149.228959	400.00	1.70	401.70
2	-32.154542	149.228644	400.00	1.70	401.70
3	-32.154923	149.227854	400.00	1.70	401.70
4	-32.154780	149.227627	400.00	1.70	401.70
5	-32.155011	149.227537	400.00	1.70	401.70
6	-32.155494	149.225531	400.00	1.70	401.70
7	-32.154713	149.225134	400.00	1.70	401.70
8	-32.154621	149.224391	400.00	1.70	401.70
9	-32.154119	149.223167	400.00	1.70	401.70
10	-32.154067	149.221816	400.00	1.70	401.70
11	-32.153749	149.219704	400.00	1.70	401.70
12	-32.153775	149.219359	400.00	1.70	401.70
13	-32.154263	149.218431	400.00	1.70	401.70
14	-32.154160	149.217807	400.00	1.70	401.70
15	-32.154362	149.217092	400.00	1.70	401.70
16	-32.154667	149.216815	400.00	1.70	401.70
17	-32.155359	149.216762	400.00	1.70	401.70
18	-32.155543	149.216413	400.00	1.70	401.70
19	-32.155539	149.216007	400.00	1.70	401.70
20	-32.153292	149.214608	400.00	1.70	401.70
21	-32.152289	149.214439	400.00	1.70	401.70
22	-32.152046	149.218278	400.00	1.70	401.70
23	-32.152187	149.220989	400.00	1.70	401.70
24	-32.152631	149.222960	400.00	1.70	401.70
25	-32.152403	149.225933	400.00	1.70	401.70
26	-32.151938	149.227201	400.00	1.70	401.70
27	-32.151536	149.227575	400.00	1.70	401.70
28	-32.149519	149.231273	400.00	1.70	401.70
29	-32.151192	149.232572	400.00	1.70	401.70
30	-32.151649	149.232715	400.00	1.70	401.70
31	-32.151922	149.233083	400.00	1.70	401.70
32	-32.152420	149.233169	400.00	1.70	401.70
33	-32.152551	149.233453	400.00	1.70	401.70
34	-32.153427	149.234119	400.00	1.70	401.70
35	-32.154078	149.231413	400.00	1.70	401.70
36	-32.153966	149.231455	400.00	1.70	401.70
37	-32.153668	149.231015	400.00	1.70	401.70
38	-32.153590	149.230506	400.00	1.70	401.70
39	-32.154566	149.229389	400.00	1.70	401.70

# Route Receptors

**Name:** Danabar Road - unsealed  
**Path type:** Two-way  
**Observer view angle:** 50.0°



Vertex	Latitude (°)	Longitude (°)	Ground elevation (m)	Height above ground (m)	Total elevation (m)
1	-32.149296	149.211976	370.58	2.40	372.98
2	-32.147225	149.216890	395.35	2.40	397.75
3	-32.147093	149.217547	397.31	2.40	399.71
4	-32.147174	149.218599	400.89	2.40	403.29
5	-32.147047	149.219328	402.16	2.40	404.56
6	-32.146484	149.220423	404.28	2.40	406.68
7	-32.145021	149.221957	408.56	2.40	410.96
8	-32.144921	149.222515	410.71	2.40	413.11
9	-32.145103	149.223598	417.10	2.40	419.50
10	-32.145076	149.225079	419.66	2.40	422.06
11	-32.145476	149.226731	416.40	2.40	418.80
12	-32.145430	149.227364	414.62	2.40	417.02
13	-32.145085	149.228448	412.90	2.40	415.30

**Name:** Golden Highway  
**Path type:** Two-way  
**Observer view angle:** 50.0°



Vertex	Latitude (°)	Longitude (°)	Ground elevation (m)	Height above ground (m)	Total elevation (m)
1	-32.126963	149.173626	352.76	2.40	355.16
2	-32.126877	149.175069	348.86	2.40	351.26
3	-32.126593	149.176345	354.82	2.40	357.22
4	-32.126084	149.177713	356.35	2.40	358.75
5	-32.124939	149.179349	358.80	2.40	361.20
6	-32.123908	149.180245	360.69	2.40	363.09
7	-32.117370	149.183432	369.66	2.40	372.06
8	-32.115685	149.184698	366.55	2.40	368.95
9	-32.112950	149.187800	355.87	2.40	358.27
10	-32.110473	149.190739	352.83	2.40	355.23
11	-32.108524	149.193202	349.38	2.40	351.78
12	-32.107490	149.194924	348.01	2.40	350.41
13	-32.106645	149.197022	358.94	2.40	361.34
14	-32.106182	149.199205	361.96	2.40	364.36
15	-32.106044	149.200969	364.20	2.40	366.60
16	-32.106009	149.206300	365.86	2.40	368.26
17	-32.105881	149.225039	384.87	2.40	387.27
18	-32.105646	149.226821	388.31	2.40	390.71
19	-32.104815	149.229273	392.03	2.40	394.43
20	-32.103960	149.230657	396.17	2.40	398.57
21	-32.103024	149.231762	399.12	2.40	401.52
22	-32.102029	149.232625	402.51	2.40	404.91

Name: Sandy Creek Road - unsealed

Path type: Two-way

Observer view angle: 50.0°



Vertex	Latitude (°)	Longitude (°)	Ground elevation (m)	Height above ground (m)	Total elevation (m)
1	-32.106984	149.196187	353.25	2.40	355.65
2	-32.107993	149.196820	353.22	2.40	355.62
3	-32.108984	149.197818	350.15	2.40	352.55
4	-32.112500	149.200146	358.17	2.40	360.57
5	-32.122632	149.202377	358.00	2.40	360.40
6	-32.126857	149.202892	357.67	2.40	360.07
7	-32.131473	149.202844	358.48	2.40	360.88
8	-32.131845	149.202951	358.94	2.40	361.34
9	-32.133376	149.202774	359.57	2.40	361.97
10	-32.138417	149.203539	364.93	2.40	367.33
11	-32.139717	149.203989	366.12	2.40	368.52
12	-32.141763	149.205161	366.33	2.40	368.73
13	-32.142390	149.206105	368.47	2.40	370.87
14	-32.145668	149.208239	368.58	2.40	370.98
15	-32.146986	149.209322	368.20	2.40	370.60
16	-32.147685	149.210417	369.34	2.40	371.74
17	-32.149629	149.212283	370.78	2.40	373.18
18	-32.150274	149.213099	370.46	2.40	372.86
19	-32.150783	149.214097	369.47	2.40	371.87
20	-32.153353	149.214472	371.55	2.40	373.95
21	-32.155760	149.215974	378.63	2.40	381.03
22	-32.157332	149.217219	383.12	2.40	385.52
23	-32.158867	149.217165	375.88	2.40	378.28
24	-32.159820	149.216800	372.62	2.40	375.02
25	-32.162218	149.215116	372.19	2.40	374.59
26	-32.162881	149.214848	373.54	2.40	375.94
27	-32.167159	149.214472	380.02	2.40	382.42
28	-32.176720	149.220320	386.94	2.40	389.34
29	-32.179340	149.219969	379.48	2.40	381.88
30	-32.182037	149.221193	380.55	2.40	382.95

**Name:** Spring Ridge Road  
**Path type:** Two-way  
**Observer view angle:** 50.0°



Vertex	Latitude (°)	Longitude (°)	Ground elevation (m)	Height above ground (m)	Total elevation (m)
1	-32.104828	149.229248	392.09	2.40	394.49
2	-32.106237	149.230179	391.80	2.40	394.20
3	-32.106819	149.230394	390.11	2.40	392.51
4	-32.109965	149.230866	395.48	2.40	397.88
5	-32.113285	149.231417	395.38	2.40	397.78
6	-32.114625	149.231446	397.39	2.40	399.79
7	-32.118674	149.231157	401.92	2.40	404.32
8	-32.120650	149.230781	399.81	2.40	402.21
9	-32.125149	149.229704	389.01	2.40	391.41
10	-32.130792	149.224903	384.32	2.40	386.72
11	-32.131563	149.224511	382.83	2.40	385.23
12	-32.132415	149.224446	383.88	2.40	386.28
13	-32.142391	149.227525	400.92	2.40	403.32
14	-32.144852	149.228332	412.67	2.40	415.07
15	-32.145670	149.228847	412.08	2.40	414.48
16	-32.150439	149.232569	396.81	2.40	399.21
17	-32.154063	149.235256	408.27	2.40	410.67
18	-32.158748	149.238790	402.07	2.40	404.47
19	-32.163450	149.242340	393.36	2.40	395.76
20	-32.164090	149.242941	394.01	2.40	396.41
21	-32.171844	149.256105	394.31	2.40	396.71
22	-32.172943	149.256856	393.48	2.40	395.88
23	-32.174677	149.257240	398.00	2.40	400.40
24	-32.177456	149.259604	396.77	2.40	399.17
25	-32.178882	149.260816	398.58	2.40	400.98
26	-32.181788	149.262758	401.04	2.40	403.44
27	-32.185074	149.264927	401.90	2.40	404.30
28	-32.185705	149.265415	403.58	2.40	405.98
29	-32.187511	149.268668	399.89	2.40	402.29

Name: Sweeneys Lane - unsealed road

Path type: Two-way

Observer view angle: 50.0°



Vertex	Latitude (°)	Longitude (°)	Ground elevation (m)	Height above ground (m)	Total elevation (m)
1	-32.142306	149.186963	378.21	2.40	380.61
2	-32.142955	149.188025	376.20	2.40	378.60
3	-32.144241	149.189817	375.89	2.40	378.29
4	-32.145094	149.190659	378.36	2.40	380.76
5	-32.145794	149.191233	376.39	2.40	378.79
6	-32.146725	149.192359	376.71	2.40	379.11
7	-32.147620	149.193223	375.29	2.40	377.69
8	-32.150127	149.196302	375.26	2.40	377.66
9	-32.150590	149.196833	373.29	2.40	375.69
10	-32.154578	149.204301	366.73	2.40	369.13
11	-32.155995	149.206532	370.45	2.40	372.85
12	-32.156086	149.207734	369.74	2.40	372.14
13	-32.156594	149.209751	369.96	2.40	372.36
14	-32.158683	149.211371	368.33	2.40	370.73
15	-32.159133	149.211773	368.87	2.40	371.27
16	-32.159024	149.212100	368.93	2.40	371.33
17	-32.158279	149.212739	367.87	2.40	370.27
18	-32.157443	149.213710	371.69	2.40	374.09
19	-32.156980	149.214434	373.00	2.40	375.40
20	-32.155799	149.216011	378.85	2.40	381.25

Name: Tallawonga Road - unsealed

Path type: Two-way

Observer view angle: 50.0°



Vertex	Latitude (°)	Longitude (°)	Ground elevation (m)	Height above ground (m)	Total elevation (m)
1	-32.171558	149.187685	394.85	2.40	397.25
2	-32.167707	149.193070	391.00	2.40	393.40
3	-32.167244	149.193832	390.94	2.40	393.34
4	-32.163929	149.198403	378.90	2.40	381.30
5	-32.161386	149.202147	374.26	2.40	376.66
6	-32.161095	149.202126	374.00	2.40	376.40
7	-32.160977	149.201814	374.00	2.40	376.40
8	-32.160532	149.198263	375.57	2.40	377.97
9	-32.160214	149.197963	376.44	2.40	378.84
10	-32.158911	149.198056	375.58	2.40	377.98
11	-32.157521	149.198711	374.36	2.40	376.76
12	-32.156695	149.200127	371.56	2.40	373.96
13	-32.156486	149.200513	371.01	2.40	373.41
14	-32.155396	149.202176	369.72	2.40	372.12
15	-32.154278	149.203711	367.41	2.40	369.81

## Discrete Observation Point Receptors

Name	ID	Latitude (°)	Longitude (°)	Elevation (m)	Height (m)
OP 1	1	-32.178215	149.261931	397.83	1.50
OP 2	2	-32.126994	149.230023	397.48	1.50
OP 3	3	-32.103178	149.191769	348.91	1.50
OP 4	4	-32.131254	149.192732	365.89	1.50
OP 5	5	-32.159103	149.210782	367.69	1.50
OP 6	6	-32.162682	149.262090	394.72	1.50
OP 7	7	-32.100892	149.235197	403.29	1.50
OP 8	8	-32.110649	149.177765	362.67	1.50
OP 9	9	-32.153573	149.165308	394.70	1.50
OP 10	10	-32.161329	149.170663	392.05	1.50
OP 11	11	-32.166882	149.178194	410.65	1.50
OP 12	12	-32.192999	149.218406	384.39	1.50
OP 13	13	-32.113833	149.156535	348.76	1.50
OP 14	14	-32.186814	149.180864	408.35	1.50
OP 15	15	-32.203131	149.220235	388.20	1.50
OP 16	16	-32.208491	149.242015	445.52	1.50
OP 17	17	-32.189633	149.271344	396.92	1.50
OP 18	18	-32.200162	149.282783	408.94	1.50
OP 19	19	-32.114204	149.238579	432.16	1.50

# Glare Analysis Results

## Summary of Results Glare with low potential for temporary after-image predicted

PV Array	Tilt °	Orient °	Annual Green Glare		Annual Yellow Glare		Energy kWh
			min	hr	min	hr	
PV1	SA tracking	SA tracking	0	0.0	0	0.0	-
PV2	SA tracking	SA tracking	0	0.0	0	0.0	-
PV3	SA tracking	SA tracking	4,967	82.8	0	0.0	-
PV4	SA tracking	SA tracking	0	0.0	0	0.0	-
PV5	SA tracking	SA tracking	0	0.0	0	0.0	-
PV6	SA tracking	SA tracking	16,390	273.2	0	0.0	-
PV7	SA tracking	SA tracking	3,593	59.9	0	0.0	-
PV8	SA tracking	SA tracking	0	0.0	0	0.0	-

Total glare received by each receptor; may include duplicate times of glare from multiple reflective surfaces.

Receptor	Annual Green Glare		Annual Yellow Glare	
	min	hr	min	hr
Danabar Road - unsealed	0	0.0	0	0.0
Golden Highway	0	0.0	0	0.0
Sandy Creek Road - unsealed	0	0.0	0	0.0
Spring Ridge Road	4,967	82.8	0	0.0
Sweeneys Lane - unsealed road	3,593	59.9	0	0.0
Tallawonga Road - unsealed	16,390	273.2	0	0.0
OP 1	0	0.0	0	0.0
OP 2	0	0.0	0	0.0
OP 3	0	0.0	0	0.0
OP 4	0	0.0	0	0.0
OP 5	0	0.0	0	0.0
OP 6	0	0.0	0	0.0
OP 7	0	0.0	0	0.0
OP 8	0	0.0	0	0.0
OP 9	0	0.0	0	0.0

Receptor	Annual Green Glare		Annual Yellow Glare	
	min	hr	min	hr
OP 10	0	0.0	0	0.0
OP 11	0	0.0	0	0.0
OP 12	0	0.0	0	0.0
OP 13	0	0.0	0	0.0
OP 14	0	0.0	0	0.0
OP 15	0	0.0	0	0.0
OP 16	0	0.0	0	0.0
OP 17	0	0.0	0	0.0
OP 18	0	0.0	0	0.0
OP 19	0	0.0	0	0.0

**PV: PV1** no glare found

Receptor results ordered by category of glare

Receptor	Annual Green Glare		Annual Yellow Glare	
	min	hr	min	hr
Danabar Road - unsealed	0	0.0	0	0.0
Golden Highway	0	0.0	0	0.0
Sandy Creek Road - unsealed	0	0.0	0	0.0
Spring Ridge Road	0	0.0	0	0.0
Sweeneys Lane - unsealed road	0	0.0	0	0.0
Tallawonga Road - unsealed	0	0.0	0	0.0
OP 1	0	0.0	0	0.0
OP 2	0	0.0	0	0.0
OP 3	0	0.0	0	0.0
OP 4	0	0.0	0	0.0
OP 5	0	0.0	0	0.0
OP 6	0	0.0	0	0.0
OP 7	0	0.0	0	0.0
OP 8	0	0.0	0	0.0
OP 9	0	0.0	0	0.0
OP 10	0	0.0	0	0.0
OP 11	0	0.0	0	0.0
OP 12	0	0.0	0	0.0
OP 13	0	0.0	0	0.0
OP 14	0	0.0	0	0.0
OP 15	0	0.0	0	0.0
OP 16	0	0.0	0	0.0
OP 17	0	0.0	0	0.0
OP 18	0	0.0	0	0.0
OP 19	0	0.0	0	0.0

**PV1 and Route: Danabar Road - unsealed**

No glare found

**PV1 and Route: Golden Highway**

No glare found

**PV1 and Route: Sandy Creek Road - unsealed**

No glare found

**PV1 and Route: Spring Ridge Road**

No glare found

**PV1 and Route: Sweeneys Lane - unsealed road**

No glare found

**PV1 and Route: Tallawonga Road - unsealed**

No glare found

**PV1 and OP 1**

No glare found

**PV1 and OP 2**

No glare found

**PV1 and OP 3**

No glare found

**PV1 and OP 4**

No glare found

**PV1 and OP 5**

No glare found

**PV1 and OP 6**

No glare found

**PV1 and OP 7**

No glare found

**PV1 and OP 8**

No glare found

**PV1 and OP 9**

No glare found

**PV1 and OP 10**

No glare found

**PV1 and OP 11**

No glare found

**PV1 and OP 12**

No glare found

**PV1 and OP 13**

No glare found

**PV1 and OP 14**

No glare found

**PV1 and OP 15**

No glare found

**PV1 and OP 16**

No glare found

**PV1 and OP 17**

No glare found

**PV1 and OP 18**

No glare found

**PV1 and OP 19**

No glare found

**PV: PV2** no glare found

Receptor results ordered by category of glare

Receptor	Annual Green Glare		Annual Yellow Glare	
	min	hr	min	hr
Danabar Road - unsealed	0	0.0	0	0.0
Golden Highway	0	0.0	0	0.0
Sandy Creek Road - unsealed	0	0.0	0	0.0
Spring Ridge Road	0	0.0	0	0.0
Sweeneys Lane - unsealed road	0	0.0	0	0.0
Tallawonga Road - unsealed	0	0.0	0	0.0
OP 1	0	0.0	0	0.0
OP 2	0	0.0	0	0.0
OP 3	0	0.0	0	0.0
OP 4	0	0.0	0	0.0
OP 5	0	0.0	0	0.0
OP 6	0	0.0	0	0.0
OP 7	0	0.0	0	0.0
OP 8	0	0.0	0	0.0
OP 9	0	0.0	0	0.0
OP 10	0	0.0	0	0.0
OP 11	0	0.0	0	0.0
OP 12	0	0.0	0	0.0
OP 13	0	0.0	0	0.0
OP 14	0	0.0	0	0.0
OP 15	0	0.0	0	0.0
OP 16	0	0.0	0	0.0
OP 17	0	0.0	0	0.0
OP 18	0	0.0	0	0.0
OP 19	0	0.0	0	0.0

**PV2 and Route: Danabar Road - unsealed**

No glare found

**PV2 and Route: Golden Highway**

No glare found

**PV2 and Route: Sandy Creek Road - unsealed**

No glare found

**PV2 and Route: Spring Ridge Road**

No glare found

**PV2 and Route: Sweeneys Lane - unsealed road**

No glare found

**PV2 and Route: Tallawonga Road - unsealed**

No glare found

**PV2 and OP 1**

No glare found

**PV2 and OP 2**

No glare found

**PV2 and OP 3**

No glare found

**PV2 and OP 4**

No glare found

**PV2 and OP 5**

No glare found

**PV2 and OP 6**

No glare found

**PV2 and OP 7**

No glare found

**PV2 and OP 8**

No glare found

**PV2 and OP 9**

No glare found

**PV2 and OP 10**

No glare found

**PV2 and OP 11**

No glare found

**PV2 and OP 12**

No glare found

**PV2 and OP 13**

No glare found

**PV2 and OP 14**

No glare found

**PV2 and OP 15**

No glare found

**PV2 and OP 16**

No glare found

**PV2 and OP 17**

No glare found

**PV2 and OP 18**

No glare found

**PV2 and OP 19**

No glare found

**PV: PV3** low potential for temporary after-image

Receptor results ordered by category of glare

Receptor	Annual Green Glare		Annual Yellow Glare	
	min	hr	min	hr
Spring Ridge Road	4,967	82.8	0	0.0
Danabar Road - unsealed	0	0.0	0	0.0
Golden Highway	0	0.0	0	0.0
Sandy Creek Road - unsealed	0	0.0	0	0.0
Sweeneys Lane - unsealed road	0	0.0	0	0.0
Tallawonga Road - unsealed	0	0.0	0	0.0
OP 1	0	0.0	0	0.0
OP 2	0	0.0	0	0.0
OP 3	0	0.0	0	0.0
OP 4	0	0.0	0	0.0
OP 5	0	0.0	0	0.0
OP 6	0	0.0	0	0.0
OP 7	0	0.0	0	0.0
OP 8	0	0.0	0	0.0
OP 9	0	0.0	0	0.0
OP 10	0	0.0	0	0.0
OP 11	0	0.0	0	0.0
OP 12	0	0.0	0	0.0
OP 13	0	0.0	0	0.0
OP 14	0	0.0	0	0.0
OP 15	0	0.0	0	0.0
OP 16	0	0.0	0	0.0
OP 17	0	0.0	0	0.0
OP 18	0	0.0	0	0.0
OP 19	0	0.0	0	0.0

## PV3 and Route: Spring Ridge Road

Yellow glare: none  
 Green glare: 4,967 min.

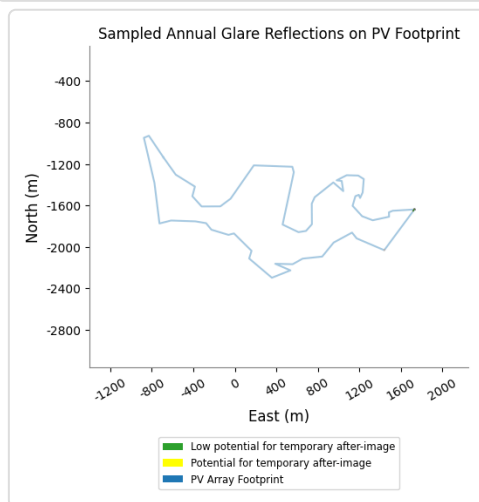
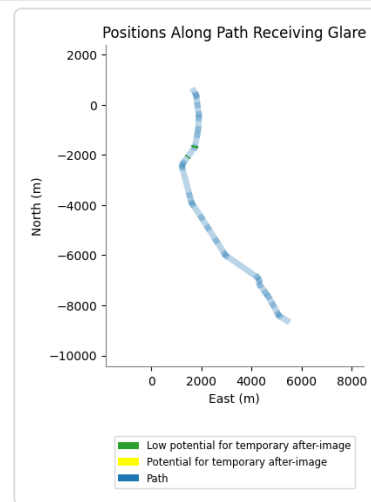
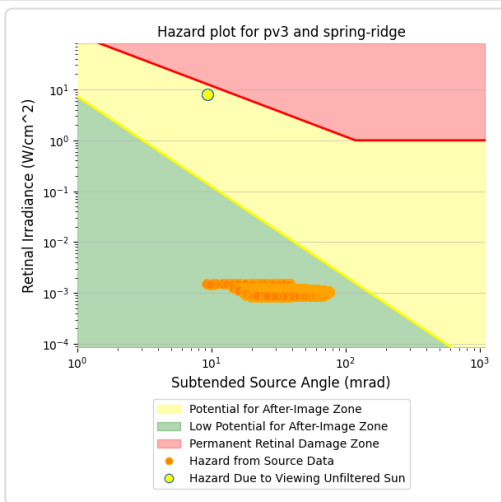
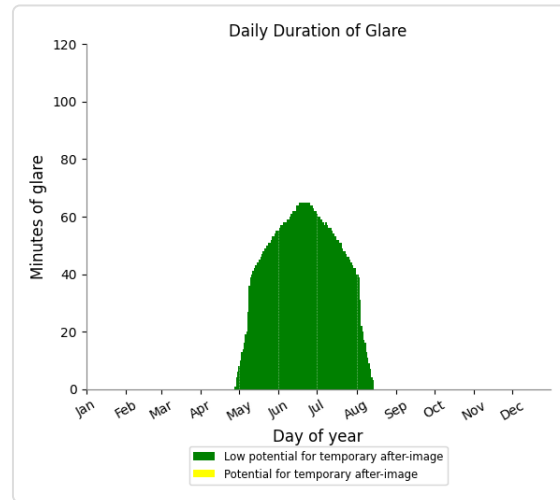
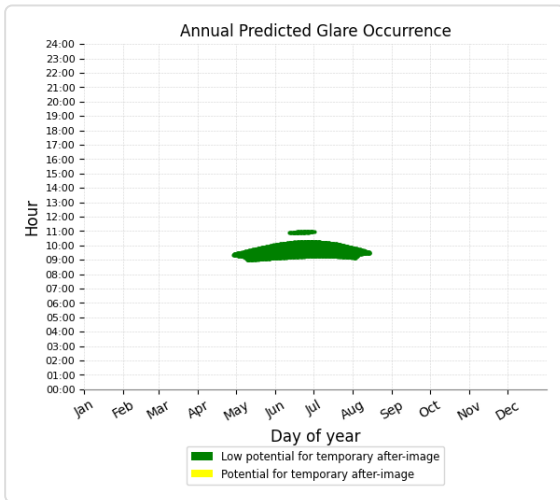

## PV3 and Route: Danabar Road - unsealed

No glare found

**PV3 and Route: Golden Highway**

No glare found

**PV3 and Route: Sandy Creek Road - unsealed**

No glare found

**PV3 and Route: Sweeneys Lane - unsealed road**

No glare found

**PV3 and Route: Tallawonga Road - unsealed**

No glare found

**PV3 and OP 1**

No glare found

**PV3 and OP 2**

No glare found

**PV3 and OP 3**

No glare found

**PV3 and OP 4**

No glare found

**PV3 and OP 5**

No glare found

**PV3 and OP 6**

No glare found

**PV3 and OP 7**

No glare found

**PV3 and OP 8**

No glare found

**PV3 and OP 9**

No glare found

**PV3 and OP 10**

No glare found

**PV3 and OP 11**

No glare found

**PV3 and OP 12**

No glare found

**PV3 and OP 13**

No glare found

**PV3 and OP 14**

No glare found

**PV3 and OP 15**

No glare found

**PV3 and OP 16**

No glare found

**PV3 and OP 17**

No glare found

**PV3 and OP 18**

No glare found

**PV3 and OP 19**

No glare found

**PV: PV4** no glare found

Receptor results ordered by category of glare

Receptor	Annual Green Glare		Annual Yellow Glare	
	min	hr	min	hr
Danabar Road - unsealed	0	0.0	0	0.0
Golden Highway	0	0.0	0	0.0
Sandy Creek Road - unsealed	0	0.0	0	0.0
Spring Ridge Road	0	0.0	0	0.0
Sweeneys Lane - unsealed road	0	0.0	0	0.0
Tallawonga Road - unsealed	0	0.0	0	0.0
OP 1	0	0.0	0	0.0
OP 2	0	0.0	0	0.0
OP 3	0	0.0	0	0.0
OP 4	0	0.0	0	0.0
OP 5	0	0.0	0	0.0
OP 6	0	0.0	0	0.0
OP 7	0	0.0	0	0.0
OP 8	0	0.0	0	0.0
OP 9	0	0.0	0	0.0
OP 10	0	0.0	0	0.0
OP 11	0	0.0	0	0.0
OP 12	0	0.0	0	0.0
OP 13	0	0.0	0	0.0
OP 14	0	0.0	0	0.0
OP 15	0	0.0	0	0.0
OP 16	0	0.0	0	0.0
OP 17	0	0.0	0	0.0
OP 18	0	0.0	0	0.0
OP 19	0	0.0	0	0.0

**PV4 and Route: Danabar Road - unsealed**

No glare found

**PV4 and Route: Golden Highway**

No glare found

**PV4 and Route: Sandy Creek Road - unsealed**

No glare found

**PV4 and Route: Spring Ridge Road**

No glare found

**PV4 and Route: Sweeneys Lane - unsealed road**

No glare found

**PV4 and Route: Tallawonga Road - unsealed**

No glare found

**PV4 and OP 1**

No glare found

**PV4 and OP 2**

No glare found

**PV4 and OP 3**

No glare found

**PV4 and OP 4**

No glare found

**PV4 and OP 5**

No glare found

**PV4 and OP 6**

No glare found

**PV4 and OP 7**

No glare found

**PV4 and OP 8**

No glare found

**PV4 and OP 9**

No glare found

**PV4 and OP 10**

No glare found

**PV4 and OP 11**

No glare found

**PV4 and OP 12**

No glare found

**PV4 and OP 13**

No glare found

**PV4 and OP 14**

No glare found

**PV4 and OP 15**

No glare found

**PV4 and OP 16**

No glare found

**PV4 and OP 17**

No glare found

**PV4 and OP 18**

No glare found

**PV4 and OP 19**

No glare found

**PV: PV5** no glare found

Receptor results ordered by category of glare

Receptor	Annual Green Glare		Annual Yellow Glare	
	min	hr	min	hr
Danabar Road - unsealed	0	0.0	0	0.0
Golden Highway	0	0.0	0	0.0
Sandy Creek Road - unsealed	0	0.0	0	0.0
Spring Ridge Road	0	0.0	0	0.0
Sweeneys Lane - unsealed road	0	0.0	0	0.0
Tallawonga Road - unsealed	0	0.0	0	0.0
OP 1	0	0.0	0	0.0
OP 2	0	0.0	0	0.0
OP 3	0	0.0	0	0.0
OP 4	0	0.0	0	0.0
OP 5	0	0.0	0	0.0
OP 6	0	0.0	0	0.0
OP 7	0	0.0	0	0.0
OP 8	0	0.0	0	0.0
OP 9	0	0.0	0	0.0
OP 10	0	0.0	0	0.0
OP 11	0	0.0	0	0.0
OP 12	0	0.0	0	0.0
OP 13	0	0.0	0	0.0
OP 14	0	0.0	0	0.0
OP 15	0	0.0	0	0.0
OP 16	0	0.0	0	0.0
OP 17	0	0.0	0	0.0
OP 18	0	0.0	0	0.0
OP 19	0	0.0	0	0.0

**PV5 and Route: Danabar Road - unsealed**

No glare found

**PV5 and Route: Golden Highway**

No glare found

**PV5 and Route: Sandy Creek Road - unsealed**

No glare found

**PV5 and Route: Spring Ridge Road**

No glare found

**PV5 and Route: Sweeneys Lane - unsealed road**

No glare found

**PV5 and Route: Tallawonga Road - unsealed**

No glare found

**PV5 and OP 1**

No glare found

**PV5 and OP 2**

No glare found

**PV5 and OP 3**

No glare found

**PV5 and OP 4**

No glare found

**PV5 and OP 5**

No glare found

**PV5 and OP 6**

No glare found

**PV5 and OP 7**

No glare found

**PV5 and OP 8**

No glare found

**PV5 and OP 9**

No glare found

**PV5 and OP 10**

No glare found

**PV5 and OP 11**

No glare found

**PV5 and OP 12**

No glare found

**PV5 and OP 13**

No glare found

**PV5 and OP 14**

No glare found

**PV5 and OP 15**

No glare found

**PV5 and OP 16**

No glare found

**PV5 and OP 17**

No glare found

**PV5 and OP 18**

No glare found

**PV5 and OP 19**

No glare found

**PV: PV6** low potential for temporary after-image

Receptor results ordered by category of glare

Receptor	Annual Green Glare		Annual Yellow Glare	
	min	hr	min	hr
Tallawonga Road - unsealed	16,390	273.2	0	0.0
Danabar Road - unsealed	0	0.0	0	0.0
Golden Highway	0	0.0	0	0.0
Sandy Creek Road - unsealed	0	0.0	0	0.0
Spring Ridge Road	0	0.0	0	0.0
Sweeneys Lane - unsealed road	0	0.0	0	0.0
OP 1	0	0.0	0	0.0
OP 2	0	0.0	0	0.0
OP 3	0	0.0	0	0.0
OP 4	0	0.0	0	0.0
OP 5	0	0.0	0	0.0
OP 6	0	0.0	0	0.0
OP 7	0	0.0	0	0.0
OP 8	0	0.0	0	0.0
OP 9	0	0.0	0	0.0
OP 10	0	0.0	0	0.0
OP 11	0	0.0	0	0.0
OP 12	0	0.0	0	0.0
OP 13	0	0.0	0	0.0
OP 14	0	0.0	0	0.0
OP 15	0	0.0	0	0.0
OP 16	0	0.0	0	0.0
OP 17	0	0.0	0	0.0
OP 18	0	0.0	0	0.0
OP 19	0	0.0	0	0.0

## PV6 and Route: Tallawonga Road - unsealed

Yellow glare: none  
Green glare: 16,390 min.

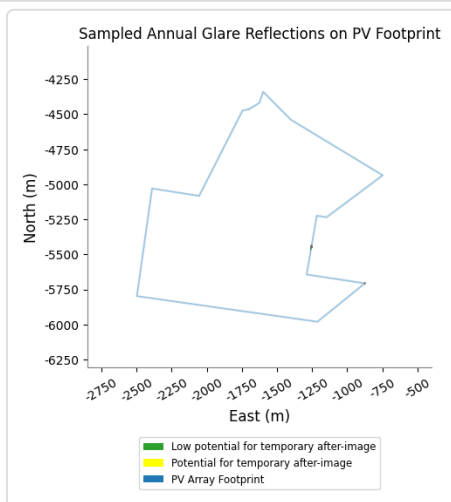
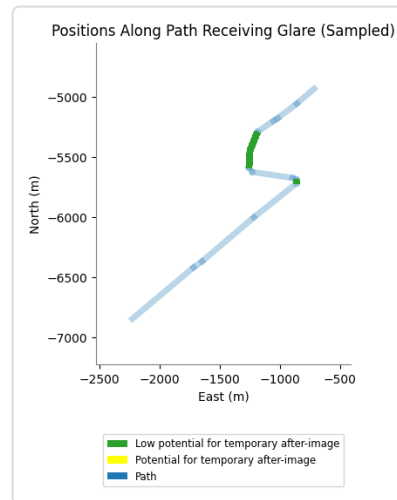
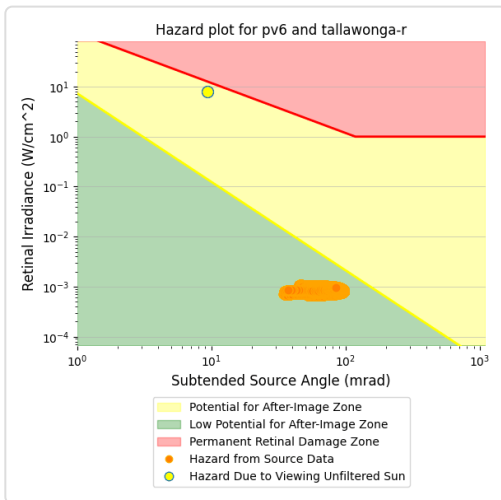
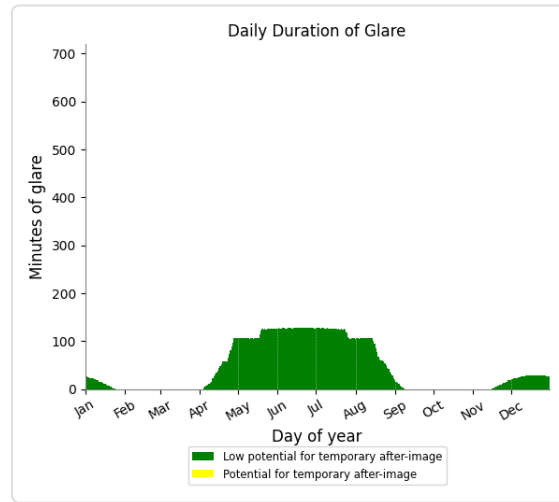
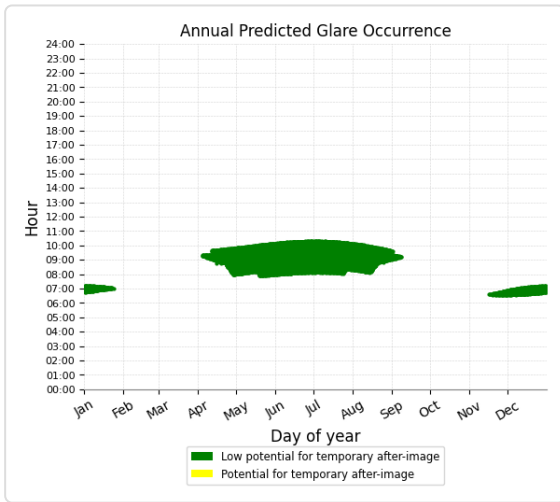

## PV6 and Route: Danabar Road - unsealed

No glare found

**PV6 and Route: Golden Highway**

No glare found

**PV6 and Route: Sandy Creek Road - unsealed**

No glare found

**PV6 and Route: Spring Ridge Road**

No glare found

**PV6 and Route: Sweeneys Lane - unsealed road**

No glare found

**PV6 and OP 1**

No glare found

**PV6 and OP 2**

No glare found

**PV6 and OP 3**

No glare found

**PV6 and OP 4**

No glare found

**PV6 and OP 5**

No glare found

**PV6 and OP 6**

No glare found

**PV6 and OP 7**

No glare found

**PV6 and OP 8**

No glare found

**PV6 and OP 9**

No glare found

**PV6 and OP 10**

No glare found

**PV6 and OP 11**

No glare found

**PV6 and OP 12**

No glare found

**PV6 and OP 13**

No glare found

**PV6 and OP 14**

No glare found

**PV6 and OP 15**

No glare found

**PV6 and OP 16**

No glare found

**PV6 and OP 17**

No glare found

**PV6 and OP 18**

No glare found

**PV6 and OP 19**

No glare found

**PV: PV7** low potential for temporary after-image

Receptor results ordered by category of glare

Receptor	Annual Green Glare		Annual Yellow Glare	
	min	hr	min	hr
Sweeneys Lane - unsealed road	3,593	59.9	0	0.0
Danabar Road - unsealed	0	0.0	0	0.0
Golden Highway	0	0.0	0	0.0
Sandy Creek Road - unsealed	0	0.0	0	0.0
Spring Ridge Road	0	0.0	0	0.0
Tallawonga Road - unsealed	0	0.0	0	0.0
OP 1	0	0.0	0	0.0
OP 2	0	0.0	0	0.0
OP 3	0	0.0	0	0.0
OP 4	0	0.0	0	0.0
OP 5	0	0.0	0	0.0
OP 6	0	0.0	0	0.0
OP 7	0	0.0	0	0.0
OP 8	0	0.0	0	0.0
OP 9	0	0.0	0	0.0
OP 10	0	0.0	0	0.0
OP 11	0	0.0	0	0.0
OP 12	0	0.0	0	0.0
OP 13	0	0.0	0	0.0
OP 14	0	0.0	0	0.0
OP 15	0	0.0	0	0.0
OP 16	0	0.0	0	0.0
OP 17	0	0.0	0	0.0
OP 18	0	0.0	0	0.0
OP 19	0	0.0	0	0.0

## PV7 and Route: Sweeneys Lane - unsealed road

Yellow glare: none

Green glare: 3,593 min.

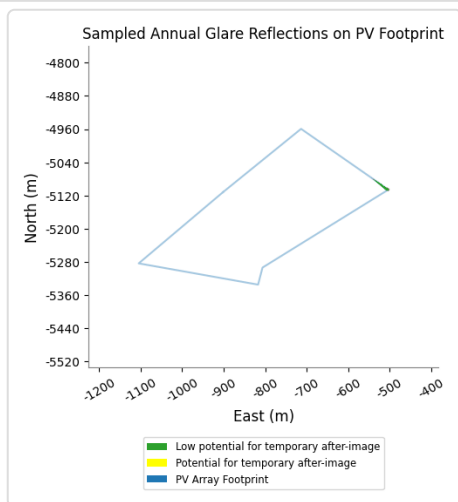
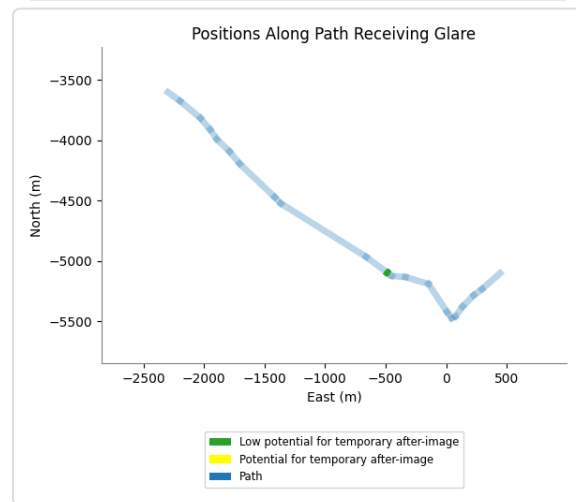
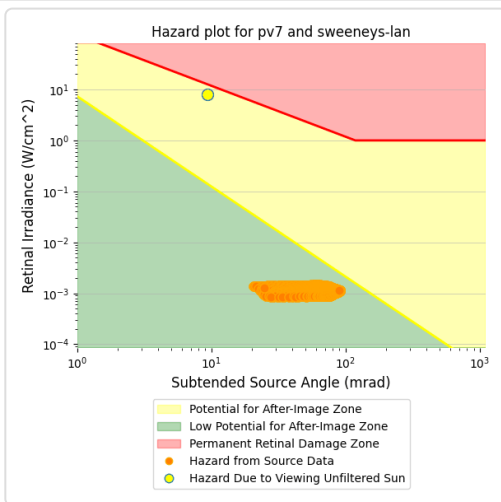
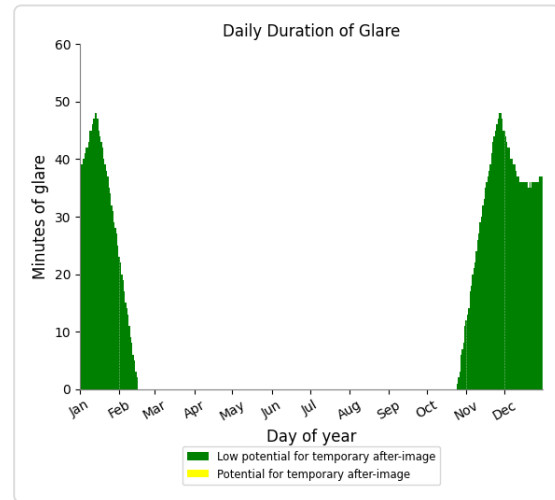
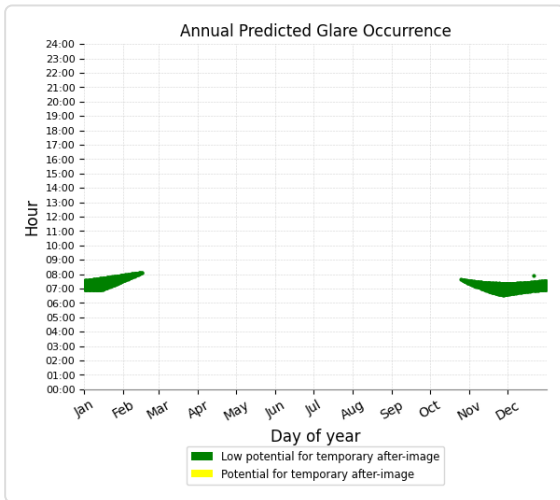

## PV7 and Route: Danabar Road - unsealed

No glare found

**PV7 and Route: Golden Highway**

No glare found

**PV7 and Route: Sandy Creek Road - unsealed**

No glare found

**PV7 and Route: Spring Ridge Road**

No glare found

**PV7 and Route: Tallawonga Road - unsealed**

No glare found

**PV7 and OP 1**

No glare found

**PV7 and OP 2**

No glare found

**PV7 and OP 3**

No glare found

**PV7 and OP 4**

No glare found

**PV7 and OP 5**

No glare found

**PV7 and OP 6**

No glare found

**PV7 and OP 7**

No glare found

**PV7 and OP 8**

No glare found

**PV7 and OP 9**

No glare found

**PV7 and OP 10**

No glare found

**PV7 and OP 11**

No glare found

**PV7 and OP 12**

No glare found

**PV7 and OP 13**

No glare found

**PV7 and OP 14**

No glare found

**PV7 and OP 15**

No glare found

**PV7 and OP 16**

No glare found

**PV7 and OP 17**

No glare found

**PV7 and OP 18**

No glare found

**PV7 and OP 19**

No glare found

**PV: PV8** no glare found

Receptor results ordered by category of glare

Receptor	Annual Green Glare		Annual Yellow Glare	
	min	hr	min	hr
Danabar Road - unsealed	0	0.0	0	0.0
Golden Highway	0	0.0	0	0.0
Sandy Creek Road - unsealed	0	0.0	0	0.0
Spring Ridge Road	0	0.0	0	0.0
Sweeneys Lane - unsealed road	0	0.0	0	0.0
Tallawonga Road - unsealed	0	0.0	0	0.0
OP 1	0	0.0	0	0.0
OP 2	0	0.0	0	0.0
OP 3	0	0.0	0	0.0
OP 4	0	0.0	0	0.0
OP 5	0	0.0	0	0.0
OP 6	0	0.0	0	0.0
OP 7	0	0.0	0	0.0
OP 8	0	0.0	0	0.0
OP 9	0	0.0	0	0.0
OP 10	0	0.0	0	0.0
OP 11	0	0.0	0	0.0
OP 12	0	0.0	0	0.0
OP 13	0	0.0	0	0.0
OP 14	0	0.0	0	0.0
OP 15	0	0.0	0	0.0
OP 16	0	0.0	0	0.0
OP 17	0	0.0	0	0.0
OP 18	0	0.0	0	0.0
OP 19	0	0.0	0	0.0

**PV8 and Route: Danabar Road - unsealed**

No glare found

**PV8 and Route: Golden Highway**

No glare found

**PV8 and Route: Sandy Creek Road - unsealed**

No glare found

**PV8 and Route: Spring Ridge Road**

No glare found

**PV8 and Route: Sweeneys Lane - unsealed road**

No glare found

**PV8 and Route: Tallawonga Road - unsealed**

No glare found

**PV8 and OP 1**

No glare found

**PV8 and OP 2**

No glare found

**PV8 and OP 3**

No glare found

**PV8 and OP 4**

No glare found

**PV8 and OP 5**

No glare found

**PV8 and OP 6**

No glare found

**PV8 and OP 7**

No glare found

**PV8 and OP 8**

No glare found

**PV8 and OP 9**

No glare found

**PV8 and OP 10**

No glare found

**PV8 and OP 11**

No glare found

**PV8 and OP 12**

No glare found

**PV8 and OP 13**

No glare found

**PV8 and OP 14**

No glare found

**PV8 and OP 15**

No glare found

**PV8 and OP 16**

No glare found

**PV8 and OP 17**

No glare found

**PV8 and OP 18**

No glare found

**PV8 and OP 19**

No glare found

# Assumptions

---

"Green" glare is glare with low potential to cause an after-image (flash blindness) when observed prior to a typical blink response time.

"Yellow" glare is glare with potential to cause an after-image (flash blindness) when observed prior to a typical blink response time.

Times associated with glare are denoted in Standard time. For Daylight Savings, add one hour.

The algorithm does not rigorously represent the detailed geometry of a system; detailed features such as gaps between modules, variable height of the PV array, and support structures may impact actual glare results. However, we have validated our models against several systems, including a PV array causing glare to the air-traffic control tower at Manchester-Boston Regional Airport and several sites in Albuquerque, and the tool accurately predicted the occurrence and intensity of glare at different times and days of the year.

Several V1 calculations utilize the PV array centroid, rather than the actual glare spot location, due to algorithm limitations. This may affect results for large PV footprints. Additional analyses of array sub-sections can provide additional information on expected glare. This primarily affects V1 analyses of path receptors.

Random number computations are utilized by various steps of the annual hazard analysis algorithm. Predicted minutes of glare can vary between runs as a result. This limitation primarily affects analyses of Observation Point receptors, including ATCTs. Note that the SGHAT/ ForgeSolar methodology has always relied on an analytical, qualitative approach to accurately determine the overall hazard (i.e. green vs. yellow) of expected glare on an annual basis.

The analysis does not automatically consider obstacles (either man-made or natural) between the observation points and the prescribed solar installation that may obstruct observed glare, such as trees, hills, buildings, etc.

The subtended source angle (glare spot size) is constrained by the PV array footprint size. Partitioning large arrays into smaller sections will reduce the maximum potential subtended angle, potentially impacting results if actual glare spots are larger than the sub-array size. Additional analyses of the combined area of adjacent sub-arrays can provide more information on potential glare hazards. (See previous point on related limitations.)

The variable direct normal irradiance (DNI) feature (if selected) scales the user-prescribed peak DNI using a typical clear-day irradiance profile. This profile has a lower DNI in the mornings and evenings and a maximum at solar noon. The scaling uses a clear-day irradiance profile based on a normalized time relative to sunrise, solar noon, and sunset, which are prescribed by a sun-position algorithm and the latitude and longitude obtained from Google maps. The actual DNI on any given day can be affected by cloud cover, atmospheric attenuation, and other environmental factors.

The ocular hazard predicted by the tool depends on a number of environmental, optical, and human factors, which can be uncertain. We provide input fields and typical ranges of values for these factors so that the user can vary these parameters to see if they have an impact on the results. The speed of SGHAT allows expedited sensitivity and parametric analyses.

The system output calculation is a DNI-based approximation that assumes clear, sunny skies year-round. It should not be used in place of more rigorous modeling methods.

Hazard zone boundaries shown in the Glare Hazard plot are an approximation and visual aid based on aggregated research data. Actual ocular impact outcomes encompass a continuous, not discrete, spectrum.

Glare locations displayed on receptor plots are approximate. Actual glare-spot locations may differ.

Refer to the Help page at [www.forgesolar.com/help/](http://www.forgesolar.com/help/) for assumptions and limitations not listed here.

Default glare analysis parameters and observer eye characteristics (for reference only):

- Analysis time interval: 1 minute
- Ocular transmission coefficient: 0.5
- Pupil diameter: 0.002 meters
- Eye focal length: 0.017 meters
- Sun subtended angle: 9.3 milliradians

© Sims Industries d/b/a ForgeSolar, All Rights Reserved.

# FORGESOLAR GLARE ANALYSIS

Project: 2490 COBBORA SOLAR FARM Part B South

Site configuration: 2490 COBBORA SOLAR FARM \_Part B \_South \_60d\_v02

Created 16 Mar, 2025

Updated 16 Mar, 2025

Time-step 1 minute

Timezone offset UTC10

Minimum sun altitude 0.0 deg

DNI peaks at 1,000.0 W/m<sup>2</sup>

Category 100 MW to 1 GW

Site ID 144255.22035

Ocular transmission coefficient 0.5

Pupil diameter 0.002 m

Eye focal length 0.017 m

Sun subtended angle 9.3 mrad

PV analysis methodology V2



## Summary of Results No glare predicted

PV Array	Tilt °	Orient °	Annual Green Glare		Annual Yellow Glare		Energy kWh
			min	hr	min	hr	
PV11	SA tracking	SA tracking	0	0.0	0	0.0	-

Total glare received by each receptor; may include duplicate times of glare from multiple reflective surfaces.

Receptor	Annual Green Glare		Annual Yellow Glare	
	min	hr	min	hr
Golden Highway	0	0.0	0	0.0
Sandy Creek Road - unsealed	0	0.0	0	0.0
Spring Ridge Road	0	0.0	0	0.0
OP 1	0	0.0	0	0.0
OP 2	0	0.0	0	0.0
OP 3	0	0.0	0	0.0
OP 4	0	0.0	0	0.0
OP 5	0	0.0	0	0.0
OP 6	0	0.0	0	0.0
OP 7	0	0.0	0	0.0
OP 8	0	0.0	0	0.0
OP 9	0	0.0	0	0.0
OP 10	0	0.0	0	0.0
OP 11	0	0.0	0	0.0
OP 12	0	0.0	0	0.0

Receptor	Annual Green Glare		Annual Yellow Glare	
	min	hr	min	hr
OP 13	0	0.0	0	0.0
OP 14	0	0.0	0	0.0
OP 15	0	0.0	0	0.0
OP 16	0	0.0	0	0.0
OP 17	0	0.0	0	0.0
OP 18	0	0.0	0	0.0
OP 19	0	0.0	0	0.0

# Component Data

---

## PV Arrays

**Name:** PV11

**Axis tracking:** Single-axis rotation

**Backtracking:** Shade-slope

**Tracking axis orientation:** 180.0°

**Max tracking angle:** 60.0°

**Resting angle:** 60.0°

**Ground Coverage Ratio:** 0.397

**Rated power:** -

**Panel material:** Smooth glass without AR coating

**Reflectivity:** Vary with sun

**Slope error:** correlate with material

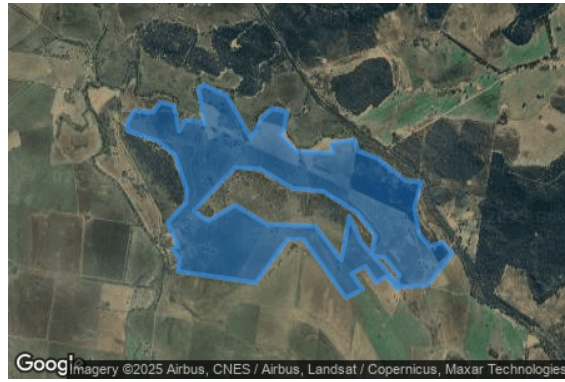

Vertex	Latitude (°)	Longitude (°)	Ground elevation (m)	Height above ground (m)	Total elevation (m)
1	-32.186062	149.245696	402.95	1.70	404.65
2	-32.185032	149.247994	401.91	1.70	403.61
3	-32.183271	149.246465	399.40	1.70	401.10
4	-32.182367	149.248353	404.35	1.70	406.05
5	-32.184265	149.249780	406.95	1.70	408.65
6	-32.183638	149.251186	411.15	1.70	412.85
7	-32.185046	149.252742	407.16	1.70	408.86
8	-32.184801	149.253171	407.17	1.70	408.87
9	-32.179525	149.247763	410.75	1.70	412.45
10	-32.176601	149.246122	410.46	1.70	412.16
11	-32.181632	149.245038	399.70	1.70	401.40
12	-32.177700	149.241444	390.34	1.70	392.04
13	-32.177518	149.234846	407.82	1.70	409.52
14	-32.175275	149.230468	401.90	1.70	403.60
15	-32.177091	149.226756	402.37	1.70	404.07
16	-32.175947	149.224793	400.27	1.70	401.97
17	-32.170934	149.230436	391.09	1.70	392.79
18	-32.171116	149.233870	390.80	1.70	392.50
19	-32.173332	149.238301	391.77	1.70	393.47
20	-32.173704	149.242528	392.99	1.70	394.69
21	-32.176156	149.247195	408.60	1.70	410.30
22	-32.178826	149.249705	410.76	1.70	412.46
23	-32.180823	149.249169	408.24	1.70	409.94
24	-32.181296	149.249641	406.94	1.70	408.64
25	-32.181268	149.250918	405.82	1.70	407.52
26	-32.183393	149.253021	406.06	1.70	407.76
27	-32.184238	149.252677	408.04	1.70	409.74
28	-32.184791	149.253181	407.15	1.70	408.85
29	-32.184583	149.256915	398.34	1.70	400.04
30	-32.180914	149.260391	393.47	1.70	395.17
31	-32.179570	149.258954	391.12	1.70	392.82
32	-32.179997	149.257194	391.06	1.70	392.76
33	-32.178580	149.255756	390.40	1.70	392.10
34	-32.175575	149.255113	389.47	1.70	391.17
35	-32.172660	149.256078	392.26	1.70	393.96
36	-32.172378	149.253739	391.21	1.70	392.91
37	-32.169917	149.250188	388.95	1.70	390.65
38	-32.168972	149.247345	384.93	1.70	386.63
39	-32.167646	149.246873	386.22	1.70	387.92
40	-32.168155	149.243558	382.91	1.70	384.61
41	-32.169236	149.243890	382.97	1.70	384.67
42	-32.169054	149.238869	380.08	1.70	381.78
43	-32.167065	149.236616	378.40	1.70	380.10
44	-32.166729	149.237163	378.12	1.70	379.82
45	-32.164431	149.237582	379.17	1.70	380.87
46	-32.164068	149.235490	380.40	1.70	382.10
47	-32.165131	149.234159	377.14	1.70	378.84
48	-32.167447	149.232571	378.57	1.70	380.27
49	-32.162579	149.229310	377.63	1.70	379.33
50	-32.161316	149.226166	375.87	1.70	377.57
51	-32.161734	149.225383	375.89	1.70	377.59
52	-32.165885	149.226209	377.43	1.70	379.13
53	-32.165394	149.224675	373.78	1.70	375.48
54	-32.165530	149.223527	375.65	1.70	377.35
55	-32.166684	149.222744	380.80	1.70	382.50
56	-32.163778	149.222111	371.95	1.70	373.65
57	-32.163314	149.220169	370.84	1.70	372.54
58	-32.164486	149.219128	373.76	1.70	375.46
59	-32.164368	149.216500	372.56	1.70	374.26



## Route Receptors

**Name:** Golden Highway  
**Path type:** Two-way  
**Observer view angle:** 50.0°



Vertex	Latitude (°)	Longitude (°)	Ground elevation (m)	Height above ground (m)	Total elevation (m)
1	-32.126963	149.173626	352.80	2.40	355.20
2	-32.126877	149.175069	348.90	2.40	351.30
3	-32.126593	149.176345	354.80	2.40	357.20
4	-32.126084	149.177713	356.30	2.40	358.70
5	-32.124939	149.179349	358.80	2.40	361.20
6	-32.123908	149.180245	360.70	2.40	363.10
7	-32.117370	149.183432	369.70	2.40	372.10
8	-32.115685	149.184698	366.50	2.40	368.90
9	-32.112950	149.187800	355.90	2.40	358.30
10	-32.110473	149.190739	352.80	2.40	355.20
11	-32.108524	149.193202	349.40	2.40	351.80
12	-32.107490	149.194924	348.00	2.40	350.40
13	-32.106645	149.197022	358.90	2.40	361.30
14	-32.106182	149.199205	362.00	2.40	364.40
15	-32.106044	149.200969	364.20	2.40	366.60
16	-32.106009	149.206300	365.90	2.40	368.30
17	-32.105881	149.225039	384.90	2.40	387.30
18	-32.105646	149.226821	388.30	2.40	390.70
19	-32.104815	149.229273	392.00	2.40	394.40
20	-32.103960	149.230657	396.20	2.40	398.60
21	-32.103024	149.231762	399.10	2.40	401.50
22	-32.102029	149.232625	402.50	2.40	404.90

Name: Sandy Creek Road - unsealed

Path type: Two-way

Observer view angle: 50.0°



Vertex	Latitude (°)	Longitude (°)	Ground elevation (m)	Height above ground (m)	Total elevation (m)
1	-32.138904	149.203703	366.09	2.40	368.49
2	-32.141630	149.205012	365.80	2.40	368.20
3	-32.142357	149.206128	368.54	2.40	370.94
4	-32.146826	149.209132	368.09	2.40	370.49
5	-32.147734	149.210484	369.48	2.40	371.88
6	-32.150205	149.212887	370.35	2.40	372.75
7	-32.150859	149.213960	368.87	2.40	371.27
8	-32.153439	149.214496	371.67	2.40	374.07
9	-32.155837	149.215998	378.84	2.40	381.24
10	-32.157454	149.217329	383.39	2.40	385.79
11	-32.159470	149.217093	373.75	2.40	376.15
12	-32.161713	149.215387	371.51	2.40	373.91
13	-32.162921	149.214840	373.60	2.40	376.00
14	-32.167154	149.214496	380.05	2.40	382.45
15	-32.168089	149.214925	379.82	2.40	382.22
16	-32.176626	149.220311	387.23	2.40	389.63
17	-32.177171	149.220376	385.50	2.40	387.90
18	-32.179332	149.219968	379.48	2.40	381.88
19	-32.179650	149.220097	380.07	2.40	382.47
20	-32.182056	149.221186	380.54	2.40	382.94
21	-32.183341	149.220724	378.42	2.40	380.82
22	-32.185184	149.220660	378.45	2.40	380.85
23	-32.187817	149.219619	381.70	2.40	384.10
24	-32.193383	149.218804	387.25	2.40	389.65
25	-32.194255	149.218954	386.69	2.40	389.09
26	-32.198594	149.218847	388.84	2.40	391.24
27	-32.199747	149.219533	386.54	2.40	388.94
28	-32.200864	149.221078	389.76	2.40	392.16

**Name:** Spring Ridge Road  
**Path type:** Two-way  
**Observer view angle:** 50.0°



Vertex	Latitude (°)	Longitude (°)	Ground elevation (m)	Height above ground (m)	Total elevation (m)
1	-32.104828	149.229248	392.10	2.40	394.50
2	-32.106237	149.230179	391.80	2.40	394.20
3	-32.106819	149.230394	390.10	2.40	392.50
4	-32.109965	149.230866	395.50	2.40	397.90
5	-32.113285	149.231417	395.40	2.40	397.80
6	-32.114625	149.231446	397.40	2.40	399.80
7	-32.118674	149.231157	401.90	2.40	404.30
8	-32.120650	149.230781	399.80	2.40	402.20
9	-32.125149	149.229704	389.00	2.40	391.40
10	-32.130792	149.224903	384.30	2.40	386.70
11	-32.131563	149.224511	382.80	2.40	385.20
12	-32.132415	149.224446	383.90	2.40	386.30
13	-32.142391	149.227525	400.90	2.40	403.30
14	-32.144852	149.228332	412.70	2.40	415.10
15	-32.145670	149.228847	412.10	2.40	414.50
16	-32.150439	149.232569	396.80	2.40	399.20
17	-32.154063	149.235256	408.30	2.40	410.70
18	-32.158748	149.238790	402.10	2.40	404.50
19	-32.163450	149.242340	393.40	2.40	395.80
20	-32.164090	149.242941	394.00	2.40	396.40
21	-32.171844	149.256105	394.30	2.40	396.70
22	-32.172943	149.256856	393.50	2.40	395.90
23	-32.174677	149.257240	398.00	2.40	400.40
24	-32.177456	149.259604	396.80	2.40	399.20
25	-32.178882	149.260816	398.60	2.40	401.00
26	-32.181788	149.262758	401.00	2.40	403.40
27	-32.185074	149.264927	401.90	2.40	404.30
28	-32.185705	149.265415	403.60	2.40	406.00
29	-32.187511	149.268668	399.90	2.40	402.30

## Discrete Observation Point Receptors

Name	ID	Latitude (°)	Longitude (°)	Elevation (m)	Height (m)
OP 1	1	-32.178215	149.261931	397.83	1.50
OP 2	2	-32.126994	149.230023	397.48	1.50
OP 3	3	-32.103178	149.191769	348.91	1.50
OP 4	4	-32.131254	149.192732	365.89	1.50
OP 5	5	-32.159103	149.210782	367.69	1.50
OP 6	6	-32.162682	149.262090	394.72	1.50
OP 7	7	-32.100892	149.235197	403.29	1.50
OP 8	8	-32.110649	149.177765	362.67	1.50
OP 9	9	-32.153573	149.165308	394.70	1.50
OP 10	10	-32.161329	149.170663	392.05	1.50
OP 11	11	-32.166882	149.178194	410.65	1.50
OP 12	12	-32.192999	149.218406	384.39	1.50
OP 13	13	-32.113833	149.156535	348.76	1.50
OP 14	14	-32.186814	149.180864	408.35	1.50
OP 15	15	-32.203131	149.220235	388.20	1.50
OP 16	16	-32.208491	149.242015	445.52	1.50
OP 17	17	-32.189633	149.271344	396.92	1.50
OP 18	18	-32.200162	149.282783	408.94	1.50
OP 19	19	-32.114204	149.238579	432.16	1.50

# Glare Analysis Results

## Summary of Results No glare predicted

PV Array	Tilt	Orient	Annual Green Glare		Annual Yellow Glare		Energy
	°	°	min	hr	min	hr	kWh
PV11	SA tracking	SA tracking	0	0.0	0	0.0	-

Total glare received by each receptor; may include duplicate times of glare from multiple reflective surfaces.

Receptor	Annual Green Glare		Annual Yellow Glare	
	min	hr	min	hr
Golden Highway	0	0.0	0	0.0
Sandy Creek Road - unsealed	0	0.0	0	0.0
Spring Ridge Road	0	0.0	0	0.0
OP 1	0	0.0	0	0.0
OP 2	0	0.0	0	0.0
OP 3	0	0.0	0	0.0
OP 4	0	0.0	0	0.0
OP 5	0	0.0	0	0.0
OP 6	0	0.0	0	0.0
OP 7	0	0.0	0	0.0
OP 8	0	0.0	0	0.0
OP 9	0	0.0	0	0.0
OP 10	0	0.0	0	0.0
OP 11	0	0.0	0	0.0
OP 12	0	0.0	0	0.0
OP 13	0	0.0	0	0.0
OP 14	0	0.0	0	0.0
OP 15	0	0.0	0	0.0
OP 16	0	0.0	0	0.0
OP 17	0	0.0	0	0.0
OP 18	0	0.0	0	0.0
OP 19	0	0.0	0	0.0

**PV: PV11** no glare found

Receptor results ordered by category of glare

Receptor	Annual Green Glare		Annual Yellow Glare	
	min	hr	min	hr
Golden Highway	0	0.0	0	0.0
Sandy Creek Road - unsealed	0	0.0	0	0.0
Spring Ridge Road	0	0.0	0	0.0
OP 1	0	0.0	0	0.0
OP 2	0	0.0	0	0.0
OP 3	0	0.0	0	0.0
OP 4	0	0.0	0	0.0
OP 5	0	0.0	0	0.0
OP 6	0	0.0	0	0.0
OP 7	0	0.0	0	0.0
OP 8	0	0.0	0	0.0
OP 9	0	0.0	0	0.0
OP 10	0	0.0	0	0.0
OP 11	0	0.0	0	0.0
OP 12	0	0.0	0	0.0
OP 13	0	0.0	0	0.0
OP 14	0	0.0	0	0.0
OP 15	0	0.0	0	0.0
OP 16	0	0.0	0	0.0
OP 17	0	0.0	0	0.0
OP 18	0	0.0	0	0.0
OP 19	0	0.0	0	0.0

**PV11 and Route: Golden Highway**

No glare found

**PV11 and Route: Sandy Creek Road - unsealed**

No glare found

**PV11 and Route: Spring Ridge Road**

No glare found

**PV11 and OP 1**

No glare found

**PV11 and OP 2**

No glare found

**PV11 and OP 3**

No glare found

**PV11 and OP 4**

No glare found

**PV11 and OP 5**

No glare found

**PV11 and OP 6**

No glare found

**PV11 and OP 7**

No glare found

**PV11 and OP 8**

No glare found

**PV11 and OP 9**

No glare found

**PV11 and OP 10**

No glare found

**PV11 and OP 11**

No glare found

**PV11 and OP 12**

No glare found

**PV11 and OP 13**

No glare found

**PV11 and OP 14**

No glare found

**PV11 and OP 15**

No glare found

**PV11 and OP 16**

No glare found

**PV11 and OP 17**

No glare found

**PV11 and OP 18**

No glare found

**PV11 and OP 19**

No glare found

# Assumptions

---

"Green" glare is glare with low potential to cause an after-image (flash blindness) when observed prior to a typical blink response time.

"Yellow" glare is glare with potential to cause an after-image (flash blindness) when observed prior to a typical blink response time.

Times associated with glare are denoted in Standard time. For Daylight Savings, add one hour.

The algorithm does not rigorously represent the detailed geometry of a system; detailed features such as gaps between modules, variable height of the PV array, and support structures may impact actual glare results. However, we have validated our models against several systems, including a PV array causing glare to the air-traffic control tower at Manchester-Boston Regional Airport and several sites in Albuquerque, and the tool accurately predicted the occurrence and intensity of glare at different times and days of the year.

Several V1 calculations utilize the PV array centroid, rather than the actual glare spot location, due to algorithm limitations. This may affect results for large PV footprints. Additional analyses of array sub-sections can provide additional information on expected glare. This primarily affects V1 analyses of path receptors.

Random number computations are utilized by various steps of the annual hazard analysis algorithm. Predicted minutes of glare can vary between runs as a result. This limitation primarily affects analyses of Observation Point receptors, including ATCTs. Note that the SGHAT/ ForgeSolar methodology has always relied on an analytical, qualitative approach to accurately determine the overall hazard (i.e. green vs. yellow) of expected glare on an annual basis.

The analysis does not automatically consider obstacles (either man-made or natural) between the observation points and the prescribed solar installation that may obstruct observed glare, such as trees, hills, buildings, etc.

The subtended source angle (glare spot size) is constrained by the PV array footprint size. Partitioning large arrays into smaller sections will reduce the maximum potential subtended angle, potentially impacting results if actual glare spots are larger than the sub-array size. Additional analyses of the combined area of adjacent sub-arrays can provide more information on potential glare hazards. (See previous point on related limitations.)

The variable direct normal irradiance (DNI) feature (if selected) scales the user-prescribed peak DNI using a typical clear-day irradiance profile. This profile has a lower DNI in the mornings and evenings and a maximum at solar noon. The scaling uses a clear-day irradiance profile based on a normalized time relative to sunrise, solar noon, and sunset, which are prescribed by a sun-position algorithm and the latitude and longitude obtained from Google maps. The actual DNI on any given day can be affected by cloud cover, atmospheric attenuation, and other environmental factors.

The ocular hazard predicted by the tool depends on a number of environmental, optical, and human factors, which can be uncertain. We provide input fields and typical ranges of values for these factors so that the user can vary these parameters to see if they have an impact on the results. The speed of SGHAT allows expedited sensitivity and parametric analyses.

The system output calculation is a DNI-based approximation that assumes clear, sunny skies year-round. It should not be used in place of more rigorous modeling methods.

Hazard zone boundaries shown in the Glare Hazard plot are an approximation and visual aid based on aggregated research data. Actual ocular impact outcomes encompass a continuous, not discrete, spectrum.

Glare locations displayed on receptor plots are approximate. Actual glare-spot locations may differ.

Refer to the Help page at [www.forgesolar.com/help/](http://www.forgesolar.com/help/) for assumptions and limitations not listed here.

Default glare analysis parameters and observer eye characteristics (for reference only):

- Analysis time interval: 1 minute
- Ocular transmission coefficient: 0.5
- Pupil diameter: 0.002 meters
- Eye focal length: 0.017 meters
- Sun subtended angle: 9.3 milliradians

© Sims Industries d/b/a ForgeSolar, All Rights Reserved.



moir  
STUDIO

# COBBORA SOLAR FARM

Appendix D - Cumulative Wireframes

# Cobbora Solar Farm

## Cumulative Wireframes

### Prepared for

Pacific Partnerships Pty Limited

### Issue

C

### Date

28/05/2025

### Project Number

2490

Revision	Date	Author	Checked	Comment
A	22/01/2025	CD	NL	Cumulative Assessments
B	11/03/2025	CD	-	Cumulative Assessments
C	29/5/2025	CD	AR	Cumulative Assessments



Moir Landscape Architecture Pty Ltd  
(T/A Moir Studio)  
Studio 1, 88 Fern Street  
PO Box 111, Islington NSW 2296  
admin@moirla.com.au  
Ph.(02) 4965 3500  
www.moirstudio.com.au  
ACN: 097 558 908  
ABN: 48 097 558 908

# Contents

<b>1</b>	<b>Cumulative Assessment (Wireframes)</b>	<b>4</b>
	PR_1	4
	PR_5a (East)	6
	PR_5b (West)	8
	PR_9	10
	PR_10	12
	PR_15	14
	PR_16	16
	PR_21	18
	PR_22	20
	PR_24	22
	PR_30	24
	X07	26
	X09	28

Dwelling/Public Viewpoint ID:

**PR\_1**

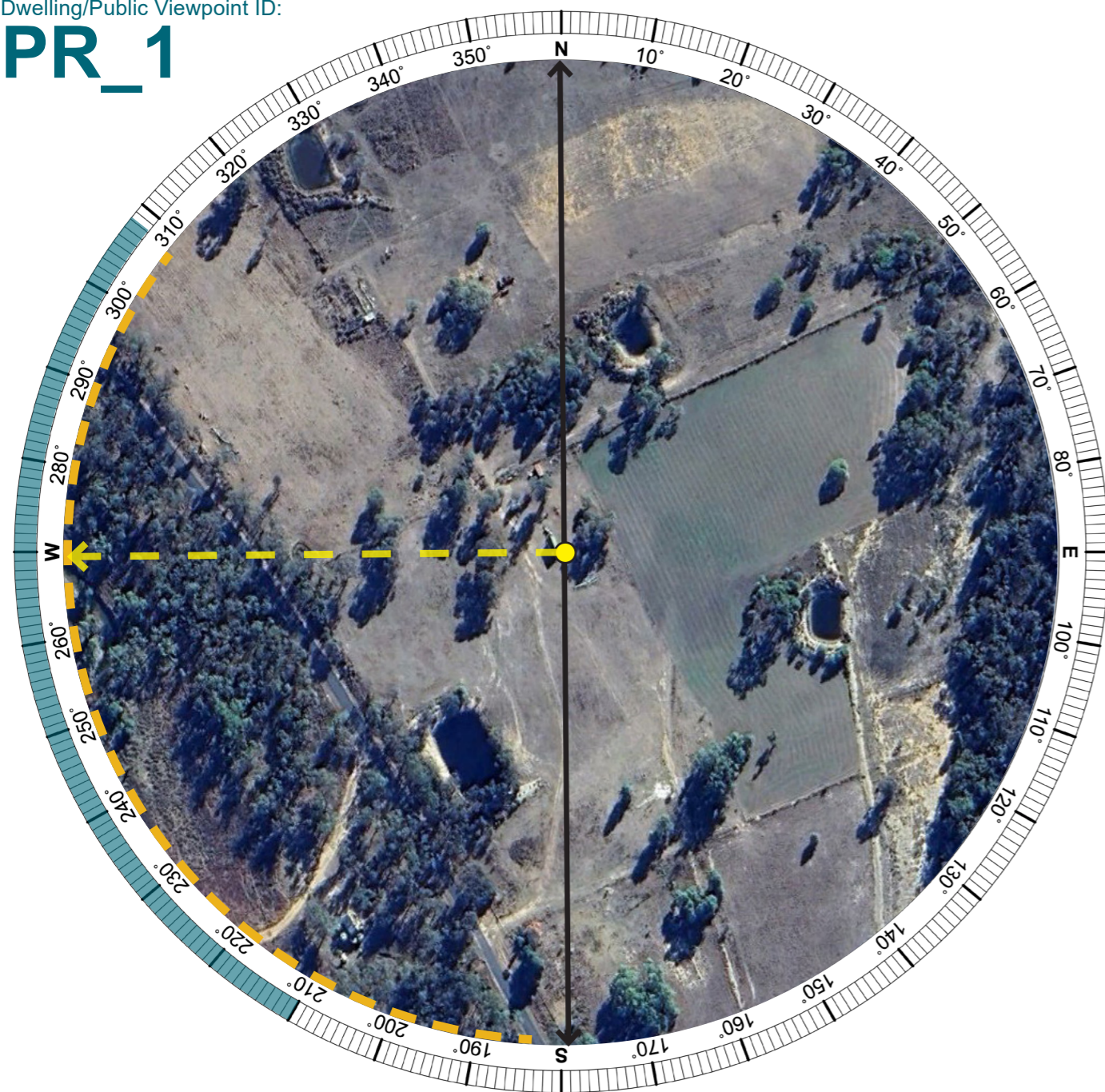

**LEGEND**

- The Project Extent - Potential visibility of the Project (Cobbora Solar Farm) (based on topography alone)
- Cumulative Extent - Potential visibility of surrounding projects (DSF/SCSF/The Project) (based on topography alone)
- Direction of the Wireframe
- Extent of Panorama
- Location of the viewpoint

Aerial Image - Wireframe Location (Aerial Image Source: Google Earth 2023)

**Residential Receptor PR\_1**

Receptor Assessment:								
Coordinates	Distance to development:	Viewpoint Type:	Receptor Sensitivity:	Scenic Quality:	Overall Sensitivity:	Total Occupied Cells:	Magnitude Rating:	Preliminary Visual Impact Rating:
32°10'41.57"S 149°15'42.95"E	0.26 km	Residential Receptor	Moderate	Low	Moderate	19	Moderate	Moderate

OCCUPIED CELL COUNT (SOLAR FARM)		Cobbora Solar Farm (The Project)	Sandy Creek Solar Farm	Dapper Solar Farm
<div style="display: flex; align-items: center;"> <div style="width: 15px; height: 10px; background-color: #c0392b; margin-right: 5px;"></div> <span>Occupied Cell (greater than 25%)</span> </div> <small>A cell is unoccupied if elements of the project, including solar panels, battery energy systems, or other associated infrastructure do not occupy more than approximately 25% of a cell.</small>	<b>Occupied Cells Per Project</b>	16	3	0

PR\_1  
Residential Receptor

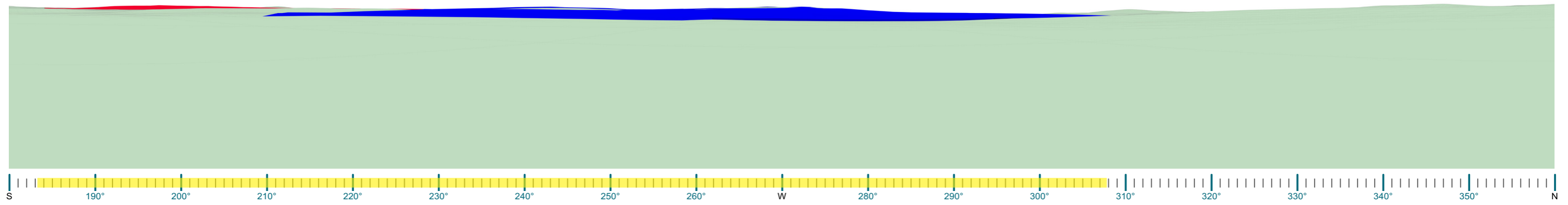

Cumulative Extent - Potential visibility of surrounding projects (based on topography alone)

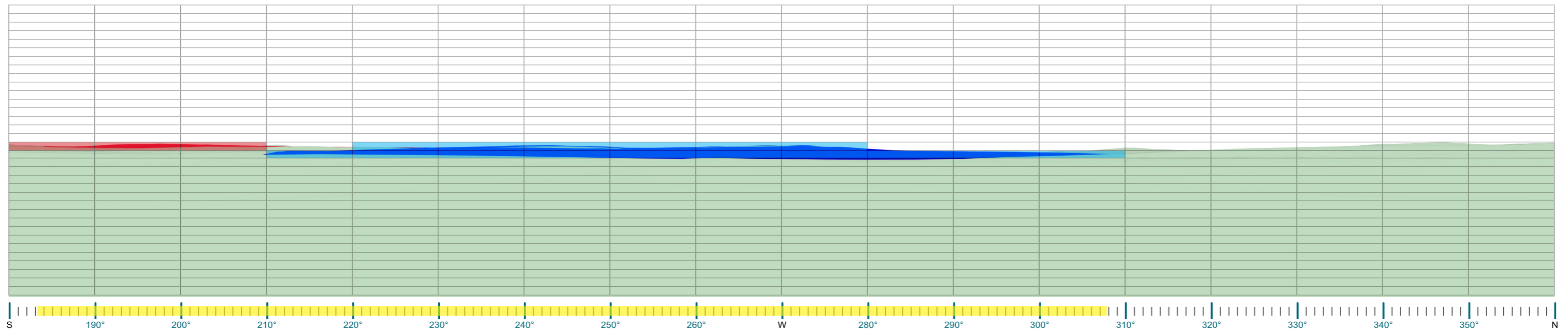
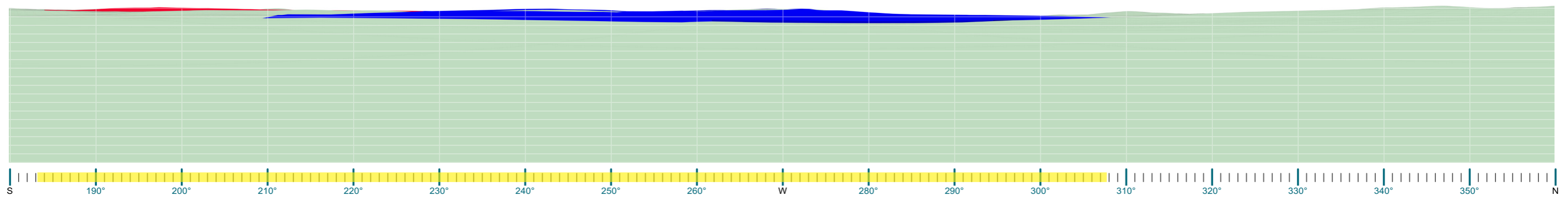



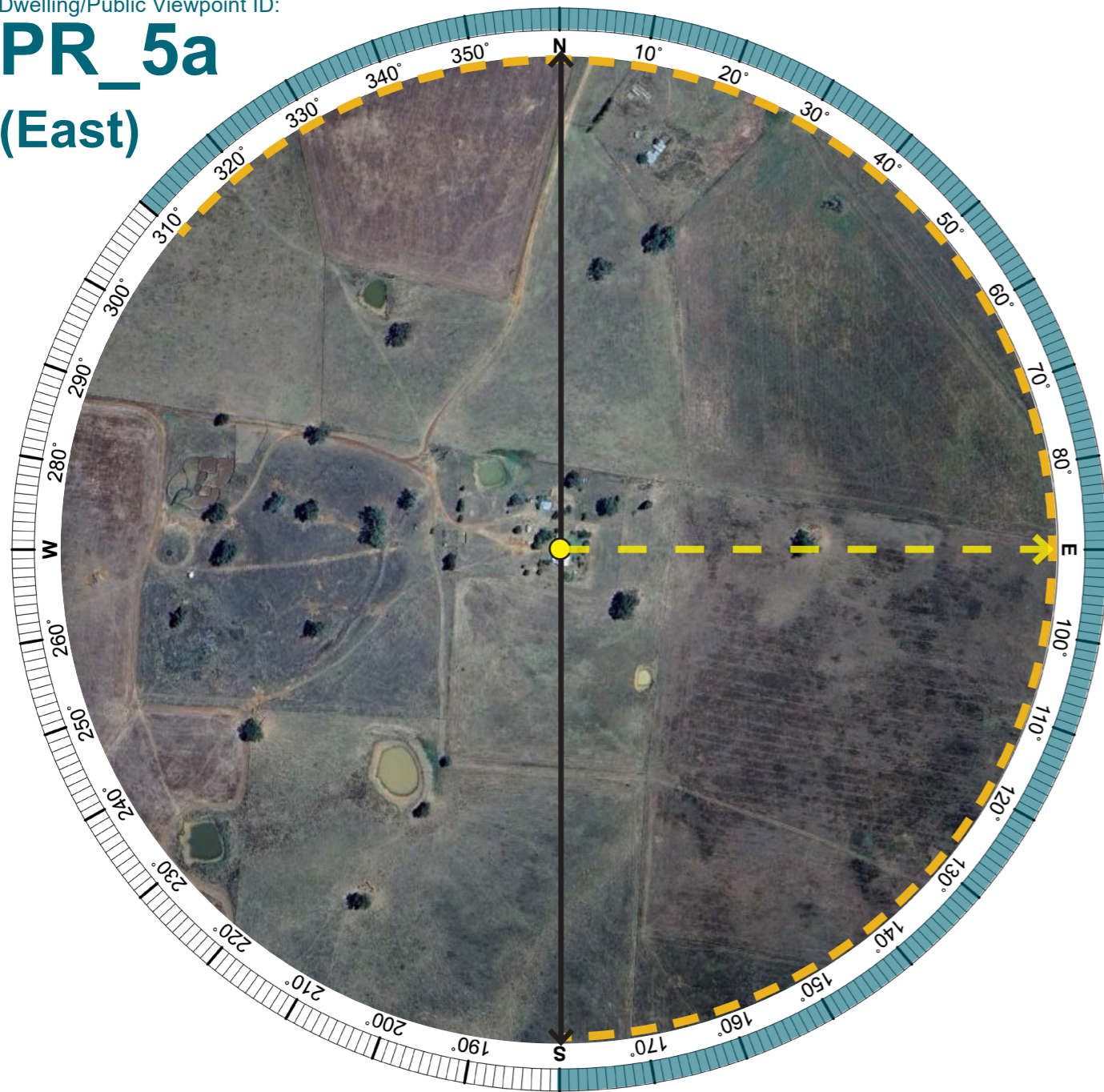

Dwelling/Public Viewpoint ID:

# PR\_5a (East)



### LEGEND

-  The Project Extent - Potential visibility of the Project (Cobbora Solar Farm) (based on topography alone)
-  Cumulative Extent - Potential visibility of surrounding projects (DSF/SCSF/The Project) (based on topography alone)
-  Direction of the Wireframe
-  Extent of Panorama
-  Location of the viewpoint

Aerial Image - Wireframe Location (Aerial Image Source: Google Earth 2023)

PR\_5a (East)  
Residential Receptor

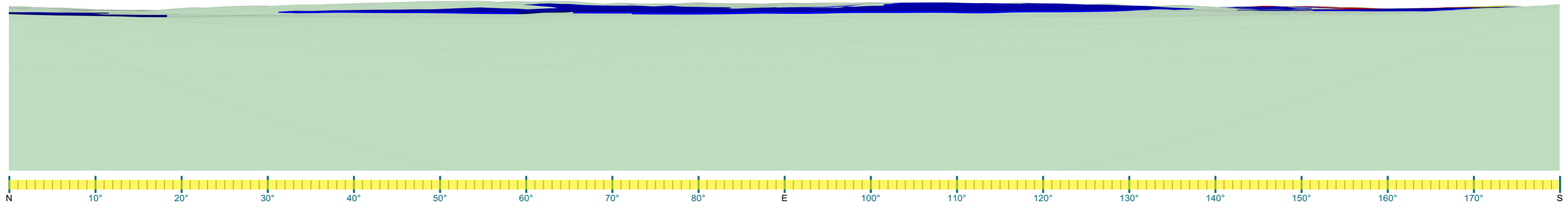

Cumulative Extent - Potential visibility of surrounding projects (based on topography alone)

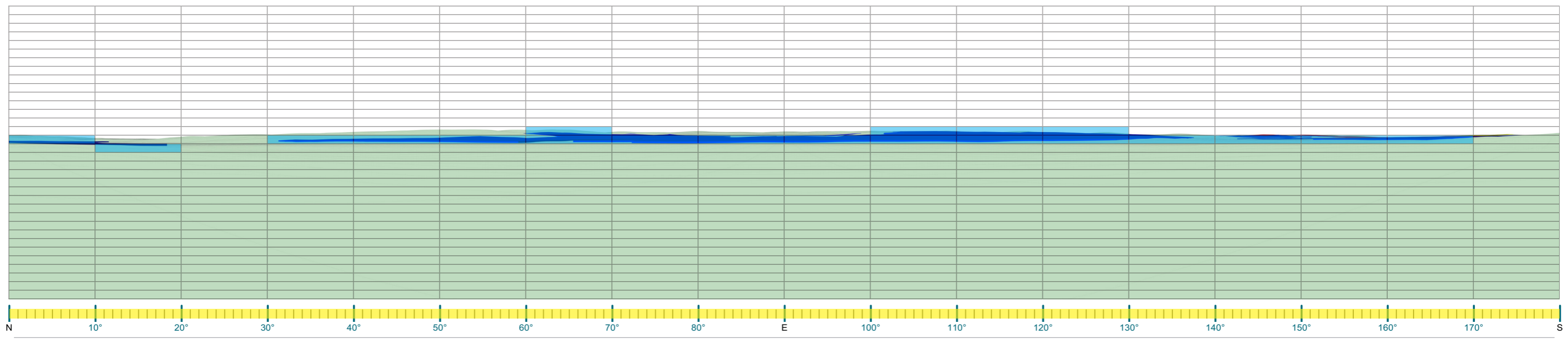
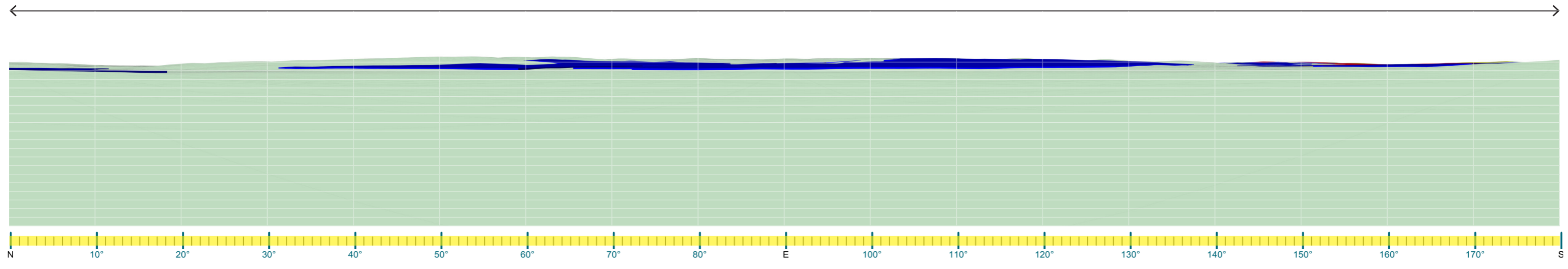

Dwelling/Public Viewpoint ID:

# PR\_5b (West)

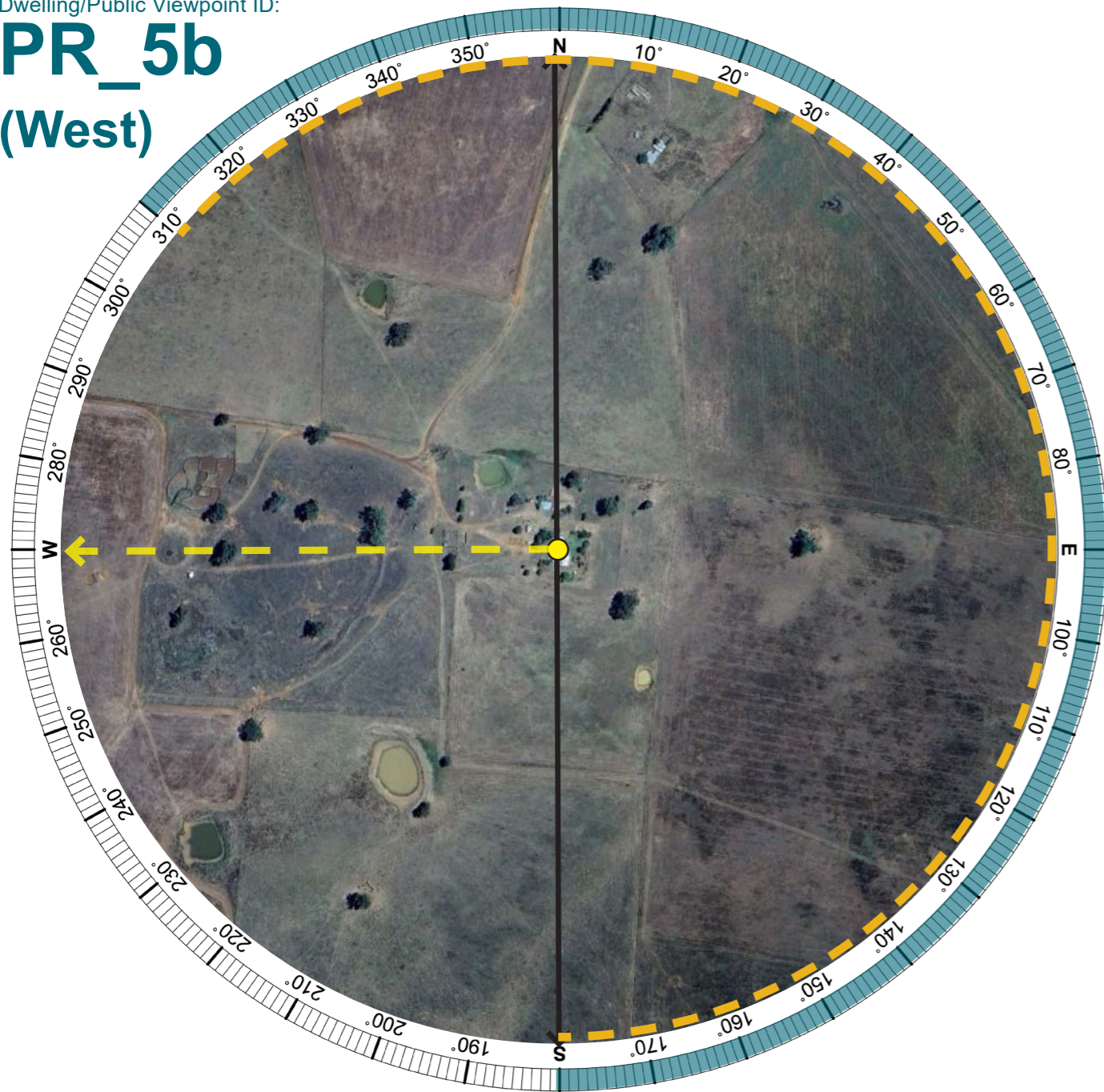

### LEGEND

- The Project Extent - Potential visibility of the Project (Cobbora Solar Farm) (based on topography alone)
- Cumulative Extent - Potential visibility of surrounding projects (DSF/SCSF/The Project) (based on topography alone)
- Direction of the Wireframe
- ↔ Extent of Panorama
- Location of the viewpoint

Aerial Image - Wireframe Location (Aerial Image Source: Google Earth 2023)

## Residential Receptor PR\_5 (East & West)

Receptor Assessment:								
Coordinates	Distance to development:	Viewpoint Type:	Receptor Sensitivity:	Scenic Quality:	Overall Sensitivity:	Total Occupied Cells:	Magnitude Rating:	Preliminary Visual Impact Rating:
32° 7'52.52"S 149° 11'33.84"E	0.75 km	Residential Receptor	Moderate	Low	Moderate	23	Moderate	Moderate

OCCUPIED CELL COUNT (SOLAR FARM)	Cobbora Solar Farm (The Project)	Sandy Creek Solar Farm	Dapper Solar Farm
<span style="display: inline-block; width: 15px; height: 10px; background-color: #d2691e; border: 1px solid black; margin-right: 5px;"></span> Occupied Cell (greater than 25%) A cell is unoccupied if elements of the project, including solar panels, battery energy systems, or other associated infrastructure do not occupy more than approximately 25% of a cell.	<b>Occupied Cells Per Project</b>	23	0

PR\_5b (West)  
Residential Receptor

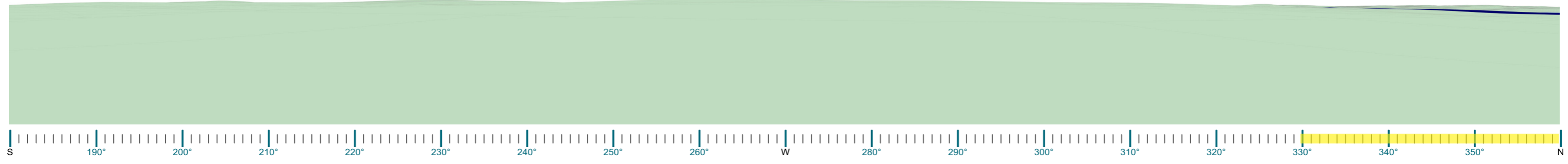

Cumulative Extent - Potential visibility of surrounding projects  
(based on topography alone)

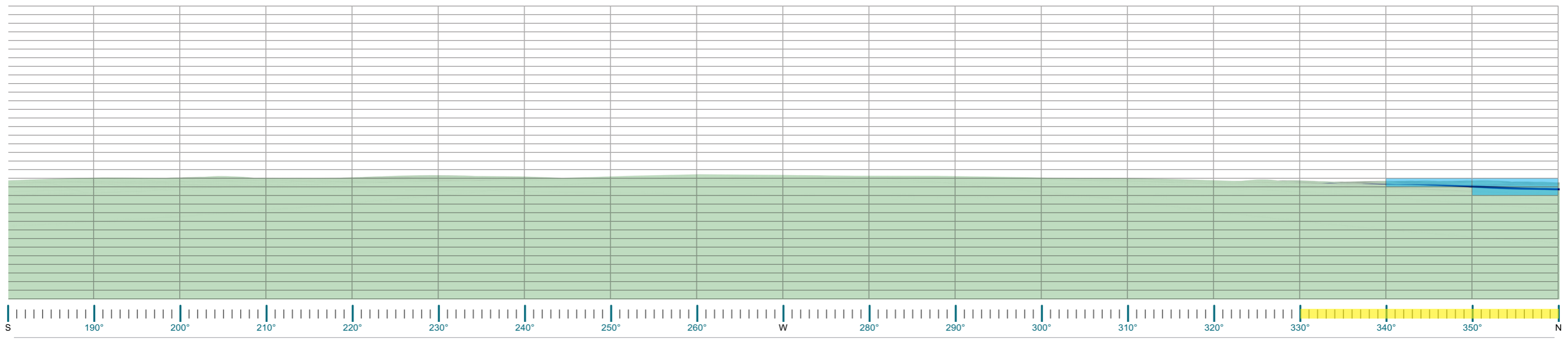
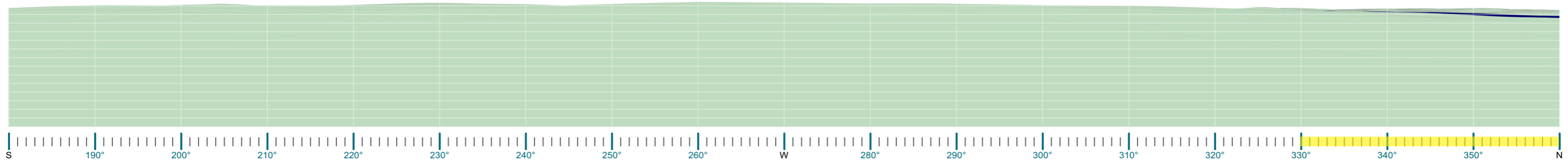

Dwelling/Public Viewpoint ID:

**PR\_9**

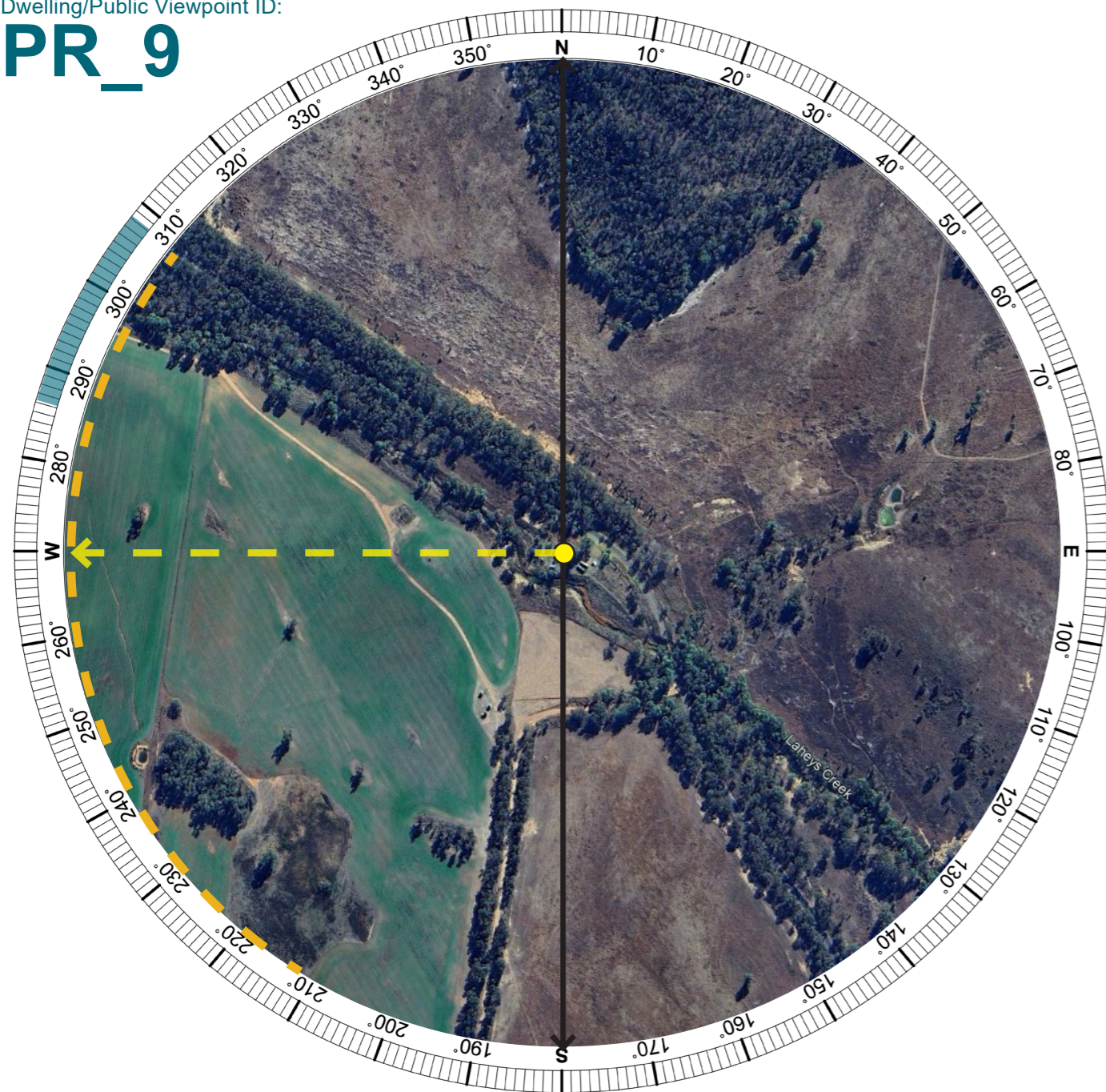

**LEGEND**

- The Project Extent - Potential visibility of the Project (Cobbora Solar Farm) (based on topography alone)
- Cumulative Extent - Potential visibility of surrounding projects (DSF/SCSF/The Project) (based on topography alone)
- Direction of the Wireframe
- ↔ Extent of Panorama
- Location of the viewpoint

Aerial Image - Wireframe Location (Aerial Image Source: Google Earth 2023)

**Residential Receptor PR\_9**

Receptor Assessment:								
Coordinates	Distance to development:	Viewpoint Type:	Receptor Sensitivity:	Scenic Quality:	Overall Sensitivity:	Total Occupied Cells:	Magnitude Rating:	Preliminary Visual Impact Rating:
32°11'22.68"S 149°16'16.84"E	0.39 km	Residential Receptor	Moderate	Low	Moderate	5	Very Low	Low

OCCUPIED CELL COUNT (SOLAR FARM)		Cobbora Solar Farm (The Project)	Sandy Creek Solar Farm	Dapper Solar Farm
<span style="display: inline-block; width: 15px; height: 10px; background-color: #c08080; border: 1px solid black; margin-right: 5px;"></span> Occupied Cell (greater than 25%) A cell is unoccupied if elements of the project, including solar panels, battery energy systems, or other associated infrastructure do not occupy more than approximately 25% of a cell.	<b>Occupied Cells Per Project</b>	3	2	0

PR\_9  
Residential Receptor

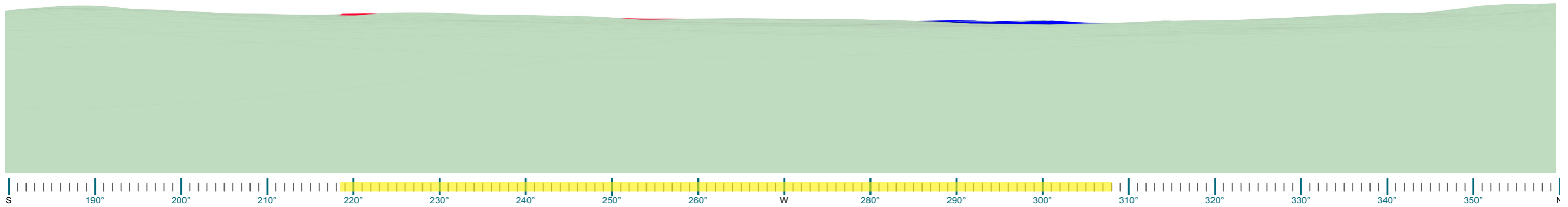

Cumulative Extent - Potential visibility of surrounding projects (based on topography alone)

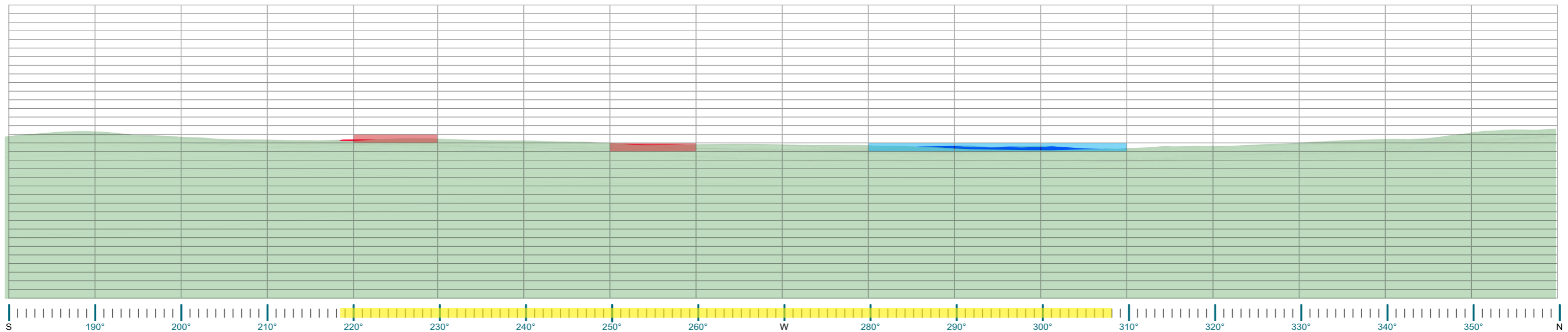
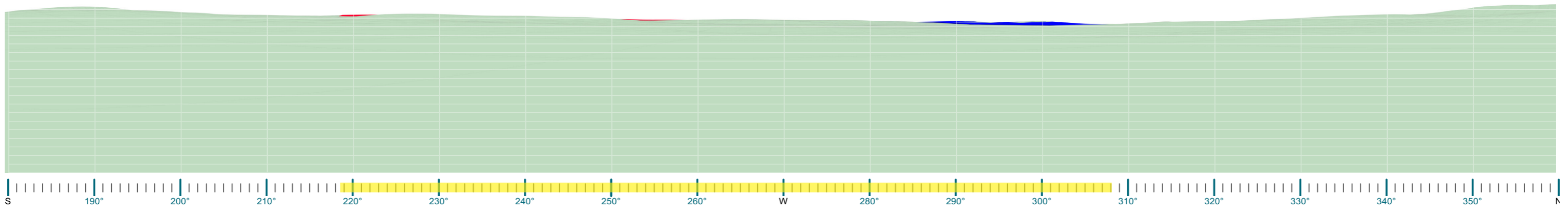

Dwelling/Public Viewpoint ID:

**PR\_10**

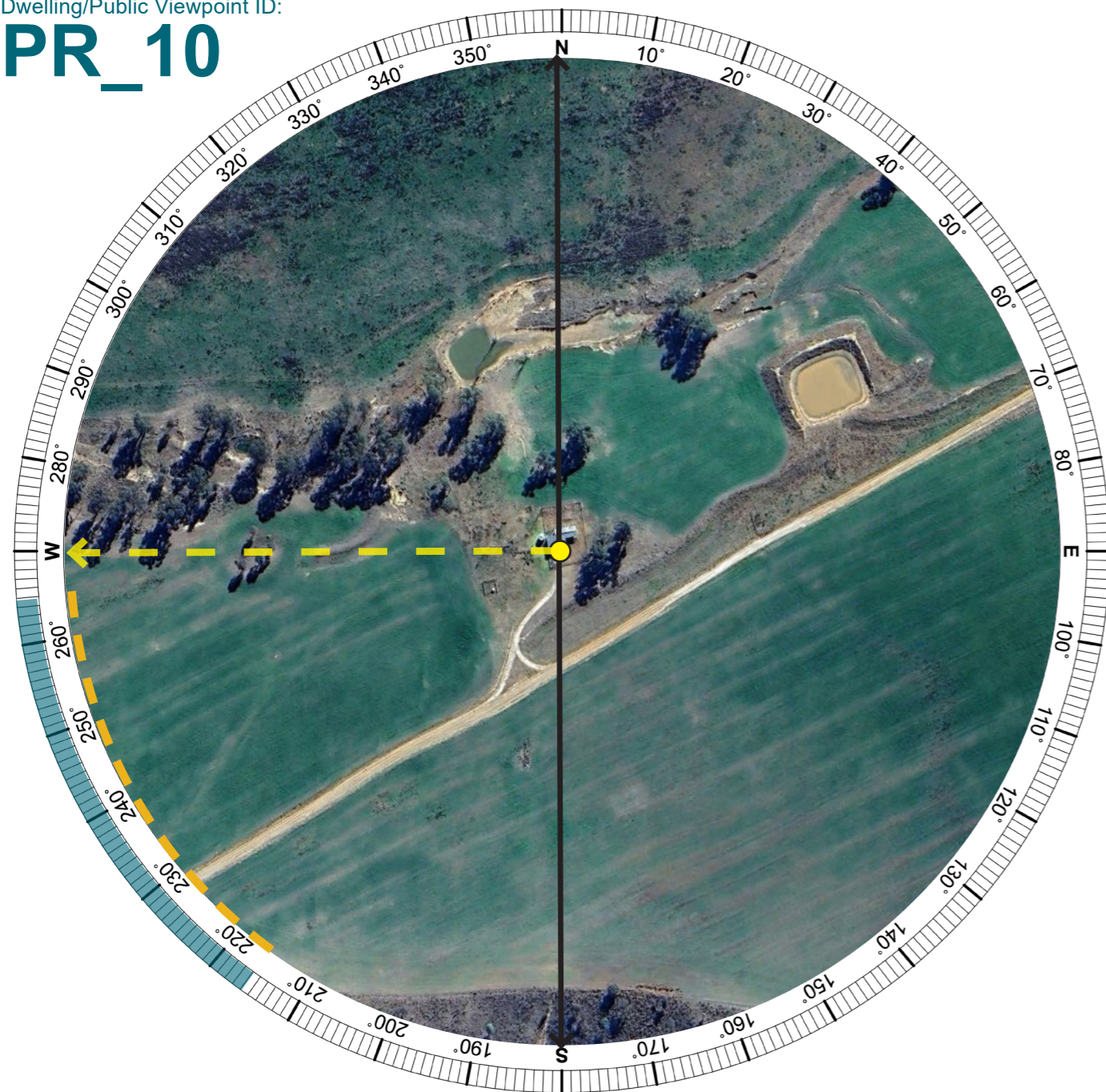

**LEGEND**

- The Project Extent - Potential visibility of the Project (Cobbora Solar Farm) (based on topography alone)
- Cumulative Extent - Potential visibility of surrounding projects (DSF/SCSF/The Project) (based on topography alone)
- Direction of the Wireframe
- ↔ Extent of Panorama
- Location of the viewpoint

Aerial Image - Wireframe Location (Aerial Image Source: Google Earth 2023)

**Residential Receptor PR\_10**

Receptor Assessment:								
Coordinates	Distance to development:	Viewpoint Type:	Receptor Sensitivity:	Scenic Quality:	Overall Sensitivity:	Total Occupied Cells:	Magnitude Rating:	Preliminary Visual Impact Rating:
32° 9'45.66"S 149° 15'43.52"E	1.28 km	Residential Receptor	Moderate	Low	Moderate	5	Very Low	Low

		Cobbora Solar Farm (The Project)	Sandy Creek Solar Farm	Dapper Solar Farm
<p><b>OCCUPIED CELL COUNT (SOLAR FARM)</b></p> <p><span style="display: inline-block; width: 15px; height: 10px; background-color: #C0392B; border: 1px solid black; margin-right: 5px;"></span> Occupied Cell (greater than 25%)</p> <p><small>A cell is unoccupied if elements of the project, including solar panels, battery energy systems, or other associated infrastructure do not occupy more than approximately 25% of a cell.</small></p>	<b>Occupied Cells Per Project</b>	5	0	NA (Dwelling located outside study area)

PR\_10  
Residential Receptor

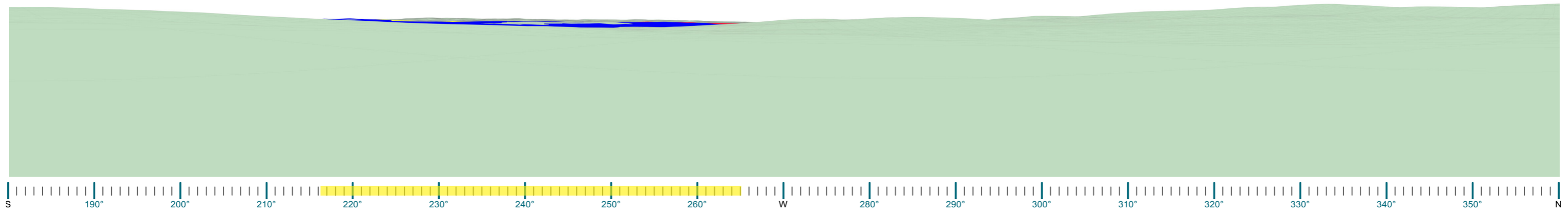

Cumulative Extent - Potential visibility of surrounding projects  
(based on topography alone)

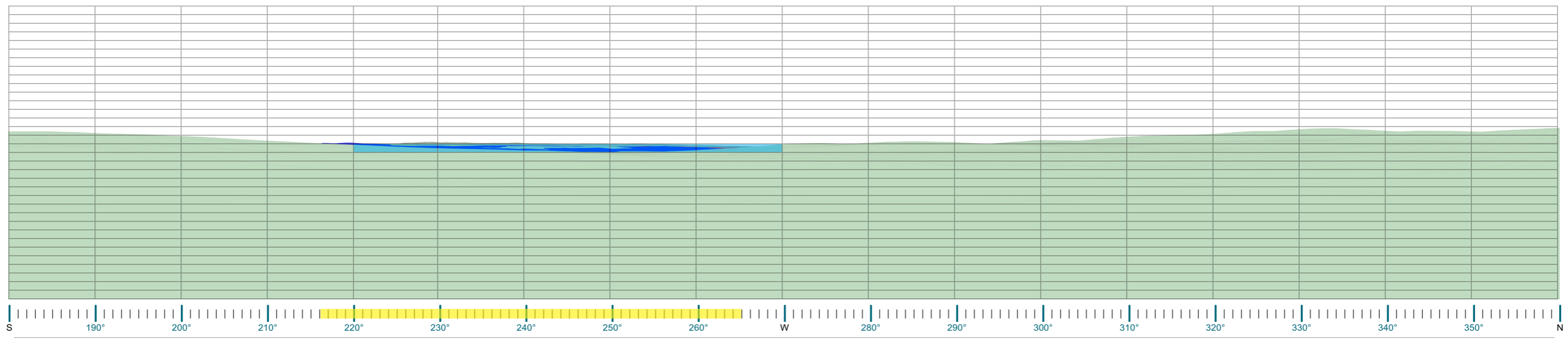
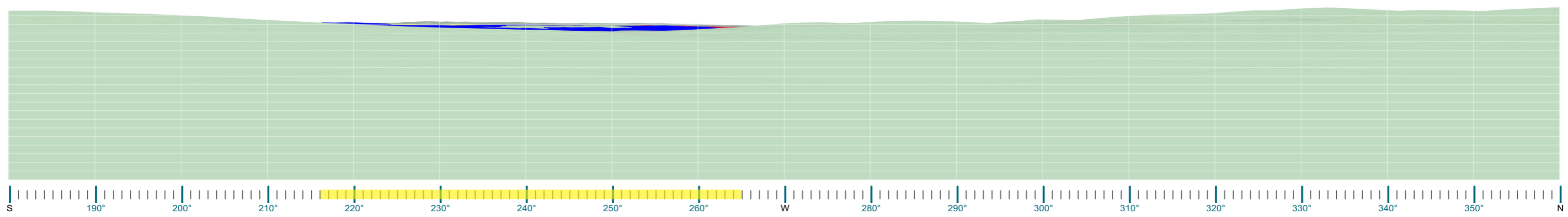

Dwelling/Public Viewpoint ID:

**PR\_15**

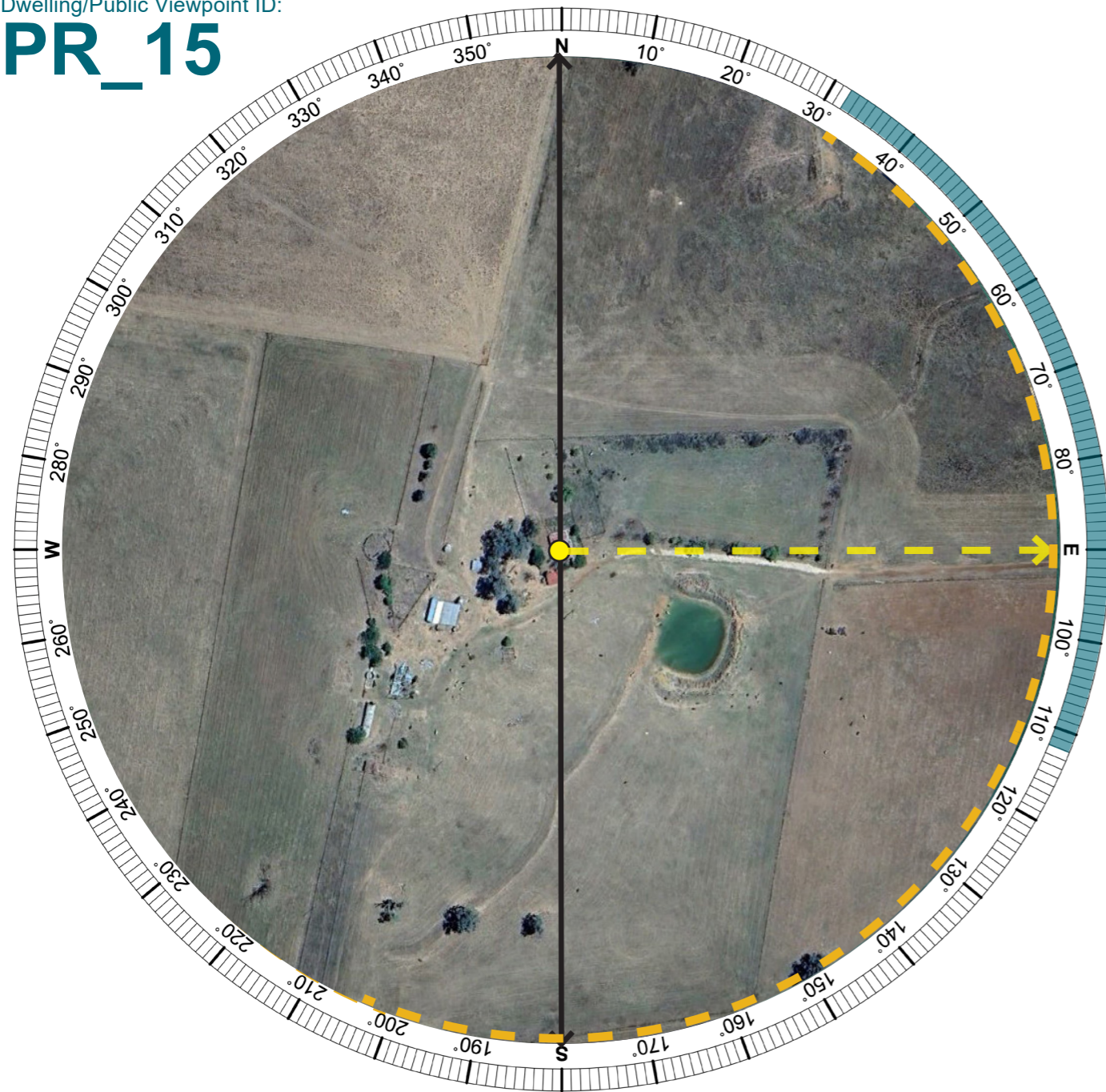

**LEGEND**

- The Project Extent - Potential visibility of the Project (Cobbora Solar Farm) (based on topography alone)
- Cumulative Extent - Potential visibility of surrounding projects (DSF/SCSF/The Project) (based on topography alone)
- Direction of the Wireframe
- Extent of Panorama
- Location of the viewpoint

Aerial Image - Wireframe Location (Aerial Image Source: Google Earth 2023)

**Residential Receptor PR\_15**

Receptor Assessment:								
Coordinates	Distance to development:	Viewpoint Type:	Receptor Sensitivity:	Scenic Quality:	Overall Sensitivity:	Total Occupied Cells:	Magnitude Rating:	Preliminary Visual Impact Rating:
32°10'0.77"S 149°10'41.50"E	0.80 km	Residential Receptor	Moderate	Low	Moderate	21	High	Moderate

OCCUPIED CELL COUNT (SOLAR FARM)		Cobbora Solar Farm (The Project)	Sandy Creek Solar Farm	Dapper Solar Farm
<span style="display: inline-block; width: 15px; height: 10px; background-color: #8B4513; border: 1px solid black; margin-right: 5px;"></span> Occupied Cell (greater than 25%) <small>A cell is unoccupied if elements of the project, including solar panels, battery energy systems, or other associated infrastructure do not occupy more than approximately 25% of a cell.</small>	<b>Occupied Cells Per Project</b>	5	12	4

PR\_15  
Residential Receptor

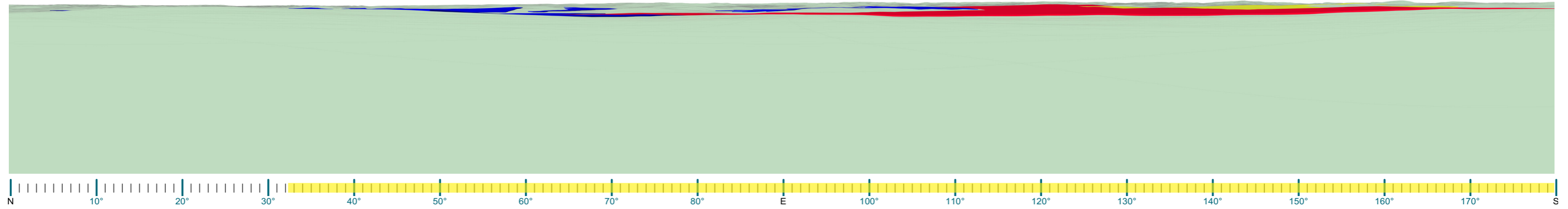

Cumulative Extent - Potential visibility of surrounding projects (based on topography alone)

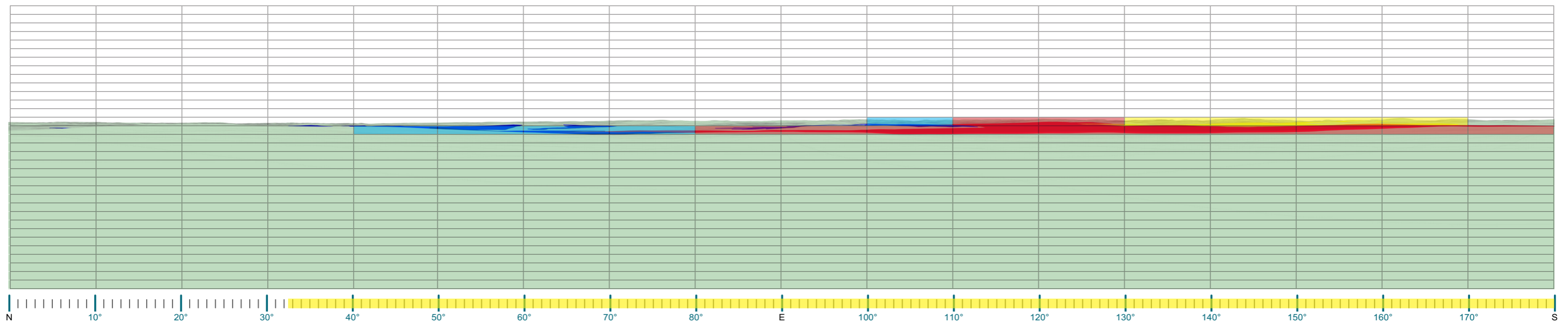
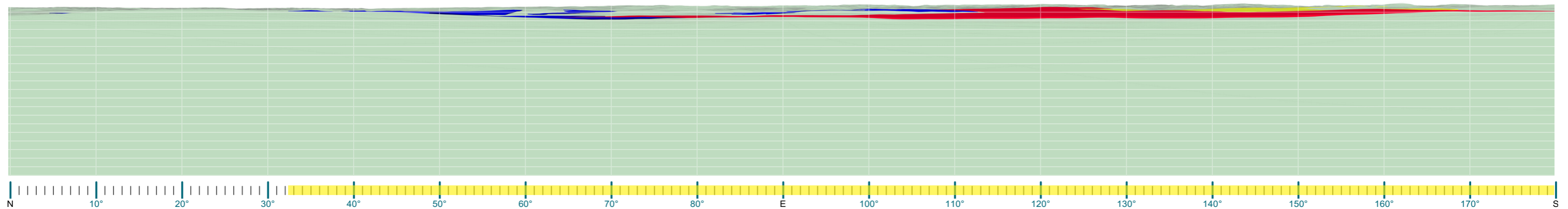

Dwelling/Public Viewpoint ID:

**PR\_16**

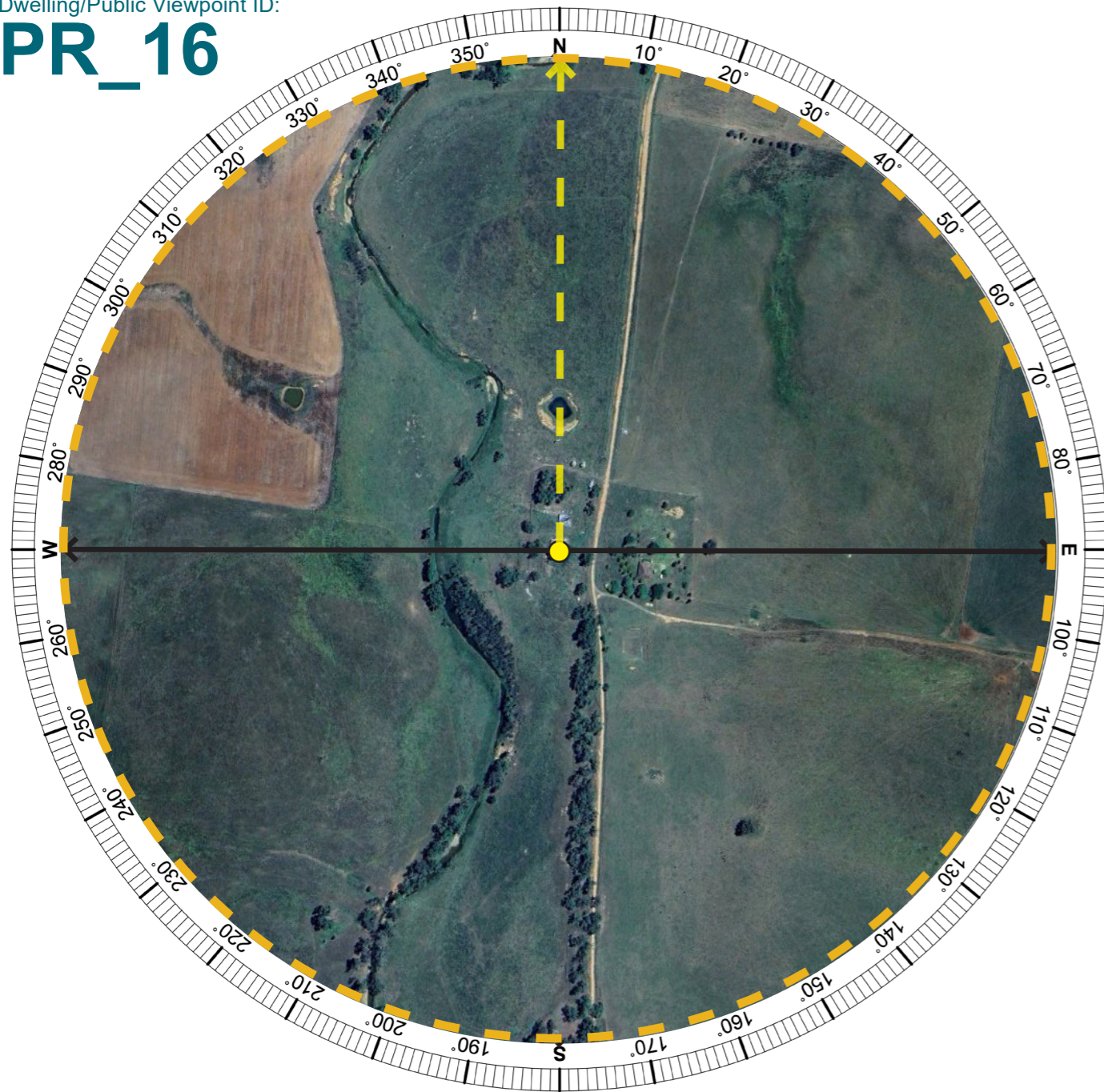

**NOTE:**  
The dwelling is located within the project boundary of Sandy Creek Solar Farm, and the wireframe is mass modelled to the worst case scenario (to the project boundary). Consequently, the wireframe indicates that the entire view will be occupied by Sandy Creek Solar Farm.

**LEGEND**

- The Project Extent - Potential visibility of the Project (Cobbora Solar Farm) (based on topography alone)
- Cumulative Extent - Potential visibility of surrounding projects (DSF/SCSF/The Project) (based on topography alone)
- Direction of the Wireframe
- ↔ Extent of Panorama
- Location of the viewpoint

Aerial Image - Wireframe Location (Aerial Image Source: Google Earth 2023)

**Residential Receptor PR\_16**

Receptor Assessment:								
Coordinates	Distance to development:	Viewpoint Type:	Receptor Sensitivity:	Scenic Quality:	Overall Sensitivity:	Total Occupied Cells:	Magnitude Rating:	Preliminary Visual Impact Rating:
32°11'34.80"S 149°13'6.26"E	1.16 km	Residential Receptor	Moderate	Low	Moderate	NA	NA	NA

OCCUPIED CELL COUNT (SOLAR FARM)		Cobbora Solar Farm (The Project)	Sandy Creek Solar Farm	Dapper Solar Farm
<span style="display: inline-block; width: 15px; height: 10px; background-color: #C00000; border: 1px solid black; margin-right: 5px;"></span> Occupied Cell (greater than 25%) A cell is unoccupied if elements of the project, including solar panels, battery energy systems, or other associated infrastructure do not occupy more than approximately 25% of a cell.	<b>Occupied Cells Per Project</b>	0	NA	0

PR\_16  
Residential Receptor

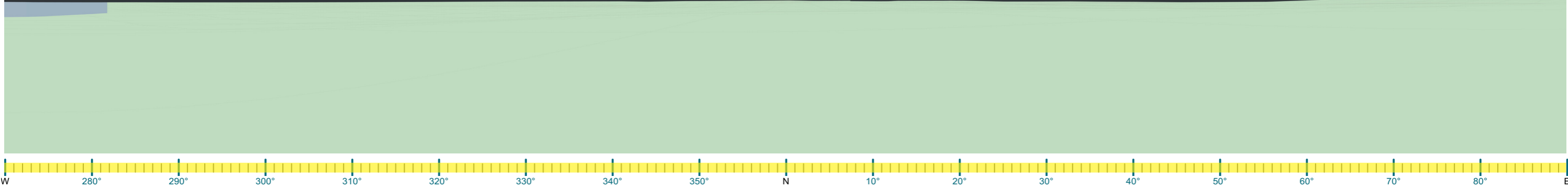

The dwelling is located within the project boundary of Sandy Creek Solar Farm, and the wireframe is mass modelled to the worst case scenario (to the project boundary). Consequently, the wireframe indicates that the entire view will be occupied by Sandy Creek Solar Farm.

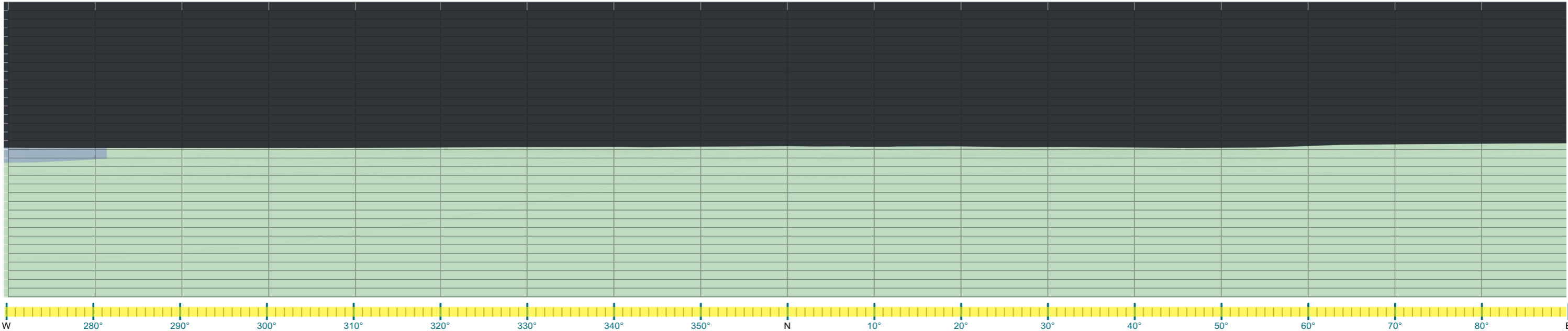
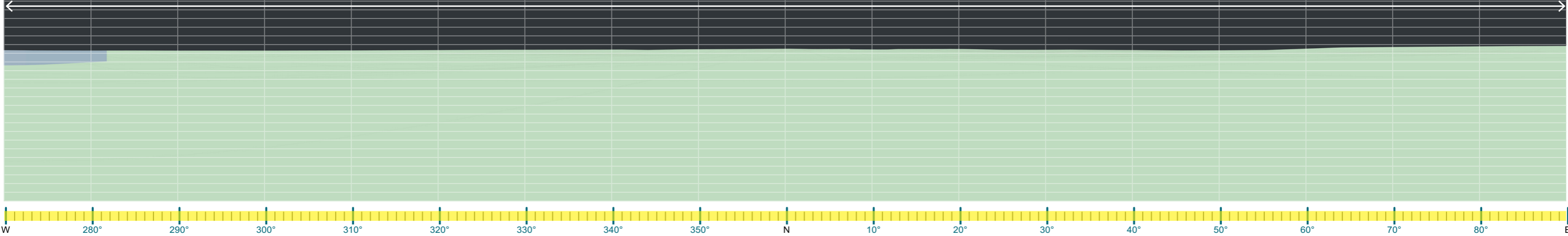

Dwelling/Public Viewpoint ID:

**PR\_21**

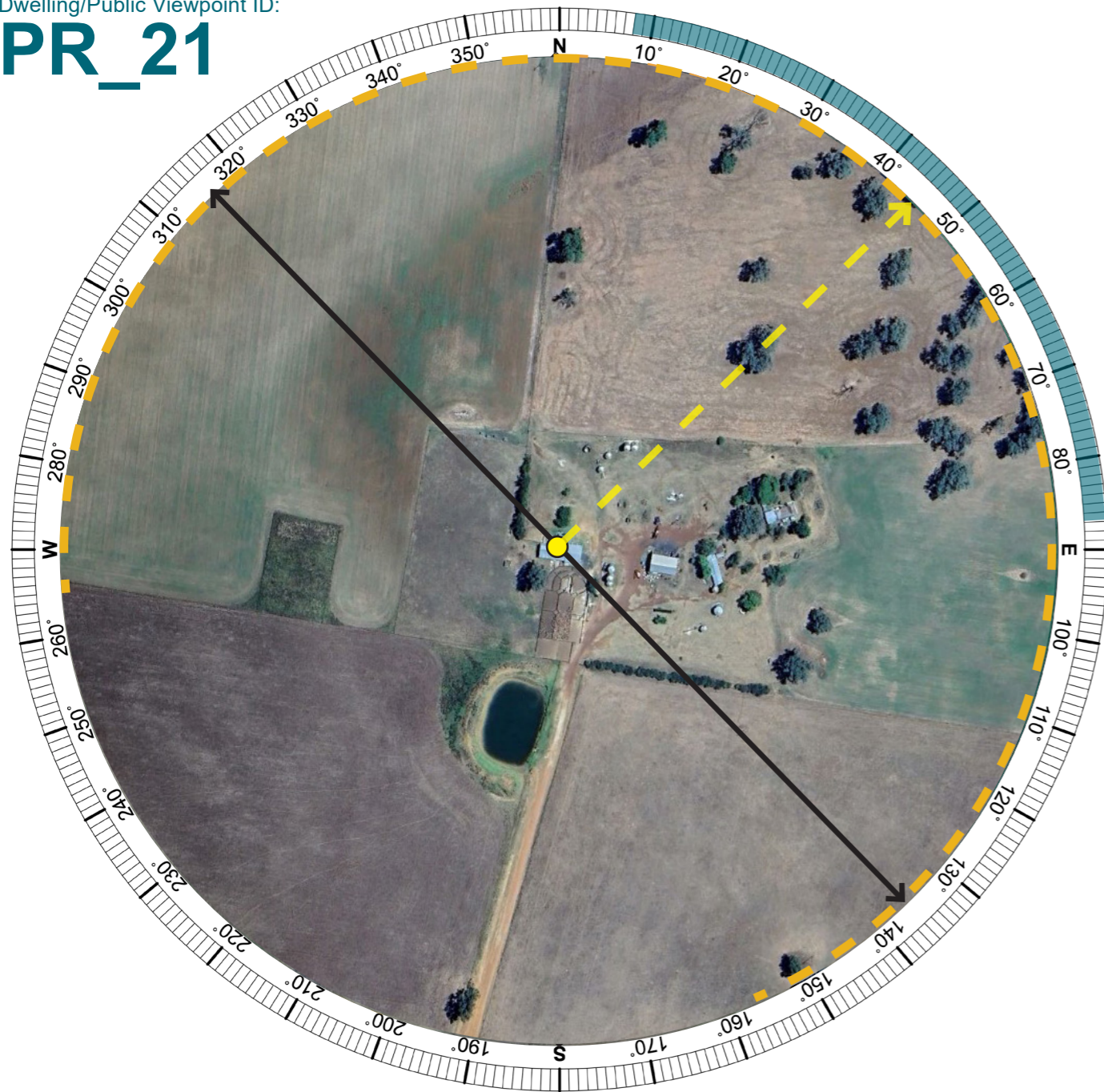

**LEGEND**

- The Project Extent - Potential visibility of the Project (Cobbora Solar Farm) (based on topography alone)
- Cumulative Extent - Potential visibility of surrounding projects (DSF/SCSF/The Project) (based on topography alone)
- Direction of the Wireframe
- ↔ Extent of Panorama
- Location of the viewpoint

Aerial Image - Wireframe Location (Aerial Image Source: Google Earth 2023)

**Residential Receptor PR\_21**

**Receptor Assessment:**

Coordinates	Distance to development:	Viewpoint Type:	Receptor Sensitivity:	Scenic Quality:	Overall Sensitivity:	Total Occupied Cells:	Magnitude Rating:	Preliminary Visual Impact Rating:
32°11'12.53"S 149°10'51.11"E	2.78 km	Residential Receptor	Moderate	Low	Moderate	26	High	Moderate

**OCCUPIED CELL COUNT (SOLAR FARM)**

Occupied Cell (greater than 25%)

A cell is unoccupied if elements of the project, including solar panels, battery energy systems, or other associated infrastructure do not occupy more than approximately 25% of a cell.

	Cobbora Solar Farm (The Project)	Sandy Creek Solar Farm	Dapper Solar Farm
<b>Occupied Cells Per Project</b>	0	25	4

PR\_21  
Residential Receptor

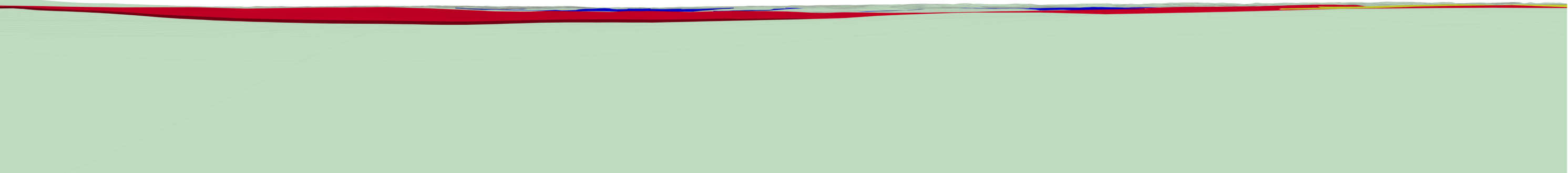

Cumulative Extent - Potential visibility of surrounding projects (based on topography alone)

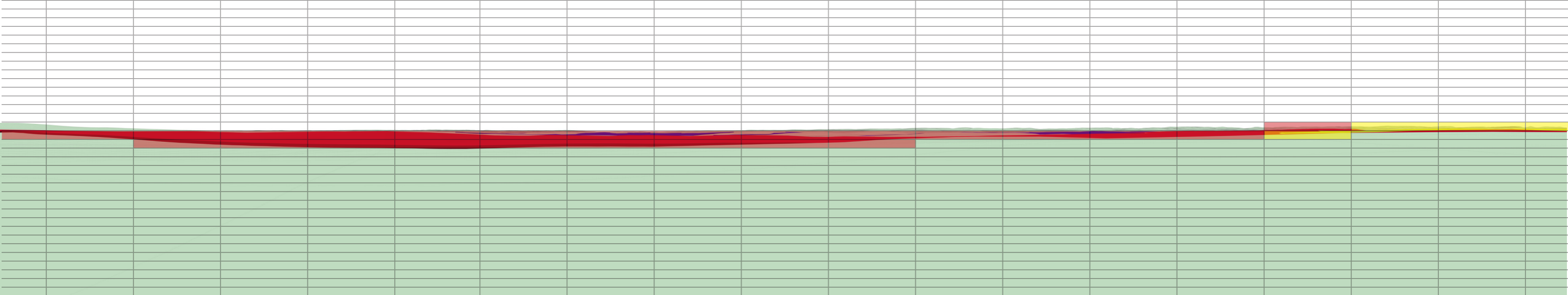
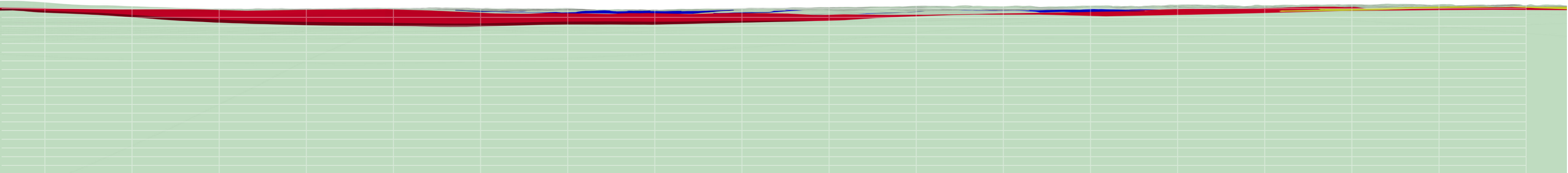

Dwelling/Public Viewpoint ID:

**PR\_22**

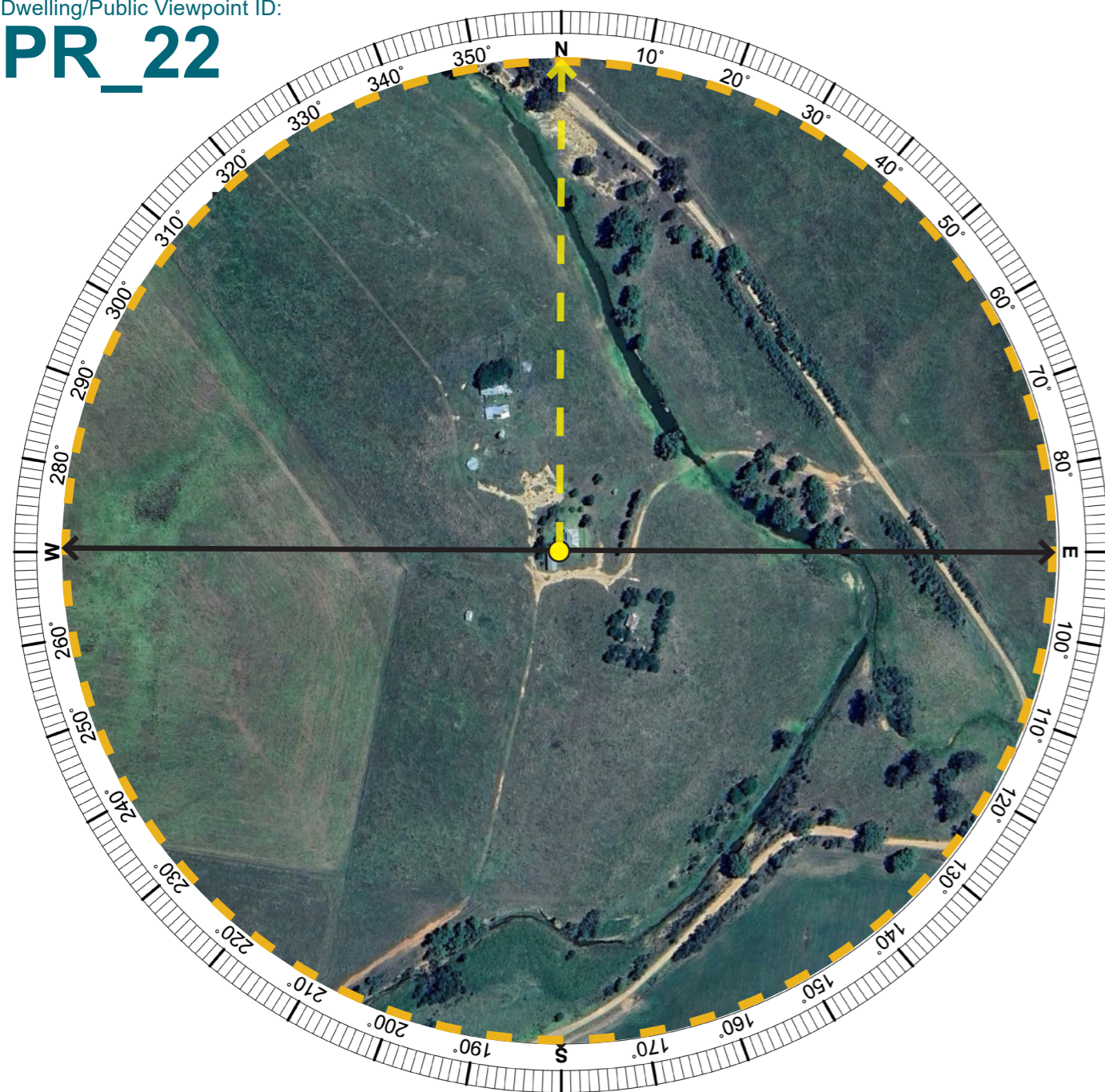

**NOTE:**  
The dwelling is located within the project boundary of Dapper Solar Farm, and the wireframe is mass modelled to the worst case scenario (to the project boundary). Consequently, the wireframe indicates that the entire view will be occupied by Dapper Solar Farm.

**LEGEND**

- The Project Extent - Potential visibility of the Project (Cobbora Solar Farm) (based on topography alone)
- Cumulative Extent - Potential visibility of surrounding projects (DSF/SCSF/The Project) (based on topography alone)
- Direction of the Wireframe
- Extent of Panorama
- Location of the viewpoint

Aerial Image - Wireframe Location (Aerial Image Source: Google Earth 2023)

**Residential Receptor PR\_22**

Receptor Assessment:								
Coordinates	Distance to development:	Viewpoint Type:	Receptor Sensitivity:	Scenic Quality:	Overall Sensitivity:	Total Occupied Cells:	Magnitude Rating:	Preliminary Visual Impact Rating:
32°12'11.27"S 149°13'12.85"E	2.18 km	Residential Receptor	Moderate	Low	Moderate	NA	NA	NA

OCCUPIED CELL COUNT (SOLAR FARM)		Cobbora Solar Farm (The Project)	Sandy Creek Solar Farm	Dapper Solar Farm
<span style="display: inline-block; width: 15px; height: 10px; background-color: #C00000; border: 1px solid black; margin-right: 5px;"></span> Occupied Cell (greater than 25%) A cell is unoccupied if elements of the project, including solar panels, battery energy systems, or other associated infrastructure do not occupy more than approximately 25% of a cell.	<b>Occupied Cells Per Project</b>	0	0	

PR\_22  
Residential Receptor

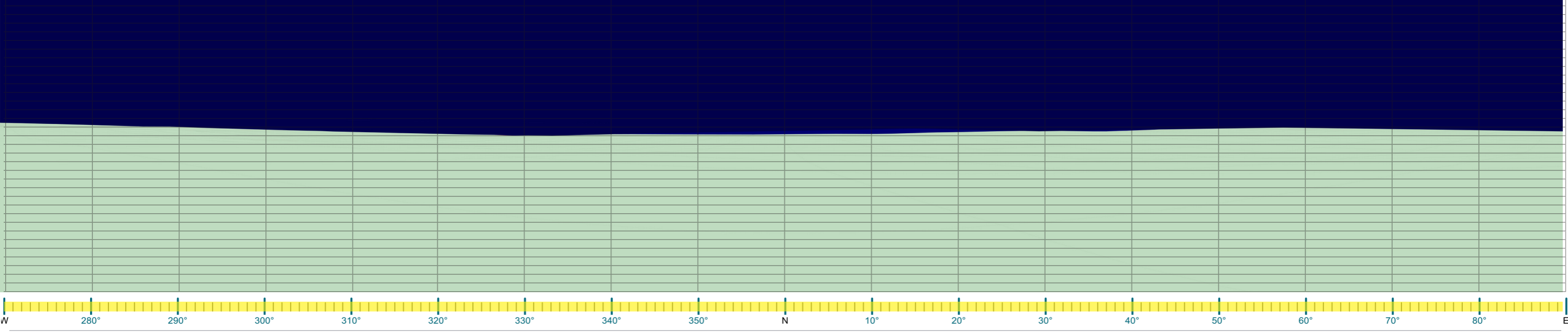
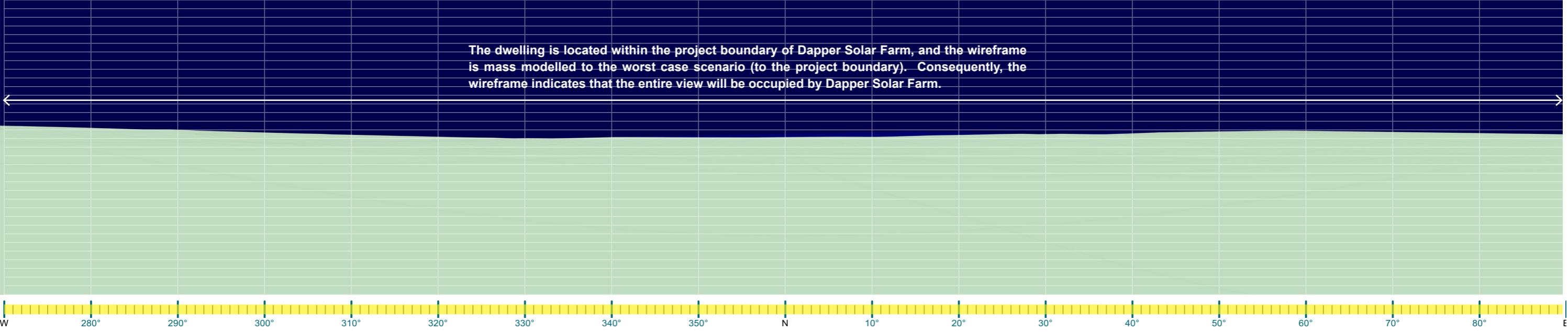
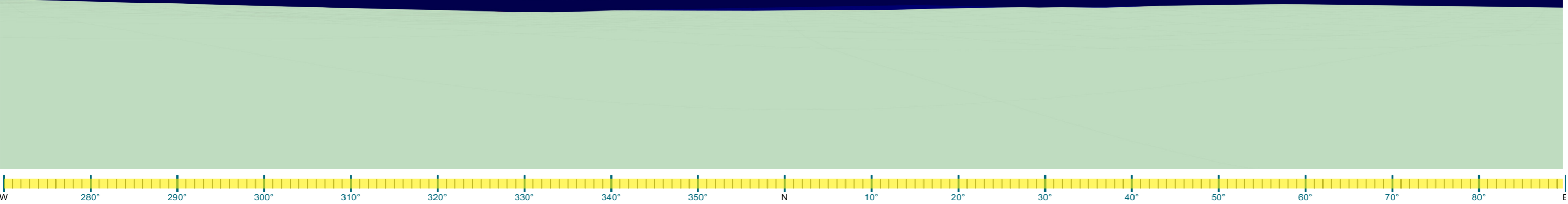

Dwelling/Public Viewpoint ID:

**PR\_24**

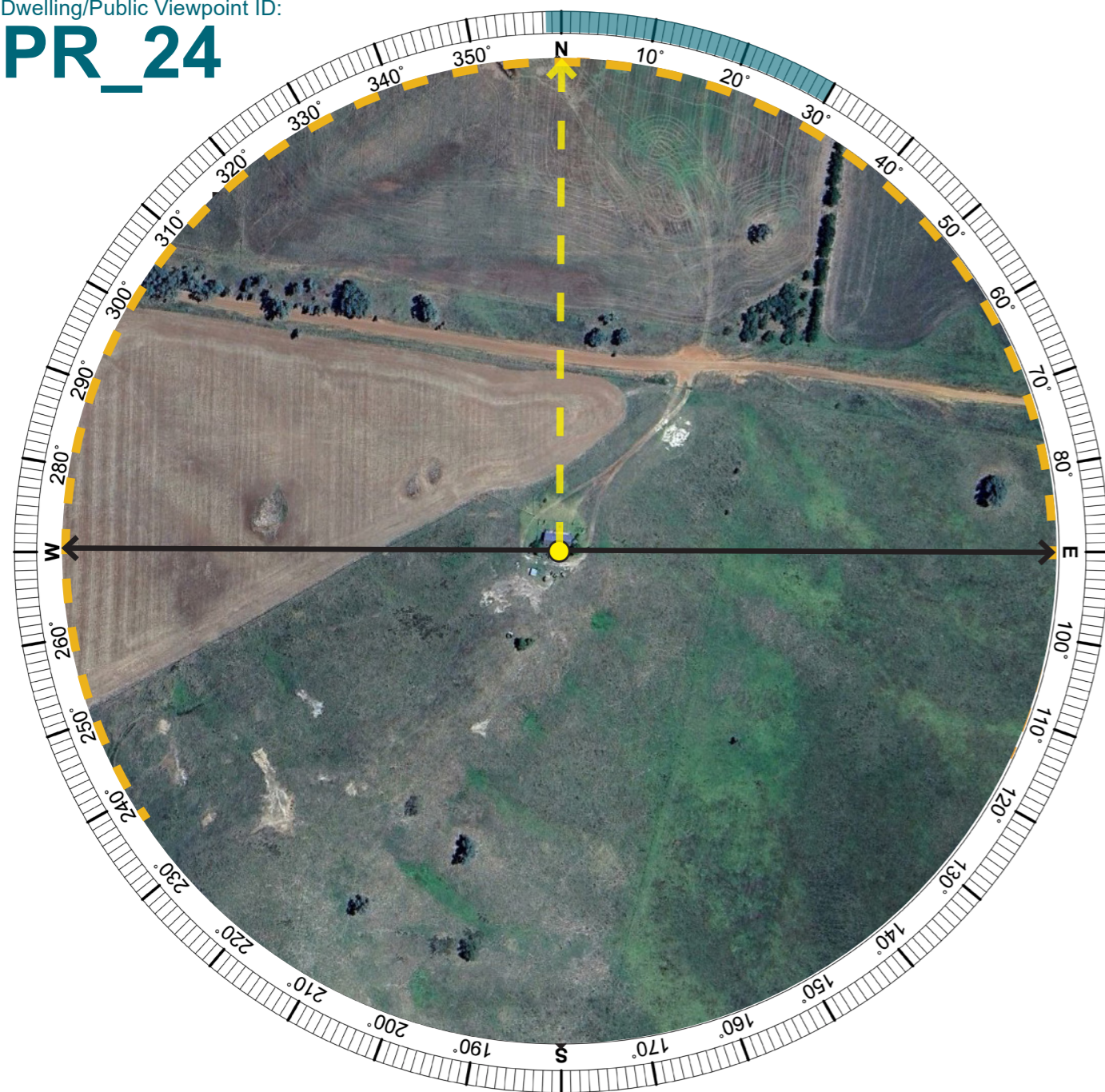

**LEGEND**

- The Project Extent - Potential visibility of the Project (Cobbora Solar Farm) (based on topography alone)
- Cumulative Extent - Potential visibility of surrounding projects (DSF/SCSF/The Project) (based on topography alone)
- Direction of the Wireframe
- Extent of Panorama
- Location of the viewpoint

Aerial Image - Wireframe Location (Aerial Image Source: Google Earth 2023)

**Residential Receptor PR\_24**

Receptor Assessment:								
Coordinates	Distance to development:	Viewpoint Type:	Receptor Sensitivity:	Scenic Quality:	Overall Sensitivity:	Total Occupied Cells:	Magnitude Rating:	Preliminary Visual Impact Rating:
32°12'30.57"S 149°14'31.25"E	2.13 km	Residential Receptor	Moderate	Low	Moderate	30	High	Moderate

OCCUPIED CELL COUNT (SOLAR FARM)		Cobbora Solar Farm (The Project)	Sandy Creek Solar Farm	Dapper Solar Farm
<div style="display: flex; align-items: center;"> <div style="width: 15px; height: 10px; background-color: #c0392b; margin-right: 5px;"></div> <span>Occupied Cell (greater than 25%)</span> </div> <p style="font-size: 8px; margin-top: 5px;">A cell is unoccupied if elements of the project, including solar panels, battery energy systems, or other associated infrastructure do not occupy more than approximately 25% of a cell.</p>	<b>Occupied Cells Per Project</b>	0	26	5

PR\_24  
Residential Receptor

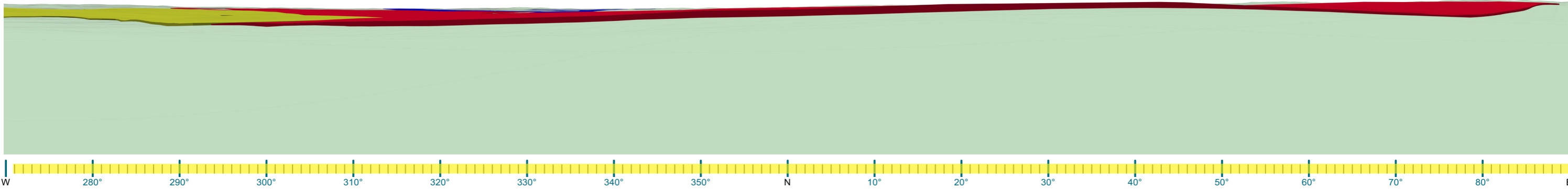

Cumulative Extent - Potential visibility of surrounding projects (based on topography alone)

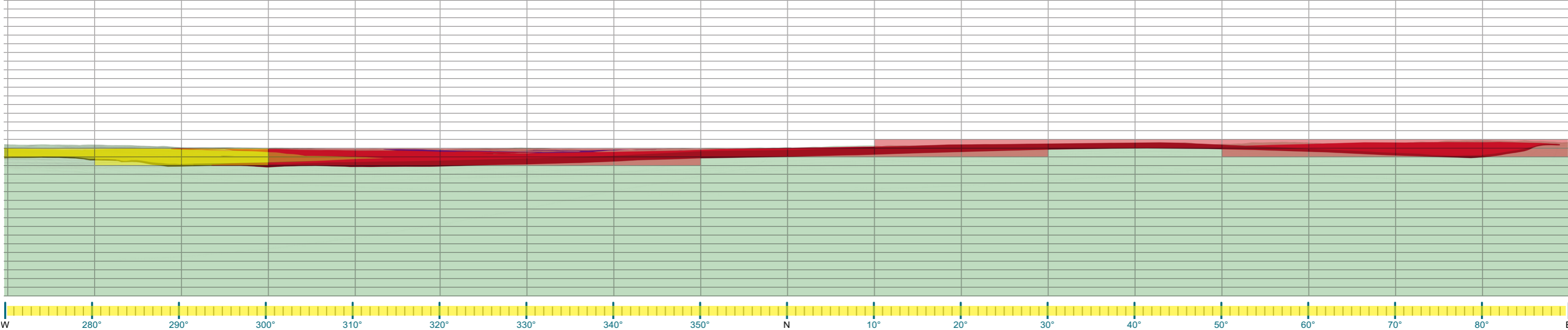
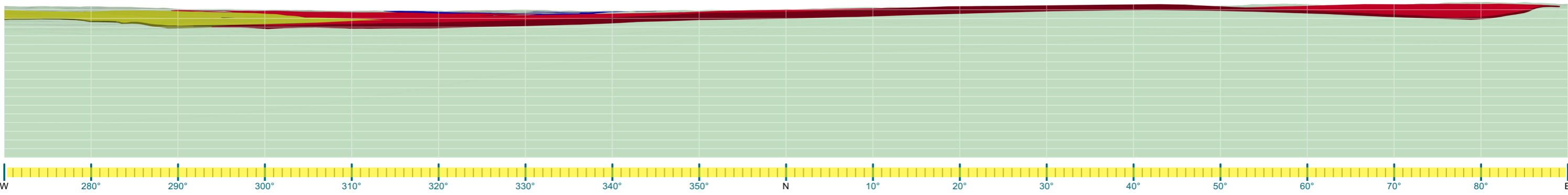

Dwelling/Public Viewpoint ID:

**PR\_30**

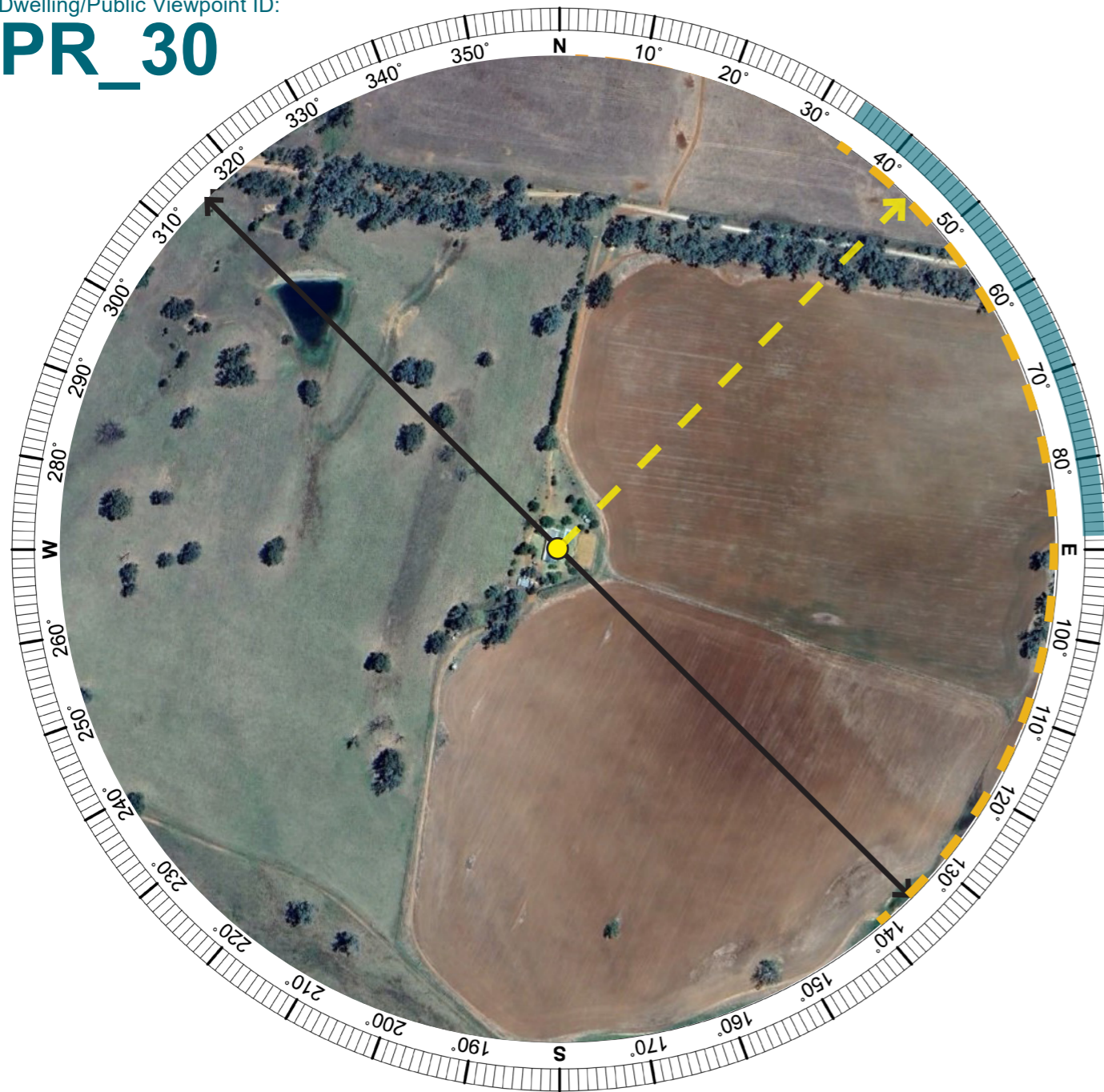

**LEGEND**

- The Project Extent - Potential visibility of the Project (Cobborra Solar Farm) (based on topography alone)
- Cumulative Extent - Potential visibility of surrounding projects (DSF/SCSF/The Project) (based on topography alone)
- ➔ Direction of the Wireframe
- ↔ Extent of Panorama
- Location of the viewpoint

Aerial Image - Wireframe Location (Aerial Image Source: Google Earth 2023)

**Residential Receptor PR\_30**

**Receptor Assessment:**

Coordinates	Distance to development:	Viewpoint Type:	Receptor Sensitivity:	Scenic Quality:	Overall Sensitivity:	Total Occupied Cells:	Magnitude Rating:	Preliminary Visual Impact Rating:
32°11'12.21"S 149° 9'37.45"E	3.58 km	Residential Receptor	Moderate	Low	Moderate	13	Low	Low

**OCCUPIED CELL COUNT (SOLAR FARM)**

Occupied Cell (greater than 25%)  
A cell is unoccupied if elements of the project, including solar panels, battery energy systems, or other associated infrastructure do not occupy more than approximately 25% of a cell.

	Cobborra Solar Farm (The Project)	Sandy Creek Solar Farm	Dapper Solar Farm
<b>Occupied Cells Per Project</b>	2	9	2

PR\_30  
Residential Receptor

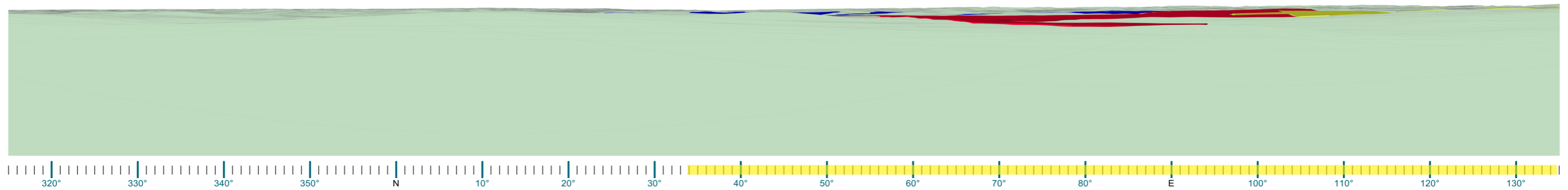

Cumulative Extent - Potential visibility of surrounding projects (based on topography alone)

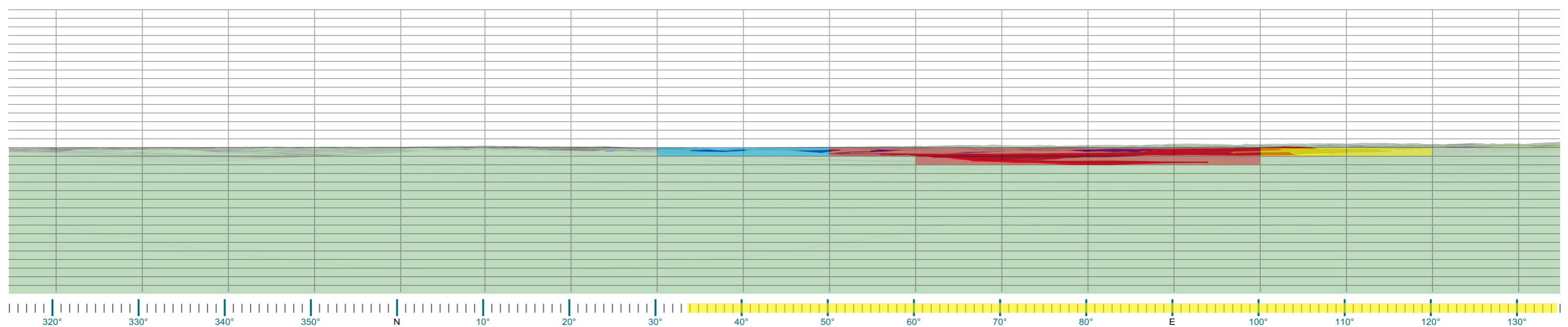
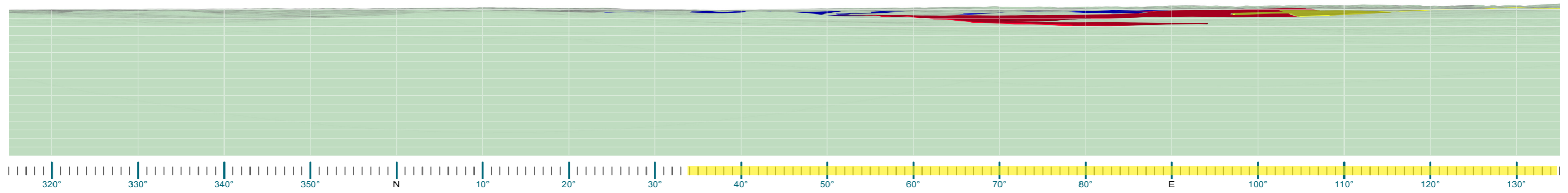

Dwelling/Public Viewpoint ID:

**X07**

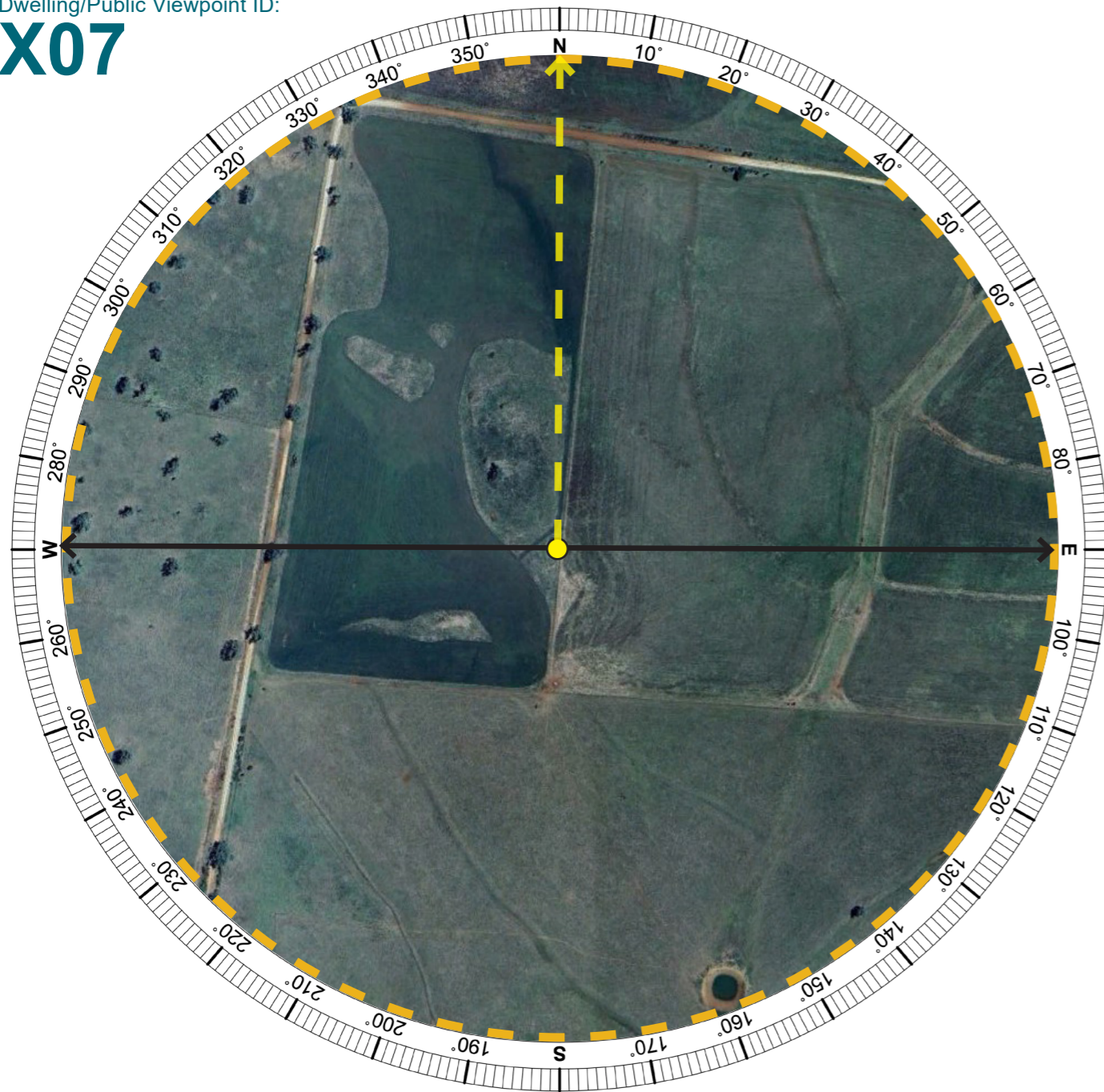

**NOTE:**  
The dwelling is located within the project boundary of Dapper Solar Farm, and the wireframe is mass modelled to the worst case scenario (to the project boundary). Consequently, the wireframe indicates that the entire view will be occupied by Dapper Solar Farm.

**LEGEND**

- The Project Extent - Potential visibility of the Project (Cobbora Solar Farm) (based on topography alone)
- Cumulative Extent - Potential visibility of surrounding projects (DSF/SCSF/The Project) (based on topography alone)
- ➔ Direction of the Wireframe
- Extent of Panorama
- Location of the viewpoint

Aerial Image - Wireframe Location (Aerial Image Source: Google Earth 2023)

**Residential Receptor X07**

Receptor Assessment:								
Coordinates	Distance to development:	Viewpoint Type:	Receptor Sensitivity:	Scenic Quality:	Overall Sensitivity:	Total Occupied Cells:	Magnitude Rating:	Preliminary Visual Impact Rating:
32°12'41.89"S 149°12'24.06"E	3.40 km	Residential Receptor	Moderate	Low	Moderate	NA	NA	NA

OCCUPIED CELL COUNT (SOLAR FARM)		Cobbora Solar Farm (The Project)	Sandy Creek Solar Farm	Dapper Solar Farm
<span style="display: inline-block; width: 15px; height: 10px; background-color: #C07040; border: 1px solid black; margin-right: 5px;"></span> Occupied Cell (greater than 25%) <small>A cell is unoccupied if elements of the project, including solar panels, battery energy systems, or other associated infrastructure do not occupy more than approximately 25% of a cell.</small>	<b>Occupied Cells Per Project</b>	0	0	Full View

X07  
Residential Receptor

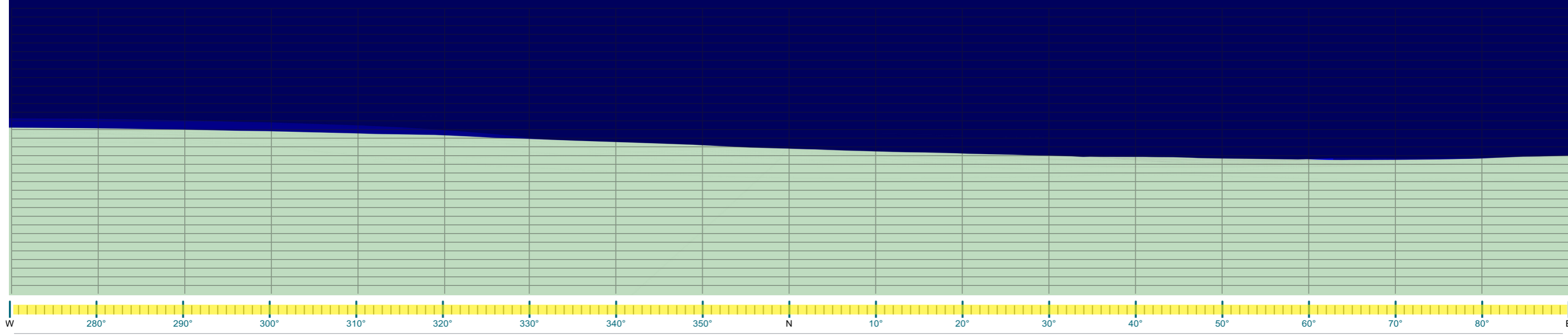
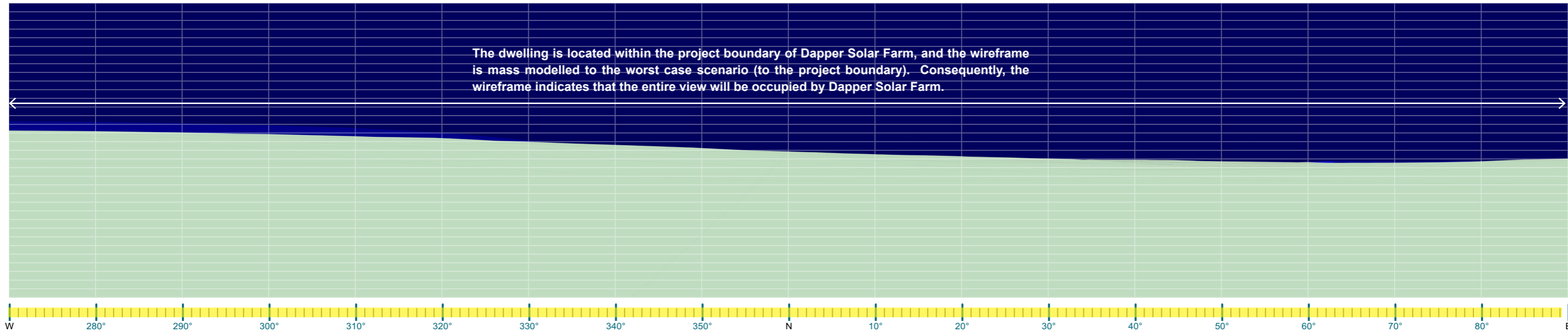
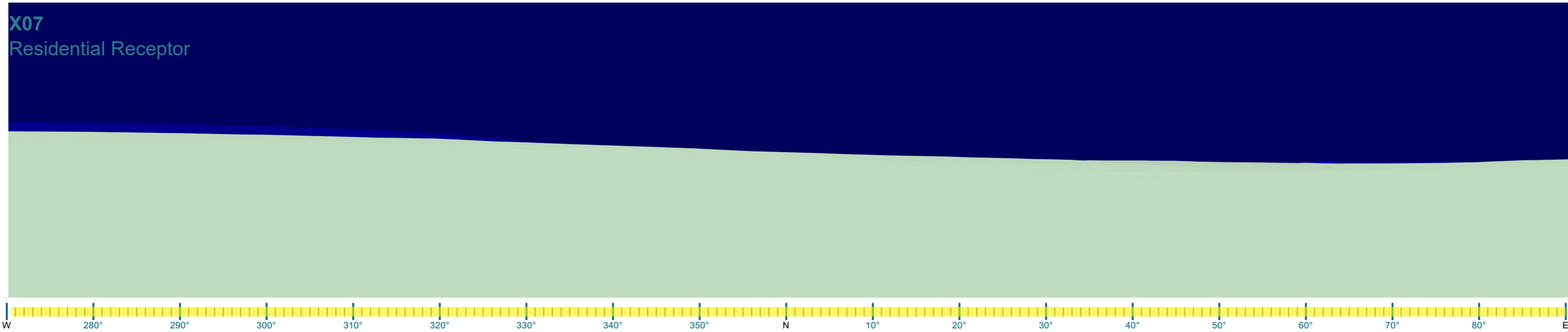

Dwelling/Public Viewpoint ID:

**X09**

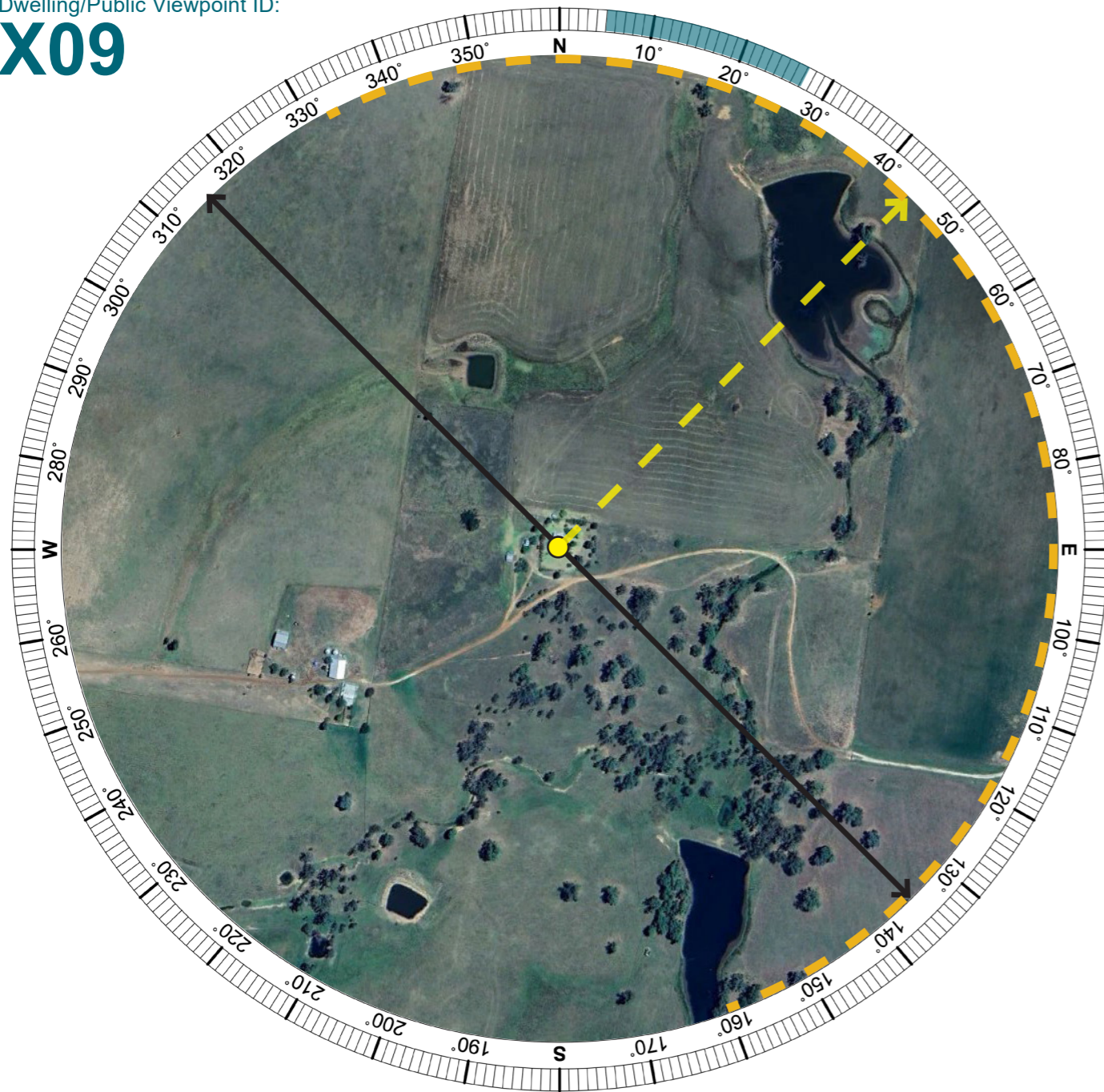

**LEGEND**

- The Project Extent - Potential visibility of the Project (Cobborra Solar Farm) (based on topography alone)
- Cumulative Extent - Potential visibility of surrounding projects (DSF/SCSF/The Project) (based on topography alone)
- Direction of the Wireframe
- ↔ Extent of Panorama
- Location of the viewpoint

Aerial Image - Wireframe Location (Aerial Image Source: Google Earth 2023)

**Residential Receptor X09**

**Receptor Assessment:**

Coordinates	Distance to development:	Viewpoint Type:	Receptor Sensitivity:	Scenic Quality:	Overall Sensitivity:	Total Occupied Cells:	Magnitude Rating:	Preliminary Visual Impact Rating:
32°12'26.50"S 149°11'37.23"E	3.68 km	Residential Receptor	Moderate	Low	Moderate	21	Moderate	Moderate

**OCCUPIED CELL COUNT (SOLAR FARM)**

Occupied Cell (greater than 25%)  
 A cell is unoccupied if elements of the project, including solar panels, battery energy systems, or other associated infrastructure do not occupy more than approximately 25% of a cell.

	Cobborra Solar Farm (The Project)	Sandy Creek Solar Farm	Dapper Solar Farm
<b>Occupied Cells Per Project</b>	0	0	21

X09  
Residential Receptor

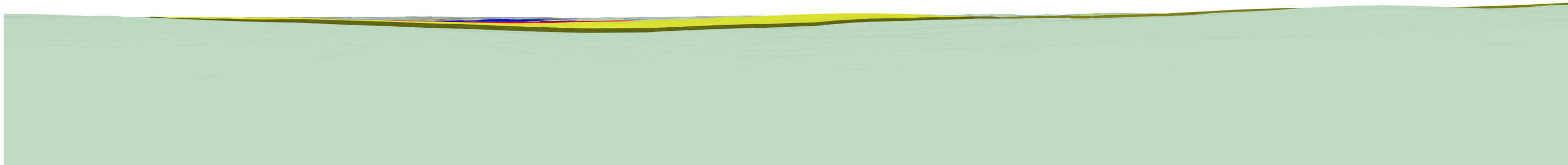

Cumulative Extent - Potential visibility of surrounding projects (based on topography alone)

