

ROADWORKS NOTES:

1. ALL ROADWORKS TO BE COMPLETED TO FAIRFIELD COUNCIL SPECIFICATIONS AND MODEL DRAWINGS CURRENT AT TIME OF CONSTRUCTION BY AN ACCREDITED CONTRACTOR.
2. FINAL ROADWORK LAYOUT SUBJECT TO COUNCIL APPROVAL.
3. CONTRACTOR TO RESOLVE ALL EXISTING & NEW SERVICE RELOCATION PRIOR TO COMMENCEMENT OF WORKS IN ACCORDANCE WITH THE RELEVANT GOVERNING BODIES SPECIFICATIONS & CONSULTANTS DOCUMENTATION.
4. ALL LINEMARKING TO CONFORM TO R.M.S Q&A SPECIFICATIONS R145. REFER TO THIS DOCUMENT FOR LINE TYPES, DIMENSIONS & MARKER SPACING.
5. ALL TRANSVERSE LINEMARKING, PAVEMENT ARROWS AND CHEVRONS TO BE MARKED USING THERMOPLASTIC.
6. REMOVE ALL EXISTING LINEMARKING BY GRIT BLASTING TO R.M.S. REQUIREMENTS TO ALLOW FOR MARKING OF NEW INTERSECTION LAYOUTS.
7. ALL AREAS BETWEEN THE NEW KERB AND PROPERTY BOUNDARY TO BE TOPSOILED (100mm MIN.) AND TURFED.

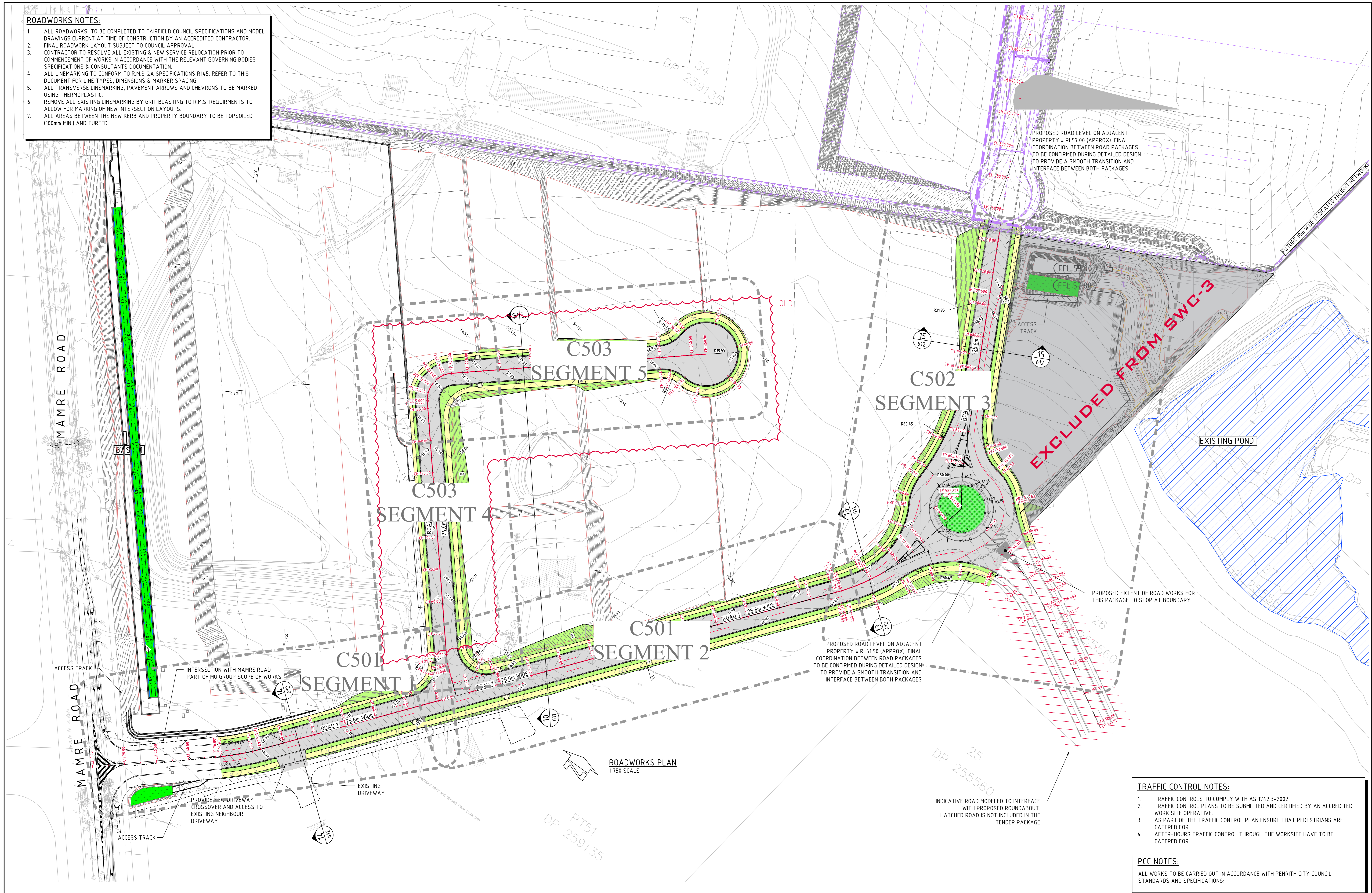

- TRAFFIC CONTROL NOTES:**
1. TRAFFIC CONTROLS TO COMPLY WITH AS 1742.3-2002
 2. TRAFFIC CONTROL PLANS TO BE SUBMITTED AND CERTIFIED BY AN ACCREDITED WORK SITE OPERATIVE.
 3. AS PART OF THE TRAFFIC CONTROL PLAN ENSURE THAT PEDESTRIANS ARE CATERED FOR.
 4. AFTER-HOURS TRAFFIC CONTROL THROUGH THE WORKSITE HAVE TO BE CATERED FOR.

PCC NOTES:
 ALL WORKS TO BE CARRIED OUT IN ACCORDANCE WITH PENRITH CITY COUNCIL STANDARDS AND SPECIFICATIONS.

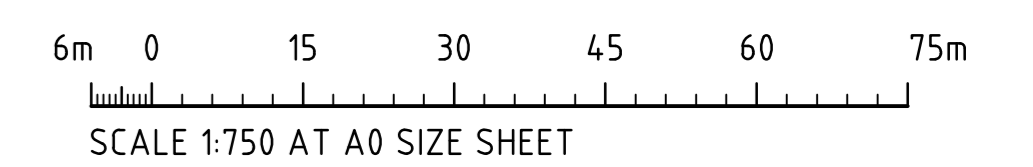

FOR SWC-3

ISSUED FOR SWC-2	19.12.24	3
ISSUED FOR CONSTRUCTION	24.07.24	2
ISSUED FOR CONSTRUCTION	28.05.24	1
ISSUED FOR CONSTRUCTION	02.05.24	0
REVISED AS ELUCIDATED	09.04.24	B
ISSUED FOR PRELIMINARY ONLY	15.03.24	A

ISSUED FOR SWC-3	21.02.25	4
AMENDMENTS	DATE	ISSUE

PROJECT MANAGER

ARCHITECT

CLIENT

PROJECT
ACCESS LOGISTICS PARK
 884-928 MAMRE ROAD
 KEMPS CREEK, NSW
 DESIGNED DRAWN DATE CHECKED SIZE SCALE CAD REF.
 DW SE MAR 24 MW AD AS SHOWN C01402105-C 500

CONSULT AUSTRALIA

 Costin Roe Consulting Pty Ltd.
 AIN 50 003 696 446
 PO Box 9419 Sydney NSW 1520
 Levels 4 & 5 Westfield Street, Mollies Point NSW 2000
 p: +61 2 9251 7699 e: mail@costinroe.com.au w: costinroe.com.au

CRC
 COSTIN ROE CONSULTING

DRAWING TITLE
ROADWORKS MASTER PLAN
 DRAWING No **C01402105-C500** ISSUE **4**

TRAFFIC CONTROL NOTES:

1. TRAFFIC CONTROLS TO COMPLY WITH AS 1742.3-2002
2. TRAFFIC CONTROL PLANS TO BE SUBMITTED AND CERTIFIED BY AN ACCREDITED WORK SITE OPERATIVE.
3. AS PART OF THE TRAFFIC CONTROL PLAN ENSURE THAT PEDESTRIANS ARE CATERED FOR.
4. AFTER-HOURS TRAFFIC CONTROL THROUGH THE WORKSITE HAVE TO BE CATERED FOR.

PCC NOTES:

ALL WORKS TO BE CARRIED OUT IN ACCORDANCE WITH PENRITH CITY COUNCIL STANDARDS AND SPECIFICATIONS:

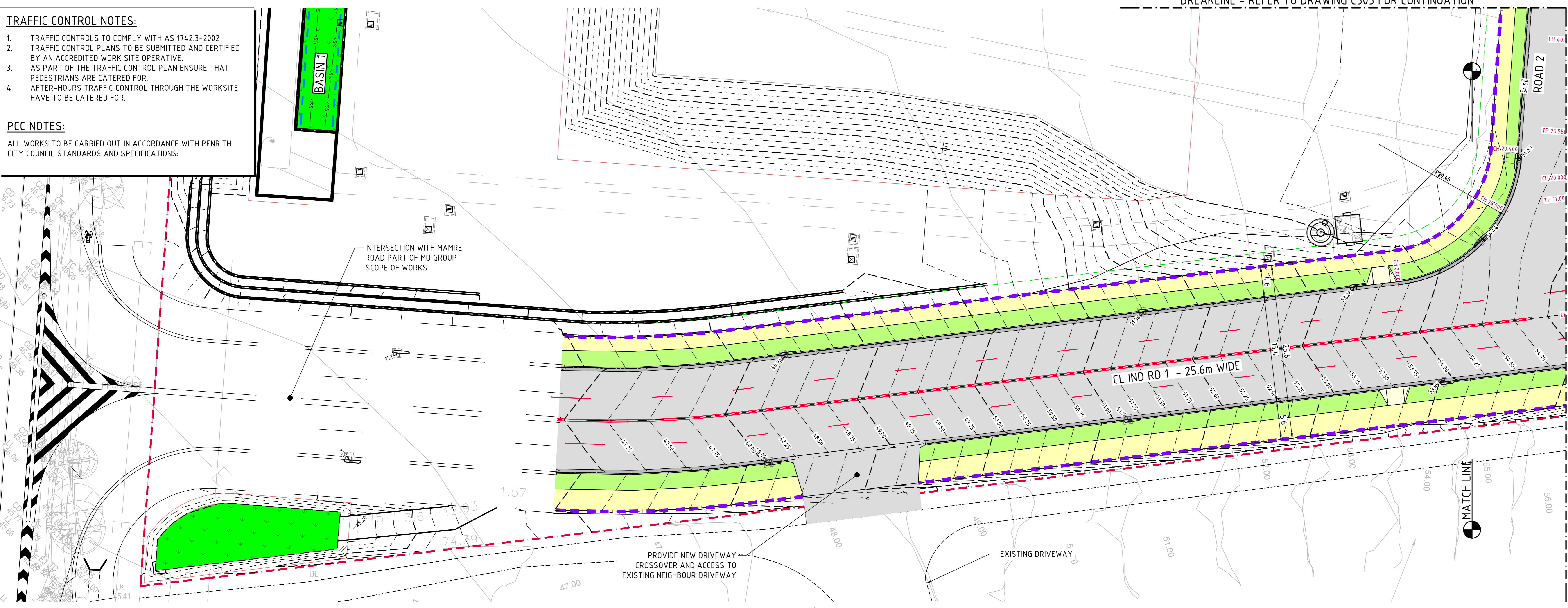

LEGEND:

LEVELS DATUM IS AHD.

EXISTING SITE LEVELS AND DETAILS BASED ON SURVEY INFORMATION PROVIDED BY 'LANDPARTNERS' DATED 25.03.2021.

- EXTENT OF ROAD PAVEMENT
- EXTENT OF FOOTPATH PAVEMENT
- K&G, KERB & GUTTER
- S.J.P, SEALED JUNCTION PIT
- K.I.P, KERB INLET PIT
- 59.00 - FINISHED PAVEMENT CONTOUR (MAJOR) 1.0m INTERVALS
- 59.25 - FINISHED PAVEMENT CONTOUR (MINOR) 0.25m INTERVALS

ROADWORKS PLAN - SEGMENT 1
SCALE 1:250

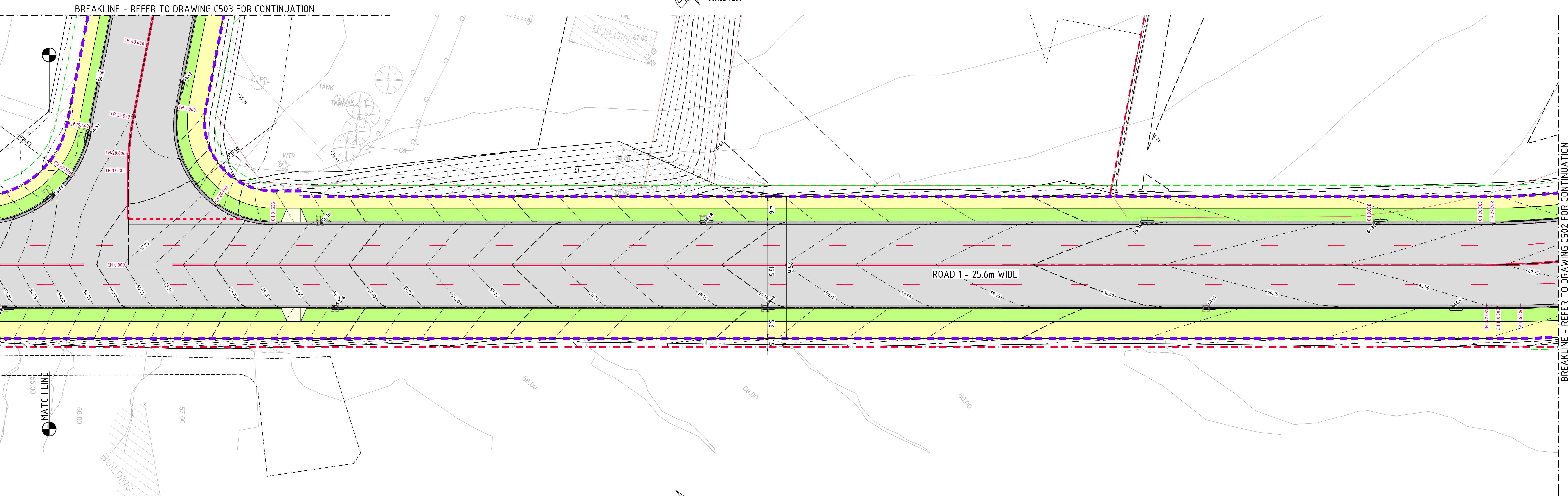

ROADWORKS PLAN - SEGMENT 2
SCALE 1:250

FOR SWC-3

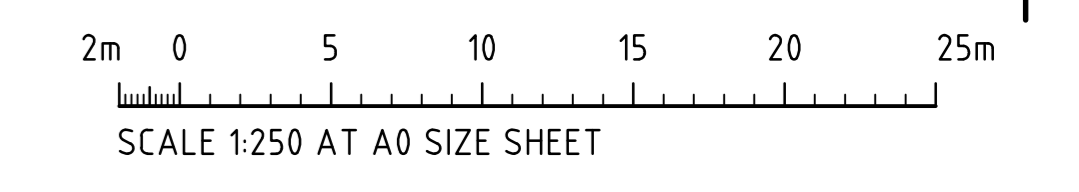

ISSUED FOR	DATE	ISSUE	AMENDMENTS
ISSUED FOR SWC-3	21.02.25	2	
ISSUED FOR CONSTRUCTION	24.07.24	1	
ISSUED FOR CONSTRUCTION	02.05.24	0	
ISSUED FOR PRELIMINARY ONLY	15.03.24	A	

DATE	ISSUE	AMENDMENTS	DATE	ISSUE	AMENDMENTS

PROJECT MANAGER
ProjectStrategy

ARCHITECT
nettleton|tibe

CLIENT
BURTON
Civil Engineering Contractors

PROJECT
ACCESS LOGISTICS PARK
884-928 MAMRE ROAD
KEMPS CREEK, NSW

CONSULT AUSTRALIA

Costin Roe Consulting Pty Ltd.
ABN 50 003 696 446
PO Box 7419 Sydney NSW 1520
Level 4, 4 Woodmill Street, Millers Point NSW 2000
p: +61 2 9251 7699 e: +61 2 9241 3731
e: mail@costinroe.com.au w: costinroe.com.au

CRC
COSTIN ROE CONSULTING
CIVIL & STRUCTURAL ENGINEERS

DRAWING TITLE
ROADWORKS PLAN SHEET 1
DRAWING No C014021.05-C501
ISSUE 2

BREAKLINE - REFER TO DRAWING C501 FOR CONTINUATION

LOT 11
PAD RL 59.92

A
571

PROPOSED ROAD LEVEL ON ADJACENT PROPERTY = RL6150 (APPROX). FINAL COORDINATION BETWEEN ROAD PACKAGES TO BE CONFIRMED DURING DETAILED DESIGN TO PROVIDE A SMOOTH TRANSITION AND INTERFACE BETWEEN BOTH PACKAGES

INDICATIVE ROAD MODELED TO INTERFACE WITH PROPOSED ROUNDABOUT. HATCHED ROAD IS NOT INCLUDED IN THE TENDER PACKAGE

PROPOSED ROAD LEVEL ON ADJACENT PROPERTY = RL57.00 (APPROX). FINAL COORDINATION BETWEEN ROAD PACKAGES TO BE CONFIRMED DURING DETAILED DESIGN TO PROVIDE A SMOOTH TRANSITION AND INTERFACE BETWEEN BOTH PACKAGES

LOT 12
PAD RL 60.22
EXCLUDED FROM SWC-3

PROPOSED EXTENT OF ROAD WORKS FOR THIS PACKAGE TO STOP AT BOUNDARY. PROVIDE TEMPORARY DISH DRAIN AND BATTER

B
C570

LEGEND:
LEVELS DATUM IS AHD.

EXISTING SITE LEVELS AND DETAILS BASED ON SURVEY INFORMATION PROVIDED BY 'LANDPARTNERS' DATED 25.03.2021.

- EXTENT OF ROAD PAVEMENT
- EXTENT OF FOOTPATH PAVEMENT
- K&G, KERB & GUTTER
- S.J.P, SEALED JUNCTION PIT
- KIP, KERB INLET PIT
- FINISHED PAVEMENT CONTOUR (MAJOR) 1.0m INTERVALS
- FINISHED PAVEMENT CONTOUR (MINOR) 0.25m INTERVALS

- TRAFFIC CONTROL NOTES:**
1. TRAFFIC CONTROLS TO COMPLY WITH AS 1742.3-2002
 2. TRAFFIC CONTROL PLANS TO BE SUBMITTED AND CERTIFIED BY AN ACCREDITED WORK SITE OPERATIVE.
 3. AS PART OF THE TRAFFIC CONTROL PLAN ENSURE THAT PEDESTRIANS ARE CATERED FOR.
 4. AFTER-HOURS TRAFFIC CONTROL THROUGH THE WORKSITE HAVE TO BE CATERED FOR.

PCC NOTES:
ALL WORKS TO BE CARRIED OUT IN ACCORDANCE WITH PENRITH CITY COUNCIL STANDARDS AND SPECIFICATIONS.

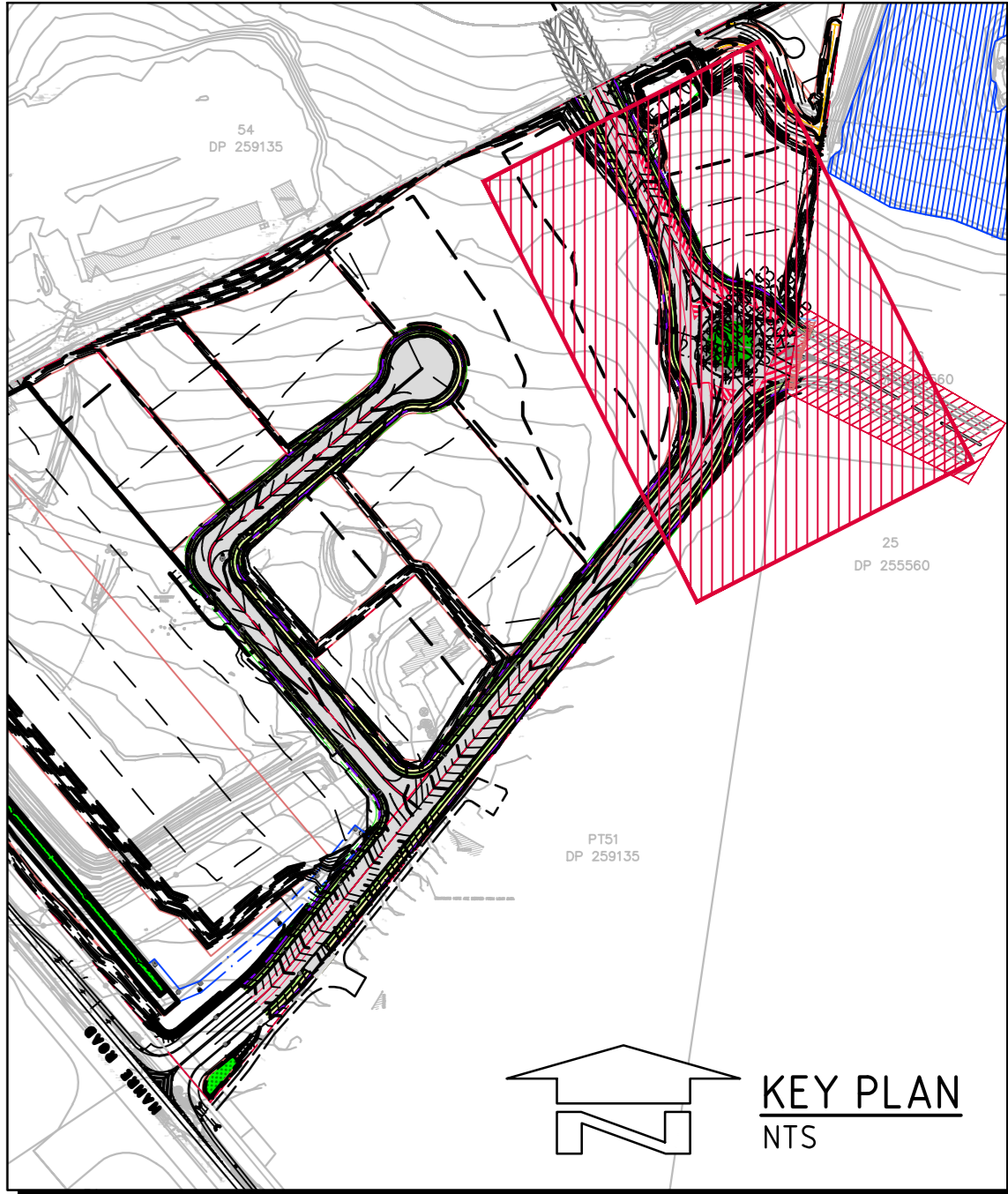

2m 0 5 10 15 20 25m
SCALE 1:250 AT A0 SIZE SHEET

FOR SWC-3

ROADWORKS PLAN - SEGMENT 3
SCALE 1:250

ISSUED FOR SWC-3	DATE	ISSUE	AMENDMENTS
ISSUED FOR SWC-3	08.04.25	3	
ISSUED FOR CONSTRUCTION	21.02.25	2	
ISSUED FOR CONSTRUCTION	24.07.24	1	
ISSUED FOR CONSTRUCTION	02.05.24	0	
ISSUED FOR PRELIMINARY ONLY	15.03.24	A	
AMENDMENTS	DATE	ISSUE	AMENDMENTS

PROJECT MANAGER
ProjectStrategy

ARCHITECT
nettleton|tibe

CLIENT
BURTON
Civil Engineering Contractors

PROJECT
ACCESS LOGISTICS PARK
884-928 MAMRE ROAD
KEMPS CREEK, NSW

CONSULT AUSTRALIA

Costin Roe Consulting Pty Ltd.
ABN 50 003 696 446
PO Box 9419 Sydney NSW 1520
Level 4, 4 Woodville Street, Mallett Point NSW 2000
p: +61 2 9251 7699 e: +61 2 9241 3731
e: mail@costinroe.com.au w: costinroe.com.au

CRC
COSTIN ROE CONSULTING
CIVIL & STRUCTURAL ENGINEERS

DRAWING TITLE
ROADWORKS PLAN SHEET 2
DRAWING No
C014021.05-C502

ISSUE
3

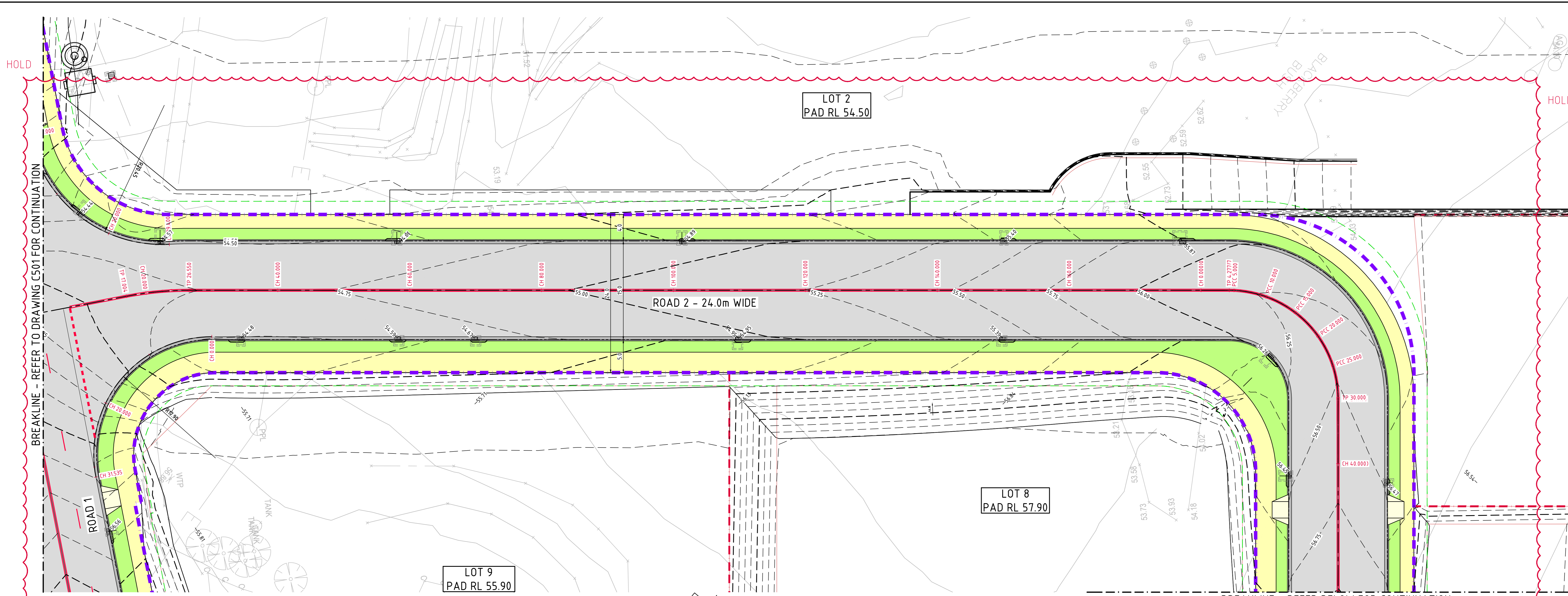

LEGEND:
 LEVELS DATUM IS AHD.
 EXISTING SITE LEVELS AND DETAILS BASED ON SURVEY INFORMATION PROVIDED BY 'LANDPARTNERS' DATED 25.03.2021.

- EXTENT OF ROAD PAVEMENT
- EXTENT OF FOOTPATH PAVEMENT
- K&G, KERB & GUTTER
- SJP, SEALED JUNCTION PIT
- KIP, KERB INLET PIT
- 50.00 - FINISHED PAVEMENT CONTOUR (MAJOR) 1.0m INTERVALS
- 50.25 - FINISHED PAVEMENT CONTOUR (MINOR) 0.25m INTERVALS

- TRAFFIC CONTROL NOTES:**
1. TRAFFIC CONTROLS TO COMPLY WITH AS 1742.3-2002
 2. TRAFFIC CONTROL PLANS TO BE SUBMITTED AND CERTIFIED BY AN ACCREDITED WORK SITE OPERATIVE.
 3. AS PART OF THE TRAFFIC CONTROL PLAN ENSURE THAT PEDESTRIANS ARE CATERED FOR.
 4. AFTER-HOURS TRAFFIC CONTROL THROUGH THE WORKSITE HAVE TO BE CATERED FOR.
- PCC NOTES:**
 ALL WORKS TO BE CARRIED OUT IN ACCORDANCE WITH PENRITH CITY COUNCIL STANDARDS AND SPECIFICATIONS.

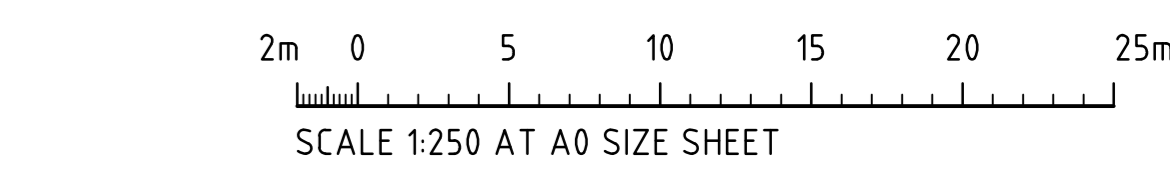
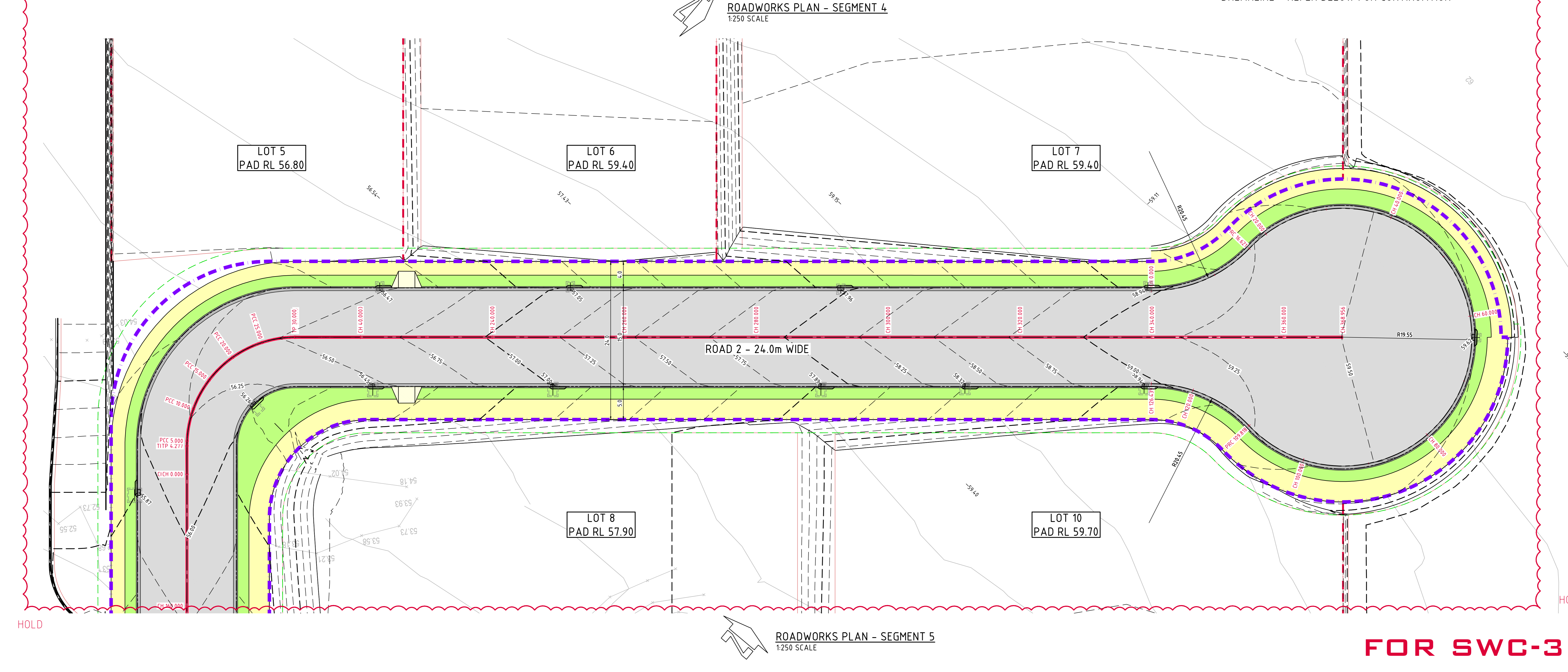

FOR SWC-3

<table border="1" style="width: 100%; border-collapse: collapse;"> <tr> <td style="font-size: 8px;">ISSUED FOR SWC-3</td> <td style="font-size: 8px;">21.02.25</td> <td style="font-size: 8px;">2</td> </tr> <tr> <td style="font-size: 8px;">ISSUED FOR CONSTRUCTION</td> <td style="font-size: 8px;">24.07.24</td> <td style="font-size: 8px;">1</td> </tr> <tr> <td style="font-size: 8px;">ISSUED FOR CONSTRUCTION</td> <td style="font-size: 8px;">02.05.24</td> <td style="font-size: 8px;">0</td> </tr> <tr> <td style="font-size: 8px;">ISSUED FOR PRELIMINARY ONLY</td> <td style="font-size: 8px;">15.03.24</td> <td style="font-size: 8px;">A</td> </tr> <tr> <td style="font-size: 8px;">AMENDMENTS</td> <td style="font-size: 8px;">DATE</td> <td style="font-size: 8px;">ISSUE</td> </tr> </table>	ISSUED FOR SWC-3	21.02.25	2	ISSUED FOR CONSTRUCTION	24.07.24	1	ISSUED FOR CONSTRUCTION	02.05.24	0	ISSUED FOR PRELIMINARY ONLY	15.03.24	A	AMENDMENTS	DATE	ISSUE	<table border="1" style="width: 100%; border-collapse: collapse;"> <tr> <td style="font-size: 8px;">PROJECT MANAGER</td> <td style="font-size: 8px;">ARCHITECT</td> <td style="font-size: 8px;">CLIENT</td> <td style="font-size: 8px;">PROJECT</td> </tr> <tr> <td style="font-size: 8px;">DESIGNED</td> <td style="font-size: 8px;">DRAWN</td> <td style="font-size: 8px;">DATE</td> <td style="font-size: 8px;">CHECKED</td> </tr> <tr> <td style="font-size: 8px;">DW</td> <td style="font-size: 8px;">AD</td> <td style="font-size: 8px;">AS SHOWN</td> <td style="font-size: 8px;">SCALE</td> </tr> <tr> <td style="font-size: 8px;">CAD REF.</td> <td colspan="3" style="font-size: 8px;">E-MAIL</td> </tr> </table>	PROJECT MANAGER	ARCHITECT	CLIENT	PROJECT	DESIGNED	DRAWN	DATE	CHECKED	DW	AD	AS SHOWN	SCALE	CAD REF.	E-MAIL			<table border="1" style="width: 100%; border-collapse: collapse;"> <tr> <td style="font-size: 8px;">PROJECT MANAGER</td> <td style="font-size: 8px;">ARCHITECT</td> <td style="font-size: 8px;">CLIENT</td> <td style="font-size: 8px;">PROJECT</td> </tr> <tr> <td style="font-size: 8px;">DESIGNED</td> <td style="font-size: 8px;">DRAWN</td> <td style="font-size: 8px;">DATE</td> <td style="font-size: 8px;">CHECKED</td> </tr> <tr> <td style="font-size: 8px;">DW</td> <td style="font-size: 8px;">AD</td> <td style="font-size: 8px;">AS SHOWN</td> <td style="font-size: 8px;">SCALE</td> </tr> <tr> <td style="font-size: 8px;">CAD REF.</td> <td colspan="3" style="font-size: 8px;">E-MAIL</td> </tr> </table>	PROJECT MANAGER	ARCHITECT	CLIENT	PROJECT	DESIGNED	DRAWN	DATE	CHECKED	DW	AD	AS SHOWN	SCALE	CAD REF.	E-MAIL			<table border="1" style="width: 100%; border-collapse: collapse;"> <tr> <td style="font-size: 8px;">PROJECT MANAGER</td> <td style="font-size: 8px;">ARCHITECT</td> <td style="font-size: 8px;">CLIENT</td> <td style="font-size: 8px;">PROJECT</td> </tr> <tr> <td style="font-size: 8px;">DESIGNED</td> <td style="font-size: 8px;">DRAWN</td> <td style="font-size: 8px;">DATE</td> <td style="font-size: 8px;">CHECKED</td> </tr> <tr> <td style="font-size: 8px;">DW</td> <td style="font-size: 8px;">AD</td> <td style="font-size: 8px;">AS SHOWN</td> <td style="font-size: 8px;">SCALE</td> </tr> <tr> <td style="font-size: 8px;">CAD REF.</td> <td colspan="3" style="font-size: 8px;">E-MAIL</td> </tr> </table>	PROJECT MANAGER	ARCHITECT	CLIENT	PROJECT	DESIGNED	DRAWN	DATE	CHECKED	DW	AD	AS SHOWN	SCALE	CAD REF.	E-MAIL			<table border="1" style="width: 100%; border-collapse: collapse;"> <tr> <td style="font-size: 8px;">PROJECT MANAGER</td> <td style="font-size: 8px;">ARCHITECT</td> <td style="font-size: 8px;">CLIENT</td> <td style="font-size: 8px;">PROJECT</td> </tr> <tr> <td style="font-size: 8px;">DESIGNED</td> <td style="font-size: 8px;">DRAWN</td> <td style="font-size: 8px;">DATE</td> <td style="font-size: 8px;">CHECKED</td> </tr> <tr> <td style="font-size: 8px;">DW</td> <td style="font-size: 8px;">AD</td> <td style="font-size: 8px;">AS SHOWN</td> <td style="font-size: 8px;">SCALE</td> </tr> <tr> <td style="font-size: 8px;">CAD REF.</td> <td colspan="3" style="font-size: 8px;">E-MAIL</td> </tr> </table>	PROJECT MANAGER	ARCHITECT	CLIENT	PROJECT	DESIGNED	DRAWN	DATE	CHECKED	DW	AD	AS SHOWN	SCALE	CAD REF.	E-MAIL			<table border="1" style="width: 100%; border-collapse: collapse;"> <tr> <td style="font-size: 8px;">PROJECT MANAGER</td> <td style="font-size: 8px;">ARCHITECT</td> <td style="font-size: 8px;">CLIENT</td> <td style="font-size: 8px;">PROJECT</td> </tr> <tr> <td style="font-size: 8px;">DESIGNED</td> <td style="font-size: 8px;">DRAWN</td> <td style="font-size: 8px;">DATE</td> <td style="font-size: 8px;">CHECKED</td> </tr> <tr> <td style="font-size: 8px;">DW</td> <td style="font-size: 8px;">AD</td> <td style="font-size: 8px;">AS SHOWN</td> <td style="font-size: 8px;">SCALE</td> </tr> <tr> <td style="font-size: 8px;">CAD REF.</td> <td colspan="3" style="font-size: 8px;">E-MAIL</td> </tr> </table>	PROJECT MANAGER	ARCHITECT	CLIENT	PROJECT	DESIGNED	DRAWN	DATE	CHECKED	DW	AD	AS SHOWN	SCALE	CAD REF.	E-MAIL			<table border="1" style="width: 100%; border-collapse: collapse;"> <tr> <td style="font-size: 8px;">PROJECT MANAGER</td> <td style="font-size: 8px;">ARCHITECT</td> <td style="font-size: 8px;">CLIENT</td> <td style="font-size: 8px;">PROJECT</td> </tr> <tr> <td style="font-size: 8px;">DESIGNED</td> <td style="font-size: 8px;">DRAWN</td> <td style="font-size: 8px;">DATE</td> <td style="font-size: 8px;">CHECKED</td> </tr> <tr> <td style="font-size: 8px;">DW</td> <td style="font-size: 8px;">AD</td> <td style="font-size: 8px;">AS SHOWN</td> <td style="font-size: 8px;">SCALE</td> </tr> <tr> <td style="font-size: 8px;">CAD REF.</td> <td colspan="3" style="font-size: 8px;">E-MAIL</td> </tr> </table>	PROJECT MANAGER	ARCHITECT	CLIENT	PROJECT	DESIGNED	DRAWN	DATE	CHECKED	DW	AD	AS SHOWN	SCALE	CAD REF.	E-MAIL			<table border="1" style="width: 100%; border-collapse: collapse;"> <tr> <td style="font-size: 8px;">PROJECT MANAGER</td> <td style="font-size: 8px;">ARCHITECT</td> <td style="font-size: 8px;">CLIENT</td> <td style="font-size: 8px;">PROJECT</td> </tr> <tr> <td style="font-size: 8px;">DESIGNED</td> <td style="font-size: 8px;">DRAWN</td> <td style="font-size: 8px;">DATE</td> <td style="font-size: 8px;">CHECKED</td> </tr> <tr> <td style="font-size: 8px;">DW</td> <td style="font-size: 8px;">AD</td> <td style="font-size: 8px;">AS SHOWN</td> <td style="font-size: 8px;">SCALE</td> </tr> <tr> <td style="font-size: 8px;">CAD REF.</td> <td colspan="3" style="font-size: 8px;">E-MAIL</td> </tr> </table>	PROJECT MANAGER	ARCHITECT	CLIENT	PROJECT	DESIGNED	DRAWN	DATE	CHECKED	DW	AD	AS SHOWN	SCALE	CAD REF.	E-MAIL			<table border="1" style="width: 100%; border-collapse: collapse;"> <tr> <td style="font-size: 8px;">PROJECT MANAGER</td> <td style="font-size: 8px;">ARCHITECT</td> <td style="font-size: 8px;">CLIENT</td> <td style="font-size: 8px;">PROJECT</td> </tr> <tr> <td style="font-size: 8px;">DESIGNED</td> <td style="font-size: 8px;">DRAWN</td> <td style="font-size: 8px;">DATE</td> <td style="font-size: 8px;">CHECKED</td> </tr> <tr> <td style="font-size: 8px;">DW</td> <td style="font-size: 8px;">AD</td> <td style="font-size: 8px;">AS SHOWN</td> <td style="font-size: 8px;">SCALE</td> </tr> <tr> <td style="font-size: 8px;">CAD REF.</td> <td colspan="3" style="font-size: 8px;">E-MAIL</td> </tr> </table>	PROJECT MANAGER	ARCHITECT	CLIENT	PROJECT	DESIGNED	DRAWN	DATE	CHECKED	DW	AD	AS SHOWN	SCALE	CAD REF.	E-MAIL			<table border="1" style="width: 100%; border-collapse: collapse;"> <tr> <td style="font-size: 8px;">PROJECT MANAGER</td> <td style="font-size: 8px;">ARCHITECT</td> <td style="font-size: 8px;">CLIENT</td> <td style="font-size: 8px;">PROJECT</td> </tr> <tr> <td style="font-size: 8px;">DESIGNED</td> <td style="font-size: 8px;">DRAWN</td> <td style="font-size: 8px;">DATE</td> <td style="font-size: 8px;">CHECKED</td> </tr> <tr> <td style="font-size: 8px;">DW</td> <td style="font-size: 8px;">AD</td> <td style="font-size: 8px;">AS SHOWN</td> <td style="font-size: 8px;">SCALE</td> </tr> <tr> <td style="font-size: 8px;">CAD REF.</td> <td colspan="3" style="font-size: 8px;">E-MAIL</td> </tr> </table>	PROJECT MANAGER	ARCHITECT	CLIENT	PROJECT	DESIGNED	DRAWN	DATE	CHECKED	DW	AD	AS SHOWN	SCALE	CAD REF.	E-MAIL			<table border="1" style="width: 100%; border-collapse: collapse;"> <tr> <td style="font-size: 8px;">PROJECT MANAGER</td> <td style="font-size: 8px;">ARCHITECT</td> <td style="font-size: 8px;">CLIENT</td> <td style="font-size: 8px;">PROJECT</td> </tr> <tr> <td style="font-size: 8px;">DESIGNED</td> <td style="font-size: 8px;">DRAWN</td> <td style="font-size: 8px;">DATE</td> <td style="font-size: 8px;">CHECKED</td> </tr> <tr> <td style="font-size: 8px;">DW</td> <td style="font-size: 8px;">AD</td> <td style="font-size: 8px;">AS SHOWN</td> <td style="font-size: 8px;">SCALE</td> </tr> <tr> <td style="font-size: 8px;">CAD REF.</td> <td colspan="3" style="font-size: 8px;">E-MAIL</td> </tr> </table>	PROJECT MANAGER	ARCHITECT	CLIENT	PROJECT	DESIGNED	DRAWN	DATE	CHECKED	DW	AD	AS SHOWN	SCALE	CAD REF.	E-MAIL			<table border="1" style="width: 100%; border-collapse: collapse;"> <tr> <td style="font-size: 8px;">PROJECT MANAGER</td> <td style="font-size: 8px;">ARCHITECT</td> <td style="font-size: 8px;">CLIENT</td> <td style="font-size: 8px;">PROJECT</td> </tr> <tr> <td style="font-size: 8px;">DESIGNED</td> <td style="font-size: 8px;">DRAWN</td> <td style="font-size: 8px;">DATE</td> <td style="font-size: 8px;">CHECKED</td> </tr> <tr> <td style="font-size: 8px;">DW</td> <td style="font-size: 8px;">AD</td> <td style="font-size: 8px;">AS SHOWN</td> <td style="font-size: 8px;">SCALE</td> </tr> <tr> <td style="font-size: 8px;">CAD REF.</td> <td colspan="3" style="font-size: 8px;">E-MAIL</td> </tr> </table>	PROJECT MANAGER	ARCHITECT	CLIENT	PROJECT	DESIGNED	DRAWN	DATE	CHECKED	DW	AD	AS SHOWN	SCALE	CAD REF.	E-MAIL			<table border="1" style="width: 100%; border-collapse: collapse;"> <tr> <td style="font-size: 8px;">PROJECT MANAGER</td> <td style="font-size: 8px;">ARCHITECT</td> <td style="font-size: 8px;">CLIENT</td> <td style="font-size: 8px;">PROJECT</td> </tr> <tr> <td style="font-size: 8px;">DESIGNED</td> <td style="font-size: 8px;">DRAWN</td> <td style="font-size: 8px;">DATE</td> <td style="font-size: 8px;">CHECKED</td> </tr> <tr> <td style="font-size: 8px;">DW</td> <td style="font-size: 8px;">AD</td> <td style="font-size: 8px;">AS SHOWN</td> <td style="font-size: 8px;">SCALE</td> </tr> <tr> <td style="font-size: 8px;">CAD REF.</td> <td colspan="3" style="font-size: 8px;">E-MAIL</td> </tr> </table>	PROJECT MANAGER	ARCHITECT	CLIENT	PROJECT	DESIGNED	DRAWN	DATE	CHECKED	DW	AD	AS SHOWN	SCALE	CAD REF.	E-MAIL			<table border="1" style="width: 100%; border-collapse: collapse;"> <tr> <td style="font-size: 8px;">PROJECT MANAGER</td> <td style="font-size: 8px;">ARCHITECT</td> <td style="font-size: 8px;">CLIENT</td> <td style="font-size: 8px;">PROJECT</td> </tr> <tr> <td style="font-size: 8px;">DESIGNED</td> <td style="font-size: 8px;">DRAWN</td> <td style="font-size: 8px;">DATE</td> <td style="font-size: 8px;">CHECKED</td> </tr> <tr> <td style="font-size: 8px;">DW</td> <td style="font-size: 8px;">AD</td> <td style="font-size: 8px;">AS SHOWN</td> <td style="font-size: 8px;">SCALE</td> </tr> <tr> <td style="font-size: 8px;">CAD REF.</td> <td colspan="3" style="font-size: 8px;">E-MAIL</td> </tr> </table>	PROJECT MANAGER	ARCHITECT	CLIENT	PROJECT	DESIGNED	DRAWN	DATE	CHECKED	DW	AD	AS SHOWN	SCALE	CAD REF.	E-MAIL			<table border="1" style="width: 100%; border-collapse: collapse;"> <tr> <td style="font-size: 8px;">PROJECT MANAGER</td> <td style="font-size: 8px;">ARCHITECT</td> <td style="font-size: 8px;">CLIENT</td> <td style="font-size: 8px;">PROJECT</td> </tr> <tr> <td style="font-size: 8px;">DESIGNED</td> <td style="font-size: 8px;">DRAWN</td> <td style="font-size: 8px;">DATE</td> <td style="font-size: 8px;">CHECKED</td> </tr> <tr> <td style="font-size: 8px;">DW</td> <td style="font-size: 8px;">AD</td> <td style="font-size: 8px;">AS SHOWN</td> <td style="font-size: 8px;">SCALE</td> </tr> <tr> <td style="font-size: 8px;">CAD REF.</td> <td colspan="3" style="font-size: 8px;">E-MAIL</td> </tr> </table>	PROJECT MANAGER	ARCHITECT	CLIENT	PROJECT	DESIGNED	DRAWN	DATE	CHECKED	DW	AD	AS SHOWN	SCALE	CAD REF.	E-MAIL			<table border="1" style="width: 100%; border-collapse: collapse;"> <tr> <td style="font-size: 8px;">PROJECT MANAGER</td> <td style="font-size: 8px;">ARCHITECT</td> <td style="font-size: 8px;">CLIENT</td> <td style="font-size: 8px;">PROJECT</td> </tr> <tr> <td style="font-size: 8px;">DESIGNED</td> <td style="font-size: 8px;">DRAWN</td> <td style="font-size: 8px;">DATE</td> <td style="font-size: 8px;">CHECKED</td> </tr> <tr> <td style="font-size: 8px;">DW</td> <td style="font-size: 8px;">AD</td> <td style="font-size: 8px;">AS SHOWN</td> <td style="font-size: 8px;">SCALE</td> </tr> <tr> <td style="font-size: 8px;">CAD REF.</td> <td colspan="3" style="font-size: 8px;">E-MAIL</td> </tr> </table>	PROJECT MANAGER	ARCHITECT	CLIENT	PROJECT	DESIGNED	DRAWN	DATE	CHECKED	DW	AD	AS SHOWN	SCALE	CAD REF.	E-MAIL			<table border="1" style="width: 100%; border-collapse: collapse;"> <tr> <td style="font-size: 8px;">PROJECT MANAGER</td> <td style="font-size: 8px;">ARCHITECT</td> <td style="font-size: 8px;">CLIENT</td> <td style="font-size: 8px;">PROJECT</td> </tr> <tr> <td style="font-size: 8px;">DESIGNED</td> <td style="font-size: 8px;">DRAWN</td> <td style="font-size: 8px;">DATE</td> <td style="font-size: 8px;">CHECKED</td> </tr> <tr> <td style="font-size: 8px;">DW</td> <td style="font-size: 8px;">AD</td> <td style="font-size: 8px;">AS SHOWN</td> <td style="font-size: 8px;">SCALE</td> </tr> <tr> <td style="font-size: 8px;">CAD REF.</td> <td colspan="3" style="font-size: 8px;">E-MAIL</td> </tr> </table>	PROJECT MANAGER	ARCHITECT	CLIENT	PROJECT	DESIGNED	DRAWN	DATE	CHECKED	DW	AD	AS SHOWN	SCALE	CAD REF.	E-MAIL			<table border="1" style="width: 100%; border-collapse: collapse;"> <tr> <td style="font-size: 8px;">PROJECT MANAGER</td> <td style="font-size: 8px;">ARCHITECT</td> <td style="font-size: 8px;">CLIENT</td> <td style="font-size: 8px;">PROJECT</td> </tr> <tr> <td style="font-size: 8px;">DESIGNED</td> <td style="font-size: 8px;">DRAWN</td> <td style="font-size: 8px;">DATE</td> <td style="font-size: 8px;">CHECKED</td> </tr> <tr> <td style="font-size: 8px;">DW</td> <td style="font-size: 8px;">AD</td> <td style="font-size: 8px;">AS SHOWN</td> <td style="font-size: 8px;">SCALE</td> </tr> <tr> <td style="font-size: 8px;">CAD REF.</td> <td colspan="3" style="font-size: 8px;">E-MAIL</td> </tr> </table>	PROJECT MANAGER	ARCHITECT	CLIENT	PROJECT	DESIGNED	DRAWN	DATE	CHECKED	DW	AD	AS SHOWN	SCALE	CAD REF.	E-MAIL			<table border="1" style="width: 100%; border-collapse: collapse;"> <tr> <td style="font-size: 8px;">PROJECT MANAGER</td> <td style="font-size: 8px;">ARCHITECT</td> <td style="font-size: 8px;">CLIENT</td> <td style="font-size: 8px;">PROJECT</td> </tr> <tr> <td style="font-size: 8px;">DESIGNED</td> <td style="font-size: 8px;">DRAWN</td> <td style="font-size: 8px;">DATE</td> <td style="font-size: 8px;">CHECKED</td> </tr> <tr> <td style="font-size: 8px;">DW</td> <td style="font-size: 8px;">AD</td> <td style="font-size: 8px;">AS SHOWN</td> <td style="font-size: 8px;">SCALE</td> </tr> <tr> <td style="font-size: 8px;">CAD REF.</td> <td colspan="3" style="font-size: 8px;">E-MAIL</td> </tr> </table>	PROJECT MANAGER	ARCHITECT	CLIENT	PROJECT	DESIGNED	DRAWN	DATE	CHECKED	DW	AD	AS SHOWN	SCALE	CAD REF.	E-MAIL			<table border="1" style="width: 100%; border-collapse: collapse;"> <tr> <td style="font-size: 8px;">PROJECT MANAGER</td> <td style="font-size: 8px;">ARCHITECT</td> <td style="font-size: 8px;">CLIENT</td> <td style="font-size: 8px;">PROJECT</td> </tr> <tr> <td style="font-size: 8px;">DESIGNED</td> <td style="font-size: 8px;">DRAWN</td> <td style="font-size: 8px;">DATE</td> <td style="font-size: 8px;">CHECKED</td> </tr> <tr> <td style="font-size: 8px;">DW</td> <td style="font-size: 8px;">AD</td> <td style="font-size: 8px;">AS SHOWN</td> <td style="font-size: 8px;">SCALE</td> </tr> <tr> <td style="font-size: 8px;">CAD REF.</td> <td colspan="3" style="font-size: 8px;">E-MAIL</td> </tr> </table>	PROJECT MANAGER	ARCHITECT	CLIENT	PROJECT	DESIGNED	DRAWN	DATE	CHECKED	DW	AD	AS SHOWN	SCALE	CAD REF.	E-MAIL			<table border="1" style="width: 100%; border-collapse: collapse;"> <tr> <td style="font-size: 8px;">PROJECT MANAGER</td> <td style="font-size: 8px;">ARCHITECT</td> <td style="font-size: 8px;">CLIENT</td> <td style="font-size: 8px;">PROJECT</td> </tr> <tr> <td style="font-size: 8px;">DESIGNED</td> <td style="font-size: 8px;">DRAWN</td> <td style="font-size: 8px;">DATE</td> <td style="font-size: 8px;">CHECKED</td> </tr> <tr> <td style="font-size: 8px;">DW</td> <td style="font-size: 8px;">AD</td> <td style="font-size: 8px;">AS SHOWN</td> <td style="font-size: 8px;">SCALE</td> </tr> <tr> <td style="font-size: 8px;">CAD REF.</td> <td colspan="3" style="font-size: 8px;">E-MAIL</td> </tr> </table>	PROJECT MANAGER	ARCHITECT	CLIENT	PROJECT	DESIGNED	DRAWN	DATE	CHECKED	DW	AD	AS SHOWN	SCALE	CAD REF.	E-MAIL			<table border="1" style="width: 100%; border-collapse: collapse;"> <tr> <td style="font-size: 8px;">PROJECT MANAGER</td> <td style="font-size: 8px;">ARCHITECT</td> <td style="font-size: 8px;">CLIENT</td> <td style="font-size: 8px;">PROJECT</td> </tr> <tr> <td style="font-size: 8px;">DESIGNED</td> <td style="font-size: 8px;">DRAWN</td> <td style="font-size: 8px;">DATE</td> <td style="font-size: 8px;">CHECKED</td> </tr> <tr> <td style="font-size: 8px;">DW</td> <td style="font-size: 8px;">AD</td> <td style="font-size: 8px;">AS SHOWN</td> <td style="font-size: 8px;">SCALE</td> </tr> <tr> <td style="font-size: 8px;">CAD REF.</td> <td colspan="3" style="font-size: 8px;">E-MAIL</td> </tr> </table>	PROJECT MANAGER	ARCHITECT	CLIENT	PROJECT	DESIGNED	DRAWN	DATE	CHECKED	DW	AD	AS SHOWN	SCALE	CAD REF.	E-MAIL			<table border="1" style="width: 100%; border-collapse: collapse;"> <tr> <td style="font-size: 8px;">PROJECT MANAGER</td> <td style="font-size: 8px;">ARCHITECT</td> <td style="font-size: 8px;">CLIENT</td> <td style="font-size: 8px;">PROJECT</td> </tr> <tr> <td style="font-size: 8px;">DESIGNED</td> <td style="font-size: 8px;">DRAWN</td> <td style="font-size: 8px;">DATE</td> <td style="font-size: 8px;">CHECKED</td> </tr> <tr> <td style="font-size: 8px;">DW</td> <td style="font-size: 8px;">AD</td> <td style="font-size: 8px;">AS SHOWN</td> <td style="font-size: 8px;">SCALE</td> </tr> <tr> <td style="font-size: 8px;">CAD REF.</td> <td colspan="3" style="font-size: 8px;">E-MAIL</td> </tr> </table>	PROJECT MANAGER	ARCHITECT	CLIENT	PROJECT	DESIGNED	DRAWN	DATE	CHECKED	DW	AD	AS SHOWN	SCALE	CAD REF.	E-MAIL			<table border="1" style="width: 100%; border-collapse: collapse;"> <tr> <td style="font-size: 8px;">PROJECT MANAGER</td> <td style="font-size: 8px;">ARCHITECT</td> <td style="font-size: 8px;">CLIENT</td> <td style="font-size: 8px;">PROJECT</td> </tr> <tr> <td style="font-size: 8px;">DESIGNED</td> <td style="font-size: 8px;">DRAWN</td> <td style="font-size: 8px;">DATE</td> <td style="font-size: 8px;">CHECKED</td> </tr> <tr> <td style="font-size: 8px;">DW</td> <td style="font-size: 8px;">AD</td> <td style="font-size: 8px;">AS SHOWN</td> <td style="font-size: 8px;">SCALE</td> </tr> <tr> <td style="font-size: 8px;">CAD REF.</td> <td colspan="3" style="font-size: 8px;">E-MAIL</td> </tr> </table>	PROJECT MANAGER	ARCHITECT	CLIENT	PROJECT	DESIGNED	DRAWN	DATE	CHECKED	DW	AD	AS SHOWN	SCALE	CAD REF.	E-MAIL			<table border="1" style="width: 100%; border-collapse: collapse;"> <tr> <td style="font-size: 8px;">PROJECT MANAGER</td> <td style="font-size: 8px;">ARCHITECT</td> <td style="font-size: 8px;">CLIENT</td> <td style="font-size: 8px;">PROJECT</td> </tr> <tr> <td style="font-size: 8px;">DESIGNED</td> <td style="font-size: 8px;">DRAWN</td> <td style="font-size: 8px;">DATE</td> <td style="font-size: 8px;">CHECKED</td> </tr> <tr> <td style="font-size: 8px;">DW</td> <td style="font-size: 8px;">AD</td> <td style="font-size: 8px;">AS SHOWN</td> <td style="font-size: 8px;">SCALE</td> </tr> <tr> <td style="font-size: 8px;">CAD REF.</td> <td colspan="3" style="font-size: 8px;">E-MAIL</td> </tr> </table>	PROJECT MANAGER	ARCHITECT	CLIENT	PROJECT	DESIGNED	DRAWN	DATE	CHECKED	DW	AD	AS SHOWN	SCALE	CAD REF.	E-MAIL			<table border="1" style="width: 100%; border-collapse: collapse;"> <tr> <td style="font-size: 8px;">PROJECT MANAGER</td> <td style="font-size: 8px;">ARCHITECT</td> <td style="font-size: 8px;">CLIENT</td> <td style="font-size: 8px;">PROJECT</td> </tr> <tr> <td style="font-size: 8px;">DESIGNED</td> <td style="font-size: 8px;">DRAWN</td> <td style="font-size: 8px;">DATE</td> <td style="font-size: 8px;">CHECKED</td> </tr> <tr> <td style="font-size: 8px;">DW</td> <td style="font-size: 8px;">AD</td> <td style="font-size: 8px;">AS SHOWN</td> <td style="font-size: 8px;">SCALE</td> </tr> <tr> <td style="font-size: 8px;">CAD REF.</td> <td colspan="3" style="font-size: 8px;">E-MAIL</td> </tr> </table>	PROJECT MANAGER	ARCHITECT	CLIENT	PROJECT	DESIGNED	DRAWN	DATE	CHECKED	DW	AD	AS SHOWN	SCALE	CAD REF.	E-MAIL			<table border="1" style="width: 100%; border-collapse: collapse;"> <tr> <td style="font-size: 8px;">PROJECT MANAGER</td> <td style="font-size: 8px;">ARCHITECT</td> <td style="font-size: 8px;">CLIENT</td> <td style="font-size: 8px;">PROJECT</td> </tr> <tr> <td style="font-size: 8px;">DESIGNED</td> <td style="font-size: 8px;">DRAWN</td> <td style="font-size: 8px;">DATE</td> <td style="font-size: 8px;">CHECKED</td> </tr> <tr> <td style="font-size: 8px;">DW</td> <td style="font-size: 8px;">AD</td> <td style="font-size: 8px;">AS SHOWN</td> <td style="font-size: 8px;">SCALE</td> </tr> <tr> <td style="font-size: 8px;">CAD REF.</td> <td colspan="3" style="font-size: 8px;">E-MAIL</td> </tr> </table>	PROJECT MANAGER	ARCHITECT	CLIENT	PROJECT	DESIGNED	DRAWN	DATE	CHECKED	DW	AD	AS SHOWN	SCALE	CAD REF.	E-MAIL			<table border="1" style="width: 100%; border-collapse: collapse;"> <tr> <td style="font-size: 8px;">PROJECT MANAGER</td> <td style="font-size: 8px;">ARCHITECT</td> <td style="font-size: 8px;">CLIENT</td> <td style="font-size: 8px;">PROJECT</td> </tr> <tr> <td style="font-size: 8px;">DESIGNED</td> <td style="font-size: 8px;">DRAWN</td> <td style="font-size: 8px;">DATE</td> <td style="font-size: 8px;">CHECKED</td> </tr> <tr> <td style="font-size: 8px;">DW</td> <td style="font-size: 8px;">AD</td> <td style="font-size: 8px;">AS SHOWN</td> <td style="font-size: 8px;">SCALE</td> </tr> <tr> <td style="font-size: 8px;">CAD REF.</td> <td colspan="3" style="font-size: 8px;">E-MAIL</td> </tr> </table>	PROJECT MANAGER	ARCHITECT	CLIENT	PROJECT	DESIGNED	DRAWN	DATE	CHECKED	DW	AD	AS SHOWN	SCALE	CAD REF.	E-MAIL			<table border="1" style="width: 100%; border-collapse: collapse;"> <tr> <td style="font-size: 8px;">PROJECT MANAGER</td> <td style="font-size: 8px;">ARCHITECT</td> <td style="font-size: 8px;">CLIENT</td> <td style="font-size: 8px;">PROJECT</td> </tr> <tr> <td style="font-size: 8px;">DESIGNED</td> <td style="font-size: 8px;">DRAWN</td> <td style="font-size: 8px;">DATE</td> <td style="font-size: 8px;">CHECKED</td> </tr> <tr> <td style="font-size: 8px;">DW</td> <td style="font-size: 8px;">AD</td> <td style="font-size: 8px;">AS SHOWN</td> <td style="font-size: 8px;">SCALE</td> </tr> <tr> <td style="font-size: 8px;">CAD REF.</td> <td colspan="3" style="font-size: 8px;">E-MAIL</td> </tr> </table>	PROJECT MANAGER	ARCHITECT	CLIENT	PROJECT	DESIGNED	DRAWN	DATE	CHECKED	DW	AD	AS SHOWN	SCALE	CAD REF.	E-MAIL			<table border="1" style="width: 100%; border-collapse: collapse;"> <tr> <td style="font-size: 8px;">PROJECT MANAGER</td> <td style="font-size: 8px;">ARCHITECT</td> <td style="font-size: 8px;">CLIENT</td> <td style="font-size: 8px;">PROJECT</td> </tr> <tr> <td style="font-size: 8px;">DESIGNED</td> <td style="font-size: 8px;">DRAWN</td> <td style="font-size: 8px;">DATE</td> <td style="font-size: 8px;">CHECKED</td> </tr> <tr> <td style="font-size: 8px;">DW</td> <td style="font-size: 8px;">AD</td> <td style="font-size: 8px;">AS SHOWN</td> <td style="font-size: 8px;">SCALE</td> </tr> <tr> <td style="font-size: 8px;">CAD REF.</td> <td colspan="3" style="font-size: 8px;">E-MAIL</td> </tr> </table>	PROJECT MANAGER	ARCHITECT	CLIENT	PROJECT	DESIGNED	DRAWN	DATE	CHECKED	DW	AD	AS SHOWN	SCALE	CAD REF.	E-MAIL			<table border="1" style="width: 100%; border-collapse: collapse;"> <tr> <td style="font-size: 8px;">PROJECT MANAGER</td> <td style="font-size: 8px;">ARCHITECT</td> <td style="font-size: 8px;">CLIENT</td> <td style="font-size: 8px;">PROJECT</td> </tr> <tr> <td style="font-size: 8px;">DESIGNED</td> <td style="font-size: 8px;">DRAWN</td> <td style="font-size: 8px;">DATE</td> <td style="font-size: 8px;">CHECKED</td> </tr> <tr> <td style="font-size: 8px;">DW</td> <td style="font-size: 8px;">AD</td> <td style="font-size: 8px;">AS SHOWN</td> <td style="font-size: 8px;">SCALE</td> </tr> <tr> <td style="font-size: 8px;">CAD REF.</td> <td colspan="3" style="font-size: 8px;">E-MAIL</td> </tr> </table>	PROJECT MANAGER	ARCHITECT	CLIENT	PROJECT	DESIGNED	DRAWN	DATE	CHECKED	DW	AD	AS SHOWN	SCALE	CAD REF.	E-MAIL			<table border="1" style="width: 100%; border-collapse: collapse;"> <tr> <td style="font-size: 8px;">PROJECT MANAGER</td> <td style="font-size: 8px;">ARCHITECT</td> <td style="font-size: 8px;">CLIENT</td> <td style="font-size: 8px;">PROJECT</td> </tr> <tr> <td style="font-size: 8px;">DESIGNED</td> <td style="font-size: 8px;">DRAWN</td> <td style="font-size: 8px;">DATE</td> <td style="font-size: 8px;">CHECKED</td> </tr> <tr> <td style="font-size: 8px;">DW</td> <td style="font-size: 8px;">AD</td> <td style="font-size: 8px;">AS SHOWN</td> <td style="font-size: 8px;">SCALE</td> </tr> <tr> <td style="font-size: 8px;">CAD REF.</td> <td colspan="3" style="font-size: 8px;">E-MAIL</td> </tr> </table>	PROJECT MANAGER	ARCHITECT	CLIENT	PROJECT	DESIGNED	DRAWN	DATE	CHECKED	DW	AD	AS SHOWN	SCALE	CAD REF.	E-MAIL			<table border="1" style="width: 100%; border-collapse: collapse;"> <tr> <td style="font-size: 8px;">PROJECT MANAGER</td> <td style="font-size: 8px;">ARCHITECT</td> <td style="font-size: 8px;">CLIENT</td> <td style="font-size: 8px;">PROJECT</td> </tr> <tr> <td style="font-size: 8px;">DESIGNED</td> <td style="font-size: 8px;">DRAWN</td> <td style="font-size: 8px;">DATE</td> <td style="font-size: 8px;">CHECKED</td> </tr> <tr> <td style="font-size: 8px;">DW</td> <td style="font-size: 8px;">AD</td> <td style="font-size: 8px;">AS SHOWN</td> <td style="font-size: 8px;">SCALE</td> </tr> <tr> <td style="font-size: 8px;">CAD REF.</td> <td colspan="3" style="font-size: 8px;">E-MAIL</td> </tr> </table>	PROJECT MANAGER	ARCHITECT	CLIENT	PROJECT	DESIGNED	DRAWN	DATE	CHECKED	DW	AD	AS SHOWN	SCALE	CAD REF.	E-MAIL			<table border="1" style="width: 100%; border-collapse: collapse;"> <tr> <td style="font-size: 8px;">PROJECT MANAGER</td> <td style="font-size: 8px;">ARCHITECT</td> <td style="font-size: 8px;">CLIENT</td> <td style="font-size: 8px;">PROJECT</td> </tr> <tr> <td style="font-size: 8px;">DESIGNED</td> <td style="font-size: 8px;">DRAWN</td> <td style="font-size: 8px;">DATE</td> <td style="font-size: 8px;">CHECKED</td> </tr> <tr> <td style="font-size: 8px;">DW</td> <td style="font-size: 8px;">AD</td> <td style="font-size: 8px;">AS SHOWN</td> <td style="font-size: 8px;">SCALE</td> </tr> <tr> <td style="font-size: 8px;">CAD REF.</td> <td colspan="3" style="font-size: 8px;">E-MAIL</td> </tr> </table>	PROJECT MANAGER	ARCHITECT	CLIENT	PROJECT	DESIGNED	DRAWN	DATE	CHECKED	DW	AD	AS SHOWN	SCALE	CAD REF.	E-MAIL			<table border="1" style="width: 100%; border-collapse: collapse;"> <tr> <td style="font-size: 8px;">PROJECT MANAGER</td> <td style="font-size: 8px;">ARCHITECT</td> <td style="font-size: 8px;">CLIENT</td> <td style="font-size: 8px;">PROJECT</td> </tr> <tr> <td style="font-size: 8px;">DESIGNED</td> <td style="font-size: 8px;">DRAWN</td> <td style="font-size: 8px;">DATE</td> <td style="font-size: 8px;">CHECKED</td> </tr> <tr> <td style="font-size: 8px;">DW</td> <td style="font-size: 8px;">AD</td> <td style="font-size: 8px;">AS SHOWN</td> <td style="font-size: 8px;">SCALE</td> </tr> <tr> <td style="font-size: 8px;">CAD REF.</td> <td colspan="3" style="font-size: 8px;">E-MAIL</td> </tr> </table>	PROJECT MANAGER	ARCHITECT	CLIENT	PROJECT	DESIGNED	DRAWN	DATE	CHECKED	DW	AD	AS SHOWN	SCALE	CAD REF.	E-MAIL			<table border="1" style="width: 100%; border-collapse: collapse;"> <tr> <td style="font-size: 8px;">PROJECT MANAGER</td> <td style="font-size: 8px;">ARCHITECT</td> <td style="font-size: 8px;">CLIENT</td> <td style="font-size: 8px;">PROJECT</td> </tr> <tr> <td style="font-size: 8px;">DESIGNED</td> <td style="font-size: 8px;">DRAWN</td> <td style="font-size: 8px;">DATE</td> <td style="font-size: 8px;">CHECKED</td> </tr> <tr> <td style="font-size: 8px;">DW</td> <td style="font-size: 8px;">AD</td> <td style="font-size: 8px;">AS SHOWN</td> <td style="font-size: 8px;">SCALE</td> </tr> <tr> <td style="font-size: 8px;">CAD REF.</td> <td colspan="3" style="font-size: 8px;">E-MAIL</td> </tr> </table>	PROJECT MANAGER	ARCHITECT	CLIENT	PROJECT	DESIGNED	DRAWN	DATE	CHECKED	DW	AD	AS SHOWN	SCALE	CAD REF.	E-MAIL			<table border="1" style="width: 100%; border-collapse: collapse;"> <tr> <td style="font-size: 8px;">PROJECT MANAGER</td> <td style="font-size: 8px;">ARCHITECT</td> <td style="font-size: 8px;">CLIENT</td> <td style="font-size: 8px;">PROJECT</td> </tr> <tr> <td style="font-size: 8px;">DESIGNED</td> <td style="font-size: 8px;">DRAWN</td> <td style="font-size: 8px;">DATE</td> <td style="font-size: 8px;">CHECKED</td> </tr> <tr> <td style="font-size: 8px;">DW</td> <td style="font-size: 8px;">AD</td> <td style="font-size: 8px;">AS SHOWN</td> <td style="font-size: 8px;">SCALE</td> </tr> <tr> <td style="font-size: 8px;">CAD REF.</td> <td colspan="3" style="font-size: 8px;">E-MAIL</td> </tr> </table>	PROJECT MANAGER	ARCHITECT	CLIENT	PROJECT	DESIGNED	DRAWN	DATE	CHECKED	DW	AD	AS SHOWN	SCALE	CAD REF.	E-MAIL			<table border="1" style="width: 100%; border-collapse: collapse;"> <tr> <td style="font-size: 8px;">PROJECT MANAGER</td> <td style="font-size: 8px;">ARCHITECT</td> <td style="font-size: 8px;">CLIENT</td> <td style="font-size: 8px;">PROJECT</td> </tr> <tr> <td style="font-size: 8px;">DESIGNED</td> <td style="font-size: 8px;">DRAWN</td> <td style="font-size: 8px;">DATE</td> <td style="font-size: 8px;">CHECKED</td> </tr> <tr> </tr></table>	PROJECT MANAGER	ARCHITECT	CLIENT	PROJECT	DESIGNED	DRAWN	DATE	CHECKED
ISSUED FOR SWC-3	21.02.25	2																																																																																																																																																																																																																																																																																																																																																																																																																																																																																																																																																																																																																																																										
ISSUED FOR CONSTRUCTION	24.07.24	1																																																																																																																																																																																																																																																																																																																																																																																																																																																																																																																																																																																																																																																										
ISSUED FOR CONSTRUCTION	02.05.24	0																																																																																																																																																																																																																																																																																																																																																																																																																																																																																																																																																																																																																																																										
ISSUED FOR PRELIMINARY ONLY	15.03.24	A																																																																																																																																																																																																																																																																																																																																																																																																																																																																																																																																																																																																																																																										
AMENDMENTS	DATE	ISSUE																																																																																																																																																																																																																																																																																																																																																																																																																																																																																																																																																																																																																																																										
PROJECT MANAGER	ARCHITECT	CLIENT	PROJECT																																																																																																																																																																																																																																																																																																																																																																																																																																																																																																																																																																																																																																																									
DESIGNED	DRAWN	DATE	CHECKED																																																																																																																																																																																																																																																																																																																																																																																																																																																																																																																																																																																																																																																									
DW	AD	AS SHOWN	SCALE																																																																																																																																																																																																																																																																																																																																																																																																																																																																																																																																																																																																																																																									
CAD REF.	E-MAIL																																																																																																																																																																																																																																																																																																																																																																																																																																																																																																																																																																																																																																																											
PROJECT MANAGER	ARCHITECT	CLIENT	PROJECT																																																																																																																																																																																																																																																																																																																																																																																																																																																																																																																																																																																																																																																									
DESIGNED	DRAWN	DATE	CHECKED																																																																																																																																																																																																																																																																																																																																																																																																																																																																																																																																																																																																																																																									
DW	AD	AS SHOWN	SCALE																																																																																																																																																																																																																																																																																																																																																																																																																																																																																																																																																																																																																																																									
CAD REF.	E-MAIL																																																																																																																																																																																																																																																																																																																																																																																																																																																																																																																																																																																																																																																											
PROJECT MANAGER	ARCHITECT	CLIENT	PROJECT																																																																																																																																																																																																																																																																																																																																																																																																																																																																																																																																																																																																																																																									
DESIGNED	DRAWN	DATE	CHECKED																																																																																																																																																																																																																																																																																																																																																																																																																																																																																																																																																																																																																																																									
DW	AD	AS SHOWN	SCALE																																																																																																																																																																																																																																																																																																																																																																																																																																																																																																																																																																																																																																																									
CAD REF.	E-MAIL																																																																																																																																																																																																																																																																																																																																																																																																																																																																																																																																																																																																																																																											
PROJECT MANAGER	ARCHITECT	CLIENT	PROJECT																																																																																																																																																																																																																																																																																																																																																																																																																																																																																																																																																																																																																																																									
DESIGNED	DRAWN	DATE	CHECKED																																																																																																																																																																																																																																																																																																																																																																																																																																																																																																																																																																																																																																																									
DW	AD	AS SHOWN	SCALE																																																																																																																																																																																																																																																																																																																																																																																																																																																																																																																																																																																																																																																									
CAD REF.	E-MAIL																																																																																																																																																																																																																																																																																																																																																																																																																																																																																																																																																																																																																																																											
PROJECT MANAGER	ARCHITECT	CLIENT	PROJECT																																																																																																																																																																																																																																																																																																																																																																																																																																																																																																																																																																																																																																																									
DESIGNED	DRAWN	DATE	CHECKED																																																																																																																																																																																																																																																																																																																																																																																																																																																																																																																																																																																																																																																									
DW	AD	AS SHOWN	SCALE																																																																																																																																																																																																																																																																																																																																																																																																																																																																																																																																																																																																																																																									
CAD REF.	E-MAIL																																																																																																																																																																																																																																																																																																																																																																																																																																																																																																																																																																																																																																																											
PROJECT MANAGER	ARCHITECT	CLIENT	PROJECT																																																																																																																																																																																																																																																																																																																																																																																																																																																																																																																																																																																																																																																									
DESIGNED	DRAWN	DATE	CHECKED																																																																																																																																																																																																																																																																																																																																																																																																																																																																																																																																																																																																																																																									
DW	AD	AS SHOWN	SCALE																																																																																																																																																																																																																																																																																																																																																																																																																																																																																																																																																																																																																																																									
CAD REF.	E-MAIL																																																																																																																																																																																																																																																																																																																																																																																																																																																																																																																																																																																																																																																											
PROJECT MANAGER	ARCHITECT	CLIENT	PROJECT																																																																																																																																																																																																																																																																																																																																																																																																																																																																																																																																																																																																																																																									
DESIGNED	DRAWN	DATE	CHECKED																																																																																																																																																																																																																																																																																																																																																																																																																																																																																																																																																																																																																																																									
DW	AD	AS SHOWN	SCALE																																																																																																																																																																																																																																																																																																																																																																																																																																																																																																																																																																																																																																																									
CAD REF.	E-MAIL																																																																																																																																																																																																																																																																																																																																																																																																																																																																																																																																																																																																																																																											
PROJECT MANAGER	ARCHITECT	CLIENT	PROJECT																																																																																																																																																																																																																																																																																																																																																																																																																																																																																																																																																																																																																																																									
DESIGNED	DRAWN	DATE	CHECKED																																																																																																																																																																																																																																																																																																																																																																																																																																																																																																																																																																																																																																																									
DW	AD	AS SHOWN	SCALE																																																																																																																																																																																																																																																																																																																																																																																																																																																																																																																																																																																																																																																									
CAD REF.	E-MAIL																																																																																																																																																																																																																																																																																																																																																																																																																																																																																																																																																																																																																																																											
PROJECT MANAGER	ARCHITECT	CLIENT	PROJECT																																																																																																																																																																																																																																																																																																																																																																																																																																																																																																																																																																																																																																																									
DESIGNED	DRAWN	DATE	CHECKED																																																																																																																																																																																																																																																																																																																																																																																																																																																																																																																																																																																																																																																									
DW	AD	AS SHOWN	SCALE																																																																																																																																																																																																																																																																																																																																																																																																																																																																																																																																																																																																																																																									
CAD REF.	E-MAIL																																																																																																																																																																																																																																																																																																																																																																																																																																																																																																																																																																																																																																																											
PROJECT MANAGER	ARCHITECT	CLIENT	PROJECT																																																																																																																																																																																																																																																																																																																																																																																																																																																																																																																																																																																																																																																									
DESIGNED	DRAWN	DATE	CHECKED																																																																																																																																																																																																																																																																																																																																																																																																																																																																																																																																																																																																																																																									
DW	AD	AS SHOWN	SCALE																																																																																																																																																																																																																																																																																																																																																																																																																																																																																																																																																																																																																																																									
CAD REF.	E-MAIL																																																																																																																																																																																																																																																																																																																																																																																																																																																																																																																																																																																																																																																											
PROJECT MANAGER	ARCHITECT	CLIENT	PROJECT																																																																																																																																																																																																																																																																																																																																																																																																																																																																																																																																																																																																																																																									
DESIGNED	DRAWN	DATE	CHECKED																																																																																																																																																																																																																																																																																																																																																																																																																																																																																																																																																																																																																																																									
DW	AD	AS SHOWN	SCALE																																																																																																																																																																																																																																																																																																																																																																																																																																																																																																																																																																																																																																																									
CAD REF.	E-MAIL																																																																																																																																																																																																																																																																																																																																																																																																																																																																																																																																																																																																																																																											
PROJECT MANAGER	ARCHITECT	CLIENT	PROJECT																																																																																																																																																																																																																																																																																																																																																																																																																																																																																																																																																																																																																																																									
DESIGNED	DRAWN	DATE	CHECKED																																																																																																																																																																																																																																																																																																																																																																																																																																																																																																																																																																																																																																																									
DW	AD	AS SHOWN	SCALE																																																																																																																																																																																																																																																																																																																																																																																																																																																																																																																																																																																																																																																									
CAD REF.	E-MAIL																																																																																																																																																																																																																																																																																																																																																																																																																																																																																																																																																																																																																																																											
PROJECT MANAGER	ARCHITECT	CLIENT	PROJECT																																																																																																																																																																																																																																																																																																																																																																																																																																																																																																																																																																																																																																																									
DESIGNED	DRAWN	DATE	CHECKED																																																																																																																																																																																																																																																																																																																																																																																																																																																																																																																																																																																																																																																									
DW	AD	AS SHOWN	SCALE																																																																																																																																																																																																																																																																																																																																																																																																																																																																																																																																																																																																																																																									
CAD REF.	E-MAIL																																																																																																																																																																																																																																																																																																																																																																																																																																																																																																																																																																																																																																																											
PROJECT MANAGER	ARCHITECT	CLIENT	PROJECT																																																																																																																																																																																																																																																																																																																																																																																																																																																																																																																																																																																																																																																									
DESIGNED	DRAWN	DATE	CHECKED																																																																																																																																																																																																																																																																																																																																																																																																																																																																																																																																																																																																																																																									
DW	AD	AS SHOWN	SCALE																																																																																																																																																																																																																																																																																																																																																																																																																																																																																																																																																																																																																																																									
CAD REF.	E-MAIL																																																																																																																																																																																																																																																																																																																																																																																																																																																																																																																																																																																																																																																											
PROJECT MANAGER	ARCHITECT	CLIENT	PROJECT																																																																																																																																																																																																																																																																																																																																																																																																																																																																																																																																																																																																																																																									
DESIGNED	DRAWN	DATE	CHECKED																																																																																																																																																																																																																																																																																																																																																																																																																																																																																																																																																																																																																																																									
DW	AD	AS SHOWN	SCALE																																																																																																																																																																																																																																																																																																																																																																																																																																																																																																																																																																																																																																																									
CAD REF.	E-MAIL																																																																																																																																																																																																																																																																																																																																																																																																																																																																																																																																																																																																																																																											
PROJECT MANAGER	ARCHITECT	CLIENT	PROJECT																																																																																																																																																																																																																																																																																																																																																																																																																																																																																																																																																																																																																																																									
DESIGNED	DRAWN	DATE	CHECKED																																																																																																																																																																																																																																																																																																																																																																																																																																																																																																																																																																																																																																																									
DW	AD	AS SHOWN	SCALE																																																																																																																																																																																																																																																																																																																																																																																																																																																																																																																																																																																																																																																									
CAD REF.	E-MAIL																																																																																																																																																																																																																																																																																																																																																																																																																																																																																																																																																																																																																																																											
PROJECT MANAGER	ARCHITECT	CLIENT	PROJECT																																																																																																																																																																																																																																																																																																																																																																																																																																																																																																																																																																																																																																																									
DESIGNED	DRAWN	DATE	CHECKED																																																																																																																																																																																																																																																																																																																																																																																																																																																																																																																																																																																																																																																									
DW	AD	AS SHOWN	SCALE																																																																																																																																																																																																																																																																																																																																																																																																																																																																																																																																																																																																																																																									
CAD REF.	E-MAIL																																																																																																																																																																																																																																																																																																																																																																																																																																																																																																																																																																																																																																																											
PROJECT MANAGER	ARCHITECT	CLIENT	PROJECT																																																																																																																																																																																																																																																																																																																																																																																																																																																																																																																																																																																																																																																									
DESIGNED	DRAWN	DATE	CHECKED																																																																																																																																																																																																																																																																																																																																																																																																																																																																																																																																																																																																																																																									
DW	AD	AS SHOWN	SCALE																																																																																																																																																																																																																																																																																																																																																																																																																																																																																																																																																																																																																																																									
CAD REF.	E-MAIL																																																																																																																																																																																																																																																																																																																																																																																																																																																																																																																																																																																																																																																											
PROJECT MANAGER	ARCHITECT	CLIENT	PROJECT																																																																																																																																																																																																																																																																																																																																																																																																																																																																																																																																																																																																																																																									
DESIGNED	DRAWN	DATE	CHECKED																																																																																																																																																																																																																																																																																																																																																																																																																																																																																																																																																																																																																																																									
DW	AD	AS SHOWN	SCALE																																																																																																																																																																																																																																																																																																																																																																																																																																																																																																																																																																																																																																																									
CAD REF.	E-MAIL																																																																																																																																																																																																																																																																																																																																																																																																																																																																																																																																																																																																																																																											
PROJECT MANAGER	ARCHITECT	CLIENT	PROJECT																																																																																																																																																																																																																																																																																																																																																																																																																																																																																																																																																																																																																																																									
DESIGNED	DRAWN	DATE	CHECKED																																																																																																																																																																																																																																																																																																																																																																																																																																																																																																																																																																																																																																																									
DW	AD	AS SHOWN	SCALE																																																																																																																																																																																																																																																																																																																																																																																																																																																																																																																																																																																																																																																									
CAD REF.	E-MAIL																																																																																																																																																																																																																																																																																																																																																																																																																																																																																																																																																																																																																																																											
PROJECT MANAGER	ARCHITECT	CLIENT	PROJECT																																																																																																																																																																																																																																																																																																																																																																																																																																																																																																																																																																																																																																																									
DESIGNED	DRAWN	DATE	CHECKED																																																																																																																																																																																																																																																																																																																																																																																																																																																																																																																																																																																																																																																									
DW	AD	AS SHOWN	SCALE																																																																																																																																																																																																																																																																																																																																																																																																																																																																																																																																																																																																																																																									
CAD REF.	E-MAIL																																																																																																																																																																																																																																																																																																																																																																																																																																																																																																																																																																																																																																																											
PROJECT MANAGER	ARCHITECT	CLIENT	PROJECT																																																																																																																																																																																																																																																																																																																																																																																																																																																																																																																																																																																																																																																									
DESIGNED	DRAWN	DATE	CHECKED																																																																																																																																																																																																																																																																																																																																																																																																																																																																																																																																																																																																																																																									
DW	AD	AS SHOWN	SCALE																																																																																																																																																																																																																																																																																																																																																																																																																																																																																																																																																																																																																																																									
CAD REF.	E-MAIL																																																																																																																																																																																																																																																																																																																																																																																																																																																																																																																																																																																																																																																											
PROJECT MANAGER	ARCHITECT	CLIENT	PROJECT																																																																																																																																																																																																																																																																																																																																																																																																																																																																																																																																																																																																																																																									
DESIGNED	DRAWN	DATE	CHECKED																																																																																																																																																																																																																																																																																																																																																																																																																																																																																																																																																																																																																																																									
DW	AD	AS SHOWN	SCALE																																																																																																																																																																																																																																																																																																																																																																																																																																																																																																																																																																																																																																																									
CAD REF.	E-MAIL																																																																																																																																																																																																																																																																																																																																																																																																																																																																																																																																																																																																																																																											
PROJECT MANAGER	ARCHITECT	CLIENT	PROJECT																																																																																																																																																																																																																																																																																																																																																																																																																																																																																																																																																																																																																																																									
DESIGNED	DRAWN	DATE	CHECKED																																																																																																																																																																																																																																																																																																																																																																																																																																																																																																																																																																																																																																																									
DW	AD	AS SHOWN	SCALE																																																																																																																																																																																																																																																																																																																																																																																																																																																																																																																																																																																																																																																									
CAD REF.	E-MAIL																																																																																																																																																																																																																																																																																																																																																																																																																																																																																																																																																																																																																																																											
PROJECT MANAGER	ARCHITECT	CLIENT	PROJECT																																																																																																																																																																																																																																																																																																																																																																																																																																																																																																																																																																																																																																																									
DESIGNED	DRAWN	DATE	CHECKED																																																																																																																																																																																																																																																																																																																																																																																																																																																																																																																																																																																																																																																									
DW	AD	AS SHOWN	SCALE																																																																																																																																																																																																																																																																																																																																																																																																																																																																																																																																																																																																																																																									
CAD REF.	E-MAIL																																																																																																																																																																																																																																																																																																																																																																																																																																																																																																																																																																																																																																																											
PROJECT MANAGER	ARCHITECT	CLIENT	PROJECT																																																																																																																																																																																																																																																																																																																																																																																																																																																																																																																																																																																																																																																									
DESIGNED	DRAWN	DATE	CHECKED																																																																																																																																																																																																																																																																																																																																																																																																																																																																																																																																																																																																																																																									
DW	AD	AS SHOWN	SCALE																																																																																																																																																																																																																																																																																																																																																																																																																																																																																																																																																																																																																																																									
CAD REF.	E-MAIL																																																																																																																																																																																																																																																																																																																																																																																																																																																																																																																																																																																																																																																											
PROJECT MANAGER	ARCHITECT	CLIENT	PROJECT																																																																																																																																																																																																																																																																																																																																																																																																																																																																																																																																																																																																																																																									
DESIGNED	DRAWN	DATE	CHECKED																																																																																																																																																																																																																																																																																																																																																																																																																																																																																																																																																																																																																																																									
DW	AD	AS SHOWN	SCALE																																																																																																																																																																																																																																																																																																																																																																																																																																																																																																																																																																																																																																																									
CAD REF.	E-MAIL																																																																																																																																																																																																																																																																																																																																																																																																																																																																																																																																																																																																																																																											
PROJECT MANAGER	ARCHITECT	CLIENT	PROJECT																																																																																																																																																																																																																																																																																																																																																																																																																																																																																																																																																																																																																																																									
DESIGNED	DRAWN	DATE	CHECKED																																																																																																																																																																																																																																																																																																																																																																																																																																																																																																																																																																																																																																																									
DW	AD	AS SHOWN	SCALE																																																																																																																																																																																																																																																																																																																																																																																																																																																																																																																																																																																																																																																									
CAD REF.	E-MAIL																																																																																																																																																																																																																																																																																																																																																																																																																																																																																																																																																																																																																																																											
PROJECT MANAGER	ARCHITECT	CLIENT	PROJECT																																																																																																																																																																																																																																																																																																																																																																																																																																																																																																																																																																																																																																																									
DESIGNED	DRAWN	DATE	CHECKED																																																																																																																																																																																																																																																																																																																																																																																																																																																																																																																																																																																																																																																									
DW	AD	AS SHOWN	SCALE																																																																																																																																																																																																																																																																																																																																																																																																																																																																																																																																																																																																																																																									
CAD REF.	E-MAIL																																																																																																																																																																																																																																																																																																																																																																																																																																																																																																																																																																																																																																																											
PROJECT MANAGER	ARCHITECT	CLIENT	PROJECT																																																																																																																																																																																																																																																																																																																																																																																																																																																																																																																																																																																																																																																									
DESIGNED	DRAWN	DATE	CHECKED																																																																																																																																																																																																																																																																																																																																																																																																																																																																																																																																																																																																																																																									
DW	AD	AS SHOWN	SCALE																																																																																																																																																																																																																																																																																																																																																																																																																																																																																																																																																																																																																																																									
CAD REF.	E-MAIL																																																																																																																																																																																																																																																																																																																																																																																																																																																																																																																																																																																																																																																											
PROJECT MANAGER	ARCHITECT	CLIENT	PROJECT																																																																																																																																																																																																																																																																																																																																																																																																																																																																																																																																																																																																																																																									
DESIGNED	DRAWN	DATE	CHECKED																																																																																																																																																																																																																																																																																																																																																																																																																																																																																																																																																																																																																																																									
DW	AD	AS SHOWN	SCALE																																																																																																																																																																																																																																																																																																																																																																																																																																																																																																																																																																																																																																																									
CAD REF.	E-MAIL																																																																																																																																																																																																																																																																																																																																																																																																																																																																																																																																																																																																																																																											
PROJECT MANAGER	ARCHITECT	CLIENT	PROJECT																																																																																																																																																																																																																																																																																																																																																																																																																																																																																																																																																																																																																																																									
DESIGNED	DRAWN	DATE	CHECKED																																																																																																																																																																																																																																																																																																																																																																																																																																																																																																																																																																																																																																																									
DW	AD	AS SHOWN	SCALE																																																																																																																																																																																																																																																																																																																																																																																																																																																																																																																																																																																																																																																									
CAD REF.	E-MAIL																																																																																																																																																																																																																																																																																																																																																																																																																																																																																																																																																																																																																																																											
PROJECT MANAGER	ARCHITECT	CLIENT	PROJECT																																																																																																																																																																																																																																																																																																																																																																																																																																																																																																																																																																																																																																																									
DESIGNED	DRAWN	DATE	CHECKED																																																																																																																																																																																																																																																																																																																																																																																																																																																																																																																																																																																																																																																									
DW	AD	AS SHOWN	SCALE																																																																																																																																																																																																																																																																																																																																																																																																																																																																																																																																																																																																																																																									
CAD REF.	E-MAIL																																																																																																																																																																																																																																																																																																																																																																																																																																																																																																																																																																																																																																																											
PROJECT MANAGER	ARCHITECT	CLIENT	PROJECT																																																																																																																																																																																																																																																																																																																																																																																																																																																																																																																																																																																																																																																									
DESIGNED	DRAWN	DATE	CHECKED																																																																																																																																																																																																																																																																																																																																																																																																																																																																																																																																																																																																																																																									
DW	AD	AS SHOWN	SCALE																																																																																																																																																																																																																																																																																																																																																																																																																																																																																																																																																																																																																																																									
CAD REF.	E-MAIL																																																																																																																																																																																																																																																																																																																																																																																																																																																																																																																																																																																																																																																											
PROJECT MANAGER	ARCHITECT	CLIENT	PROJECT																																																																																																																																																																																																																																																																																																																																																																																																																																																																																																																																																																																																																																																									
DESIGNED	DRAWN	DATE	CHECKED																																																																																																																																																																																																																																																																																																																																																																																																																																																																																																																																																																																																																																																									
DW	AD	AS SHOWN	SCALE																																																																																																																																																																																																																																																																																																																																																																																																																																																																																																																																																																																																																																																									
CAD REF.	E-MAIL																																																																																																																																																																																																																																																																																																																																																																																																																																																																																																																																																																																																																																																											
PROJECT MANAGER	ARCHITECT	CLIENT	PROJECT																																																																																																																																																																																																																																																																																																																																																																																																																																																																																																																																																																																																																																																									
DESIGNED	DRAWN	DATE	CHECKED																																																																																																																																																																																																																																																																																																																																																																																																																																																																																																																																																																																																																																																									
DW	AD	AS SHOWN	SCALE																																																																																																																																																																																																																																																																																																																																																																																																																																																																																																																																																																																																																																																									
CAD REF.	E-MAIL																																																																																																																																																																																																																																																																																																																																																																																																																																																																																																																																																																																																																																																											
PROJECT MANAGER	ARCHITECT	CLIENT	PROJECT																																																																																																																																																																																																																																																																																																																																																																																																																																																																																																																																																																																																																																																									
DESIGNED	DRAWN	DATE	CHECKED																																																																																																																																																																																																																																																																																																																																																																																																																																																																																																																																																																																																																																																									

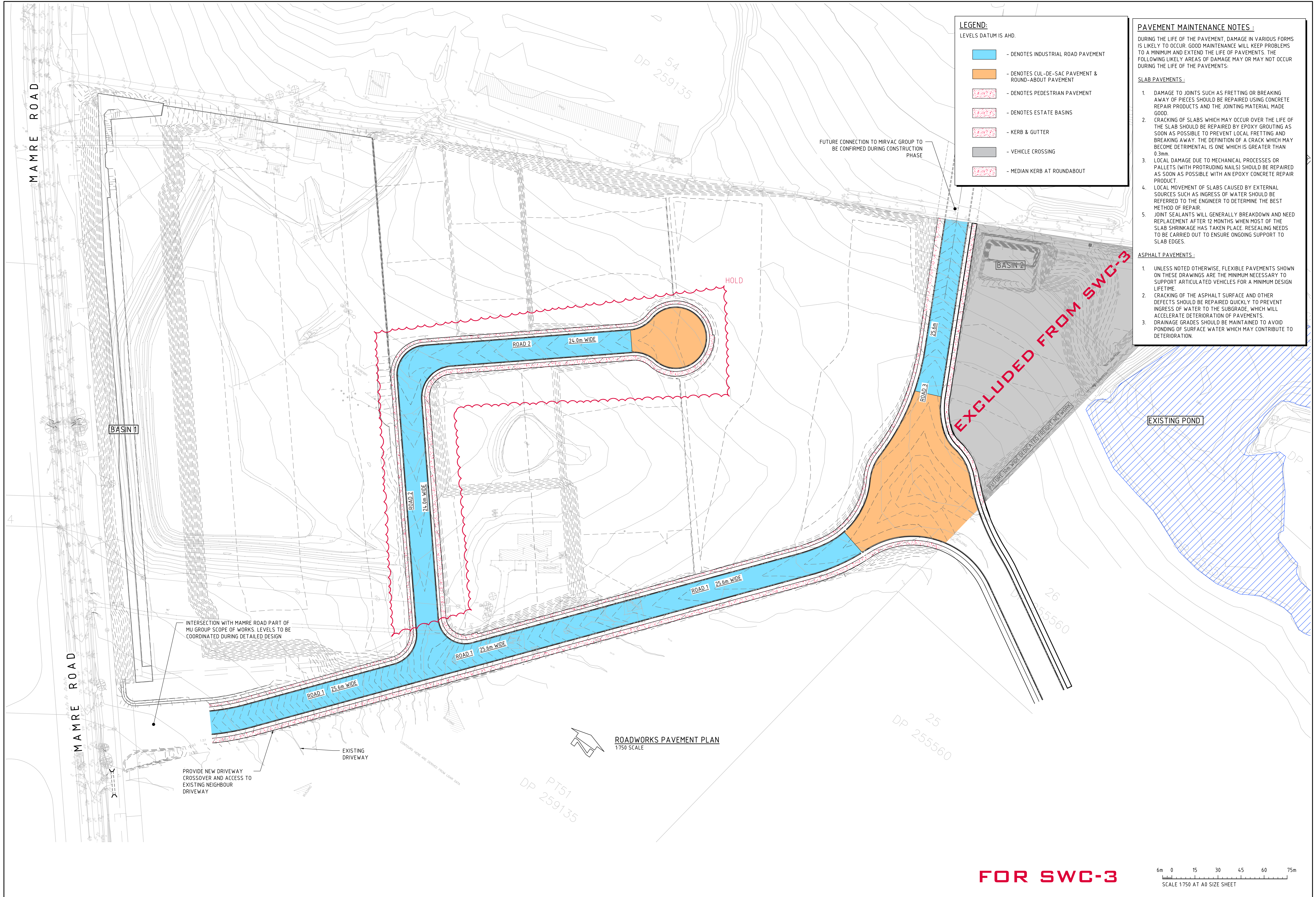

ROADWORKS PAVEMENT PLAN
1:750 SCALE

FOR SWC-3

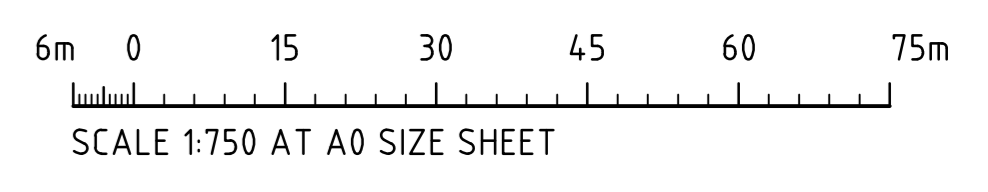

ISSUED FOR SWC-3	21.02.25	2
ISSUED FOR CONSTRUCTION	23.07.24	1
ISSUED FOR CONSTRUCTION	02.05.24	0
REVISED AS ELUCIDED	09.04.24	B
ISSUED FOR PRELIMINARY ONLY	15.03.24	A
AMENDMENTS	DATE	ISSUE

PROJECT MANAGER	ARCHITECT	CLIENT
DESIGNED	DRAWN	DATE
CHECKED	SCALE	AS SHOWN
CAD REF.	C01402105-C 510	

PROJECT MANAGER
ProjectStrategy

ARCHITECT
nettleton|tbe

CLIENT
BURTON
Civil Engineering Contractors

PROJECT
ACCESS LOGISTICS PARK
884-928 MAMRE ROAD
KEMPS CREEK, NSW

CONSULT AUSTRALIA

Costin Roe Consulting Pty Ltd.
ABN 50 003 696 446
PO Box 7419 Sydney NSW 1220
Level 4, 4 Windmill Street, Mollies Point NSW 2000
p: +61 2 9251 7699 f: +61 2 9241 3731
e: mail@costinroe.com.au w: costinroe.com.au

CRC
COSTIN ROE CONSULTING
CIVIL & STRUCTURAL ENGINEERS

DRAWING TITLE
ROADWORKS PAVEMENT PLAN
DRAWING No: **C01402105-C 510** ISSUE **2**

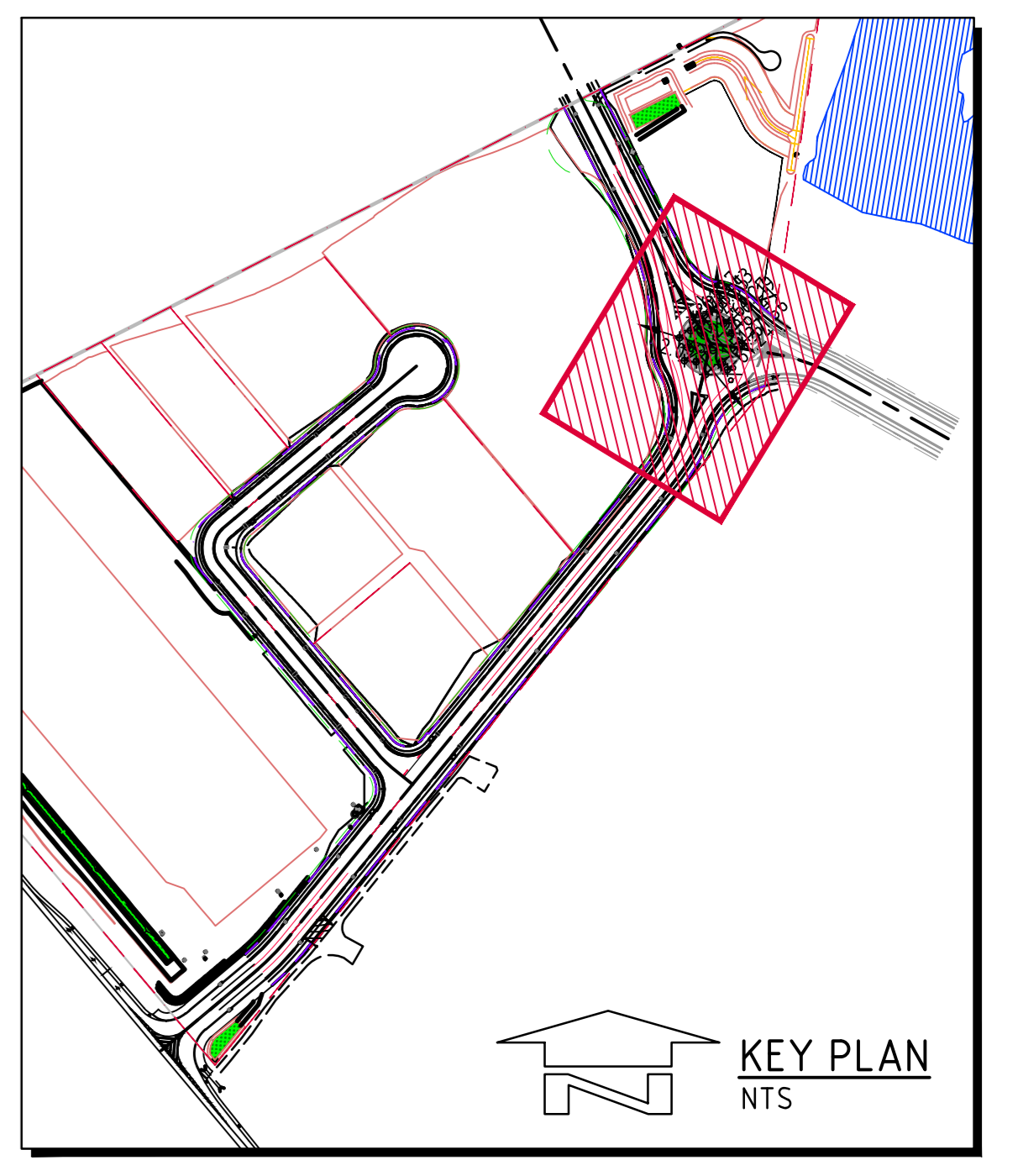
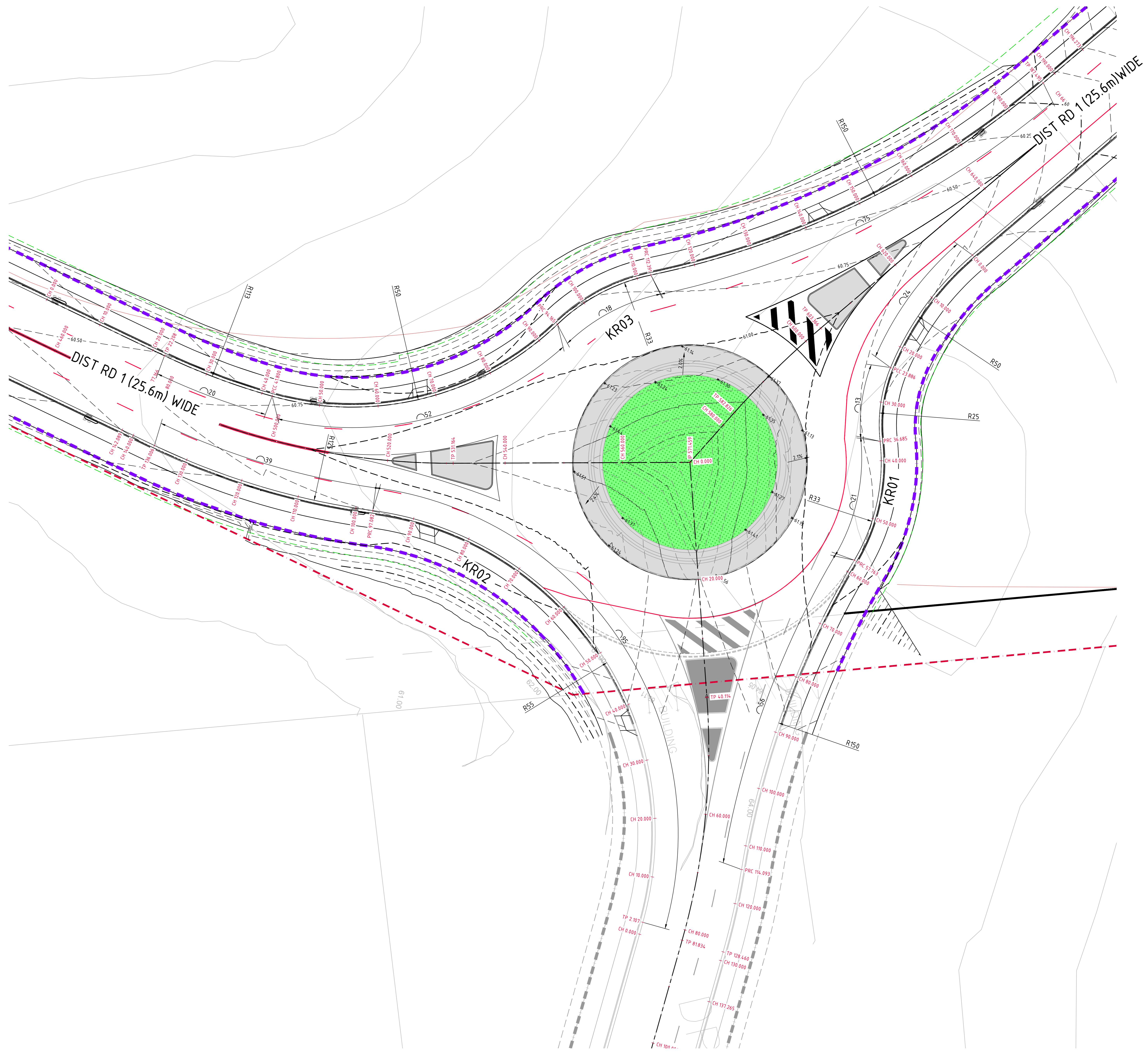

ROAD 1 & 3 ROUNDABOUT PLAN
SCALE 1:250

NOTES:
REFER TO DRAWING C543 & C544 FOR LONGITUDINAL SECTIONS.

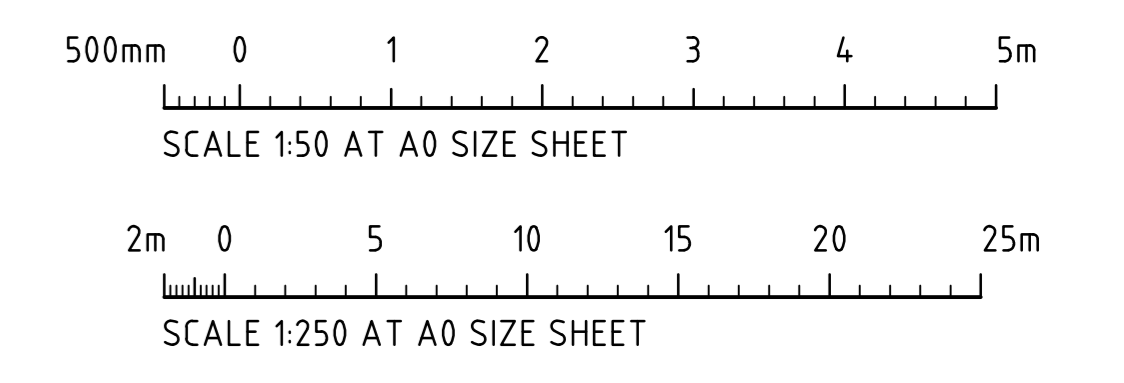

FOR SWC-3

AMENDMENTS	DATE	ISSUE	AMENDMENTS	DATE	ISSUE
ISSUED FOR SWC-3	21.02.25	2			
ISSUED FOR CONSTRUCTION	24.07.24	1			
ISSUED FOR CONSTRUCTION	02.05.24	0			

PROJECT MANAGER	ARCHITECT	CLIENT	PROJECT
ProjectStrategy	nettleton tibe	BURTON Civil Engineering Contractors	ACCESS LOGISTICS PARK 884-928 MAMRE ROAD KEMPS CREEK, NSW

DESIGNED	DRAWN	DATE	CHECKED	SCALE	CAD REF.
DW	MW	AS SHOWN	AS SHOWN	AS SHOWN	C01402105-C542

Costin Roe Consulting Pty Ltd.
 AIN 50 003 696 446
 PO Box 7419, Sydney NSW 1220
 Levels 4 & 5 Woodmill Street, Malletts Point NSW 2000
 p: +61 2 9251 7699 f: +61 2 9241 3731
 e: mail@costinroe.com.au w: costinroe.com.au

CRC
COSTIN ROE CONSULTING
CIVIL & STRUCTURAL ENGINEERS

DRAWING TITLE	DRAWING No	ISSUE
KERB RETURN PLAN DIST RD 1 ROUNDABOUT	C014021.05-C542	2

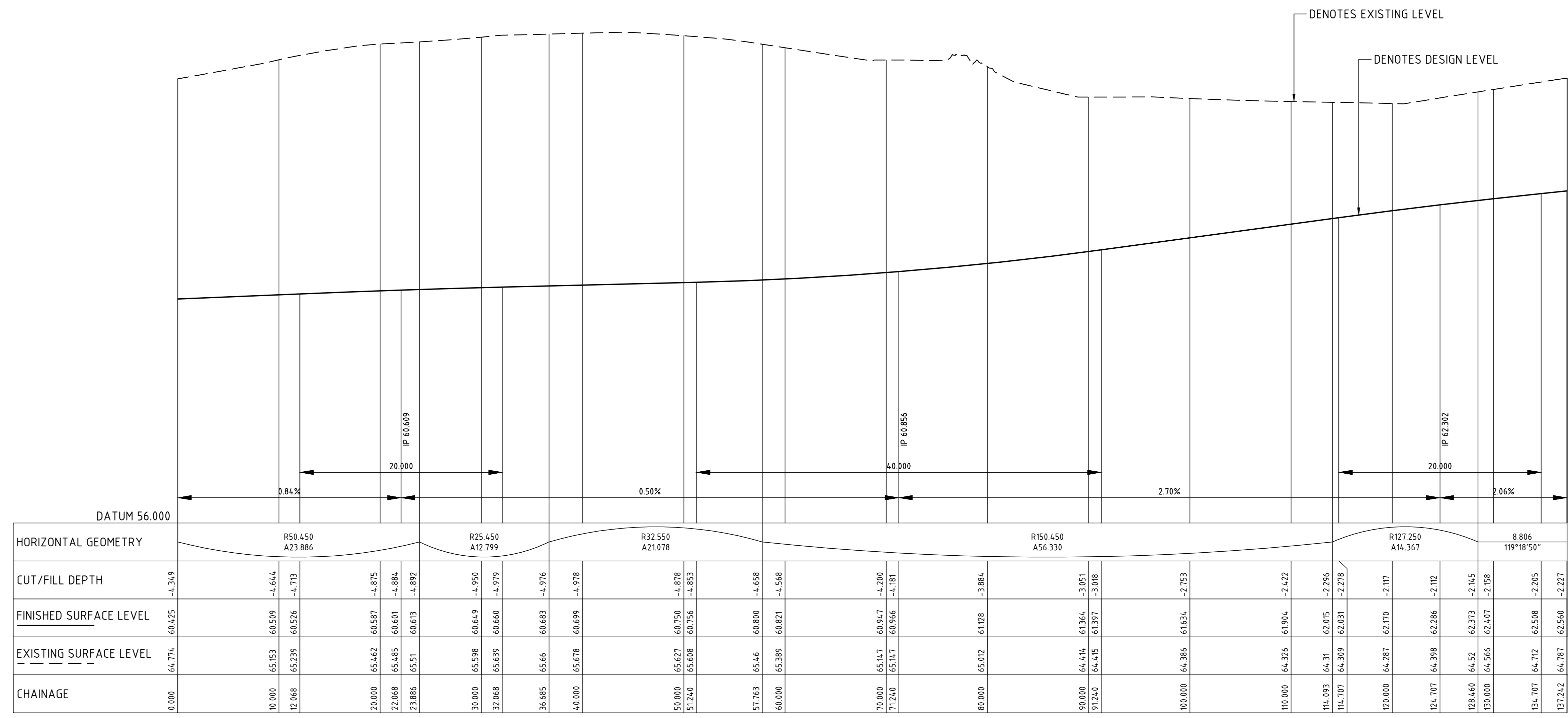

LONGITUDINAL SECTION - KR01
HORIZONTAL SCALE 1:250
VERTICAL SCALE 1:50

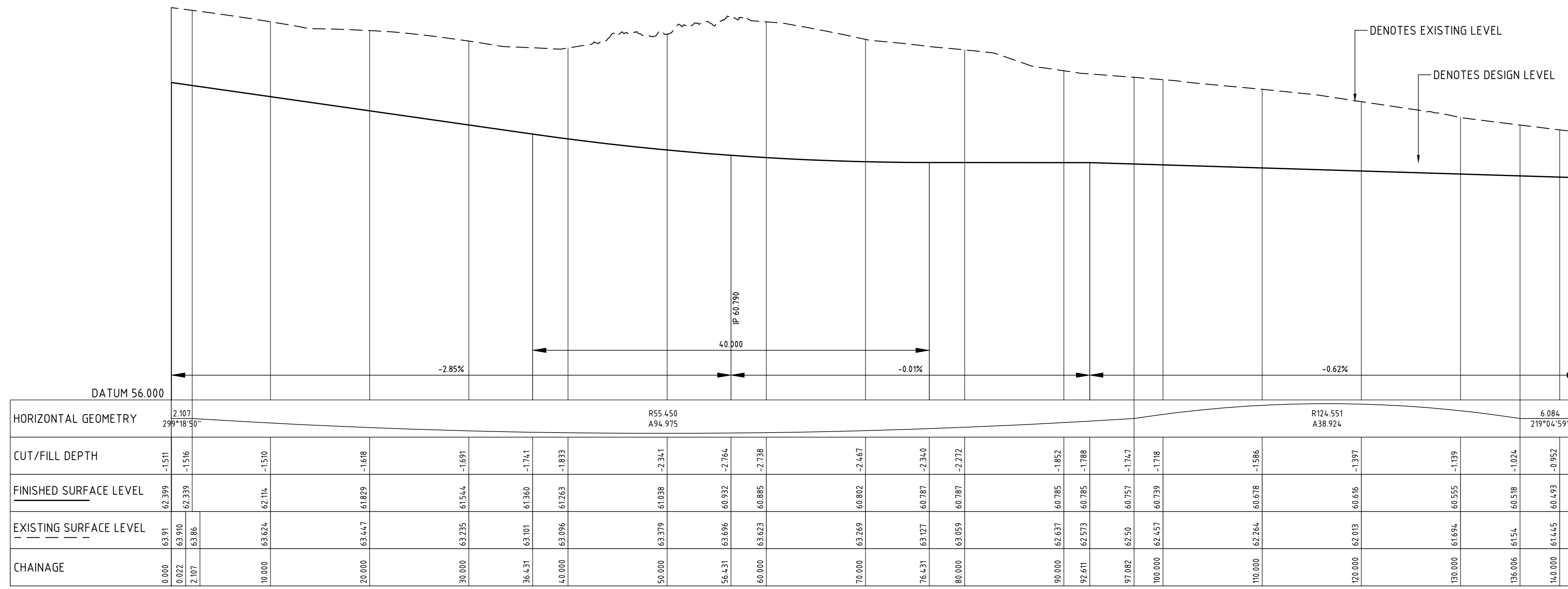

LONGITUDINAL SECTION - KR02
HORIZONTAL SCALE 1:250
VERTICAL SCALE 1:50

NOTES:
REFER TO DRAWING C543 FOR KERB RETURN PLAN.

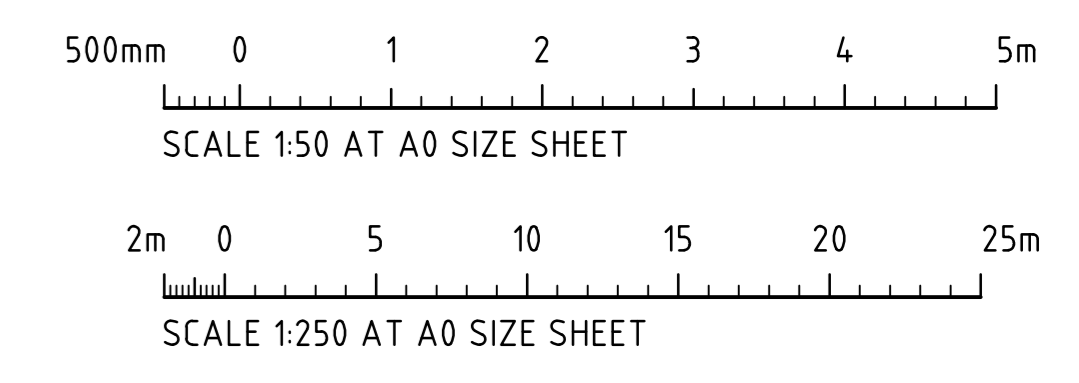

FOR SWC-3

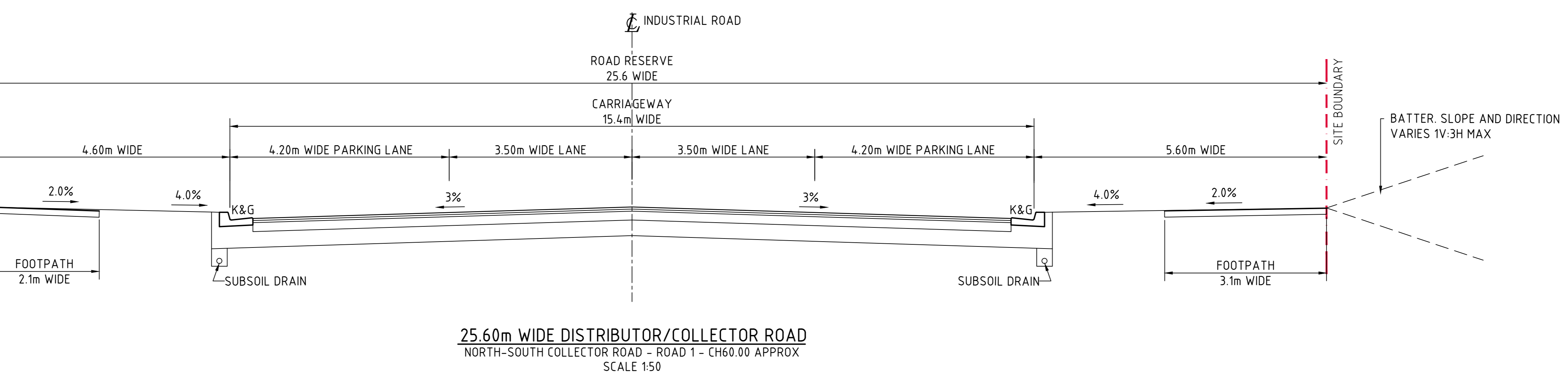
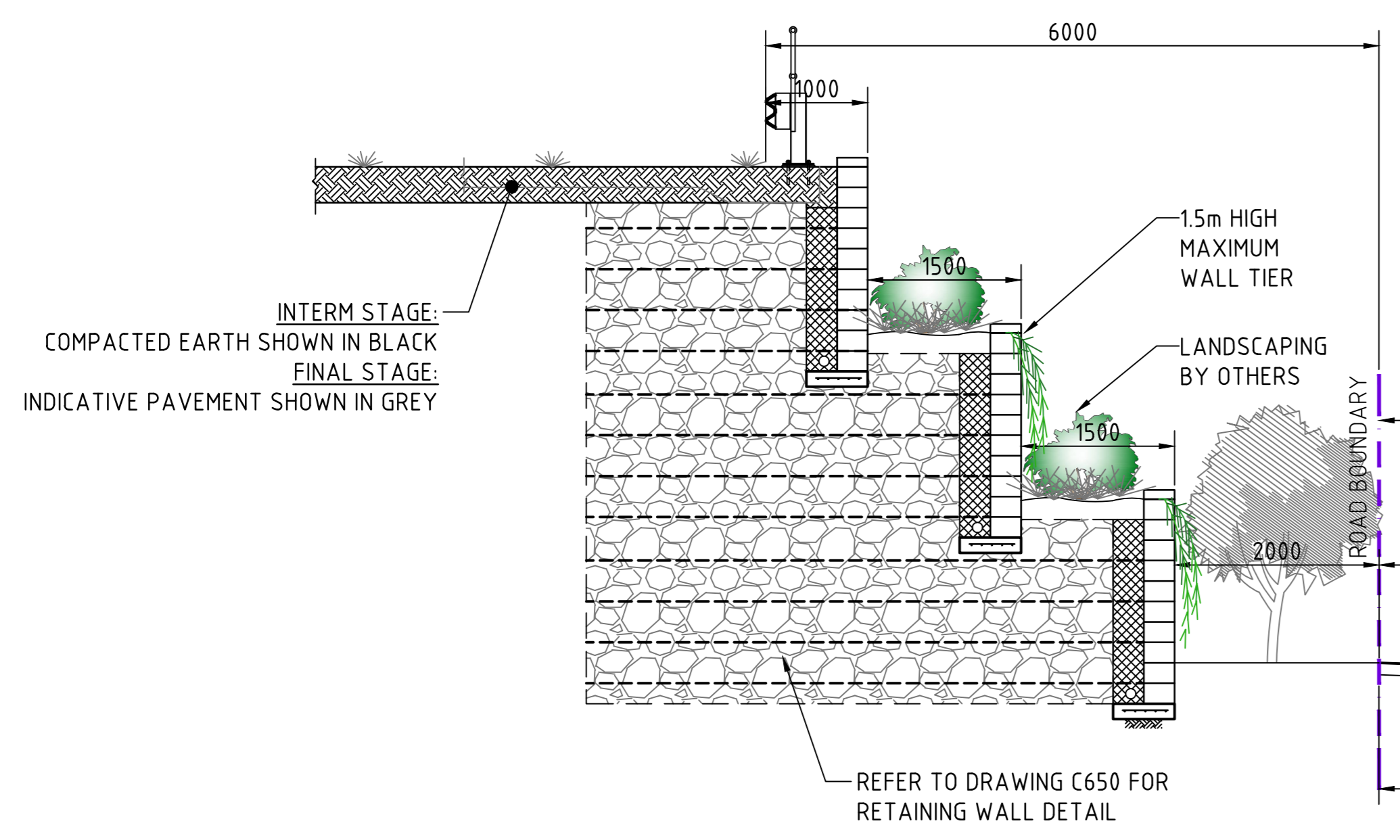
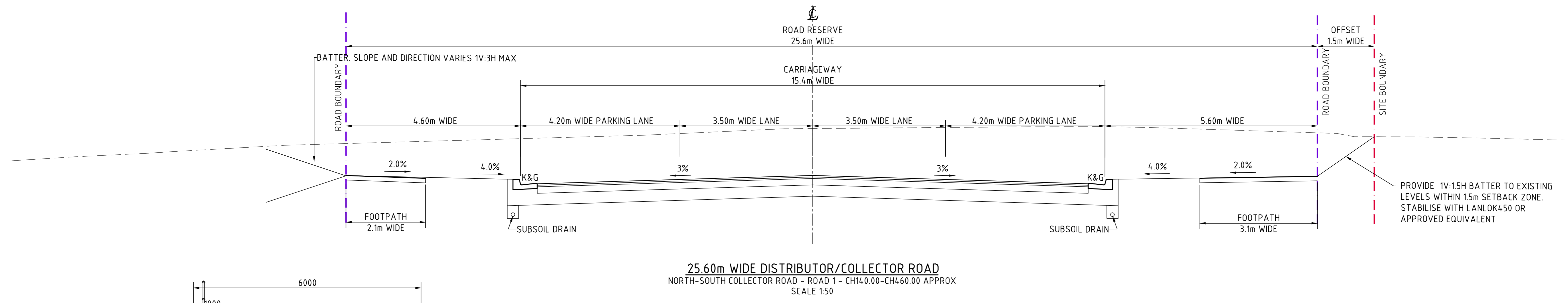
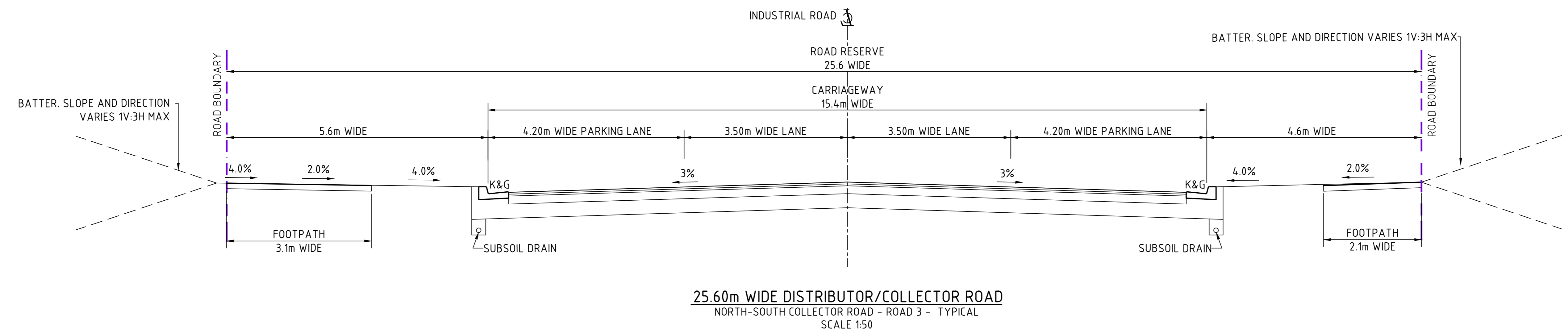
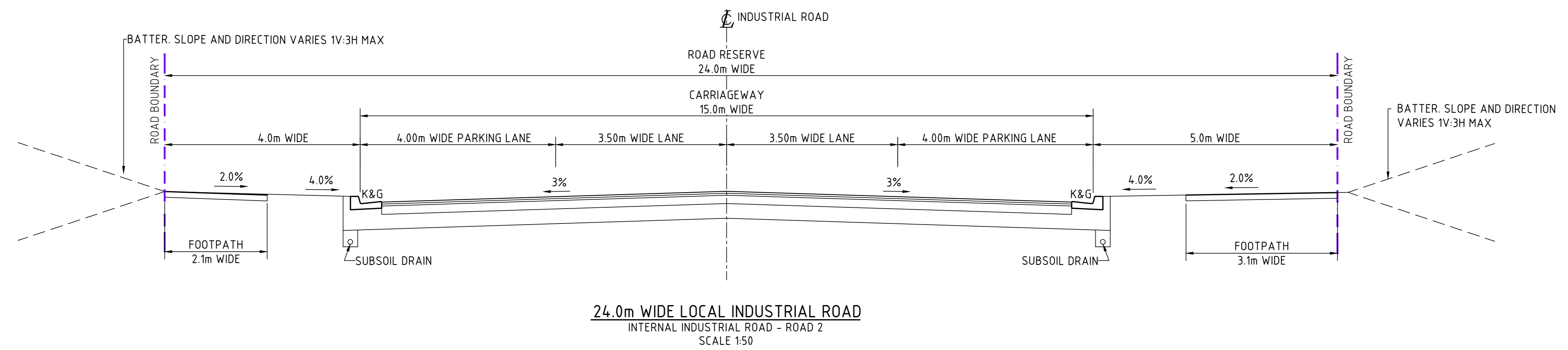

FOR SWC-3

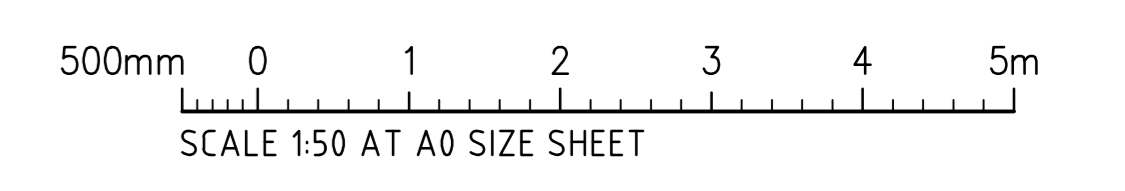

ISSUED FOR SWC-3 ISSUED FOR CONSTRUCTION ISSUED FOR PRELIMINARY ONLY AMENDMENTS		PROJECT MANAGER 		ARCHITECT 		CLIENT 		PROJECT ACCESS LOGISTICS PARK 884-928 MAMRE ROAD KEMPS CREEK, NSW		CONSULT AUSTRALIA 		Costin Roe Consulting Pty Ltd. AIN 50 003 696 446 PO Box 9419 Sydney NSW 1520 Levels 4 & 5 Woodhill Street, Millers Point NSW 2000 p: +61 2 9251 7699 f: +61 2 9241 3731 e: mail@costinroe.com.au w: costinroe.com.au		DRAWING TITLE ROADWORKS TYPICAL SECTIONS DRAWING No C014021.05-C550		ISSUE 2	
DATE	ISSUE	AMENDMENTS	DATE	ISSUE	AMENDMENTS	DATE	ISSUE	DESIGNED	DRAWN	DATE	CHECKED	SCALE	CAD REF.				
21.02.25	1							DW			MW	A0	C014021.05-C 550				

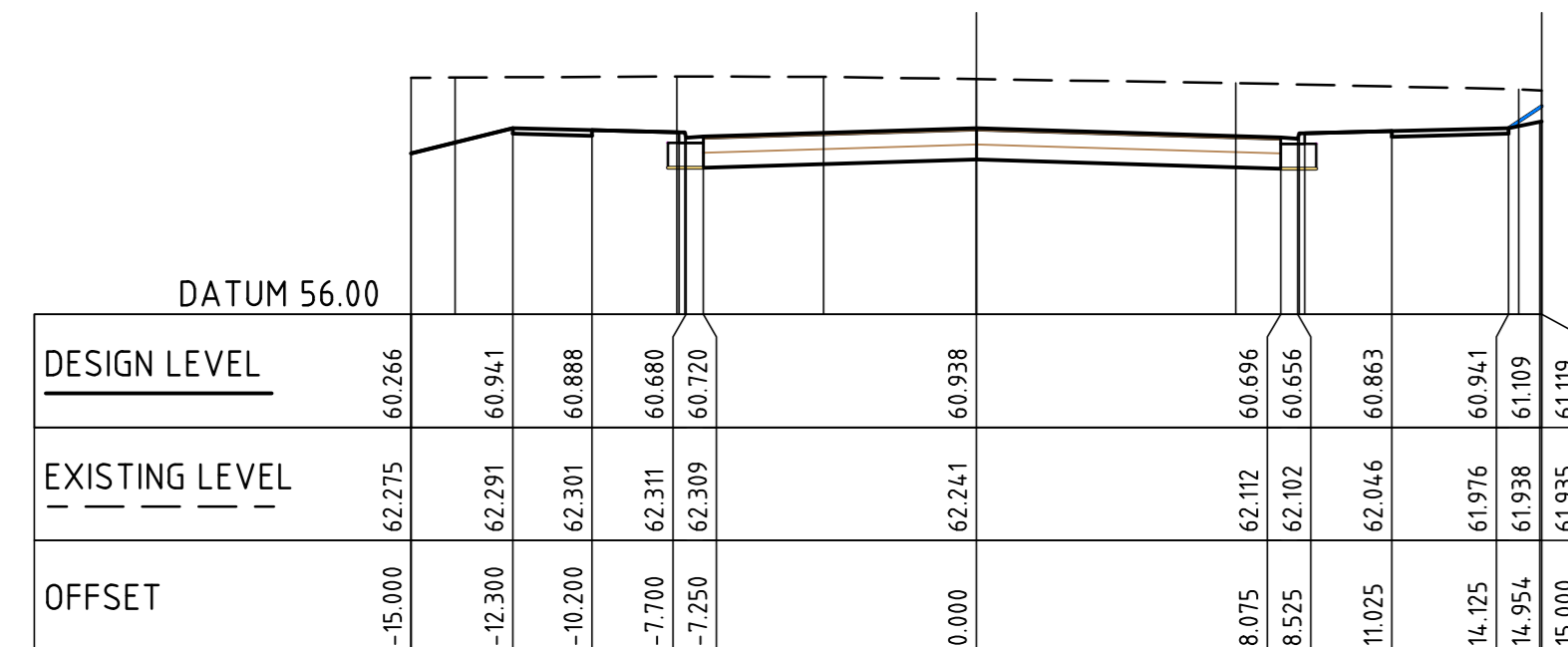

CL DIST RD 1
CH 500.000

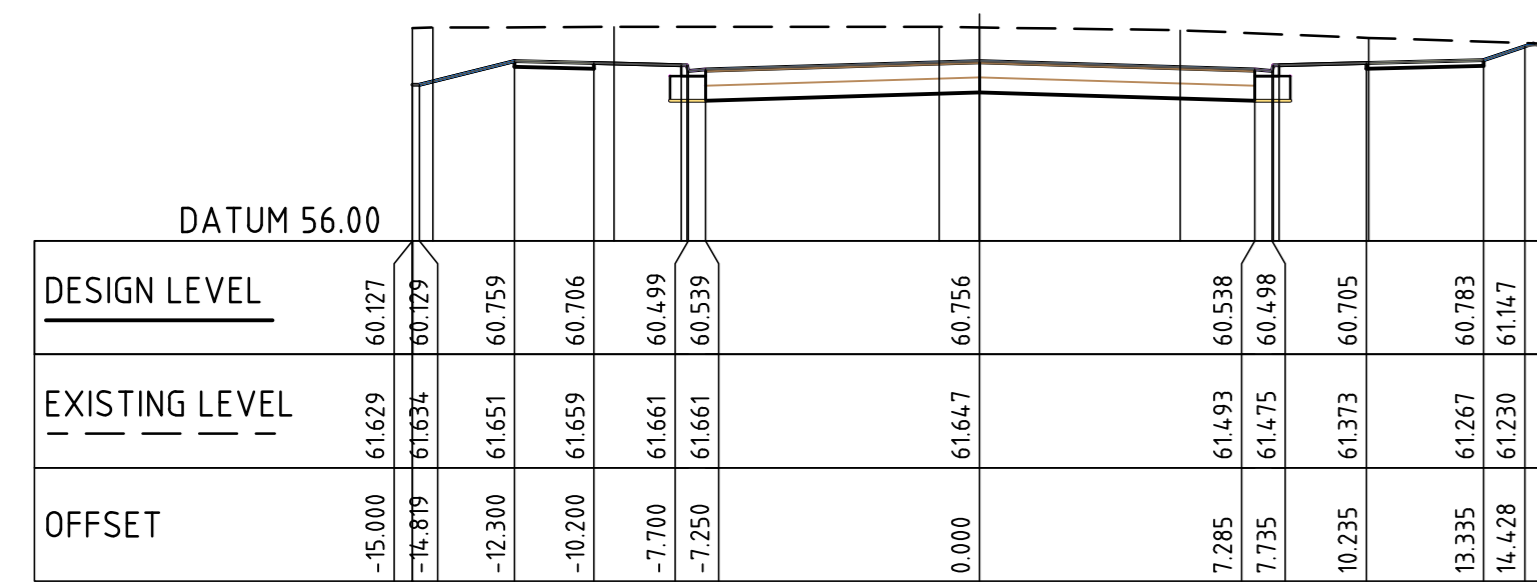

CL DIST RD 1
CH 480.000

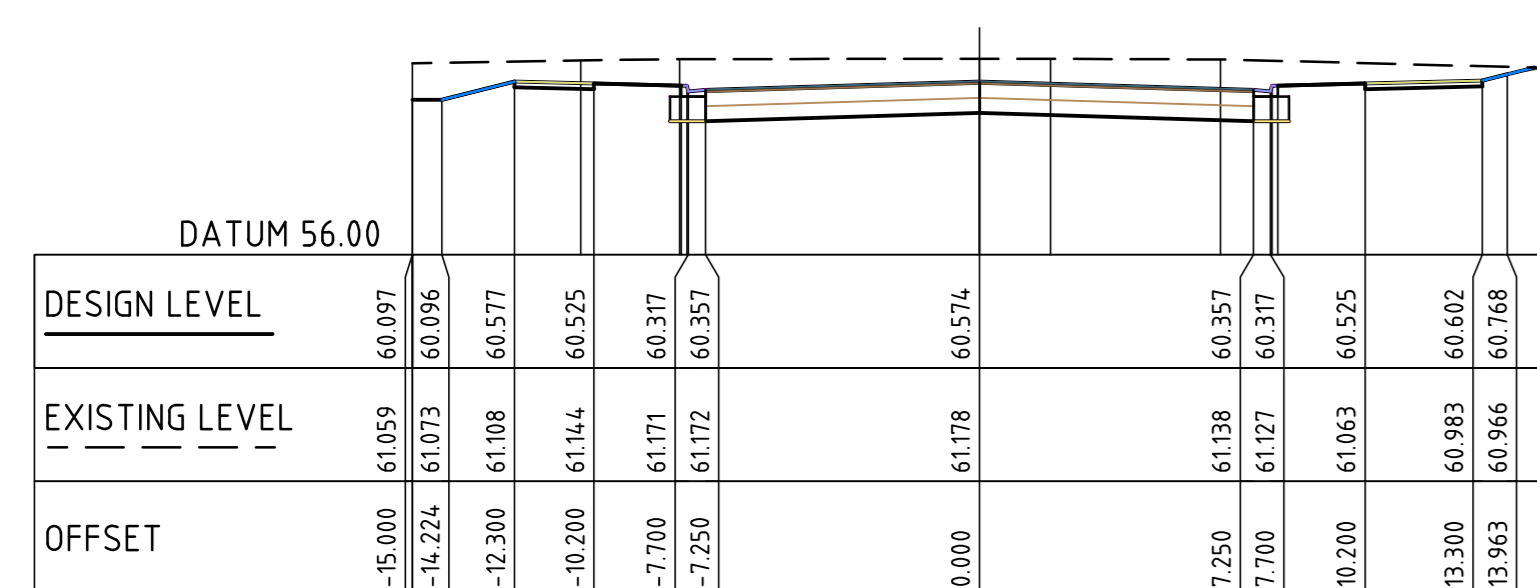

CL DIST RD 1
CH 460.000

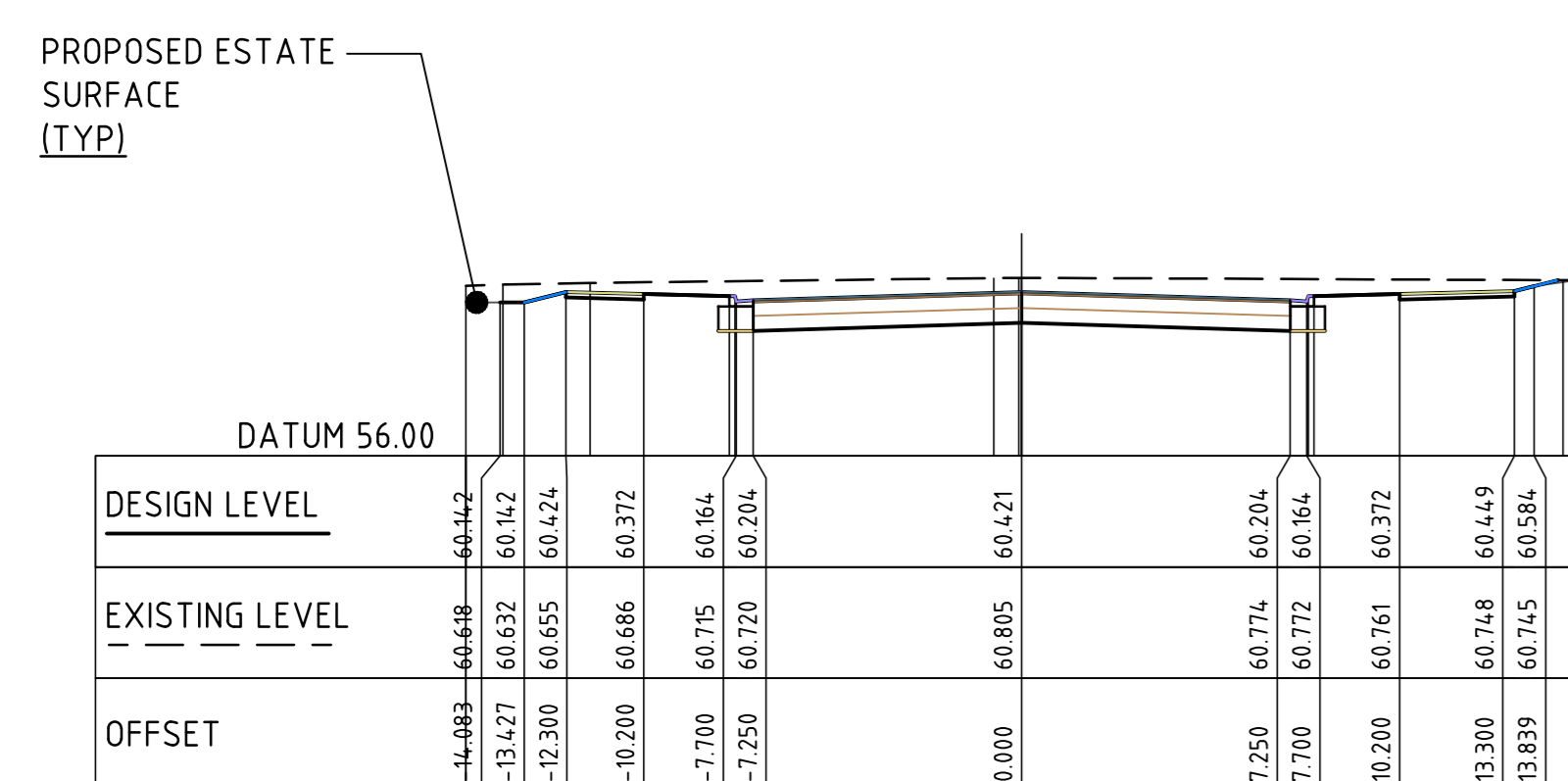

CL DIST RD 1
CH 440.000

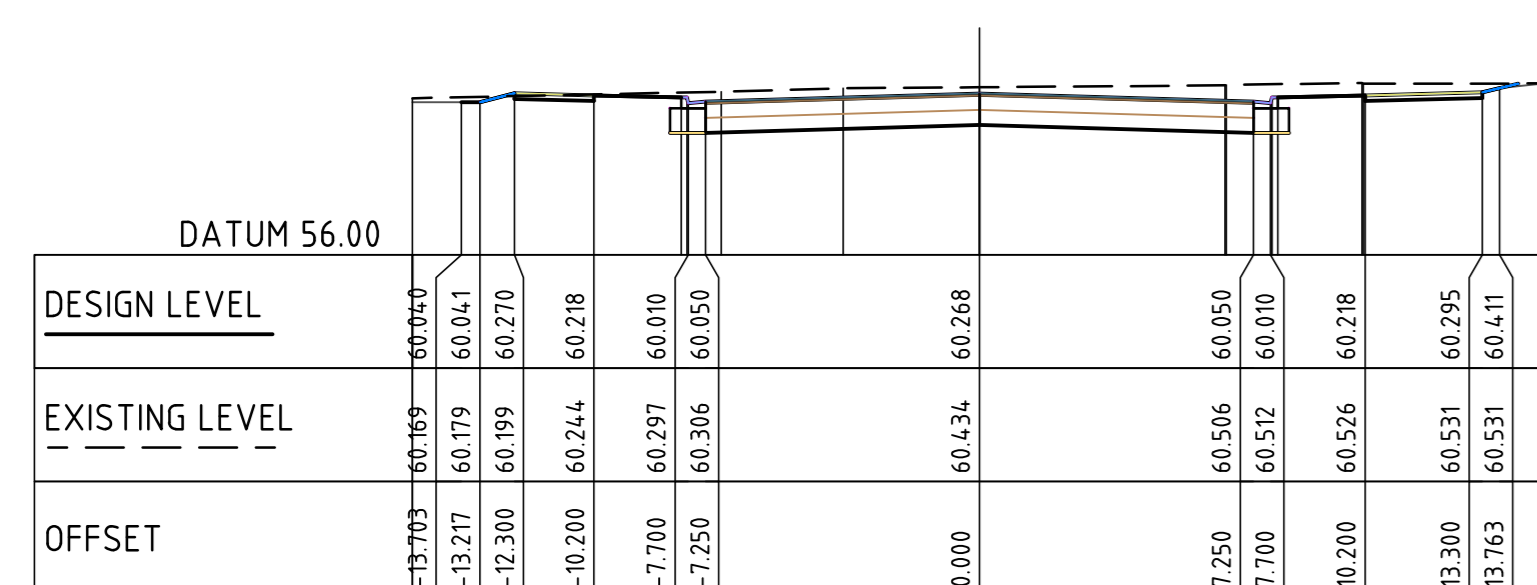

CL DIST RD 1
CH 420.000

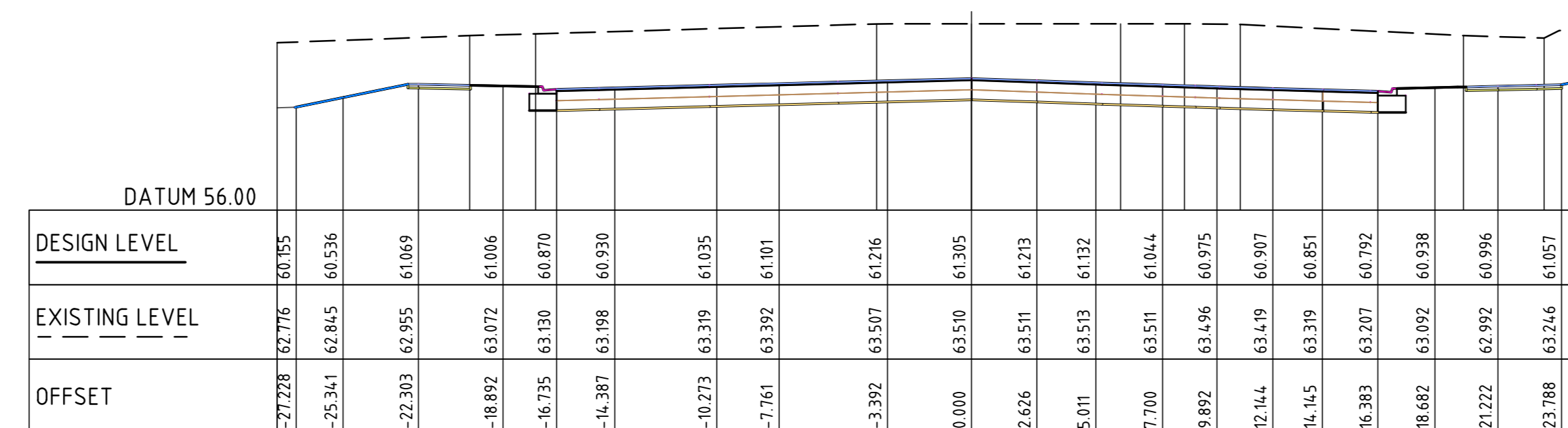

CL DIST RD 1
CH 540.000

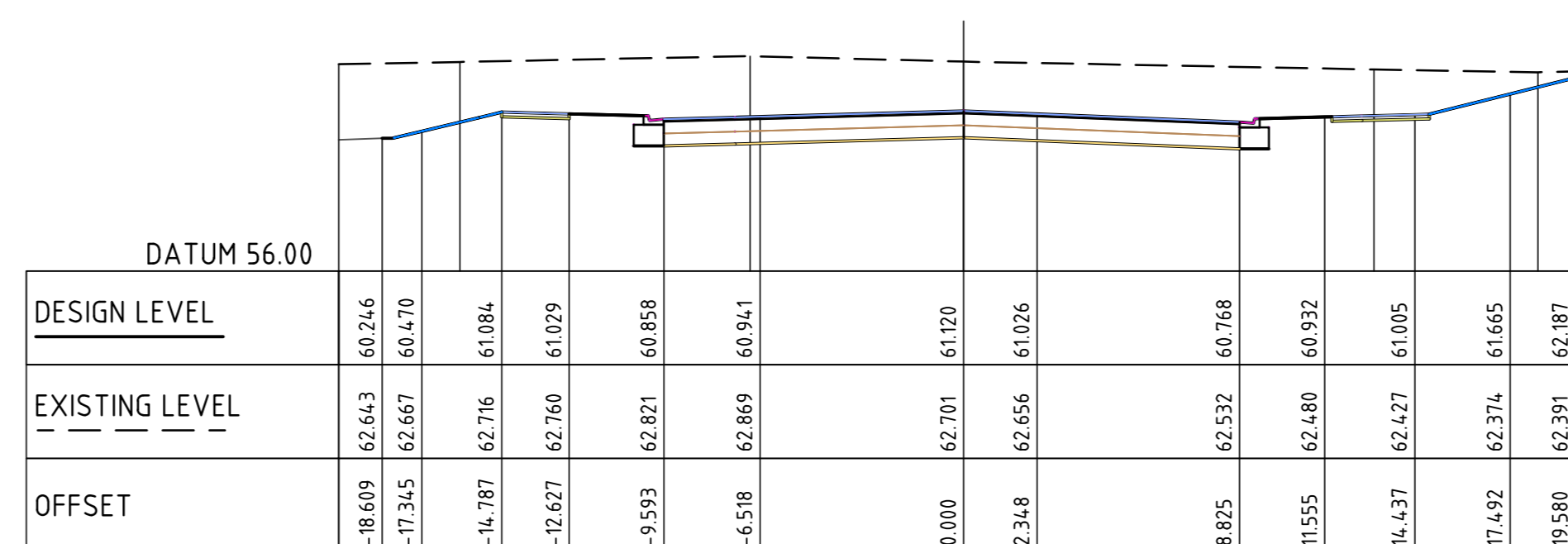

CL DIST RD 1
CH 520.000

FOR SWC-3

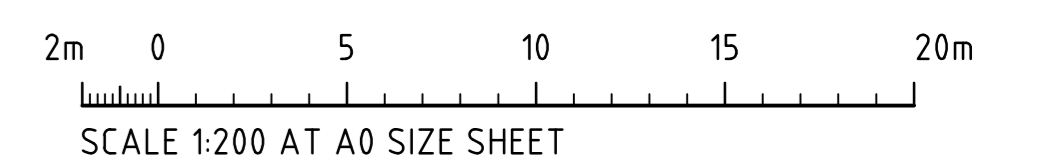

ISSUED FOR	DATE	ISSUE	AMENDMENTS
ISSUED FOR SWC-3	21.02.25	2	
ISSUED FOR CONSTRUCTION	24.07.24	1	
ISSUED FOR CONSTRUCTION	02.05.24	0	
ISSUED FOR PRELIMINARY ONLY	15.03.24	A	
AMENDMENTS	DATE	ISSUE	AMENDMENTS

PROJECT MANAGER
ProjectStrategy

ARCHITECT
nettleton|tbe

CLIENT
BURTON
Civil Engineering Contractors

PROJECT
ACCESS LOGISTICS PARK
884-928 MAMRE ROAD
KEMPS CREEK, NSW

CONSULT AUSTRALIA

Costin Roe Consulting Pty Ltd.
ABN 50 003 696 446
PO Box 7419 Sydney NSW 1220
Level 4, 4 Windmill Street, Milsons Point NSW 2000
p: +61 2 9251 7699 e: +61 2 9241 3731
c: mail@costinroe.com.au w: costinroe.com.au

CRC
COSTIN ROE CONSULTING
CIVIL & STRUCTURAL ENGINEERS

DRAWING TITLE
ROADWORKS SECTIONS SHEET 2
DRAWING No. **C014021.05-C562** ISSUE **2**

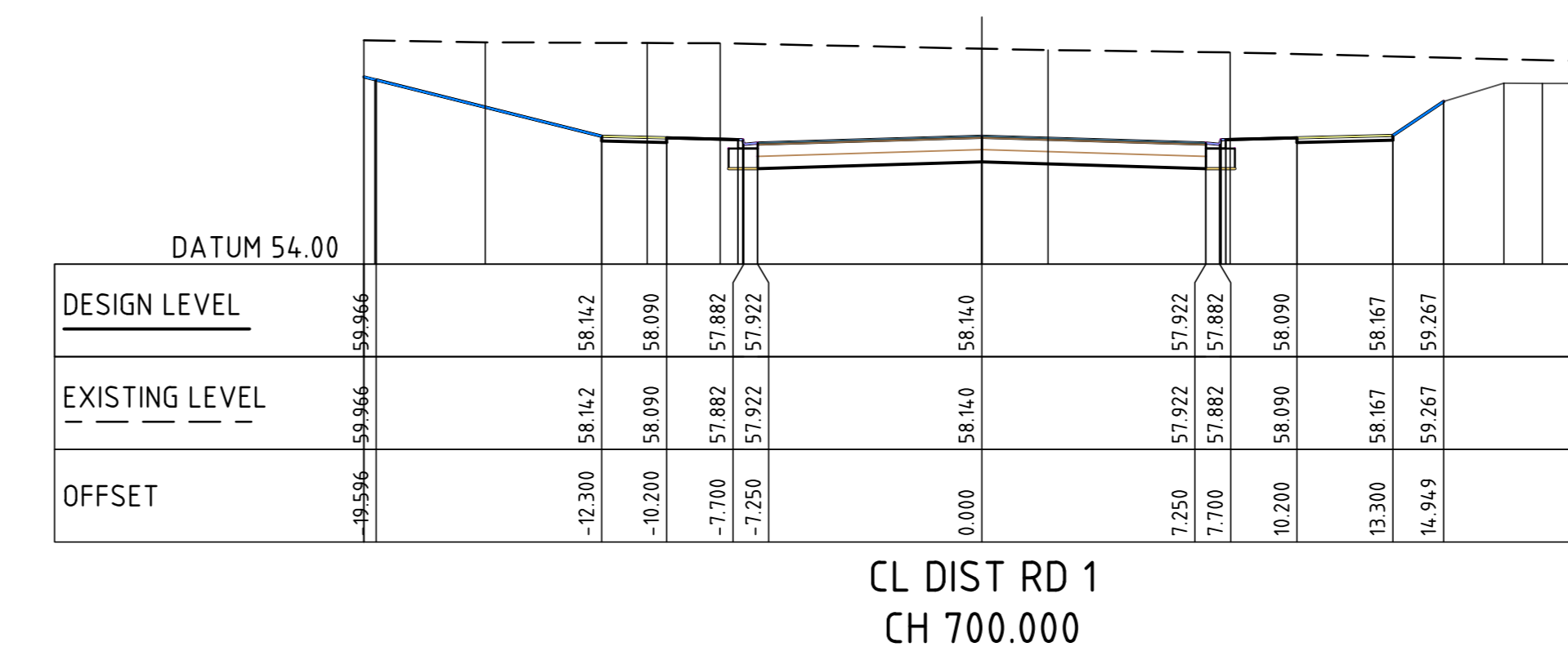
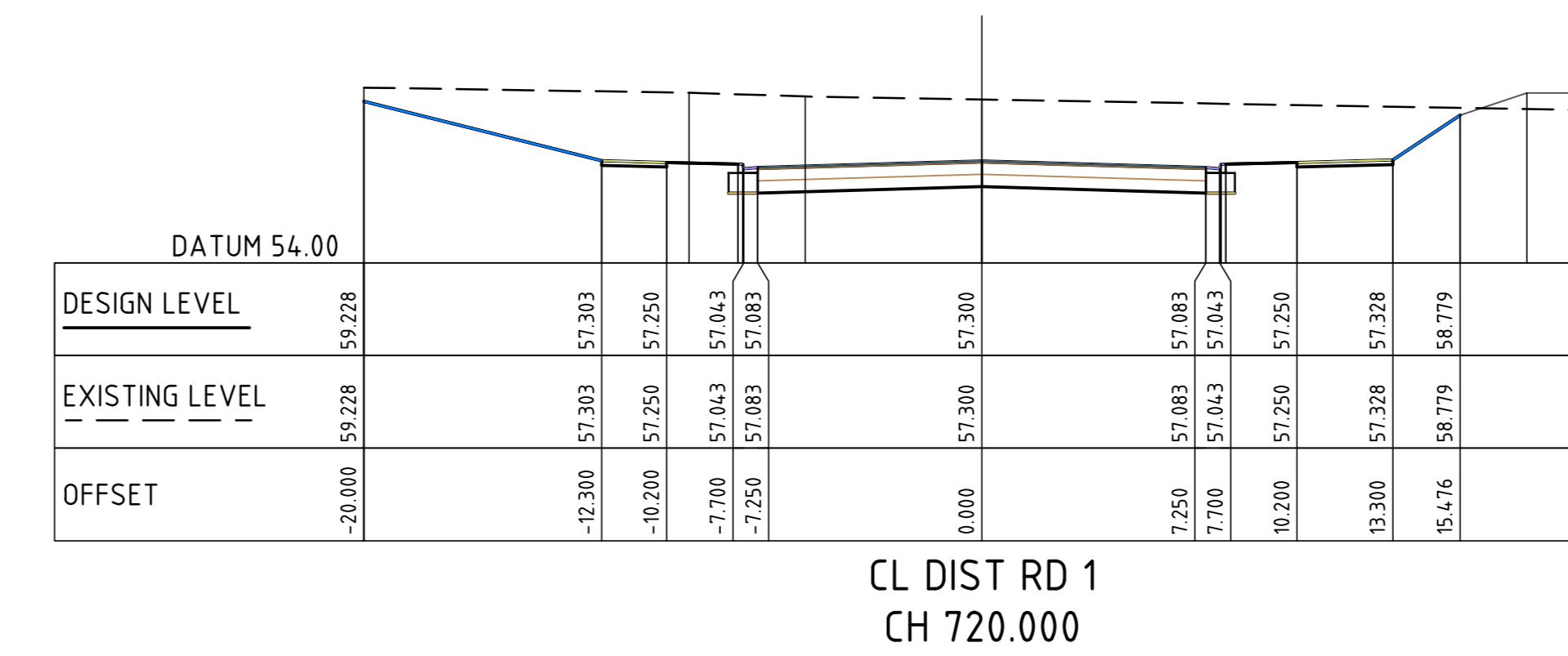
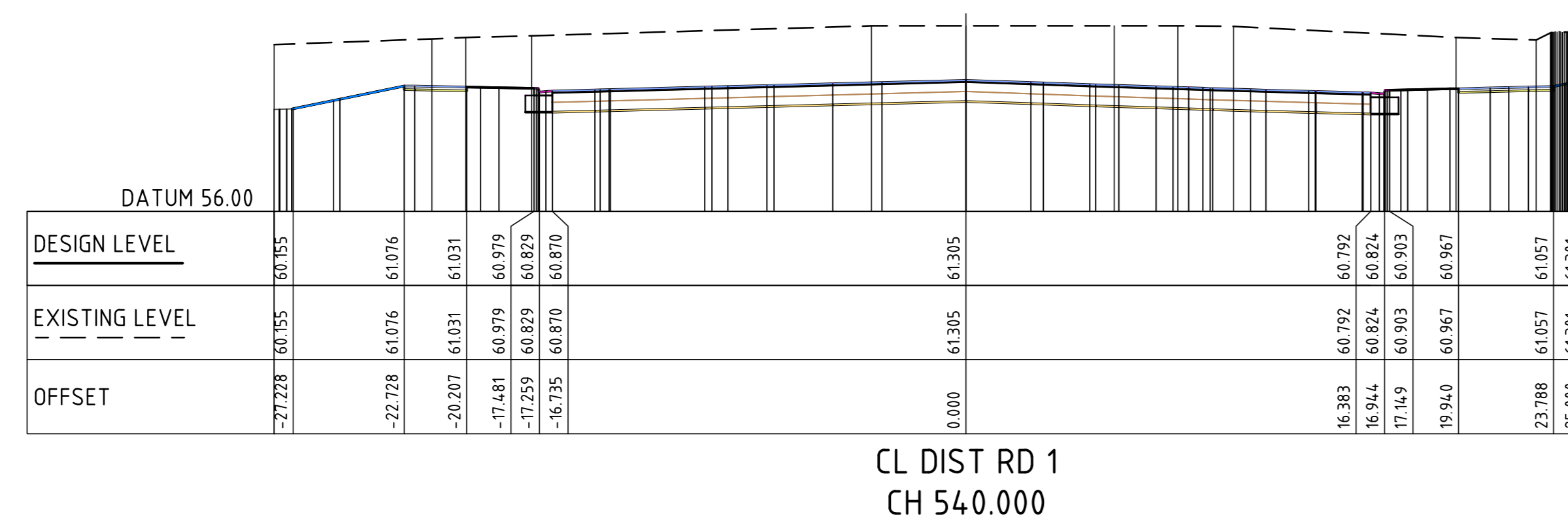
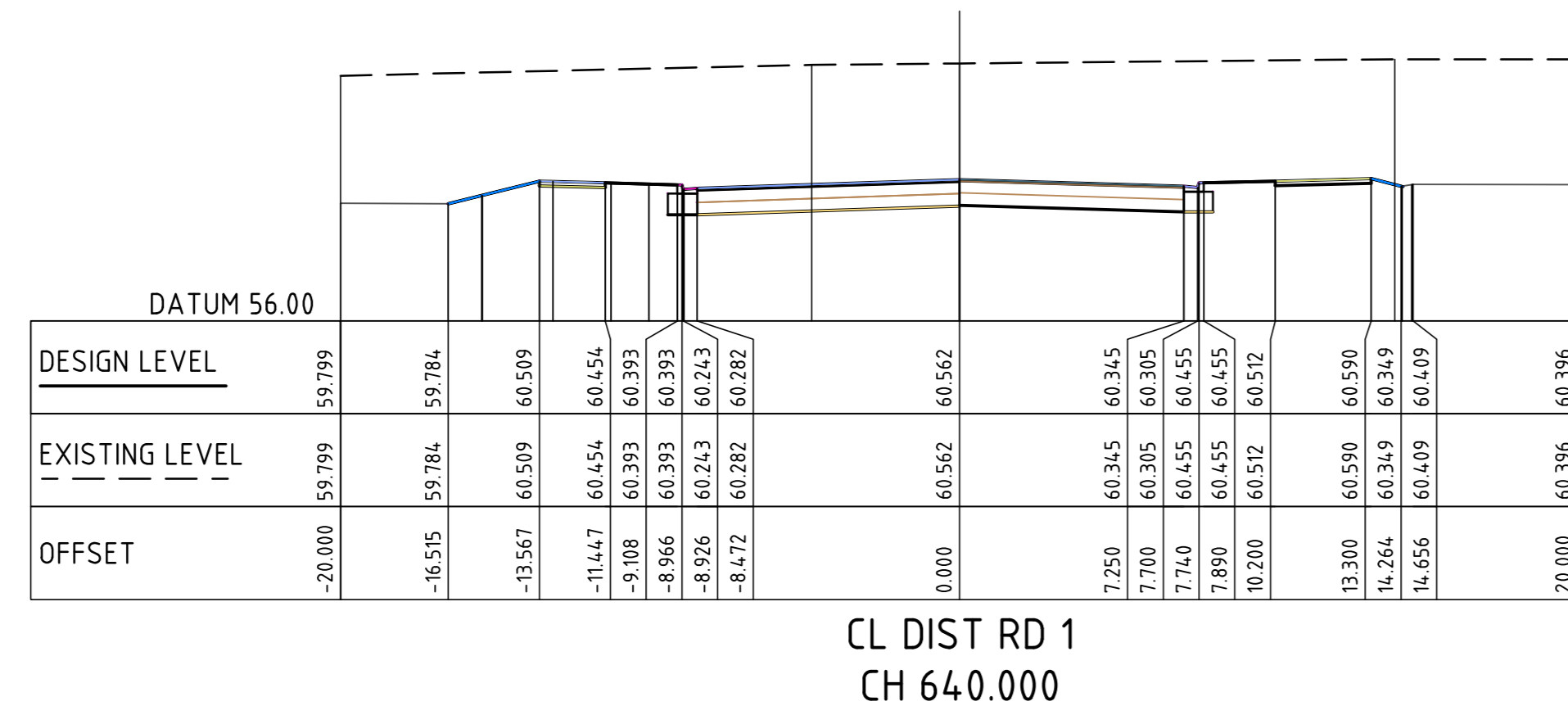
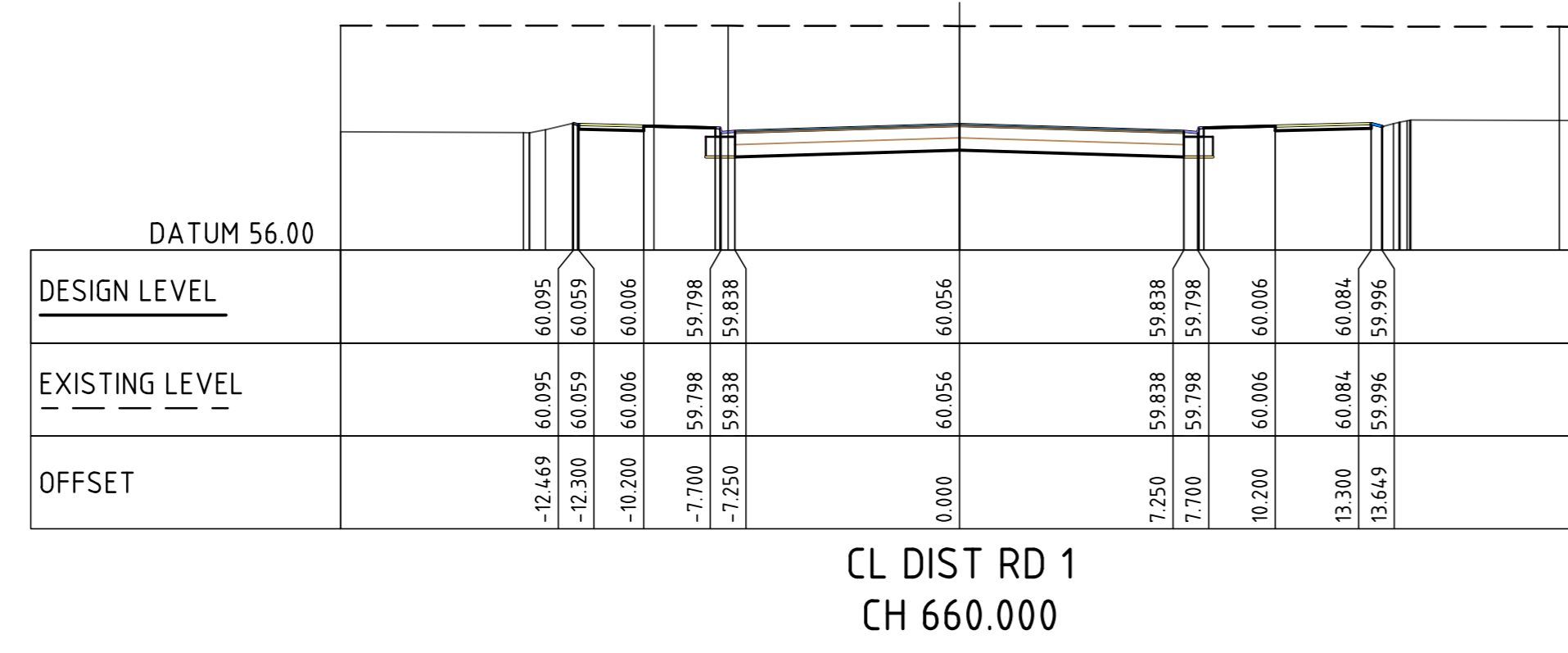
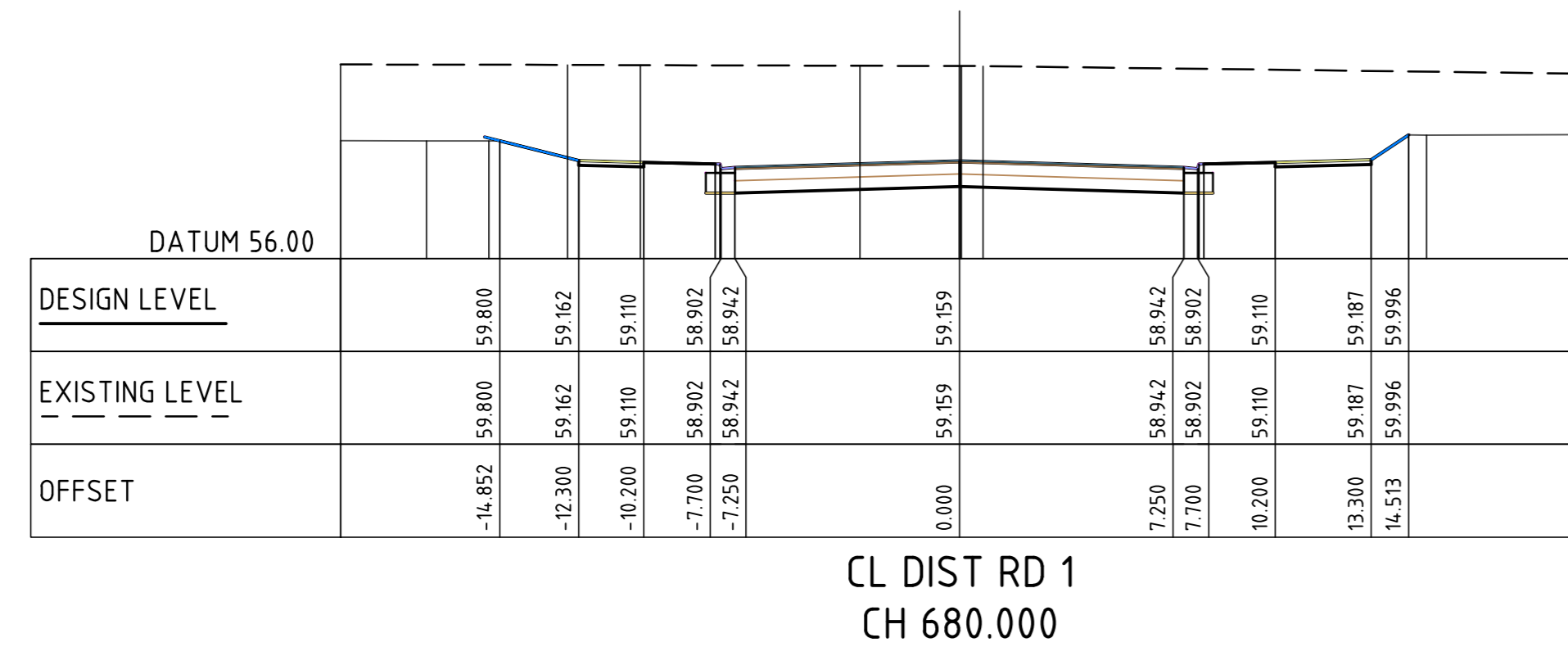

FOR SWC-3

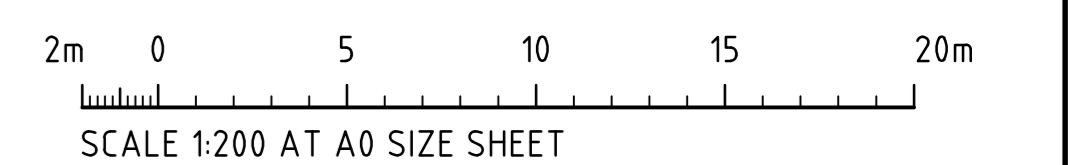

ISSUED FOR SWC-3	21.02.25	2
ISSUED FOR CONSTRUCTION	24.07.24	1
ISSUED FOR CONSTRUCTION	02.05.24	0
ISSUED FOR PRELIMINARY ONLY	15.03.24	A
AMENDMENTS	DATE	ISSUE

AMENDMENTS	DATE	ISSUE	AMENDMENTS	DATE	ISSUE

PROJECT MANAGER

ARCHITECT

CLIENT

PROJECT
 ACCESS LOGISTICS PARK
 884-928 MAMRE ROAD
 KEMPS CREEK, NSW

CONSULT AUSTRALIA

Costin Roe Consulting Pty Ltd.
 AIN 50 003 696 446
 PO Box 7419 Sydney NSW 1220
 Level 4, 4 Woodmill Street, Milperra Point NSW 2000
 p: +61 2 9251 7699 e: +61 2 9241 3731
 c: mail@costinroe.com.au w: costinroe.com.au

CRC
 COSTIN ROE CONSULTING
 CIVIL & STRUCTURAL ENGINEERS

DRAWING TITLE
 ROADWORKS SECTIONS
 SHEET 3
 DRAWING No C014.021.05-C563
 ISSUE 2

HOLD

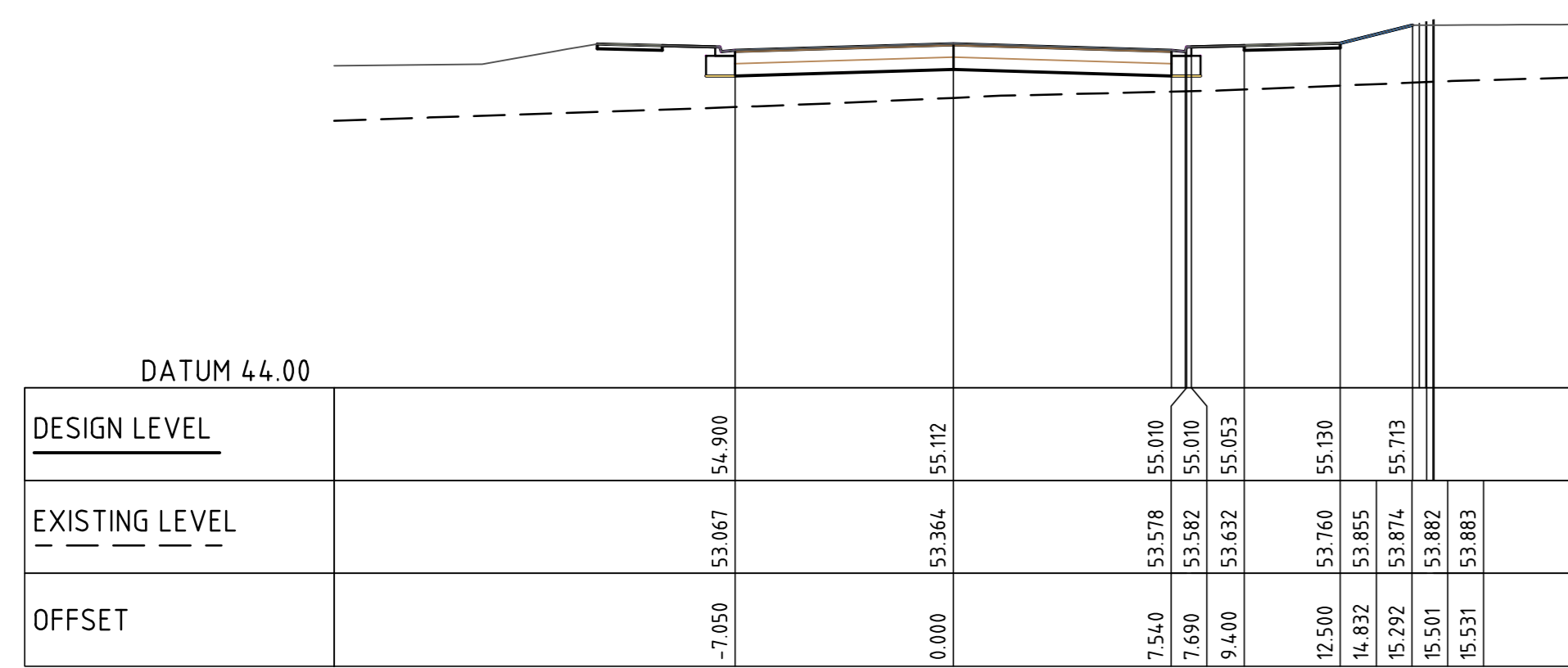

CL IND RD 1
CH 100.000
SCALE 1:200

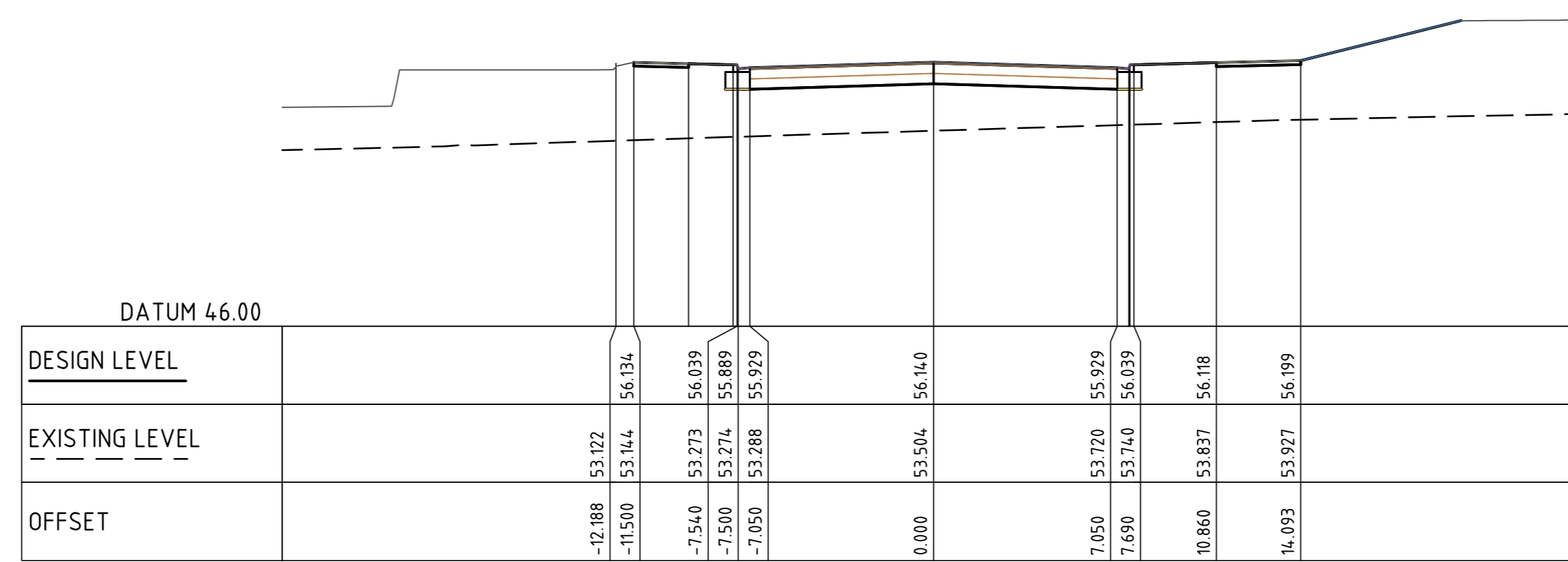

CL IND RD 1
CH 180.000
SCALE 1:200

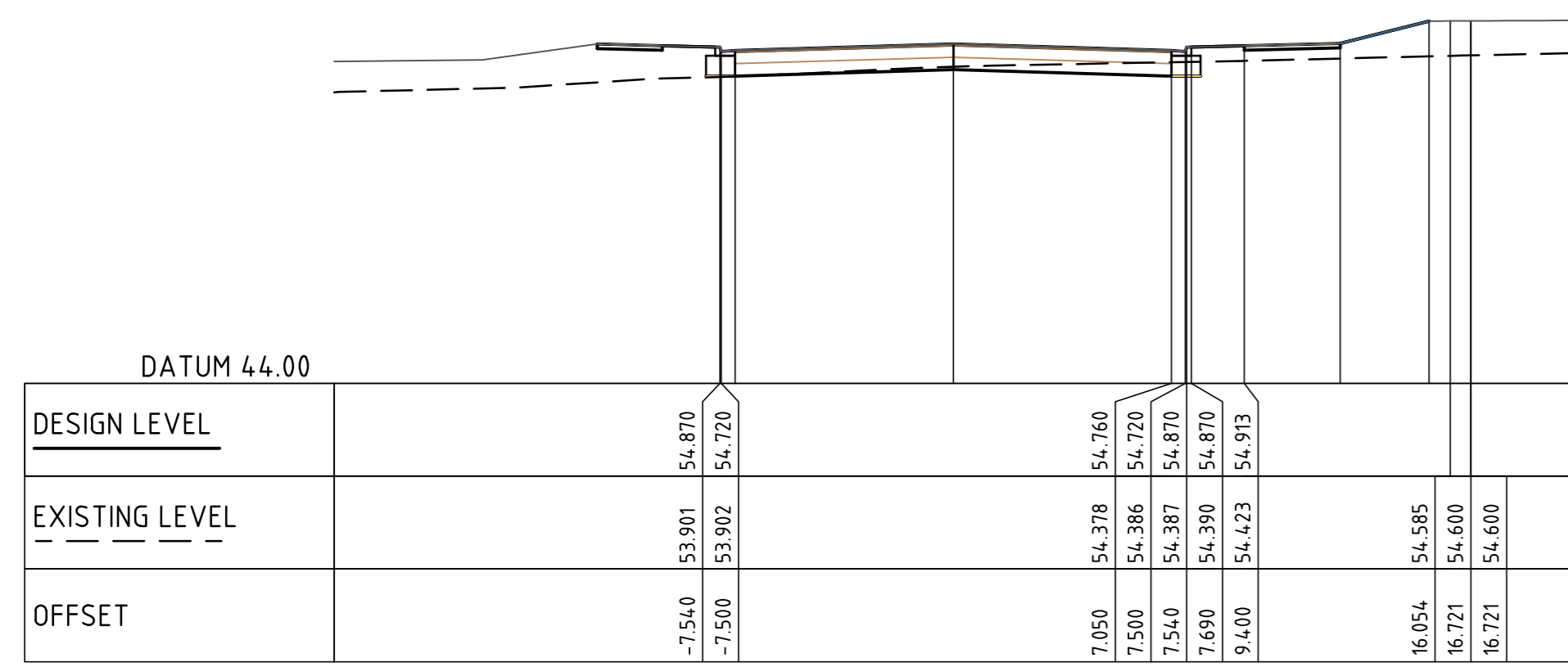

CL IND RD 1
CH 80.000
SCALE 1:200

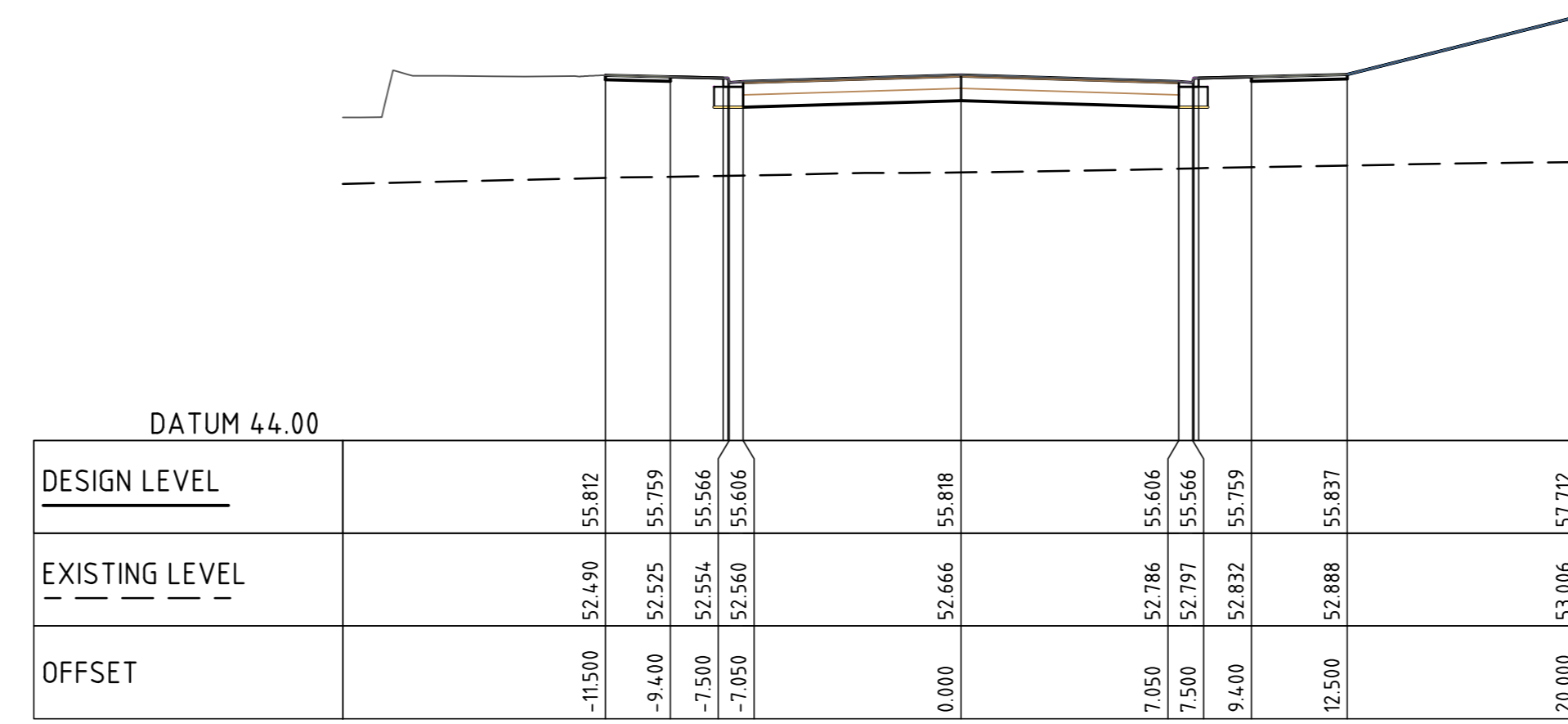

CL IND RD 1
CH 160.000
SCALE 1:200

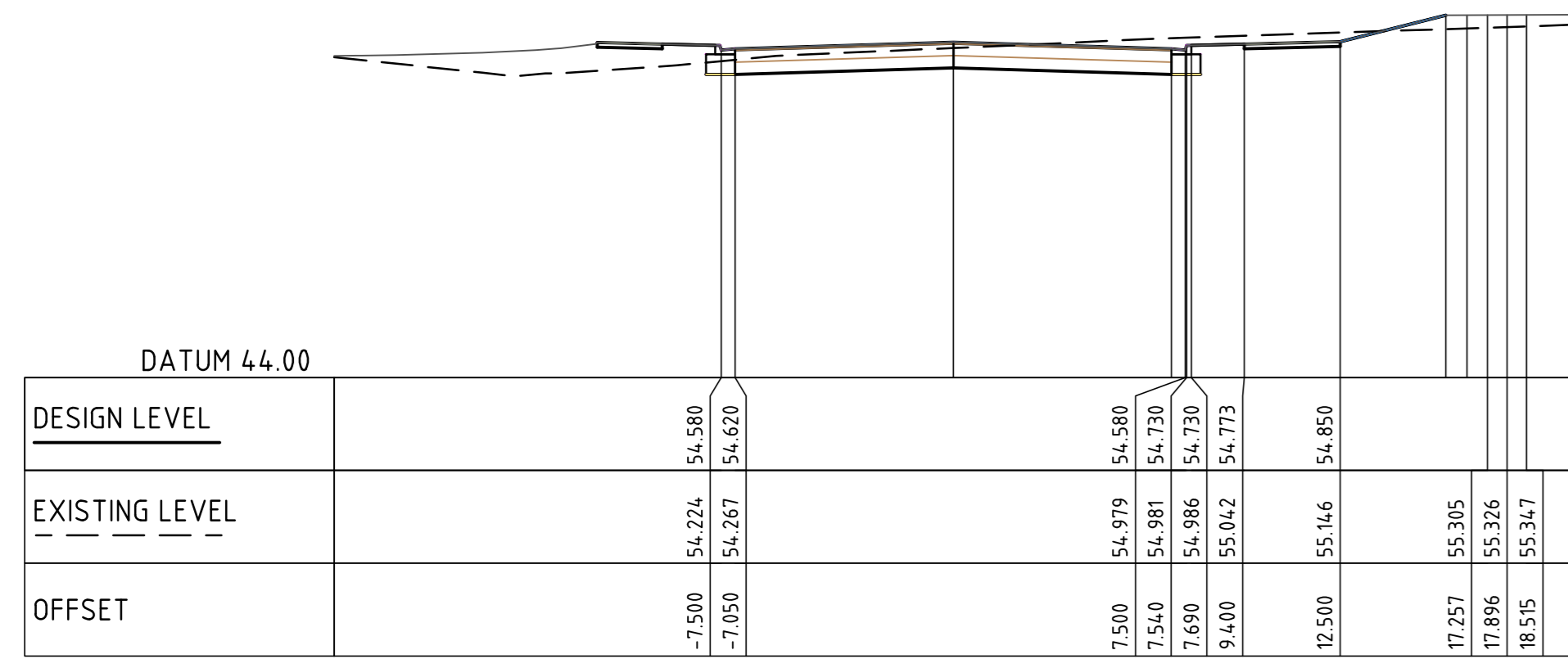

CL IND RD 1
CH 60.000
SCALE 1:200

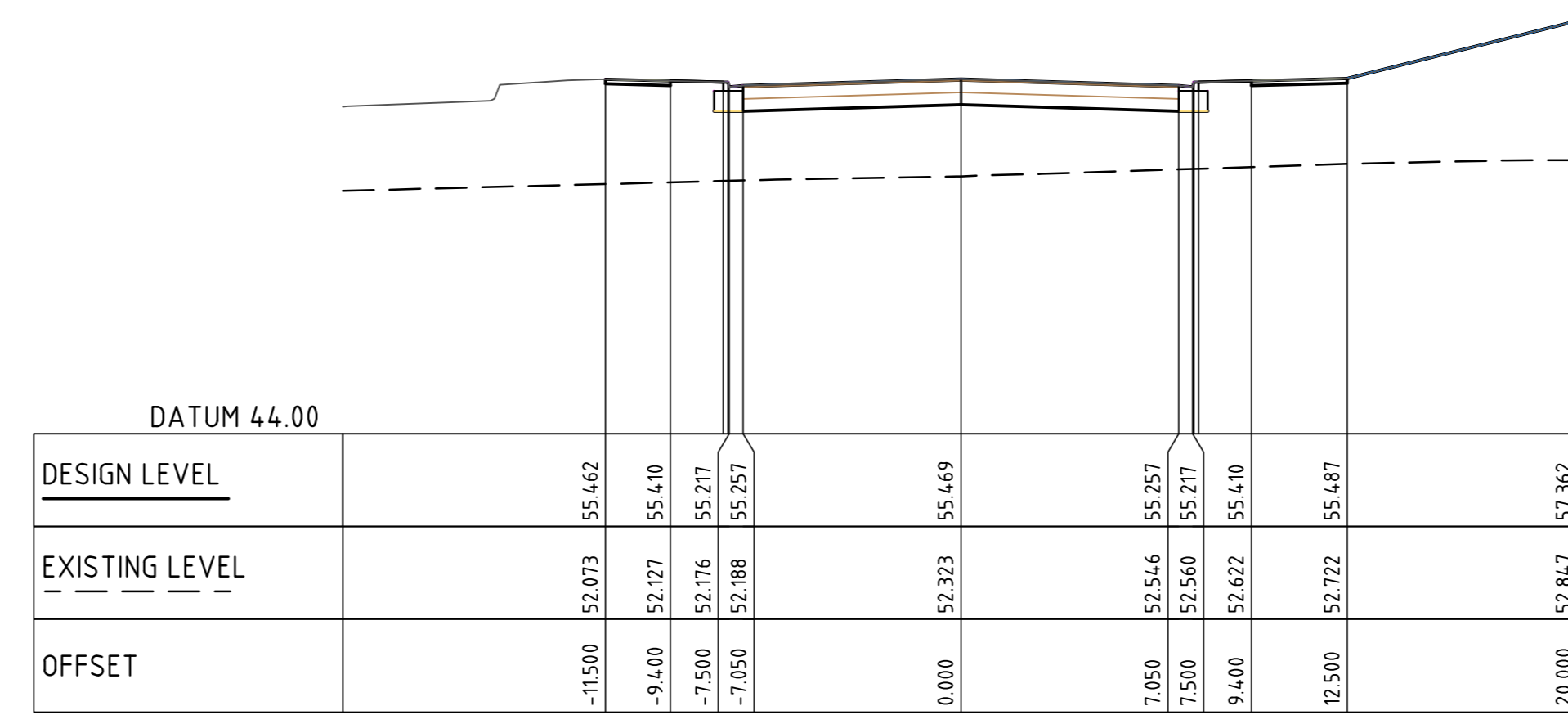

CL IND RD 1
CH 140.000
SCALE 1:200

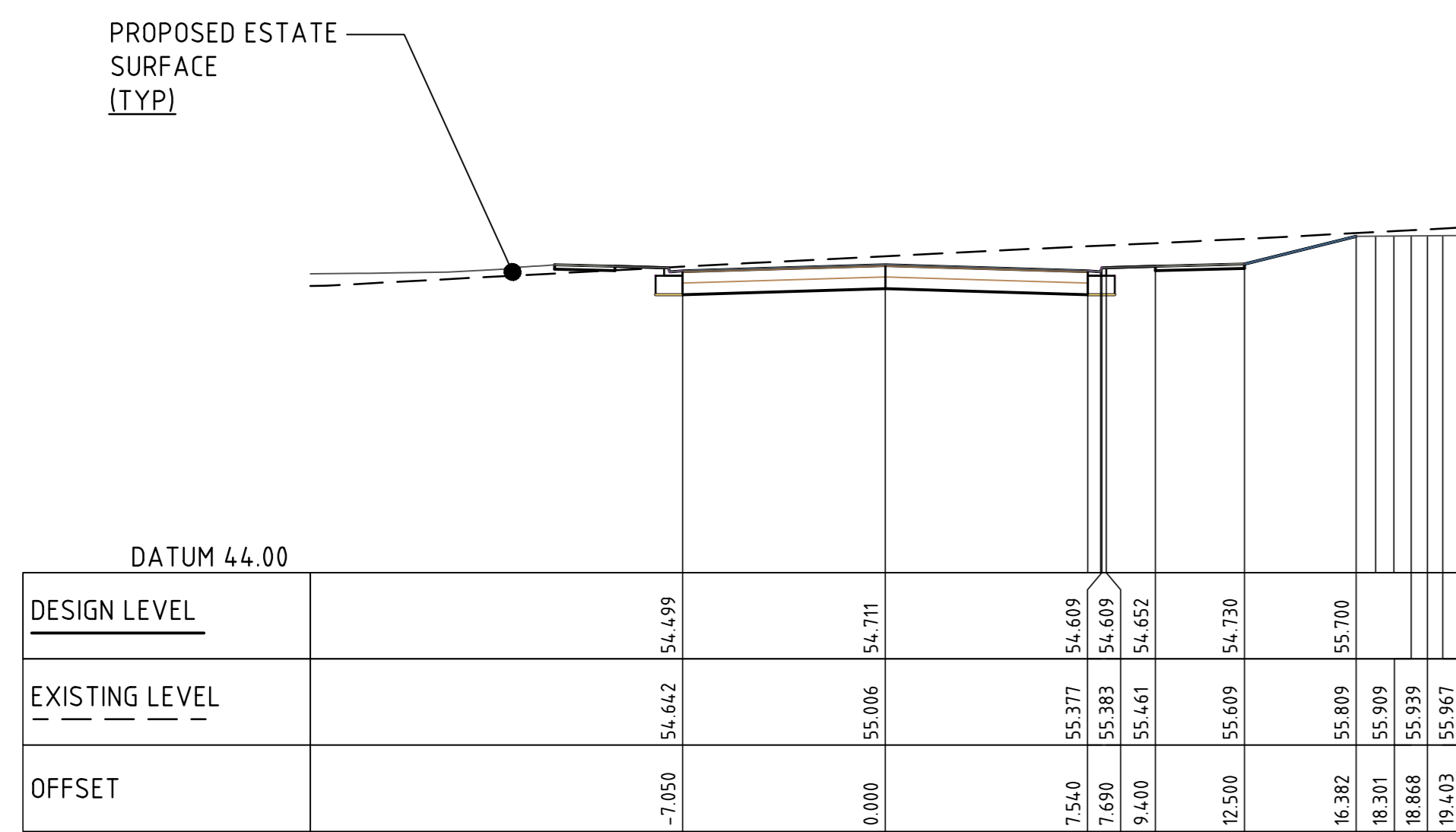

CL IND RD 1
CH 40.000
SCALE 1:200

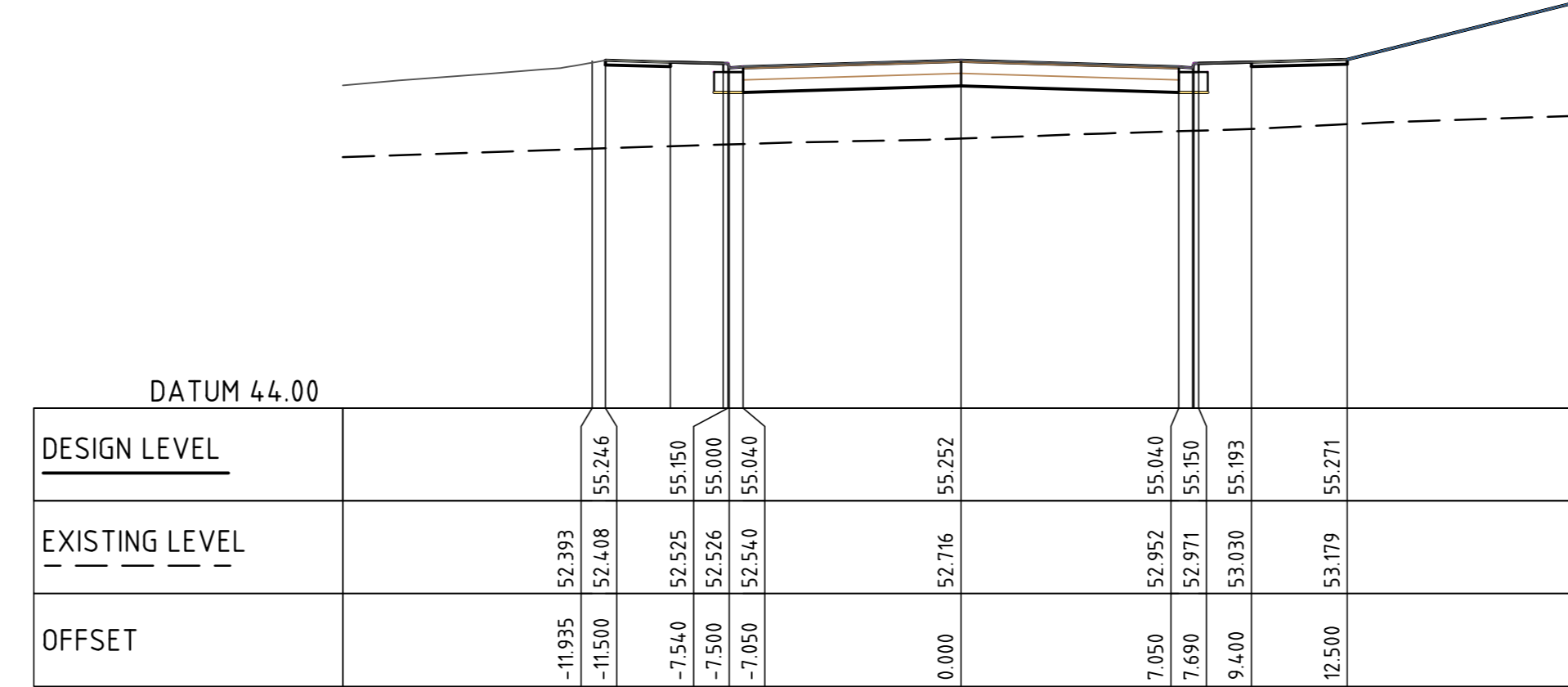

CL IND RD 1
CH 120.000
SCALE 1:200

FOR SWC-3

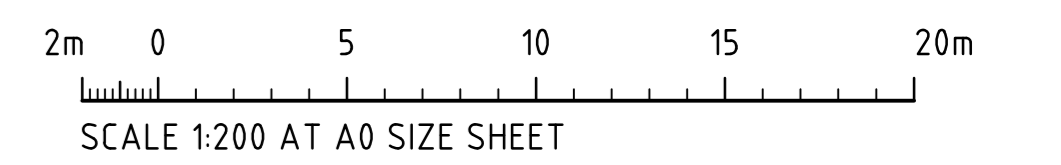

ISSUED FOR SWC-3	21.02.25	3			
ISSUED FOR CONSTRUCTION	24.07.24	2			
ISSUED FOR CONSTRUCTION	08.05.24	1			
ISSUED FOR CONSTRUCTION	02.05.24	0			
ISSUED FOR PRELIMINARY ONLY	15.03.24	A			
AMENDMENTS	DATE	ISSUE	AMENDMENTS	DATE	ISSUE

PROJECT MANAGER

ARCHITECT

CLIENT

PROJECT
ACCESS LOGISTICS PARK
884-928 MAMRE ROAD
KEMPS CREEK, NSW

Costin Roe Consulting Pty Ltd.
ABN 50 003 696 446
PO Box 7419 Sydney NSW 1220
Level 4, 4 Windmill Street, Milsons Point NSW 2000
p: +61 2 9251 7699 e: mail@costinroe.com.au w: costinroe.com.au

CIVIL & STRUCTURAL ENGINEERS

DRAWING TITLE
ROADWORKS SECTIONS
SHEET 4
DRAWING No C014.021.05-C564
ISSUE 3

HOLD

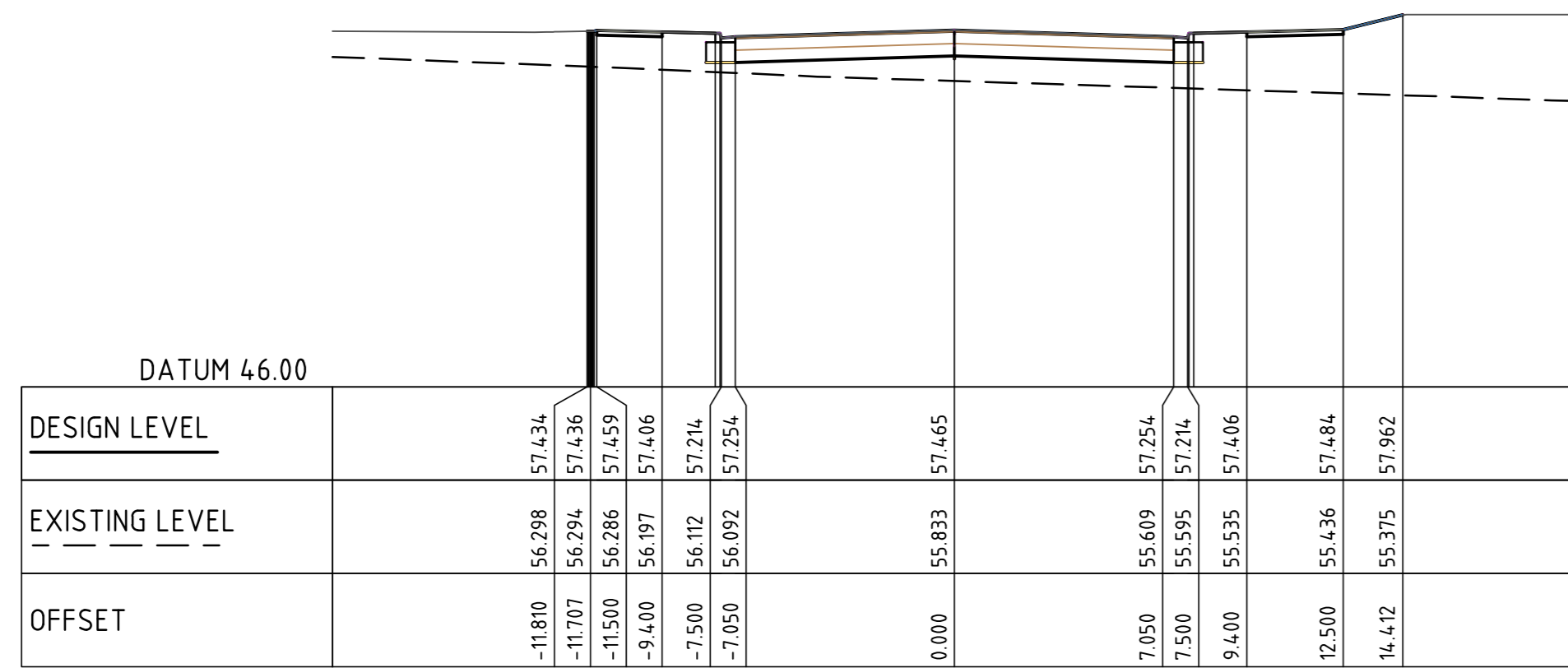

CL IND RD 1
CH 260.000
SCALE 1:200

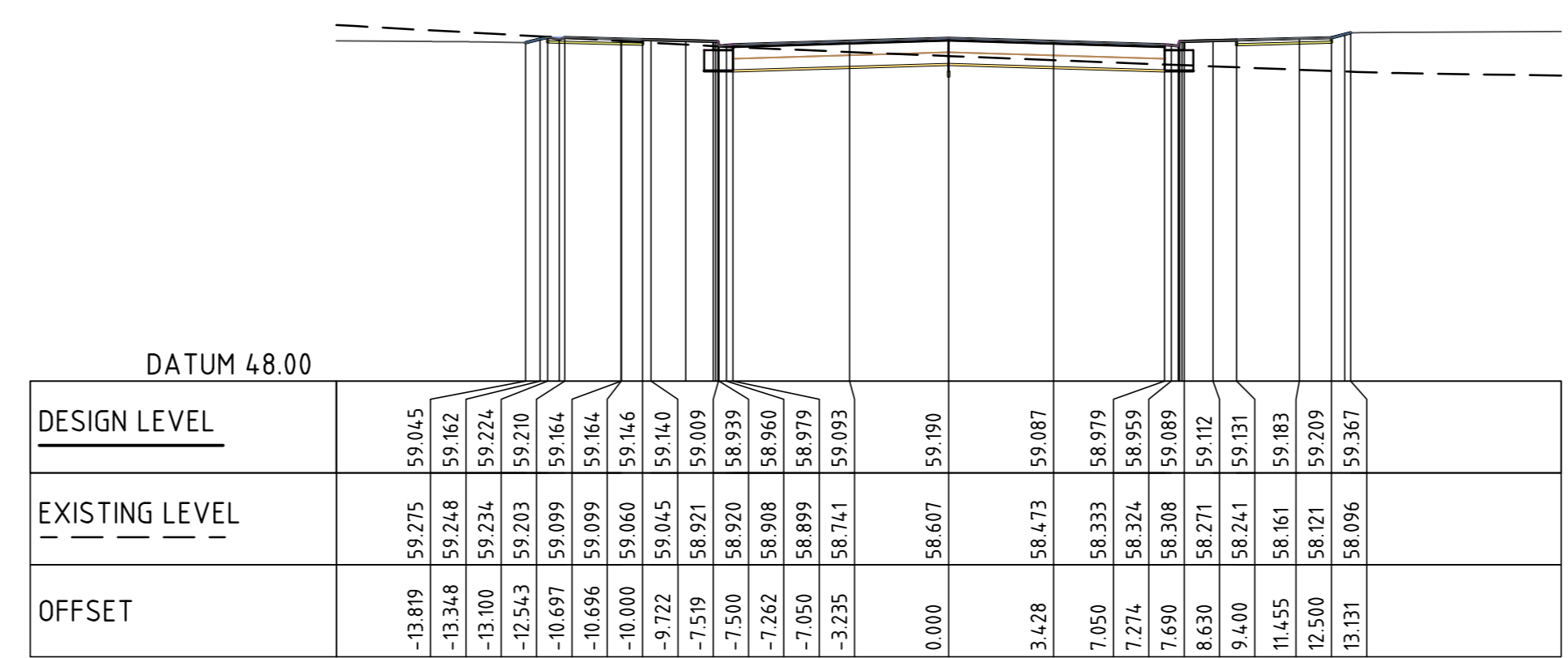

CL IND RD 1
CH 340.000
SCALE 1:200

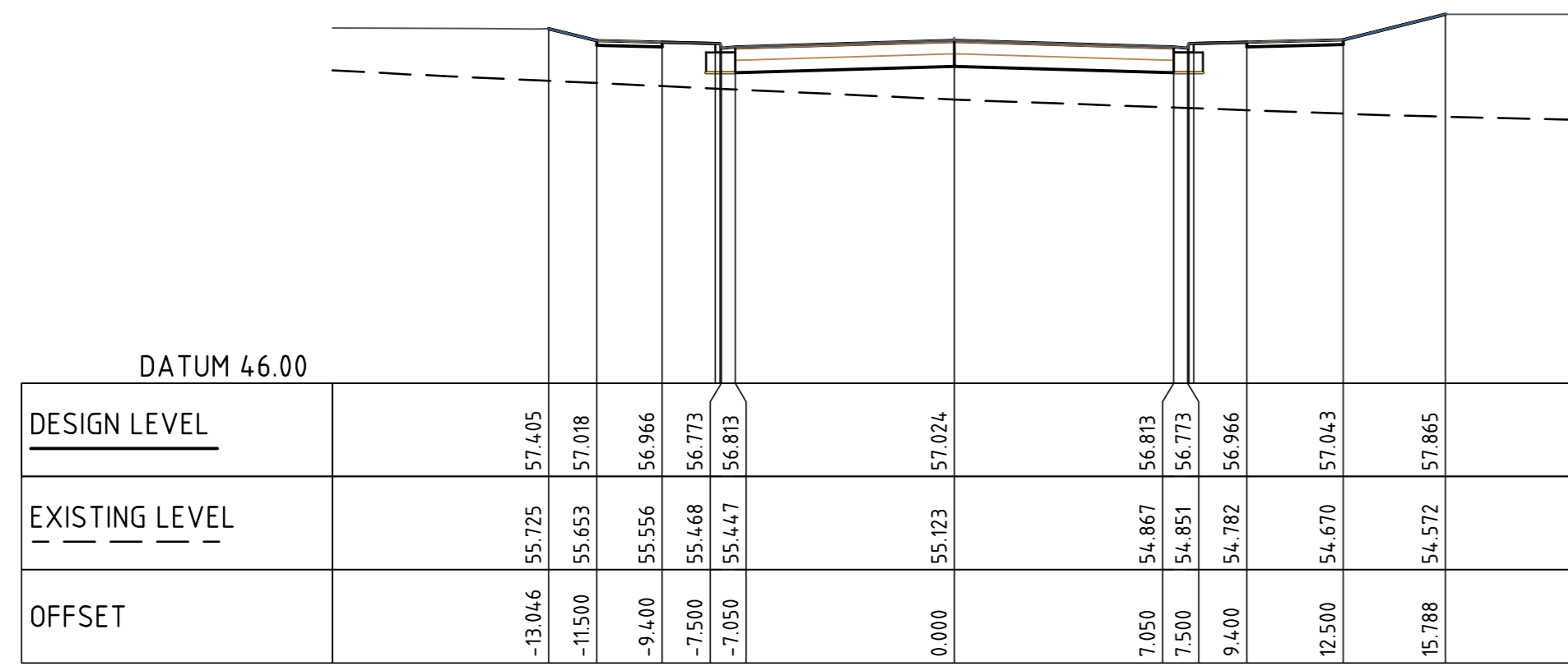

CL IND RD 1
CH 240.000
SCALE 1:200

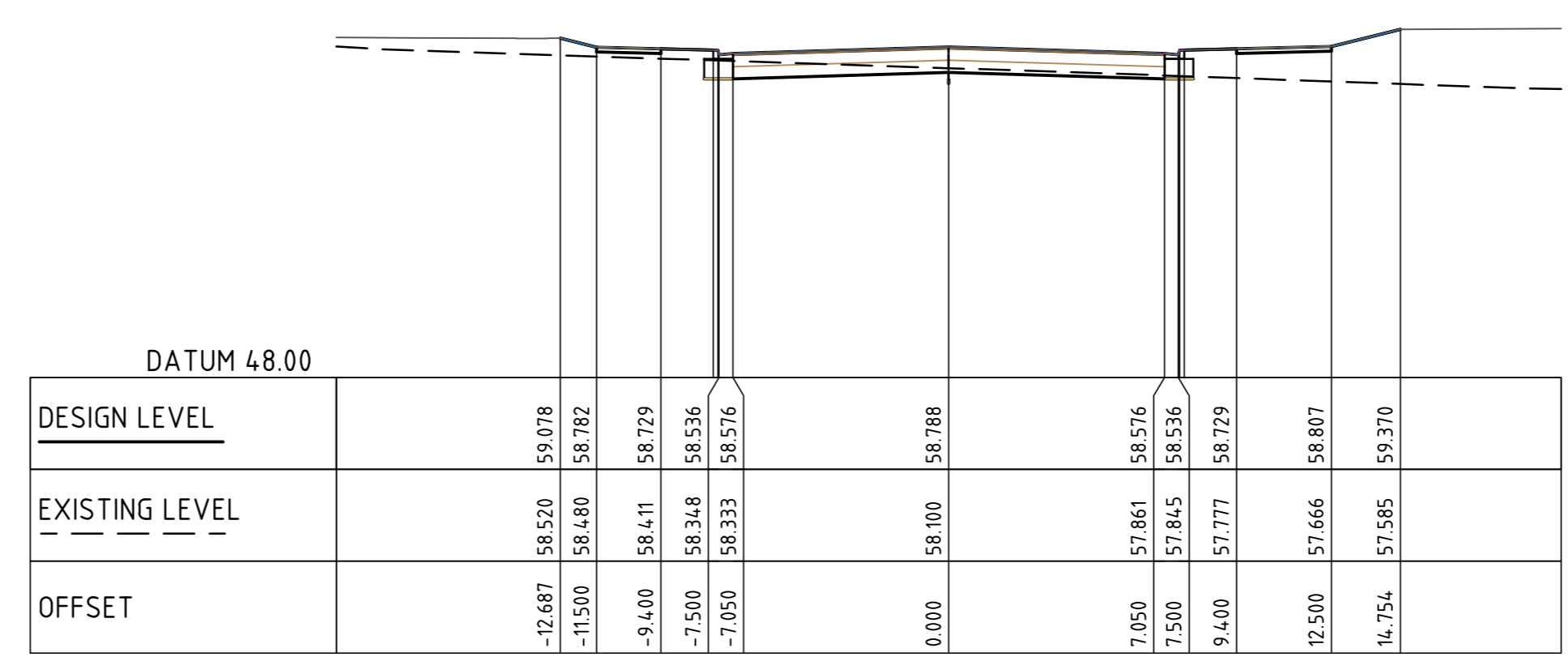

CL IND RD 1
CH 320.000
SCALE 1:200

PROPOSED ESTATE SURFACE (TYP)

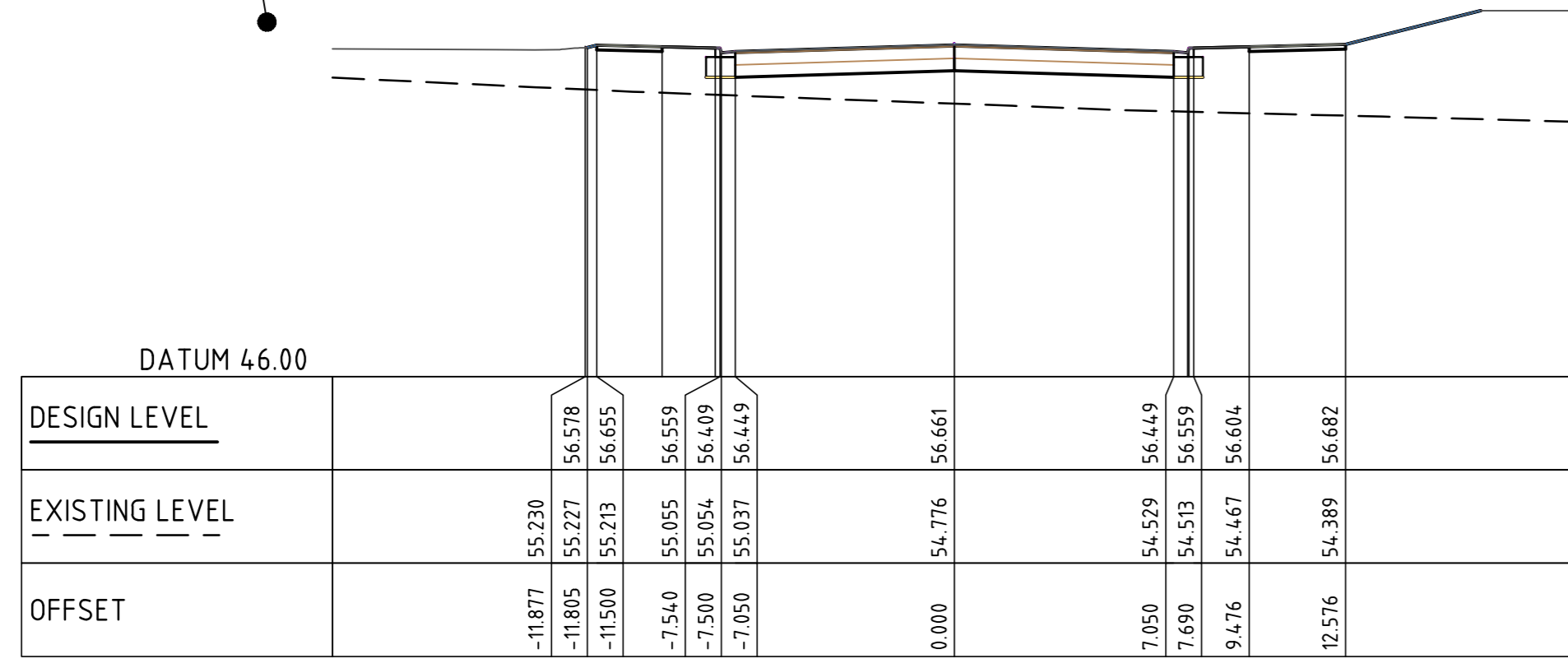

CL IND RD 1
CH 220.000
SCALE 1:200

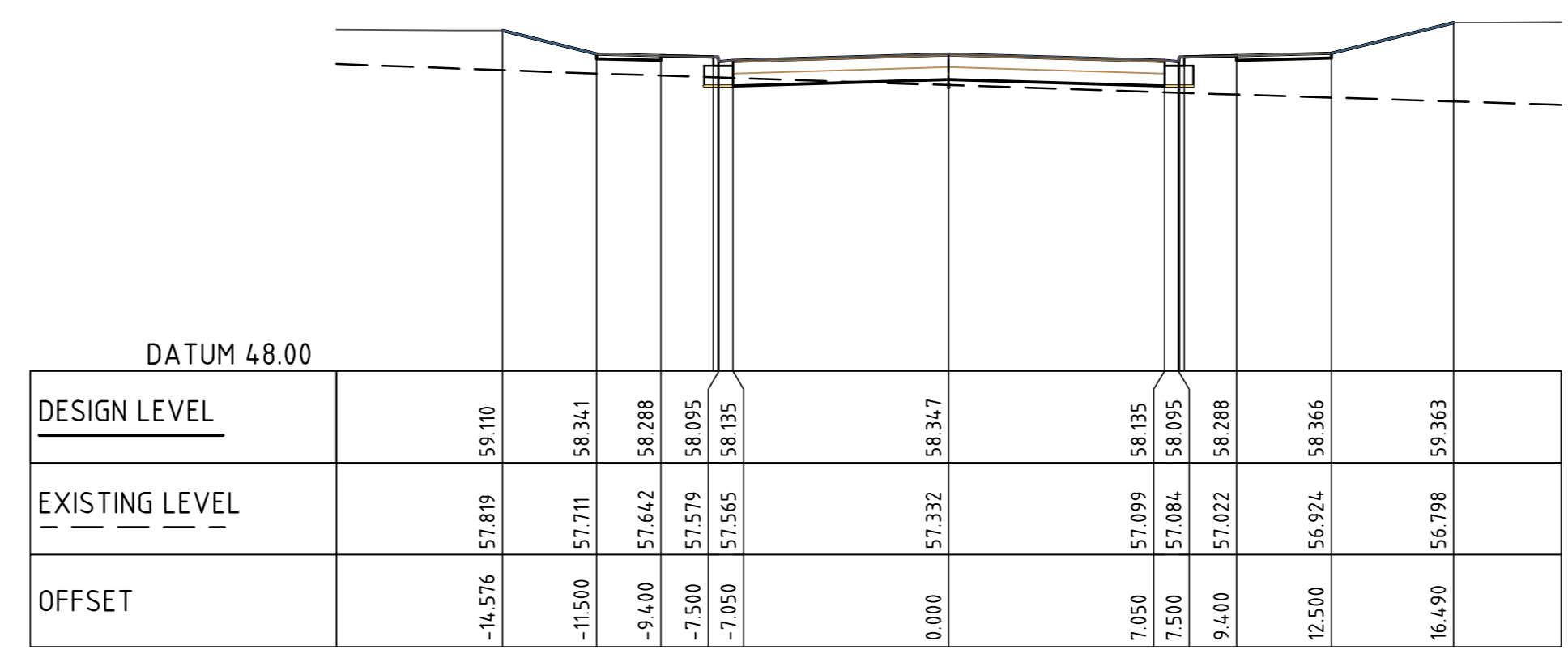

CL IND RD 1
CH 300.000
SCALE 1:200

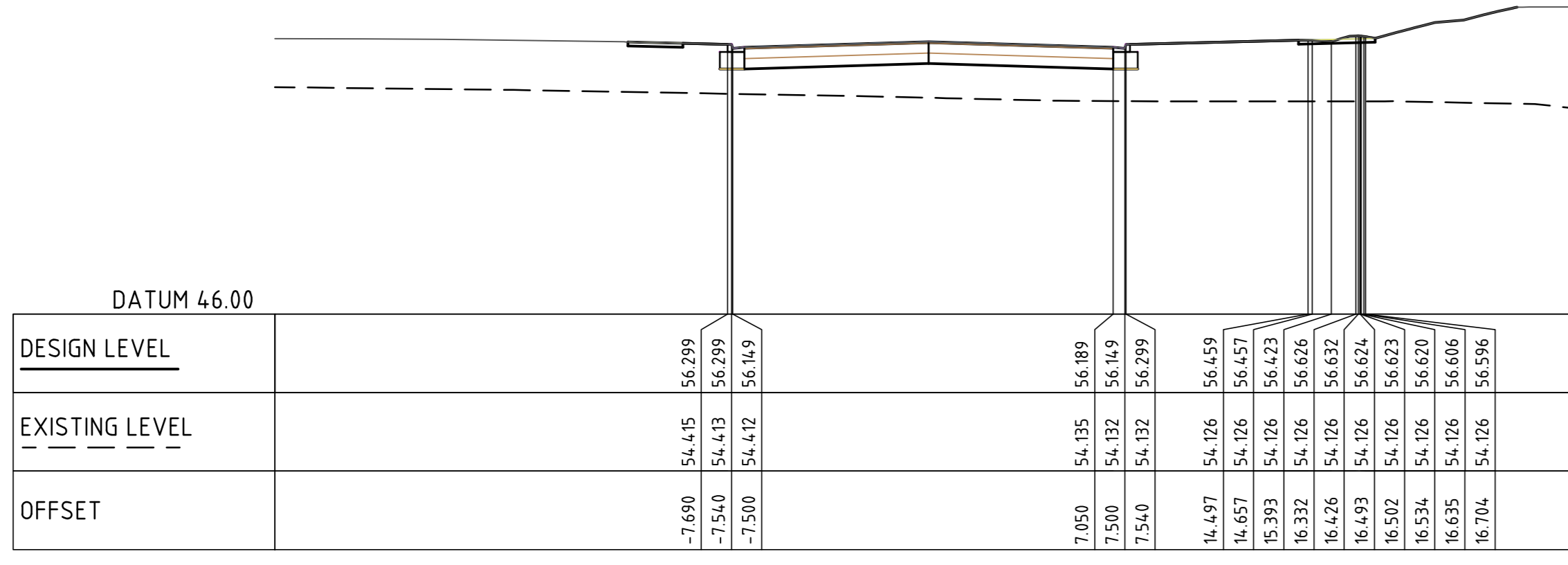

CL IND RD 1
CH 200.000
SCALE 1:200

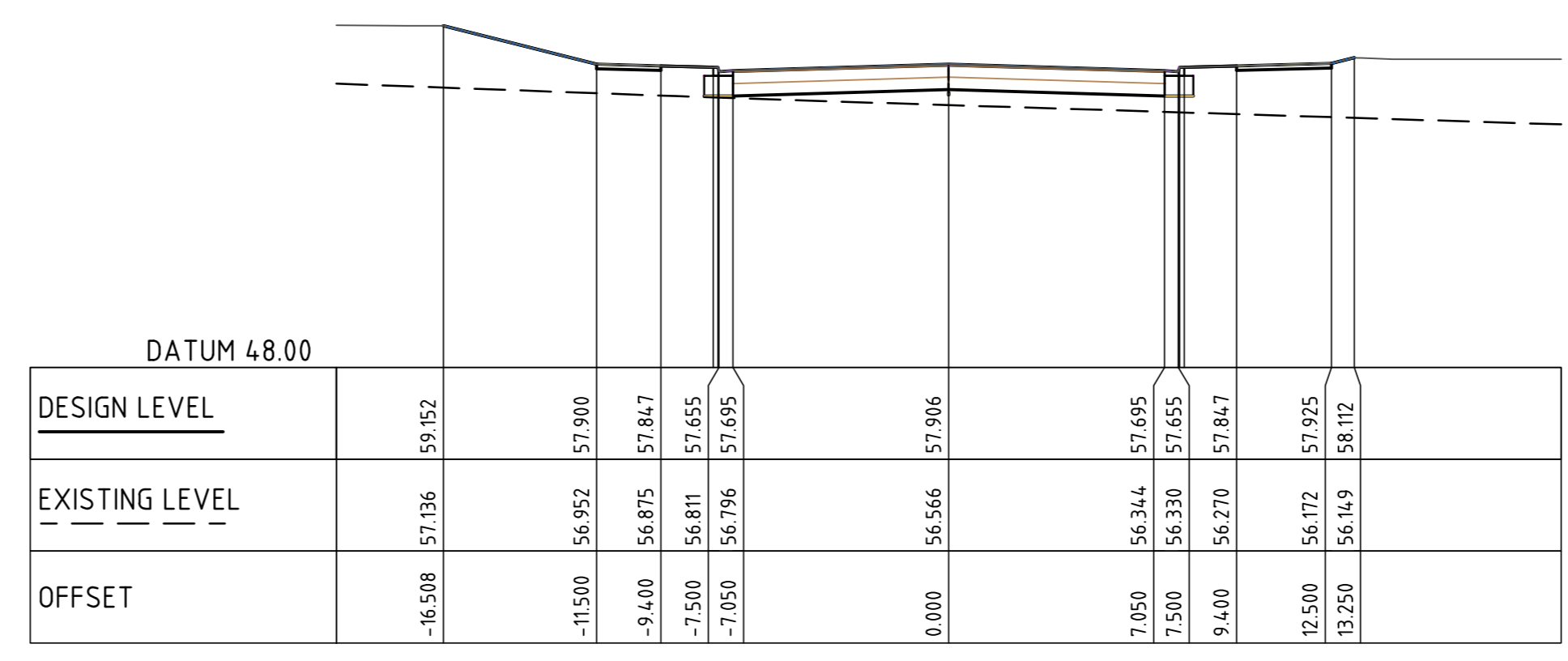

CL IND RD 1
CH 280.000
SCALE 1:200

FOR SWC-3

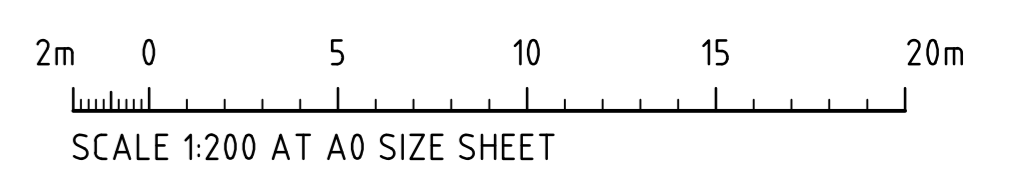

ISSUED FOR	DATE	ISSUE	AMENDMENTS
ISSUED FOR SWC-3	21.02.25	3	
ISSUED FOR CONSTRUCTION	24.07.24	2	
ISSUED FOR CONSTRUCTION	08.05.24	1	
ISSUED FOR CONSTRUCTION	02.05.24	0	
ISSUED FOR PRELIMINARY ONLY	15.03.24	A	

PROJECT MANAGER
ProjectStrategy

ARCHITECT
nettleton|tbe

CLIENT
BURTON
Civil Engineering Contractors

PROJECT
ACCESS LOGISTICS PARK
884-928 MAMRE ROAD
KEMPS CREEK, NSW

CONSULT AUSTRALIA

Costin Roe Consulting Pty Ltd.
ABN 50 003 696 446
PO Box 7419 Sydney NSW 1220
Level 4, 4 Woodmill Street, Milsons Point NSW 2000
p: +61 2 9251 7699 e: +61 2 9241 3731
w: costinroe.com.au

CRC
COSTIN ROE CONSULTING
CIVIL & STRUCTURAL ENGINEERS

DRAWING TITLE
ROADWORKS SECTIONS SHEET 5
DRAWING No **C014021.05-C565** ISSUE **3**

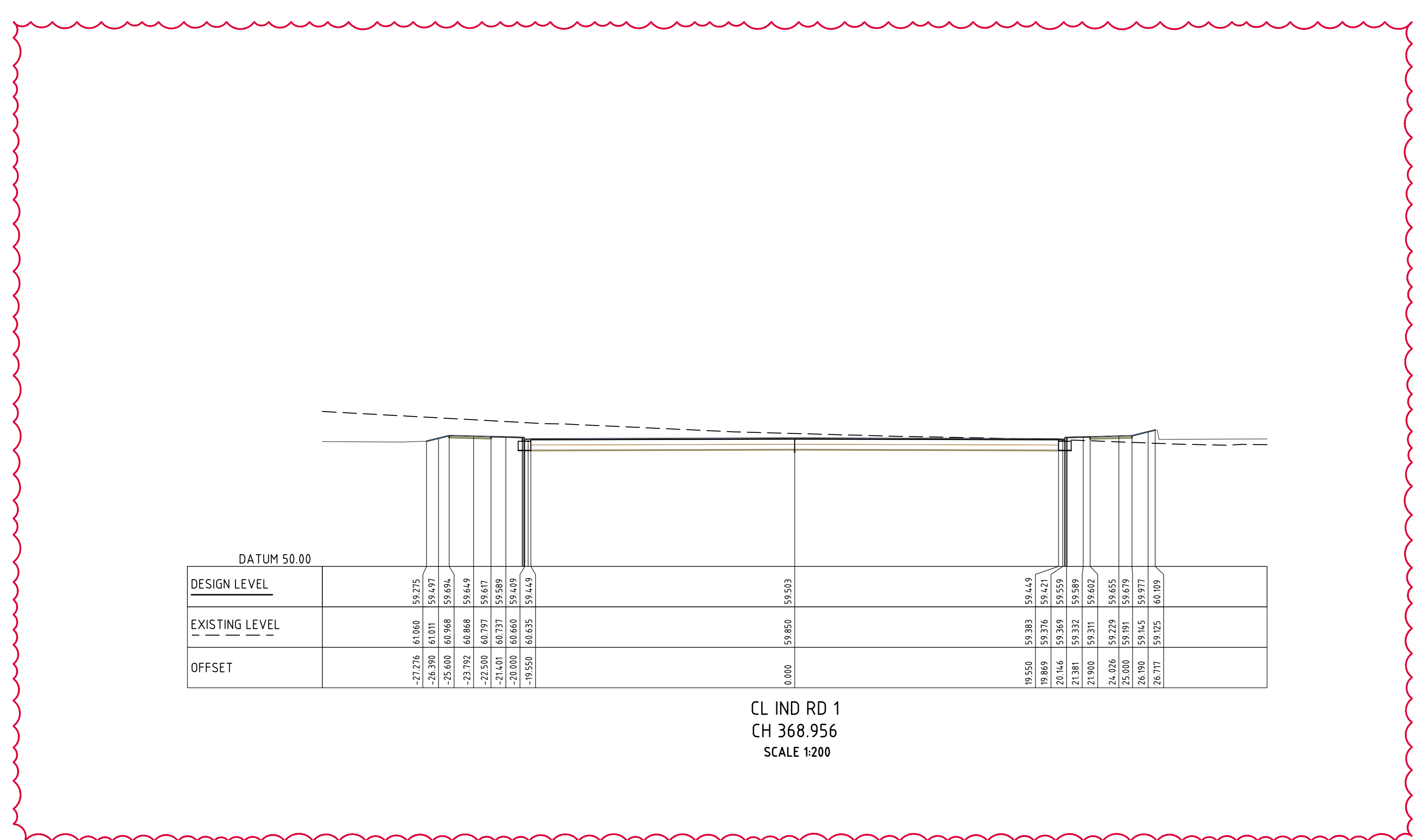

HOLD

FOR SWC-3

ISSUED FOR SWC-3	21.02.25	3
ISSUED FOR CONSTRUCTION	26.07.24	2
ISSUED FOR CONSTRUCTION	08.05.24	1
ISSUED FOR CONSTRUCTION	02.05.24	0
ISSUED FOR PRELIMINARY ONLY	15.03.24	A
AMENDMENTS	DATE	ISSUE

PROJECT MANAGER

ARCHITECT

CLIENT

PROJECT
ACCESS LOGISTICS PARK
 884-928 MAMRE ROAD
 KEMPS CREEK, NSW

Costin Roe Consulting Pty Ltd.
 ABN 50 003 696 446
 PO Box 1419 Sydney NSW 1520
 Level 4, 8 Windmill Street, Millers Point NSW 2000
 p: +61 2 9251 7699 f: +61 2 9241 3751
 e: mail@costinroe.com.au w: costinroe.com.au

DRAWING TITLE
ROADWORKS SECTIONS
 SHEET 6

DRAWING No **C014021.05-C566** ISSUE **3**

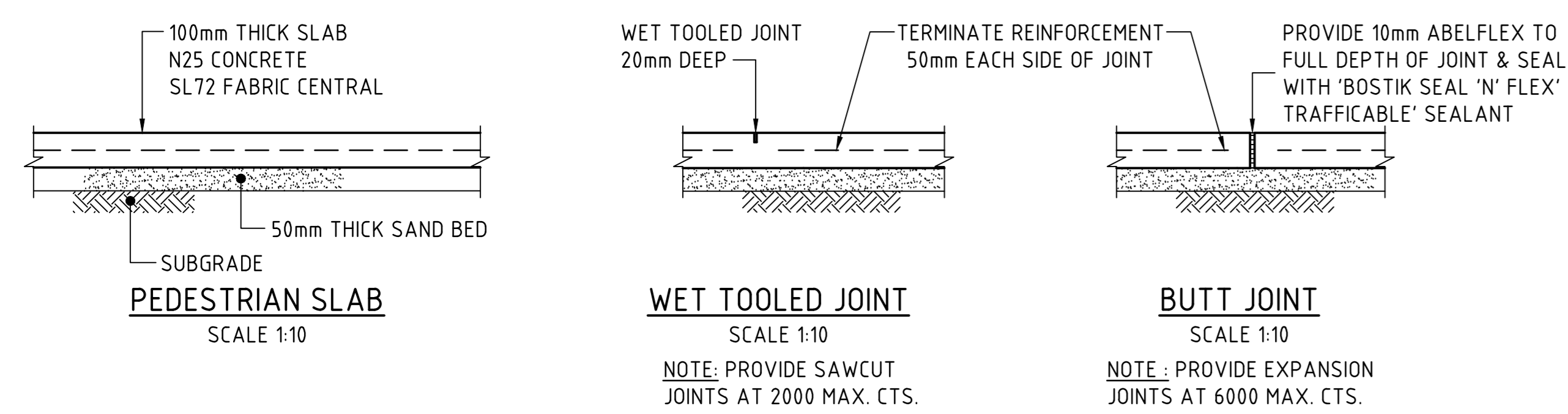
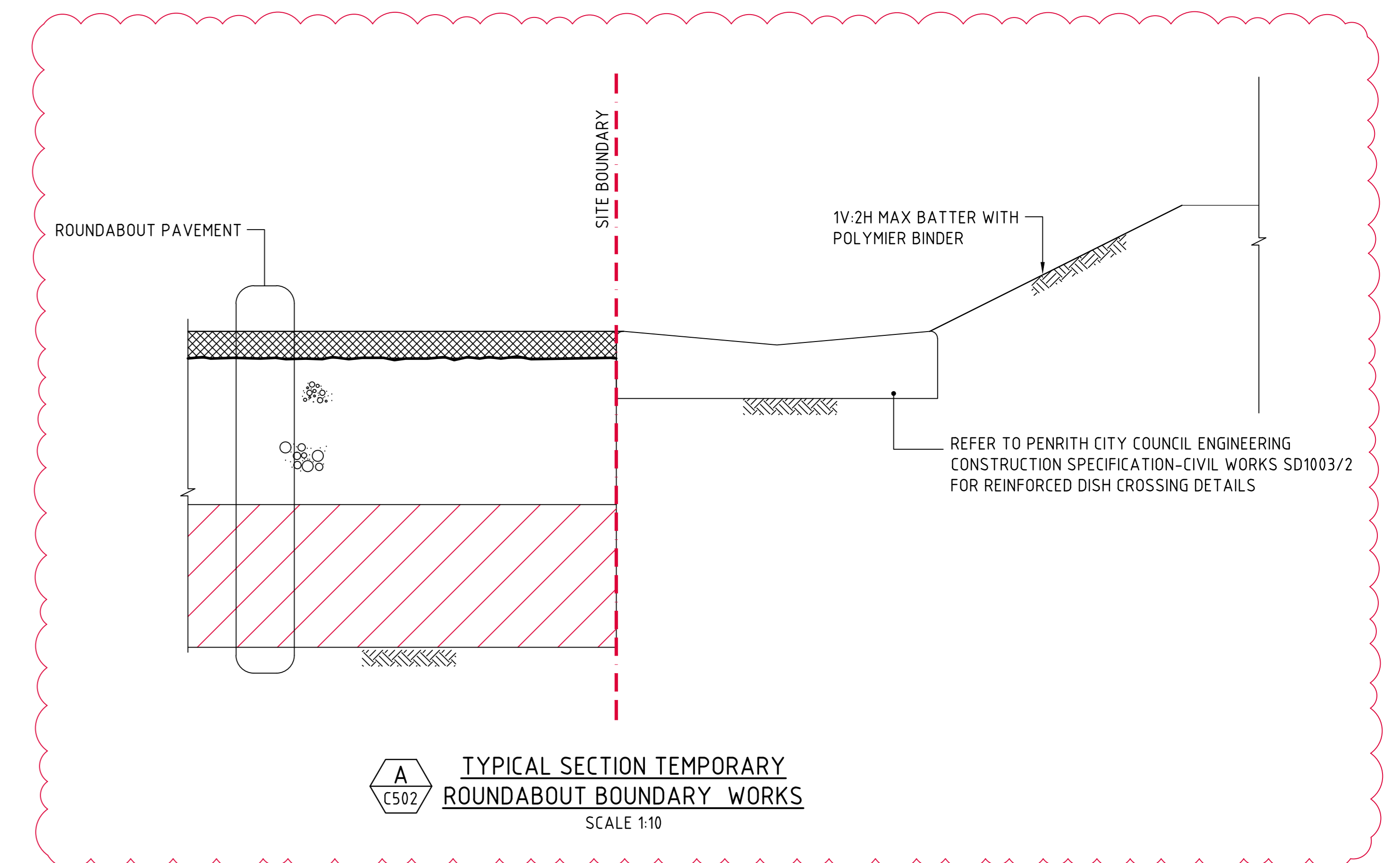
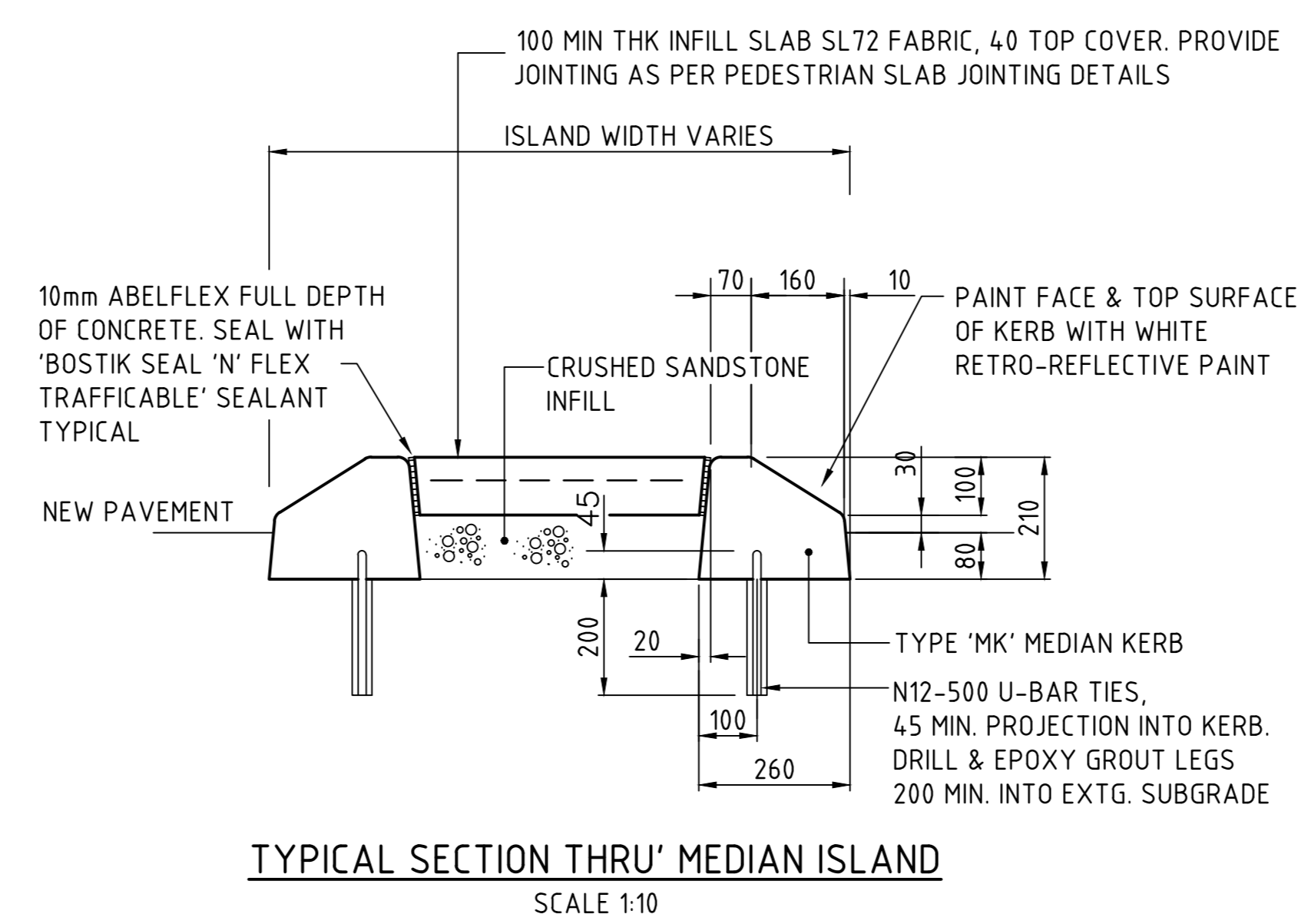
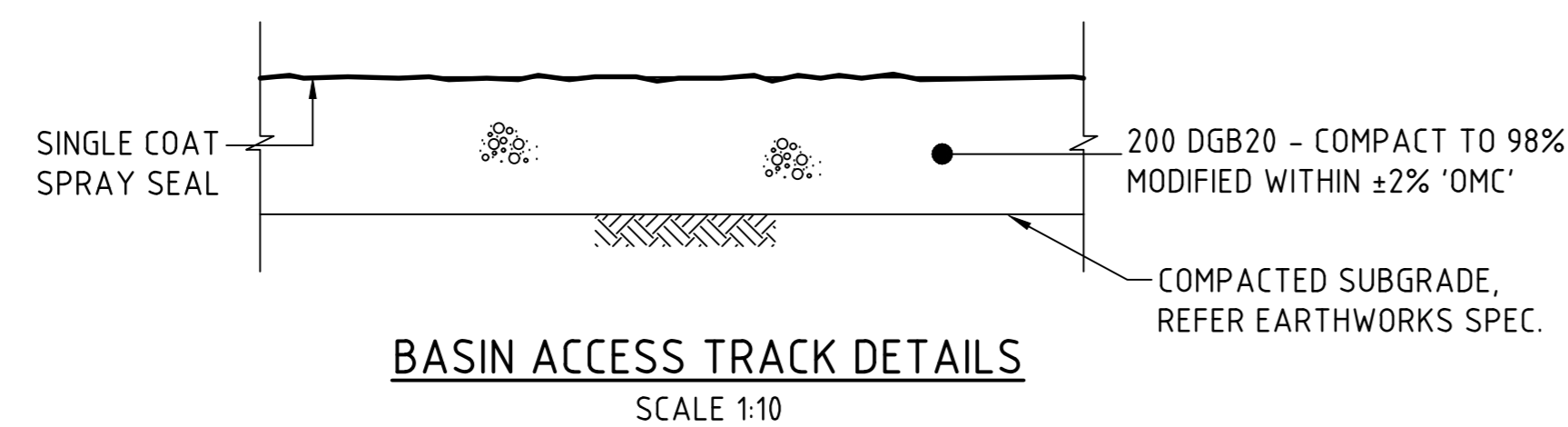
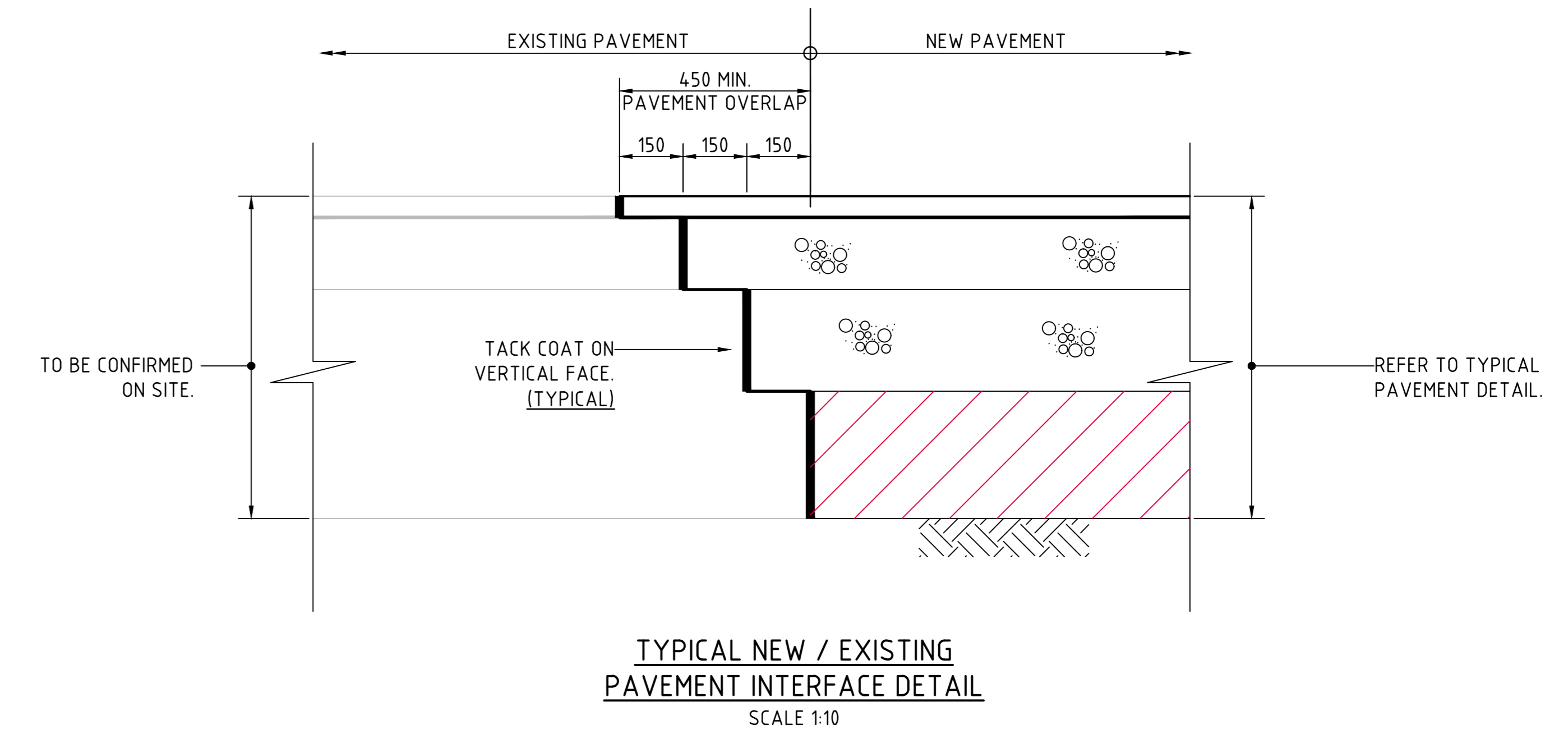
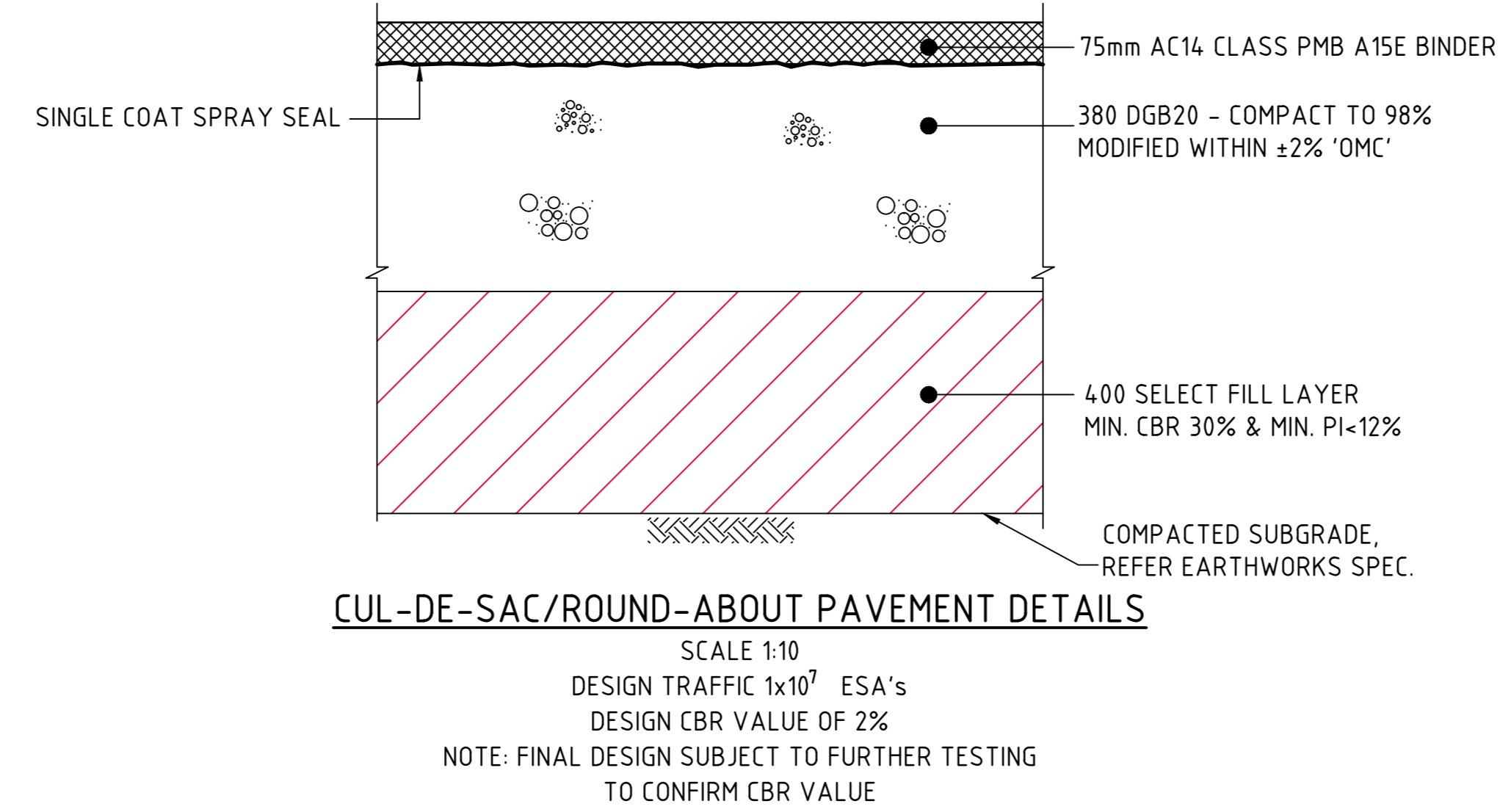
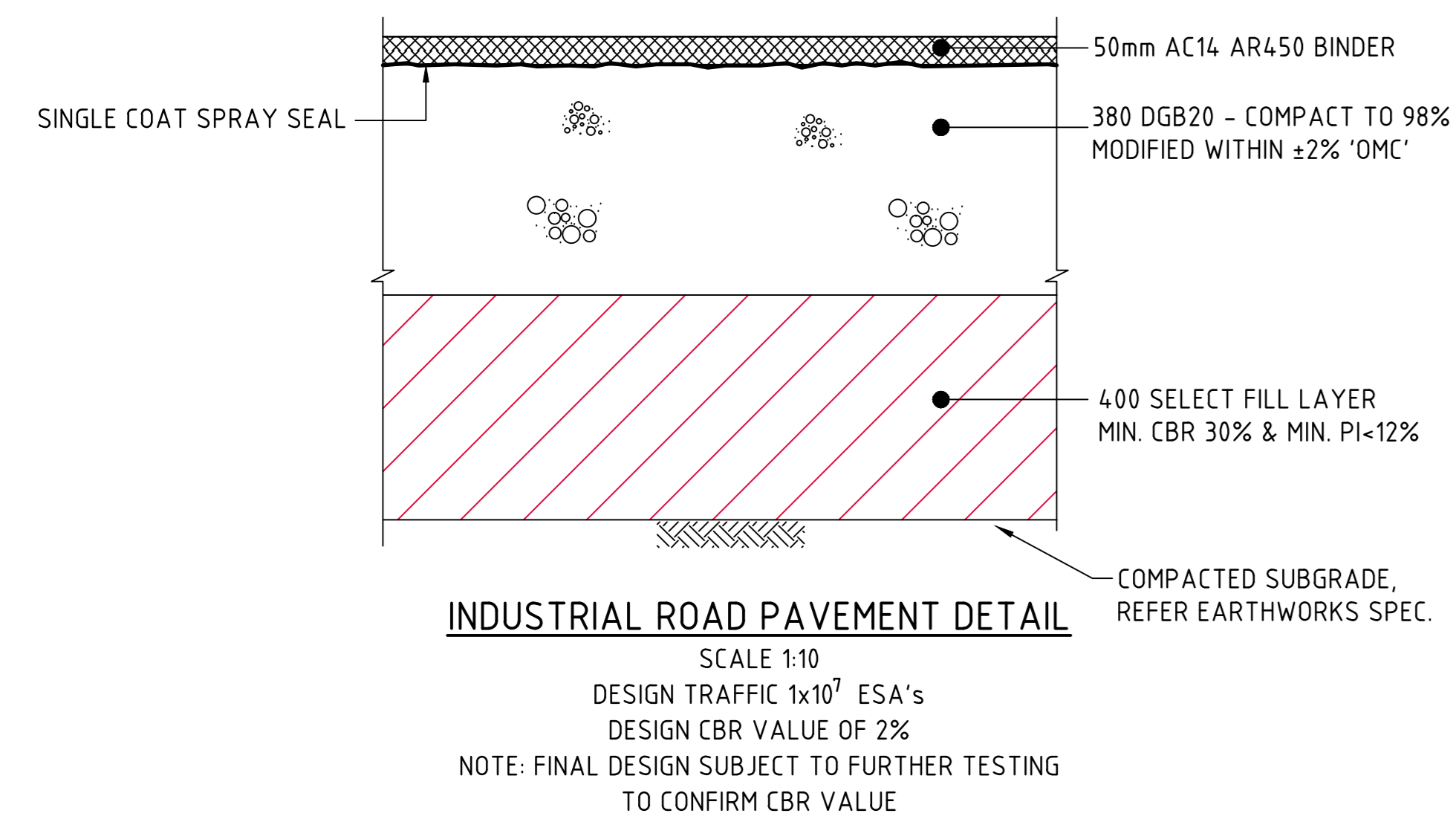

PEDESTRIAN SLAB DETAILS

TYPICAL SECTION THRU MEDIAN ISLAND

TYPICAL SECTION TEMPORARY ROUNDABOUT BOUNDARY WORKS

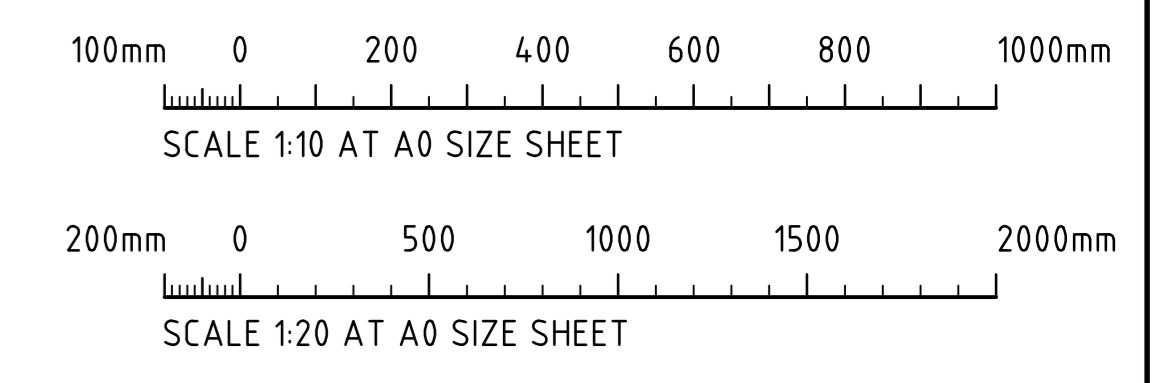
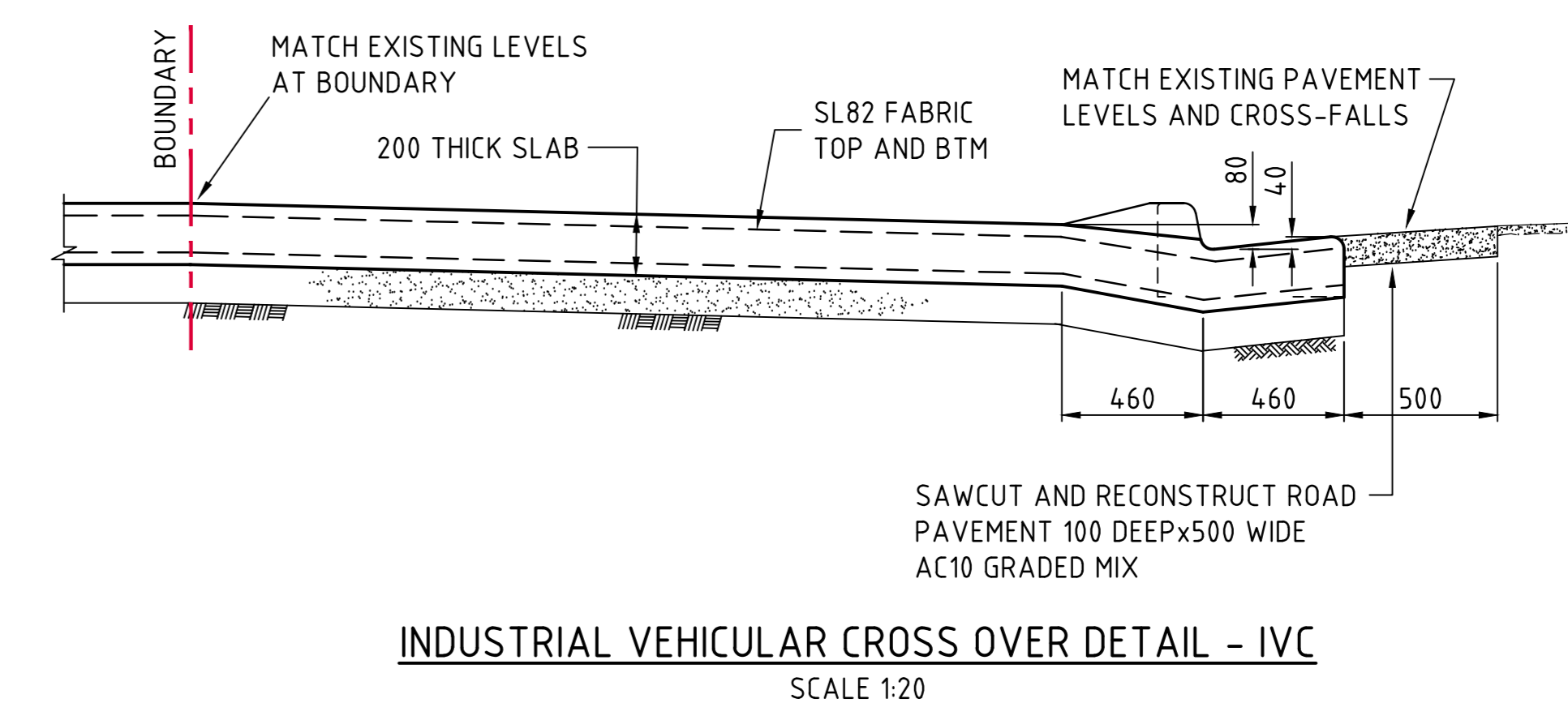
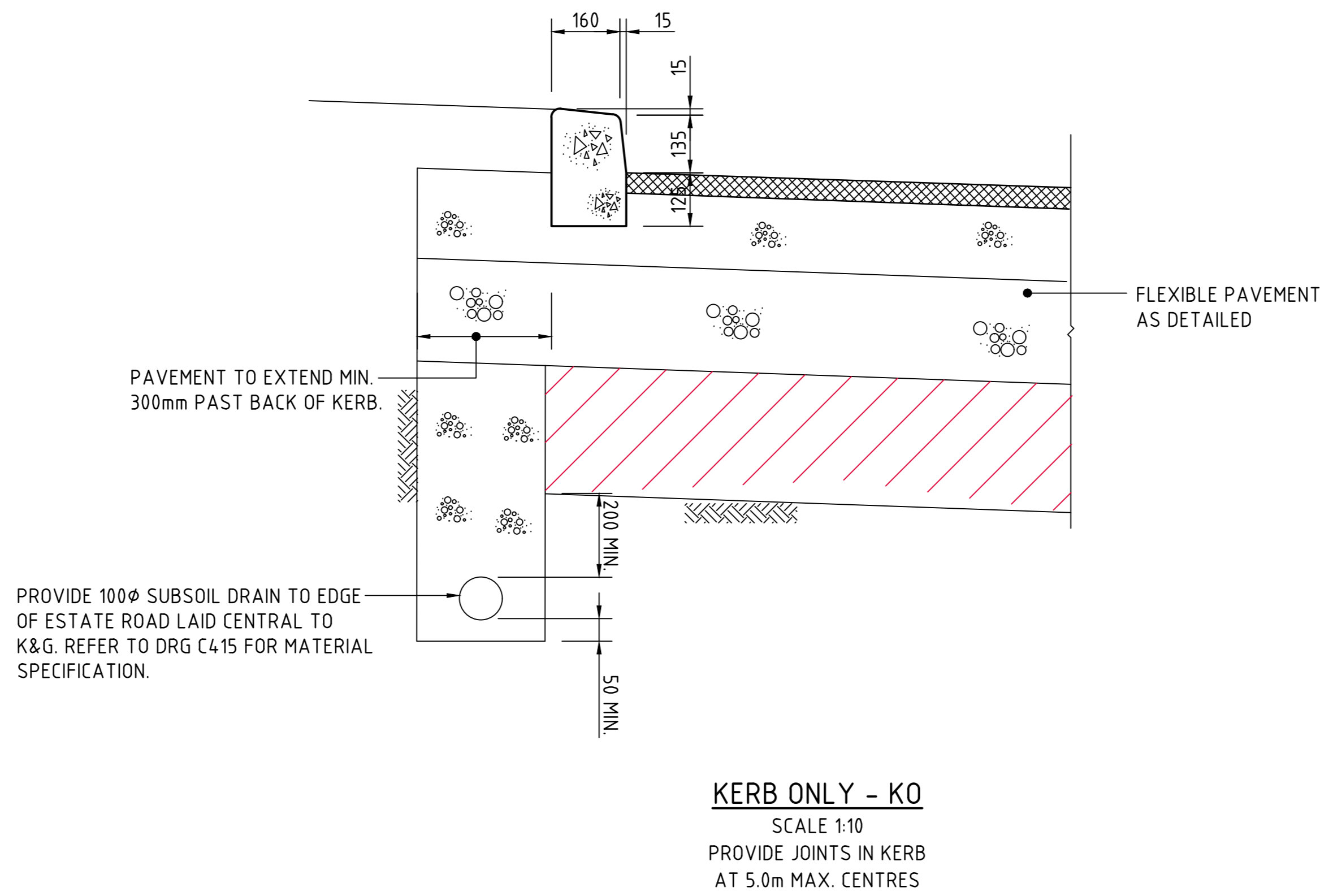
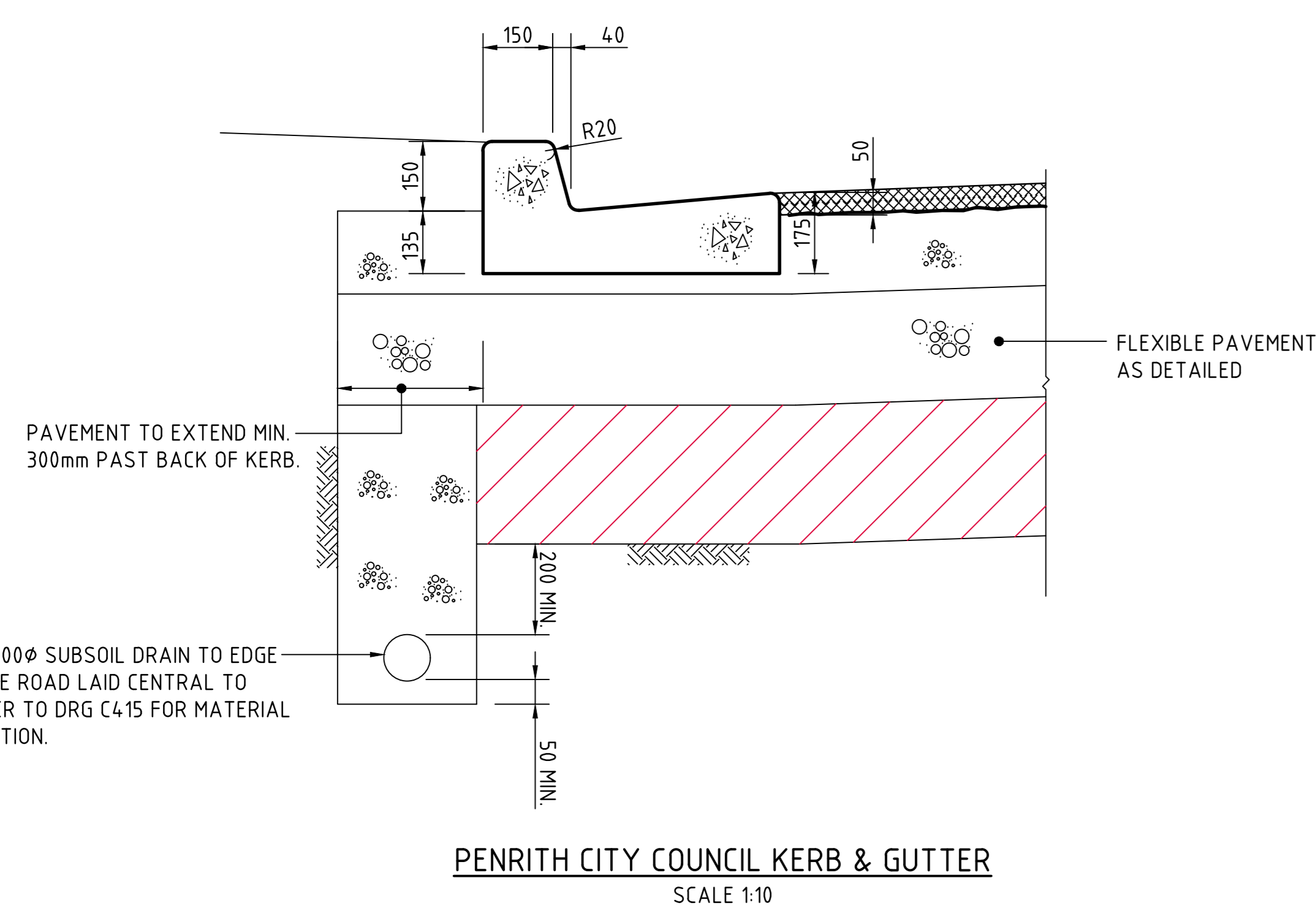

FOR SWC-3

ISSUED FOR	DATE	ISSUE	AMENDMENTS	DATE	ISSUE	AMENDMENTS
ISSUED FOR SWC-3	03.03.25	3				
ISSUED FOR SWC-3	21.02.25	2				
ISSUED FOR CONSTRUCTION	24.07.24	1				
ISSUED FOR CONSTRUCTION	02.05.24	0				
ISSUED FOR PRELIMINARY ONLY	15.03.24	A				

PROJECT MANAGER: **ProjectStrategy**
ARCHITECT: **nettleton|tibe**
CLIENT: **BURTON Civil Engineering Contractors**

PROJECT: **ACCESS LOGISTICS PARK**
884-928 MAMRE ROAD
KEMPS CREEK, NSW
DESIGNED: DW | DRAWN: [] | DATE: [] | CHECKED: MW | SIZE: A0 | SCALE: AS SHOWN | CAD REF: C01402105-C 570

CONSULT: **AUSTRALIA**
Costin Roe Consulting Pty Ltd.
ABN 50 003 696 446
PO Box 9419 Sydney NSW 1520
Level 4, 4 Woodruff Street, Mollies Point NSW 2000
p: +61 2 9251 7699 | e: +61 2 9241 3731
e: mail@costinroe.com.au | w: costinroe.com.au

CRC COSTIN ROE CONSULTING | **CIVIL & STRUCTURAL ENGINEERS**

DRAWING TITLE: **ROADWORKS DETAILS**
DRAWING No: **C014021.05-C570** | ISSUE: **3**

