

Bingo Recycling Ecology Park

Eastern Creek

Landscape Development Application

© 2021 Site Image (NSW) Pty Ltd ABN 44 801 262 380 as agent for Site Image NSW Partnership. All rights reserved. This drawing is copyright and shall not be reproduced or copied in any form or by any means (graphic, electronic or mechanical including photocopy) without the written permission of Site Image (NSW) Pty Ltd. Any license, expressed or implied, to use this document for any purpose what so ever is restricted to the terms of the written agreement between Site Image (NSW) Pty Ltd and the instructing party.

The contractor shall check and verify all work on site (including work by others) before commencing the landscape installation. Any discrepancies are to be reported to the Project Manager or Landscape Architect prior to commencing work. Do not scale this drawing. Any required dimensions not shown shall be referred to the Landscape Architect for confirmation.

Drawing Schedule

Drawing Number	Drawing Title	Scale
000	Landscape Coversheet	N/A
101	Landscape Plan 1	1:200
102	Landscape Plan 2	1:200
103	Landscape Plan 3	1:250
104	Landscape Plan 4	1:250
105	Landscape Plan 5	1:250
106	Landscape Plan 6	1:250
107	Landscape Plan 7	1:250
108	Landscape Plan 8	1:250
501	Landscape Details	As Shown

Plant Schedule

Botanic Name	Common Name	Mature Size	Pot Size	Spacing	CPW
TREES					
Ai <i>Acacia implexa</i>	Hickory Wattle	8 x 7	100L	As Shown	
Ef <i>Eucalyptus fibrosa</i>	Red Ironbark	30 x 5	100L	As Shown	
Em <i>Eucalyptus moluccana</i>	Grey Box	25 x 7	100L	As Shown	
Md <i>Melaleuca decora</i>	White Feather Honey Myrtle	8 x 4	100L	As Shown	
SHRUBS AND ACCENTS					
Cs <i>Cheilanthes sieberi</i>	Poison Rock Fern	0.6 x 0.4	300mm	As Shown	
Du <i>Daviesia ulicifolia</i>	Gorse Bitter-pea	2 x 1	300mm	As Shown	
Ds <i>Dillwynia sieberi</i>	Siebers Parrot-pea	1 x 1	300mm	As Shown	
Ia <i>Indigofera australis</i>	Austral Indigo	2 x 2	300mm	As Shown	
GROUNDCOVERS AND GRASSES					
Lf <i>Lomandra filiformis</i>	Wattle Mat-rush	0.5 x 0.3	150mm	5/m2	
Ta <i>Themeda australis</i>	Kangaroo Grass	1.5 x 1	150mm	5/m2	
Hv <i>Hardenbergia violacea</i>	Native Sarsaparilla	0.3 x 1.5	150mm	5/m2	
PLANTING MATRIX 1 (7SqM Mixed Species)					
GROUNDCOVERS AND GRASSES					
<i>Aristida ramosa</i>	Purple Wire Grass	1 x 0.6	tube		
<i>Arthropodium milleflorum</i>	Vanilla Lily	0.6 x 0.3	tube		
<i>Asperula conferta</i>	Common Woodruff	0.3 x 0.5	tube		
<i>Brunoniella australis</i>	Blue Trumpet	0.3 x 0.3	tube	7/Sqm	mixed species
<i>Chloris truncata</i>	Australian Fingergrass	0.5 x 0.4	tube		
<i>Chloris ventricosa</i>	Tall Chloris	0.4 x 0.3	tube		
<i>Dichelachne micrantha</i>	Shorthair Plumegrass	0.3 x 0.3	tube		
<i>Dichondra repens</i>	Kidney Weed	0.15 x spreading	tube		
PLANTING MATRIX 2 (5SqM Mixed Species)					
SCREENING PLANTING					
<i>Acacia binervata</i>	Coastal Wattle	4 x 4	300mm		
<i>Acacia decurrens</i>	Sydney Golden Wattle	4 x 4	300mm		
<i>Dillwynia sieberi</i>	Prickly Parrot-pea	2 x 1	300mm		
<i>Indigofera australis</i>	Austral indigo	3 x 1.5	300mm	5/Sqm	mixed species
<i>Lepidosperma laterale</i>	Variable swordssedge	1.5 x 0.5	300mm		
<i>Lomandra nibbertia</i>	Mat Rush	0.5 x 0.6	300mm		
<i>Dianella longifolia</i>	Smooth-leaved Flax Lily	1.5 x 1	300mm		
<i>Eremophila debilis</i>	Winter apple	2 x 1	300mm		
PLANTING MATRIX 3 (5SqM Mixed Species)					
CASCADING PLANTING					
<i>Dianella longifolia</i>	Blue Flax-lily	0.8 x 0.5	300mm		
<i>Hibbertia diffusa</i>	Wedge Guinea Flower	0.3 x 1 spreading	300mm	5/Sqm	mixed species
<i>Hardenbergia violacea</i>	Native Sarsaparilla	0.3 x spreading	300mm		
<i>Lomandra multiflora</i>	Mat Rush	0.5 x 0.5	300mm		
<i>Lomandra filiformis subsp. Filiformis</i>	Mat Rush	0.2 x 0.2	300mm		

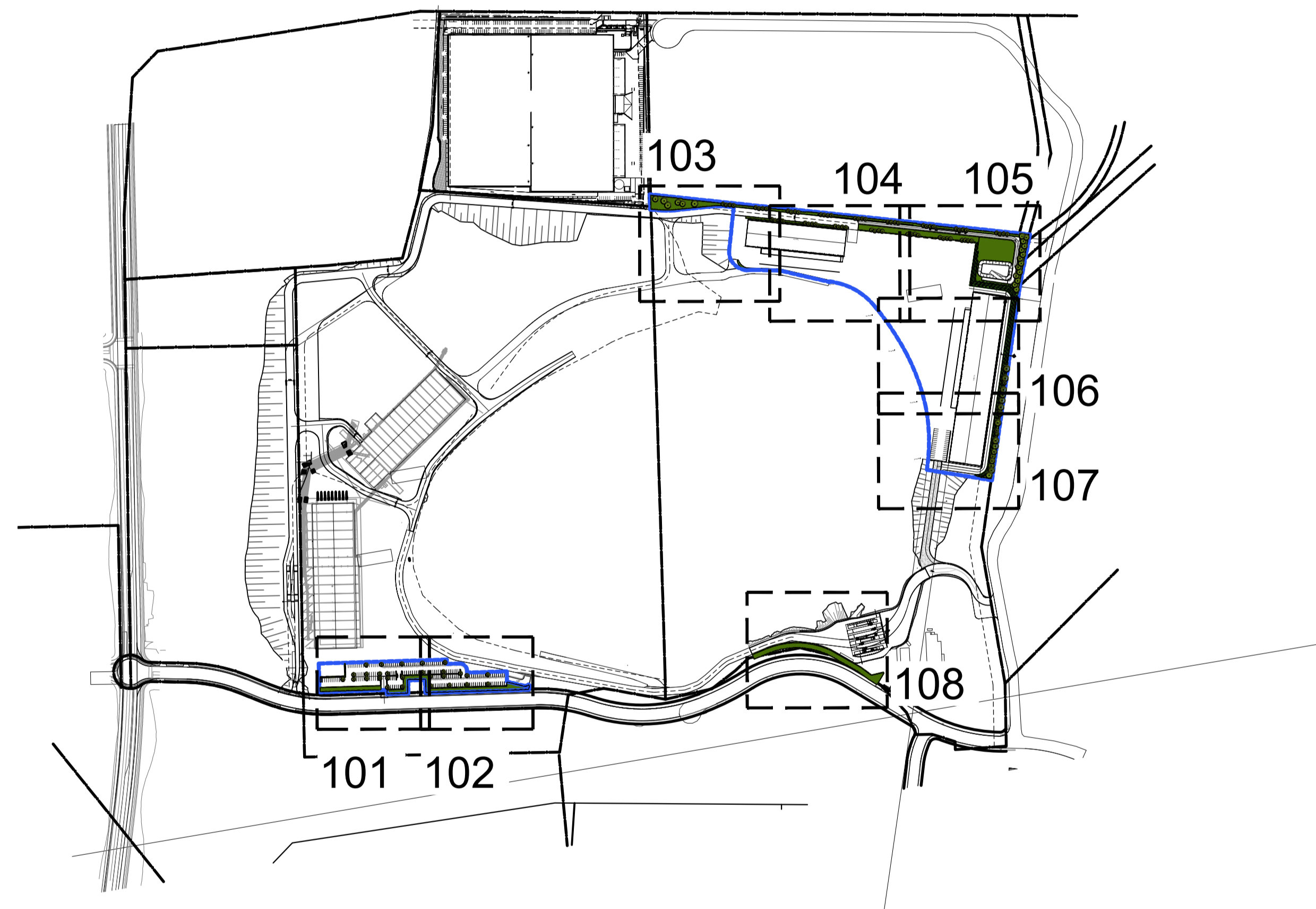

Key Plan 1:5000 @ A1

Issue	Revision Description	Drawn	Check	Date
G	Response to Comments	VF	NM	13.06.2025
F	Response to Comments	LH	NM	29.06.2024
E	Civil Coordination	JD	NM	24.05.2023
D	Civil Coordination	SJ	NM	02.05.2023
C	Carpark Trees Added	JD	NM	29.04.2022
B	Development Application	MW	NM	01.02.2022
A	Masterplan Thoughtput	JD	NM	17.07.2021

Client:
IRM Property Group (No2)

Project:
Bingo Recycling Ecology Park Eastern Creek

SITE IMAGE
Level 1, 3-5 Baptist Street
Redfern NSW 2016
Australia
Tel: (61 2) 8332 5600
Fax: (61 2) 9698 2877
www.siteimage.com.au
Site Image (NSW) Pty Ltd
ABN 44 801 262 380
Landscape Architects

SSD Application
Drawing Name:
Landscape Coversheet

Scale:
Job Number: SS20-4531
Drawing Number: 000
Issue: G

NOT FOR CONSTRUCTION

© 2021 Site Image (NSW) Pty Ltd ABN 44 801 262 380 as agent for Site Image NSW Partnership. All rights reserved. This drawing is copyright and shall not be reproduced or copied in any form or by any means (graphic, electronic or mechanical including photocopy) without the written permission of Site Image (NSW) Pty Ltd. Any license, expressed or implied, to use this document for any purpose whatsoever is restricted to the terms of the written agreement between Site Image (NSW) Pty Ltd and the instructing party.

The contractor shall check and verify all work on site (including work by others) before commencing the landscape installation. Any discrepancies are to be reported to the Project Manager or Landscape Architect prior to commencing work. Do not scale this drawing. Any required dimensions not shown shall be referred to the Landscape Architect for confirmation.

Issue	Revision Description	Drawn	Check	Date
F	Response to Comments	VF	NM	13.06.2025
E	Civil Coordination	JD	NM	24.05.2023
D	Civil Coordination	SJ	NM	02.05.2023
C	Carpark Trees Added	JD	NM	23.04.2022
B	Development Application	MW	NM	01.02.2022
A	Masterplan Thoughtput	JD	NM	17.07.2021

- LEGEND**
- Extent of Works
 - Proposed Tree (Refer Plant Schedule & Detail)
 - Grasses & Groundcovers (Refer Plant Schedule & Detail)
 - Planting Matrix 1 (Grasses and Groundcovers)
 - Planting Matrix 2 (Screening Planting)
 - Planting Matrix 3 (Cascading planting)



For continuation refer 102

Client:
IRM Property Group (No2)

Project:
Bingo Recycling
Ecology Park
Eastern Creek

SITE IMAGE
Level 1, 3-5 Baptist Street
Redfern NSW 2016
Australia
Tel: (61 2) 8332 5600
Fax: (61 2) 9698 2877
www.siteimage.com.au
Site Image (NSW) Pty Ltd
ABN 44 801 262 380
Landscape Architects





SSD Application
Drawing Name:
Landscape Plan - 1

Scale: 1:200 @ A1
Job Number: SS20-4531
Drawing Number: 101
Issue: F

NOT FOR CONSTRUCTION

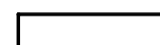
The contractor shall check and verify all work on site (including work by others) before commencing the landscape installation. Any discrepancies are to be reported to the Project Manager or Landscape Architect prior to commencing work. Do not scale this drawing. Any required dimensions not shown shall be referred to the Landscape Architect for confirmation.

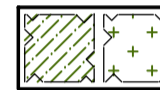
Issue	Revision Description	Drawn	Check	Date
F	Response to Comments	VF	NM	13.06.2025
E	Civil Coordination	JD	NM	24.05.2023
D	Civil Coordination	SJ	NM	02.05.2023
C	Carpark Trees Added	JD	NM	23.04.2022
B	Development Application	MW	NM	01.02.2022
A	Masterplan Thoughtput	JD	NM	17.07.2021

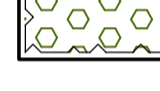
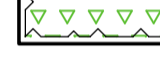
- LEGEND**
-  Extent of Works
 -  Proposed Tree
(Refer Plant Schedule & Detail)
 -  Grasses & Groundcovers
(Refer Plant Schedule & Detail)
 -  Planting Matrix 1
(Grasses and Groundcovers)
 -  Planting Matrix 2
(Screening Planting)
 -  Planting Matrix 3
(Cascading planting)



Existing Carpark

Dadi Drive

Honeycomb Drive Extension

For continuation refer 101

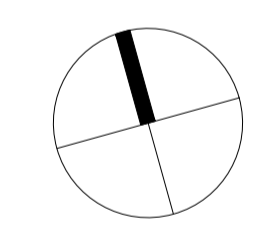

Client:
IRM Property Group (No2)

Project:
Bingo Recycling
Ecology Park
Eastern Creek

SITE IMAGE
Level 1, 3-5 Baptist Street
Redfern NSW 2016
Australia
Tel: (61 2) 8332 5600
Fax: (61 2) 9698 2877
www.siteimage.com.au
Site Image (NSW) Pty Ltd
ABN 44 801 262 380
Landscape Architects

SSD Application

Drawing Name:
Landscape Plan - 2

Scale: 1:200 @ A1
Job Number: SS20-4531
Drawing Number: 102
Issue: F

NOT FOR CONSTRUCTION

The contractor shall check and verify all work on site (including work by others) before commencing the landscape installation. Any discrepancies are to be reported to the Project Manager or Landscape Architect prior to commencing work. Do not scale this drawing. Any required dimensions not shown shall be referred to the Landscape Architect for confirmation.



Issue	Revision Description	Drawn	Check	Date
F	Response to Comments	VF	NM	13.06.2025
E	Response to Comments	LH	NM	29.08.2024
D	Civil Coordination	JD	NM	24.05.2023
C	Civil Coordination	SJ	NM	02.05.2023
B	Development Application	MW	NM	01.02.2022
A	Masterplan Thoughtput	JD	NM	17.07.2021

- LEGEND**
- Extent of Works
 - Proposed Tree
(Refer Plant Schedule & Detail)
 - Planting Matrix 1
(Grasses and Groundcovers)
 - Planting Matrix 2
(Screening Planting)
 - Planting Matrix 3
(Cascading planting)

Client:
IRM Property Group (No2)

Project:
Bingo Recycling Ecology Park Eastern Creek

SITE IMAGE
Level 1, 3-5 Baptist Street
Redfern NSW 2016
Australia
Tel: (61 2) 8332 5600
Fax: (61 2) 9698 2877
www.siteimage.com.au
Site Image (NSW) Pty Ltd
ABN 44 801 262 380

Landscape Architects

SSD Application
Drawing Name:
Landscape Plan - 3

Scale: 1:250 @ A1
Job Number: **SS20-4531**
Drawing Number: **103**
Issue: **F**

NOT FOR CONSTRUCTION

© 2021 Site Image (NSW) Pty Ltd ABN 44 801 262 380 as agent for Site Image NSW Partnership. All rights reserved. This drawing is copyright and shall not be reproduced or copied in any form or by any means (graphic, electronic or mechanical including photocopy) without the written permission of Site Image (NSW) Pty Ltd. Any license, expressed or implied, to use this document for any purpose what so ever is restricted to the terms of the written agreement between Site Image (NSW) Pty Ltd and the instructing party.

The contractor shall check and verify all work on site (including work by others) before commencing the landscape installation. Any discrepancies are to be reported to the Project Manager or Landscape Architect prior to commencing work. Do not scale this drawing. Any required dimensions not shown shall be referred to the Landscape Architect for confirmation.

Issue	Revision Description	Drawn	Check	Date
E	Response to Comments	VF	NM	13.08.2025
D	Civil Coordination	JD	NM	24.05.2023
C	Civil Coordination	SJ	NM	02.05.2023
B	Development Application	MW	NM	01.02.2022
A	Masterplan Thoughtput	JD	NM	17.07.2021

LEGEND

	Extent of Works
	Proposed Tree (Refer Plant Schedule & Detail)
	Planting Matrix 1 (Grasses and Groundcovers)
	Planting Matrix 2 (Screening Planting)
	Planting Matrix 3 (Cascading planting)

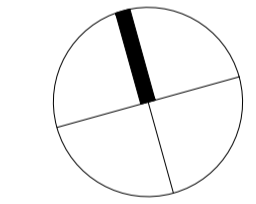

Client:
IRM Property Group (No2)

Project:
Bingo Recycling Ecology Park Eastern Creek

SITE IMAGE
Level 1, 3-5 Baptist Street
Redfern NSW 2016
Australia
Tel: (61 2) 8332 5600
Fax: (61 2) 9698 2877
www.siteimage.com.au
Site Image (NSW) Pty Ltd
ABN 44 801 262 380
Landscape Architects

SSD Application
Drawing Name:
Landscape Plan - 4

Scale: 1:250 @ A1
Job Number: **SS20-4531**
Drawing Number: **104**
Issue: **E**

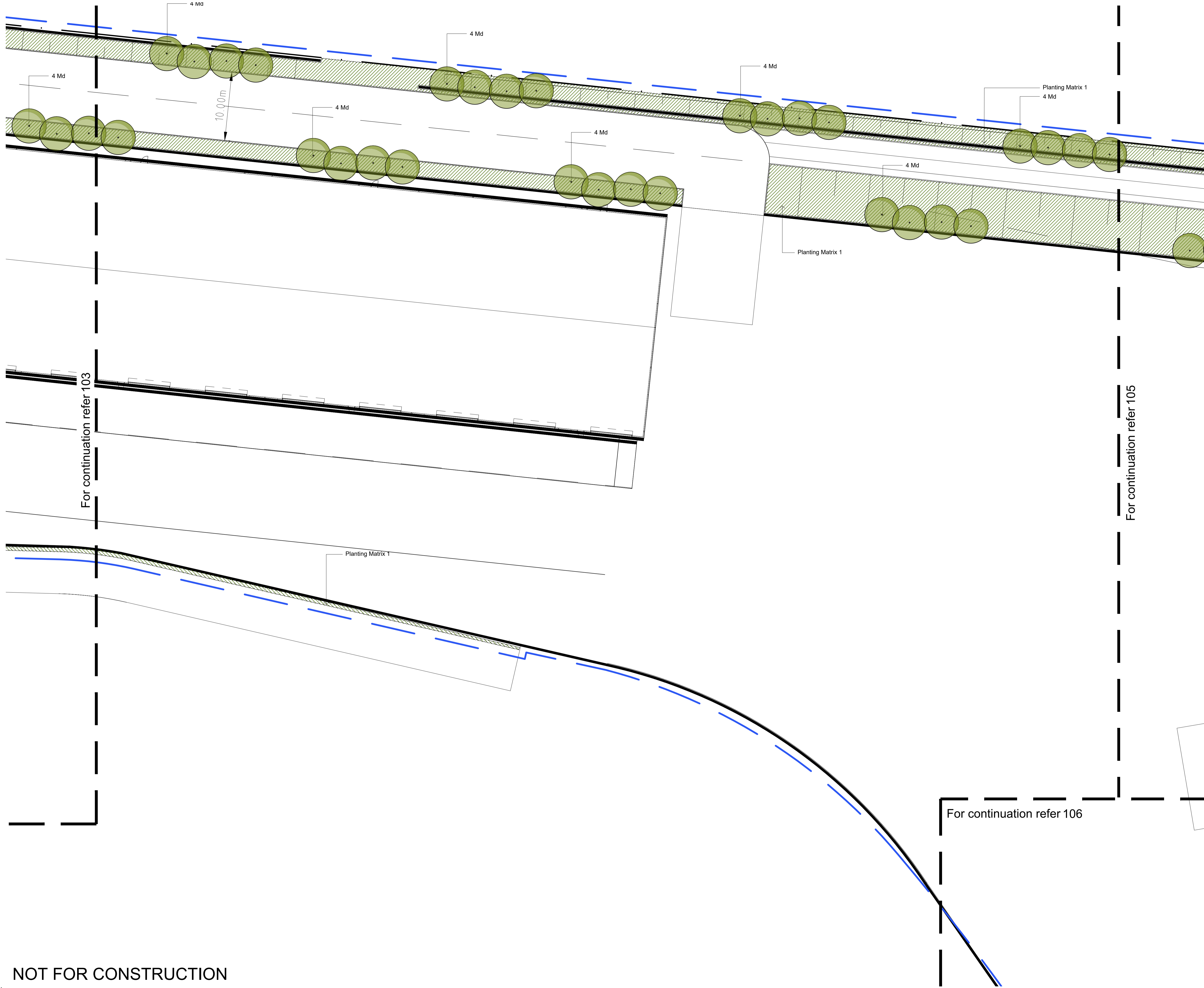

NOT FOR CONSTRUCTION

The contractor shall check and verify all work on site (including work by others) before commencing the landscape installation. Any discrepancies are to be reported to the Project Manager or Landscape Architect prior to commencing work. Do not scale this drawing. Any required dimensions not shown shall be referred to the Landscape Architect for confirmation.

F	Response to Comments	VF	NM	13.06.2025
E	Response to Comments	LH	NM	29.08.2024
D	Civil Coordination	JD	NM	24.05.2023
C	Civil Coordination	SJ	NM	02.05.2023
B	Development Application	MW	NM	01.02.2022
A	Masterplan Thoughtput	JD	NM	17.07.2021
Issue	Revision Description	Drawn	Check	Date

LEGEND

- Extent of Works
- Proposed Tree (Refer Plant Schedule & Detail)
- Planting Matrix 1 (Grasses and Groundcovers)
- Planting Matrix 2 (Screening Planting)
- Planting Matrix 3 (Cascading planting)

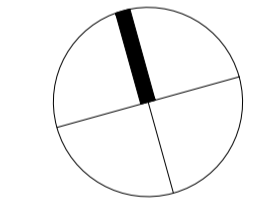

Client:
IRM Property Group (No2)

Project:
Bingo Recycling Ecology Park Eastern Creek

SITE IMAGE
Level 1, 3-5 Baptist Street
Redfern NSW 2016
Australia
Tel: (61 2) 8332 5600
Fax: (61 2) 9698 2877
www.siteimage.com.au
Site Image (NSW) Pty Ltd
ABN 44 801 262 380



SSD Application
Drawing Name:
Landscape Plan - 5

Scale: 1:250 @ A1
Job Number: SS20-4531
Drawing Number: 105
Issue: F

NOT FOR CONSTRUCTION

© 2021 Site Image (NSW) Pty Ltd ABN 44 801 262 380 as agent for Site Image NSW Partnership. All rights reserved. This drawing is copyright and shall not be reproduced or copied in any form or by any means (graphic, electronic or mechanical including photocopy) without the written permission of Site Image (NSW) Pty Ltd. Any license, expressed or implied, to use this document for any purpose what so ever is restricted to the terms of the written agreement between Site Image (NSW) Pty Ltd and the instructing party.

The contractor shall check and verify all work on site (including work by others) before commencing the landscape installation. Any discrepancies are to be reported to the Project Manager or Landscape Architect prior to commencing work. Do not scale this drawing. Any required dimensions not shown shall be referred to the Landscape Architect for confirmation.

F	Response to Comments	VF	NM	13.06.2025
E	Response to Comments	LH	NM	29.08.2024
D	Civil Coordination	JD	NM	24.05.2023
C	Civil Coordination	SJ	NM	02.05.2023
B	Development Application	MW	NM	01.02.2022
A	Masterplan Thoughtput	JD	NM	17.07.2021
Issue	Revision Description	Drawn	Check	Date

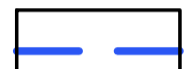
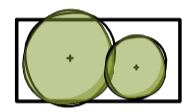
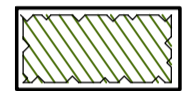
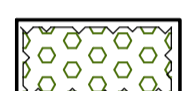
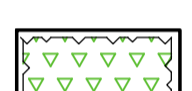
- LEGEND**
-  Extent of Works
 -  Proposed Tree
(Refer Plant Schedule & Detail)
 -  Planting Matrix 1
(Grasses and Groundcovers)
 -  Planting Matrix 2
(Screening Planting)
 -  Planting Matrix 3
(Cascading planting)

For continuation refer 105

For continuation refer 107

NOT FOR CONSTRUCTION

A1

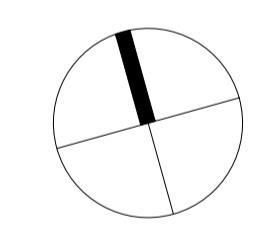
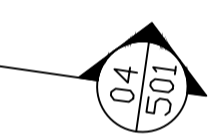
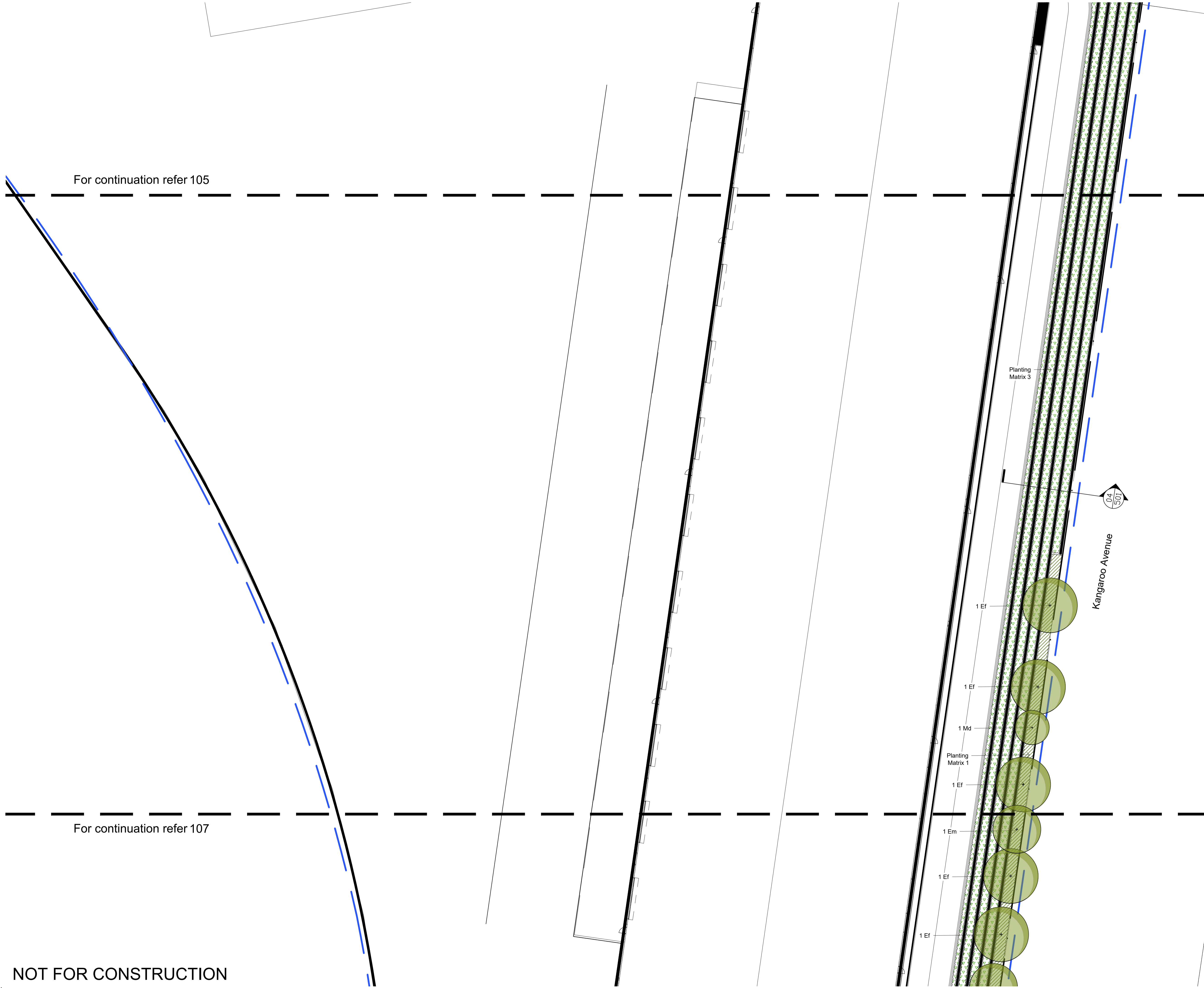

Client:
IRM Property Group (No2)

Project:
Bingo Recycling Ecology Park Eastern Creek

SITE IMAGE
Landscape Architects
Level 1, 3-5 Baptist Street
Redfern NSW 2016
Australia
Tel: (61 2) 8332 5600
Fax: (61 2) 9698 2877
www.siteimage.com.au
Site Image (NSW) Pty Ltd
ABN 44 801 262 380

SSD Application
Drawing Name:
Landscape Plan - 6

Scale: 1:250 @ A1
Job Number: **SS20-4531**
Drawing Number: **106**
Issue: **F**

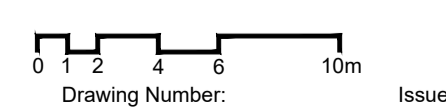

© 2021 Site Image (NSW) Pty Ltd ABN 44 801 262 380 as agent for Site Image NSW Partnership. All rights reserved. This drawing is copyright and shall not be reproduced or copied in any form or by any means (graphic, electronic or mechanical including photocopy) without the written permission of Site Image (NSW) Pty Ltd. Any license, expressed or implied, to use this document for any purpose whatsoever is restricted to the terms of the written agreement between Site Image (NSW) Pty Ltd and the instructing party.

The contractor shall check and verify all work on site (including work by others) before commencing the landscape installation. Any discrepancies are to be reported to the Project Manager or Landscape Architect prior to commencing work. Do not scale this drawing. Any required dimensions not shown shall be referred to the Landscape Architect for confirmation.

For continuation refer 106



Issue	Revision Description	Drawn	Check	Date
F	Response to Comments	VF	NM	13.06.2025
E	Response to Comments	LH	NM	29.08.2024
D	Civil Coordination	JD	NM	24.05.2023
C	Civil Coordination	SJ	NM	02.05.2023
B	Development Application	MW	NM	01.02.2022
A	Masterplan Thoughtput	JD	NM	17.07.2021

- LEGEND**
- Extent of Works
 - Proposed Tree (Refer Plant Schedule & Detail)
 - Planting Matrix 1 (Grasses and Groundcovers)
 - Planting Matrix 2 (Screening Planting)
 - Planting Matrix 3 (Cascading planting)

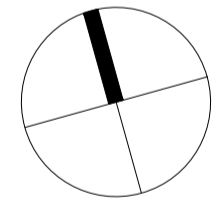

Client:
IRM Property Group (No2)

Project:
Bingo Recycling
Ecology Park
Eastern Creek

Level 1, 3-5 Baptist Street
Redfern NSW 2016
Australia
Tel: (61 2) 8332 5600
Fax: (61 2) 9698 2877
www.siteimage.com.au
Site Image (NSW) Pty Ltd
ABN 44 801 262 380



SSD Application

Drawing Name:
Landscape Plan - 7

Scale: 1:250 @ A1
Job Number:
SS20-4531

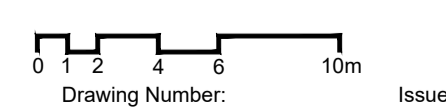

107 F



NOT FOR CONSTRUCTION

A1

The contractor shall check and verify all work on site (including work by others) before commencing the landscape installation. Any discrepancies are to be reported to the Project Manager or Landscape Architect prior to commencing work. Do not scale this drawing. Any required dimensions not shown shall be referred to the Landscape Architect for confirmation.

Issue	Revision Description	Drawn	Check	Date
A	Civil Coordination	JD	NM	24.05.2023

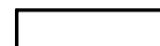
LEGEND

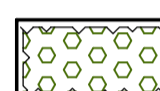
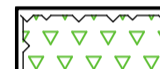
-  Extent of Works
-  Proposed Tree
(Refer Plant Schedule & Detail)
-  Planting Matrix 1
(Grasses and Groundcovers)
-  Planting Matrix 2
(Screening Planting)
-  Planting Matrix 3
(Cascading planting)

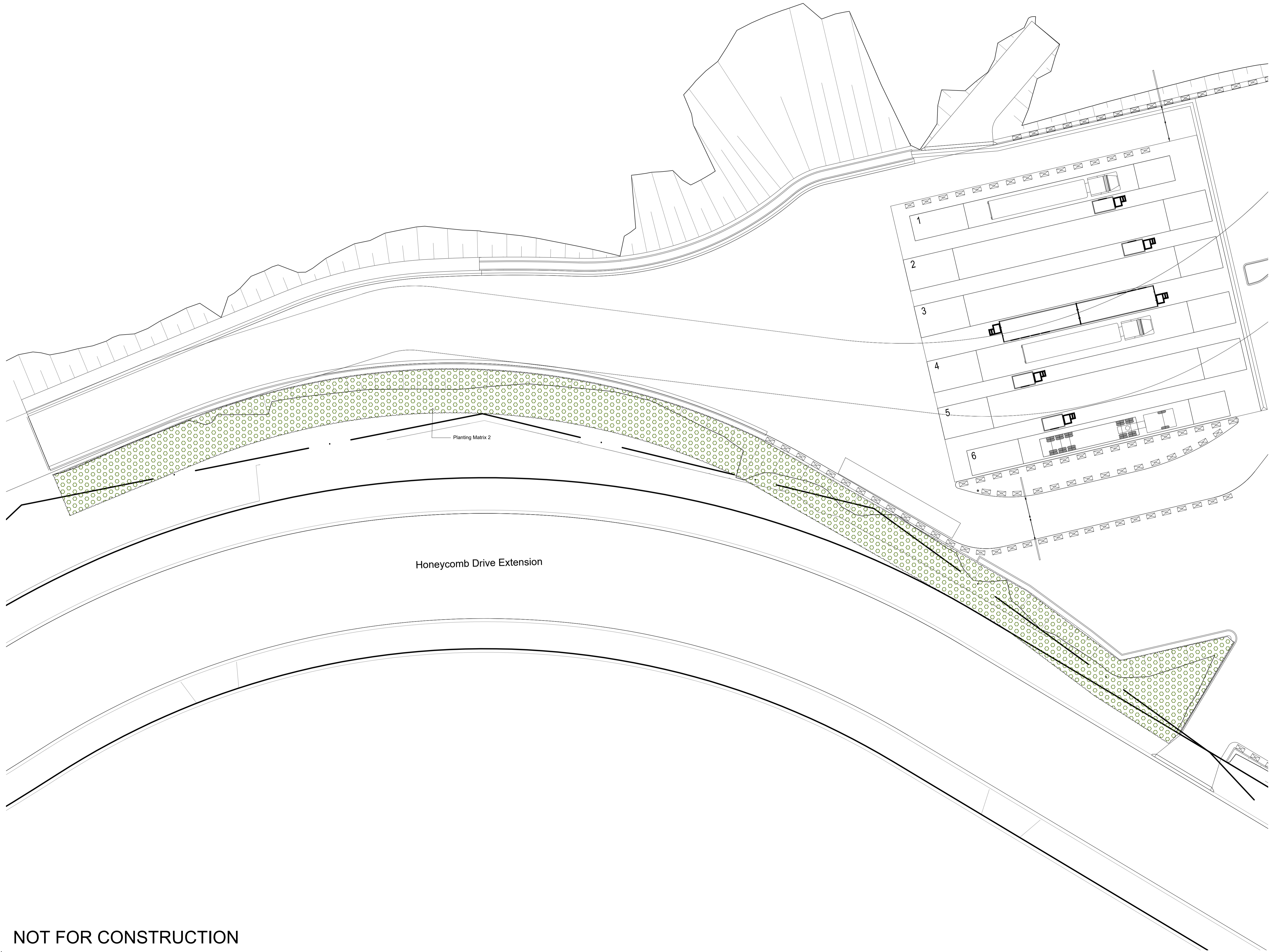

NOT FOR CONSTRUCTION

Client:
IRM Property Group (No2)

Project:
**Bingo Recycling
Ecology Park
Eastern Creek**

Level 1, 3-5 Baptist Street
Redfern NSW 2016
Australia
Tel: (61 2) 8332 5600
Fax: (61 2) 9698 2877
www.siteimage.com.au
Site Image (NSW) Pty Ltd
ABN 44 801 262 380



SSD Application
Drawing Name:
Landscape Plan - 8

Scale: 1:250 @ A1
Job Number: **SS20-4531**
Drawing Number: **108**
Issue: **A**

The contractor shall check and verify all work on site (including work by others) before commencing the landscape installation. Any discrepancies are to be reported to the Project Manager or Landscape Architect prior to commencing work. Do not scale this drawing. Any required dimensions not shown shall be referred to the Landscape Architect for confirmation.

C	Civil Coordination	SJ	NM	02.05.2023
B	Development Application	MW	NM	01.02.2022
A	Masterplan Thoughtput	JD	NM	17.07.2021
Issue	Revision Description	Drawn	Check	Date

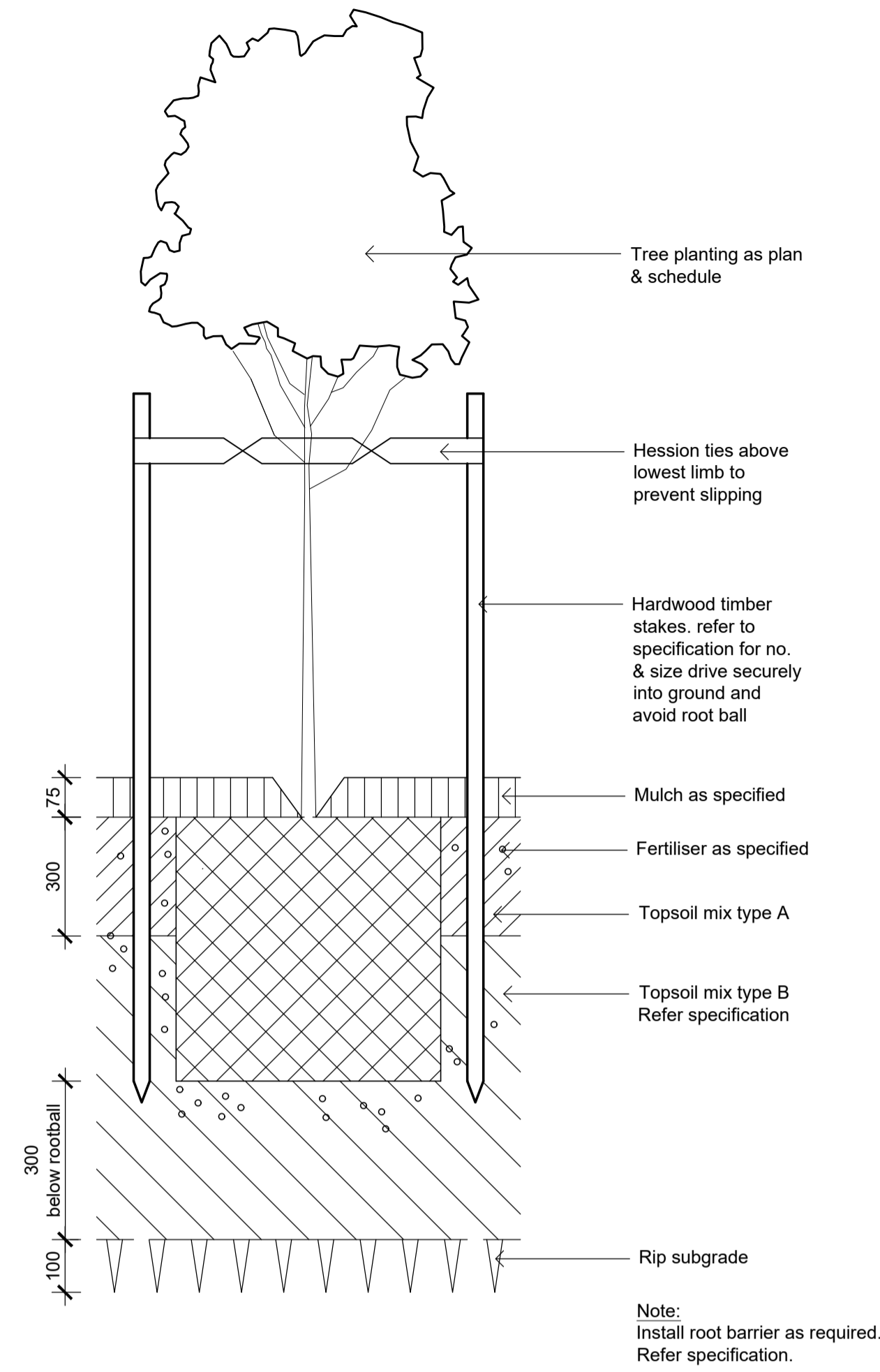

01 Detail 75-200L Tree Planting on Grade
501 1:10

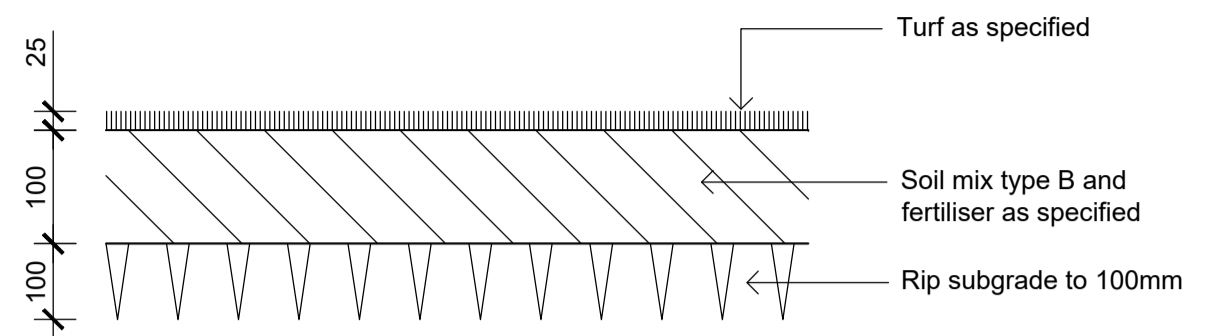

03 Detail Turf on Even Grade
501 1:10



04 Kangaroo Ave - Typical Retaining Wall Details
501 1:50

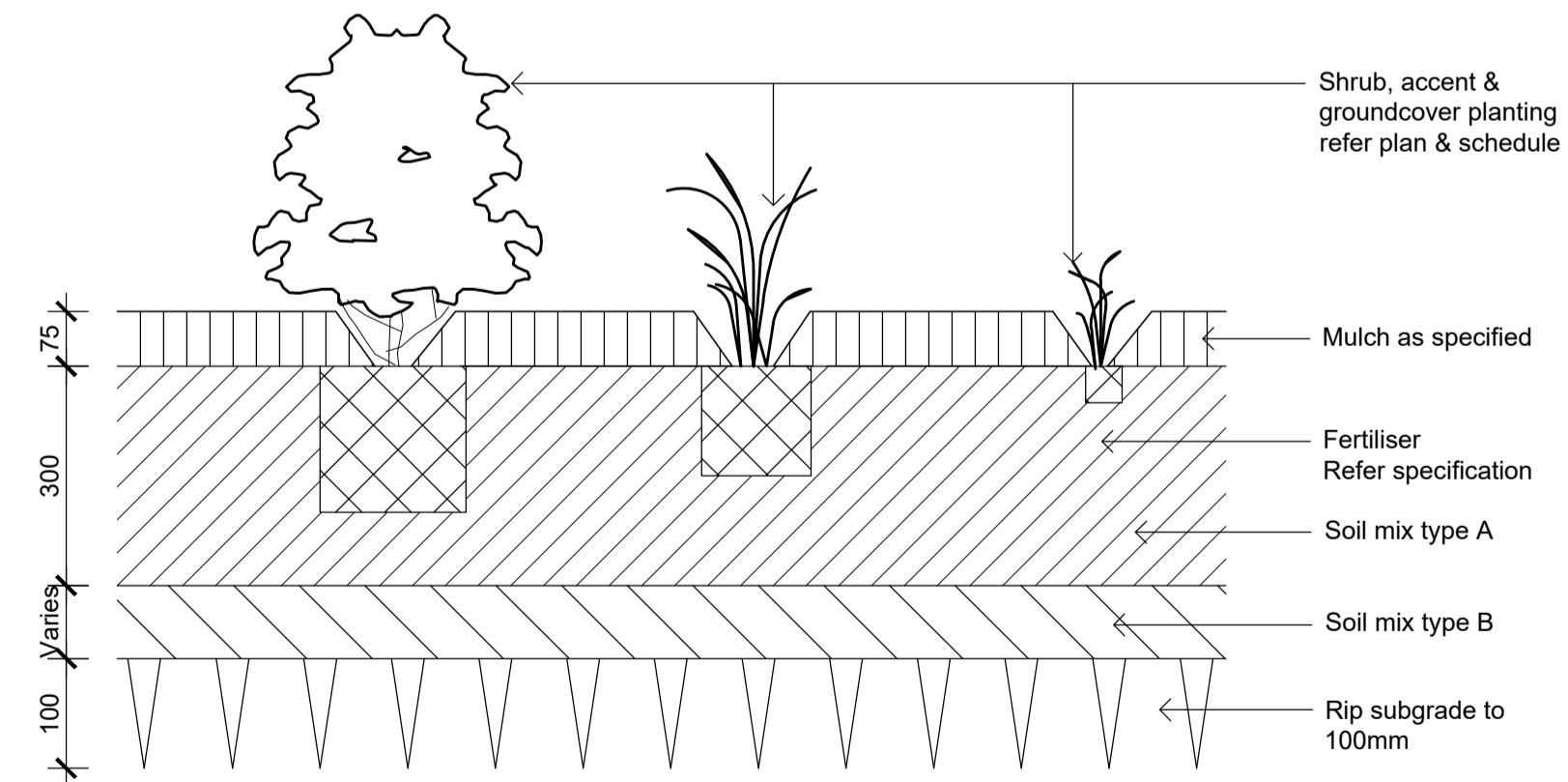

02 Detail Shrub Accent & Groundcover Planting on Grade
501 1:10

Client:
IRM Property Group (No2)

Project:
Bingo Recycling
Ecology Park
Eastern Creek

Level 1, 3-5 Baptist Street
Redfern NSW 2016
Australia
Tel: (61 2) 8332 5600
Fax: (61 2) 9698 2877
www.siteimage.com.au
Site Image (NSW) Pty Ltd
ABN 44 801 262 380



SSD Application

Drawing Name:
Landscape Details

Scale: AS SHOWN
Job Number: SS20-4531
Drawing Number: 501
Issue: C

NOT FOR CONSTRUCTION