

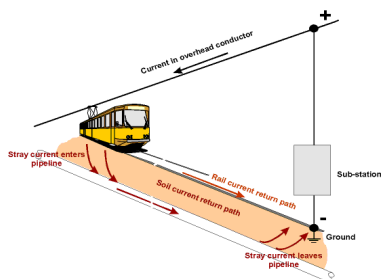

## REPORT TO AUSTRALAND

# DISCOVERY POINT DEVELOPMENT STAGE 1 ANALYSIS OF STRAY TRACTION CURRENT



***Cathodic Protection Services***

*P O Box 118*

*CONCORD NSW 2137*

*Phone: 02-97452785*

*Fax: 02-97448542*

*Email: [cathodic@pnc.com.au](mailto:cathodic@pnc.com.au)*

*Report A715 Stage 1,*

*January 11, 2011*

**\*\* TABLE OF CONTENTS \*\***

<b>1.</b>	<b>INTRODUCTION</b>	<b>3</b>
<b>2.</b>	<b>SUMMARY</b>	<b>4</b>
<b>3.</b>	<b>DIAPHRAGM WALL</b>	<b>4</b>
<b>4.</b>	<b>GENERAL CONSTRUCTION</b>	<b>5</b>
4.1	FLOOR OR BASEMENT SLABS	5
4.2	UNDERGROUND WALLS	5
4.3	REINFORCED CONCRETE STRIP FOOTINGS	5
4.4	CONCRETE REINFORCED PIERS	6
4.5	WATER AND GAS SERVICES	6
4.6	METALLIC FENCES	7
<b>5.</b>	<b>CONCLUSION</b>	<b>8</b>

**APPENDICES**

- A. CORROSION BY STRAY TRACTION CURRENT**
- B. DIAGRAM, STRAY TRACTION CURRENT**
- C. INSULATING FLANGE KITS**

## 1. INTRODUCTION

Cathodic Protection Services were requested to provide advice on hazards from stray traction current to the Discovery Point Project Application, Stage 1

The NSW Department of Planning requires Director General's Requirement [DGR] be satisfied:

*The EA shall provide a report by an electrolysis expert on the Electrolysis Risk to the Development from stray traction current."*

The Discovery Point Concept Plan Site at Wollie Creek is located between two electrified rail lines, and is adjacent to the SRA Wollie Creek substation. As a consequence the Stage 1 Project Application site is in an area where stray traction current can be expected to be returning to the substation.

The aspects of the Stage 1 Project Application which were requested to be addressed are;

- The diaphragm wall
- General comments applicable to the high rise Dwellings
- The bridge structure over the Airport line

An initial inspection was made of Discovery Point on March 10, 2006 with former Australand, Project manager, Mr Eugene White.

Further discussion on the overall Concept Plan was held with Australand's Mr Chris Pope and members of the Consultant Team for the Part 3A Concept Plan application at Bates Smart Offices on April 16, 2010

Comments made in this report are in accordance with Rail Infrastructure Electrical Engineering Standard EP 12 30 00 01 SP, "ELECTROLYSIS FROM STRAY DC CURRENT".

This Report updates the interim report prepared for the Concept Plan Application.

An outline of the corrosion hazards from stray traction current is provided in Appendix A.

## **2. SUMMARY**

Stray traction current can cause serious corrosion to underground metallic structures and services. Stray traction current is low voltage and is not considered a hazard to human life.

Cathodic Protection Services have reviewed the underground structures associated with the Stage 1 development and the potential hazards from stray traction current. Whilst some corrosion hazards were identified, these can generally be eliminated by simple and inexpensive means as detailed below.

## **3. DIAPHRAGM WALL**

The Bates Smart Project Application Plan show that the existing diaphragm wall beneath proposed Building 1C and 2 is to be retained.

The diaphragm wall is constructed in discrete reinforced concrete panels six [6] m in length. No electrical interconnection exists between the individual panels of the wall.

Because of their short length, the panels of the diaphragm wall do not present an “attractive” conductive path for the conduction of stray traction current.

## **4. GENERAL CONSTRUCTION**

There are a number of recommendations relating to stray traction current corrosion hazards which should be integrated into the construction of the proposed buildings of The Stage 1 Project Application.

### ***4.1 FLOOR OR BASEMENT SLABS***

Floor or basement reinforced concrete slabs are universally laid on a moisture barrier. The moisture barrier acts as an electrical insulator which prevents the entry of stray traction current.

### ***4.2 UNDERGROUND WALLS***

Generally reinforced concrete walls are also provided with moisture barriers or air gaps. These act to prevent the entry of stray traction current.

### ***4.3 REINFORCED CONCRETE STRIP FOOTINGS***

Reinforced concrete footings are commonly poured directly into the excavation. Whilst an individual footing is too small to provide an alternate path to the earth for stray traction current, because the footings are interconnected by the reinforcement of the floor slab, stray traction current can be picked up at one side of the building and flow via the floor slab reinforcement to a footing at the opposite side of the building. At the point where the current discharges back to earth, corrosion of the reinforcement will occur.

Solutions available to avoid the corrosion hazard on footing reinforcement are;

- a. The excavation can be provided with a moisture barrier,
- or,

- b. The starter bars of the footing can be electrically insulated from the slab reinforcement by applying insulating sleeving to the connection points between the footing starter bars to the slab reinforcement.

or

- c. If the footings are constructed from high strength concrete, minimum 32 mpa, and provided with adequate cover, 50mm, this strength and cover are considered to provide sufficient protection to the steel reinforcing protect it from stray traction current.

#### ***4.4 CONCRETE REINFORCED PIERS***

Steel reinforced concrete piers, for structural reasons are commonly constructed from 40 mpa concrete and provided with 70 mm of concrete cover. Concrete of this strength and cover is considered to provide adequate protection to the reinforcing to eliminate corrosion hazards from stray traction current.

#### ***4.5 WATER AND GAS SERVICES***

Stray traction current can affect metallic water, fire and gas services. Sewer lines are generally constructed from non metallic materials and are not subject to corrosion hazards from stray traction current. [full stop added] Should stray traction current be picked up by the services, this can result in a corrosion problem on;

- a. The services
- b. The Development's electrical earth system. This is because the earth and the water service have a direct connection via the MEN system. Current picked up by the water and/or fire services can discharge back to the earth via the earth resulting in corrosion of the earth grid.

This problem can be eliminated by installation of an insulating fitting, or non-metallic sections in the services at or close to the boundary of the property.

Further comments are;

- a. If the water meter is of non-metallic construction this will provide the insulation required.
- b. The fire service will require installation of an insulation flange kit in the line.
- c. The gas service can be expected to incorporate an insulating fitting at the meter. The Gas Providers apply cathodic protection to their metallic supply lines and these require an insulating fitting at the property boundary to maintain their cathodic protection systems. Alternately if the service is non-metallic, this provides the necessary insulating properties

Insulation flange kits consist of;

- a. A set of insulating sleeves and washers which fit on the bolts and electrically isolate the bolts from the flange. The bolt sleeves are designed to fit within the flange bolt holes. [Note: except for Table D flanges]
- b. A heavy non water adsorbent gasket.

#### **4.6 METALLIC FENCES**

Metallic fences can act as conductors of stray traction current. Standard EP 12 30 00 01 SP nominates;

“Metallic line side fencing shall have insulating panels installed every 500m.”

A review of the metallic fences associated will need to be made at CC Stage to determine whether any fences are subject to a corrosion hazard from stray traction current.

## **5. CONCLUSION**

The recommendations of this report will ensure the proposed structure will be protected from corrosion hazards from stray traction currents.

*Cathodic Protection Services*

*January 11, 2011*

## **APPENDIX A CORROSION BY STRAY TRACTION CURRENT**

### **A1. THE PROBLEM.**

The SRA use 1500 volt direct current to operate the traction system. The current is delivered by the overhead catenary cables and the return path to the sub station is via the track. The track is not insulated from earth, principally because of the difficulty of achieving insulation and secondly, for safety reasons. Whilst the steel track is large in cross section, some of the current leaks from the tracks and finds alternate paths back to the sub station. Considerable current can be involved, for instance, a Tangara train requires about 4000 amps to start from rest.

All current obeys Ohms Law and if a low resistance metallic structure exists in the path of the “stray” current this can pick up the stray current which then flows along the structure to a point close to the sub station, where it discharges back to earth, and ultimately returns to the sub station.

Where the “foreign” structure picks up the stray current a small measure of corrosion control or “cathodic protection” is achieved. However, where the current discharges from the foreign structure back to the soil, corrosion of the foreign structure occurs as shown on Sketch CP34.

The problem of stray current corrosion was first identified in the 1930's. For stray current to be a serious problem the foreign structure has to be electrically continuous.

At that time the only organisation which had electrically continuous structures were the PMG with their lead sheathed cables. They suffered corrosion failures and for many years considered this to be a necessary evil. However an enterprising Engineer decided to plot failures on a map and found they were predominantly grouped around rail lines or tram lines.

Further investigation showed that they were also grouped around the sub stations associated with the tracks. He eventually identified the corrosion problem as being caused by stray current. The PMG approached the Railways for compensation and it did appear that the Federal Government would be suing the State Government.

Whilst this was occurring the Engineering staff developed a solution to the problem. This was to connect the foreign structure to the tracks via a simple control system.

This provided a low resistance path for the stray current to return to the tracks thus eliminating the corrosion problem. The control bond could be engineered such that a degree of additional corrosion protection could be provided to the foreign structure.

The above led to the formation of the Electrolysis Committee which has representatives of the owners of all underground services and the SRA. Cathodic Protection Services represents the interests of the Oil and Chemical Industries. Apart from the War Years the committee has met at 4 week intervals since the 1930's to discuss stray current problems and its mitigation with the Railways.

## **A2. MITIGATION OF STRAY CURRENT**

There are a number of options to deal with the potential corrosion problems which can result from stray traction current. These include,

- a. Prevent or reduce exposure of the structure to stray traction current.
- b. Install a mitigation system to offset the problem.

In the case of the latter this is an expensive approach as it requires the establishment of infrastructure necessary for the mitigation of the problem.

## **A3. ELIMINATE OR REDUCE EXPOSURE TO STRAY TRACTION CURRENT**

The soundest approach is to avoid exposure of the structure to stray traction current. Two approaches, which can be adopted, are;

***A3.1. Reduce Length of Structure in Alignment with Traction Current Path.***

As noted in Section 5, the hazard from stray traction current is due to the current flowing onto and then off the metallic structure. Corrosion occurs at the point of discharge of the current back to the soil.

The hazard from the stray traction current increases as the length of the conducting service increases. Stray traction corrosion is a problem because the metallic service presents a lower electrical resistance path to current flow than the alternative path through the earth.

For current to flow onto and discharge from an underground structure, electrochemical reactions need to occur to generate or absorb electrons. Both these reactions require energy, which results in a resistance existing between the structure and the earth. If the structure is short in length, the combined resistance of the pick up and discharge reactions is sufficient to prevent the traction current flowing onto the structure.

Additional to the above, the passage of the stray traction current causes development of potential gradient in the earth. For a short metallic conductor, the potential gradient to which it is exposed to too small to allow the pick up of the current.

Accordingly the shorter the length of the metallic structure the less likely it is to be affected by stray traction current.

***A3.2. Isolate the Structure from Stray Traction Current.***

The effects of stray traction current can be avoided by increasing the resistance of the structure to the soils in which stray traction current is flowing. This can be achieved by use of moisture barriers such as FORTICON which provides an electrically insulating membrane which prevents entry of stray traction current.

Even if the membrane is damaged, it will still provide sufficient resistance to prevent entry of stray traction current

#### **A4 STRAY TRACTION CURRENT MITIGATION**

Stray traction current mitigation is achieved by providing a low resistance path from the structure to allow discharge of any stray traction current directly back to the rail.

Provision of a mitigation system involves the following;

- a. The reinforcement of the concrete has to be made electrically continuous. This involves tack welding all members of the reinforcement cages.
- b. Testing has to be undertaken to provide evidence to the Railways that a stray traction current corrosion hazard exists.
- c. If the testing identifies a corrosion hazard to the steel reinforcement does exist, installation of a “railway drainage bond” can proceed.

It will be appreciated that installation of a mitigation system is a particularly expensive option. The only building projects on which Cathodic Protection Services have recommended a stray traction mitigation system are;

The Sydney Harbour Tunnel. This structure is 3200m in length and testing indicated the existence of a stray traction current hazard.

Chatswood Connection Project. This development by Girvan was over one km in length and provision for a stray traction current mitigation system was being designed into the proposed project.

**APPENDIX B**

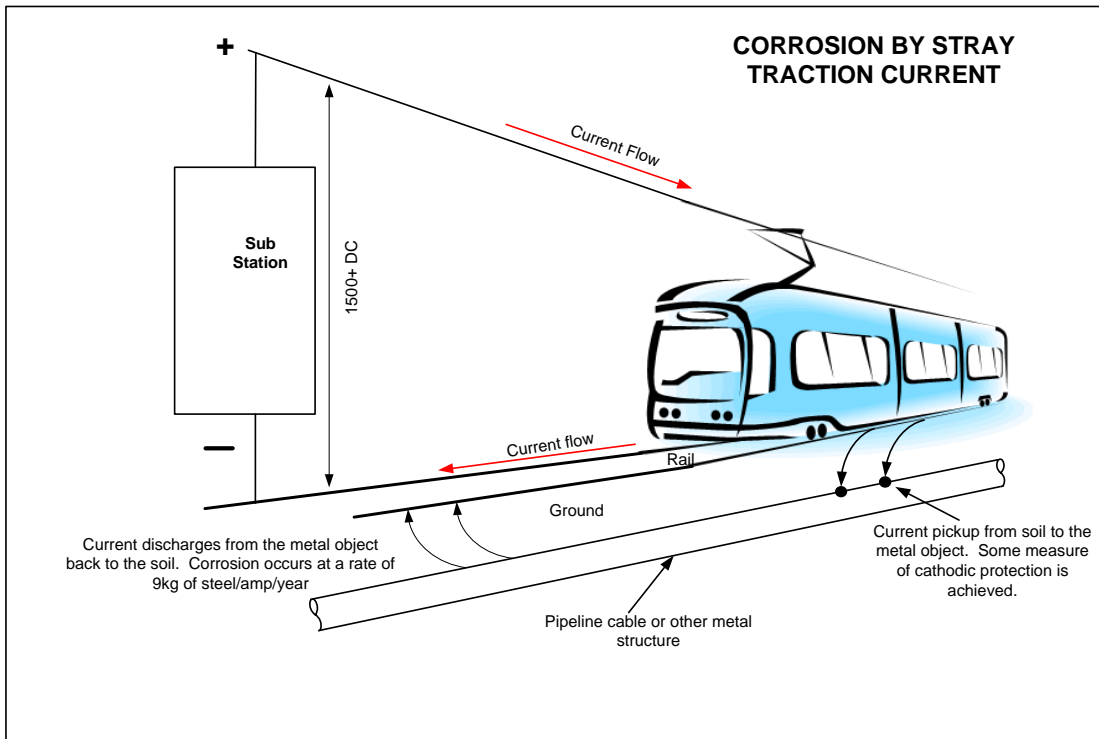

APPENDIX C

**flange**



**insulation**

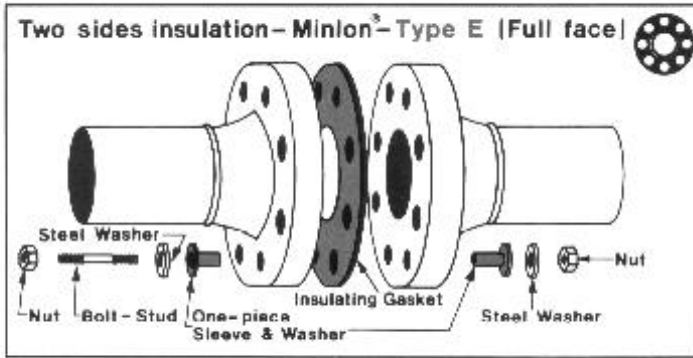

Type "E" gaskets perfectly center on precisely located bolt holes. Since their outside diameters are the same, foreign material is prevented from "shorting" the flange insulation.

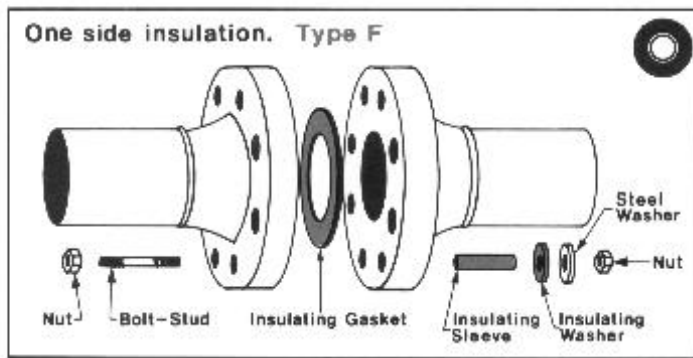

Type "F" gaskets are made without bolt holes, to fit tightly inside the overall bolt hole circle of the flange faces. The outside diameter of the gasket fits tightly in place assuring a well centered position.

**CENTRAL FLANGE INSULATION KIT**

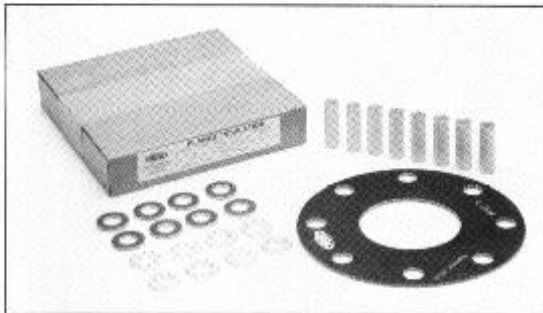

**INSULATING SLEEVES**  
 • POLYETHYLENE  
 • MYLAR<sup>1</sup>  
 • PHENOLIC  
 • EPOXY GLASS  
 • OTHERS



**INSULATING WASHERS**  
 • PHENOLIC  
 • EPOXY GLASS  
 • OTHERS

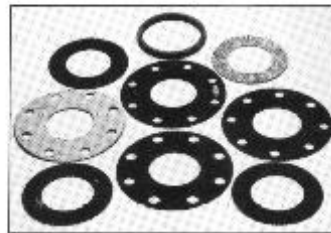

**INSULATING GASKETS**  
 • TYPE E - FULL FACE  
 • TYPE F - RING  
 • TYPE D - RTJ, BX  
 • Jask-O - RING  
 NEOPRENE FACED PHENOLIC  
 PHENOLIC  
 J.M. 71<sup>2</sup> ASBESTOS  
 EPOXY GLASS  
 OTHERS

**SEAL RING**  
 • NITRILE, BUNA-N  
 • VITON  
 • OTHERS

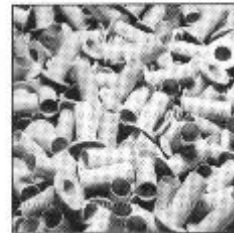

**MOLDED ONE-PIECE SLEEVE & WASHER**  
 • MINLON<sup>2</sup>

(Standard Gasket Width-1/8")

FOR BEST RESULTS  
**CENTRAL** RECOMMENDS

# Jock™ O-RING GASKETS

**BEFORE:** The flange face contacts the crown of the elastomer seal ring. As the bolts are tightened the flange face deforms the seal crown into the molded voids.

**AFTER:** The flange faces are in complete contact with the seal retainer, thus encapsulating the seal elements in conjunction with the retainer grooves. The elastomer, because of its resiliency and pressure from the line fluid, attempts to return to its original shape and effects a positive o-ring type seal.

**PROBLEMS SOLVED** .....

- Fewer Service Calls due to leaking and "shorting" flanges.
- Positive Sealing through a wide range of fluctuating temperatures.
- Maintenance Versatility and Positive Sealing in difficult situations. [see examples]
- Longest Fire Life of any insulating gasket.
- Positive Seals and Zero Environmental Leakage.

## HOW?

TO ORDER FLANGE INSULATION KIT PLEASE INDICATE THE FOLLOWING:

1. Quantity
2. Pipe Size (Nominal)
3. Pressure Rating (ANSI, DIN, API)
4. Gasket Type
5. Retainer Material
6. Sealing Element
7. Single or Double Washer Sets (SW or DW)
8. Sleeve Material



Distributed by

**SAVCOR ART Pty Ltd**

Lvl 13/132 Arthur St, Nth Sydney NSW 2060  
 Phone 02 9025 2000

