

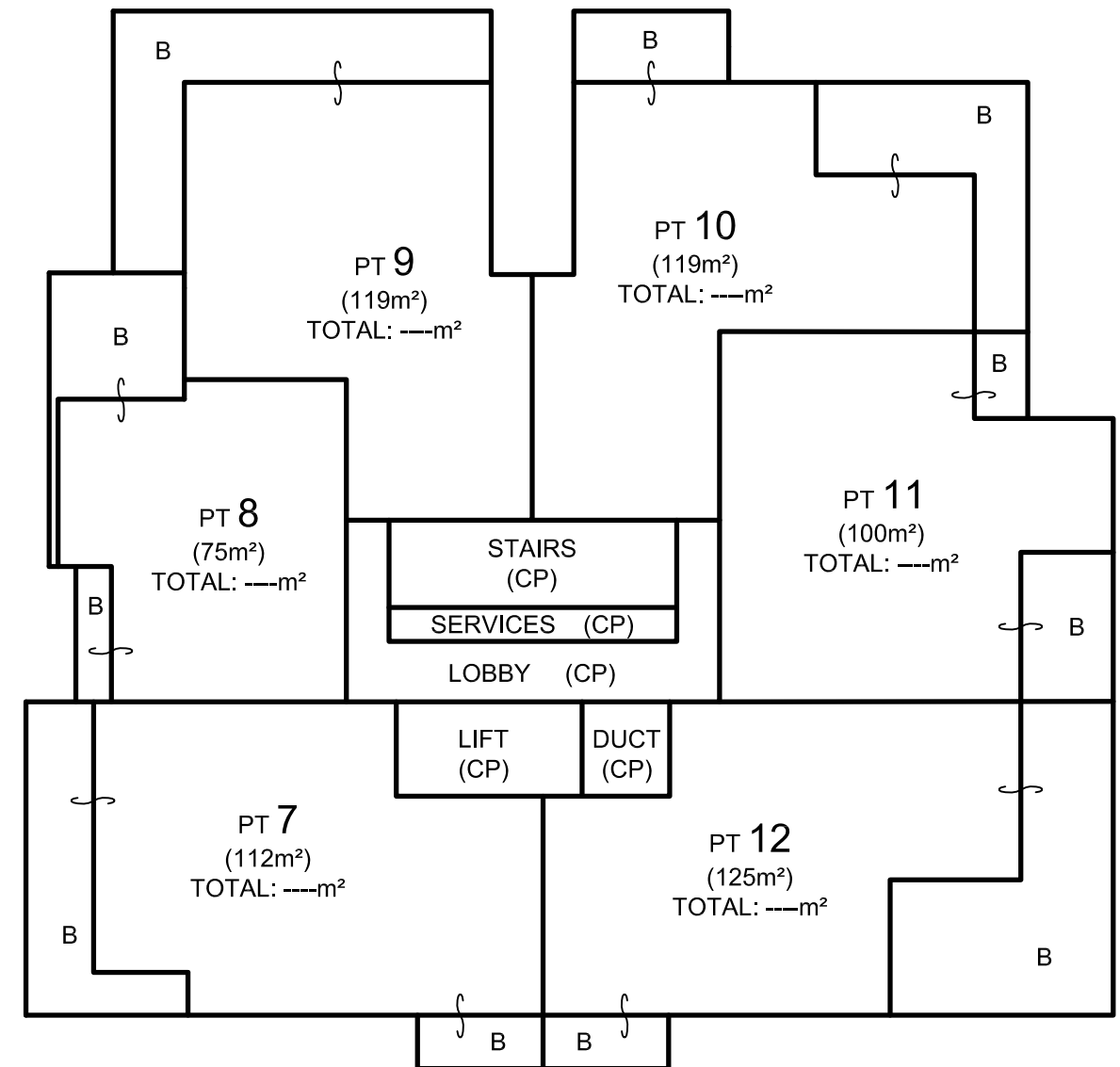

LEVEL 5

LEVEL 6

PRELIMINARY PLAN ONLY, SCALED FROM ARCHITECTS PLANS & SUBJECT TO ADDITIONS & ALTERATIONS UPON FINAL SURVEY.

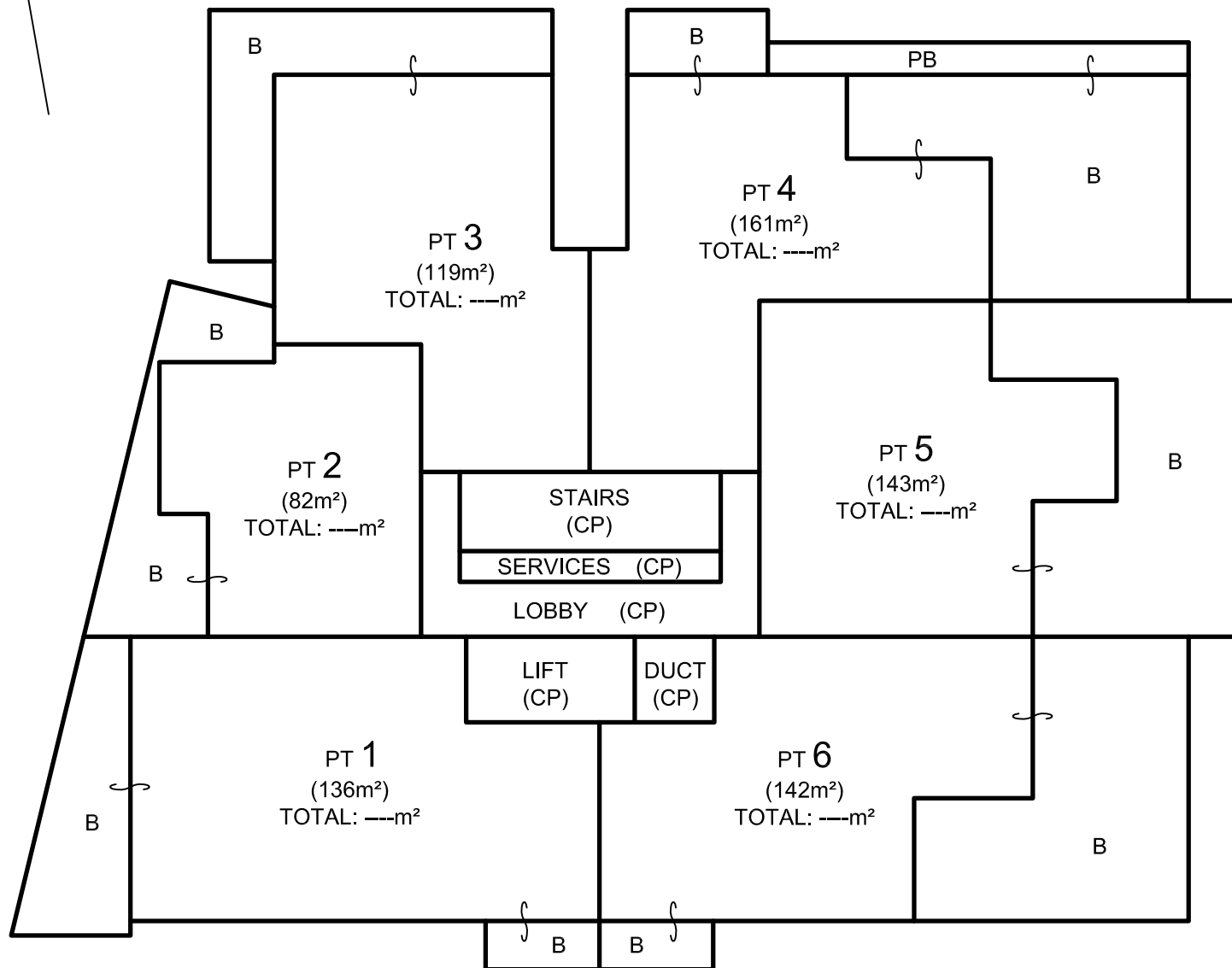

B DENOTES BALCONY HAVING A CONCRETE SURFACE AND LIMITED IN HEIGHT TO 3m ABOVE CONCRETE SURFACE, EXCEPT WHERE COVERED

CP DENOTES COMMON PROPERTY

PB DENOTES PLANTER BOX HAVING A CONCRETE SURFACE AND LIMITED IN HEIGHT TO 3m

ALL WATER PROOFING FORMS PART OF THE COMMON PROPERTY

ALL BALCONY FLOOR COVERINGS FORM PART OF THEIR RESPECTIVE LOT

ALL SERVICE DUCTS, CABLES, PIPES & CONDUITS FORM PART OF THE COMMON PROPERTY

AREAS ARE APPROXIMATE ONLY SHOWN FOR THE PURPOSES OF THE STRATA SCHEMES (FREEHOLD DEVELOPMENT) ACT 1973

Surveyor: JOHN WALTON
 Surveyor's Ref: 750-09 (RES)
 Subdivision No:

Lengths are in metres Reduction Ratio 1 : 200

Registered

**DRAFT
 AUG-2011**

SP



LEVEL 7

LEVEL 8

PRELIMINARY PLAN ONLY, SCALED FROM ARCHITECTS PLANS & SUBJECT TO ADDITIONS & ALTERATIONS UPON FINAL SURVEY.

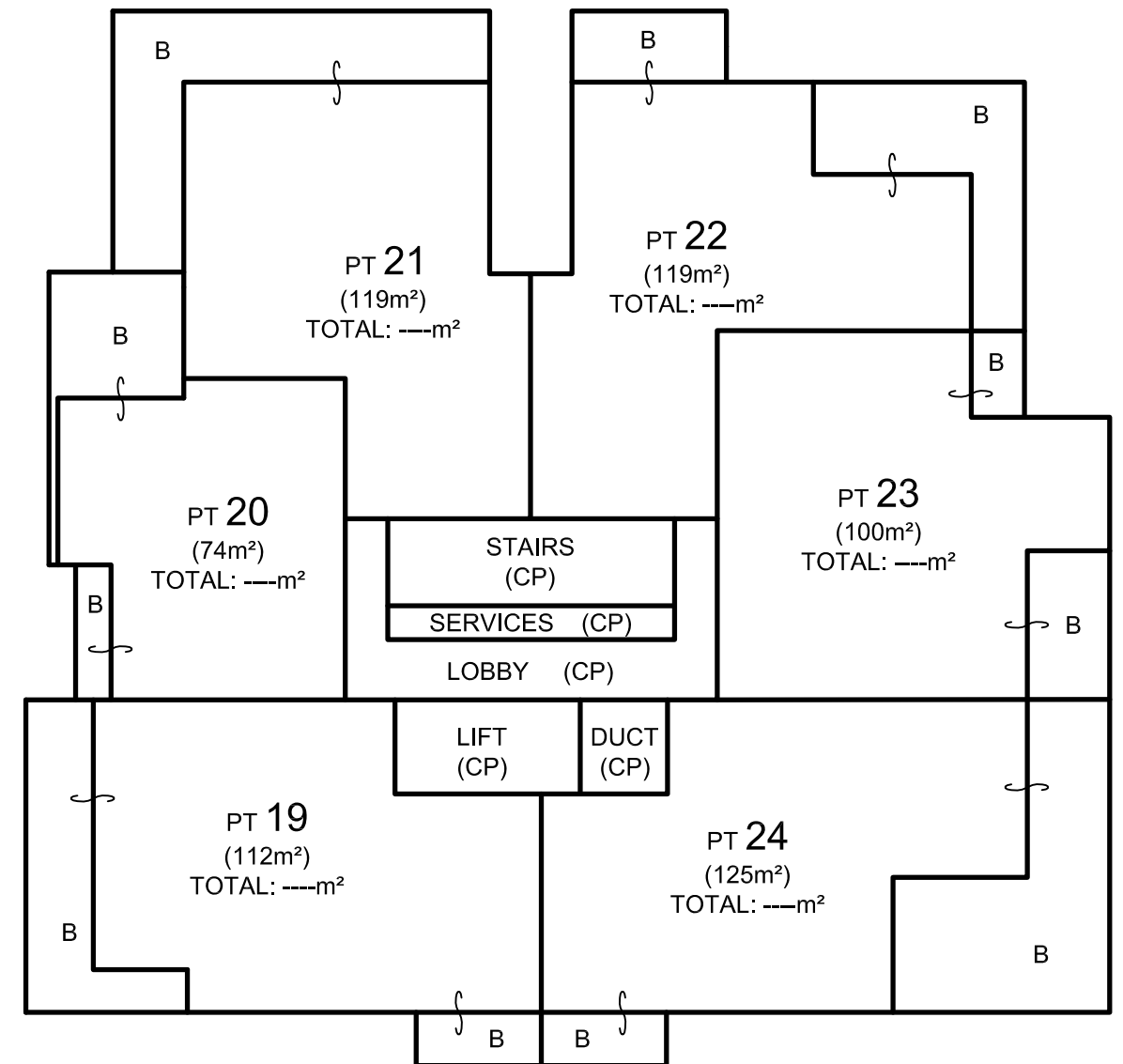
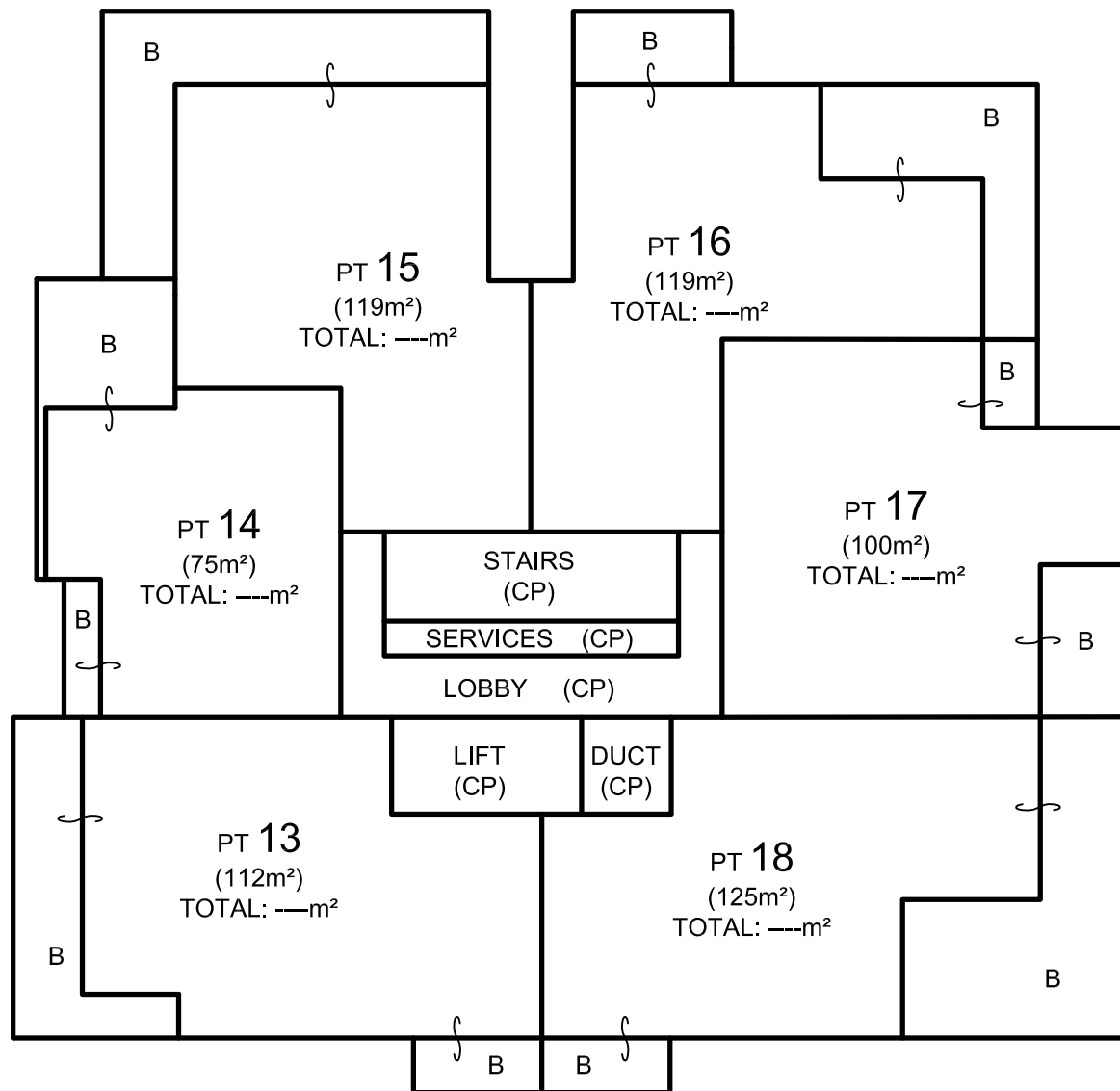

B DENOTES BALCONY HAVING A CONCRETE SURFACE AND IS COVERED

CP DENOTES COMMON PROPERTY

ALL WATER PROOFING FORMS PART OF THE COMMON PROPERTY

ALL BALCONY FLOOR COVERINGS FORM PART OF THEIR RESPECTIVE LOT

ALL SERVICE DUCTS, CABLES, PIPES & CONDUITS FORM PART OF THE COMMON PROPERTY

AREAS ARE APPROXIMATE ONLY SHOWN FOR THE PURPOSES OF THE STRATA SCHEMES (FREEHOLD DEVELOPMENT) ACT 1973

Surveyor: JOHN WALTON
 Surveyor's Ref: 750-09 (RES)
 Subdivision No:

Registered

DRAFT
AUG-2011

SP

Lengths are in metres Reduction Ratio 1 : 200



LEVEL 9

LEVEL 10

PRELIMINARY PLAN ONLY, SCALED FROM ARCHITECTS PLANS & SUBJECT TO ADDITIONS & ALTERATIONS UPON FINAL SURVEY.

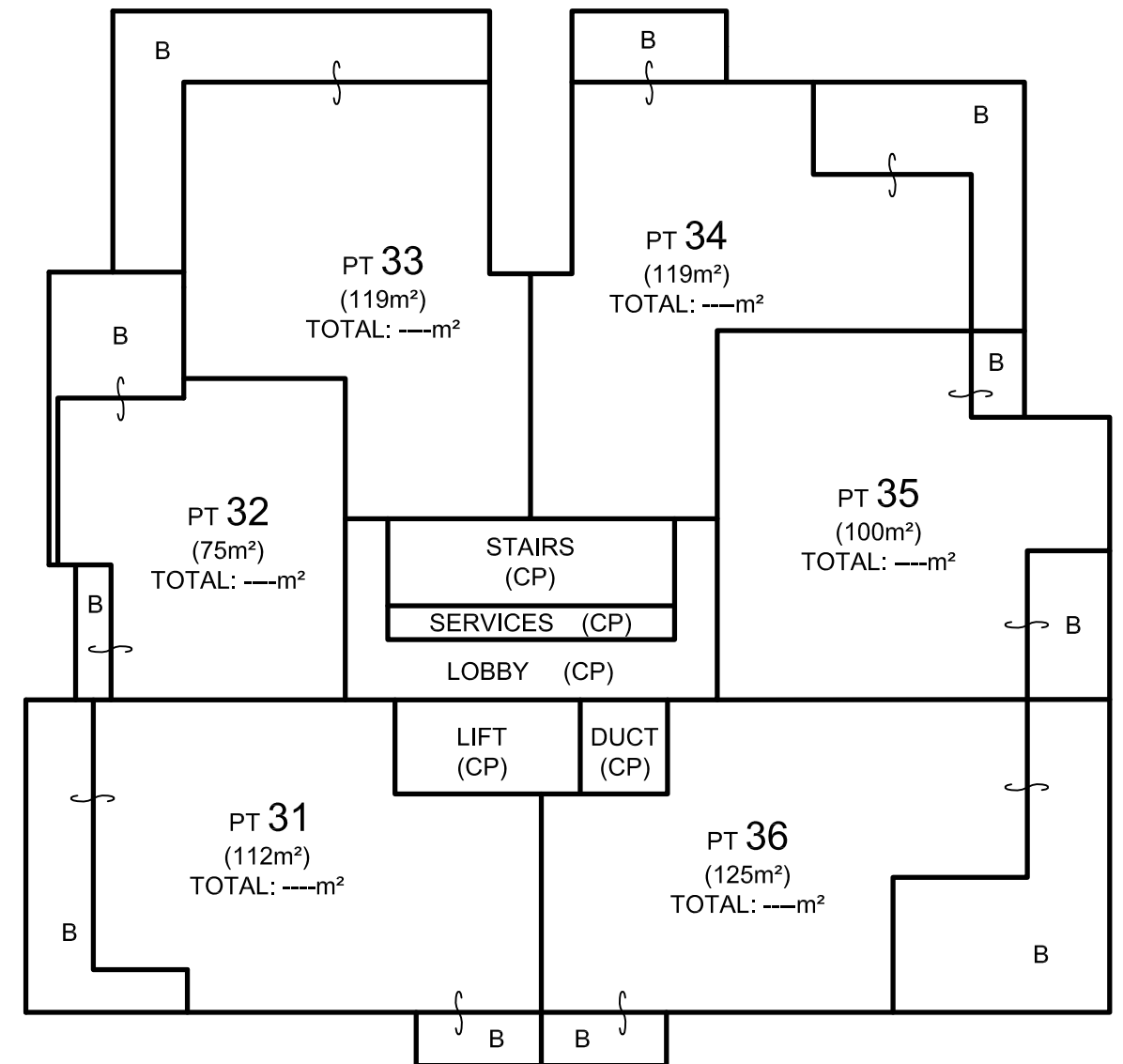
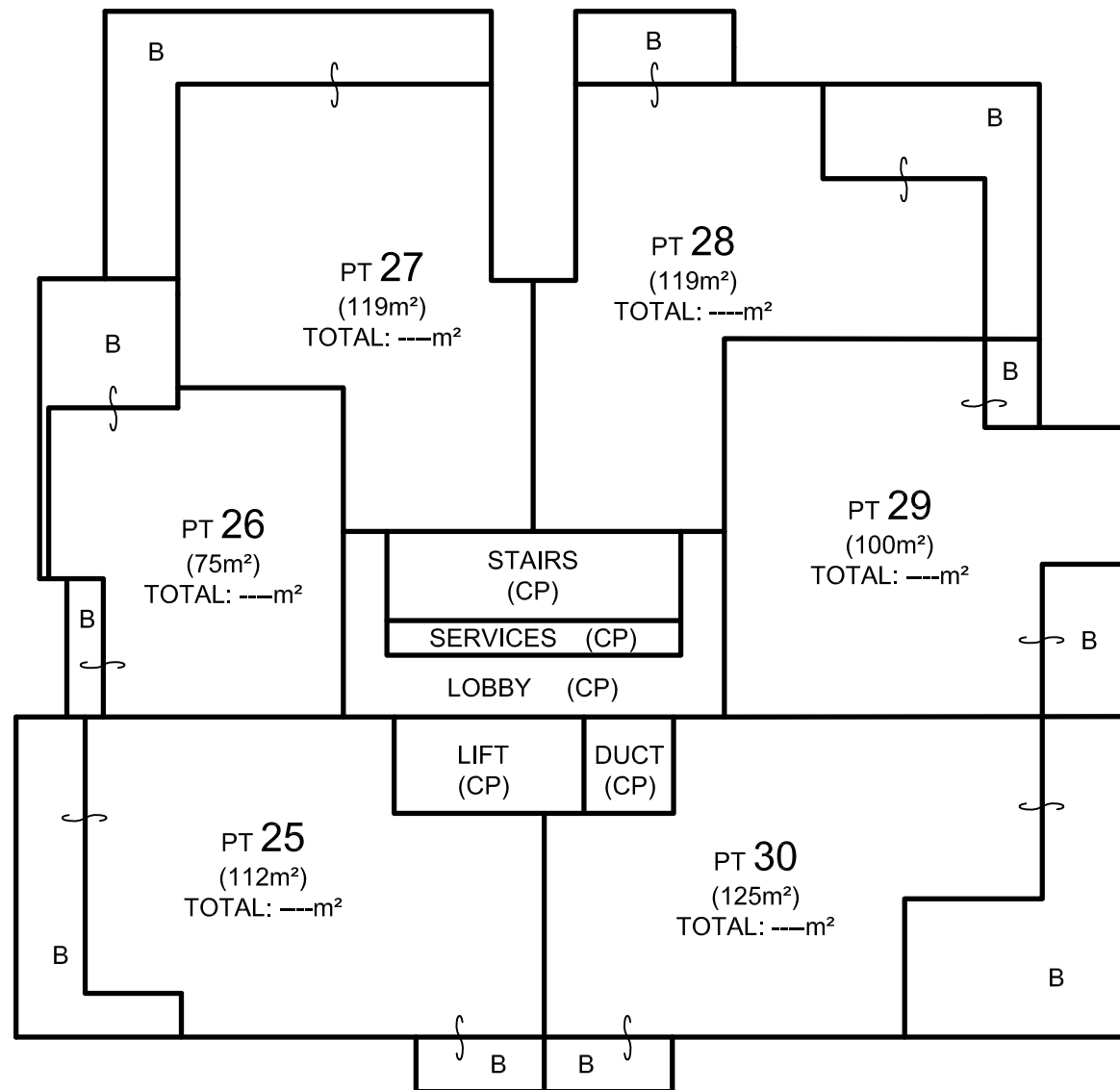

B DENOTES BALCONY HAVING A CONCRETE SURFACE AND IS COVERED

CP DENOTES COMMON PROPERTY

ALL WATER PROOFING FORMS PART OF THE COMMON PROPERTY

ALL BALCONY FLOOR COVERINGS FORM PART OF THEIR RESPECTIVE LOT

ALL SERVICE DUCTS, CABLES, PIPES & CONDUITS FORM PART OF THE COMMON PROPERTY

AREAS ARE APPROXIMATE ONLY SHOWN FOR THE PURPOSES OF THE STRATA SCHEMES (FREEHOLD DEVELOPMENT) ACT 1973

Surveyor: JOHN WALTON
 Surveyor's Ref: 750-09 (RES)
 Subdivision No:

Registered

DRAFT
AUG-2011

SP

Lengths are in metres Reduction Ratio 1 : 200



LEVEL 11

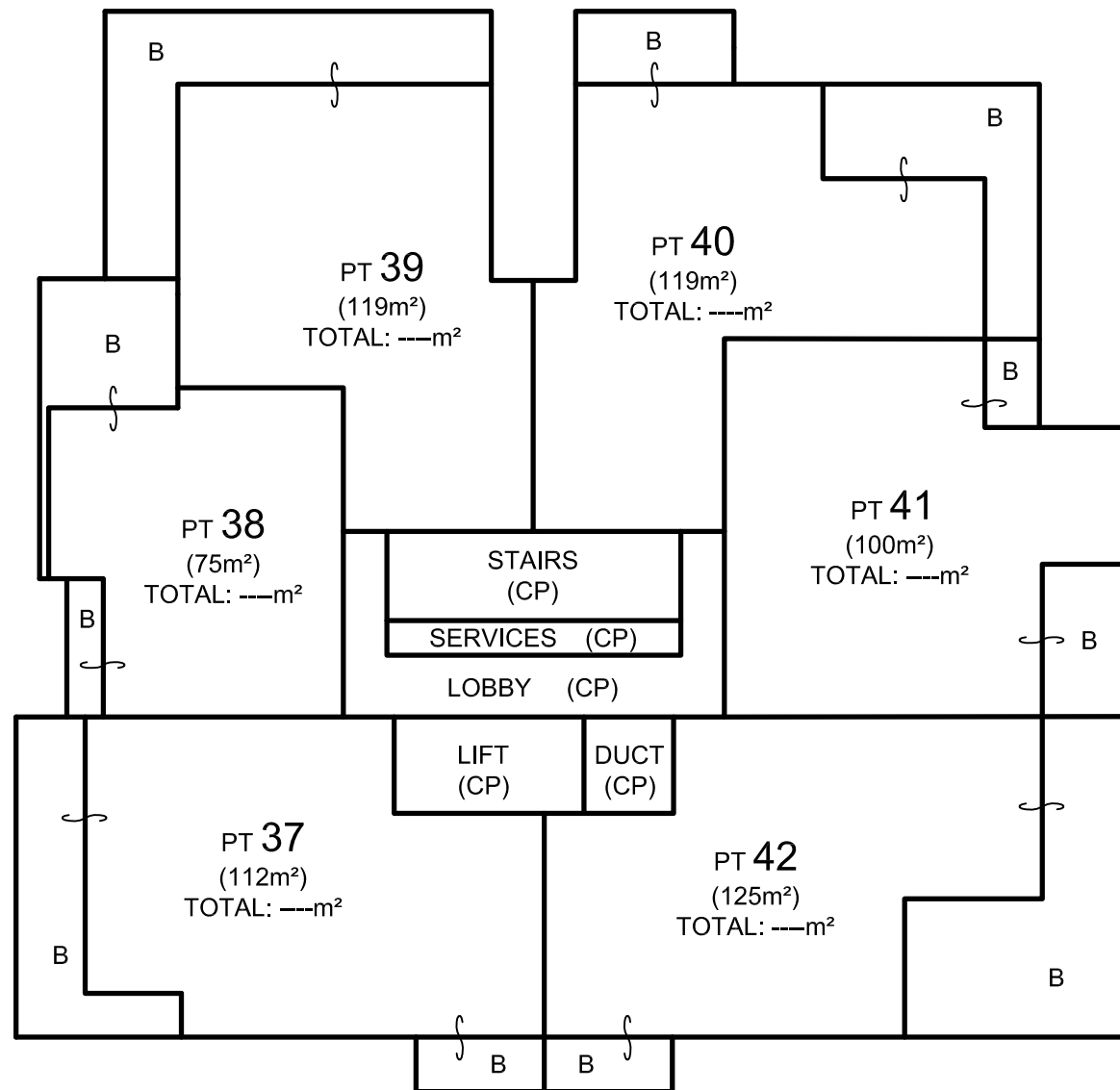

LEVEL 12

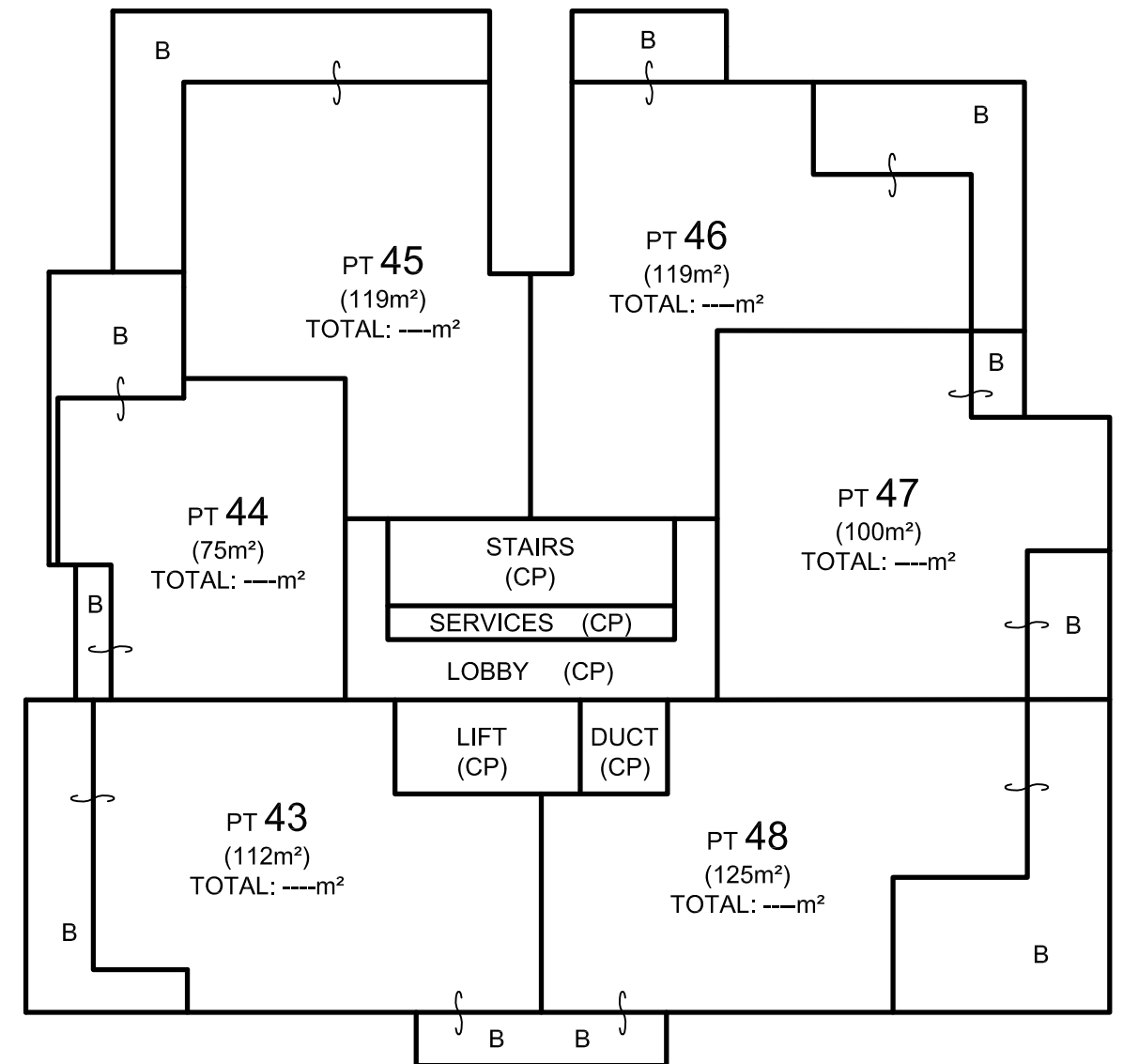

PRELIMINARY PLAN ONLY, SCALED FROM ARCHITECTS PLANS & SUBJECT TO ADDITIONS & ALTERATIONS UPON FINAL SURVEY.

B DENOTES BALCONY HAVING A CONCRETE SURFACE AND IS COVERED

CP DENOTES COMMON PROPERTY

ALL WATER PROOFING FORMS PART OF THE COMMON PROPERTY

ALL BALCONY FLOOR COVERINGS FORM PART OF THEIR RESPECTIVE LOT

ALL SERVICE DUCTS, CABLES, PIPES & CONDUITS FORM PART OF THE COMMON PROPERTY

AREAS ARE APPROXIMATE ONLY SHOWN FOR THE PURPOSES OF THE STRATA SCHEMES (FREEHOLD DEVELOPMENT) ACT 1973

Surveyor: JOHN WALTON
 Surveyor's Ref: 750-09 (RES)
 Subdivision No:

Registered

DRAFT
AUG-2011

SP

Lengths are in metres Reduction Ratio 1 : 200

10	20	30	40	50	Table of mm	90	100	110	120	130	140	150
----	----	----	----	----	-------------	----	-----	-----	-----	-----	-----	-----



LEVEL 13

LEVEL 14

PRELIMINARY PLAN ONLY, SCALED FROM ARCHITECTS PLANS & SUBJECT TO ADDITIONS & ALTERATIONS UPON FINAL SURVEY.

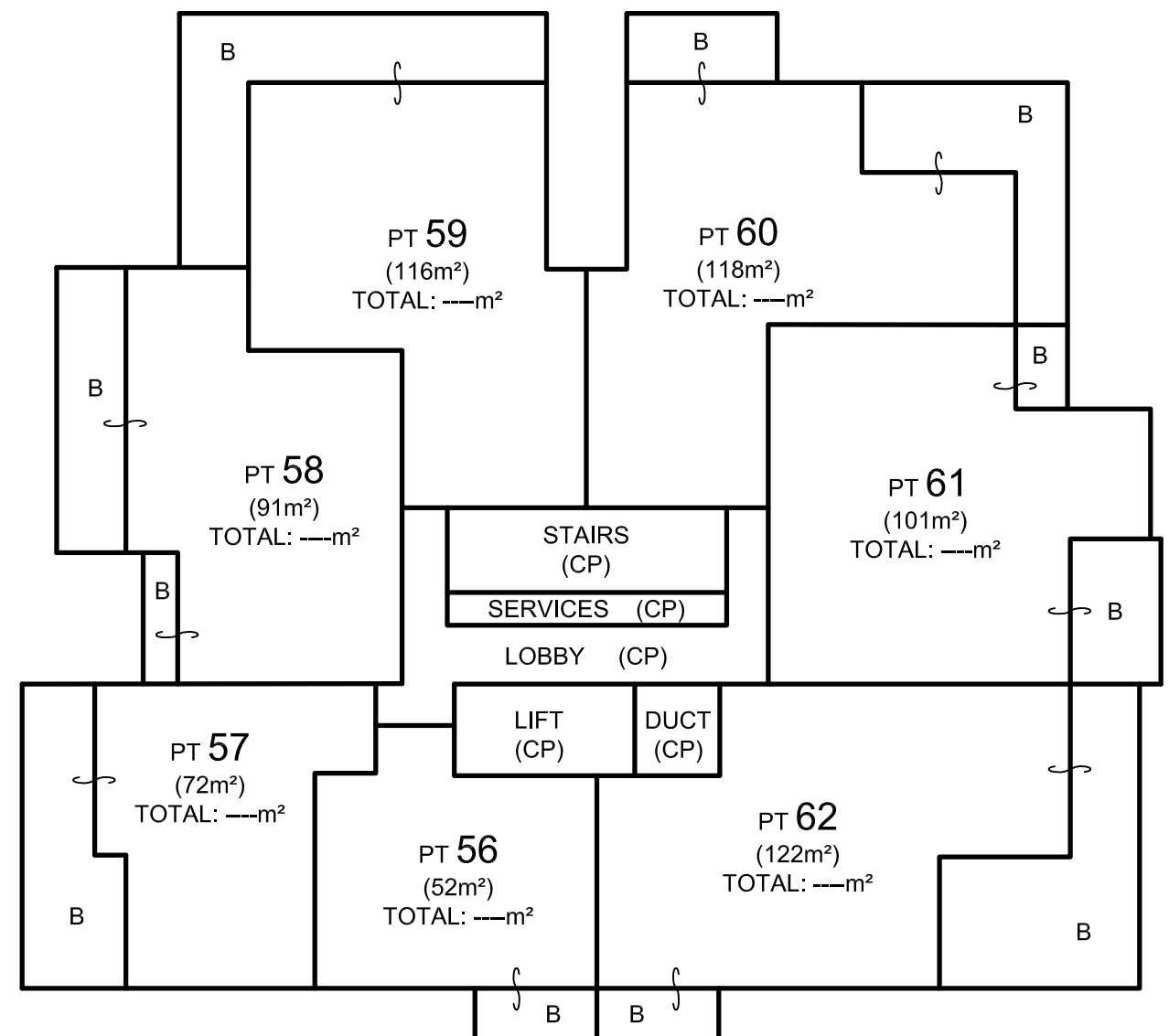
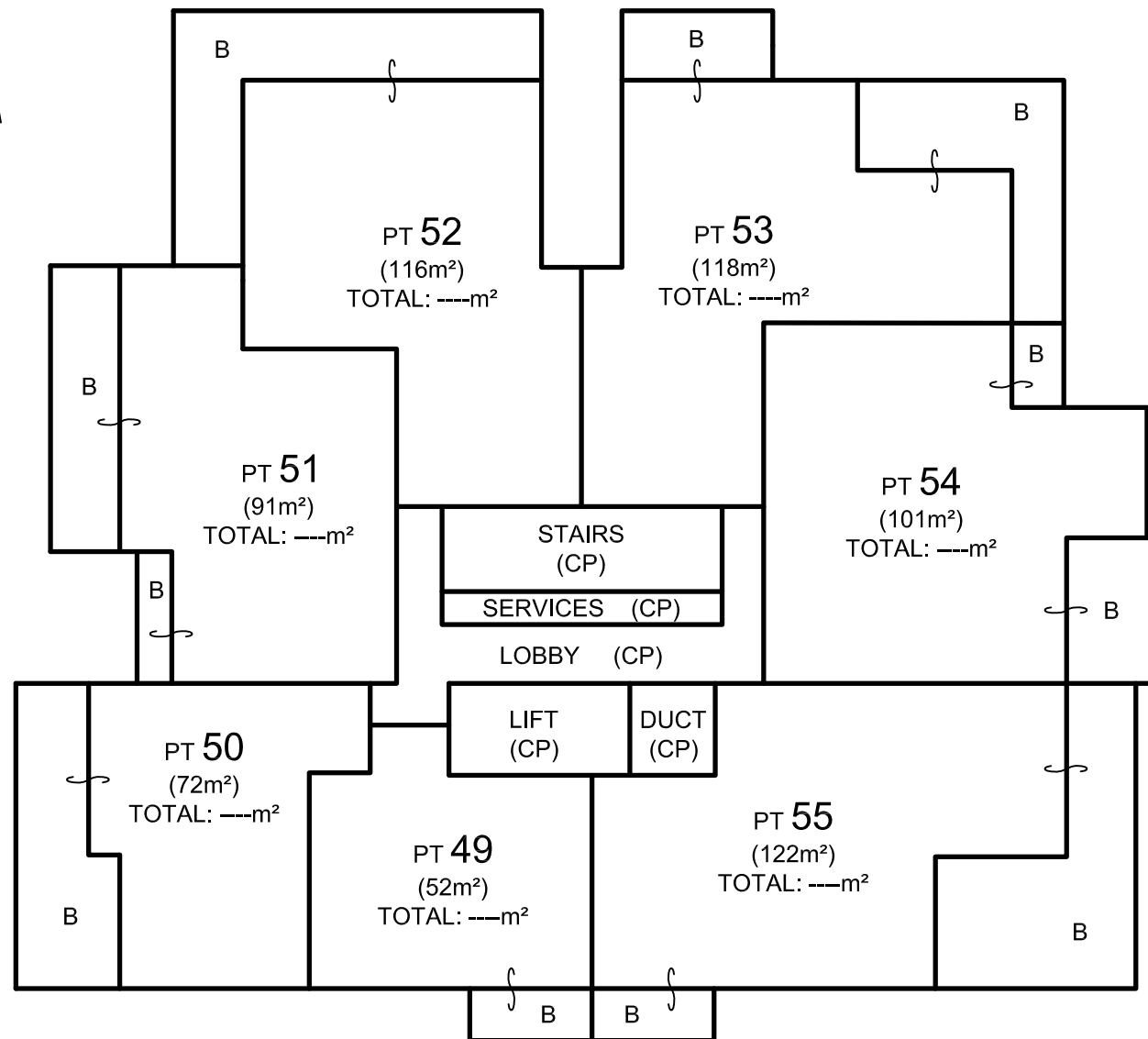

B DENOTES BALCONY HAVING A CONCRETE SURFACE AND IS COVERED

CP DENOTES COMMON PROPERTY

ALL WATER PROOFING FORMS PART OF THE COMMON PROPERTY

ALL BALCONY FLOOR COVERINGS FORM PART OF THEIR RESPECTIVE LOT

ALL SERVICE DUCTS, CABLES, PIPES & CONDUITS FORM PART OF THE COMMON PROPERTY

AREAS ARE APPROXIMATE ONLY SHOWN FOR THE PURPOSES OF THE STRATA SCHEMES (FREEHOLD DEVELOPMENT) ACT 1973

Surveyor: JOHN WALTON
 Surveyor's Ref: 750-09 (RES)
 Subdivision No:

Registered

**DRAFT
 AUG-2011**

SP

Lengths are in metres Reduction Ratio 1 : 200



LEVEL 15

LEVEL 16

PRELIMINARY PLAN ONLY, SCALED FROM ARCHITECTS PLANS & SUBJECT TO ADDITIONS & ALTERATIONS UPON FINAL SURVEY.

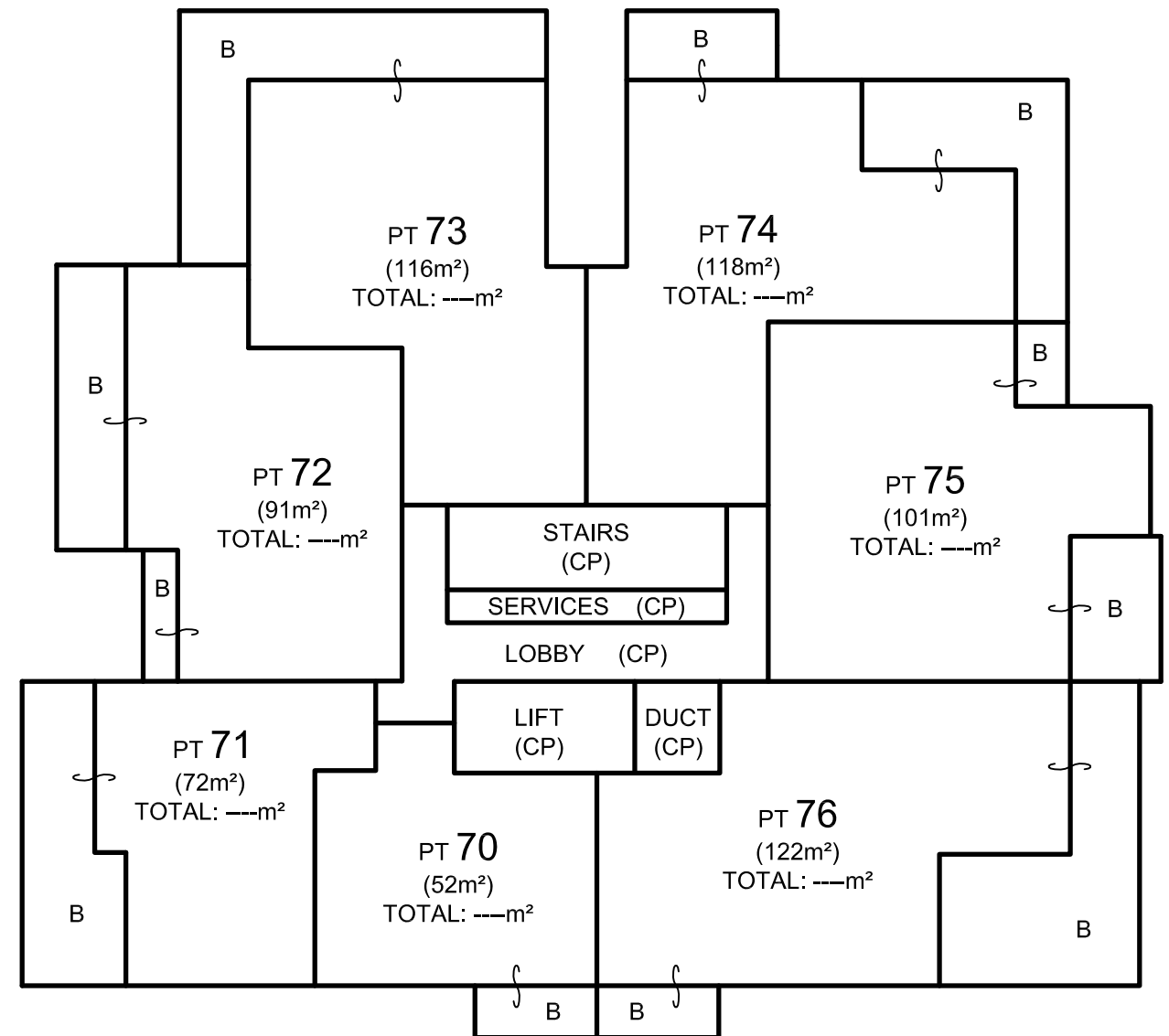
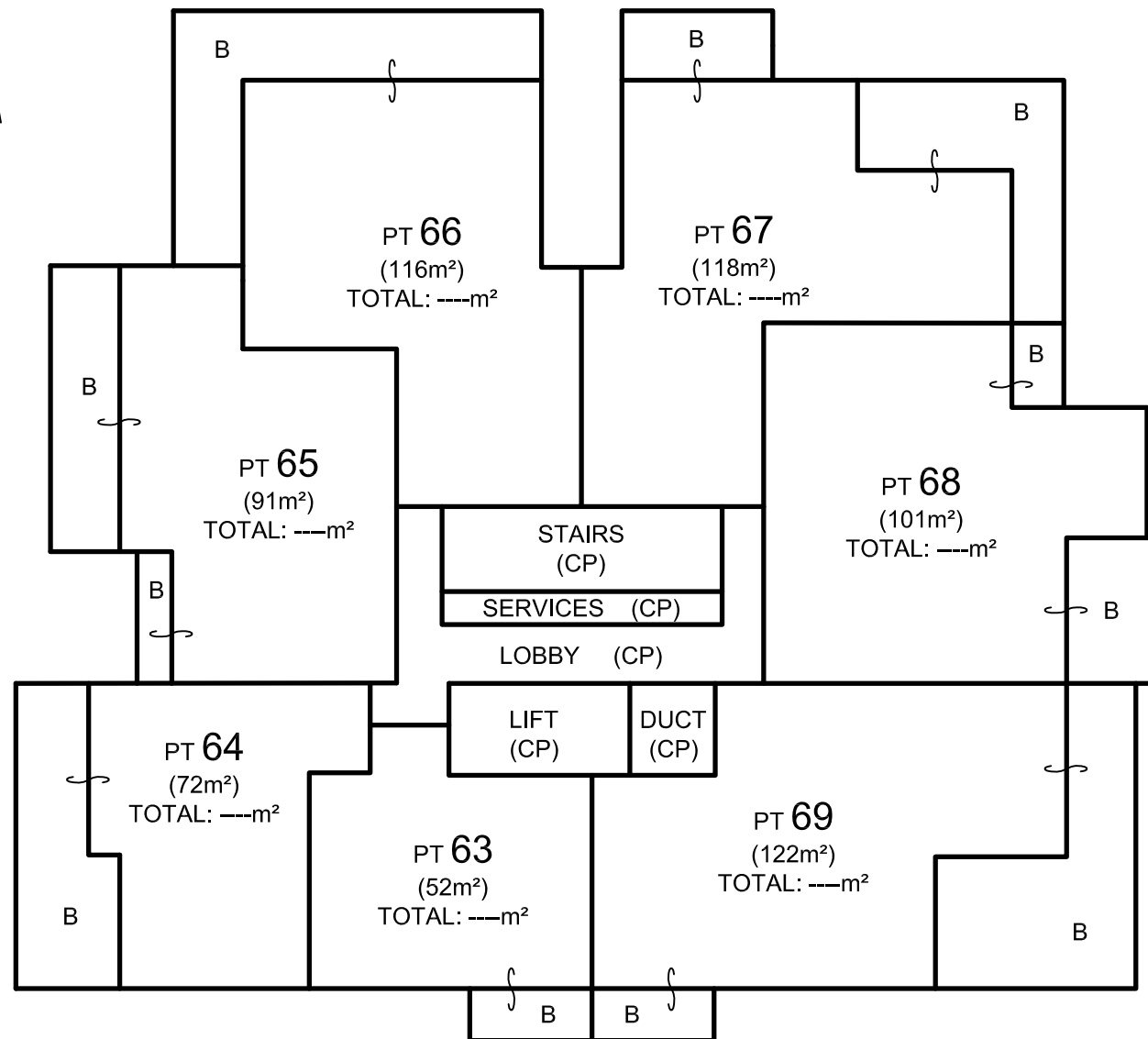

B DENOTES BALCONY HAVING A CONCRETE SURFACE AND IS COVERED

CP DENOTES COMMON PROPERTY

ALL WATER PROOFING FORMS PART OF THE COMMON PROPERTY

ALL BALCONY FLOOR COVERINGS FORM PART OF THEIR RESPECTIVE LOT

ALL SERVICE DUCTS, CABLES, PIPES & CONDUITS FORM PART OF THE COMMON PROPERTY

AREAS ARE APPROXIMATE ONLY SHOWN FOR THE PURPOSES OF THE STRATA SCHEMES (FREEHOLD DEVELOPMENT) ACT 1973

Surveyor: JOHN WALTON
 Surveyor's Ref: 750-09 (RES)
 Subdivision No:

Lengths are in metres Reduction Ratio 1 : 200

Registered

**DRAFT
 AUG-2011**

SP



LEVEL 17

LEVEL 18

PRELIMINARY PLAN ONLY, SCALED FROM ARCHITECTS PLANS & SUBJECT TO ADDITIONS & ALTERATIONS UPON FINAL SURVEY.

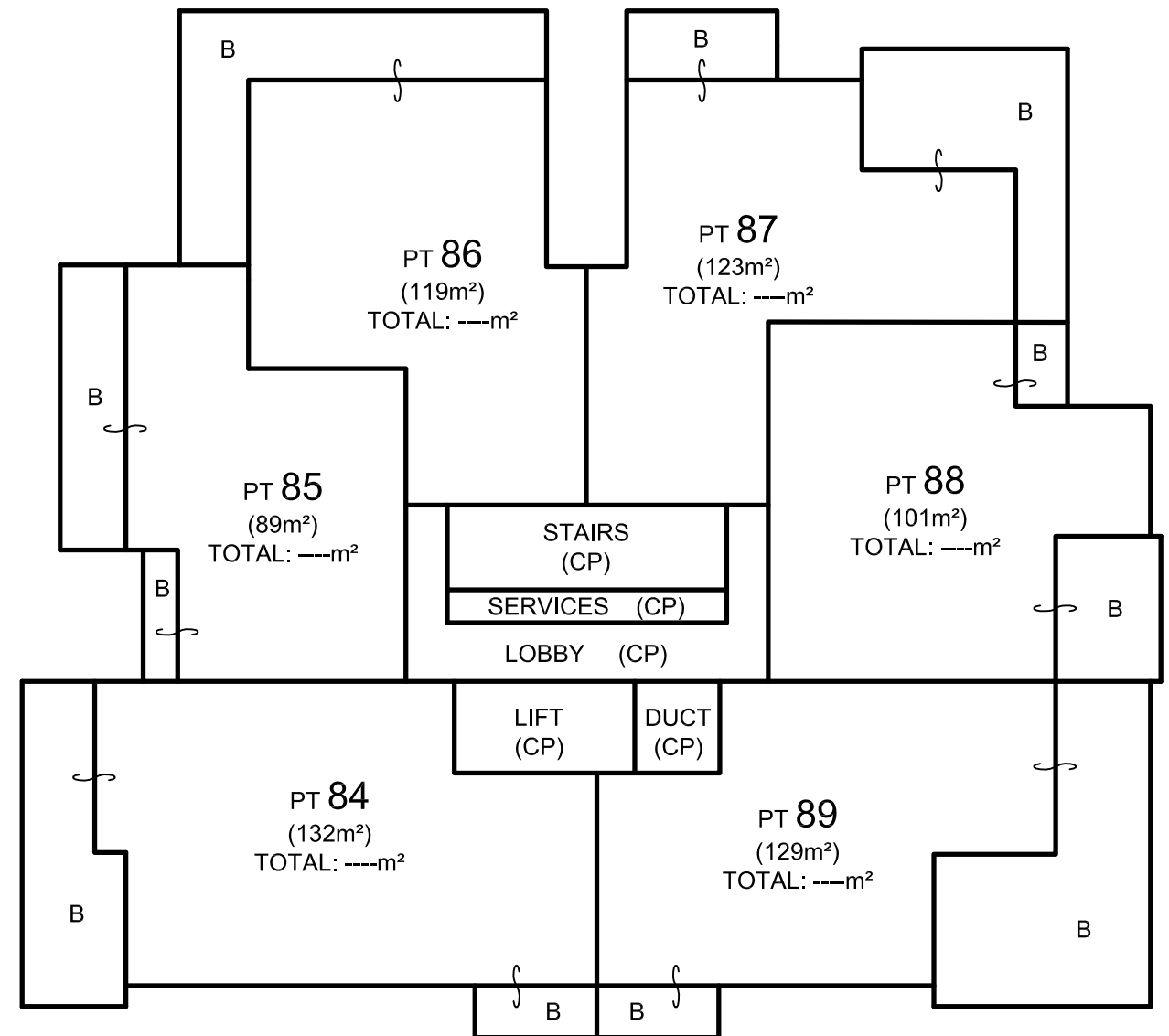
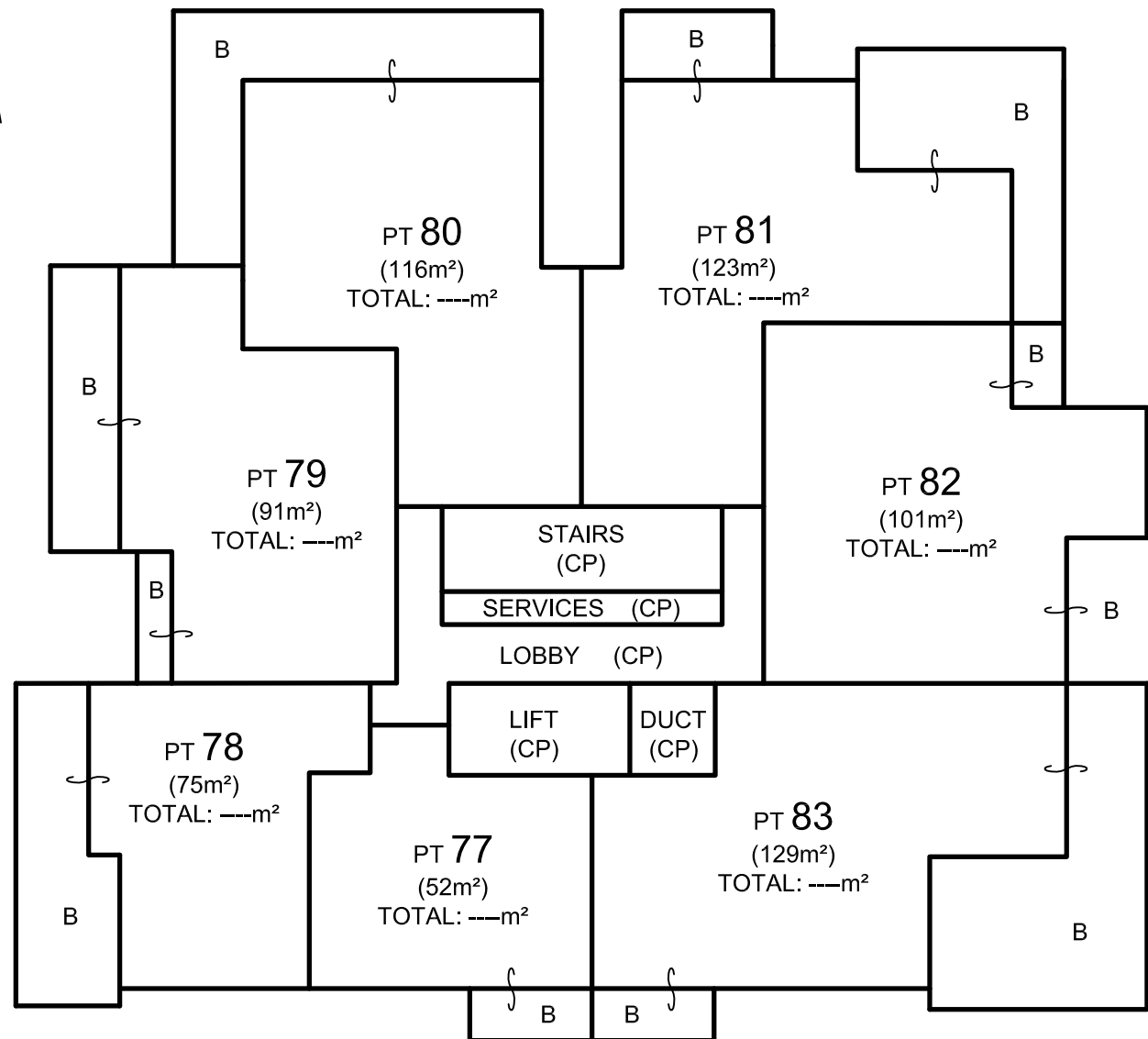

B DENOTES BALCONY HAVING A CONCRETE SURFACE AND LIMITED IN HEIGHT TO 5m ABOVE CONCRETE SURFACE, EXCEPT WHERE COVERED

CP DENOTES COMMON PROPERTY

ALL WATER PROOFING FORMS PART OF THE COMMON PROPERTY

ALL BALCONY FLOOR COVERINGS FORM PART OF THEIR RESPECTIVE LOT

ALL SERVICE DUCTS, CABLES, PIPES & CONDUITS FORM PART OF THE COMMON PROPERTY

AREAS ARE APPROXIMATE ONLY SHOWN FOR THE PURPOSES OF THE STRATA SCHEMES (FREEHOLD DEVELOPMENT) ACT 1973

Surveyor: JOHN WALTON
 Surveyor's Ref: 750-09 (RES)
 Subdivision No:

Registered

DRAFT
AUG-2011

SP

Lengths are in metres Reduction Ratio 1 : 200



ROOF TERRACES

PRELIMINARY PLAN ONLY, SCALED FROM ARCHITECTS PLANS & SUBJECT TO ADDITIONS & ALTERATIONS UPON FINAL SURVEY.

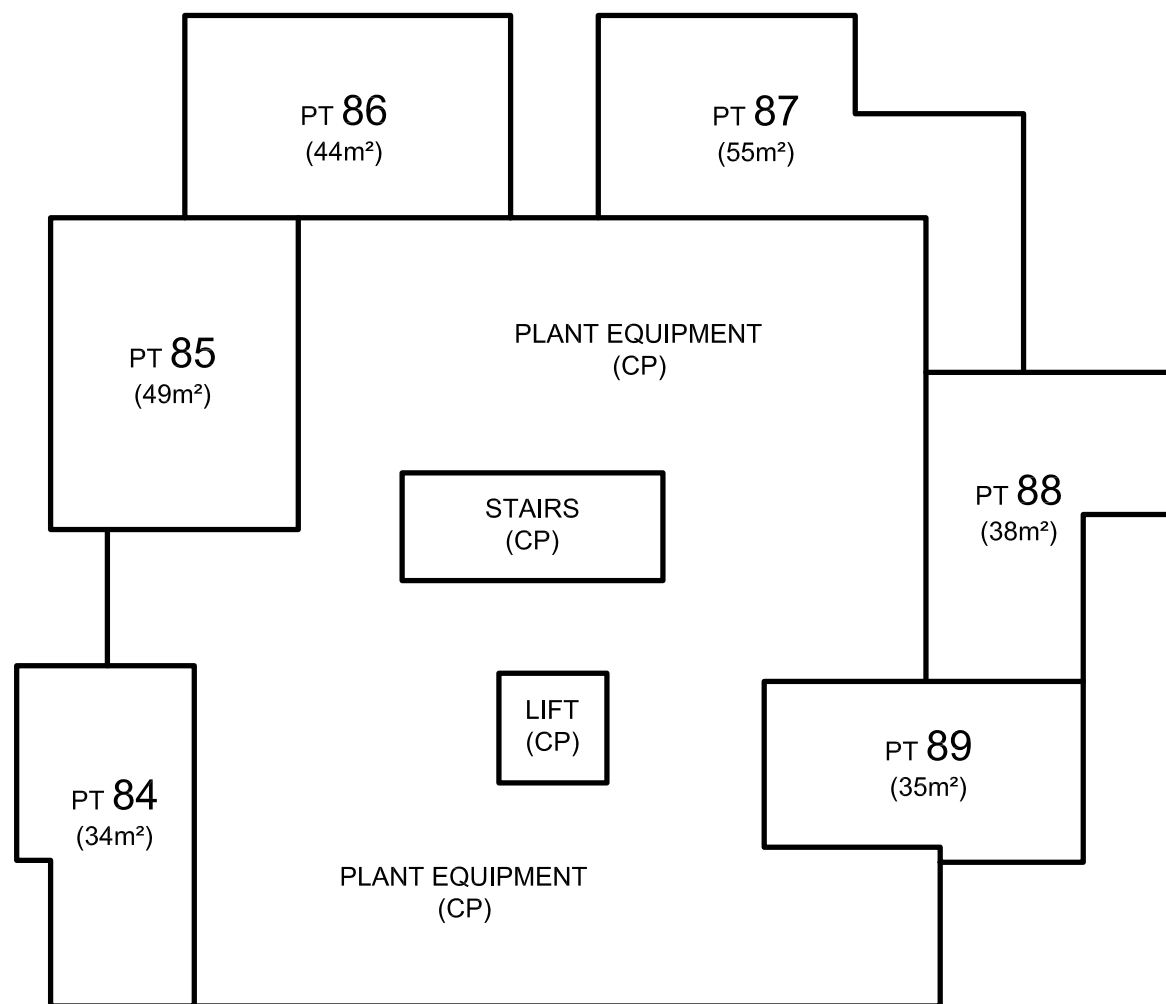

CP DENOTES COMMON PROPERTY

T DENOTES TERRACE HAVING A CONCRETE SURFACE AND LIMITED IN HEIGHT TO 3m ABOVE CONCRETE SURFACE

ALL WATER PROOFING FORMS PART OF THE COMMON PROPERTY

ALL TERRACE FLOOR COVERINGS FORM PART OF THEIR RESPECTIVE LOT

AREAS ARE APPROXIMATE ONLY SHOWN FOR THE PURPOSES OF THE STRATA SCHEMES (FREEHOLD DEVELOPMENT) ACT 1973

Surveyor: JOHN WALTON
 Surveyor's Ref: 750-09 (RES)
 Subdivision No:

Lengths are in metres Reduction Ratio 1 : 200

Registered

**DRAFT
 AUG-2011**

SP