

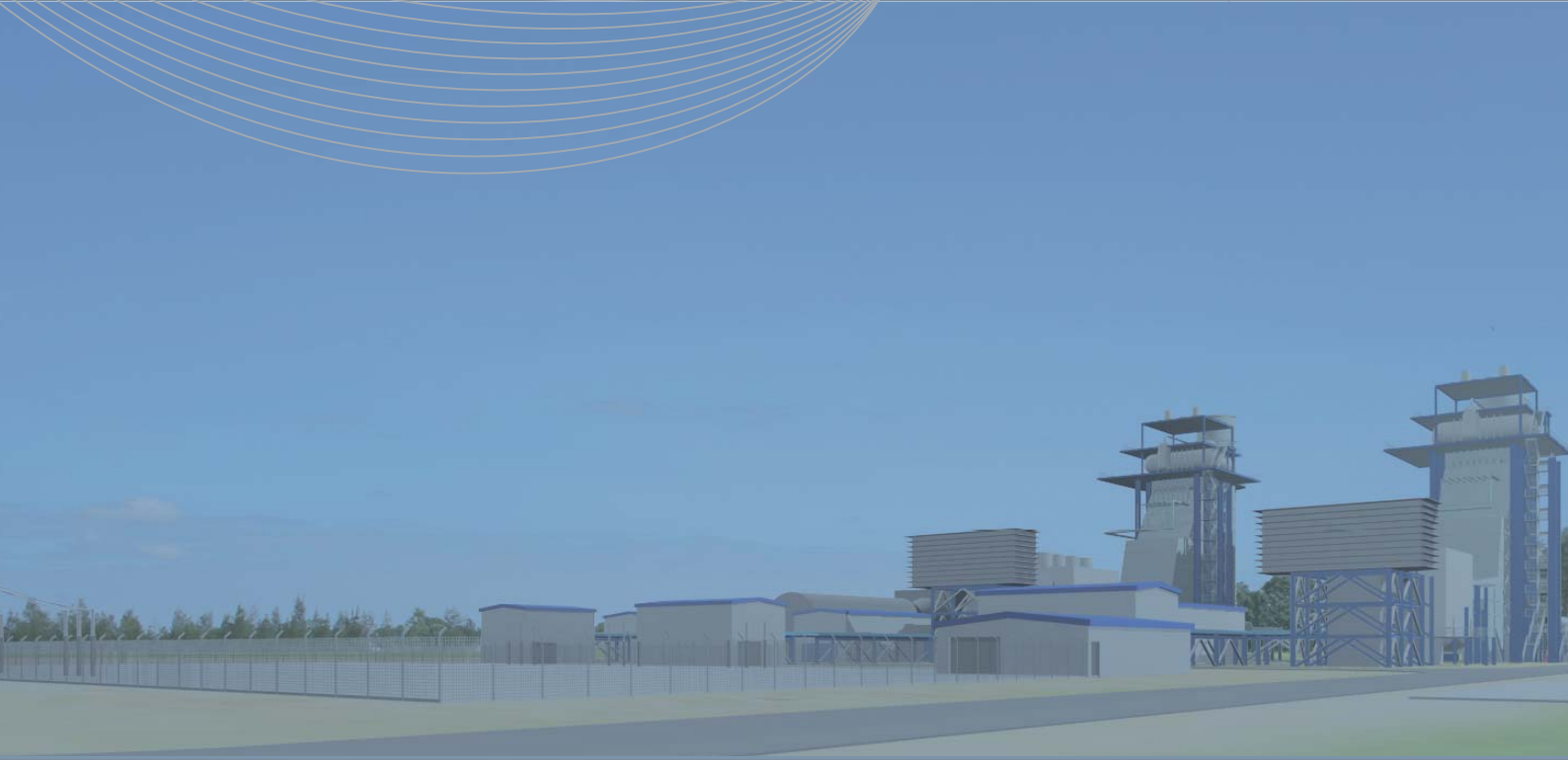

CLIENTS | PEOPLE | PERFORMANCE

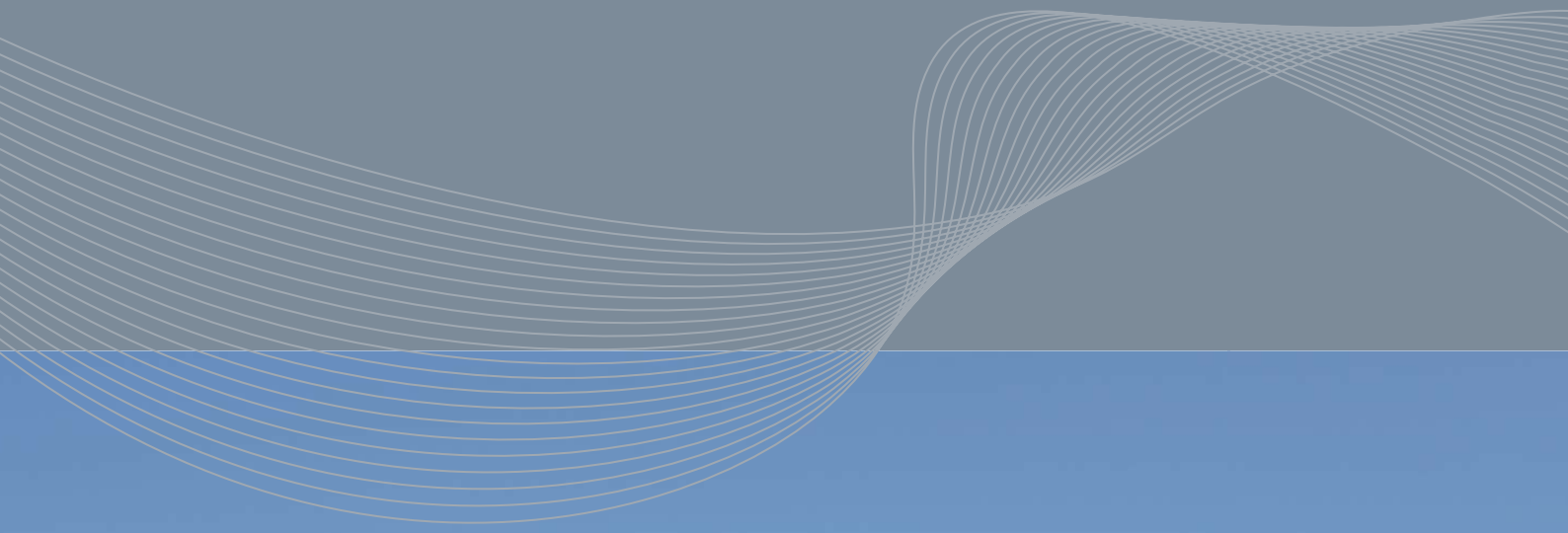

Appendix B

Stability studies (HMA Consulting)



Wednesday, 20 July 2005

Report to:



Stability Studies for the 400MW Combined Cycle Gas Turbine Power Station at Bamarang – Rev. A

Prepared By
Peer Reviewed By:
HMAC Ref#
Client Ref#

Chris Knightly and
Teck Wai Chan
Max Michael
1646
GHD

Head Office – Brisbane

L4, River Quarter
46 Edward St.
(GPO Box 3195)
BRISBANE Qld 4001
p: +61 (0)7 3236 4244
f: +61 (0)7 3236 4266
e: hmac@hmac.com.au

Regional Office – NSW & ACT

PO Box 1375
TUGGERANONG Act 2901
p: +61 (0)2 6292 4315
f: +61 (0)2 6292 9414
e: nsw@hmac.com.au

Townsville Office

PO Box 999
AITKENVALE Qld 4814
p: +61 (0) 4725 1455
f: +61 (0) 4728 6828
e: nq@hmac.com.au

Melbourne Office

p: +61 (0)408 509 161
e: vic@hmac.com.au

Executive Summary

Delta Electricity proposes the installation of a 400MW Combined Cycle Gas Turbine Power Station located at Bamarang in southern NSW. The power station will consist of two gas sets and one steam set generating at 14.5kV.

The objective of this stability study is to ascertain the ability of the generators to comply with the S5.2.5.3 of the National Electricity Rules (NER), which took effect from 1st July 2005, and to withstand other disturbances on the system.

The minimum standards with NEMMCO will be for the generator to remain on line following the clearing of a 2-phase-to-ground fault at the Dapto 132kV transmission level in 120ms. The critical clearing time for this fault location under light load conditions was found to be greater than 430ms which well exceeds NEMMCO's minimum requirements. The critical clearing time for a 3-phase fault is 250ms for the generators. The critical clearing time is the maximum duration of the fault before stability is lost. An IEEE Type 1 AVR with the provided settings was used in the stability studies to yield satisfactory results.

The steam set, being a lighter set, became unstable first with the 2 gas sets following closely. This formed a basis in determining the critical clearing time for the Bamarang Power Station. As the 400MW Tallawarra Power Station was found to have a lower critical clearing time than the steam set in Bamarang, its stability determined the critical clearing time for 132kV faults at Dapto.

The stability studies undertaken were based on peak and light load conditions. Studies on disturbances throughout the system were carried out for both 3-phase and 2-phase-to-ground faults at Shoalhaven and Bamarang. The critical clearing time under light load conditions for 3-phase and 2-phase-to-ground faults at Shoalhaven, followed with clearing one of the lines between Shoalhaven and Mt Terry are 190ms and 370ms respectively. For faults at Bamarang followed with clearing one of the Bamarang to Shoalhaven lines, the critical clearing times are 210ms and 340ms respectively.

In our opinion, as the steam set becomes unstable before the 2 gas sets, out-of-step protection with appropriate settings may be used to prevent all sets being tripped by just tripping the steam set first. However, as critical clearing times are well in excess of normal clearing time, it is unlikely that any out-of-step operation will occur.

Runback facilities are required to be provided for the Power Station to reduce export following loss of a Bamarang-Shoalhaven or Shoalhaven-Mt Terry line respectively, to prevent overloading of the remaining circuit. Negotiation with

Bamarang CCGT Stability Studies

Integral Energy is necessary to determine when runback is necessary, and by how much.

Voltage dip due to contingency at the Power Station was investigated. The tripping of a gas set or a gas set with a steam set imposes no serious dipping of voltage at customer load in the system.

In conclusion, the stability of the 400MW CCGT Power Station as presently planned is satisfactory. It exceeds NEMMCO's minimum requirements and will survive faults in the system near the Power Station. Appropriate runback facilities would be required.

Table of Contents

Executive Summary	2
Table of Contents	4
List of Figures.....	5
List of Tables	5
1. Introduction	6
2. Stability Studies	6
2.1. Scope of Studies	6
2.2. System Modelling Data.....	7
2.3. Steady State Power Flow Study.....	9
2.4. Stability Studies to investigate the generators conformance to the NER.....	18
2.5. Stability Studies for Faults on other parts of the network	22
2.5.1. Fault on Shoalhaven-Mt Terry line near Shoalhaven.....	22
2.5.2. Fault on Bamarang-Shoalhaven line near Bamarang	23
2.6. Summary.....	24
3. Generator Power Output Runback	24
4. Effect of voltage dip at critical load due to the tripping of Bamarang Power Station	24
4.1. Loss of a Single Gas Turbine.....	26
4.2. Loss of a Single Gas Turbine plus the Steam Set.....	26
5. Conclusion.....	27
Appendix	28
Appendix A: Network Data.....	29
Appendix B: Generator Data.....	36
Appendix C: AVR Block Diagram	38
Appendix D: Email from Integral Energy	39

List of Figures

Figure 1: Network Diagram modelled in DINIS.....	8
Figure 2: Response of the steam set at the 400MW Bamarang Power Station under peak load conditions, subject to a 120ms 2-phase-to-ground fault at Dapto 132kV Busbar.	20
Figure 3: Response of the steam set at the 400MW Bamarang Power Station under light load conditions, subject to a 120ms 2-phase-to-ground fault at Dapto 132kV Busbar.	21
Figure 4: Block Diagram IEEE Type 1 AVR.....	38

List of Tables

Table 1: Table of Abbreviations.....	9
Table 2: Generator and Load Power Load Flow Data (Peak Load).....	10
Table 3: Line Flow (Peak Load).....	11
Table 4: Transformers (Peak Load).....	13
Table 5: Generator and Load Power Load Flow Data (Light Load)	14
Table 6: Line Flow (Light Load).....	15
Table 7: Transformers (Light Load)	17
Table 8: Summary of faults at Dapto 132kV	18
Table 9: Summary of faults at Shoalhaven 132kV.....	22
Table 10: Summary of faults at Bamarang 132kV	23
Table 11: Summary of stability study results	24
Table 12: Summary of voltage dip at 33kV Moruya North bus (Single Gas Set)	26
Table 13: Summary of voltage dip at 33kV Moruya North bus (Single Gas & Steam Set)	26
Table A 1: Generators and Motors	29
Table A 2: Transformers.....	30
Table A 3: Control Transformers	32
Table A 4: Transmission Network.....	33
Table A 5: Source Impedance (%100MVABase).....	35
Table B 1: Generator Dynamic Data	36
Table B 2: AVR Dynamic Data (Applicable for the Bamarang Generators)...	37

Bamarang CCGT Stability Studies

1. Introduction

Delta Electricity proposes the development of a 400MW CCGT Power Station to be located at Bamarang in southern NSW. The Power Station consists of 2 gas and 1 steam sets. The generators will be connected to Integral Energy's 132kV sub-transmission substation at Shoalhaven through two 132kV/197MVA transmission lines approximately 7km in length.

HMA Consulting has been engaged to provide technical assistance to GHD for the connection of the Bamarang 400MW CCGT Power Station to the Integral Network.

As a consequence the following studies were undertaken:

- a) Investigation into the capabilities of the 2 gas and 1 steam sets to withstand a 120ms 2-phase-to-ground fault at the Dapto 132kV Busbar, to satisfy NEMMCO's minimum requirements.
- b) Investigation into the impact of the sets to withstand other faults on Integral Energys' 132kV network.
- c) Investigation into the voltage changes on the system following loss of generators.
- d) Investigation into the need for generation output runback following loss of a connecting 132kV circuit.

The study has considered the influence of a 400MW Power Station located at Tallawarra and connected to a T-junction on two of the Dapto-Spring Hill lines.

2. Stability Studies

2.1. Scope of Studies

Stability studies have been carried out for faults at; (1) Dapto 132kV Busbar, clearing one of the Dapto-Tee lines, (2) Shoalhaven, clearing one of the Shoalhaven-Mt Terry 132kV lines, and (3) Bamarang, clearing one of the Bamarang-Shoalhaven 132kV lines.

Studies carried out at the first location are necessary to meet NEMMCO's requirement, as defined in S5.2.5.3 of The National Electricity Rules (NER), which took effect from 1st July 2005.

For all locations listed above, 3-phase faults and 2-phase-to-ground faults were considered for both peak and light load conditions. The peak load conditions have been based on Integral Energy's winter/summer demand forecast for the year 2014. The light load conditions were then modelled

Bamarang CCGT Stability Studies

based on 40% of peak load, excluding BlueScope which remains at peak value.

2.2. System Modelling Data

DINIS network analysis software was used to conduct the studies. The following models were used for the generators at the Bamarang Gas Turbine Powers Station:

- The generators at Bamarang were represented by Full-Park's Equations.
- AVRs were represented by IEEE Type 1 model. AVR settings used in the study are shown in Table B2 (Appendix B) with block diagram shown in Appendix C.
- Governors were not modelled, as they are not expected to affect the stability of the generators or the voltage responses of the system.

The 400MW Tallawarra Power Station was represented with Full-Park's Equations, using typical data of a 400MW generator. An IEEE Type 2 AVR model with typical settings was used.

The 132kV Integral Energy network was fully represented based on the data received from Integral Energy.

The Dapto 330kV network connected at the 132kV Dapto Substation was represented with constant voltage behind the source impedance at the 330kV Dapto bus.

Bamarang CCGT Stability Studies

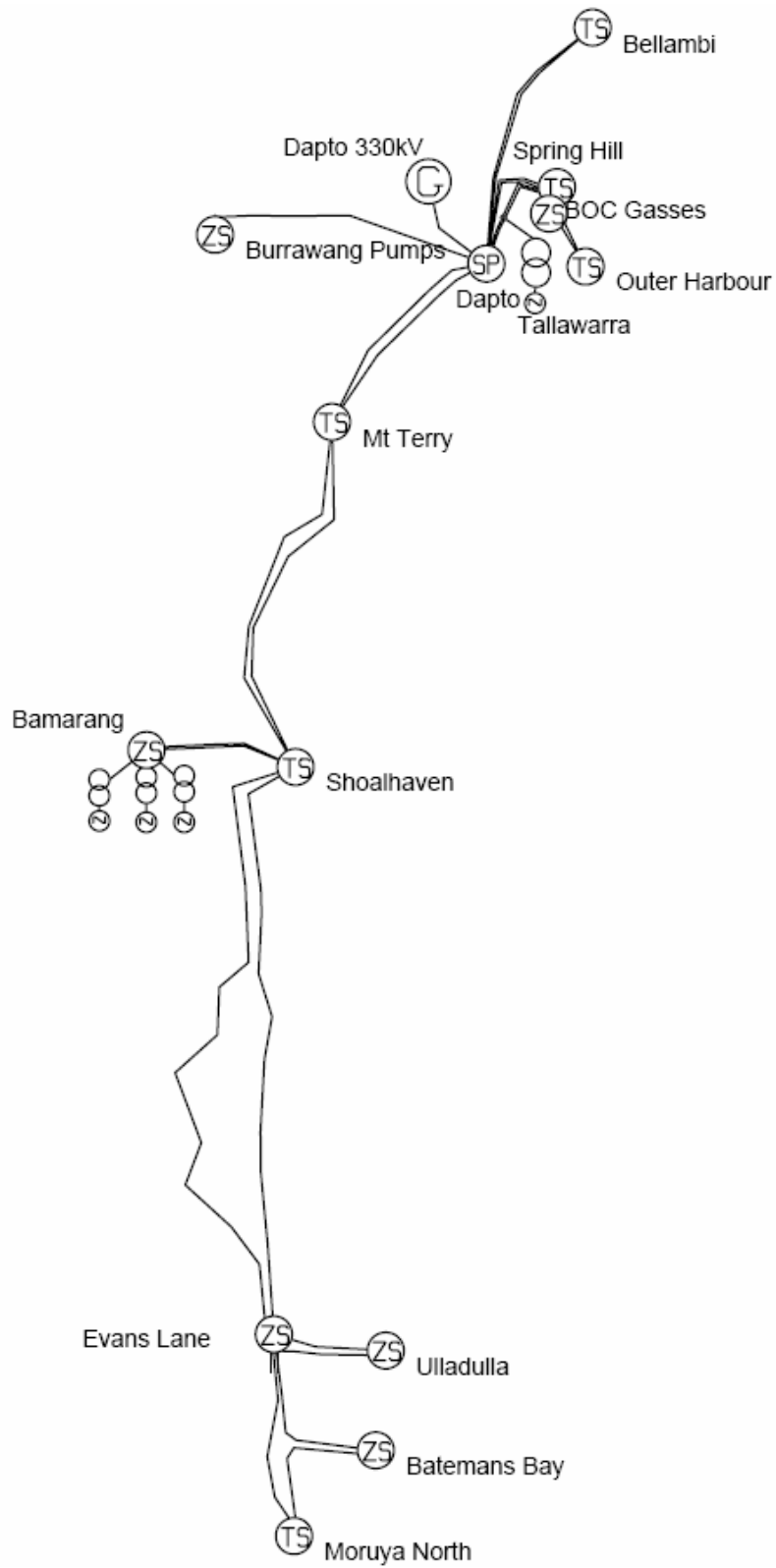

Figure 1: Network Diagram modelled in DINIS

2.3. Steady State Power Flow Study

Steady state power flow studies for the system as shown in Figure 1 were performed considering the full capacity output from the Bamarang 400MW CCGT Power Station. These were done for peak and light load conditions to provide initial conditions for the stability studies.

The power flow solutions for peak and light load conditions are shown in Tables 2 to 7. The network data under which the steady state power flows were performed are shown in Tables A1 to A4 and Tables B1, B2.

Table 1: Table of Abbreviations

BB	Batemans Bay
BLB	Bellambi
BM	Bamarang
BOG	BOC Gasses
BP	Burrawang Pumps
DT	Dapto
DT330	Dapto 330kV
EL	Evans Lane
G_TW	Tallawarra
MN	Moruya North
MT	Mt Terry
OH	Outer Harbour
SH	Shoalhaven
SPH	Spring Hill
UL	Ulladulla
local	Local load
G	Generator
Cap	Capacitor
Tx	Transformer

Bamarang CCGT Stability Studies

Table 2: Generator and Load Power Load Flow Data (Peak Load)

Location	Bus Type	Type	Rating (MVA)	Bus Phase Angle (Degs)	Bus Voltage Magnitude (PU)	Real Load (MW)	Reactive Load (MVAr)	Real Infeed (MW)	Reactive Infeed (MVAr)
BMlocal	PQ	LD	0.1	1.745413	1.000966	14.25	4.68		
G1_BM	PV	GN	178	11.614383	1			140	4.58
G2_BM	PV	GN	178	11.614383	1			140	4.58
G3_BM	PV	GN	178	10.775971	1			120	3.02
BBlocal	PQ	LD	50	-6.044529	1.060137	27.06	4.90		
BLBlocal	PQ	LD	0.1	-8.551967	1.023974	90.73	7.04		
BOGlocal	PQ	LD	50	-8.883116	1.027725	50.00			
BPllocal	PQ	LD	50	-1.266832	1.049763	2.80	2.10		
BlueScope	PQ	LD	240	-7.664117	1.051429	188.08	126.39		
MNlocal	PQ	LD	100	-6.79447	1.04344	32.18	4.58		
OHlocal	PQ	LD	0.1	-4.553868	1.019355	32.46	10.78		
SPHlocal	PQ	LD	0.1	-19.082344	0.997417	175.10			
ULlocal	PQ	LD	0.1	-4.15093	1.032813	31.10	11.90		
DTcap1	PQ	SH	80	-1.168891	1.051529				88.46
DTcap2	PQ	SH	80	-1.168891	1.051529				88.46
SPHcap	PQ	SH	80	-2.154537	1.0361				85.88
G_DT330	Slack	GN	10000	0	1.03			142.95	277.06
G_TW	PV	GN	500	8.597853	1.04			400	-15.62
MTlocal	PQ	LD	150	-7.375885	1.001045	135.00	44.37		
SHlocal	PQ	LD	160	-3.350904	0.992548	140.03	26.93		

Bamarang CCGT Stability Studies

Table 3: Line Flow (Peak Load)

Sending End Location	Sending End Voltage (PU)	Receiving End Location	Receiving End Voltage (PU)	Real Output (MW)	Reactive Output (MVar)	Real Loss (kW)	Reactive Loss (kVAr)	Current (A)
BBTx1	1.060152	BBlocal	1.060137	13.56	2.45	0.17	0.17	682.4627
BBTx2	1.060152	BBlocal	1.060137	13.50	2.45	0.17	0.17	679.0361
BLBTx1	1.024021	BLBlocal	1.023974	45.41	3.55	1.98	-8.51	778.1617
BLBTx2	1.024021	BLBlocal	1.023974	45.32	3.49	1.97	-8.52	776.6235
BOGTx	1.027773	BOGlocal	1.027725	50.00	0.00	2.37	-8.20	2553.524
DT330Tx	1.05183	DT	1.051444	142.54	263.03	80.96	69.90	1244.468
MNTx1	1.043473	MNlocal	1.04344	18.87	15.28	0.54	0.54	407.1391
MNTx2	1.043442	MNlocal	1.04344	13.31	-10.70	0.27	-10.62	286.3875
OHTx1	1.019376	OHlocal	1.019355	16.05	5.08	0.27	-10.12	288.926
OHTx2	1.019377	OHlocal	1.019355	16.40	5.71	0.29	-10.10	298.0055
ULTx1	1.032834	ULlocal	1.032813	15.55	5.95	0.26	0.26	846.1339
ULTx2	1.032834	ULlocal	1.032813	15.55	5.95	0.26	0.26	846.1339
BB	0.917986	BBTx1	0.917967	13.61	3.46	0.23	0.23	66.9081
BB	0.917986	BBTx2	0.917967	13.54	3.44	0.23	0.23	66.57217
BLB	1.042909	BLBTx1	1.042857	45.57	8.63	1.98	-8.90	194.532
BLB	1.042909	BLBTx2	1.042857	45.49	8.56	1.97	-8.91	194.1475
BOG	1.035236	BOGTx	1.035182	50.03	5.81	2.37	-8.35	212.7884
BP	1.049914	BPlocal	1.049763	2.80	2.10	0.20	-119.57	14.28812
MN	0.920295	MNTx1	0.920255	19.16	18.19	0.82	0.82	125.5661
MN	0.920295	MNTx2	0.920291	13.45	-9.18	0.31	0.31	77.40202
OH	1.034872	OHTx1	1.034851	16.08	5.79	0.27	-10.44	72.21618
OH	1.034872	OHTx2	1.03485	16.41	6.45	0.29	-10.42	74.48482
G_TW	1.04	TWTx	1.032894	397.21	-16.96	2791.83	1333.66	20202.46
BB	0.917986	MN	0.920295	2.02	-4.94	16.74	-823.08	29.10997
BM	0.990274	SH	0.987441	191.19	-20.13	1086.54	3436.82	852.4651
BM	0.990274	SH	0.987441	191.19	-20.13	1086.54	3436.82	852.4651
DT	1.051444	DTcap1	1.051529	0.00	-88.46	7.08	-3.98	367.9856
DT	1.051444	DTcap2	1.051529	0.00	-88.46	7.08	-3.98	367.9856
DT	1.051444	BLB	1.042909	45.85	8.64	207.81	-266.31	194.7274
DT	1.051444	BLB	1.042909	45.22	8.53	204.97	-296.64	192.0589
DT	1.051444	SPH	1.036017	73.40	44.28	315.50	1154.94	360.1972
DT	1.051444	SPH	1.036017	73.40	44.28	315.50	1154.94	360.1972
DT	1.051444	BP	1.049914	2.80	1.98	2.20	-1737.84	11.7012

Bamarang CCGT Stability Studies

Table 3(Cont'd): Line Flow (Peak Load)

Sending End Location	Sending End Voltage (PU)	Receiving End Location	Receiving End Voltage (PU)	Real Output (MW)	Reactive Output (MVar)	Real Loss (kW)	Reactive Loss (kVAr)	Current (A)
EL	0.955463	UL	0.953955	16.3231553	7.876839	7.34	-295.16	82.42062
EL	0.955463	MN	0.920295	30.5860645	13.94689	460.45	-1209.58	153.619
EL	0.955463	BB	0.917986	29.1920566	1.141766	1152.83	-747.08	138.9229
EL	0.955463	Node at EL	0.955274	14.9264902	6.826029	1.08	-247.09	74.67686
MT	1.034101	DT	1.051444	3.86474683	-95.39146	263.59	1084.72	399.2645
MT	1.034101	DT	1.051444	3.96606934	-97.43443	268.89	1129.56	407.7275
SH	0.987441	MT	1.034101	71.5972656	-63.93801	1990.99	6766.36	412.7717
SH	0.987441	MT	1.034101	72.12375	-64.68535	2027.71	6857.12	416.5268
SH	0.987441	EL	0.955463	48.2887031	14.1072	743.49	692.30	226.8655
SH	0.987441	EL	0.955463	44.3607695	13.18541	682.59	183.40	208.1218
SPH	1.036017	BOG	1.035236	27.6369746	1.975729	17.90	-137.94	117.0111
SPH	1.036017	Node at BOG	1.035566	34.8495469	8.864197	8.00	-25.75	151.8189
SPH	1.036017	OH	1.034872	20.0334434	6.920596	10.49	-181.20	89.27689
SPH	1.036017	SPHcap	1.0361	0	-85.88028	6.87	-3.86	362.5863
Node at BOG	1.035566	BOG	1.035236	22.3914297	3.83039	4.33	-89.40	95.90242
Node at BOG	1.035566	OH	1.034872	12.4501133	5.300385	3.67	-177.17	56.87737
TWtee1	1.044644	DT	1.051444	46.7335078	-71.35482	121.65	431.66	355.9026
TWtee1	1.044644	SPH	1.036017	150.325656	25.92617	610.46	3253.87	643.6627
TWtee2	1.044644	SPH	1.036017	150.679125	26.04817	610.42	3265.86	645.2221
TWtee2	1.044644	DT	1.051444	44.6189609	-68.0518	115.78	383.96	339.6367
UL	0.953955	ULTx1	0.95393	15.6215313	7.497781	0.33	0.33	79.44919
UL	0.953955	ULTx2	0.95393	15.6215313	7.497781	0.33	0.33	79.44919
Node at EL	0.955274	UL	0.953955	14.9205645	7.119383	5.93	-293.35	75.15055
TWTx	1.04478	TWtee2	1.044644	393.815563	-80.09692	2059.21	9361.41	1683.539

Bamarang CCGT Stability Studies

Table 4: Transformers (Peak Load)

Location	Tfmr Type	Winding Voltage (kV)	Winding Voltage (PU)	Tap Position	Real Output (MW)	Reactive Output (MVA _r)	Real Loss (kW)	Reactive Loss (MVA _r)	Rating (MVA)
BBTx1	2WDG	132	0.917967	17	13.5645	2.454589	45.64868	1.00258	23
		11	1.060152						23
BBTx2	2WDG	132	0.917967	17	13.49583	2.445375	45.19143	0.997559	23
		11	1.060152						23
BLBTx1	2WDG	132	1.042857	5	45.40843	3.541645	166.1759	5.08617	60
		33	1.024021						60
BLBTx2	2WDG	132	1.042857	5	45.32252	3.484898	171.431	5.075935	60
		33	1.024021						60
BMTx1	2WDG	132	0.990274	12	139.6402	-9.86874	359.8034	14.44829	162
		14.5	1						162
BMTx2	2WDG	132	0.990274	12	139.6402	-9.86874	359.8034	14.44829	162
		14.5	1						162
BMTx3	2WDG	132	0.990274	12	119.7039	-7.63447	296.0559	10.65	162
		14.5	1						162
BMTx _{aux}	2WDG	132	0.990274	10	14.25	4.683749	173.0307	1.333336	20
		6.6	1.000966						20
BOGTx	2WDG	132	1.035182		50.00237	-0.0082	23.66937	5.822664	50
		11	1.027773						50
BlueScopeTx	2WDG	132	1.036017	12	188.078	126.3892	959.451	28.97319	300
		33	1.051429						300
DT330Tx	2WDG	330	1.03	17	142.6208	263.1012	324.328	13.9626	1125
		132	1.05183						1125
MNTx1	2WDG	132	0.920255	25	18.86962	15.28368	288.102	2.908098	30
		33	1.043473						30
MNTx2	2WDG	132	0.920291	11	13.30618	-10.7091	144.6941	1.527327	30
		33	1.043442						30
MTTx	2WDG	132	1.034101	12	134.995	44.37071	362.7144	17.61756	240
		33	1.001045						240
OHTx1	2WDG	132	1.034851	5	16.0542	5.065289	23.72694	0.728172	60
		33	1.019376						60
OHTx2	2WDG	132	1.03485	5	16.40217	5.696932	2.901333	0.751445	60
		33	1.019377						60
SHTx	2WDG	132	0.987441	14	140.0332	26.93442	539.7793	19.63447	180
		33	0.992548						180
SPHTx	2WDG	132	1.036017	6	175.1	0	1094.37	53.64077	120
		33	0.997417						120
TWTx	2WDG	11	1.032894		395.8748	-70.7355	1333.392	53.78013	400
		132	1.04478	3					400
ULTx1	2WDG	132	0.95393	14	15.55136	5.948854	70.16953	1.548927	30
		11	1.032834						30
ULTx2	2WDG	132	0.95393	14	15.55136	5.948854	70.16953	1.548927	30
		11	1.032834						30

Bamarang CCGT Stability Studies

Table 5: Generator and Load Power Load Flow Data (Light Load)

Location	Bus Type	Type	Rating (kVA)	Bus Phase Angle (Degs)	Bus Voltage magnitude (PU)	Real Load (MW)	Reactive Load (Mvar)	Real Infeed (MW)	Reactive Infeed (kVAr)
BMlocal	PQ	LD	0.1	9.995051	0.995807	14.25	4.683749512		
G1_BM	PV	GN	178	19.060978	1.01			140	-495.480255
G2_BM	PV	GN	178	19.060978	1.01			140	-495.480255
G3_BM	PV	GN	178	18.289484	1.01			120.0000078	-1908.964111
BBlocal	PQ	LD	50	8.213093	1.047296	10.824	1.95985144		
BLBlocal	PQ	LD	0.1	-0.443577	1.003186	36.2908008	2.817426025		
BOGlocal	PQ	LD	50	-0.652366	1.039312	20			
BPlocal	PQ	LD	50	2.387584	1.049091	1.12	0.84		
BlueScope	PQ	LD	240	-3.46485	1.057249	188.078	126.3891719		
MNlocal	PQ	LD	100	7.983923	1.044147	12.87	1.833874023		
OHlocal	PQ	LD	0.1	1.026114	1.009135	12.9823213	4.312975586		
SPHlocal	PQ	LD	0.1	-4.402915	0.994627	70.04			
ULlocal	PQ	LD	50	8.796546	1.009306	12.4408799	4.758875488		
DTcap1	PQ	SH	80	2.432396	1.049409				88100.73438
DTcap2	PQ	SH	80	2.432396	1.049409				88100.73438
SPHcap	PQ	SH	80	1.988702	1.040941				86684.67188
G_DT330	Slack	GN	10000	0	1.03			-287.89725	96240.53125
G_TW	PV	GN	500	12.567693	1.03			400	17285.99609
MTlocal	PQ	LD	150	1.215813	0.997029	53.998	17.74828711		
SHlocal	PQ	LD	160	9.479825	0.992261	56.0132773	10.77376758		

Bamarang CCGT Stability Studies

Table 6: Line Flow (Light Load)

Sending End Location	Sending End Voltage (PU)	Receiving End Location	Receiving End Voltage (PU)	Real Output (MW)	Reactive Output (MVar)	Real Loss (kW)	Reactive Loss (kVAr)	Current (A)
BBTx1	1.047302	BBlocal	1.047296	5.425731	0.981771	0.0277185	0.0277185	276.332
BBTx2	1.047302	BBlocal	1.047296	5.398261	0.978084	0.0274408	0.0274408	274.9445
BLBTx1	1.003206	BLBlocal	1.003186	18.1887	1.421227	0.3307233	-9.733303	318.1622
BLBTx2	1.003206	BLBlocal	1.003186	18.1021	1.396199	0.3275307	-9.736495	316.6229
BOGTx	1.039331	BOGlocal	1.039312	20	3.7E-08	0.3703122	-10.43159	1010.022
ULTx2	1.009315	ULlocal	1.009306	6.220438	2.379438	0.0435414	0.0435414	346.3362
MNTx1	1.044169	MNlocal	1.044147	8.349015	14.23245	0.249732	0.249732	276.4792
MNTx2	1.04414	MNlocal	1.044147	4.520969	-12.3986	0.1598715	-10.74248	221.299
OHTx1	1.009143	OHlocal	1.009135	6.627126	2.093961	0.047412	-10.1362	120.441
OHTx2	1.009143	OHlocal	1.009135	6.355195	2.219015	0.0444738	-10.13914	116.6459
ULTx1	1.009315	ULlocal	1.009306	6.220438	2.379438	0.0435414	0.0435414	346.3362
BB	1.015156	BBTx1	1.015149	5.433249	1.146148	0.0299204	0.0299204	23.92486
BB	1.015156	BBTx2	1.015149	5.405706	1.141638	0.0296207	0.0296207	23.80473
BLB	1.046744	BLBTx1	1.046725	18.21578	2.191324	0.3072127	-10.64932	76.66015
BLB	1.046744	BLBTx2	1.046725	18.12983	2.162494	0.3042473	-10.65229	76.28927
BP	1.04915	BPlocal	1.049091	1.12	0.84	0.031651	-119.8836	5.551202
BOG	1.040597	BOGTx	1.040576	20.00407	0.900537	0.3703033	-10.4579	84.16645
DT	1.049325	DT330Tx	1.049129	288.2047	-83.0034	81.725	70.71622	1250.389
MN	1.015943	MNTx1	1.015919	8.482141	15.57369	0.3047078	0.3047078	76.34969
MN	1.015943	MNTx2	1.01595	4.607531	-11.4974	0.1486392	0.1486392	53.32517
OH	1.040438	OHTx1	1.04043	6.631189	2.203645	0.0450856	-10.77994	29.36152
OH	1.040438	OHTx2	1.04043	6.355662	2.324991	0.0422865	-10.78274	28.43461
G_TW	1.03	TWTx	1.022536	397.1527	15.92584	2847.278	1360.154	20402.09
BB	1.015156	MN	1.015943	0.585965	-1.36187	1.619778	-1029.237	10.60873
BM	1.033598	SH	1.031686	191.3018	-25.4977	1003.479	2822.669	819.4139
BM	1.033598	SH	1.031686	191.3018	-25.4977	1003.479	2822.669	819.4139
DT	1.049325	DTcap1	1.049409	1.3E-08	-88.1007	7.048939	-3.962771	367.2438
DT	1.049325	DTcap2	1.049409	1.3E-08	-88.1007	7.048939	-3.962771	367.2438
DT	1.049325	BLB	1.046744	18.29789	2.17259	32.11023	-1088.667	76.53778
DT	1.049325	BLB	1.046744	18.04833	2.159927	31.67228	-1107.837	75.48975
DT	1.049325	SPH	1.040858	34.05082	25.83958	77.24244	-303.3563	177.6691
DT	1.049325	SPH	1.040858	34.05082	25.83958	77.24244	-303.3564	177.6691
DT	1.049325	BP	1.04915	1.120032	0.720116	0.3097142	-1738.524	6.310923
EL	1.02616	UL	1.025674	6.514385	2.756023	0.9542788	-393.2955	29.54038
EL	1.02616	MN	1.015943	12.50415	5.438665	58.53624	-3657.239	54.08236
EL	1.02616	BB	1.015156	11.4266	-0.10325	146.5929	-2429.681	50.49673
EL	1.02616	Nod at EL	1.026103	5.950953	2.141127	0.1377311	-290.7003	26.56362
MT	1.041536	DT	1.049325	111.5025	-62.082	471.3008	2336.279	532.976
MT	1.041536	DT	1.049325	113.8909	-63.3938	480.7796	2407.939	544.3118
SH	1.031686	MT	1.041536	139.6092	-49.8075	4625.036	18825.07	625.4343
SH	1.031686	MT	1.041536	140.7882	-50.5616	4710.343	19022.91	631.1712
SH	1.031686	EL	1.02616	19.0767	1.671269	93.98625	-2570.394	81.36411

Bamarang CCGT Stability Studies

Table 6(Cont'd): Line Flow (Light Load)

Sending End Location	Sending End Voltage (PU)	Receiving End Location	Receiving End Voltage (PU)	Real Output (MW)	Reactive Output (MVar)	Real Loss (kW)	Reactive Loss (kVAr)	Current (A)
SH	1.031686	EL	1.02616	17.52559	1.790382	86.2886	-2869.104	74.80607
SPH	1.040858	BOG	1.040597	10.99133	0.042308	2.789231	-177.2119	46.20267
SPH	1.040858	Node at BOG	1.040703	13.98436	2.594229	1.239282	-53.51083	59.73183
SPH	1.040858	OH	1.040438	8.016942	2.463567	1.618405	-218.8054	34.99083
SPH	1.040858	SPHcap	1.040941	1.8E-08	-86.6847	6.935641	-3.899077	364.2804
Node at BOG	1.040703	BOG	1.040597	9.013115	0.847771	0.6804274	-105.4979	38.01141
Node at BOG	1.040703	OH	1.040438	4.969997	2.043507	0.5684819	-191.5502	22.29317
TWtee1	1.046407	DT	1.049325	86.31705	-41.7181	154.0407	629.1935	400.1696
TWtee1	1.046407	SPH	1.040858	111.9359	14.55922	331.1534	1548.706	474.0696
TWtee2	1.046407	SPH	1.040858	112.2011	14.63807	331.134	1556.477	475.2181
TWtee2	1.046407	DT	1.049325	82.37652	-39.7583	146.6161	572.4663	381.8507
UL	1.025674	ULTx1	1.025665	6.232242	2.638975	0.0435414	0.0435414	28.86134
UL	1.025674	ULTx2	1.025665	6.232242	2.638975	0.0435414	0.0435414	28.86134
Node at EL	1.026103	UL	1.025674	5.950179	2.522019	0.7723267	-380.892	26.95847
TWTx	1.048706	TWtee2	1.046407	393.7935	-47.9722	1999.348	9049.857	1658.706

Bamarang CCGT Stability Studies

Table 7: Transformers (Light Load)

Location	Tfmr type	Winding Voltage (kV)	Winding Voltage (PU)	Tap Position	Real Output (MW)	Reactive Output (MVar)	Real Loss (kW)	Reactive Loss (kVAr)	Rating (kVA)
BBTx1	2WDG	132	1.015149	8	5.42576	0.981783	7.484	0.16437	23
		11	1.047302						23
BBTx2	2WDG	132	1.015149	8	5.39829	0.978096	7.409	0.16355	23
		11	1.047302						23
BLBTx1	2WDG	132	1.046725	2	18.189	1.411494	26.747	0.77983	60
		33	1.003206						60
BLBTx2	2WDG	132	1.046725	2	18.1024	1.386462	27.401	0.77603	60
		33	1.003206						60
BMTx1	2WDG	132	1.033598	9	139.656	-13.8403	343.64	13.3448	162
		14.5	1.01						162
BMTx2	2WDG	132	1.033598	9	139.656	-13.8403	343.64	13.3448	162
		14.5	1.01						162
BMTx3	2WDG	132	1.033598	9	119.715	-11.7565	284.95	9.84753	162
		14.5	1.01						162
BMTxaux	2WDG	132	1.033598	5	14.25	4.683747	167.18	1.22919	20
		6.6	0.995807						20
BOGTx	2WDG	132	1.040576		20.0004	-0.01043	3.7031	0.91097	50
		11	1.039331						50
BlueScopeTx	2WDG	132	1.040858	12	188.078	126.3892	948.92	28.6551	300
		33	1.057249						300
DT330Tx	2WDG	330	1.03	14	287.897	-96.2405	307.48	13.2371	1125
		132	1.049129						1125
MNTx1	2WDG	132	1.015919	15	8.34927	14.23265	132.86	1.34105	30
		33	1.044169						30
MNTx2	2WDG	132	1.01595	2	4.52112	-12.4093	86.398	0.91198	30
		33	1.04414						30
MTTx	2WDG	132	1.041536	9	53.998	17.74824	53.82	2.61412	240
		33	0.997029						240
OHTx1	2WDG	132	1.04043	3	6.62717	2.083825	4.0157	0.11982	60
		33	1.009143						60
OHTx2	2WDG	132	1.04043	3	6.35524	2.208876	0.4231	0.11612	60
		33	1.009143						60
SHTx	2WDG	132	1.031686	9	56.0133	10.77377	75.047	2.72983	180
		33	0.992261						180
SPHTx	2WDG	132	1.040858	2	70.04	-1.3E-05	166.52	7.87021	120
		33	0.994627						120
TWTx	2WDG	11	1.022536	2	395.793	-38.9224	1359.9	54.8482	400
		132	1.048706						400
ULTx1	2WDG	132	1.025665	5	6.22048	2.379472	11.756	0.25951	30
		11	1.009315						30
ULTx2	2WDG	132	1.025665	5	6.22048	2.379472	11.756	0.25951	30
		11	1.009315						30

2.4. Stability Studies to investigate the generators conformance to the NER

The stability studies conducted and reported in this section help determine:

- The capability of the 2 gas and 1 steam generators at Bamarang to operate continuously uninterrupted for 2-phase-to-ground faults, for the duration of 120ms at the Dapto 132kV Busbar (minimum access standard according to clause S5.2.5.3 of the NER).
- The critical clearing time at which the generators marginally survive.
- Both peak and light load situations were investigated. The peak load conditions are based on the load forecast at year 2014. The light load conditions are based on 40% of the peak load. The BlueScope load of 226.6MVA and the Auxiliary load of 15MVA at the Bamarang Power Station, remain constant for both the peak and light load conditions.

The steam set is a lighter set in terms of its inertial constant, hence its responses are more oscillatory than that of the gas sets. With the responses of the gas and steam sets relatively similar with regards to critical clearing time, only the responses of the steam set are shown.

The 2 gas and 1 steam sets both use an IEEE Type 1 AVR in the studies with the provided settings as shown in Table B2. The IEEE Type 1 AVR model used in the study was simplified to neglect the rectifier voltage regulation function, and this should not significantly affect the results of the studies.

The steam set, being a lighter set, became unstable first with the 2 gas sets following closely. The stability of the steam set determines the critical clearing time for the 400MW Bamarang Power Station. As a NER requirement, the generators must be equipped with loss of synchronism protection. At critical conditions, this would operate first on the steam set and possibly allow the gas turbines to remain on line.

The critical clearing time for 132kV faults at Dapto was determined by the stability of the 400MW Tallawarra Power Station. The critical clearing times for peak and light load conditions are shown in the Table below.

Table 8: Summary of faults at Dapto 132kV

	Critical Clearing Time	
	3-Phase	2-Phase-to-ground
Peak Load	270ms	450ms
Light Load	250ms	430ms

A 2-phase-to-ground fault at Dapto 132kV Busbar was applied at 0.2sec and cleared at 0.32sec to represent the minimum required fault duration of 120ms.

Bamarang CCGT Stability Studies

One of the lines between Dapto and a T-junction, where the 400MW Tallawarra Power Station was connected, was disconnected at 0.32s to represent a severe post fault condition. The responses of the steam set for a 120ms fault duration is shown in Figures 2 and 3.

Bamarang CCGT Stability Studies

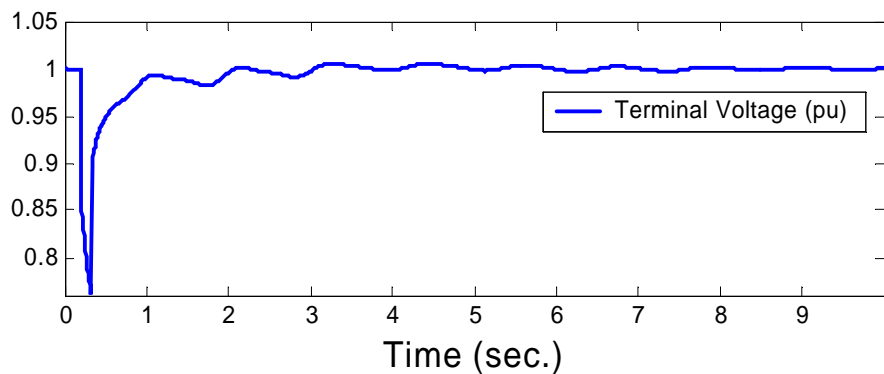
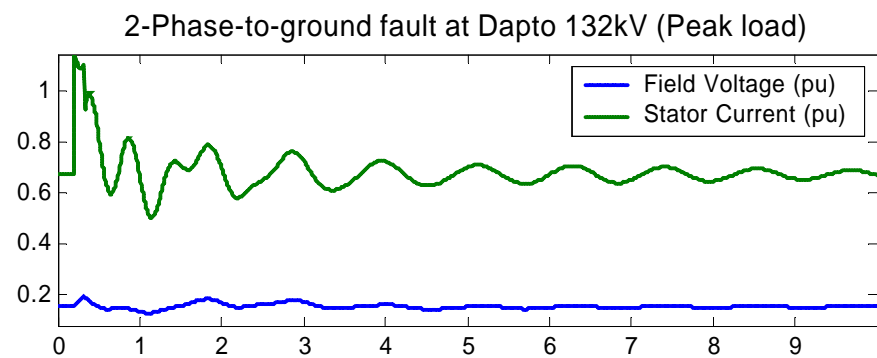
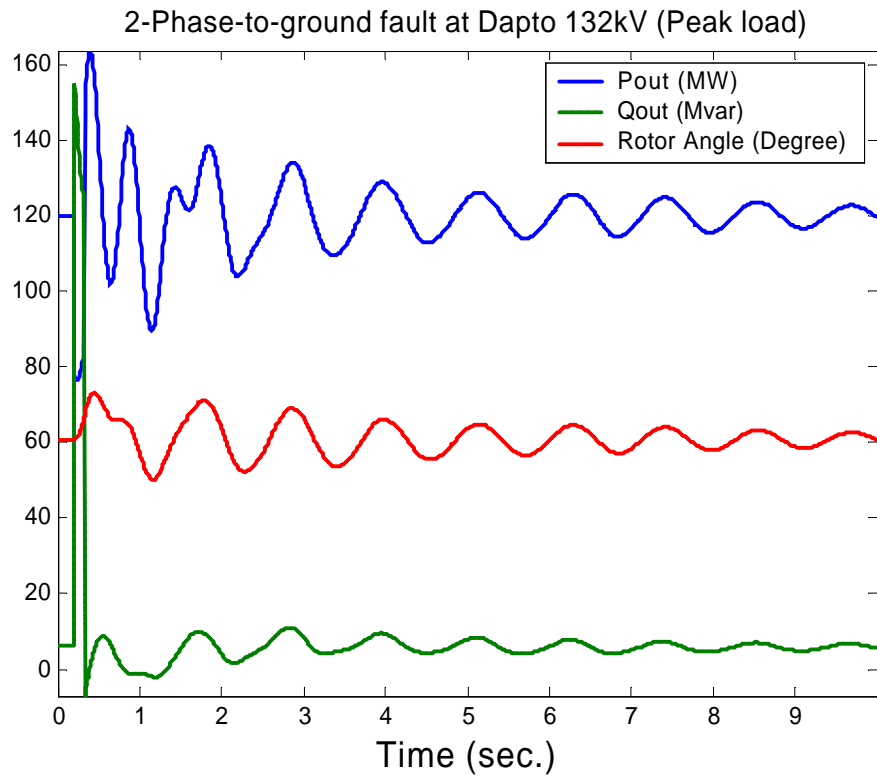

Figure 2: Response of the steam set at the 400MW Bamarang Power Station under peak load conditions, subject to a 120ms 2-phase-to-ground fault at Dapto 132kV Busbar.

Bamarang CCGT Stability Studies

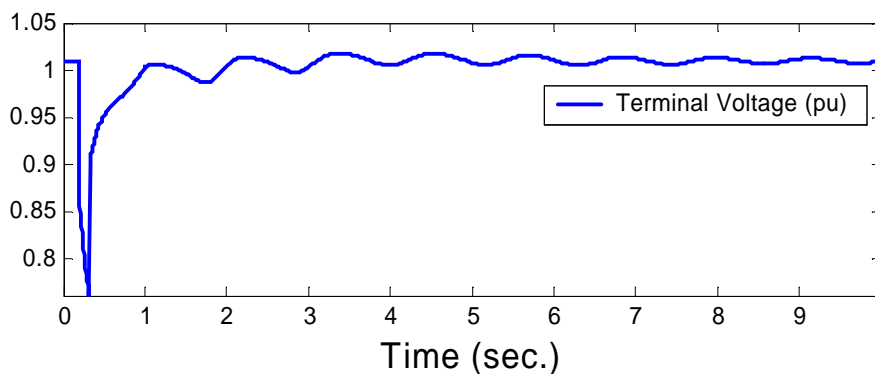
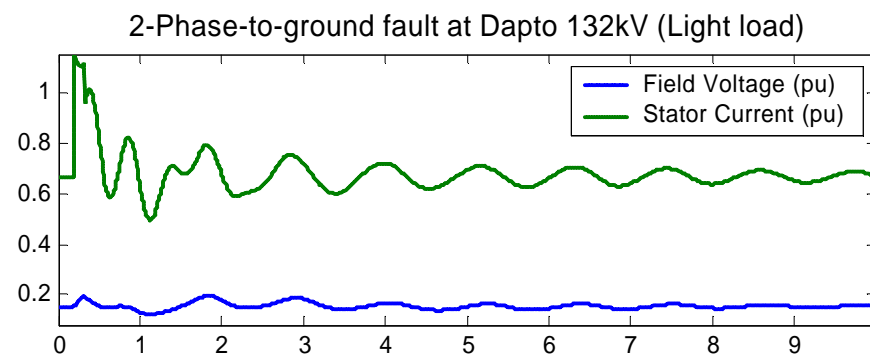
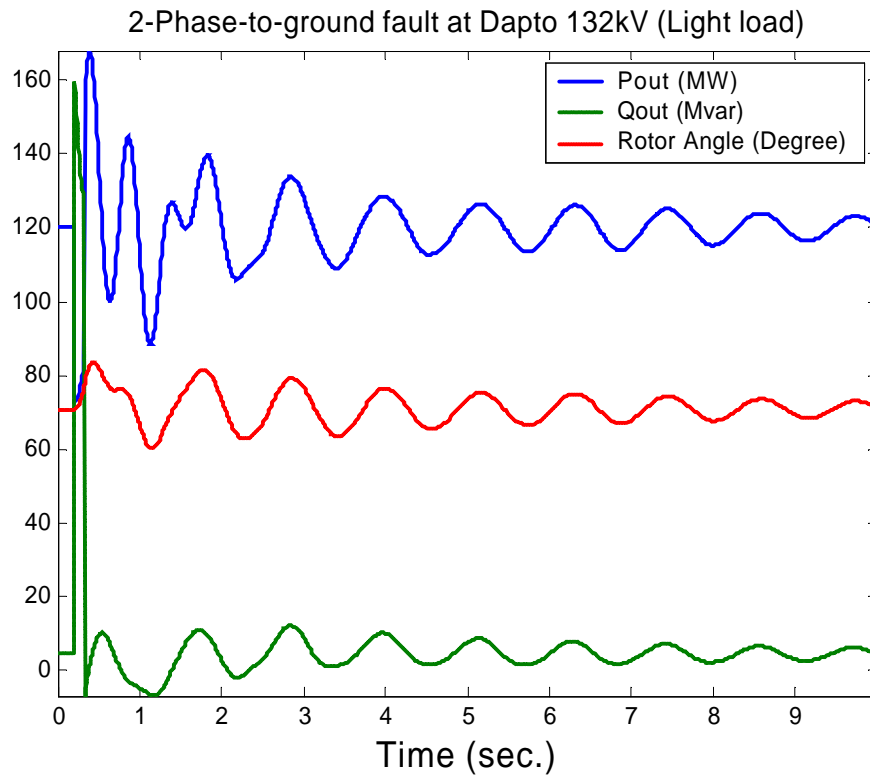

Figure 3: Response of the steam set at the 400MW Bamarang Power Station under light load conditions, subject to a 120ms 2-phase-to-ground fault at Dapto 132kV Busbar.

Bamarang CCGT Stability Studies

From the peak and light load responses, the light load condition results in larger, hence unfavourable, swing responses. For both load forecast conditions, stabilising signals are not likely to be required for all the gas and steam sets at the 400MW Bamarang Power Station. The NER requires oscillations to be damped to half its initial amplitude after 5 seconds, and the results show better damping.

2.5. Stability Studies for Faults on other parts of the network

This section investigates the critical clearing times of faults near Shoalhaven and Bamarang.

2.5.1. Fault on Shoalhaven-Mt Terry line near Shoalhaven

3-phase and 2-phase-to-ground faults at Shoalhaven 132kV Busbar, followed by clearing one of a line between Shoalhaven and Mt Terry, were investigated. The critical clearing times for peak and light load conditions are summarised in the Table below.

Table 9: Summary of faults at Shoalhaven 132kV

	Critical Clearing Time	
	3-Phase	2-Phase-to-ground
Peak Load	220ms	440ms
Light Load	190ms	370ms

During the peak load condition with the loss of a line between Shoalhaven and Mt Terry, the 400MW export from the Power Station at Bamarang will transfer 166MW through the remaining line between Shoalhaven and Mt Terry, supplying 234MW to the loads at Shoalhaven and Southern part of the system. As the remaining Shoalhaven-Mt Terry line has a continuous summer rating of 197MVA and an emergency rating of 232MVA, this is acceptable.

During the light load condition with the loss of a Shoalhaven-Mt Terry line, the Power Station's 400MW export will transfer 306.4MW through the remaining Shoalhaven-Mt Terry line, exceeding a 10 minute rating of 236.4MVA (i.e. 120% of continuous rating). In this respect, the Power Station has to runback its export to 197MVA (during summer) or 210MVA (during winter) in less than 5 minutes specified by Integral Energy, since a 5 minute rating is only 275.8MVA (i.e. 140% of continuous rating). Integral Energy's email dated 15 July 2005, advising the general 10 and 5 minute rating, is shown in Appendix D.

However, light loads usually occur during the early morning when temperature is low and sun irradiation is absent. During such times, the emergency rating

Bamarang CCGT Stability Studies

would be above 236MVA and it might not be necessary to reduce output. This would be a matter of negotiating with Integral Energy.

2.5.2. Fault on Bamarang-Shoalhaven line near Bamarang

3-phase and 2-phase-to-ground faults at Bamarang 132kV Busbar followed by clearing a line between Bamarang and Shoalhaven were investigated. The critical clearing times for peak and light load conditions are summarised in the Table below.

Table 10: Summary of faults at Bamarang 132kV

	Critical Clearing Time	
	3-Phase	2-Phase-to-ground
Peak Load	210ms	340ms
Light Load	210ms	340ms

During both peak and light load conditions, with the loss of a Bamarang-Shoalhaven line, the Power Station at Bamarang will have to runback its export to below the 200MVA rating of the remaining Bamarang-Shoalhaven line within the 10 minute time limitation specified by Integral Energy to avoid overheating of the remaining line. The 200MVA rating applies to specific conditions of full sun, high temperature, and very low wind. At other conditions, the rating would be considerably higher. This will have to be negotiated with Integral Energy on their finalised 10 minute rating. Integral Energy email dated 15 July 2005 is shown in Appendix D.

The generator are required to be provide runback facilities for the 2 gas and steam sets to reduce exports upon receipt of an appropriate signal from Integral Energy on the failure of the corresponding line.

2.6. Summary

The following table summarises the results found from the stability studies in relation to critical clearing time:

Table 11: Summary of stability study results

Fault Location	Critical Clearing time			
	2-phase-to-ground	3-phase	2-phase-to-ground	3-phase
	Peak Load		Light Load	
Dapto 132kV Busbar*	450ms	270ms	430ms	250ms
Shoalhaven-Mt Terry 132kV Line	440ms	220ms	370ms	190ms
Bamarang-Shoalhaven 132kV Line	340ms	210ms	340ms	210ms

* Critical clearing times for Tallawarra set.

3. Generator Power Output Runback

As discussed in the sections 2.5.1 and 2.5.2 above, it may be necessary to run back the output of the generators on loss of a Bamarang-Shoalhaven line or a Shoalhaven-Mt Terry line. In the extreme Integral Energy could require the output to be run back from 400 to 200MW within 5 minutes. It will be necessary to consult the manufacturers of the generators to confirm that this is possible for their machines. It is expected that it will be. In that case the procedure would need to be done automatically on the receipt of an appropriate signal from Integral Energy.

The conditions under which run back would be required for an outage of a Shoalhaven-Mt Terry line are limited. However for loss of a Bamarang-Shoalhaven line the likelihood of runback is high. The conditions for runback and by how much are a matter for negotiation with Integral Energy.

As an indication of the likelihood of runback being required, the chances of outages occurring on 132kV line is usually less than one in every 100km years of exposure. This means less than one outage every 7 years for the Bamarang-Shoalhaven lines and less than once a year for the Shoalhaven-Mt Terry lines. For the latter lines the likelihood of needing to run back after a fault is small.

4. Effect of voltage dip at critical load due to the tripping of Bamarang Power Station

Voltage dip in the system affects customer hence contingency in terms of tripping of a gas set at Bamarang is considered. Critical load at Moruya North was selected since it was at the furthest south of the system and was most susceptible to voltage variation in the system. Two scenarios of generator tripping at Bamarang were investigated: (i) full load operation of a gas set at

Bamarang CCGT Stability Studies

Bamarang followed by tripping of this gas set, and (ii) full load operation of a gas set and half load operation of the steam set followed by tripping.

For both of the above cases it was assumed that there were no other generators on-line at Bamarang.

The voltage drops were calculated by running load flows with the generators connected then fixing the transformer taps and running a second load flow with the generators disconnected. Loads were assumed to be constant power. This gives pessimistic results as some loads will be constant impedance which give smaller dips.

Loss of all three generators simultaneously was not considered as this would be a triple contingency event and not considered credible in terms of the NER. Loss of a generator with others still on-line will only cause a momentary dip of 1 or 2% which is corrected in 1 or 2 seconds by AVR action. Such disturbances are not considered significant.

4.1. Loss of a Single Gas Turbine

A single gas set running at full load and then tripping is considered a possibility at the initial stage of operating the Power Station. The voltage dips at the Moruya North load for peak and light load conditions are tabulated in the following Table.

Table 12: Summary of voltage dip at 33kV Moruya North bus (Single Gas Set)

	Voltage at Moruya North 33kV bus	
	1 gas set at Bamarang operating at full load	Tripping off the gas set at Bamarang
Peak Load	1.05pu	0.992pu
Light Load	1.04pu	1.03pu

From the above Table, the voltage dip at Moruya North due to the tripping of the only operating gas set at Bamarang is 5.5%.

4.2. Loss of a Single Gas Turbine plus the Steam Set

The operation of a single gas turbine with the steam turbine on half load would represent a normal mode of operation for the Power Station when one gas turbine is down for maintenance. Loss of the on line gas turbine would also require tripping of the steam set. Studies to determine the dip for such an event were carried out for peak and light loads, with the results given in the Table below.

Table 13: Summary of voltage dip at 33kV Moruya North bus (Single Gas & Steam Set)

	Voltage at Moruya North 33kV bus	
	1 gas set and 1 steam set at Bamarang operating at full load and half load respectively	Tripping of the gas set and steam set at Bamarang
Peak Load	1.05pu	0.983pu
Light Load	1.04pu	1.03pu

From the above Table, the voltage dip at Moruya North due to the tripping of the only operating gas set at Bamarang is 6.3%.

5. Conclusion

The stability studies have shown that the two gas and one steam sets at the 400MW Bamarang Power Station satisfy NEMMCO's minimum requirement to remain online following a 120ms 2-phase-to-ground fault at the Dapto 132kV bus, followed with one of the lines between Dapto and the T-junction to Tallawarra cleared.

The oscillations were found adequately damped, and stabilising signals are not likely to be required. The NER requires oscillations to be damped to half its initial amplitude after 5 seconds, and the results show damping better than this.

As the steam set is lighter than the gas set, its responses would be faster than the gas sets. This resulted in the steam set being unstable before the 2 gas sets. Out-of-step protection may prevent all sets being tripped by tripping the steam set first. However, as critical clearing times are well in excess of normal clearing time, it is unlikely that any out-of-step operation will occur.

The 400MW Tallawarra Power Station has a lower critical clearing time than that of the 400MW Bamarang Power Station. This determines the critical clearing times for faults on the Dapto 132kV bus.

During peak load condition for fault at Shoalhaven followed with the clearing of a Shoalhaven-Mt Terry line, the Power Station need not reduce its export. The Power Station will be capable of exporting 400MW, transferring 166MW to the north area and 234MW to south area and Shoalhaven. During a light load condition, evaluated based on 40% of peak load, negotiation with Integral Energy on the maximum allowable time for runback of export is required. In our opinion, there may not be a problem in negotiating a longer than 10 minute runback time or no runback, particularly if the assumption of light load condition occurring during early hours of the day is considered.

During both the peak and light load conditions for faults at Bamarang followed with the loss of a Bamarang-Shoalhaven line, the Power Station at Bamarang will have to runback its export to below the 200MVA rating of the remaining Bamarang-Shoalhaven line within the 10 minute time limitation specified by Integral Energy to avoid overheating of the remaining line. Considering the unlikely occurrence of fault at the short 7km Bamarang-Shoalhaven line, based on a 1 fault per 100km per year consideration, it may be possible to negotiate with Integral Energy a longer than 10 minute of runback time.

Voltage dip in the system owing to contingency at the Power Station affects the customer's voltage. The tripping of a gas set or a gas set with a steam set at the Power Station is investigated. It was found from the study that there was no serious voltage dip in the system during the peak load condition.

Bamarang CCGT Stability Studies

Appendix

Appendix A – Network Data

Appendix B – Generator Data

Appendix C – AVR Block Diagram

**Appendix D – Integral Energy Email Dated 15th July
2005**

Appendix A: Network Data

Table A 1: Generators and Motors

Location	Type	Rating (MVA)	Generator Actual Rating (MW)	Generator Max Rating (MVAr)	Generator Min Rating (MVAr)	Load (MVA)	Load power factor	Shunt power (kVA)	Shunt type	Shunt power factor
BMlocal	Load	0.1				15	0.95			
G1_BM	Generator	178	140	100	-100					
G2_BM	Generator	178	140	100	-100					
G3_BM	Generator	178	120	100	-100					
BBlocal	Load	50				27.5	0.984			
BLBlocal	Load	0.1				91	0.997			
BOGlocal	Load	50				50	1			
BPlocal	Load	50				3.5	0.8			
BlueScope	Load	240				226.6	0.83			
MNlocal	Load	100				32.5	0.99			
OHlocal	Load	0.1				34.2	0.949			
SPHlocal	Load	0.1				175.1	1			
ULlocal	Load	50				33.3	0.934			
DTcap1	Shunt Cap	80						80000	CAP	0
DTcap2	Shunt Cap	80						80000	CAP	0
SPHcap	Shunt Cap	80						80000	CAP	0
G_DT330	Generator	10000	10000	10000	-10000					
G_TW	Generator	500	400	100	-100					
MTlocal	Load	150				142.1	0.95			
SHlocal	Load	160				142.6	0.982			

Bamarang CCGT Stability Studies

Table A 2: Transformers

Location	Type	Winding	Winding type	Winding voltage (kV)	Winding tap type	Number of tap steps	Tap position	Tap min voltage (%)	Tap max voltage (%)	Rating (MVA)	(%100MVA)			
											R1	X1	R0	X0
BBTx1	2WDG	P	Star	132	Controlled	22	17	-22.5	5	23	0	0	0	0
		S	ZigZag	11						23	2.7	59.3	2.7	59.3
BBTx2	2WDG	P	Star	132	Controlled	22	17	-22.5	5	23	0	0	0	0
		S	ZigZag	11						23	2.7	59.6	2.7	59.6
BLBTx1	2WDG	P	Star	132	Controlled	16	5	-15	5	60	0.44	30	0.44	30
		S	Star	33						60	0.4	-4.29	0.4	-4.29
		T									1	67.3	1	67.3
BLBTx2	2WDG	P	Star	132	Controlled	16	5	-15	5	60	0.47	29.1	0.47	29.1
		S	Star	33						60	0.4	-3.34	0.4	-3.34
		T									1	66.9	1	66.9
BMTx1	2WDG	P	Star	132	Fixed	20	12	-10	10	162	0.12	7.15	0.12	7.15
		S	Delta	14.5						162	0	0	0	0
BMTx2	2WDG	P	Star	132	Fixed	20	12	-10	10	162	0.12	7.15	0.12	7.15
		S	Delta	14.5						162	0	0	0	0
BMTx3	2WDG	P	Star	132	Fixed	20	12	-10	10	162	0.12	7.15	0.12	7.15
		S	Delta	14.5						162	0	0	0	0
BMTxaux	2WDG	P	Star	132	Controlled	10	10	-5	5	20	2.12	47.1	2.12	47.1
		S	Star	6.6						20	0	0	0	0
BOGTx	2WDG	P	Delta	132						50	0.1	0	0.1	0
		S	Star	11						50	0	24.6	0	24.6
BlueScopeTx	2WDG	P	Star	132	Fixed	16	12	-15	5	300	0.172	5.194	0.172	5.194
		S	Star	33						300	0	0	0	0
		T									0.68	10.6	0.68	10.6
DT330Tx	2WDG	P	Star	330	Controlled	20	21	-10	10	1125	0.0354	1.524	0.0354	1.524
		S	Star	132						1125	0	0	0	0

Bamarang CCGT Stability Studies

Table A 2 (Cont'd): Transformers

Location	Type	Winding	Winding type	Winding voltage (kV)	Winding tap type	Number of tap steps	Tap position	Tap min voltage (%)	Tap max voltage (%)	Rating (MVA)	(%100MVA)			
											R1	X1	R0	X0
MNTx1	2WDG	P	Star	132	Controlled	24	25	-18.9393	3.7878	30	0	0	0	0
		S	Star	33						30	5.32	53.7	5.32	53.7
MNTx2	2WDG	P	Star	132	Controlled	20	11	-20	5	30	0	0	0	0
		S	Star	33						30	5.4	57	5.4	57
MTTx	2WDG	P	Star	132	Controlled	16	12	-8.4	14	240	0.175	8.5	0.175	8.5
		S	Star	33						240	0	0	0	0
OHTx1	2WDG	P	Star	132	Controlled	16	5	-15	5	60	0.47	29.4	0.47	29.4
		S	Star	33						60	0.4	-2.7	0.4	-2.7
		T									1	67.6	1	67.6
OHTx2	2WDG	P	Star	132	Controlled	16	5	-15	5	60	0.1	-4.6	0.1	-3.2
		S	Star	33						60	0	30.5	0	28.7
		T									0.1	68.4	0.1	56.9
SHTx	2WDG	P	Star	132	Controlled	16	14	-8.4	14	180	0.24	8.73	0.24	8.73
		S	Star	33						180	0	0	2.9	88
SPHTx	2WDG	P	Star	132	Controlled	16	6	-15	5	120	0.2	15.9	0.2	15.9
		S	Star	33						120	0.15	1.1	0.15	1.1
		T									0.3	47.1	0.3	47.1
TWTx	2WDG	P	Delta	11						400	0.09	3.63	0.09	3.63
		S	Star	132	Fixed	7	3	-12.5	5	400	0	0	0	0
ULTx1	2WDG	P	Star	132	Controlled	22	14	-22.5	5	30	0	0	0	0
		S	ZigZag	11						30	2.7	59.6	2.7	59.6
ULTx2	2WDG	P	Star	132	Controlled	22	14	-22.5	5	30	0	0	0	0
		S	ZigZag	11						30	2.7	59.6	2.7	59.6

Bamarang CCGT Stability Studies

Table A 3: Control Transformers

Location	Controlling voltage (%)	Line drop compensation res (%100MVA)	Line drop compensation reac (%100MVA)
BBTx1	105	0	0
BBTx2	105	0	0
BLBTx1	101.5	0	0
BLBTx2	101.5	0	0
BMTxaux	100	0	0
DT330Tx	105.68	0	0
MNTx1	105	0	0
MNTx2	105	0	0
MTTx	100	0	0
OHTx1	101.514999	0	0
OHTx2	101.514999	0	0
SHTx	100	0	0
SPHTx	100	0	0
ULTx1	99.090897	31.299999	0
ULTx2	99.090897	31.299999	0

Bamarang CCGT Stability Studies

Table A 4: Transmission Network

Sending end location	Receiving end location	Length (m)	R1	X1	Pos sequence charging	R0	X0	Zero sequence charging	Voltage (kV)
G_DT330	DT330Tx	0.7863	0	0	0	0	0	0	330
BB	EL	53700	11.4	14.4	2.51	21.1	38.2	1.89	132
BBTx1	BB	1	0.01	0.01	0	0.01	0.01	0	132
BBTx2	BB	1	0.01	0.01	0	0.01	0.01	0	132
BLB	DT	28400	1.0577	4.9385	1.143248	4.1375	14.621	0.698392	132
BLB	DT	28400	1.0433	4.8712	1.127656	4.081	14.422	0.688867	132
BLBTx1	BLB	1	0.01	0.01	0.01	0.01	0.01	0.01	132
BLBTx2	BLB	1	0.01	0.01	0.01	0.01	0.01	0.01	132
BM	SH	7000	0.2863	1.4602	2.1525	1.1599	4.0467	0.6244	132
BM	SH	7000	0.2863	1.4602	2.1525	1.1599	4.0467	0.6244	132
BMTx1	BM	1	0	0	0	0	0	0	132
BMTx2	BM	1	0	0	0	0	0	0	132
BMTx3	BM	1	0	0	0	0	0	0	132
BMTxaux	BM	1	0	0	0	0	0	0	132
BOG	SPH	2500	0.25	0.62	0.17	0.75	1.75	0	132
BOG	BOGTx	1	0.01	0.01	0.01	0.01	0.01	0.01	132
BP	BPlocal	2210	0.187	0.518	0.109	0.588	1.55	0.081	132
BP	DT	32500	2.67	7.73	1.58	7.66	20.1	1.16	132
BlueScopeTx	SPH	1	0	0	0	0	0	0	132
DT	DTcap1	1	0.01	0.01	0.01	0.01	0.01	0.01	132
DT	DTcap2	1	0.01	0.01	0.01	0.01	0.01	0.01	132
DT330Tx	DT	1	0	0	0	0	0	0	132
EL	SH	54566	2.7193	12.301	2.82949	10.087	31.933	1.993505	132
MN	EL	72600	3.584	16.367	3.7643	16.618	48.862	2.6542	132
MN	MNTx2	1	0.01	0.01	0	0.01	0.01	0	132
MN	BB	21.1	4.32	5.61	1	8.15	14.8	0.737	132
MN	MNTx1	1	0.01	0.01	0	0.01	0.01	0	132
MT	SH	46300	2.27	10.5	2.39	9.96	30.4	1.71	132
MT	DT	8600	0.311	1.88	0.456	0.994	3.47	0.329	132
MT	DT	8790	0.318	1.92	0.466	1.02	3.57	0.335	132
MT	MTTx	312.57	0	0	0	0	0	0	132
SH	MT	46100	2.27	10.4	2.38	9.94	30.3	1.71	132
SH	EL	59397	2.958	13.39	3.079	10.98	34.76	2.169	132
SHTx	SH	222.04	0	0	0	0	0	0	132
SPH	DT	13200	0.463	2.83	0.71	2.47	9.41	0.425	132
SPH	DT	13200	0.463	2.83	0.71	2.47	9.41	0.425	132
SPH	SW 0712 2942	4240	0.251	1	0.208	0.724	2.38	0.128	132
SPH	TWtee1	10000	0.2817	1.7169	0.431043	1.5839	5.2898	0.25391	132
SPH	SPHcap	1	0.01	0.01	0.01	0.01	0.01	0.01	132
SPH	TWtee2	9117.6	0.2803	1.7129	0.428518	1.541	5.1742	0.25308	132
SPHTx	SPH	1	0	0	0	0	0	0	132

Bamarang CCGT Stability Studies

Table A 4 (Cont'd): Transmission Network

Sending end location	Receiving end location	Length (m)	R1	X1	Pos sequence charging	R0	X0	Zero sequence charging	Voltage (kV)
SW 0696 2968	SPH	1110	0.0664	0.267	0.054	0.214	0.516	0.04	132
SW 0696 2968	SW 0712 2942	3650	0.216	0.862	0.179	0.622	2.05	0.111	132
SW 0712 2942	OHTx2	1	0.01	0.01	0.01	0.01	0.011	0.01	132
SW 0712 2942	OHTx1	1	0.01	0.01	0.01	0.01	0.01	0.01	132
TWtee1	DT	3400	0.1843	1.1231	0.281957	1.0361	3.4602	0.166089	132
TWtee1	TWtee2	14.142	0	1E-05	0	0	0	0	132
TWtee2	DT	3400	0.1927	1.1771	0.294482	1.059	3.5558	0.17392	132
TWtee2	TWTx	3400	0.1391	0.7092	1.0455	0.5634	1.9655	0.30328	132
UL	EL	6860	0.205	1.43	0.38	1.01	3.96	0.207	132
ULTx1	UL	1	0.01	0.01	0	0.01	0.01	0	132
ULTx2	UL	1	0.01	0.01	0	0.01	0.01	0	132
xx	UL	6630	0.199	1.38	0.367	0.98	3.83	0.2	132
xx	EL	900	0.0368	0.1877	0.27675	0.1491	0.5203	0.08028	132
BLBlocal	BLBTx2	1	0.01	0.01	0.01	0.01	0.01	0.01	33
BLBlocal	BLBTx1	1	0.01	0.01	0.01	0.01	0.01	0.01	33
BlueScope	BlueScopeTx	1	0	0	0	0	0	0	33
MNTx1	MNlocal	1	0.01	0.01	0	0.01	0.01	0	33
MNTx2	MNlocal	1	0.01	0.01	0.01	0.01	0.01	0.01	33
MTTx	MTlocal	212.13	0	0	0	0	0	0	33
OHTx1	OHlocal	1	0.01	0.01	0.01	0.01	0.01	0.01	33
OHTx2	OHlocal	1	0.01	0.01	0.01	0.01	0.01	0.01	33
SHlocal	SHTx	1	0	0	0	0	0	0	33
SPHlocal	SPHTx	1	0	0	0	0	0	0	33
G1_BM	BMTx1	1	0	0	0	0	0	0	14.5
G2_BM	BMTx2	1	0	0	0	0	0	0	14.5
G3_BM	BMTx3	1	0	0	0	0	0	0	14.5
BBlocal	BBTx1	1	0.01	0.01	0	0.01	0.01	0	11
BBlocal	BBTx2	1	0.01	0.01	0	0.01	0.01	0	11
BOGTx	BOGlocal	1	0.01	0.01	0.01	0.01	0.01	0.01	11
TWTx	G_TW	10	0.1884	0.09	0.000084	0.3311	0.0599	0.000084	11
ULlocal	ULTx2	1	0.01	0.01	0	0.01	0.01	0	11
ULlocal	ULTx1	1	0.01	0.01	0	0.01	0.01	0	11
BMlocal	BMTxaux	1	0	0	0	0	0	0	6.6

Bamarang CCGT Stability Studies

Table A 5: Source Impedance (%100MVABase)

Dapto 330kV			
	Positive Sequence	Negative Sequence	Zero Sequence
Pre-fault condition	0.08+j0.975	0.08+j0.976	0.218+j1.2

Appendix B: Generator Data

Table B 1: Generator Dynamic Data

Location	Active power (MW)	Voltage (%)	Synchronous Reactance (%100MVA)		Transient Reactance (%100MVA)		Subtransient Reactance (%100MVA)		Generator Zero Sequence Reactance (%100MVA)
			Xd	Xq	Xd'	Xq'	Xd''	Xq''	
G1_BM	140	100	117.419998	114.599998	10.9	19.42	8.2	8.03	4.27
G2_BM	140	100	117.419998	114.599998	10.9	19.42	8.2	8.03	4.27
G3_BM	120	100	117.419998	114.599998	10.9	19.42	8.2	8.03	4.27
G_DT330	10000	103	0.975	0.975	0.975	0.975	0.975	0.975	1..2
G_TW	400	104	40	38	5	3.75	3.75	3.75	2.55

Table B 1 (Cont'd): Generator Dynamic Data

Location	Stator Resistance (%100MVA)			Tdo'	Tdo''	Tqo'	Tqo''	Inertia Constant	Portier Reactance (%100MVA)	Saturation Factor (%100MVA)	
	R1	R2	R0							Current @	
				seconds						100%Vt	120%Vt
G1_BM	0.05	0.05	0.05	11	0.05	1.2	0.09	6.1	10.11	1.2	1.6
G2_BM	0.05	0.05	0.05	11	0.05	1.2	0.09	6.1	10.11	1.2	1.6
G3_BM	0.05	0.05	0.05	11	0.05	1.2	0.09	6.1	10.11	1.2	1.6
G_DT330	0.08	0.08	0.218	1.5	0.8	1.3	0.6	10000	35.6	1.2	1.6
G_TW	0.066	0.066	0.066	5.55	0.039	1	0.04	6	6.44	1.2	1.6

Bamarang CCGT Stability Studies

Table B 2: AVR Dynamic Data (Applicable for the Bamarang Generators)

Filter	Gain	Amplifier					Feedback Loop			Exciter				
TR	KA	TA	TC	Vp+	Vp-	Max. Rate of change	KF	TF1	TF2	Te	E _{max}	E _{min}	Feedback at 0.75E _{max}	Feedback at 1.0E _{max}
sec	pu	sec	sec	pu	pu	pu/sec	pu	sec	sec	sec	pu	pu	pu	pu
0.02	115.927	0.11	0.475	10.65	-5	1000	0	1	0	0.79	5	0	0.0024	0.028

Appendix C: AVR Block Diagram

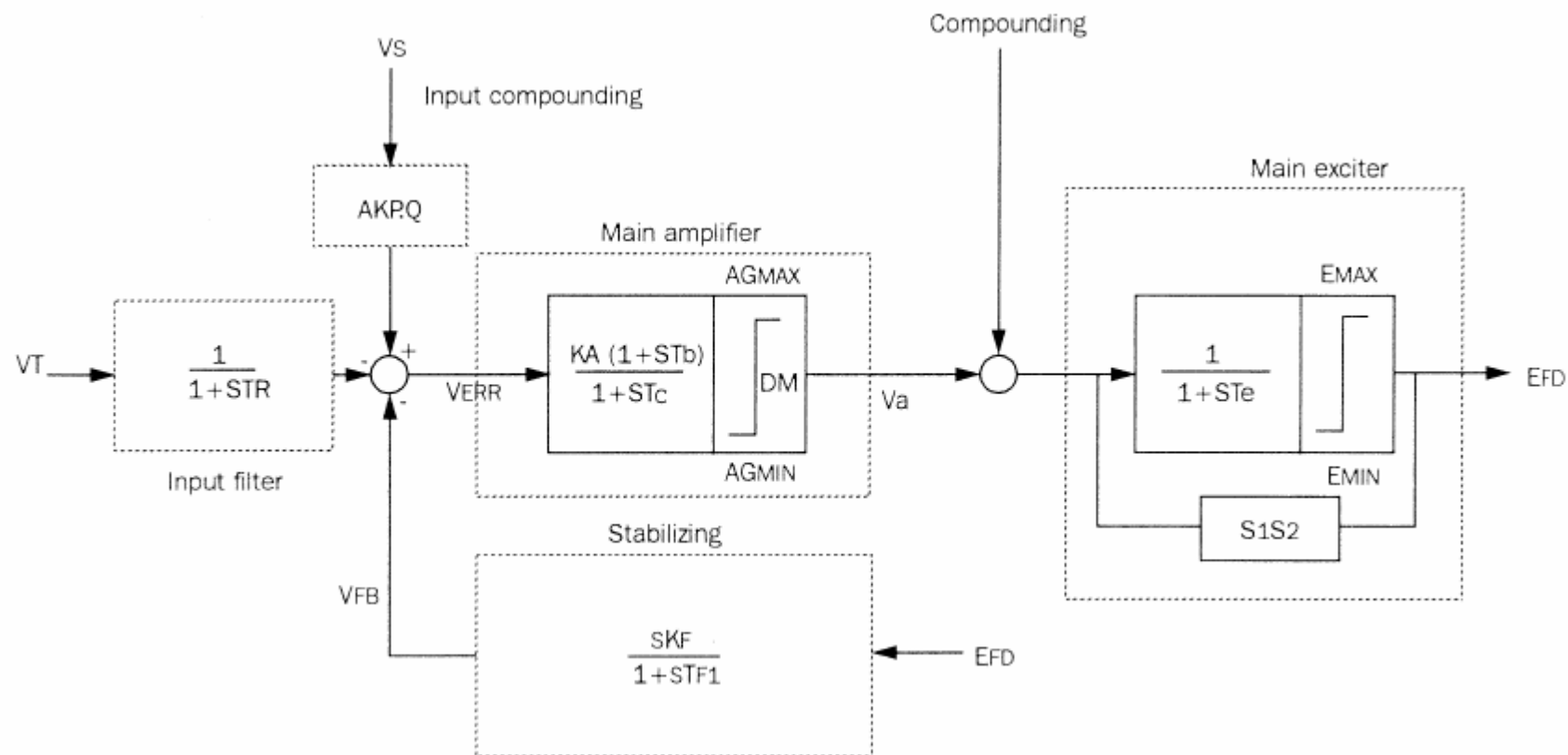

Figure 4: Block Diagram IEEE Type 1 AVR

Bamarang CCGT Stability Studies

Appendix D: Email from Integral Energy

From: Gary Posadas [<mailto:Gary.Posadas@integral.com.au>]
Sent: Friday, 15 July 2005 10:43 AM
To: chan@hmac.com.au
Cc: Andrew Hardy; Ty Christopher
Subject: Bamarang Generation

Chan,

Following our conversation yesterday with respect to the "Rapid Runback Scheme" I have sought some rating detail from our Transmission Mains design group. However as I indicated to you, our standard "concrete pole with standoff insulator design" for 132kV medium capacity feeders has a continuous rating of 172/288MVA summer/winter. This design will not be adequate for the Bamarang needs being 2 x 200MVA continuous, such that a special design will be required.

Our mains design group will therefore need to do a preliminary design to derive at an appropriate construction to achieve the above continuous rating and then allocate an appropriate 10 minute rating based on the selected design. From your perspective however, for the time being you can go ahead and work on a 10 minute window in which the scheme must reduce load to the equivalent of the 200MVA rating for the remaining Bamarang to Shoalhaven feeder.

As we also discussed for a failure of one of the Shoalhaven to Mt Terry feeders the "Rapid Runback Scheme" must again reduce the generation output within the same 10 minute window. But in this case the load reduction will not be as severe. Generation output can be reduced to the continuous rating of the remaining Shoalhaven to Mt Terry feeder (197MVA), plus the local Shoalhaven and southern load, being between 68MVA to 181MVA, as indicated in the draft report we issued.

In either case if the 10 minute rating is insufficient to cater the prevailing load, perhaps the "Rapid Runback Scheme" will need to work within a much tighter time window, possible less than 1 minute. Note, that these short time ratings may not only be limited by conductor sags but possibly also by protection schemes. Typically accepted transmission short time thermal limits suggest that a 10min rating will only provide 120% of continuous rating, whilst a 5min rating will only provide 140% of continuous rating.

The time window we seek represents a requirement for 200% of continuous rating for an outage of either of the Bamarang to Shoalhaven feeders. For an outage of either of the Mt Terry to Shoalhaven feeders the time window we seek represents a requirement for 111% to 168% of continuous rating based on prevailing loads of 181MVA down to 68MVA.

Bamarang CCGT Stability Studies

Based on the above, I believe we need to determine not a 10 minute rating for these feeder, but rather a 1 minute rating and the "Rapid Runback Scheme" will need to operate within 1 minute or less. I will initiate further inquiries in the areas of short time ratings and associated protection issues.

Regards,

Gary Posadas
Senior Transmission Planner
System Development Branch
02 9853 6582
Fax 02 9853 6099
Gary.Posadas@integral.com.au