



PEDESTRIAN WIND ENVIRONMENT STATEMENT

461 CHAPEL ROAD, BANKSTOWN

WJ433-03F02(REV3)- WS REPORT

FEBRUARY 12, 2026

Prepared for:

Sustainable Development Group Limited ABN: 95 633 593 101

Level 4, 223 Castlereagh Street, Sydney, NSW



WINDTECH CONSULTANTS

www.windtechconsult.com

reception@windtechglobal.com

Sydney | Singapore | London | Melbourne | Mumbai | New York | Hong Kong | Dubai | Miami | Toronto

DOCUMENT CONTROL

Date	Revision History	Issued Revision	Prepared By (initials)	Instructed By (initials)	Reviewed & Authorised by (initials)
September 29, 2025	Initial.	0	TH/CT	SR	TH
February 11, 2025	Updated.	1	TH/CT	SR	TH
February 12, 2025	Updated.	2	TH/CT	SR	TH

The work presented in this document was carried out in accordance with the Windtech Consultants Quality Assurance System, which is based on International Standard ISO 9001.

This document is issued subject to review and authorisation by the Team Leader noted by the initials printed in the last column above. If no initials appear, this document shall be considered as preliminary or draft only and no reliance shall be placed upon it other than for information to be verified later.

This document is prepared for our Client's particular requirements which are based on a specific brief with limitations as agreed to with the Client. It is not intended for and should not be relied upon by a third party and no responsibility is undertaken to any third party without prior consent provided by Windtech Consultants. The information herein should not be reproduced, presented or reviewed except in full. Prior to passing on to a third party, the Client is to fully inform the third party of the specific brief and limitations associated with the commission.

EXECUTIVE SUMMARY

This report presents an opinion on the likely impact of the subject development located at 461 Chapel Road, Bankstown, on the local wind environment at the critical outdoor areas within and around the subject site. The effect of wind activity has been examined for the three predominant wind directions for the region, namely the south-easterly, westerly, and north-easterly winds. The analysis of the wind effects relating to the proposed development have been carried out in the context of the local wind climate, building morphology and land topography.

The conclusions of this report are drawn from our extensive experience in this field and are based on an examination of the latest architectural drawings. No wind tunnel testing has been undertaken for the subject development, and hence this report addresses only the general wind effects and any localised effects that are identifiable by visual inspection of the architectural drawings provided (received 29th January, 2026). Any recommendations in this report are made only in-principle and are based on our extensive experience in the study of wind environment effects.

The results of this assessment indicate that the development has incorporated several design features and wind mitigating strategies and is expected to be suitable for the intended use for the majority of the outdoor trafficable areas. However, there are some areas that are likely to be exposed to stronger winds. It is expected that the wind effects identified in the report can be ameliorated with the consideration of the following treatment strategies into the design of the development:

Ground Level Trafficable areas and Pedestrian Thoroughfares:

- Retention of the proposed impermeable awning along the Chapel Road and French Avenue frontages of the site as indicated in the architectural drawings.
- The inclusion of the proposed densely foliating vegetation within the proposed raised planter zones as indicated in the landscape drawings.
- The inclusion of the proposed and existing densely foliating street trees along the Chapel Road and French Avenue frontages of the site as indicated in the architectural drawings.

Level 01 Early Learning Centre Outdoor Area

- Retention of the proposed 1.8m impermeable screens along the exposed perimeter edge of the outdoor area as indicated in the architectural drawings.
- The inclusion of the proposed densely foliating vegetation within the planter zones as indicated in the landscape drawings.
- Consider the inclusion of additional wind mitigation elements such as screens or densely foliating vegetation around the corners of the building and areas intended for short duration stationary activities such as outdoor seating and play areas.

- Areas intended for short duration stationary activities such as outdoor seating are recommended to be restricted/situated away from the corners of buildings as these areas highly susceptibility to adverse wind conditions such as accelerating flows around the building.

Level 18 Communal Open Space

- Retention of the proposed 1.8m impermeable screens along the exposed perimeter edges of the communal open space as indicated in the architectural drawings.
- The inclusion of the proposed densely foliating vegetation within the planter zones as indicated in the landscape drawings.
- Areas intended for short duration stationary activities such as outdoor seating are recommended to be restricted/situated away from the corners of buildings as these areas highly susceptibility to adverse wind conditions such as accelerating flows around the building.
- Elevated Private Balconies:
 - Retention of the proposed impermeable balustrades, full-height intertenancy blade walls and end screens as indicated in the architectural drawings.

With the inclusion of the abovementioned recommendations in the final design, it is expected that wind conditions for the various trafficable outdoor areas within and around the development will be suitable for their intended uses, and that the wind speeds will satisfy the applicable criteria for pedestrian comfort and safety.

CONTENTS

1	Introduction	1
2	Description of Development and Surroundings	2
3	Regional Wind	4
4	Wind Effects on People	5
5	Results and Discussion	6
5.1	Ground Level Trafficable areas and Pedestrian Thoroughfares	7
5.2	Elevated Communal and Shared Outdoor Spaces	9
5.3	Elevated Private Balconies	13
6	References	14

Appendix A Wind Effects Glossary

INTRODUCTION

An opinion on the likely impact of the proposed design on the local wind environment affecting pedestrians within the critical outdoor areas within and around the subject development is presented in this report. The analysis of wind effects relating to the proposed development has been carried out in the context of the predominant wind directions for the region, building morphology of the development and nearby buildings, and local land topography. The conclusions of this report are drawn from our extensive experience in the field of wind engineering and studies of wind environment effects.

No wind tunnel testing has been undertaken for this assessment. Hence this report addresses only the general wind effects and any localised effects that are identifiable by visual inspection, and any recommendations in this report are made only in-principle.

DESCRIPTION OF DEVELOPMENT AND SURROUNDINGS

The site is located at 461 Chapel Road, Bankstown, and is bounded by French Avenue to the north, Chapel Road to the west, and low-rise commercial buildings to south and east. The buildings surrounding the subject development are predominately low-rise residential and commercial buildings, with a few mid-rise and high-rise apartment buildings to the south and east of the development. The further removed surrounds are predominately low-rise residential and commercial buildings.

A survey of the land topography indicates a significant slope towards the north-west immediately surrounding the site.

An aerial image of the subject site and the local surroundings is shown in Figure 1, with the frequency and magnitude of the prevailing winds is superimposed for each wind direction.

The existing site consists of a low-rise church and its associated facilities. The proposed development is 20 storeys high.

The critical outdoor trafficable areas associated with the proposed development, which are the focus of this assessment with regards to wind effects, are listed as follows:

- Ground Level Trafficable areas and Pedestrian Thoroughfares.
- Elevated Communal and Shared Outdoor Spaces.
- Elevated Private Balconies.

Legend

- Line thickness represents the magnitude of the regional wind from that direction
- Line length represents the frequency that the regional wind occurs for that direction

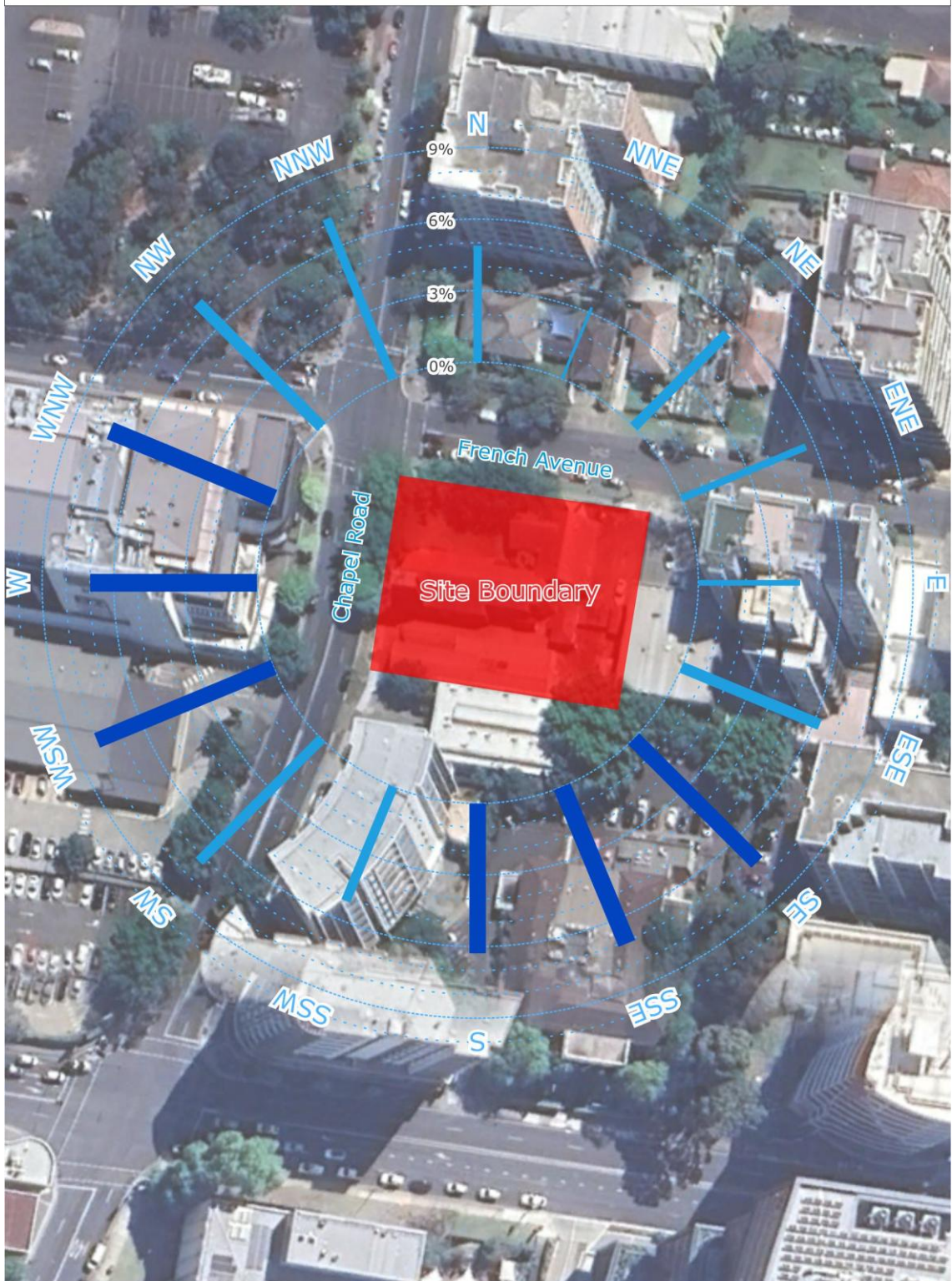

Figure 1: Aerial Image of the Site Location and Prevailing Wind Directions

3 REGIONAL WIND

The Bankstown region is governed by three principal wind directions that can potentially affect the subject development. These winds prevail from the south-east, north-east, and west. These wind directions were determined from an analysis undertaken by Windtech Consultants of recorded directional wind speeds obtained from the meteorological station located at Bankstown Airport by the Bureau of Meteorology (recorded from 1993 to 2016). The data has been corrected to represent winds over standard open terrain at a height of 10m above ground level. The results of this analysis are presented in Figure 2 in the form of a directional plot of the annual and 5% exceedance mean winds for the region. The frequency of occurrence of these winds is also shown in Figure 2.

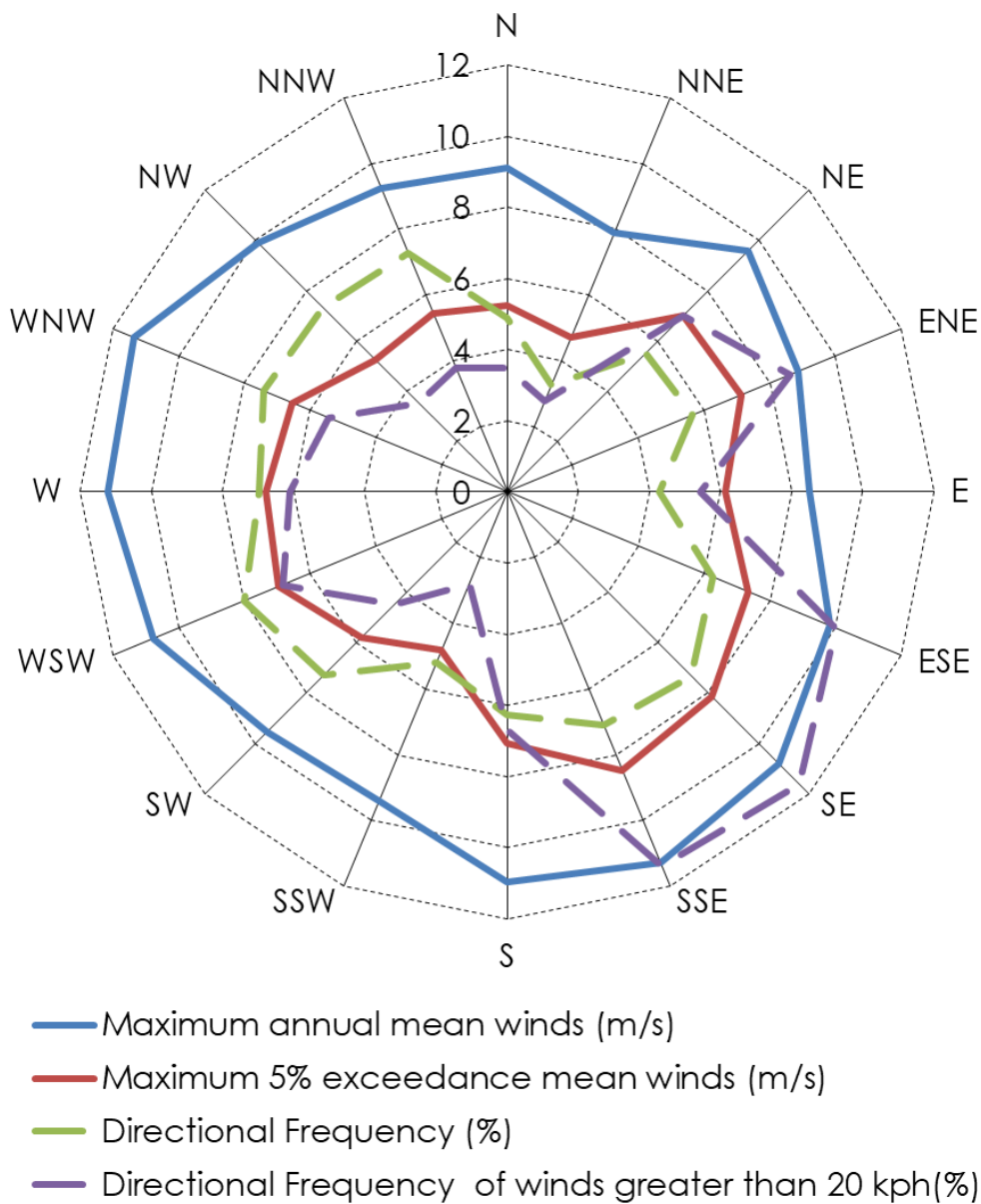

Figure 2: Directional Annual and 5% Exceedance Hourly Mean Wind Speeds (referenced to 10m height in standard open terrain), and Frequencies of Occurrence, for the Bankstown Region

4 WIND EFFECTS ON PEOPLE

The acceptability of wind in any area is dependent upon its use. For example, people walking, or window-shopping will tolerate higher wind speeds than those seated at an outdoor restaurant. Various other researchers, such as A.G. Davenport, T.V. Lawson, W.H. Melbourne, and A.D. Penwarden, have published criteria for pedestrian comfort for pedestrians in outdoor spaces for various types of activities. Some Councils and Local Government Authorities have adopted elements of some of these into their planning control requirements.

For example, A.D. Penwarden (1973) developed a modified version of the Beaufort scale which describes the effects of various wind intensities on people. Table 1 presents the modified Beaufort scale. Note that the effects listed in this table refers to wind conditions occurring frequently over the averaging time (a probability of occurrence exceeding 5%). Higher ranges of wind speeds can be tolerated for rarer events.

Table 1: Summary of Wind Effects on People (A.D. Penwarden, 1973)

Type of Winds	Beaufort Number	Mean Wind Speed (m/s)	Effects
Calm	0	Less than 0.3	Negligible.
Calm, light air	1	0.3 – 1.6	No noticeable wind.
Light breeze	2	1.6 – 3.4	Wind felt on face.
Gentle breeze	3	3.4 – 5.5	Hair is disturbed, clothing flaps, newspapers difficult to read.
Moderate breeze	4	5.5 – 8.0	Raises dust, dry soil and loose paper, hair disarranged.
Fresh breeze	5	8.0 – 10.8	Force of wind felt on body, danger of stumbling
Strong breeze	6	10.8 – 13.9	Umbrellas used with difficulty, hair blown straight, difficult to walk steadily, wind noise on ears unpleasant.
Near gale	7	13.9 – 17.2	Inconvenience felt when walking.
Gale	8	17.2 – 20.8	Generally impedes progress, difficulty balancing in gusts.
Strong gale	9	Greater than 20.8	People blown over.

It should be noted that wind speeds affecting this particular development can only be accurately quantified with a wind tunnel study. This assessment addresses only the general wind effects and any localised effects that are identifiable by visual inspection and the acceptability of the conditions for outdoor areas are determined based on their intended use. Any recommendations in this report are made only in-principle and are based on our extensive experience in the study of wind environment effects.

RESULTS AND DISCUSSION

The expected wind conditions affecting the development are discussed in the following sub-sections of this report for the various outdoor areas within and around the subject development. The interaction between the wind and the building morphology in the area is considered and important features taken into account including the distances between the surrounding buildings and the proposed building form, as well as the surrounding landform. Note that only the potentially critical wind effects are discussed in this report. A glossary of the different wind effects described in this report included in Appendix A.

For this assessment, the wind speed criteria for pedestrian comfort that are considered are listed as follows:

- Walking Criterion (8m/s with a 5% probability of exceedance)
for general circulation and pedestrian thoroughfares, e.g. footpaths, private balconies/terraces, through-site links etc.
- Standing (Short Exposure) Criterion (6m/s with a 5% probability of exceedance)
for stationary activities generally less than an hour, e.g. waiting areas, communal terraces, main entries, café seating etc.
- Sitting (Long Exposure) (4m/s with a 5% probability of exceedance)
for stationary activities longer than an hour, e.g. outdoor cinemas, outdoor fine dining etc.

Note that the above wind comfort levels are derived from the Lawson (1975) criteria. Although this assessment is qualitative in nature, the abovementioned criteria for pedestrian comfort are considered when assessing the wind environment impacts. However, all areas are also assessed with consideration to a pedestrian safety criterion of 23m/s for the annual maximum gust.

5.1 Ground Level Trafficable areas and Pedestrian Thoroughfares



The outdoor trafficable areas within and around the development site benefits from shielding provided by the subject and neighbouring easterly and southerly buildings. Down-wash wind effects off the tower façade are expected to be minimal due to the tower setback from the podium edge, and the wind mitigation provided by existing trees along Chapel Road and the proposed ground level awning as indicated in the architectural drawings. There are however outdoor areas that may be susceptible to stronger wind conditions due to the interaction of the prevailing winds with the building morphology, summarised as follows:

- The pedestrian thoroughfares along the Chapel Road and French Avenue frontages of the site are susceptible to direct winds travelling along these street scapes. It should be noted that this is an existing condition for the pedestrian thoroughfares.
- The proposed forecourt and outdoor seating may be susceptible to the prevailing southerly winds travelling along Chapel Road.

It is expected the following treatment strategies to be effective in mitigating the abovementioned potential wind effects and enhance the local wind conditions within the various outdoor trafficable areas within and around the site, hence they are recommended to be considered in the design of the development and are indicated in Figure 4.

- Retention of the proposed impermeable awning along the Chapel Road and French Avenue frontages of the site as indicated in the architectural drawings.
- The inclusion of the proposed densely foliating vegetation within the proposed raised planter zones as indicated in the landscape drawings.
- The inclusion of the proposed and existing densely foliating street trees along the Chapel Road and French Avenue frontages of the site as indicated in the architectural drawings.

Treatments Legend

-  Retention of the proposed impermeable awning, as indicated in the architectural drawings.
-  The inclusion of the proposed densely foliating vegetation within the raised planter zones as indicated in the landscape drawings.
-  The inclusion of the proposed and existing densely foliating street trees as indicated in the architectural drawings.

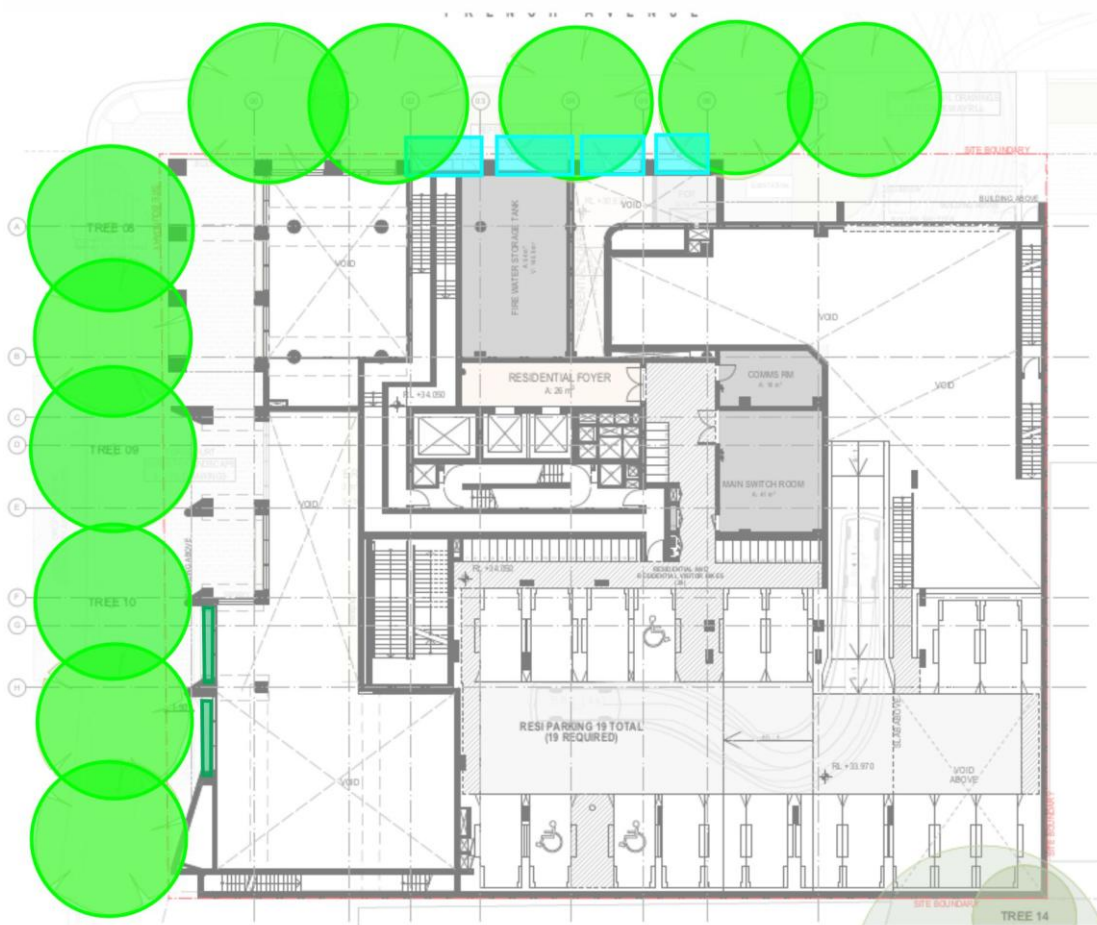

Figure 3: Recommended Treatments for the Ground Level

5.2 Elevated Communal and Shared Outdoor Spaces

The wind conditions within the proposed Level 01 ministry outdoor area and the Level 17 communal outdoor area are expected to be suitable for its intended use due to its centrally recessed design and shielding provided by the subject building-form.

The proposed Level 01 Early Learning Centre outdoor area benefits from the shielding provided by the subject building-form and the proposed 1.8m high impermeable screening along the entire perimeter edge of the outdoor area. Due to its relatively large area, it may be susceptible to reattachment flows as the prevailing winds travel over perimeter screening and around the corners of the building.

The Level 18 communal open space, benefits from some shielding provided by the central stair/liftcore and plant service areas and the pergola structure to any potential up-wash wind effect, however due to its elevated position relative to the surrounding low to mid-rise buildings, it is exposed to direct wind effects from the prevailing wind directions and corner accelerations around the central stair/liftcore.

It is expected the following treatment strategies to be effective in mitigating the abovementioned potential wind effects and enhance the local wind conditions within the aforementioned outdoor spaces, hence they are recommended to be considered in the design of the development and are indicated in Figures 5.

Level 01 Early Learning Centre Outdoor Area

- Retention of the proposed 1.8m impermeable screens along the exposed perimeter edge of the outdoor area as indicated in the architectural drawings.
- The inclusion of the proposed densely foliating vegetation within the planter zones as indicated in the landscape drawings.
- Consider the inclusion of additional wind mitigation elements such as screens or densely foliating vegetation around the corners of the building and areas intended for short duration stationary activities such as outdoor seating and play areas.
- Areas intended for short duration stationary activities such as outdoor seating are recommended to be restricted/situated away from the corners of buildings as these areas highly susceptibility to adverse wind conditions such as accelerating flows around the building.

Level 18 Communal Open Space

- Retention of the proposed 1.8m impermeable screens along the exposed perimeter edges of the communal open space as indicated in the architectural drawings.
- The inclusion of the proposed densely foliating vegetation within the planter zones as indicated in the landscape drawings.
- Areas intended for short duration stationary activities such as outdoor seating are recommended to be restricted/situated away from the corners of buildings as these areas highly susceptibility to adverse wind conditions such as accelerating flows around the building.

5.3 Elevated Private Balconies

The wind conditions within the various balconies of the development are expected to be suitable for their intended use due to the inclusion of various wind mitigation features such as their overall recessed design, impermeable balustrades, impermeable intertenancy screens, and full-height impermeable end screens. These features should be retained in the final design.

Davenport, A.G., 1972, "An approach to human comfort criteria for environmental conditions". Colloquium on Building Climatology, Stockholm.

Lawson, T.V., 1973, "The wind environment of buildings: a logical approach to the establishment of criteria". Bristol University, Department of Aeronautical Engineering.

Lawson, T.V., 1975, "The determination of the wind environment of a building complex before construction". Bristol University, Department of Aeronautical Engineering.

Lawson, T.V., 1980, "Wind Effects on Buildings - Volume 1, Design Applications". Applied Science Publishers Ltd, Ripple Road, Barking, Essex, England.

Melbourne, W.H., 1978, "Criteria for Environmental Wind Conditions". *Journal of Wind Engineering and Industrial Aerodynamics*, vol. 3, pp241-249.

Penwarden, A.D. (1973). "Acceptable Wind Speeds in Towns", *Building Science*, vol. 8: pp259-267.

Penwarden, A.D., Wise A.F.E., 1975, "Wind Environment Around Buildings". Building Research Establishment Report, London.

APPENDIX A WIND EFFECTS GLOSSARY

A.1 Downwash and Upwash Effects

The downwash wind effect occurs when wind is deflected down the windward face of a building, causing accelerated winds at pedestrian level. This can lead to other adverse effects as corner acceleration as the wind attempts to flow around the building, as seen in Figure A.1.

This can also lead to recirculating flow in the presence of a shorter upstream building, causing local ground level winds to move back into the prevailing wind.

The upwash effect occurs near upper level edge of a building form as the wind flows over the top of the building. This has the potential to cause acceleration of winds near the leading edge, as well as potentially reattaching onto the roof area. This effect causes wind issues particularly near the leading edges of tall building and on the rooftop areas if there is sufficient depth along the wind direction. Upwash is more apparent in taller towers and podia.

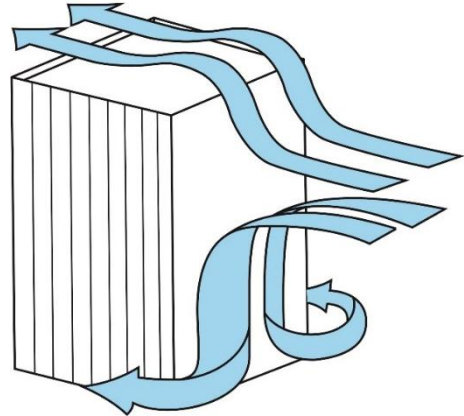

Figure A.1: Downwash Leading to Corner Wind Effect, and Upwash Effects

A.2 Funnelling/Venturi Effect

Funnelling occurs when the wind interacts with two or more buildings which are located adjacent to each other, which results in a bottleneck, as shown in Figure A.2. This causes the wind to be accelerated through the gap between the buildings, resulting in adverse wind conditions and pedestrian discomfort within the constricted space. Funnelling effects are common along pedestrian links and thoroughfares generally located between neighbouring buildings that have moderate gaps between them.

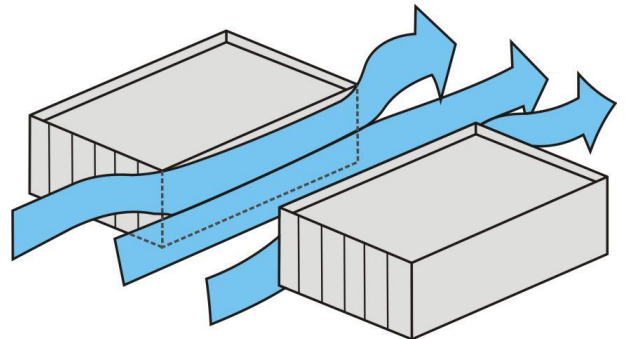

Figure A.2: Funnelling/Venturi Wind Effect

A.3 Gap Effect

The gap effect occurs in small openings in the façade that are open to wind on opposite faces, as seen in Figure A.3. This can involve a combination of funnelling and downwash effects. Presenting a small gap in the façade on the windward aspect as the easiest means through which the wind can flow through can result in wind acceleration through this gap. The pressure difference between the windward façade and the leeward façade also tends to exacerbate the wind flow through this gap.

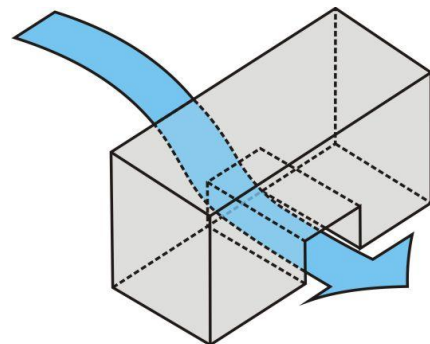

Figure A.3: Gap Wind Effect

A.4 Sidestream and Corner Effects

The sidestream effect is due to a gradual accumulation of wind shearing along the building façade that eventuates in an acceleration corner effect. The flow is parallel to the façade and can be exacerbated by downwash effects as well, or due to corner effect winds reattaching on the façade.

This is shown in Figure A.4. The corner refers to the acceleration of wind at the exterior vertical edge of a building, caused by the interaction of a large building massing with the incident wind, with the flow at the corner being accelerated due to high pressure differentials sets up between the windward façade and the orthogonal aspects. It can be further exacerbated by downwash effects that build up as the flow shears down the façade.

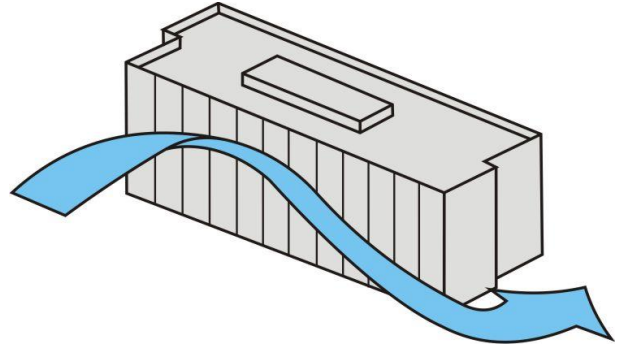

Figure A.4: Sidestream and Corner Wind Effect

A.5 Stagnation

Stagnation in a region refers to an area where the wind velocity is significantly reduced due to the effect of the flow being impeded by the bluff body. For a particular prevailing wind direction, this is typically located near the middle of the windward face of the building form or over a short distance in front of the windward face of a screen or fence. Concave building shapes tend to create an area of stagnation within the cavity, and wind speeds are generally low in these areas.