

BESS PACIFIC C/O GRANSOLAR DEVELOPMENT AUSTRALIA

FINLEY BESS

TRAFFIC IMPACT ASSESSMENT

Report No: P001993 TIA R01

Rev: D

3 February 2026



Premise

© Premise 2026

This report has been prepared by Premise Australia for BESS Pacific c/o Gransolar Development Australia; may only be used and relied on by BESS Pacific c/o Gransolar Development Australia; must not be copied to, used by, or relied on by any persons other than BESS Pacific c/o Gransolar Development Australia without the prior written consent of Premise. If BESS Pacific c/o Gransolar Development Australia wishes to provide this Report to a third party recipient to use and rely upon, the recipient agrees: to acknowledge that the basis on which this Report may be relied upon is consistent with the principles in this section of the Report; and to the maximum extent permitted by law, Premise shall not have, and the recipient forever releases Premise from, any liability to recipient for loss or damage howsoever in connection with, arising from or in the respect of this Report whether such liability arises in contract, tort including negligence.

DOCUMENT AUTHORISATION					
Revision	Revision Date	Proposal Details			
A draft	02/04/25	Issued for client's review			
B	08/04/25	Amended as per client comments			
C	02/05/25	Final			
D	03/02/26	Amended to address TfNSW comments			
Prepared By		Reviewed By		Authorised By	
Ana Marijanovic		Jennifer Evans		Daniel Balkin	<i>DB</i>
Marina Kleyweg	<i>M. Kleyweg</i>				

CONTENTS

EXECUTIVE SUMMARY	2
Proposed Project	2
Current Network	2
Anticipated Traffic Impact.....	2
1. INTRODUCTION	4
1.1 Background.....	4
1.2 Scope and Study Area	4
1.3 The Level of Assessment Required.....	7
1.4 Key Issues and Objectives of this Traffic Impact Statement.....	7
2. EXISTING CONDITIONS	9
2.1 Description of the site and proposed activity.....	9
2.2 Site location.....	9
2.3 Current land use zoning	9
2.4 Site access	11
2.5 Existing traffic conditions	11
2.5.1 ROAD NETWORK HIERACHY.....	11
2.5.2 EXISTING ROADWAY CONDITIONS.....	12
2.6 Traffic flow.....	13
2.6.1 EXISTING TRAFFIC FLOW.....	13
2.6.2 DESIGN SPEED	14
2.6.3 CURRENT TRAFFIC GENERATION OF SITE.....	14
2.6.4 CURRENT PERFORMANCE ASSESSMENT	15
2.7 Traffic safety	18
2.8 Parking Supply and Demand.....	18
2.9 Modal Split.....	19
2.9.1 RAV AND OSOM ROUTES.....	19
2.9.2 PUBLIC TRANSPORT	20
2.9.3 PEDESTRIAN NETWORK.....	20
2.10 Developments in the Vicinity.....	20
2.11 Consultation with Authorities	23
3. PROPOSED DEVELOPMENT	29
3.1 Overview of proposed development.....	29
3.1.1 STAGING AND TIMING OF DEVELOPMENT.....	30
3.1.2 SELECTION OF APPROPRIATE DESIGN VEHICLE.....	30
3.2 Access	31
3.2.1 ACCESS LOCATION	31
3.2.2 SIGHT AND STOPPING DISTANCE OF ACCESS LOCATION	33
3.2.3 SERVICE VEHICLE ACCESS.....	37
3.3 Circulation	37

3.3.1	PROPOSED PATTERN OF CIRCULATION	37
3.3.2	INTERNAL TRACK WIDTHS	37
3.3.3	SERVICE AREA LAYOUT	37
3.4	Parking.....	38
3.4.1	PARKING REQUIREMENTS	38
3.4.2	PROPOSED PARKING SUPPLY LAYOUT	38
4.	IMPACT OF PROPOSED DEVELOPMENT	39
4.1	Trip Generation	39
4.1.1	AVERAGE ANNUAL DAILY TRAFFIC (AADT)	39
4.1.2	PEAK HOUR.....	41
4.1.3	DAILY AND SEASONAL FACTORS	42
4.1.4	PEDESTRIAN GENERATION AND MOVEMENTS.....	42
4.1.5	PRE-CONSTRUCTION MINOR WORKS	42
4.2	Traffic distribution.....	43
4.2.1	HOURLY DISTRIBUTION OF TRIPS	43
4.2.2	TRIP DISTRIBUTION	43
4.3	Impact of generated traffic.....	44
4.3.1	IMPACT ON TRAFFIC SAFETY.....	44
4.3.2	IMPACT OF ANTICIPATED TRAFFIC ON KEY ROADS.....	46
4.3.3	POST 10 YEAR TRAFFIC FLOW.....	47
4.3.4	IMPACT OF EXPECTED TRAFFIC ON KEY INTERSECTIONS.....	48
4.3.5	IMPACT OF OTHER PROPOSED DEVELOPMENTS IN VICINITY	54
4.4	Assessment of Traffic Noise	55
4.4.1	NOISE ATTENUATION MEASURES.....	55
4.5	Recommended works.....	55
4.5.1	FINLEY BESS SITE WORKS	55
4.5.2	INTERSECTION OF RIVERINA HIGHWAY AND CANALLA ROAD	56
4.5.3	INTERSECTION OF CANALLA ROAD AND BROOCKMANN'S DRIVE.....	62
4.5.4	CANALLA ROAD AND BROOCKMANN'S DRIVE	62
5.	HEAVY VEHICLE AND OSOM ROUTES	63
5.1	Design Vehicle.....	63
5.2	Proposed OSOM Route	63
5.3	Railway Crossings.....	65
5.4	Bridges and Culverts	65
6.	CONCLUSION.....	66

TABLES

Table 1 – Level of assessment	7
Table 2 - Basic Road Classification	11

Table 3 - Classification of Key Roads Abutting Subject Site	11
Table 4 – 2011 AADT.....	13
Table 5 – Existing 2025 Peak Hour Traffic	14
Table 6 - Colour code based on Degree of Saturation	17
Table 7 - TfNSW Comments	24
Table 8 - Local Road Grades and Speed Limits.....	36
Table 9 - Local Sight Distance Requirements.....	36
Table 10 - Heavy vehicle movements.....	39
Table 11 - Workforce movements.....	40
Table 12 - Workforce monthly breakdown.....	40
Table 13 – AADT Generation for Proposed BESS.....	41
Table 14 – Cumulative Peak Hour Trip Generation for Proposed BESS during construction	42
Table 15 – Peak Hour Trip Generation for Proposed BESS during operation	42
Table 16 – Distribution of development-site-generated general peak hour traffic at the intersection of Riverina Highway, Canalla Road and Marantellis Road.....	44
Table 17 - AM peak turning volumes.....	44
Table 18 - PM Peak turning volumes	45
Table 19 – Comparison of Riverina Highway traffic volumes and net increase in trips	47
Table 20 - Parameters For User Classes - SIDRA model.....	49
Table 21 - Level of Service thresholds (SIDRA Models)	49
Table 22 - Colour code based on Degree of Saturation.....	54
Table 23 - Setting the context.....	57
Table 24 - Additional Safe System Components	61
Table 25 - Proposed truck stops for fatigue management (source: OSOM Route Survey, Ares Group, March 2025).....	65
Table 26 - Location of railway crossings (source: OSOM Route Survey, Ares Group, March 2025).....	65

FIGURES

Figure 1 - Impact Assessment Area.....	6
Figure 2 - Surrounding Area Land Use	10
Figure 3 - Marantellis Rd / Riverina Hwy / Canalla Rd intersection	12
Figure 4 - Canalla Road / Broockmanns Road intersection.....	13
Figure 5 - SIDRA Model Geometry.....	16
Figure 6 - SIDRA Model 2025 AM (No Development) – DoS	16
Figure 7 - SIDRA Model 2025 PM (No Development) – DoS.....	17
Figure 8 - TfNSW Crash Search Map	18
Figure 9 - B Double (25/26m) network in vicinity of the development site (source: NHVR)	19
Figure 10 - Surrounding Developments.....	22
Figure 11 - The largest vehicle anticipated to access the site (source: OSOM Route Study, Ares Group, 2025).....	30
Figure 12 - Proposed access points for light and heavy vehicles	32
Figure 13 - Assessing SISD (source AGtRD4A 2023)	33

Figure 14 – Car stopping sight distance.....34
 Figure 15 - Assessing SSD (source AGtRD3 2021)34
 Figure 16 - Assessing ASD (source AGtRD4A 2023).....35
 Figure 17 - Sight Distance Equation35
 Figure 18 – Major Road Turn Warrants – Right and Left Turn – AM peak45
 Figure 19 Major Road Turn Warrants – Right and Left Turn – PM peak46
 Figure 20 - SIDRA Model Geometry50
 Figure 21 - SIDRA Model 2026 AM (Development Construction) – Movement flows51
 Figure 22 - SIDRA Model 2026 AM (Development Construction) – DoS.....51
 Figure 23 - SIDRA Model 2026 PM (Development Construction) – Movement flows.....52
 Figure 24 - SIDRA Model 2026 PM (Development Construction) – DoS52
 Figure 25 - SIDRA Model 2036 AM (Post Development) – DoS53
 Figure 26 - SIDRA Model 2036 PM (Post Development) – DoS.....53
 Figure 27 - Proposed upgrade of Riverina Highway, Canalla Road and Marantellis Road intersection -
 BAL/BAR configuration.....56
 Figure 28 - Alternative configuration for Riverina Highway, Canalla Road, Marantellis Road intersection -
 CHR/AUL57
 Figure 29 - Proposed OSOM route for transformer transportation (source: OSOM Route Survey, Ares
 Group, January 2026).....64

APPENDICES

APPENDIX A TRAFFIC COUNT DATA67
 APPENDIX B SIDRA OUTPUT.....68
 APPENDIX C DEVELOPMENT SITE PLAN69
 APPENDIX D TFNSW REQUIREMENTS70
 APPENDIX E DRAFT TRAFFIC MANAGEMENT PLAN (TMP).....71

EXECUTIVE SUMMARY

Proposed Project

Premise Australia Pty Ltd (Premise) has been engaged by BESS Pacific c/o Gransolar Development Australia to undertake a Traffic Impact Assessment (TIA) for the proposed Finley BESS located on a portion of Lot 3 DP740920 at Riverina Highway, Finley New South Wales (NSW) 2713.

The proposed development will involve the development, construction, operation and eventual decommissioning of a BESS with a capacity of 100 MW/200 MWh connecting via underground transmission line (TL) under Broockmanns and Canalla Roads directly to the existing Transgrid Finley 132/66 kV transmission substation (Lot B DP961693). Collectively are hereafter referred to as 'the development site'.

Current Network

Access to the site is from Riverina Highway via Canalla Road, with heavy vehicle entry through a new crossover from Canalla Road. Two additional crossovers will be provided from Broockmanns Road for Transgrid (west) and light vehicles (east).

- > All roads have undivided carriageway with a speed limit of 100km/h and no pedestrian or cycling facilities.
- > Riverina Highway carries approximately 1,500-1,600 vehicular trips per day, with peak hour traffic being around 120 vehicular trips in peak hour.
- > There are no public transport services on adjacent roads apart from intercity buses.
- > Preliminary SIDRA Intersection analysis shows there is sufficient capacity on the local network to accommodate traffic from the proposed development.
- > Review of the available crash data shows there were no significant traffic crashes in vicinity of the development site.
- > The existing intersections on roads leading to the development site have appropriate sight distances to allow for the safe movement of both heavy and passenger vehicles.
- > The roads abutting the site offer no on-street parking at present. The development site is vacant agricultural land.

Anticipated Traffic Impact

The subject development will have three (3) key traffic generating stages:

- > Construction Stage (anticipated 55 FTE employees) – approximately 11 months duration (3 months peak);
- > Operational Stage (anticipated 2 FTE employees) – approximately 15-25 years duration; and
- > Decommissioning /Upgrading Stage (impact to be confirmed at later stage).

The key traffic impact on the network associated with the project is expected to occur during the construction stage. While a Construction Traffic Management Plan will be prepared at an appropriate stage of project, the TIA analysis will review cumulative anticipated impact of the construction stage.



The construction stage of Finley BESS is anticipated to generate 164 vehicular trips daily at the peak of construction. General peak hours for Finley BESS generated traffic will be aligned with construction site opening and closing times and will not align with the recorded peak network peak hours on Riverina Highway. During the general Finley BESS peak traffic, the construction site will generate up to 33 trips in peak hour. Peak heavy vehicle trips are likely to occur during the work hours, not coinciding with the Finley BESS general peak nor with the network peak. During the heavy vehicle peak hour, up to 10 movements (20 trips) are anticipated.

The majority of the traffic generated during the construction stage of the project will be generated by Austroads Class 1 and Class 2-9 vehicles (as-of-right vehicles). There would be one escorted over-dimensional vehicle round trip to and from the site delivering the transformer. The escorted over-dimensional vehicle movements have been the subject of a route assessment. Several over-dimensional or Special Purpose Vehicles (SPV) vehicles (not requiring escort) will be accessing the site during the construction.

Currently the Riverina Highway, Canalla Road and Marantellis Road intersection features an 85m left turn deceleration lane on to Canalla Road and a 75m left turn deceleration lane on to Marantellis Road. It is not anticipated there will be any additional impact on traffic safety through the increase of Finley BESS traffic using the existing intersection of Riverina Highway and Canalla Road.

Following discussions with the TfNSW, the Applicant will upgrade Riverina Highway, Canalla Road and Marantellis Road intersections to conform with the current Austroads requirements for BAL/BAR configuration.

SIDRA intersection analysis has been undertaken to assess the performance of the intersection of Riverina Highway, Canalla Road and Marantellis Road. The following scenarios were modelled: base traffic 2025, 2026 peak construction traffic and 2036 post development traffic volumes. Modelling shows that the Riverina Highway, Canalla Road and Marantellis Road intersection will continue to operate with a Level of Service A during the AM and PM peaks in its current geometric configuration. A turn warrant assessment has also been completed using the same data used in the SIDRA analysis, which demonstrates that the appropriate level of intersection is a basic access left (BAL) and basic access right (BAR). The project team developed an upgrade plan showing BAL/BAR intersection layout compliant to the current Austroads and TfNSW standards.

Preliminary desktop assessment suggests that all of the sight distance parameters (SISD/SSD/ASD) for Riverina Hwy / Canalla Rd and Canalla Rd / Broockmanns Rd intersections are satisfied, and the proposed crossovers can be designed to achieve necessary sight distances.

Independent OSOM Route Survey Report was prepared by Ares Group confirming that transportation of the Finley BESS transformer from Port of Melbourne to the development site is feasible.

In due course, the Applicant will require bridge and culvert assessment along the route as well as approval from V/Line to travel across two railway crossings.

In summary, out of three key phases, the construction phase of Finley BESS will have the strongest impact on the road network; however, the network has sufficient spare capacity to accommodate this impact. Operational phase of Finley BESS will have a negligible impact, while the impact of decommissioning phase should be assessed closer to the date.

1. INTRODUCTION

1.1 Background

Premise Australia Pty Ltd (Premise) have been commissioned by the BESS Pacific c/o Gransolar Development Australia to prepare a Transport Impact Assessment (TIA) to support State Significant Development Application (SSD-72430958) for a proposed Battery Energy Storage System (BESS) and ancillary infrastructure including transmission and connection works at Lot 3 DP 740920 Riverina Highway (HW20), Lot B DP 961693 Finley NSW 2713, and Broockmanns and Canalla Roads, referred to as “development site” from here on. The proposed development is known as Finley BESS and is located within the Berrigan Shire Council (BSC) Local Government Area (LGA).

At present, the development site is zoned Primary Production (RU1) and is used for agricultural and grazing activities. The proposed BESS site is free of supporting structures while the existing Transgrid site features a central service shed with transformers, transmission lines and other specialist equipment.

Access to the development site is from Riverina Highway via Canalla Road for heavy vehicles, and via Broockmanns Road for Transgrid vehicles and light vehicles.

1.2 Scope and Study Area

Figure 1 shows the impact assessment area consisting of the proposed Finley BESS location and the site access off Riverina Highway, Canalla Road, and Broockmanns Road.

The scope of works includes the following key infrastructure:

- > Site establishment works including clearing of grassed area within the Finley BESS, bulk earthworks and temporary construction compound;
- > Construction of hardstand, control room and switch gear, auxiliary transformer, battery enclosures, and inverter and transformer stations;
- > Development site road works to formalise internal access road to accommodate heavy vehicles movements off Canalla Road and two light vehicle accesses to Broockmanns Road;
- > Installation of approximately 80 20-foot modular containers comprising of Lithium-Ion batteries with the appropriate cooling and protection system and approximately 40 inverters (one per every two batteries) located externally to the modular containers;
- > Construction of 132 kV TL route ~480m length underground transmission line to facilitate connection to the existing Transgrid Finley 132/66 kV Substation and associated high voltage steel poles;
- > Construction of ancillary works including parking areas, water tanks, storage structures, stormwater management infrastructure, CCTV, security lighting and fencing; and
- > Vegetation buffer.



Ancillary to the Finley BESS would be associated the Transgrid substation upgrade works occurring within Lot B DP 961693. Underground transmission line connection include crossing Broockmanns Road, Canalla Road and Mulwala No. 19 channel via underbore a to traverse the land owned by Transgrid (Lot B DP961693) and connection to the substation.

The areas directly impacted by the Finley BESS infrastructure, including the access driveway, Finley BESS area, substation and connection of electricity transmission lines will be collectively referred to as the 'development site'.

The development site is not located within a Renewable Energy Zone (REZ).



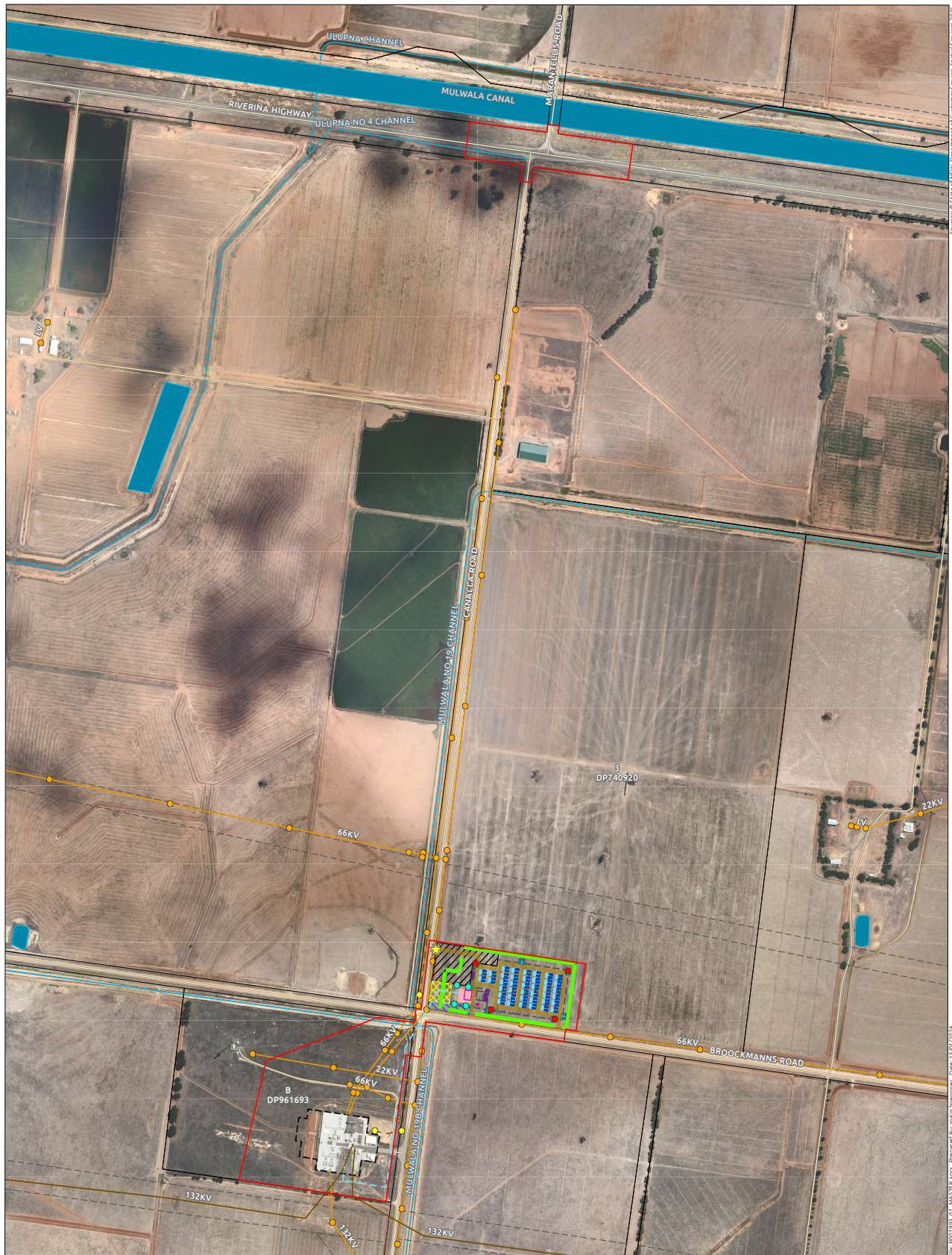

Source: © State of NSW, Department of Customer Service, 2024; Surveyor General, 2024; Department of Planning, 2024; Planning 2022

Grandiose Development 2024; Neermap 2023

File: P001993_G1_MASTER.aprx Prepared By: mdm/hspepper Date: 15/01/2026

- | | | | |
|---|---|---|---|
| Legend | | | |
| Development Site | ● Essential Energy Pole | — Gate | - - - Fence |
| ☀ Primary Site Access (Heavy Vehicle) | ● Transgrid Pit | — Screening Vegetation | - - - Proposed UG Connection line |
| Lot | Proposed Development | ● Watertank | ● CCTV Mast |
| — Road | Substation Switch Area | ● BESS Lighting Mast | |
| — Water Body | Internal Road | | |
| — Watercourse | Temporary Facilities | | |
| Existing Substation | Car Parking | | |
| Existing Easement | Laydown | | |
| — Essential Energy OH | Site Offices | | |
| — Essential Energy UG | BESS Substation | | |
| — Transgrid OH | BESS Buildings | | |
| — Transgrid Optic Fibre | — Battery | | |
| | — Inverter | | |



Finley BESS

Figure 1
Impact Assessment Area

1.3 The Level of Assessment Required

The Guide to Transport Impact Assessment, recently published by TfNSW as an update to Guide to Traffic Generating Developments, stipulates the following criteria for determining an appropriate level of assessment:

Table 1 – Level of assessment

Type of Report	Description
Transport Impact Statement (TIS)	<p>The TIS is to be used for developments which size or capacity and their site access(es) to adjoining road do not exceed the thresholds as defined in Columns 2 and 3 of Schedule 3 in the State Environmental Planning Policy (Transport and Infrastructure) 2021.</p> <p>The statement is intended to collect factual information about the proposed development such as site location and context, development scale, access arrangements, trip generation and distribution.</p>
Transport Impact Assessment (TIA)	<p>The TIA is to be used for developments which size or capacity and their site access(es) to adjoining road meet or exceed the thresholds as defined in Columns 2 and 3 of Schedule 3 in the State Environmental Planning Policy (Transport and Infrastructure) 2021.</p>

The proposal seeks to establish a Battery Energy Storage System (BESS); therefore, in the long-term – there will be no notable traffic increase in the operational (post-construction) phase. *State Environmental Planning Policy (Transport and Infrastructure) 2021* Schedule 3 identifies the appropriate level of assessment for this development is a Transport Impact Statement (TIS). However, pre-SEARs advice from the Transport for New South Wales (TfNSW) requests a Transport Impact Assessment (TIA) to be prepared.

The main traffic impact is expected during the construction and decommissioning phase, and this will be addressed in detail via a Construction Traffic Management Plan that is to be submitted at an appropriate project stage.

This report will consider the impact of construction traffic broadly and will focus on the access requirements for an appropriate Over Size Over Mass (OSOM vehicle).

1.4 Key Issues and Objectives of this Traffic Impact Statement

The objective of this Transport Impact Assessment (TIA) is to estimate, evaluate and mitigate the expected impact resulting from the construction and operational stage of the Proposal on the surrounding road network. The assessment has been undertaken in accordance with the Secretary’s Environmental Assessment Requirements (SEARs).



Transport For New South Wales (TfNSW) has provided a preliminary advice, requesting preparation of a Transport Impact Assessment (TIA) to address a range of factors:

- > Review the existing state of the relevant network;
- > Review known and committed planning proposals (strategic document and known plans) to estimate impact on the network that can be expected from other projects;
- > Assess the anticipated impact of the proposed development in construction and during the exploitation;
- > Desktop review access and parking arrangements on the site;
- > Desktop review applicable OSOM access routes;
- > Vertical obstructions (overpasses, overhead power, large and dense tree canopy);
- > Horizontal obstructions (tight intersections, proximity of building lines obstructing manoeuvres, inadequate carriage width etc.);
- > Other obstructions (weight access limitation, dangerous goods access limitations etc);
- > SIDRA Intersection model of Riverina Highway, Canalla Road and Marantellis Road intersection and the assessment of the construction impact; and
- > Provide a comprehensive report detailing all findings and recommendations, inclusive of all plans, graphic, diagrams and calculations in draft and final format.

Full details of TfNSW requirements are provided in **Appendix D**. A high-risk over-dimensional heavy vehicle route assessment was prepared by Ares Group, who are a specialised logistics contractor and provided as a part of EIS submission. This TIA relies on the findings of the Ares route assessment report in the review of requirements for OSOM vehicle access.



2. EXISTING CONDITIONS

2.1 Description of the site and proposed activity

The proposed Finley BESS is located on a portion of Lot 3 DP740920 at Riverina Highway, Finley New South Wales (NSW) 2713.

The portion of the development site that will host the Finley BESS infrastructure is agricultural in nature is vacant of supporting structures. The remainder of the development site consists of the Broockmanns and Canalla Roads (road reserves) and Lot B DP961693, the Transgrid Zone substation, together with vacant land.

Access to the site is from Riverina Highway via Canalla Road for heavy vehicles, and via Broockmanns Road for Transgrid vehicles and light vehicles.

The Project will involve the development, construction, operation, and eventual decommissioning of a Finley BESS with a capacity of 100 MW_{AC}, 200 MWh connecting via underground TL directly to the existing Transgrid Finley 132/66 kV substation.

The construction timeframe for the project is approximately 10 months, with construction works expected to occur 5.5 days per week – Monday to Friday regular hours and half day on Saturday.

2.2 Site location

The site is located on a portion of Lot 3 DP740920 at Riverina Highway, Finley New South Wales (NSW) 2713, approximately 5 km west of the town of Finley.

The proposed access to the site is approximately 1.5 kilometres south of Riverina Highway on Canalla Road.

2.3 Current land use zoning

The development site is currently zoned Primary Production (RU1) and is located within the Berrigan Shire area. Land use surrounding the development site is generally zoned as Primary Production (RU1) as shown by **Figure 2** - Surrounding Area Land Use

.





Sources: © State of NSW, Department of Customer Services, Spatial Services, 2025
 © State of NSW, Department of Climate Change, Energy, the Environment and Water 2025
 © Nearmap 2025

File: P001993_01_MASTER.aprx Prepared By: zindia.narver Date: 03/04/2025

Legend

- | | | |
|--------------------------------|-----------------------------------|---|
| Locality (1km Buffer) | Watercourse | 5.4.0 Residential and farm infrastructure |
| Development Site | Land Use 2017 | 5.7.0 Transport and communication |
| BESS Lease Area | 2.1.0 Grazing native vegetation | 6.4.0 Channel/aqueduct |
| Substation | 3.2.0 Grazing modified pastures | |
| Indicative BESS Security Fence | 3.3.0 Cropping | |
| Lot | 4.3.0 Irrigated cropping | |
| Road | 5.2.0 Intensive animal production | |
| Water Body | | |



Premise
 Finley BESS

Figure 2
 Surrounding Land Uses

2.4 Site access

Access to the site is from Riverina Highway via Canalla Road, with entry through a heavy vehicle entrance from Canalla Road. An existing entrance in Broockmanns Road will be upgraded to provide for light vehicles and a new entrance via Broockmanns Road installed for dedicated use by Transgrid vehicles.

Riverina Highway and Canalla Road intersection as well as the intersection of Broockmanns Road and the proposed development crossover form a standard Tee-Intersection.

Canalla Road and Broockmanns Road form a full movement 4-way intersection.

2.5 Existing traffic conditions

2.5.1 ROAD NETWORK HIERACHY

The *Roads Act 1993* outlines following road classes: State Roads, Regional Roads and Local Roads.

The administration and management of State Roads is carried out and financed by TfNSW while Regional and Local Roads are administered, managed and financed by local councils.

Regional Roads perform an intermediate function between the main arterial network of State Roads and council-controlled Local Roads. Due to their network significance, TfNSW provides financial assistance to councils for the management of Regional Roads.

Furthermore, the *Roads Act 1993* provides the basis for the core legal classification of classified and unclassified roads. **Table 2** below shows basic road classification.

Table 2 - Basic Road Classification

Legal Classification	Administrative Classification		
	State Roads	Regional Roads	Local Roads
Classified	Always	Sometimes	Never
Unclassified	Never	Often	Always

Classified roads can be further delineated in the following categories: Freeways, Controlled Access Roads, Tollways, State Highways, Main Roads, Secondary Roads, Tourist Roads, Transitways and State Works.

Table 3 outlines the basic classification of existing roads in the vicinity of the development site.

Table 3 - Classification of Key Roads Abutting Subject Site

	Administrative Class	Legal Class	Note
Riverina Highway	State	Classified	Road number 20
Canalla Road	Local	Unclassified	n/a
Broockmanns Road	Local	Unclassified	n/a



2.5.2 EXISTING ROADWAY CONDITIONS

The existing roadway configuration, conditions and intersection facilities of the surrounding road network are outlined in the following sections of the report. There are currently no known current or proposed roadworks, traffic management works or bikeways proposed for the section of roads analysed within this assessment.

2.5.2.1 Key Roads

Riverina Highway is a State Road spanning 220km from Bethanga Bridge over the Murray River to the Cobb Highway at Deniliquin. In the vicinity of the development site the highway is a two-way, two-lane carriageway with 3.5 m wide traffic lanes in each direction and a speed limit of 100km/h.

Canalla Road and Broockmanns Road are both partially paved roads in a 20m road reserve providing connectivity for the rural areas south of Riverina Highway. Both roads have a speed limit of 100km/h which is unlikely to be achieved bearing in mind the roads are only partially paved.

2.5.2.2 Key Intersections

The development site would be accessed via Riverina Highway intersection with Canalla Road and Canalla Road intersection with Broockmanns Road.

Riverina Highway and Canalla Road intersection forms a staggered T-intersection with Riverina Highway/intersection, which is located approximately 30m to the east of Riverina Highway and Canalla Road Tee-Intersection (centreline to centreline). The intersection has deceleration lanes to both minor roads and provides line marking to accommodate the movement of large trucks. There are two coach stops on each side of Riverina Highway in the immediate vicinity of the intersections (**Figure 3**).

Figure 3 - Marantellis Rd / Riverina Hwy / Canalla Rd intersection



Canalla Road and Broockmanns Road intersection is a full movement sign controlled 4-way intersection with Canalla Road as the minor road (**Figure 4**).

Figure 4 - Canalla Road / Broockmanns Road intersection



2.6 Traffic flow

2.6.1 EXISTING TRAFFIC FLOW

2.6.1.1 Average Annual Daily Traffic (AADT)

Annual Average Daily Traffic (AADT) is defined as the total volume of traffic passing a roadside observation point over a period of a year divided by the number of days in the year.

AADT data on Riverina Highway, sourced from the TfNSW Traffic Volume Viewer, 5km east from the proposed site access are provided in **Table 4** below.

Table 4 – 2011 AADT

Location	Average Annual Daily Traffic (AADT – trips/day)	Heavy Vehicles (%)	Mean Speed (km/hr)	85% Speed (km/hr)
Riverina Highway EB 110m West of Hamilton Street (2011)	764	18.8%	N/A	N/A
Riverina Highway WB 110m West of Hamilton Street (2011)	745	20.4%	N/A	N/A

2.6.1.2 Peak Hour Traffic Volumes

The data available via TfNSW Traffic Volume Viewer is dated (older than 3 years) and located 5km from the development site access. Therefore, the proponent commissioned Matrix to complete a 3-day traffic survey in period 18th to 20th February 2025. Data was collected at the intersection of Riverina Highway, Canalla Road and Marantellis Road for the AM and PM peak times.

Analysis of the provided data identifies the average peak hour times and traffic flows as outlined in **Table 5**.

Table 5 – Existing 2025 Peak Hour Traffic

Location/Direction	Time	Peak Hour Traffic (Veh/hr)		
		Total	Light Vehicles	Heavy Vehicles
Canalla Road northbound	Morning Peak - 08:00-09:00	1	1	0
	Evening Peak - 15:00-16:00	2	1	1
Canalla Road southbound	Morning Peak - 08:00-09:00	2	1	1
	Evening Peak - 15:00-16:00	0	0	0
Riverina Highway eastbound	Morning Peak - 08:00-09:00	57	46	12
	Evening Peak - 15:00-16:00	59	47	12
Riverina Highway westbound	Morning Peak - 08:00-09:00	53	38	15
	Evening Peak - 15:00-16:00	59	45	15
Marantellis Road northbound	Morning Peak - 08:00-09:00	1	1	0
	Evening Peak - 15:00-16:00	1	1	0
Marantellis Road southbound	Morning Peak - 08:00-09:00	2	2	0
	Evening Peak - 15:00-16:00	1	0	1

2.6.2 DESIGN SPEED

As mentioned in **Section 2.5.2.1**, the posted speed of Riverina Highway is 100km/hr. For this report, a design speed of 110km/hr has been adopted, 10km/hr above the posted speed of the road. As this speed is likely to be lower at different sections due to roadway conditions, this is deemed to be conservative.

2.6.3 CURRENT TRAFFIC GENERATION OF SITE

Lot 3 DP 740920 is primarily used for agricultural activities including irrigated agriculture and grazing. The development site is generally cleared of vegetation due to historic agricultural activities, with remaining vegetation comprising a mixture of exotic grassland and limited native vegetation. The development site does not contain any dwellings. Traffic generated by current activities at the development site is expected to be negligible and seasonal in nature.



2.6.4 CURRENT PERFORMANCE ASSESSMENT

Intersection (and access) performance has been assessed using SIDRA Intersection Version 9 Network (SIDRA). SIDRA is an advanced micro-analytical traffic tool for evaluation of intersections. The SIDRA network model determines the backward spread of congestion as queues on downstream lanes block upstream lanes and applies capacity constraint to oversaturated upstream lanes, thus limiting the flows entering downstream lanes.

SIDRA reports intersection performance in terms of a range of parameters including:

- > **Demand Volumes (V):** The modelled number of vehicles arriving at the intersection during the assessment hour. Demand volumes are calculated by dividing the peak hour volume by the peak flow factor (PFF). SIDRA's default PFF of 95% has been adopted for all movements,
- > **Degree of Saturation (DoS):** The ratio of the demand volume, V, to the theoretical capacity. An intersection is considered to be operating at its practical capacity when the DoS reaches 0.80 for priority control, 0.85 for a roundabout and 0.90 for traffic signals,
- > **Average Delay (D):** The mean control delay including both queuing delay and geometric delay for all vehicles arriving during the assessment period including the delay experienced after the end of the flow period until the departure of the last vehicle arriving during the flow period, and
- > **95th Percentile Back of Queue Length (Q):** The maximum backward extent of the queue relative to the stop line or give-way / yield line during a signal cycle or gap acceptance cycle below which 95% of all queue lengths fall. The 95th percentile back of queue length is generally accepted as the maximum queue length for design purposes.

2.6.4.1 Riverina Highway, Canalla Road and Marantellis Road Intersection – Pre-Development Conditions

Pre-development intersection analysis has been undertaken based on the existing 2025 traffic volumes.

The intersection performance is based on estimated pre-development traffic in 2025 (base year) for both the AM (09:00 – 10:00) and PM peak (15:15 – 16:15) for the highest survey traffic volumes to assess the worst-case scenario.

To be able to adequately model the staggered T intersection, SIDRA Network model has been used.

It has been conservatively assumed for this analysis that the peak hour traffic flows for all the roads are aligned.



Figure 5 - SIDRA Model Geometry

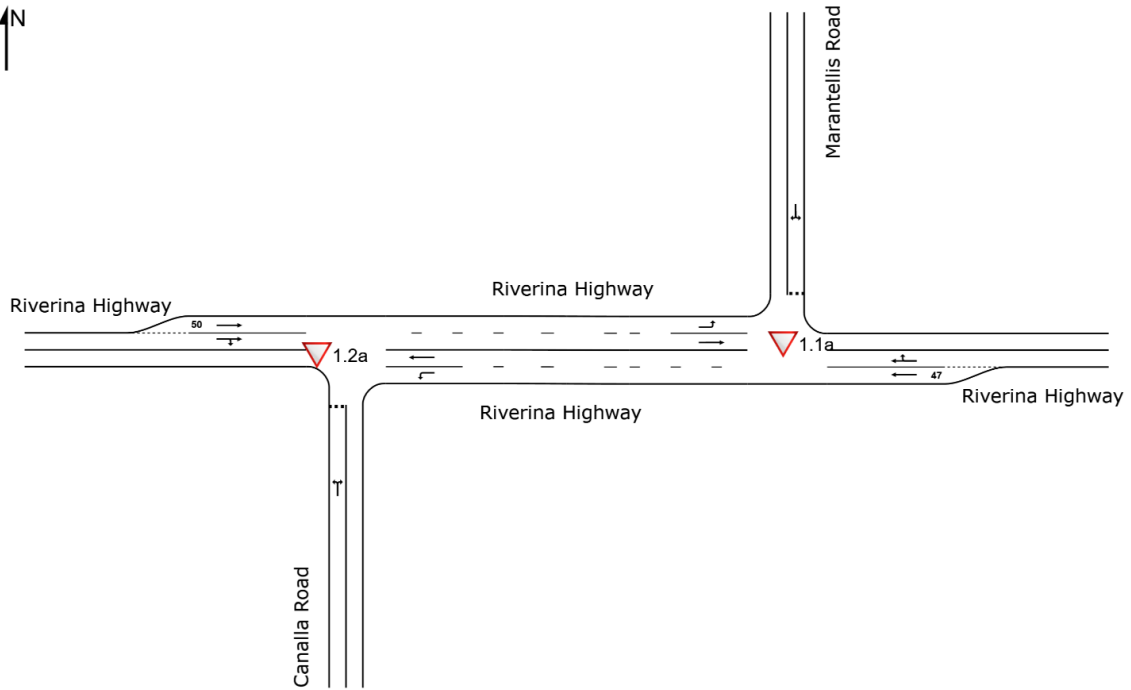

Figure 6 - SIDRA Model 2025 AM (No Development) – DoS

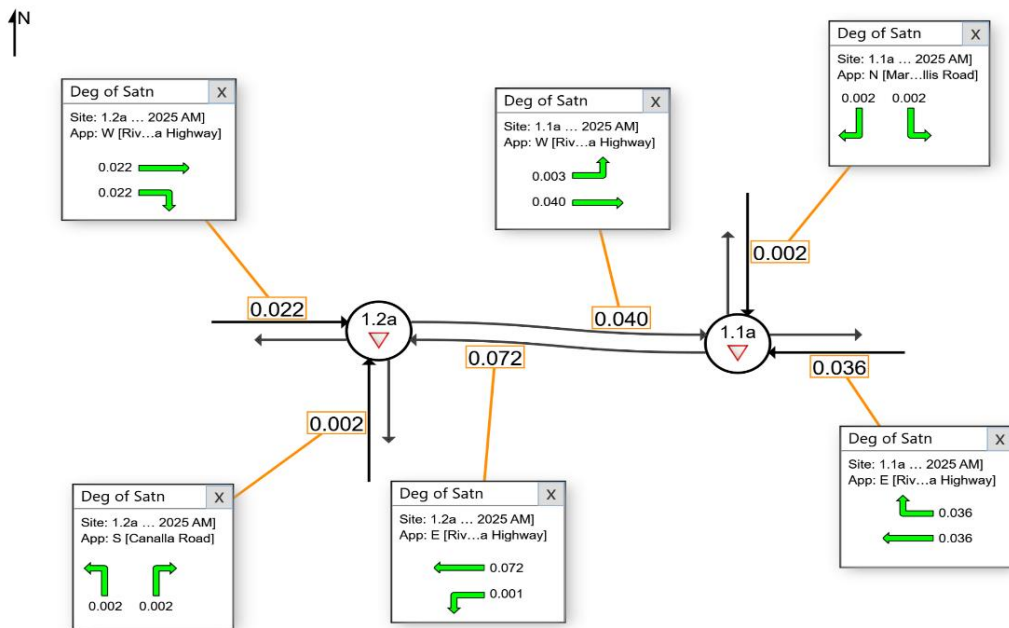

Figure 7 - SIDRA Model 2025 PM (No Development) – DoS

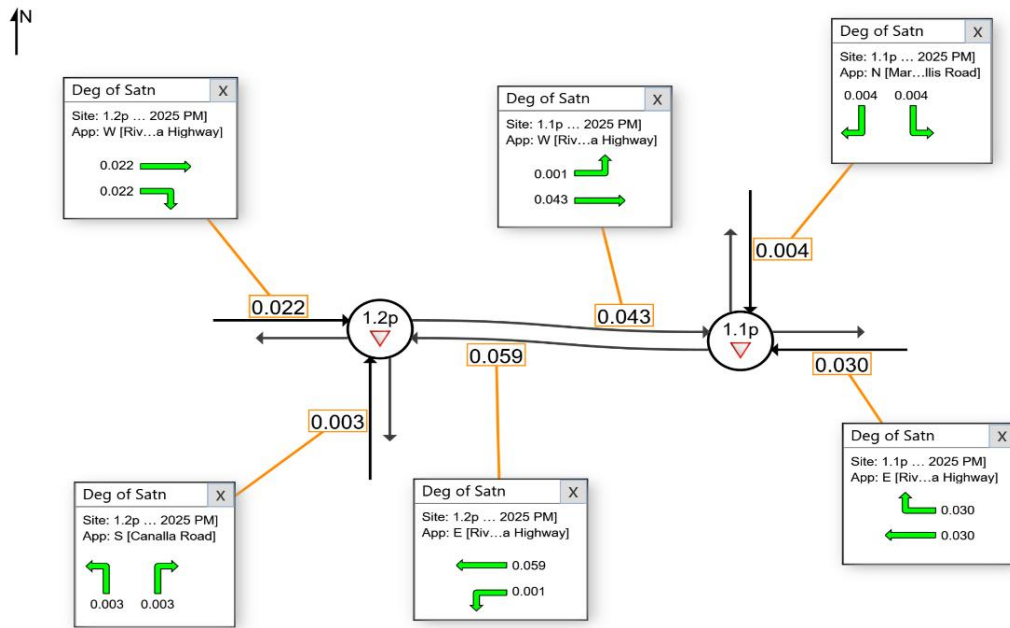
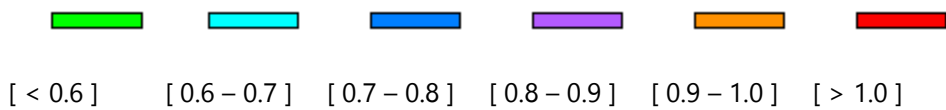

Table 6 - Colour code based on Degree of Saturation



and **Figure 7** show the network performance in AM and PM peak based on Degree of Saturation (DoS). All movements in the network show Level of Service A (low level of saturation) clearly demonstrating there is sufficient spare capacity in the network to accommodate additional traffic.

Appendix B shows SIDRA output results with key outputs from the SIDRA model. The results are summarised below:

- > The overall degree of saturation (DoS) for the network is 0.072 for the AM and 0.059 for the PM Peak Hour.
- > The maximum control delay for the worst movement is 8.0 seconds, which is for the Marantellis Road approach right turn during the PM peak.
- > No queuing is anticipated for either the AM or PM peak.
- > The level of service for each leg of the intersection is Level of Service A for both the AM and PM peak hour.

2.7 Traffic safety

A review of the TfNSW Centre for Road Safety Crash and Casualty Statistics database for all injury crashes along Canalla Road in the vicinity of the site has been carried out. The crash database provides the location and severity of all injury and fatal crashes for the five-year period from 2019 to 2024. The crash search recorded 2 non-casualty crashes one on Brookmans Road and one on Canalla Road, with the location of the crashes as shown in **Figure 8**.

Figure 8 - TfNSW Crash Search Map

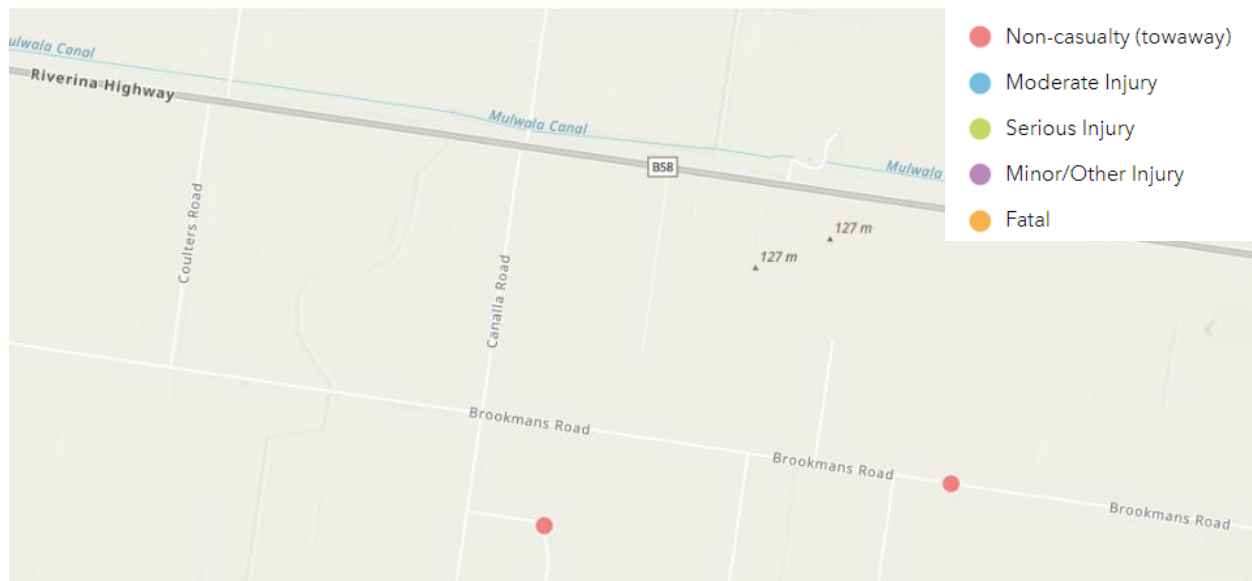

The crash and injury type are summarised below:

- > One off road right on left bend hitting object or parked vehicle resulting in no casualties; and
- > One off road to the right resulting in no casualties.

Of the above recorded incidents, there does not appear to be any pattern or any locations of re-occurring similar incidents that would highlight sections of the road being excessively unsafe. The number and type of incidents recorded are consistent with other rural classified roads in the area.

Given the class of road and crash types, it is concluded that the road network is currently operating in a manner consistent with rural local roads.

2.8 Parking Supply and Demand

As the proposed development is on a rural property fronting a rural arterial road and there is currently no on-street parking provisions and/or demand. The current site has no activity and therefore no parking demand.

2.9 Modal Split

2.9.1 RAV AND OSOM ROUTES

The Riverina Highway in this location is shown on the NHVR Restricted Access Route Map as being able to accommodate up to 26 metre B-Doubles and Class 1 OSOM vehicles.

Figure 9 - B Double (25/26m) network in vicinity of the development site (source: NHVR)

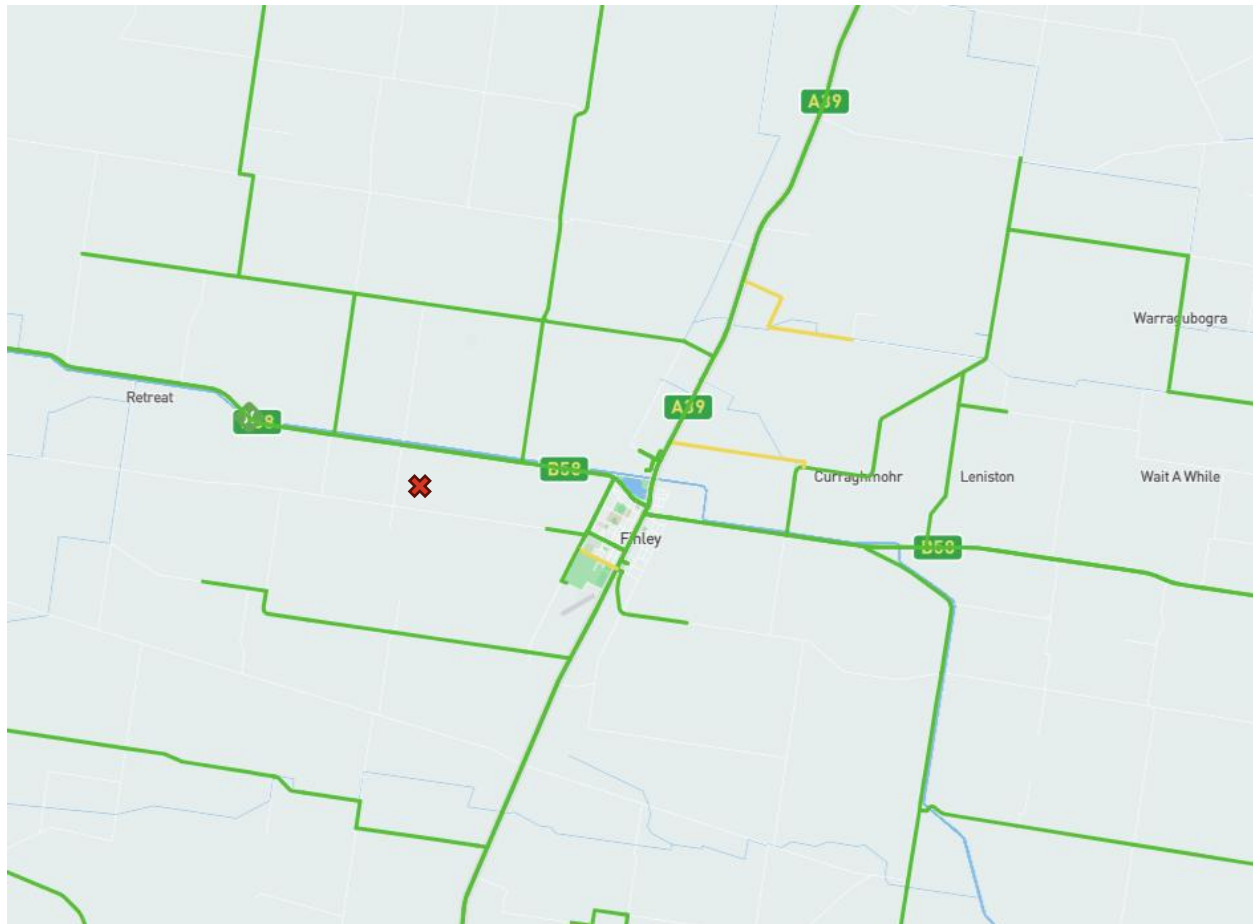

It is likely during construction that some larger vehicles will be required to transport large construction equipment and/or construction materials to the site and that these will exceed General Access (GAV) heavy vehicles sizes for the road network. For the purposes of this assessment, it has been assumed that any vehicles larger than these vehicles will be capable of meeting the Class 1 exemption for Oversize and Overmass (OSOM) load carrying vehicles. Given the applicant's experience with other projects of this nature, this assumption is reasonable. The findings of OSOM Route Study, prepared by Ares Group are summarised in **Section 5**.

Canalla Road is not a part of RAV or OSOM route, therefore separate applications will be required to enable access for these types of vehicles.

2.9.2 PUBLIC TRANSPORT

The proposed Finley BESS is located in a rural setting, approximately 1.5km south of the Riverina Highway.

There are currently no public transport services, apart from intercity coaches, operating on Riverina Highway which would be suitable to allow for site personnel to travel to and from the proposed site. The closest bus stop is located in Finley town and operates intercity buses.

There are no railway stations located in the vicinity of the proposed site.

2.9.3 PEDESTRIAN NETWORK

As mentioned above, the proposed site is approximately 1.5km south of the Riverina Highway. As such there are no existing pedestrian routes, pedestrian infrastructure and therefore no potential areas where pedestrian flows might conflict with vehicles.

2.10 Developments in the Vicinity

A review of BSC's website has not identified any future developments planned within the locality of the development.

A review of the NSW major projects planning portal application tracker, however, has identified several other state significant projects. Major projects in proximity are shown in **Figure 10** and include

- > South Coree BESS (SSD-77238990) is proposed to be located immediately adjacent to the development site, with the corresponding BESS situated generally to the east of Finley BESS at 384 Broockmanns Road. This development application is currently in planning and awaiting the preparation of an EIS. The proposed layout for South Coree BESS, as presented in the Scoping Report prepared by NGH Pty Ltd (2024).
- > Berrigan BESS (SSD-78106206) is proposed to be located immediately adjacent to the development site, north of Finley Substation, with the corresponding BESS situated generally to the west of Finley BESS, at 16891 Riverina Highway. This development application is currently in planning and awaiting the preparation of an EIS. The proposed layout for Berrigan BESS, as presented in the scoping report prepared by Cogency Australia Pty Ltd (2024).
- > Finley Solar Farm (SSD – 8540) which was originally approved on 29 January 2018 and is located immediately adjacent to the southwest of the development, south of Finley Substation. The solar farm received a subsequent approval for a modification for a substation upgrade on 4 June 2018 and is currently operational. The current approved layout for Finley Solar Farm, as presented in the latest modification application report prepared by ESCO (2018).
- > Tarleigh Park Solar Farm (SSD – 8436) which was approved on 18 May 2018 and is located approximately 25.5 km west of the development site at 260 Parfreys Road, Blighty.
- > Finley South Solar Farm (SSD-10299) located approximately 9.8 km southwest of the development site at 670 Lawlors Road, Finley. This development application was withdrawn following issue of the issue of SEARs dated 9 May 2019.



All other existing land uses surrounding the development site are expected to continue into the future. As detailed via the EIS the project design has been refined to limit impacts to surrounding land uses.

Two proposed adjoining developments will share the same access network (Riverina Highway, Canalla Road, Broockmanns Road); however, at present there is no evidence that the construction will occur on all three sites simultaneously. Furthermore, there is no data on anticipated traffic generation as EIS reports for these projects have not yet been submitted.





- Legend**
- Development Footprint
 - Lot
 - Road
 - Water Body
 - Watercourse
 - Solar Farm
 - South Coree BESS
 - Berrigan BESS



Figure 10
Surrounding Development

Sources: © State of NSW, Department of Customer Service, Spatial Services, 2025 © ESRI 2025
File: P001993_01_MASTER.aprx Prepared By: zindia.narver Date: 19/01/2026

2.11 Consultation with Authorities

TfNSW reviewed and provided comments on the Revision B of the TIA (ref: REN25/00086/002). The feedback focused on the traffic impact and safety of the key intersection of Riverina Highway and Canalla Road and the proposed arrangements for access of OSOM vehicles. This Rev D TIA has been updated to address those comments in **Section 4.3** of the TIA.



Table 7 - TfNSW Comments

Comment		Section Addressed
<p>Key Issue 1 - Traffic Impact Clarifications</p>	<p>Section 4.3.1 of the TIA notes that the turn warrants assessment focuses on the AM peak. The reason given is that the AM peak is likely to generate the highest number of trips, which determines the intersection treatments. The turn warrant assessment is to be revised to include the PM peak hour traffic volumes for project traffic at peak of construction. The turn warrant assessments are to be prepared in accordance with section 3.25 of Part 6 of the Austroads Guide to Traffic Management (see advisory note 6).</p>	<p>Section 4.3.1 – Impact on Traffic Safety</p> <p>PM assessment added.</p>
	<p>The AM and PM peaks identified in the SIDRA analysis differ from those used in the turn warrant assessment. The SIDRA analysis on page 4.3.4.1 indicates that the worst-case scenario using the Wednesday background traffic data was used, whilst in Section 3.6.1.2, an average was used across all days. It is essential to understand the AM and PM peaks, as they inform the worst-case scenario applied to the turn warrants. The TIA is to be revised to ensure that the SIDRA analysis and turn warrants assessment represent the same worst-case scenario for the AM and PM peak hours at the peak of construction.</p>	<p>Section 4.3.1 – Impact on Traffic Safety</p> <p>Data sources harmonised.</p>
<p>Key issue 2: Issues with utilising existing turn treatments</p>	<p>Issue with using the existing Auxiliary Left Turn treatment (AUL)- Canalla Road/Riverina Highway</p>	<p>Addressed through concept design showing proposed improvements.</p>



	Issue with the existing Basic Right Turn treatment (BAR)- Canalla Road/Riverina Highway	Section 4.5.2 Intersection of Riverina Highway and Canalla Road.
	Road Train width requirement	
	Swept Paths	
	Consideration of bus bays	
	Broockmanns Road consideration	
Key Issue 3 - Staging and pre-construction minor works	Identification of the traffic volumes and traffic types, inclusive of the largest design vehicle, including those specifically in the AM/PM peak hours. Swept path analysis is required for the existing intersection if concurrent turning movements for the design heavy vehicle are intended at this intersection during the pre-construction minor works phase.	Pre-construction minor works were included in the impact assessment. This distinction was clarified throughout the report.
	Identification of any measures proposed to reduce the project traffic and impacts during this period, i.e carpooling, shuttle buses, staggering of traffic and inclusion of enforceable mitigation measures that can be monitored for compliance.	
	Provide a schedule of the proposed pre-construction minor works and program of works. Identifying the hours for pre-construction minor works.	
	Assess any overlap of construction and pre-construction minor works periods must be included in the traffic assessment for this stage, before completion of the intersection upgrade.	



<p>Key Issue 4 – The high-risk OSOM route assessment scope and mitigation measures</p>	<p>NHVR Route ID has not been provided. This is required to ensure a complete assessment of route considerations has been provided. See advisory note 4.</p>	<p>OSOM route assessment report was updated, provided as an appendix to EIS and the summary of the report is outlined in Section 5.</p>
	<p>The route assessment identifies heavy-massed and large-axle group load vehicles. Bridge and culvert assessments are required for TfNSW assets to assess their suitability for use of these vehicle types. The proponent is to contact TfNSW Special Permits Unit (see advisory note 7). The route assessment is to be revised based on the outcomes of the TfNSW bridge and culvert assessments.</p>	
	<p>The route study provided by ARES noted that the exact weights and dimensions of the Transformer are yet to be finalised, with guide dimensions offered. The maximum dimensions are to be provided in the updated route study.</p>	
	<p>Pinch point 17 demonstrates that to make the turn into Canalla Road from the Riverina Highway, the high-risk OSOM will be entering into the opposing lanes. This will require traffic to be stopped; however, sufficient detail on how this will occur is not provided. The updated information will need to clarify how long traffic will be stopped (TfNSW notes traffic cannot be stopped for more than 10 minutes). Please include this detail in the updated TIA and ensure any other locations where traffic is required to be stopped are provided.</p>	
	<p>The route study demonstrates that medians will be tracked over,</p>	



	<p>including at the intersection of the Newell Highway and Riverina Highway. See figure 1 within Attachment B. The proponent is to investigate whether the high-risk OSOM can avoid tracking over any medians or other infrastructure on the state road network.</p>	
	<p>Strategic concept designs will be required for works required along the state road network (for example, the median identified in e) that identify the scope of the works that would be necessary to ensure the asset could be made suitable for traversing (i.e pavement strengthening) or temporary removal.</p>	
	<p>Temporary changes to state road assets will need to include the length of time they will be affected, any interim treatments (e.g., line marking), and when and what will replace the asset post-completion of high-risk OSOM movement.</p>	
	<p>Signs are proposed to be removed at the Riverina Highway / Newell Highway. Details on any temporary signage and the timeframe for replacing traffic signs are to be included.</p>	
	<p>An extensive review of the high-risk OSOM routes regarding vertical and horizontal obstructions alignment, including existing formations, crossings, bridges, culverts, intersection roadside furniture, hazards, roundabouts, traffic signals, level crossings, existing</p>	



	<p>developments, signage and powerlines.</p>	
	<p>The route assessment does not include relevant TfNSW projects or other third-party projects that are currently under construction, or will be completed, on the State road network for the route. The route assessment must be updated to include mitigation measures or modifications required to navigate any identified road or rail projects along the routes (ie, Council works for Finley Main St project expected to commence in the financial year 25/26, see figure in Attachment B for location of works).</p>	
	<p>The pull-over bays and rest areas have been identified with swept paths; however, the diagrams provided aren't fully dimensioned as required. See advisory note 1 and 5.</p>	
	<p>Rail requirements are to be considered. See advisory note 9 and 10.</p>	



3. PROPOSED DEVELOPMENT

3.1 Overview of proposed development

The proposed development will involve the development, construction, operation and eventual decommissioning of a BESS with a capacity of 100 MW_{AC}/ 200 MWh connecting via underground TL directly to the existing Transgrid Finley 132/66 kV Substation).

The construction life of the Finley BESS is expected to be approximately 10 months (inclusive of pre-construction minor works), with a peak period of three months (5.5 days per week – Monday to Friday standard construction hours and half day on Saturday).

Construction of the Finley BESS would require light and heavy vehicles, plant, and equipment for the transportation of components and installation of the components on the development site. The development will require earth-moving equipment for civil and road works, cable trenching equipment, forklifts, and cranes, subject to detailed design to install the BESS and complete ancillary works. It is anticipated that the construction and commissioning phase will last approximately 10 months.

During peak construction, it is anticipated that approximately 55 full-time equivalent (FTE) jobs will be required. Employment numbers will fluctuate starting with about 15 workers on site for 1 to 2 months, then progressively increasing to 55 staff at about the 65% completion stage for several months before tailing off toward completion and the start of commissioning. About 5-10 staff are required for commissioning.

The construction is expected to commence in 2026. The workforce would be sourced from the local area where possible, and the wider region where worker deficits arise. It is expected the peak period would extend for approximately three months. Outside of this period, approximately 10-15 workers will be required at any one time.

The following standard construction hours are proposed for the Project:

- > Monday to Friday - 7 am to 6 pm;
- > Saturday – 8 am to 1 pm; and
- > Sunday and Public Holidays - No works to be undertaken.

No works are proposed to be undertaken outside of the standard construction hours. In the event this is required, Out of Hours (OOH) approval would be sought, and all works would be undertaken in accordance with the appropriate OOH protocols and approval processes.

The facility will self-operate 24 hours a day 7 days a week and only requires periodic maintenance by authorised staff. The operation of the facility will be monitored remotely. The facility is otherwise restricted to the public. Emergency response and maintenance activities may be required to be undertaken out of hours.

During operation, it is anticipated that approximately two (2) FTE jobs will be required.



3.1.1 STAGING AND TIMING OF DEVELOPMENT

The development will have three key traffic generating stages:

- > Minor pre-construction works and construction (duration of approximately 10 months);
- > Operation (duration of approximately 20-25 years); and
- > Decommissioning (decommissioned and the infrastructure removed following the End of Life (EOL) of the BESS - to be confirmed at a later stage but expected to be broadly consistent with construction, i.e., approximately 10 months)

3.1.2 SELECTION OF APPROPRIATE DESIGN VEHICLE

There would be one over-dimensional vehicle requiring escort round trip to and from the site delivering the transformer. The over-dimensional route assessment has been completed by Ares Group and is provided as a separate report.

Figure 11 - The largest vehicle anticipated to access the site (source: OSOM Route Study, Ares Group, 2025)

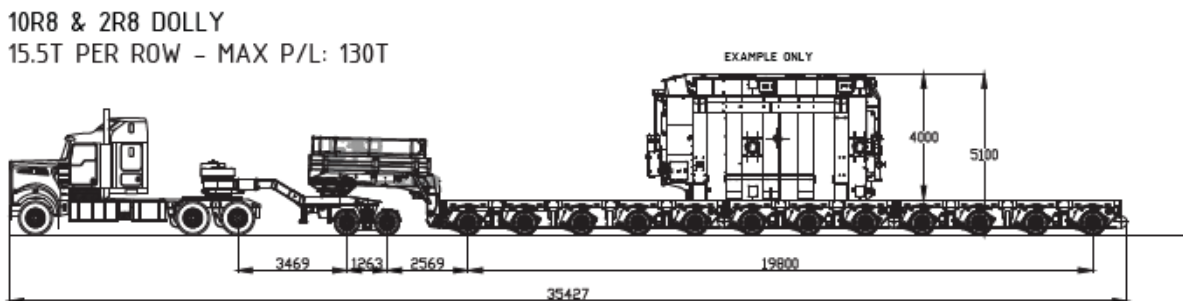

The load will be transported on a steerable platform trailer with dolly and hydraulic gooseneck. Overall dimensions are:

- > Length: 36m (excluding rear push truck)
- > Width: 4.2m
- > Height: 5.1m
- > Gross Combination Mass: 210 tons
- > Mass per Axle: 15.5 tons

The findings and recommendations of the OSOM Route Study are summarised in **Section 5 Heavy vehicle and OSOM routes**.

Excluding OSOM vehicle, the largest vehicles that will be utilised are Heavy Vehicles (12.5m to 20m HRV/AV), B-Doubles and Long Loaders.

3.2 Access

3.2.1 ACCESS LOCATION

Access to the site is from Riverina Highway via Canalla Road and Broockmanns Road, with entry/exit via three crossovers in total, one (1) located in Canalla Road and two (2) in Broockmanns Road.

All heavy vehicles will enter the via the proposed Canalla Road crossover.

A dedicated crossover will be constructed for Transgrid via Broockmanns Road in the west.

A dedicated crossover for light vehicles will be provided via Brockman Road in the east.





Detail of Intersection



- | | | |
|---|---|---|
| Legend | | |
| Development Site | ● Essential Energy Pole | Gate |
| ★ Primary Site Access (Heavy Vehicle) | ● Transgrid Pit | Fence |
| Lot | Proposed Development | Screening Vegetation |
| Road | Substation Switch Area | Proposed UG Connection line |
| Watercourse | Internal Road | ● Watertank |
| Existing Infrastructure | Temporary Facilities | ● CCTV Mast |
| Existing Substation | Car Parking | ● BESS Lighting Mast |
| Existing Easement | Laydown | |
| Essential Energy OH | Site Ofcs | |
| Essential Energy UG | BESS Substation | |
| Transgrid OH | BESS Buildings | |
| Transgrid Optic Fibre | Battery | |
| | Inverter | |



Figure 12
Proposed access points for light and heavy vehicles

Source: © State of NSW, Department of Customer Service, Spatial Services 2023
 Geospatial Development, 2023, Newmap 2023
 File: P001998_01_NWS18E2023_Proposed By: rmanh, Response Date: 1/07/2026

3.2.2 SIGHT AND STOPPING DISTANCE OF ACCESS LOCATION

3.2.2.1 Sight distance parameters

Premise has conducted a preliminary desktop analysis of the existing sight and stopping distances on Riverina Hwy / Canalla Rd and Broockmanns Rd / Canalla Rd intersections using aerial imagery. For purposes of this assessment, crossovers will be treated as intersection points. Furthermore, preliminary assessment was conducted on the proposed crossovers to Canalla Road and Broockmanns Road.

Austrroads Guide to Road Design – Part 3 (AGtRD3) Geometric Design and Part 4A (AGtRD4A): Unsignalised and Signalised Intersections outline the requirements for sight distance for unsignalised intersections. The following three parameters are crucial:

- > Safe Intersection Sight Distance (SISD) - SISD is the minimum sight distance that should be provided on the major road at an intersection. This sight distance enables vehicles approaching on the major road to spot a vehicle on a minor road at the holding line.

Figure 13 - Assessing SISD (source AGtRD4A 2023)

Figure 3.2: Safe intersection sight distance (SISD)

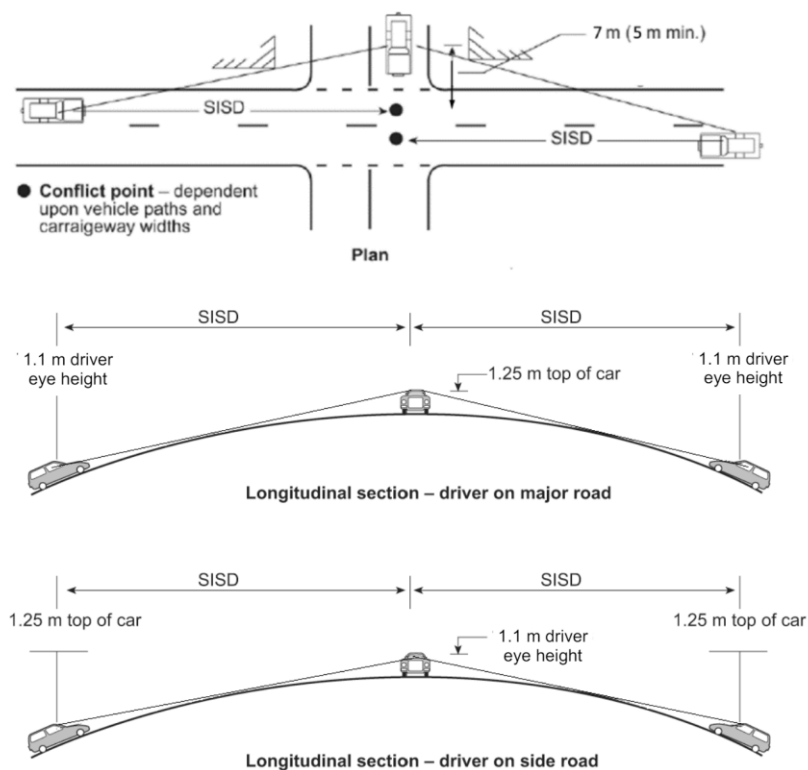

- > Safe Stopping Distance (SSD) – is the distance to enable a normally alert driver, travelling at the design speed on wet pavement, to perceive, react and brake to a stop before reaching a hazard on the road ahead.

Figure 14 – Car stopping sight distance

Figure 5.2: Car stopping sight distance

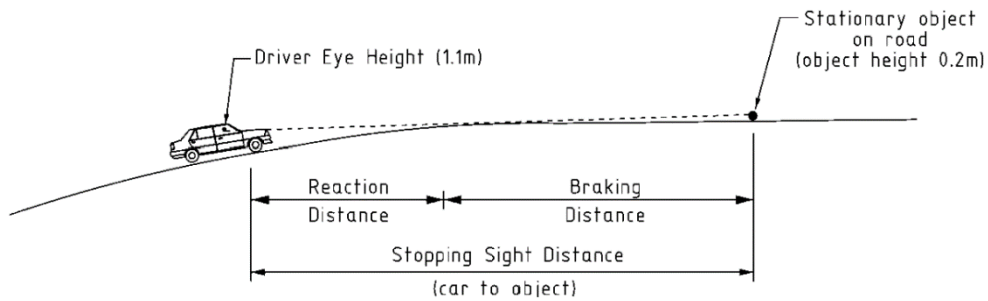
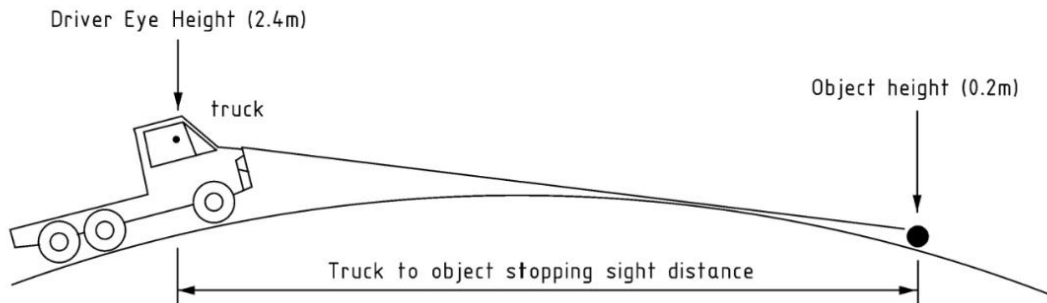
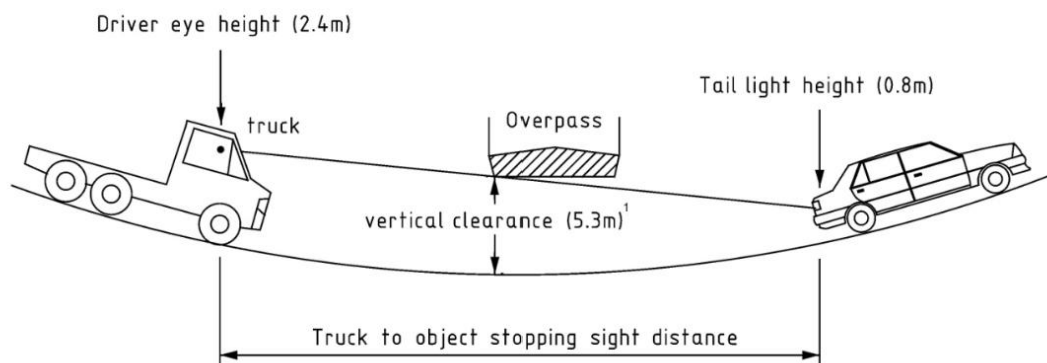

Figure 15 - Assessing SSD (source AGtRD3 2021)

Crest



Sag



- > Approach Sight Distance (ASD) - the minimum level of sight distance that must be available on the minor road approaches to all intersections to ensure that drivers are aware of the presence of an intersection.

Figure 16 - Assessing ASD (source AGtRD4A 2023)

Figure 3.1: Application of approach sight distance (ASD)

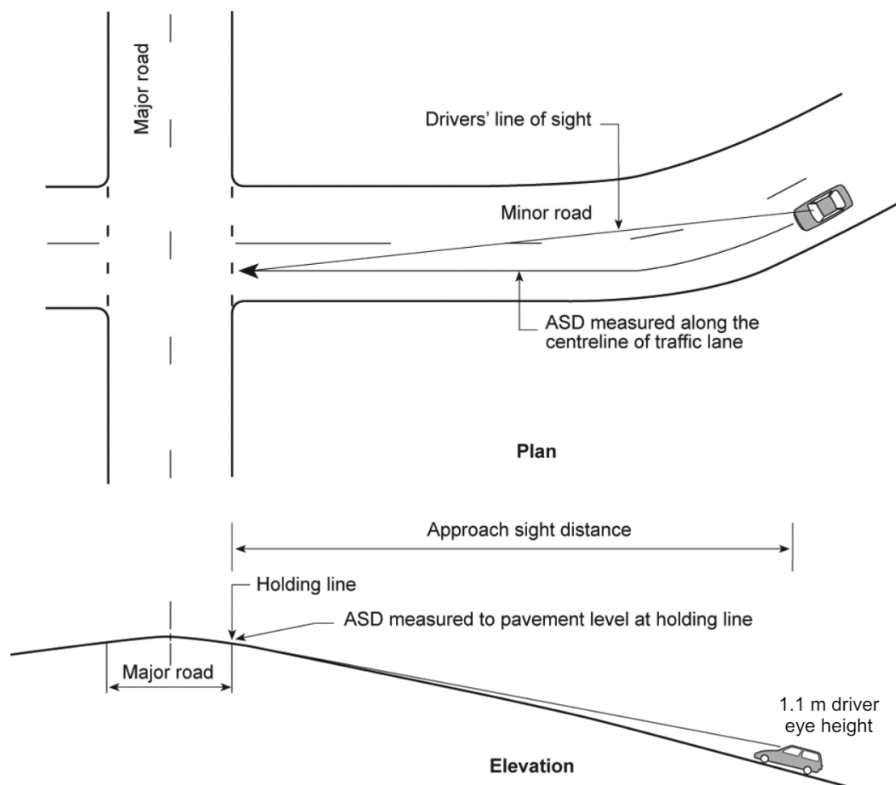

The guide recommends that the Safe Intersection Sight Distance (SISD) should be the minimum sight distance provided on the Major Road at any intersection.

The Austroads guide provides a formula for calculating SISD values for vehicles at varying design speeds and road conditions. The following formula is used to determine the SISD for heavy vehicles:

Figure 17 - Sight Distance Equation

$$SSD/ASD = \frac{R_t \times V}{3.6} + \frac{V^2}{254x(d + 0.01 \times a)} \qquad SISD = \frac{D^t \times V}{3.6} + \frac{v^2}{254 + (d + 0.01 \times a)}$$

- > ASD – Approach Sight Distance (m)
- > SSD – Safe Stopping Distance (m)
- > Rt – Reaction time (seconds – 2.0 / 2.5) – given the road conditions, minimum reaction times are not appropriate

Note: requirements for both values will be considered

- > V – 85th percentile operating speed (km/h)

Note: at present, data on operating speed is not available; therefore, the design speed will be used as the operating speed.

- > D – coefficient of deceleration (Heavy Vehicles - 0.24/0.29; passenger vehicles – 0.36)

General tables suggest the value of 0.29 should be used for trucks; while the Austroads Guide to Road Design Part 4A suggests that a value of 0.24 should be used for check cases.

- > a – longitudinal grade in %
Note: the terrain will be reviewed via Google Earth in absence of survey.
- > SISD – Safe Intersection Sight Distance (m)
- > Dt – Decision time (s) = observation time (3s) + reaction time (2.0 / 2.5s)

3.2.2.2 Local Sight Distance Assessment

Using Google Earth Pro, we assessed the road grades to ascertain the requirements for sight distances. The grades are shown in **Table 8**. Based on the average grades on a 300m long approach to the conflict points, the key roads, in approach to the site access points can be considered flat.

Table 8 - Local Road Grades and Speed Limits

	Riverina Highway eastbound	Riverina Highway westbound	Canalla Road north of Brockmanns Road	Brockmanns Road east of Canalla Road	Crossovers to Brockmanns Road and Canalla Road
a=grade (%)	0.5%	0.4%	0.5%	0.3%	0.0%
Speed Limit / Design Speed	100km/h (110km/h)	100km/h (110km/h)	100km/h (110km/h)	100km/h (110km/h)	20km/h (30km/h) *

In the absence of data on operational speed on key roads, we will rely on the design speed (derived from sign-posted speed). The proposed crossovers speed limit and the design speed were assumed based on the geometry and use of the site. **Table 9** shows the requirements and availability of key sight distance parameters.

Table 9 - Local Sight Distance Requirements

Road Name	Speed limit (Design Speed)	Reaction time (s)	SISD (m)	SSD/ASD (m)
Riverina Highway (eastbound)	100mk/h (110km/h)	2.0	314.26	222.60
		2.5	329.54	237.87
Riverina Highway (westbound)	100mk/h (110km/h)	2.0	314.81	223.14
		2.5	330.09	238.42
Broockmanns Road	100mk/h (110km/h)	2.0	315.36	223.70
		2.5	330.64	238.98



Road Name	Speed limit (Design Speed)	Reaction time (s)	SISD (m)	SSD/ASD (m)
Canalla Road	100mk/h (110km/h)	2.0	314.26	222.60
		2.5	329.54	237.87
Crossovers	20km/h (30km/h) *	2.0	-	29.60
		2.5	-	33.77

Preliminary desktop assessment suggests that all of the sight distance parameters (SISD/SSD/ASD) are satisfied, and the proposed crossovers can be designed to achieve necessary sight distances.

3.2.3 SERVICE VEHICLE ACCESS

During their inbound journey, all heavy vehicles will travel along Hume Motorway (M31), Goulburn Valley Freeway (M39, A39) and Newell Highway (A39). The final segment of the route requires transversal of a few local roads, turning left onto Canalla Road (via Riverina Highway) and left into the development site.

A crane will be required on site. The nominated 20t Franna crane can typically be driven to the construction site under its own power, as it meets standard road transport dimensions, provided axle loads comply with legal limits. The crane's dimensions (9.76m L x 2.50m W x 3.07m H) fall within legal limits for road travel without requiring an Oversize Overmass (OSOM) permit. Although the crane can drive on roads, in cases where long-distance transport or permit restrictions apply, it may be moved on a low-loader (float trailer).

3.3 Circulation

Circulation refers to the internal traffic management strategies implemented to promote the safe and efficient movement of traffic within the site. Internal traffic management may generally involve the use of signage, bollards, line marking or physical barriers to reduce traffic conflicts and ensure smooth traffic flow within the site. The internal traffic management for the site is to be designed to accommodate the largest vehicle anticipated to use the site.

3.3.1 PROPOSED PATTERN OF CIRCULATION

Internal roadways are designed in a way that all vehicles can enter the study area with sufficient room to turn around and drive out in a forward direction with two crossovers on to Broockmanns Road or to Canalla Road.

3.3.2 INTERNAL TRACK WIDTHS

Internal tracks have been designed for a minimum road width of 6m to allow for easy passing of heavy vehicles if required.

3.3.3 SERVICE AREA LAYOUT

The service area for the proposed BESS will be dependent on the operational requirements of the BESS. It is anticipated that the internal circulation road will be sufficient to accommodate all movements.



3.4 Parking

3.4.1 PARKING REQUIREMENTS

It is understood that peak traffic generation would occur during the construction phase of the project with a maximum of approximately 55 staff onsite. There is sufficient room within the development site to accommodate informal parking for construction workers.

Local contractors are likely to drive to the site while specialist out of region contractors accommodated locally are likely to be bussed to site.

It is anticipated the BESS will have a total workforce of 2 FTE in the operational stage, with workers driving to site in their own vehicle. The size and configuration of parking spaces should be provided depending on expected vehicle size to be accommodated.

3.4.2 PROPOSED PARKING SUPPLY LAYOUT

Any temporary parking and set-down areas required during construction will be reinstated and landscaped once the BESS is operational; and the proposed BESS will be managed remotely once operational, requiring minimal site attendance from maintenance staff therefore they are expected to parking within the internal circulation areas.



4. IMPACT OF PROPOSED DEVELOPMENT

4.1 Trip Generation

The preferred hierarchy of data sources for traffic generation rates is:

- Traffic generation survey of an existing development similar to the proposed development in terms of its land use, scale, location, etc.

Guide to Transport Impact Assessment TS 00085 (2024) which supersedes the Guide to Traffic Generating Developments (GTGD 2002) and Updated Traffic Surveys Technical Direction (TDT 2013/04a).

First principles assessment preferably based on forecast usage data.

As there are no available traffic surveys of similar developments and the above referenced documents do not sufficiently cover similar developments, first principles have been adopted based on forecasted rates and worker numbers on the site.

4.1.1 AVERAGE ANNUAL DAILY TRAFFIC (AADT)

The traffic assessment considers the upper limit of daily trips for each vehicle type, as outlined below. These figures represent the maximum anticipated traffic volumes but do not necessarily reflect the actual number of trips per day, as workforce numbers and vehicle movements will vary depending on the project stage.

Table 10 - Heavy vehicle movements

Vehicle Type	Anticipated Trips	Anticipated Loads
OSOM Load	1 movement (2 trips) during entire project.	Transformer
Heavy – 12.5m to 20m HRV/Six Axle B-Double	Up to 45 movements (90 trips) per day	Water trucks Containers Construction Material Construction Mobilisation
Long Loaders	Up to 5 movements (10 trips) per day	Culvert Material Excavator Bulldozer Grader Compactor Piling Rig



Table 11 - Workforce movements

Vehicle Type	Anticipated Trips	Anticipated Loads
Private Vehicle (car/ute) – 2 pax onboard	1.5 persons per ute per day up to 2 trips per ute (assumption half workers carpool and half don't)	Local contractors are likely to drive to the site. 1-2 persons per vehicle. Anticipated 56% of work force to be local.
External contractors, auditors, visitors etc.	1-2 persons per passenger vehicle; likely to arrive and depart development site outside of peak times.	Assumed up to 10 movement per day during peak construction period.
Bus – 22-seater bus (19 pax onboard)	Up to 2 bus trips per day in Months 1,2,3,4,10 and 11. Up to 4 bus trips per day in months 5,6,7,8,9.	Specialist out of region contractors likely to be bussed to site. Assumed that bus is up to 60% occupied.

Table 12 - Workforce monthly breakdown

Month	1	2	3	4	5	6	7	8	9	10	11
Onsite Total Persons	5	15	22	32	50	52	52	38	34	9	4
Specialist – HSE/QA/Electrical/Grid (Specialty workers likely from outside of the region)	3	9	12	15	32	34	41	29	32	9	4
Civil/Mechanical – (Local Contractors May Be Possible)	2	6	10	17	18	18	11	7	2	0	0

Quantity of daily vehicular trips is estimated on following assumptions:

- > The adopted daily traffic volumes are considered to be the maximum possible traffic attracted to the development site during the peak construction phase with the following breakdown:
 - Heavy vehicles (GAV and B-Doubles)– 45 movements (90 trips)
 - Long loaders – 5 movements (10 trips)



- Buses – 4 movements (8 trips) – assuming buses are parked on the development site when not in use.
 - Light vehicles workforce – 18 movements (36 trips)
 - Light vehicles – contractors, auditors and inducted visitors – 10 movements (20 trips)
 - Escorted OSOM movement is excluded from the calculations as it would only occur on one day during the entire project life.
- > The Finley BESS will have a total workforce of two in the operational stage, with each worker driving to site in their own vehicle for a total of 2 vehicles/day.
 - > Each vehicle is expected to make two vehicle trips, once in when arriving at the start of the day and once when leaving the site at the end of the day. The exception is to this are a small number of light vehicles which may make two return trips per day. This is not likely to happen within the same hour.
 - > A distribution of 50% inbound and 50% outbound traffic has been adopted for all trips.
 - > The AADT for the proposed site is summarised in **Table 13**.

Table 13 – AADT Generation for Proposed BESS

	Total	Light Vehicles	BUS	Heavy Vehicles+ long loaders
Construction AADT (Veh/d)	164	56	8	100
Operation AADT (Veh/d)	4	4	0	0

4.1.2 PEAK HOUR

Peak hour during construction will occur when some of the delivery arrivals or departures coincide with the site personnel arriving or departing during construction, noting this would be less common as delivery vehicles would be unlikely to be scheduled for arrival when they are no construction workers on site to enable entry and unload. Peak hour is assessed for a maximum number of vehicles accessing the site, which is deemed to be period when workers arrive or depart the site. Peak traffic trip generation was estimated on following assumptions:

- > Overall development site peak traffic trips (general peak) account for 20% of the development site total daily traffic trips;
- > Overall development site peak traffic hours will not coincide with the recorded network peak hours. Recorded AM peak hour on Riverina Highway is 09:00-10:00 while general AM peak is expected to occur in period 06:30-07:30. Recorded PM peak hour on Riverina Highway occurs in period 15:15-16:15 while general PM peak is expected to occur between 17:00-18:00.
- > Peak traffic hour for heavy vehicles (HV peak) is likely to occur during work hours, outside of general peak hours and outside of network peak hours. Maximum 10 heavy vehicle movements are expected during HV peak, generating in total 20 trips.



- > It is assumed that both AM and PM peaks have the same quantity of vehicle movements, but generally reversed directions.

Peak hour traffic during operational phase is estimated to occur when workers arrive or leave the site for maintenance purposes during operation.

The estimated peak hour vehicle movements generated from the proposed BESS during construction and operational phase is summarised in **Table 14** and **Table 15**.

Table 14 – Cumulative Peak Hour Trip Generation for Proposed BESS during construction

	Total	Light Vehicles	BUS	Heavy Vehicles+ RAV
Peak (Veh/hr)	33	19	4	10

Table 15 – Peak Hour Trip Generation for Proposed BESS during operation

	Total	Light Vehicles	Heavy Vehicles
Peak (Veh/hr)	2	2	0

4.1.3 DAILY AND SEASONAL FACTORS

It is not expected that any daily or seasonal factors will affect the maximum peak hour traffic generated from the site. Supply of the batteries will fluctuate depending on container arrival to the port due to local and regional conditions, resulting in fluctuations in daily traffic volumes only.

4.1.4 PEDESTRIAN GENERATION AND MOVEMENTS

Given the location and extent of the proposed BESS, there are no additional pedestrian movements anticipated around or near the site.

4.1.5 PRE-CONSTRUCTION MINOR WORKS

Pre-construction minor works are considered to be a separate construction phase by TfNSW. Therefore, a complete assessment of potential transport impacts and mitigation measures are required for this phase. Based on the Department of Planning, Housing and Infrastructure (DPHI)'s definition, pre-construction minor works may include:

- Surveys;
- Overhead line safety marking;
- Building and road dilapidation surveys;
- Investigative drilling, excavation or salvage and geotechnical investigation works;
- Minor clearing or translocation of native vegetation;
- Establishing temporary site office (in locations meeting the criteria identified in the conditions of consent);



- Installation of environmental impact mitigation measures, fencing enabling works;
- Temporary wind monitoring masts;
- Construction of minor access roads and minor adjustments to services and utilities

It is expected that during the period of pre-construction minor works, traffic volumes shall not exceed the peak volumes during main construction works specified in **Section 4.1.2**. No OSOM vehicle movements are proposed, and no temporary traffic controls will be implemented at the intersections unless otherwise agreed by TfNSW.

All mitigation measures that are mentioned in this TIA will also be applicable to pre-construction minor works. In particular, all proposed road and intersection upgrades, including at the proposed site access at Riverina Highway to Canalla Road Broockmanns Road will be completed concurrently with pre-construction minor works. Based on our experience with similar developments, this will also be enforced via the conditions of consent established by the DPHI.

4.2 Traffic distribution

4.2.1 HOURLY DISTRIBUTION OF TRIPS

The hourly distribution of trips has been adopted as per the information provided in **Section 4.1.1**.

Peak hour will occur when the maximum loader capacity coincides with the site personnel arriving or departing during construction.

During operation peak hour traffic is estimated to occur when workers arrive or leave the site for maintenance purposes for a maximum of two (2) movements. It is unlikely there would be daily maintenance work onsite however, for the purposes of the analysing the traffic impact, worst case scenario is assessed.

4.2.2 TRIP DISTRIBUTION

- > All heavy vehicles will access the site turning left onto Canalla Road (via Riverina Highway) and left into the site.
- > Light vehicles distribution is expected to be as follows:
 - 20% eastbound from Riverina Highway – Canalla Road
 - 60% westbound from Riverina Highway – Canalla Road
 - 20% eastbound from Broockmanns Road
- > It is assumed that construction workers will either reside or will be accommodated in the local area, with the majority staying in Finley. Workers may also arrive from Deniliquin. To be conservative it has been assumed that contractors will arrive by buses with a 50% distribution along Riverina Highway.

Based on the assumed traffic distribution described above the total traffic movements to and from the site at the intersection of Riverina Highway, Canalla Road and Marantellis Road has been determined in **Table 16**.

Table 16 – Distribution of development-site-generated general peak hour traffic at the intersection of Riverina Highway, Canalla Road and Marantellis Road

	Right In			Left In			Right out			Left Out		
	LV	BUS	HV	LV	BUS	HV	LV	BUS	HV	LV	BUS	HV
AM Peak	3	0	1	9	2	5	0	2	3	0	0	1
PM Peak	0	0	1	0	2	3	3	0	1	9	2	5

4.3 Impact of generated traffic

The impact of the additional traffic generated from the proposed Finley BESS has been analysed and split into three sections; the impact on traffic safety, the impact of additional traffic on key roads and the impact of additional traffic on the intersection of Riverina Highway, Canalla Road and Marantellis Road.

4.3.1 IMPACT ON TRAFFIC SAFETY

From a traffic safety perspective, surrounding roads are currently operating in a manner consistent with other rural roads in the area. The existing local roads utilised by the development site traffic have the required sight distances and will be sufficient to accommodate heavy vehicles.

Turn warrant assessments were undertaken for the intersection between Riverina Highway & Canalla Road based on warrants contained in Austroads’ “Guide to Traffic Management Part 6: Intersections, Interchanges and Crossings” (AGTM6). The assessment is based on a design speed of 110km/h, being 10km/h above the posted speed limit along with estimated traffic volumes.

Table 17 - AM peak turning volumes

	Q _M	Q _R / Q _L	Required Treatment
Right	152	5	BAR
Left	76	17	BAL



Figure 18 – Major Road Turn Warrants – Right and Left Turn – AM peak

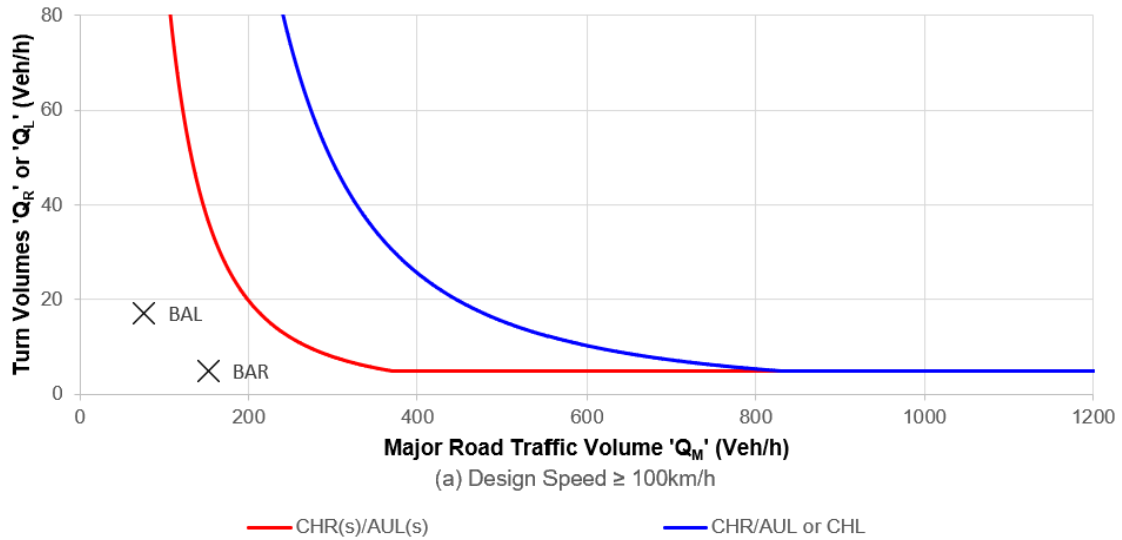

The turn treatment warrants assessment uses peak hour data for Wednesday (19 February 2025) collected by Matrix and is based on the unlikely event when the network AM peak hour coincides with development construction peak for the worst-case scenario.

Table 18 - PM Peak turning volumes

	Q _M	Q _R / Q _L	Required Treatment
Right	138	3	BAR
Left	79	6	BAL

Figure 19 Major Road Turn Warrants – Right and Left Turn – PM peak

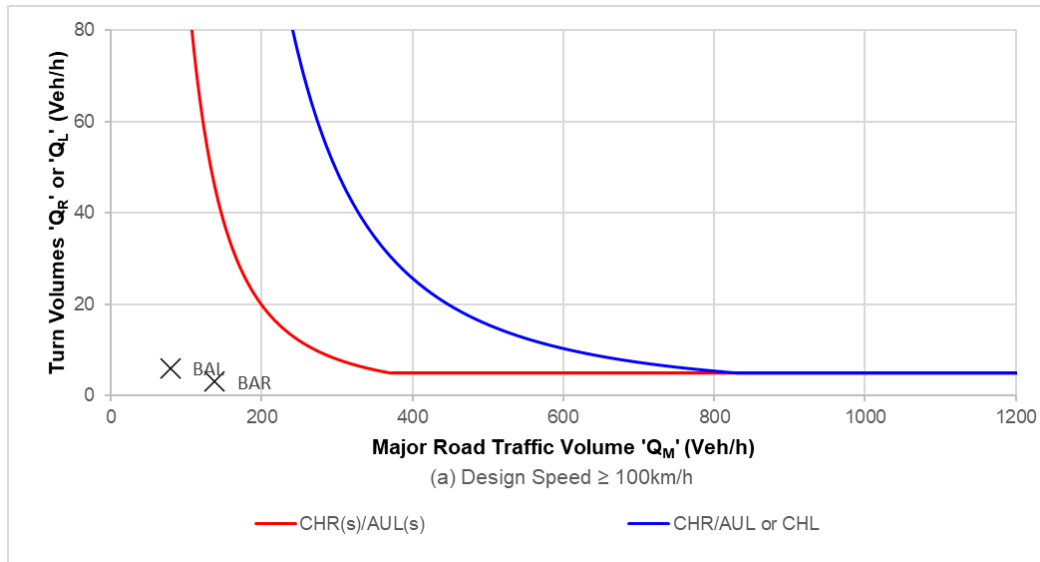

The turn treatment warrants assessment for pm peak is also based on the unlikely event when the network PM peak hour coincides with development construction peak for the worst-case scenario.

The adequate treatment for the expected level of traffic is BAR/BAL.

Currently the Riverina Highway, Canalla Road and Marantellis Road intersection features an 85m left turn deceleration lane on to Canalla Road and a 75m left turn deceleration lane on to Marantellis Road and therefore exceeds the minimum BAR/BAL standard.

Sensitivity testing confirmed that the current configuration can tolerate up to 20 trips turning right and 60 trips turning left from Riverina Highway within BAR/BAL standard, clearly demonstrating there is sufficient capacity at this intersection to accommodate construction works for Finely BESS.

It is not anticipated there will be any additional impact on traffic safety through the increase of BESS traffic using the existing intersection of Riverina Highway and Canalla Road, given that anticipated BESS peak traffic generation hours will not coincide with peak hours on Riverina Highway.

The intersection will be upgraded to bring the existing geometry to compliance with the current BAL/BAR standards.

4.3.2 IMPACT OF ANTICIPATED TRAFFIC ON KEY ROADS

A comparison of the AADT and peak hour traffic volumes on Riverina Highway for the 2026 existing conditions, 2026 development construction conditions and 2027 post development construction conditions are provided in **Table 19**. A growth rate of 1% has been used for annual increase of passing traffic.

Table 19 – Comparison of Riverina Highway traffic volumes and net increase in trips

Road		2026 'No Development' traffic volume	2026 During Development Construction traffic volume	Net increase	2027 Post Development traffic volume	Net increase
Riverina Highway	AADT	1,752 trips/day	1,916 trips/day	9.4%	1,756 trips/day	0.2%
	AM peak hour	111 trips/hour	144 trips/hour	29.7%	113 trips/hour	1.8%
	PM peak hour	119 trips/hour	152 trips/hour	27.7%	121 trips/hour	1.7%

The proposed Finley BESS would result in a percentage increase in traffic volumes ranging from 9.4% (AADT on Riverina Highway) to 29.7% (AM peak hour on Riverina Highway) during construction.

After the construction works, the total net increase during operation would range from 0.2% (AADT on Riverina Highway) to 1.8% (AM peak hour on Riverina Highway) during construction.

The percentage increase in traffic volume during operational stage is not considered significant. While the increase in vehicular trips during construction stage can be considered significant, SIDRA Intersection modelling clearly shows there is significant spare capacity at this intersection.

The net increase in daily traffic volume and peak hour volume generated by the proposed Finley BESS would be easily absorbed into the surrounding road network with minimal impact on the capacity of the existing traffic streams using the road system.

4.3.3 POST 10 YEAR TRAFFIC FLOW

TfNSW generally requires an assessment to be carried out to determine if there are any impacts from proposed developments for a + 10 years post development scenario.

Existing traffic volumes on roads are expected to increase over time and for a road such as Riverina Highway, the natural growth of the traffic volume is expected to be low and in the order of 1% per annum.

On this basis, the existing AADT on Riverina Highway would grow over 10 years from the existing 1,734 trips/day to 1,916 trips/day. The existing peak hour traffic would grow from 110 trips/hr to 121 trips/hr in the morning peak and from 118 trips/hr to 130 trips/hr in the evening peak.

Whilst the traffic volumes on the surrounding roads may increase over time, the overall traffic from the Finley BESS is not likely to change. Therefore, the relative potential impact of the transport of product from the Finley BESS would decrease over time.



4.3.4 IMPACT OF EXPECTED TRAFFIC ON KEY INTERSECTIONS

4.3.4.1 SIDRA methodology

4.3.4.1.1 Input Data

Traffic data showed that peak hours on Riverina Highway occur in the periods 08:00-10:00 and 15:00-17:00 depending on the day.

The anticipated AM peak development hours are likely to occur prior to the network peak, while PM peak hours may partially coincide with the network peak. In this instance, AM peak is deemed the critical peak as vehicles are predominantly turning from Riverina Highway onto Canalla Road as construction staff arrive to work.

While traffic flow in **Section 2.6.1.2** was assessed using average values across the surveyed days, Wednesday data was used for the SIDRA analysis as the peak traffic flow was the highest out of all surveyed days.

The peak traffic flow on Wednesday was recorded at 09:00-10:00 for AM peak and at 15:15-16:15 for PM peak. These volumes were used for modelling, although the development peak traffic will not coincide with these times for added conservatism (06:30-07:30 time period that coincides with anticipated Finley BESS general peak traffic saw approximately 50% of recorded AM peak traffic).

4.3.4.1.2 Modelling Settings

The modelling was completed using Design Life setting for following reasons:

- > This setting allows easier assessments of different horizon years; and
- > This setting reduces the risk of manual error where on-field data is key input data and the projected traffic growth is calculated by the software for any given growth rate.

4.3.4.1.3 User Classes

The model differentiates several classes:

- > LV (default) – passing traffic – Austroads Class 1;
- > HV (default) – passing traffic – Austroads Class 2-5;
- > AV (U2) - passing traffic – Austroads Class 6-9;
- > RAV (U3) - passing traffic – Austroads Class 10 + OSOM;
- > B – Buses;
- > dL (U4) – Development LV Traffic; and
- > dH (U5) – Development HV+RAV traffic.

The following parameters were used for each class:



Table 20 - Parameters For User Classes - SIDRA model

Class	PCU	Mass	Maximum Power	Vehicle Length	Queue Space
LV	1	1,600kg	120kW	4.85m	7.35m
HV	2	35,000kg	160kW	12.5m	15.0m
B	1.65	35,000kg	160kW	10.0m	13.0m
AV	3	64,000kg	350kW	20.0m	22.0m
RAV	4	92,500kg	410kW	26.0m	28.0m
U4	1	1,600kg	120kW	4.85m	7.35m
U5	2.5	38,000kg	300kW	22.0m	25.0m

Note: Parameters were used or interpolated in accordance with Operational Modelling Guidelines, prepared by MRWA in 2021.

4.3.4.1.4 Interpretation of Results

Table 21 shows the thresholds for determining the Level of Service (LOS) for different type of intersections based on delays and based on flow/capacity ratio (Degree of Saturation).

Table 21 - Level of Service thresholds (SIDRA Models)

Level of Service for $v/c \leq 1.0$	Average delay per vehicle in seconds (d)			Level of Service for $v/c > 1.0$
	Signals	"SIDRA Roundabout LOS" method (1)	Sign Control (Default for roundabouts) (1)	All Intersection Types
A	$d \leq 10$	$d \leq 10$	$d \leq 10$	F
B	$10 < d \leq 20$	$10 < d \leq 20$	$10 < d \leq 15$	F
C	$20 < d \leq 35$	$20 < d \leq 35$	$15 < d \leq 25$	F
D	$35 < d \leq 55$	$35 < d \leq 50$	$25 < d \leq 35$	F
E	$55 < d \leq 80$	$50 < d \leq 70$	$35 < d \leq 50$	F
F	$80 < d$	$70 < d$	$50 < d$	F

4.3.4.2 Intersection analysis

Intersection analysis has been undertaken at the intersection of Riverina Highway, Canalla Road and Marantellis Road for the 2026 construction traffic and 2036 post development traffic volumes. The surveyed existing traffic volumes 2025 have been increased with a 1% annual growth rate to 2026 (the year of construction) and 2036 using a compound growth model for the final years.

Figure 20 - SIDRA Model Geometry

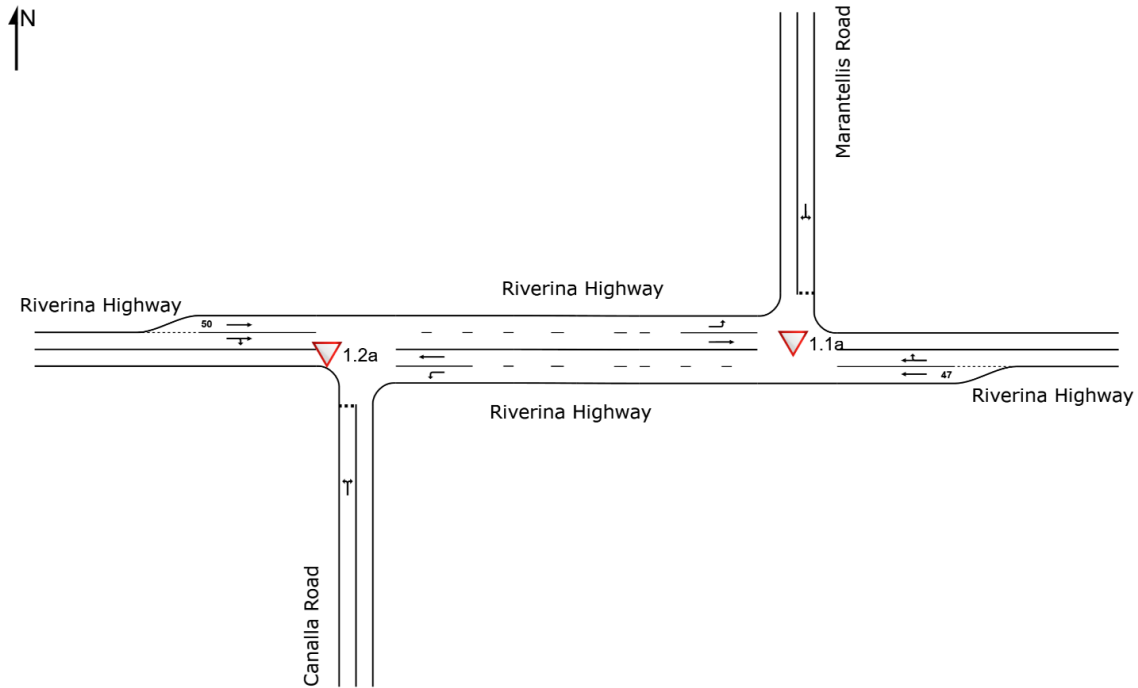

Figure 21 - SIDRA Model 2026 AM (Development Construction) – Movement flows

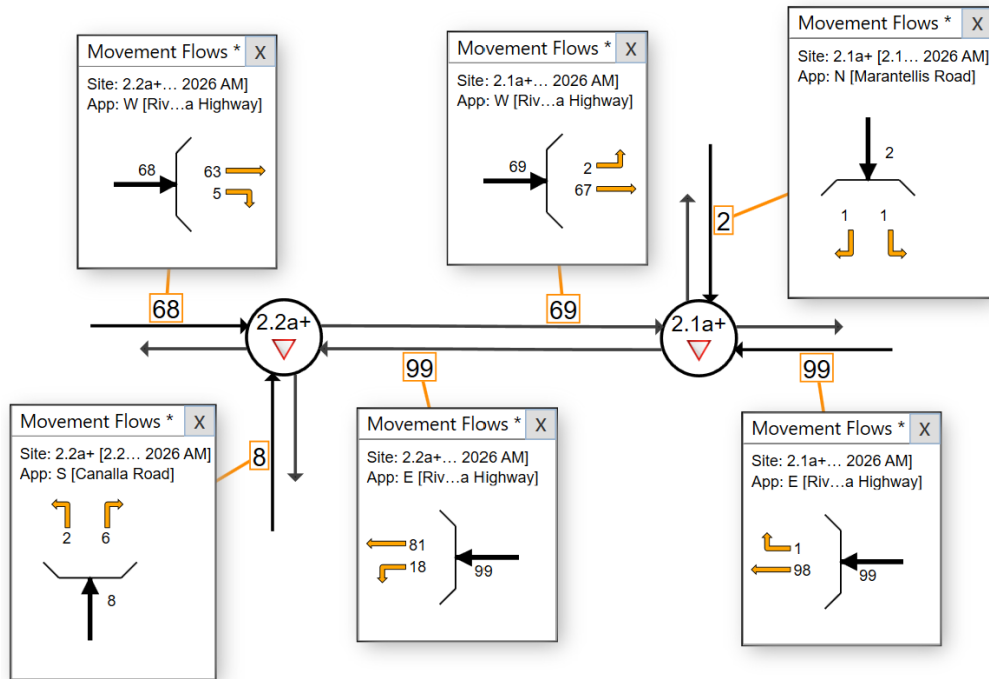

Figure 22 - SIDRA Model 2026 AM (Development Construction) – DoS

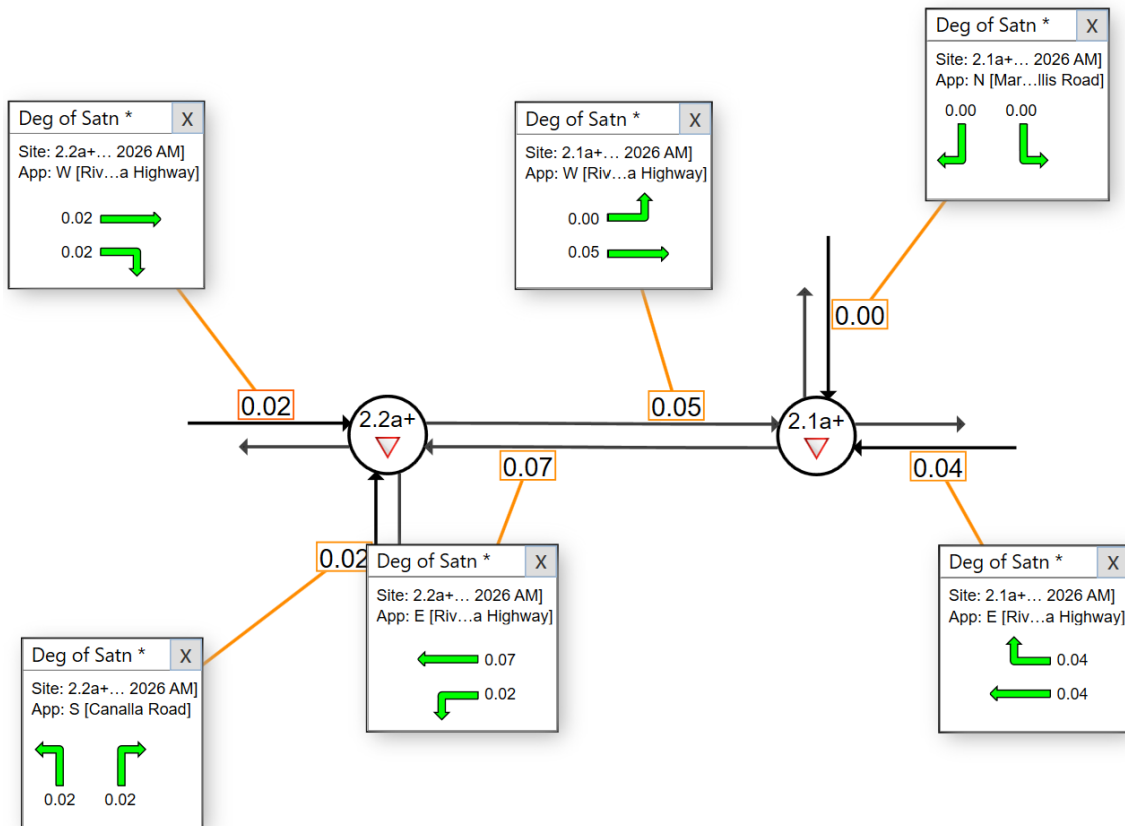

Figure 23 - SIDRA Model 2026 PM (Development Construction) – Movement flows

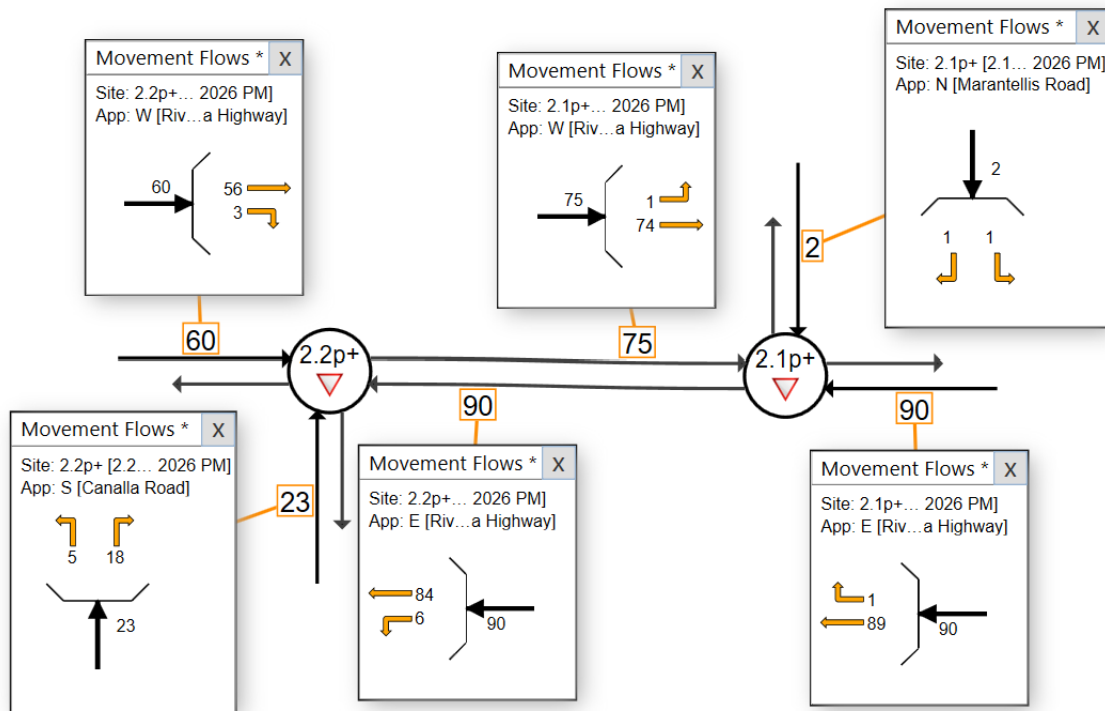

Figure 24 - SIDRA Model 2026 PM (Development Construction) – DoS

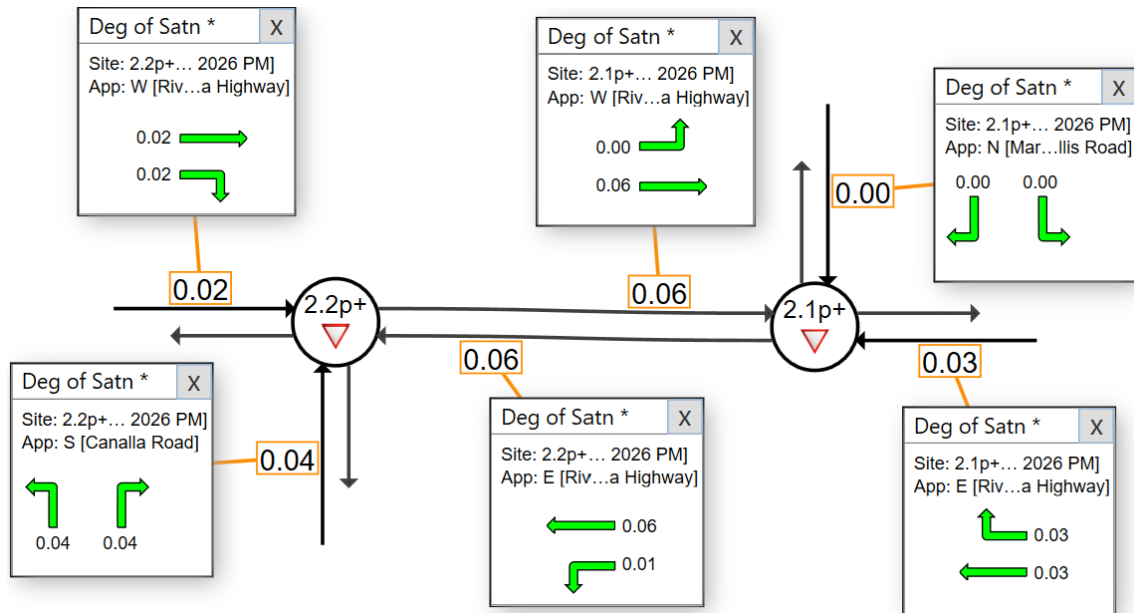

Figure 25 - SIDRA Model 2036 AM (Post Development) – DoS

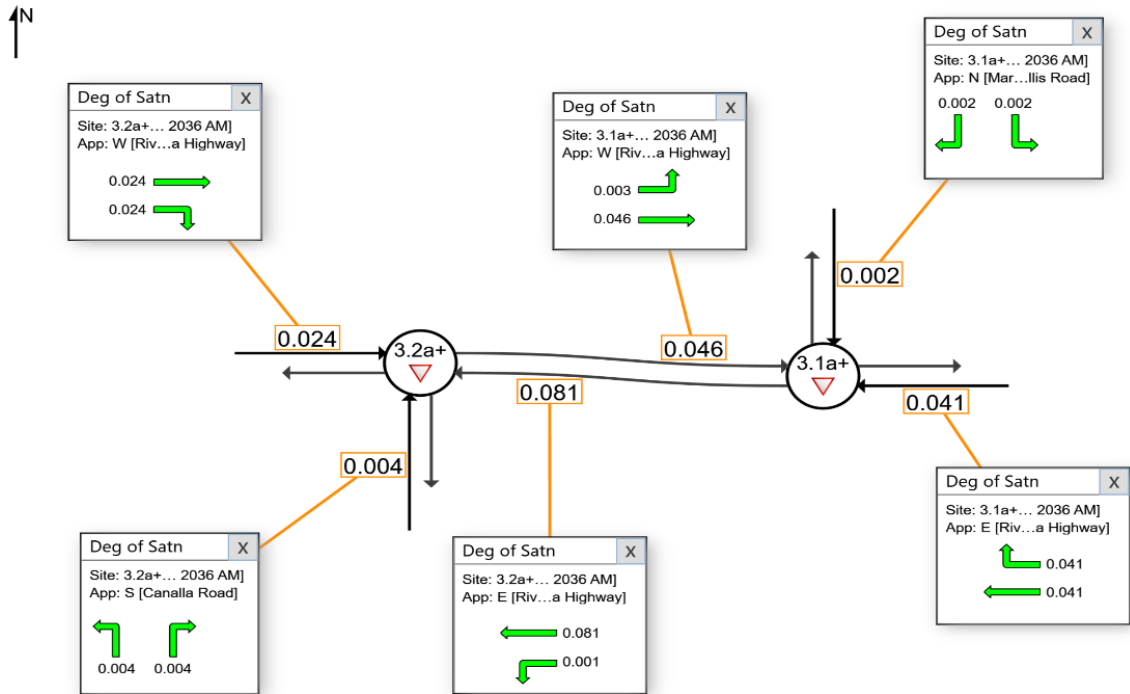

Figure 26 - SIDRA Model 2036 PM (Post Development) – DoS

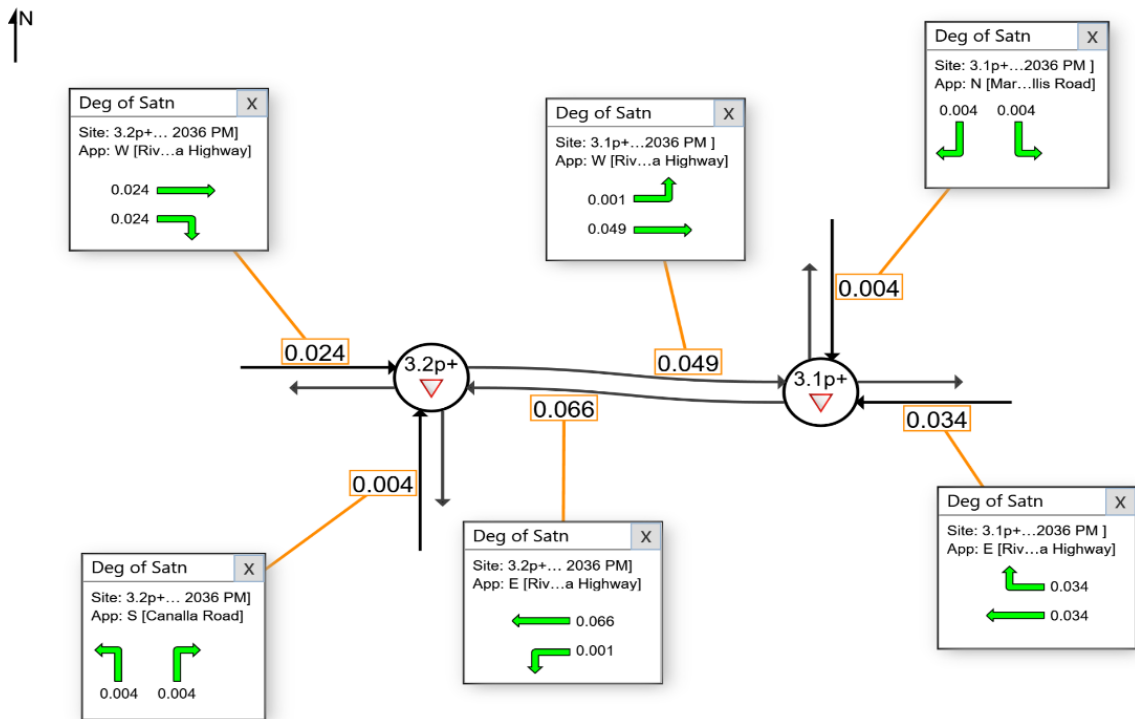
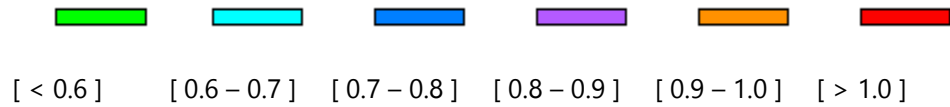

Table 22 - Colour code based on Degree of Saturation



Appendix B shows the SIDRA output results for the above network models. The results are summarised below:

- > 2026 Construction Traffic model:
 - The overall degree of saturation (DoS) for the network is 0.073 for the AM and 0.060 for the PM Peak Hour.
 - The maximum control delay for the worst movement is 16.2 seconds, which is for the Canalla Road approach right turn during the AM peak.
 - No queuing is anticipated for either the AM or PM peak.
 - The level of service for each leg of the intersection is Level of Service A for both the AM and PM peak hour.
- > 2036 Post Construction Traffic model
 - The overall degree of saturation (DoS) for the network is 0.081 for the AM and 0.066 for the PM Peak Hour.
 - The maximum control delay for the worst movement is 8.2 seconds, which is for the Marantellis Road approach right turn during the PM peak.
 - There is no predicted queue distance for either the AM or PM peak.
 - The level of service for each leg of the intersection is Level of Service A for both the AM and PM peak hour.

4.3.5 IMPACT OF OTHER PROPOSED DEVELOPMENTS IN VICINITY

As mentioned above in **Section 2.10**, the following developments in the vicinity of the development site are in the planning system at the time of writing this report:

- > South Coree Battery Energy Storage System (100MW / 400MWh)- Broockmanns Road, Finley - Current Status: Prepare EIS > data currently unavailable, however directly impacting the immediate network.
- > Berrigan Battery Energy Storage System (BESS) (400MW / 1600MWh) - Riverina Highway, Finley - Current Status: Prepare EIS > data currently unavailable, however directly impacting the immediate network.
- > Tocumwal Magazine Storage Upgrade - 431 Newell Highway – 14 vehicle trips in the peak hours as per TIA prepared by GHD in July 2024 – unlikely to impact immediate network.

Tocumwal Magazine Storage Upgrade is unlikely to have a traffic impact on the immediate network; however, Berrigan BESS and South Coree BESS construction traffic will likely access the respective development sites via the similar routes as Finley BESS. At present there is no evidence these projects will be in construction concurrently as EIS is underway; however, should they be constructed concurrently, the



intersection would need to be assessed to account for the cumulative impact. Assessment of Finley BESS shows there is ample spare capacity at Riverina Highway / Canalla Road intersection.

4.4 Assessment of Traffic Noise

The NSW Road Noise Policy, prepared by the Department of Environment, Climate Change and Water NSW (DECCW) adopts a distance of 600m from a project as an appropriate study distance to assess the impact of traffic noise on adjoining property. Premise has therefore assumed any properties outside a 600m radius from the site entrance will not be adversely affected by any traffic noise from vehicles accelerating or decelerating to enter the site.

Desktop review identifies one dwelling, within the 600m radius from the site entrance off Broockmanns Road.

Noise and vibration impacts are expected to occur during both construction and operation of the project. In relation to construction activities this would include preparatory earthworks, delivery, and assembly of the Finley BESS infrastructure. During operation this would include operation of the Finley BESS and noise from associated vehicles.

4.4.1 NOISE ATTENUATION MEASURES

To mitigate the impact of noise to the dwellings, trucks entering and exiting the site are to adhere to the following guidelines.

- > No engine braking is to be utilised when slowing to enter the site entrance off Canalla Road;
- > Drivers are not to hold vehicles when exiting the site onto Canalla Road;
- > Excessive revving of engines is not permitted when exiting the site; and
- > Trucks are not to stage on surrounding roads prior to entering the site, adequate staging areas should be provided at the Finley BESS locations.

As the proposed increase in heavy vehicle traffic on surrounding roads is minimal, provided the above measures are adhered to, it is not anticipated the proposed increase in traffic will result in any noticeable additional noise to the identified properties.

4.5 Recommended works

4.5.1 FINLEY BESS SITE WORKS

This report has been prepared assuming that the works for the proposed Finley BESS as outlined in the concept design will be fully implemented during detailed design of the Finley BESS. These works include.

- > The ability for all vehicles to enter and exit the site in a forward direction;
- > Sufficient waiting areas for heavy vehicles, and
- > Provision of service vehicle unloading areas.



4.5.2 INTERSECTION OF RIVERINA HIGHWAY AND CANALLA ROAD

Section 4.3.1 identifies a BAR/BAL intersection will be required for the existing intersection between Riverina Highway and Canalla Road. From a review of the existing aerial imagery, this intersection currently exceeds requirements of a BAR/BAL intersection with a provision of left acceleration and deceleration lanes.

Upon further discussion with the TfNSW, the proponent will upgrade Riverina Highway, Canalla Road and Marantellis Drive intersection to conform to current BAL/BAR standards.

Figure 27 - Proposed upgrade of Riverina Highway, Canalla Road and Marantellis Road intersection - BAL/BAR configuration

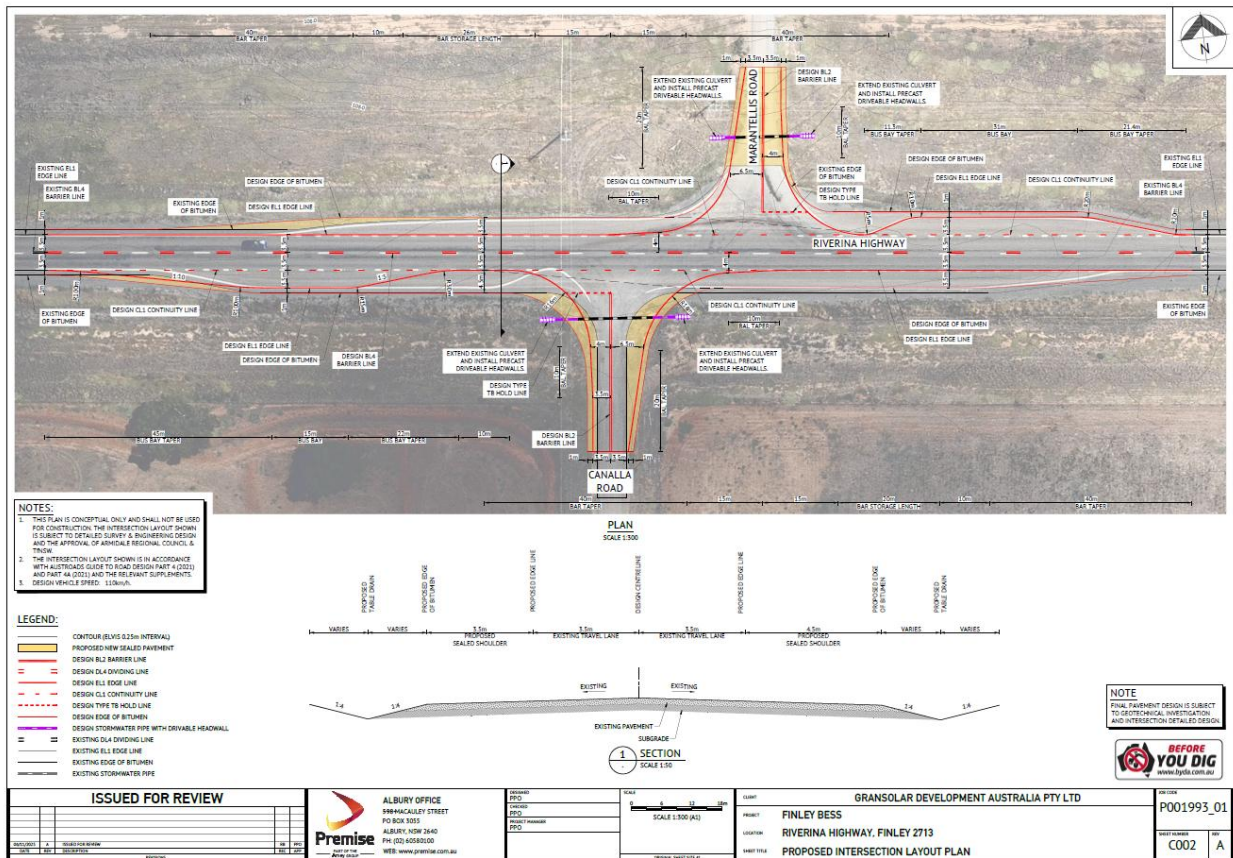

The upgrade comprises expansion of paved areas on Canalla Road and amendment to linemarking to conform to current Austroads standards for BAL/BAR.

4.5.2.1 Alternative configuration

Alternative configuration for intersection upgrade was considered. The option included AUL/CHR configuration that would require more significant pavement expansion and linemarking amendment resulting in stronger environmental impact. Assessment of warrants does not trigger requirement for this configuration.

Figure 28 - Alternative configuration for Riverina Highway, Canalla Road, Marantellis Road intersection - CHR/AUL

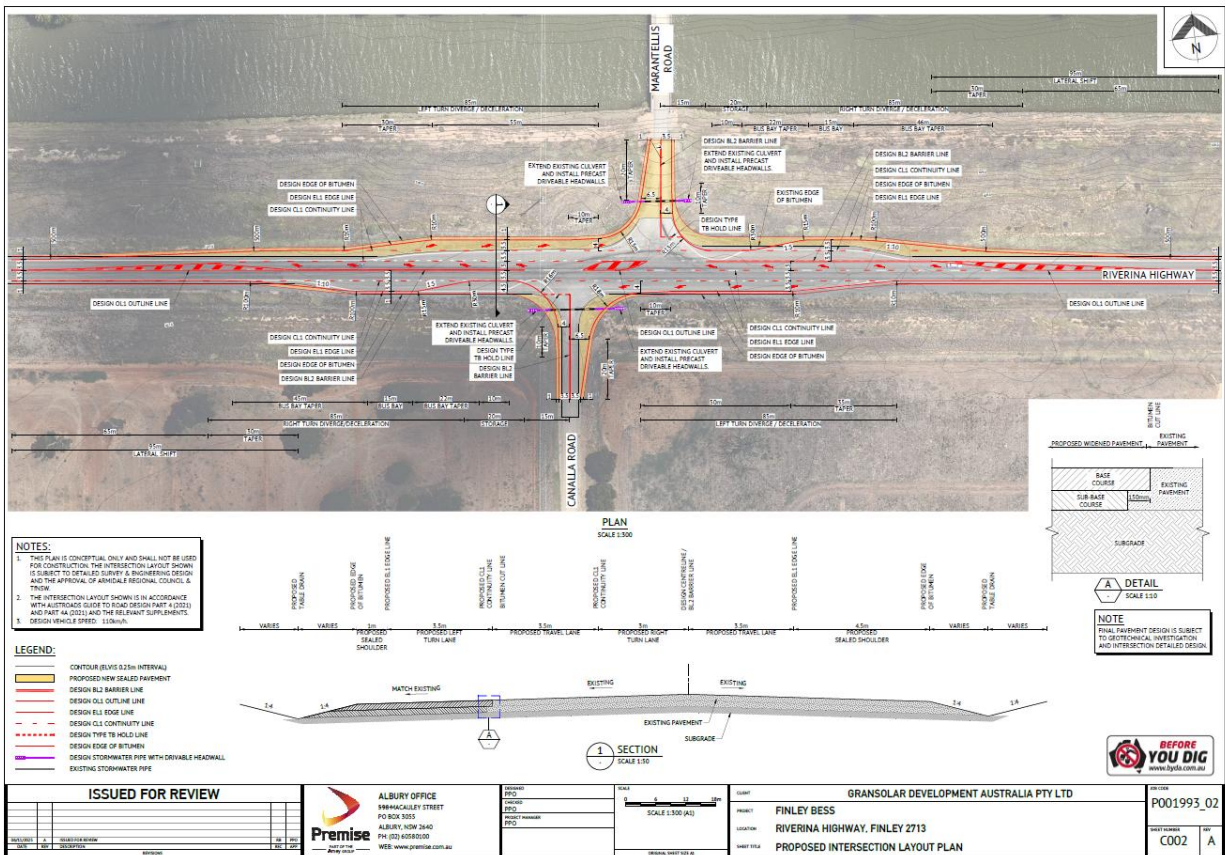

4.5.2.2 Safe System Assessment

This section will provide details of Safe System Assessment for the two upgrade options discussed above.

Table 23 - Setting the context

Prompt	Comment
<p>What is the reason for the project? Is there a specific crash type risk? Is it addressing specific issues such as poor speed limit compliance, road access, congestion, future traffic growth, freight movement, amenity concerns from the community, etc.</p>	<ul style="list-style-type: none"> The existing intersection predates current Austroads and TfNSW standards. The configuration is staggered T-intersection with auxiliary left turn lanes (AUL) on each stagger. Existing AULs do not comply to current geometric standards as outlined in Austroads. The application for Finley BESS development prompted TfNSW review of these intersections. While the current crash records show there weren't any recorded crashes in vicinity of intersections, it was determined there is a

What is the **function** of the road? Consider location, roadside land use, area type, speed limit, intersection type, presence of parking, public transport services and vehicle flows. What traffic features exist nearby (e.g. upstream and downstream)?

- risk of right angle crashes with the current configuration.
- The assessment will consider existing configuration and proposed two options for upgrade as shown in the **Figure 27** and **Figure 28**.

What is the **speed** environment? What is the current speed limit? Has it changed recently? Is it similar to other roads of this type? How does it compare to Safe System speeds? What is the acceptability of lowering the speed limit at this location?

- An undivided one lane per direction State Road with a 100 km/h speed limit and medium flows (1,000 – 5,000 VPD) – Riverina Highway.
- An undivided one lane per direction Local Road with a 100km/h speed limit and low flows (<1,000 VPD) – Marantellis Road and Canalla Road.
- Unsignalised full movement intersections of Riverina Highway, Marantellis Road and Canalla Road.
- Large rural and industrial lots abut the intersection with low traffic generation. Access to properties is from minor roads.
- Regional coach service runs along Riverina Highway. Coach stops are located in vicinity of the intersection and considered in the design.
- All roads have speed limit of 100km/h that is consistent with roads of similar type (Rural Highways and Rural Access Roads).
- There is no data on 85% operating speed; however it is assumed that 85% operating speed is close to speed limit.

What **road users** are present? Consider the presence of elderly, school children and cyclists. Also note what facilities are available to vulnerable road users (e.g. signalised crossings, bicycle lanes, school zone speed limits, etc.).

- There are no pedestrian or cycling facilities at the intersections. While it is not excluded that pedestrians or cyclists could be using verge or carriageway, surveys did not note their presence.
- Dominant road users are motor vehicle road users comprising mostly regional (passing traffic), given low turning movements at intersections.

What is the **vehicle** composition? Consider the presence of heavy vehicles (and what type), motorcyclists and other vehicles using the roadway.

- Riverina Highway carries up to 20% heavy vehicles. This is a RAV and OSOM route, therefore, large vehicles are present.
- Traffic surveys showed that Marantellis Road and Canalla Road carry low volumes of traffic, but a significant portion of the volumes are heavy vehicles (20-20%). These roads are not designated RAV or



OSOM routes.

The following table will outline Safe System Scoring of the current configuration, proposed BAL/BAR configuration (as shown in Figure 27), proposed CHR/AUL configuration (Figure 28) and subsequent findings.

Current Configuration							
	Run-off-road	Head-on	Intersection	Other (Rear end)	Pedestrian	Cyclist	Motorcyclist
Exposure	Moderate AADT volume	Moderate AADT volume	Moderate AADT volume	Moderate AADT volume	Very low pedestrian volume	Very low cyclist volume	Low motorcyclist volume
	2/4	2/4	2/4	2/4	0/4	0/4	1/4
Likelihood	Straight alignment, No record of similar crashes occurring	Lane of sufficient width; Audio-tactile treatment along the centre line, No record of similar crashes	Through traffic bypass right turning vehicles, No turning lanes, No record of similar crashes	Vehicles stopping to turn right with no bypass facility, No record of similar crashes	No pedestrian path, No crossing facilities	No cycling lane, No crossing facilities	Well surfaced Straight road, No record of similar crashes
	1/4	1/4	2/4	2/4	0/4	0/4	1/4
Severity	No infrangible objects in vicinity of the pavement edge	100km/h speed environment exceeding SS speed	100km/h speed environment exceeding SS speed	100km/h speed environment exceeding SS speed	100km/h speed environment exceeding SS speed	100km/h speed environment exceeding SS speed	100km/h speed environment exceeding SS speed
	2/4	4/4	4/4	4/4	4/4	4/4	4/4
Product	4/64	8/64	16/64	16/64	0/64	0/64	4/64
TOTAL				48/448			

Proposed BAL/BAR configuration							
	Run-off-road	Head-on	Intersection	Other (Rear end)	Pedestrian	Cyclist	Motorcyclist
Exposure	Moderate AADT volume	Moderate AADT volume	Moderate AADT volume	Moderate AADT volume	Very low pedestrian volume	Very low cyclist volume	Low motorcyclist volume
	2/4	2/4	2/4	2/4	0/4	0/4	1/4
Likelihood	Straight alignment, No record of similar crashes occurring	Lane of sufficient width; Audio-tactile treatment along the centre line, No record of similar crashes	Appropriate turning and bypass facilities	Appropriate turning and bypass facilities	No pedestrian path, No crossing facilities	No cycling lane, No crossing facilities	Well surfaced Straight road, No record of similar crashes
	1/4	1/4	1/4	1/4	0/4	0/4	1/4
Severity	No infrangible objects in vicinity of the pavement edge	100km/h speed environment exceeding SS speed	100km/h speed environment exceeding SS speed	100km/h speed environment exceeding SS speed	100km/h speed environment exceeding SS speed	100km/h speed environment exceeding SS speed	100km/h speed environment exceeding SS speed
	2/4	4/4	4/4	4/4	4/4	4/4	4/4

	2/4	4/4	4/4	4/4	4/4	4/4	4/4
Product	4/64	8/64	8/64	8/64	0/64	0/64	4/64
TOTAL	32/448						
Alternative design configuration – AUL / CHR							
	Run-off-road	Head-on	Intersection	Other (Rear end)	Pedestrian	Cyclist	Motorcyclist
Exposure	<i>Moderate AADT volume</i>	<i>Moderate AADT volume</i>	<i>Moderate AADT volume</i>	<i>Moderate AADT volume</i>	<i>Very low pedestrian volume</i>	<i>Very low cyclist volume</i>	<i>Low motorcyclist volume</i>
	2/4	2/4	2/4	2/4	0/4	0/4	1/4
Likelihood	<i>Straight alignment, No record of similar crashes occurring</i>	<i>Lane of sufficient width; Audio-tactile treatment along the centre line, No record of similar crashes</i>	<i>Appropriate turning and bypass facilities</i>	<i>Appropriate turning and bypass facilities</i>	<i>No pedestrian path No crossing facilities</i>	<i>No cycling lane No crossing facilities</i>	<i>Well surfaced Straight road No record of similar crashes</i>
	1/4	1/4	1/4	1/4	0/4	0/4	1/4
Severity	<i>No infrangible objects in vicinity of the pavement edge</i>	<i>100km/h speed environment exceeding SS speed</i>	<i>100km/h speed environment exceeding SS speed</i>	<i>100km/h speed environment exceeding SS speed</i>	<i>100km/h speed environment exceeding SS speed</i>	<i>100km/h speed environment exceeding SS speed</i>	<i>100km/h speed environment exceeding SS speed</i>
	2/4	4/4	4/4	4/4	4/4	4/4	4/4
Product	4/64	8/64	8/64	8/64	0/64	0/64	4/64
TOTAL	32/448						

Both upgrade options score 32 out of a possible 448 for the check cases and considers the safer speeds, safer roads and roadsides pillars, showing improvement from the current situation (Score 48). The closer the score is to zero, the more the segment of infrastructure in question is in alignment with Safe System principles. The low score on the Safe System Matrix demonstrates strong compliance with Safe System objectives across all check cases; however it is obvious that the more expansive treatment won't necessarily result in a better Safe System score.

Given that the intersection warrants clearly show that BAL/BAR treatment is sufficient there is no safety benefit to the expanded intersection footprint that will have more significant environmental and maintenance impact.

Table below shows user exposure Safe System matrix scoring system.

Road user exposure	0 = there is no exposure to a certain crash type.	1 = volumes of vehicles that may be involved in a particular crash type are particularly low, and therefore exposure is low.	2 = volumes of vehicles that may be involved in a particular crash type are moderate, and therefore exposure is moderate.	3 = volumes of vehicles that may be involved in a particular crash type are high, and therefore exposure is high.	4 = volumes of vehicles that may be involved in a particular crash type are very high, or the road is very long, and therefore
	This might mean there is no side flow or intersecting roads, no cyclists, no				

	pedestrians, or motorcyclists).	For run-of-road, head-on, intersection and 'other' crash types, AADT is < 1 000 per day. For cyclist, pedestrian and motorcycle crash types, volumes are < 10 units per day.	For run-of-road, head-on, intersection and 'other' crash types, AADT is between 1 000 and 5 000 per day. For cyclist, pedestrian and motorcycle crash types, volumes are 10–50 units per day.	For run-of-road, head-on, intersection and 'other' crash types, AADT is between 5 000 and 10 000 per day. For cyclist, pedestrian and motorcycle crash types, volumes are 50–100 units per day.	exposure is very high. For run-of-road, head-on, intersection and 'other' crash types, AADT is > 10 000 per day. For cyclist, pedestrian and motorcycle crash types, volumes are >100 units per day.
--	---------------------------------	---	--	--	--

Table 24 - Additional Safe System Components

Road user	
<p>Are road users likely to be alert and compliant, or are there factors that might influence this?</p> <hr/> <p>What are the expected compliance and enforcement levels (alcohol/drugs, speed, road rules, and driving hours) and what is the likelihood of driver fatigue? Can enforcement of these issues be conducted safely?</p> <hr/> <p>Are there special road uses (e.g. entertainment precincts, elderly, children, on-road activities), distraction by environmental factors (e.g. commerce, tourism), or risk-taking behaviours?</p>	<ul style="list-style-type: none"> In general, there is passing regional traffic. It is expected that drivers are appropriately licenced and experienced. Drivers expected to be compliant. Driver fatigue not expected to be a factor. No other special road uses expected.
Vehicle	
<p>What level of alignment is there with the ideal of safer vehicles?</p> <hr/> <p>Are there factors which might attract large numbers of unsafe vehicles? Is the percentage of heavy vehicles too high for the proposed/existing road design?</p> <hr/> <p>Are there enforcement resources in the area to detect non-roadworthy, overloaded or unregistered vehicles and thus remove them from the network? Can enforcement of these issues be conducted safely?</p> <hr/> <p>Has vehicle breakdown been catered for?</p>	<ul style="list-style-type: none"> Roads at present carry traffic well under capacity. There is a high number of commercial and heavy vehicles, that are more strictly regulated than passenger vehicles. No known particular vehicle enforcement in addition to standard legal enforcement. Verge is wide enough to accommodate vehicle in a breakdown situation.
Post-crash care	
<p>Are there issues that might influence safe and efficient post-crash care in the event of a severe injury?</p> <hr/> <p>Do emergency and medical services operate as</p>	<ul style="list-style-type: none"> Verge may be used for emergency stops. Finley Health Service is located at approximately 6 kilometres away.



efficiently and rapidly as possible?

Are other road users and emergency response teams protected during a crash event? Are drivers provided the correct information to address travelling speeds on the approach and adjacent to the incident? Is there reliable information available via radio, VMS etc.?

Is there provision for e-safety (i.e. safety systems based on modern information and communication technologies, C-ITS)?

4.5.3 INTERSECTION OF CANALLA ROAD AND BROOCKMANN'S DRIVE

As the Broockmann's Drive crossovers will be designated for light vehicles and Transgrid vehicles, there will be no need for the intersection upgrade to cater to construction of Finley BESS.

4.5.4 CANALLA ROAD AND BROOCKMANN'S DRIVE

This development will not require upgrade of Canalla Road or Broockmann's Drive.



5. HEAVY VEHICLE AND OSOM ROUTES

OSOM Route Survey report was prepared by Ares Group in January 2026. The report details outcomes of a desktop route survey, and this section will outline the summary of OSOM Route Survey findings.

During the construction period, heavy vehicles, special purpose vehicles and Class 1 OSOM vehicles are likely to come from different directions; however, OSOM Route Survey focuses on the transformer transporter, as the largest vehicle that will access the site.

5.1 Design Vehicle

The OSOM Route Survey report outlines that the required vehicle configuration is likely to include prime mover, low loader platform with dolly and goose neck, as shown in the **Figure 11**. If the weight of the transformer requires it, a push truck may be required; however, it is unlikely to impact the swept path impact analysis.

The vehicle will be accompanied by three (3) pilot vehicles, operated by appropriately certified drivers.

5.2 Proposed OSOM Route

As the proposed port of import is Melbourne Port, the anticipated route is shown in **Figure 29** below. The route can be viewed via interactive link [Finley BESS OSOM Route](#).

The route in principle follows approved OSOM Class 1 route (NSW and VIC), although liaison with relevant authorities will be required on sections of the route that allow for a conditional access. The geometric analysis identified following requirement for modification:

- > Pinch Point 07 – Right Turn Goulburn Valley Hwy & River Rd – one sign to be made moveable
- Typically Construction Traffic Management Plan (TMP) is one of conditions of development consent and the details of management of construction traffic impacts will be detailed in this document. Further to this, the transporter delivering transformer will provide trip-specific traffic management plan detailing all measures and mitigations.

Based on the preliminary desktop assessment, the vehicle will require traffic management to complete following manoeuvres:

- > Left turn at Francis Street and Hyde Street;
- > Right turn from Hyde Street to Simcock Avenue;
- > Right Turn from Simcock Avenue to West Gate FWY on-ramp;
- > Left turn from Riverina Hwy to Canalla Road.

The OSOM vehicle will likely traverse medians and splitter islands at following intersections:

- > Hyde Street and Simcock Avenue;
- > Goulburn Valley Highway/ River Road;

> Riverina Highway and Newell Highway.

The heavy vehicle crossover on Canalla Road will be designed to accommodate movements of the largest OSOM vehicle.

The vehicle will require relevant permits from the National Heavy Vehicle Regulator (NHVR), state and local government authorities and from other relevant third-party authorities such as electricity/telco authorities, rail/tram authorities, toll road and tunnel operators. Closer to the day of transport a field survey will be required to confirm findings of desktop analysis. Given that the Victorian authorities are amending vehicle restrictions in Melbourne Metro area, the final route may be amended somewhat to reflect requirements current at the time of transformer transport.

Figure 29 - Proposed OSOM route for transformer transportation (source: OSOM Route Survey, Ares Group, January 2026)

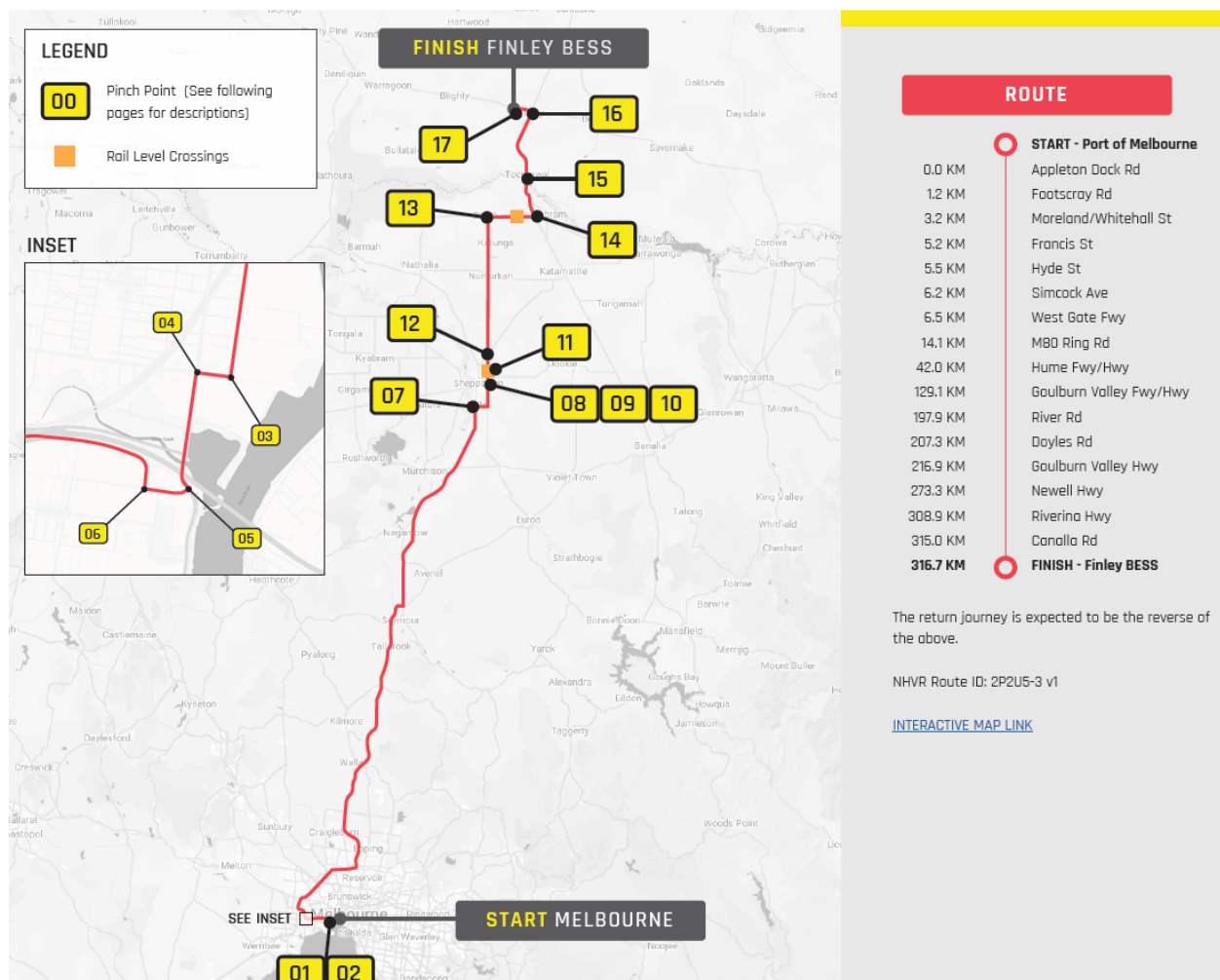

The route is estimated to be approximately 320km long and as vehicles will be moving at slow speeds due to heavy load, it is anticipated that the inbound trip will be approximately 6-7 hours long. **Table 25** outlines proposed stops for fatigue management although other stops are available along the route if needed for emergency stops.

Table 25 - Proposed truck stops for fatigue management (source: OSOM Route Survey, Ares Group, March 2025)

No	KP	Rest Stop Name
01	62	Kalkallo Truck Parking
02	197	Kialla Rest Area
03	246	Numurkah Rest Area

5.3 Railway Crossings

There are two railway crossings on the route. Once the date of the transport is known and the details of cargo and required vehicles, approvals will be sought from V/ Line as the relevant authority.

Table 26 - Location of railway crossings (source: OSOM Route Survey, Ares Group, March 2025)

Crossing No 1	Crossing No 2
Grahamvale Road level crossing	Murray Valley Highway level crossing, Strathmerton
Tocumwal line	

5.4 Bridges and Culverts

Bridge assessments will still be required from the state road authorities (Victoria’s DTP and Transport for NSW) to confirm that bridges along the route can be crossed. Axle weights are proposed to be 15.5 tons per row.

A bridge assessment was conducted on 20 October 2025 for route 2NLNB-8 from Tocumwal to Finley. This assessment validates the capacity of the bridge to support the loads of the permit vehicle. The following conditions will be implemented at all bridge crossings along the route:

- > The vehicles travelling on all the bridges on the route at a speed not exceeding 10km/h with no sudden braking or acceleration.
- > No other vehicles are permitted on the bridge while the Permit vehicle is on the bridge
- > The vehicle shall travel only along the centreline of the carriageway of all the bridges.
- > The permit vehicle dolly and platform’s gross loading are to be equally distributed between all axles of the dolly and platform
- > Ensuring there is sufficient height clearance beneath all overhead structures along the route
- > The width of the vehicle and load can safely navigate all bridges on the route
- > No return trip is permitted



6. CONCLUSION

The assessment of the additional net traffic generated by the proposed development, concluded the following:

- > Finley BESS will create the greatest traffic impact in construction phase, while the operational phase will have negligible impact. Traffic impact of decommissioning phase will depend on the technology available at the time and should be assessed closer to the time of decommissioning. Nevertheless, the impact is expected to be lower than in construction phase;
- > The increase in the traffic volumes on the surrounding road network will not change the classifications of the roads under the functional road hierarchy;
- > The percentage increase in traffic volume is not considered significant and the net daily traffic volume and peak hour volume generated by construction of Finley BESS are easily absorbed into the surrounding road network with minimal impact on the capacity of the existing traffic streams using the road system;
- > The Riverina Highway/ Canalla Road/ Marantellis Road intersection will continue to operate with a Level of Service A during the AM and PM peaks during the construction of the proposed development;
- > The applicant will upgrade Riverina Highway / Canalla Road/Marantellis Road intersection to conform with the current standards for BAL/BAR configuration per relevant Austroads guidelines and TfNSW supplements.
- > The existing intersections of leading to the development site have appropriate sight distances to allow for the safe movement of both heavy and passenger vehicles;
- > Heavy Vehicle crossover on Canalla Road will be designed to accommodate movements of the largest OSOM vehicles;
- > It is not anticipated there will be any additional impact on traffic safety through the increase of Finley BESS traffic using the existing intersection of Riverina Highway and Canalla Road; and
- > Independent OSOM Route Study confirms that the transport of the largest indivisible element (transformer) is feasible with minor amendments along the route and traffic management at Riverina Hwy/Canalla Rd intersection.

Based on the findings above, it can be concluded that Finley BESS will not create unacceptable impact on the existing road network in any of the project phases.



APPENDIX A

TRAFFIC COUNT DATA



Job No. : AUVIC11637
 Client : Premise
 Suburb : Finley
 Location : 1. Riverina Hwy / Canalla Rd / Marantellis Rd

Day/Date : Tue, 18 February 2025
 Weather : Fine
 Description : Classified Intersection Count
 : Peak Hour Summary

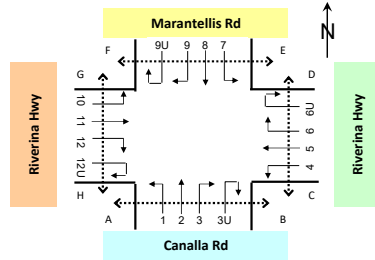

Approach	Canalla Rd						Riverina Hwy						Marantellis Rd						Riverina Hwy						Grand Total
	Light Vehicles	Heavy Vehicles	AVs	RAV	OSOW	Total	Light Vehicles	Heavy Vehicles	AVs	RAV	OSOW	Total	Light Vehicles	Heavy Vehicles	AVs	RAV	OSOW	Total	Light Vehicles	Heavy Vehicles	AVs	RAV	OSOW	Total	
08:00 to 09:00	1	0	0	0	0	1	43	4	4	8	0	59	1	0	0	0	0	1	53	5	2	2	0	62	123
15:00 to 16:00	0	1	0	0	0	1	42	6	8	5	0	61	0	0	0	0	0	0	45	0	1	6	0	52	114

Approach	Canalla Rd						Riverina Hwy						Marantellis Rd						Riverina Hwy						Grand Total
	Light Vehicles	Heavy Vehicles	AVs	RAV	OSOW	Total	Light Vehicles	Heavy Vehicles	AVs	RAV	OSOW	Total	Light Vehicles	Heavy Vehicles	AVs	RAV	OSOW	Total	Light Vehicles	Heavy Vehicles	AVs	RAV	OSOW	Total	
06:00 to 07:00	0	0	0	0	0	0	24	1	1	0	0	26	1	0	0	0	0	1	9	5	1	1	0	16	43
06:15 to 07:15	0	0	0	0	0	0	27	2	1	0	0	30	1	0	0	0	0	1	13	5	1	3	0	22	53
06:30 to 07:30	0	0	0	0	0	0	30	2	1	1	0	34	0	0	0	0	0	0	14	2	0	3	0	19	53
06:45 to 07:45	0	0	0	0	0	0	28	6	0	2	0	36	0	0	0	0	0	0	21	2	0	5	0	28	64
07:00 to 08:00	1	0	0	0	0	1	30	7	0	5	0	42	0	0	0	0	0	0	28	1	0	5	0	34	77
07:15 to 08:15	2	0	0	0	0	2	31	6	2	6	0	45	0	0	0	0	0	0	40	2	1	3	0	46	93
07:30 to 08:30	2	0	0	0	0	2	35	6	2	7	0	50	1	0	0	0	0	1	45	3	1	3	0	52	105
07:45 to 08:45	2	0	0	0	0	2	34	2	3	10	0	49	1	0	0	0	0	1	48	5	2	2	0	57	109
08:00 to 09:00	1	0	0	0	0	1	43	4	4	8	0	59	1	0	0	0	0	1	53	5	2	2	0	62	123
08:15 to 09:15	0	0	0	0	0	0	47	5	5	9	0	66	2	0	0	0	0	2	41	4	1	3	0	49	117
08:30 to 09:30	0	0	0	0	0	0	46	6	6	8	0	66	2	0	0	0	0	2	42	5	2	3	0	52	120
08:45 to 09:45	0	0	0	0	0	0	47	7	10	4	0	68	2	0	0	0	0	2	40	2	2	3	0	47	117
09:00 to 10:00	0	0	0	0	0	0	37	4	9	6	0	56	2	0	0	0	0	2	41	3	4	3	0	51	109
AM Totals	2	0	0	0	0	2	134	16	14	19	0	183	4	0	0	0	0	4	131	14	7	11	0	163	352
15:00 to 16:00	0	1	0	0	0	1	42	6	8	5	0	61	0	0	0	0	0	0	45	0	1	6	0	52	114
15:15 to 16:15	0	1	0	0	0	1	40	5	9	5	0	59	1	0	0	0	0	1	43	2	1	6	0	52	113
15:30 to 16:30	0	1	0	0	0	1	43	1	6	5	0	55	1	0	0	0	0	1	41	3	1	3	0	48	105
15:45 to 16:45	0	0	0	0	0	0	45	1	4	5	0	55	1	0	0	0	0	1	39	4	1	1	0	45	101
16:00 to 17:00	0	0	0	0	0	0	48	1	2	2	0	53	1	0	0	0	0	1	35	4	1	1	0	41	95
16:15 to 17:15	0	0	0	0	0	0	45	1	0	3	0	49	0	0	0	0	0	0	28	3	2	4	0	37	86
16:30 to 17:30	0	0	0	0	0	0	47	1	0	2	0	50	0	0	0	0	0	0	29	3	2	4	1	39	89
16:45 to 17:45	0	0	0	0	0	0	40	1	1	2	0	44	0	0	0	0	0	0	28	2	3	4	1	38	82
17:00 to 18:00	1	0	1	0	0	2	37	1	3	2	0	43	0	0	0	0	0	0	26	2	2	4	1	35	80
17:15 to 18:15	1	0	1	0	0	2	29	1	3	1	0	34	0	0	0	0	0	0	29	1	3	1	1	35	71
17:30 to 18:30	1	0	1	0	0	2	24	1	3	1	0	29	0	0	0	0	0	0	30	1	3	2	0	36	67
17:45 to 18:45	1	0	1	0	0	2	23	1	3	0	0	27	0	0	0	0	0	0	29	1	3	3	0	36	65
18:00 to 19:00	0	0	0	0	0	0	20	1	2	1	0	24	0	0	0	0	0	0	23	1	3	4	0	31	55
PM Totals	1	1	1	0	0	3	147	9	15	10	0	181	1	0	0	0	0	1	129	7	7	15	1	159	344

Job No. : AUVIC11637
 Client : Premise
 Suburb : Finley
 Location : 1. Riverina Hwy / Canalla Rd / Marantellis Rd

Day/Date : Wed, 19 February 2025
 Weather : Fine
 Description : Classified Intersection Count
 : Peak Hour Summary

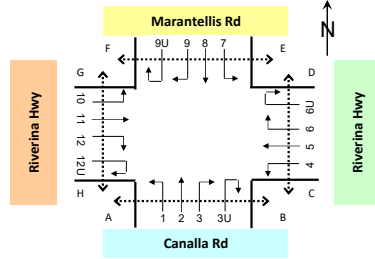

Approach	Canalla Rd						Riverina Hwy						Marantellis Rd						Riverina Hwy						Grand Total	
	Light Vehicles	Heavy Vehicles	AVs	RAV	OSOW	Total	Light Vehicles	Heavy Vehicles	AVs	RAV	OSOW	Total	Light Vehicles	Heavy Vehicles	AVs	RAV	OSOW	Total	Light Vehicles	Heavy Vehicles	AVs	RAV	OSOW	Total		
09:00 to 10:00	1	0	0	0	0	1	51	6	5	14	0	76	0	0	0	0	0	0	49	4	2	3	1	59	136	
15:15 to 16:15	1	1	0	0	0	2	62	8	4	5	0	79	0	0	0	0	1	0	1	41	4	2	6	0	53	135

Approach	Canalla Rd						Riverina Hwy						Marantellis Rd						Riverina Hwy						Grand Total
	Light Vehicles	Heavy Vehicles	AVs	RAV	OSOW	Total	Light Vehicles	Heavy Vehicles	AVs	RAV	OSOW	Total	Light Vehicles	Heavy Vehicles	AVs	RAV	OSOW	Total	Light Vehicles	Heavy Vehicles	AVs	RAV	OSOW	Total	
06:00 to 07:00	0	0	0	0	0	0	22	5	2	2	0	31	1	0	0	0	0	1	8	5	1	1	0	15	47
06:15 to 07:15	0	0	0	0	0	0	25	7	3	3	0	38	1	0	0	0	0	1	11	6	2	2	0	21	60
06:30 to 07:30	0	0	0	0	0	0	25	7	3	5	0	40	2	0	0	0	0	2	17	6	2	3	1	29	71
06:45 to 07:45	0	0	0	0	0	0	26	6	3	5	0	40	2	0	0	0	0	2	28	3	2	3	1	37	79
07:00 to 08:00	0	0	0	0	0	0	27	6	2	5	0	40	1	0	0	0	0	1	34	2	3	3	1	43	84
07:15 to 08:15	0	0	0	0	0	0	27	4	2	4	0	37	1	0	0	0	0	1	45	1	1	2	1	50	88
07:30 to 08:30	1	0	0	0	0	1	27	5	1	3	0	36	1	0	0	0	0	1	48	2	2	2	0	54	92
07:45 to 08:45	1	0	0	0	0	1	34	4	1	5	0	44	1	0	0	0	0	1	48	3	2	2	0	55	101
08:00 to 09:00	1	0	0	0	0	1	42	5	1	6	0	54	1	0	0	0	0	1	50	3	3	3	0	59	115
08:15 to 09:15	1	0	0	0	0	1	47	7	0	8	0	62	1	0	0	0	0	1	47	3	3	4	0	57	121
08:30 to 09:30	0	0	0	0	0	0	51	8	3	11	0	73	0	0	0	0	0	0	48	3	2	4	0	57	130
08:45 to 09:45	0	0	0	0	0	0	51	7	4	16	0	78	0	0	0	0	0	0	45	2	3	5	0	55	133
09:00 to 10:00	1	0	0	0	0	1	51	6	5	14	0	76	0	0	0	0	0	0	49	4	2	3	1	59	136
AM Totals	2	0	0	0	0	2	142	22	10	27	0	201	3	0	0	0	0	3	141	14	9	10	2	176	382
15:00 to 16:00	2	1	0	0	0	3	56	8	3	3	0	70	0	0	0	1	0	1	43	8	1	5	0	57	131
15:15 to 16:15	1	1	0	0	0	2	62	8	4	5	0	79	0	0	0	1	0	1	41	4	2	6	0	53	135
15:30 to 16:30	1	1	0	0	0	2	47	6	3	4	0	60	0	0	0	1	0	1	41	3	3	11	0	58	121
15:45 to 16:45	1	0	0	0	0	1	47	5	2	5	0	59	0	0	0	1	0	1	37	3	2	11	0	53	114
16:00 to 17:00	1	0	0	0	0	1	41	1	1	5	0	48	1	0	0	0	0	1	42	3	2	11	0	58	108
16:15 to 17:15	0	0	0	0	0	0	38	1	0	3	0	42	1	0	0	0	0	1	40	3	1	14	0	58	101
16:30 to 17:30	0	0	0	0	0	0	43	1	0	4	0	48	1	0	0	0	0	1	31	2	1	9	0	43	92
16:45 to 17:45	0	0	0	0	0	0	39	1	1	3	0	44	2	0	0	0	0	2	33	1	1	9	0	44	90
17:00 to 18:00	0	0	0	0	0	0	42	1	2	3	0	48	1	0	0	0	0	1	39	0	1	6	0	46	95
17:15 to 18:15	0	0	0	0	0	0	37	0	3	5	0	45	1	0	0	0	0	1	32	0	1	4	0	37	83
17:30 to 18:30	0	0	0	0	0	0	28	0	3	5	0	36	1	0	0	0	0	1	37	0	1	5	0	43	80
17:45 to 18:45	0	0	0	0	0	0	23	0	3	4	0	30	0	0	0	0	0	0	32	0	2	4	0	38	68
18:00 to 19:00	0	0	0	0	0	0	17	0	2	5	0	24	0	0	0	0	0	0	19	0	3	4	0	26	50
PM Totals	3	1	0	0	0	4	156	10	8	16	0	190	2	0	0	1	0	3	143	11	7	26	0	187	384

Job No. : AUVIC11637
 Client : Premise
 Suburb : Finley
 Location : 1. Riverina Hwy / Canalla Rd / Marantellis Rd

Day/Date : Thu, 20 February 2025
 Weather : Fine
 Description : Classified Intersection Count
 : Peak Hour Summary

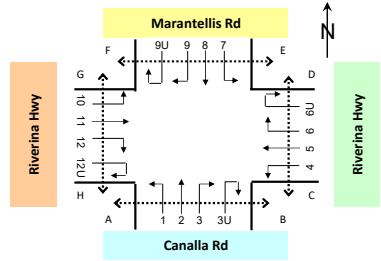

Approach	Canalla Rd						Riverina Hwy						Marantellis Rd						Riverina Hwy						Grand Total
	Light Vehicles	Heavy Vehicles	AVs	RAV	OSOW	Total	Light Vehicles	Heavy Vehicles	AVs	RAV	OSOW	Total	Light Vehicles	Heavy Vehicles	AVs	RAV	OSOW	Total	Light Vehicles	Heavy Vehicles	AVs	RAV	OSOW	Total	
AM 07:45 to 08:45	1	0	0	0	0	1	35	4	5	7	0	51	2	0	0	0	0	2	36	8	5	2	0	54	108
PM 15:15 to 16:15	0	1	0	0	0	1	38	2	4	2	0	46	1	0	0	0	0	1	56	5	2	7	0	70	118

Approach	Canalla Rd						Riverina Hwy						Marantellis Rd						Riverina Hwy						Grand Total
	Light Vehicles	Heavy Vehicles	AVs	RAV	OSOW	Total	Light Vehicles	Heavy Vehicles	AVs	RAV	OSOW	Total	Light Vehicles	Heavy Vehicles	AVs	RAV	OSOW	Total	Light Vehicles	Heavy Vehicles	AVs	RAV	OSOW	Total	
06:00 to 07:00	0	0	0	0	0	0	24	5	2	2	1	34	1	0	0	0	0	1	8	2	3	0	0	13	48
06:15 to 07:15	0	0	0	0	0	0	27	5	2	1	0	35	1	0	0	0	0	1	14	4	3	0	0	21	57
06:30 to 07:30	1	0	0	0	0	1	24	8	2	0	0	34	1	0	0	0	0	1	13	6	5	0	0	24	60
06:45 to 07:45	1	0	0	0	0	1	28	7	4	3	1	43	1	0	0	0	0	1	19	6	2	0	0	27	72
07:00 to 08:00	1	0	0	0	0	1	31	7	5	4	1	48	0	0	0	0	0	0	29	5	2	1	0	37	86
07:15 to 08:15	2	0	0	0	0	2	34	5	4	6	1	50	0	0	0	0	0	0	29	5	3	1	0	38	90
07:30 to 08:30	1	0	0	0	0	1	35	4	6	9	1	55	1	0	0	0	0	1	38	5	1	2	0	46	103
07:45 to 08:45	1	0	0	0	0	1	35	4	5	7	0	51	2	0	0	0	0	2	39	8	5	2	0	54	108
08:00 to 09:00	1	0	0	0	0	1	30	5	3	7	1	46	3	0	0	0	0	3	34	10	6	1	0	51	101
08:15 to 09:15	0	0	0	0	0	0	28	7	4	5	1	45	3	0	0	0	0	3	39	10	6	1	0	56	104
08:30 to 09:30	1	0	0	0	0	1	27	7	4	2	1	41	2	0	0	0	0	2	36	9	8	1	0	54	98
08:45 to 09:45	1	0	0	0	0	1	30	7	5	1	1	44	1	0	0	0	0	1	42	9	6	1	0	58	104
09:00 to 10:00	2	0	0	0	0	2	29	10	6	1	0	46	1	0	0	0	0	1	39	9	6	1	0	55	104
AM Totals	4	0	0	0	0	4	114	27	16	14	3	174	5	0	0	0	0	5	110	26	17	3	0	156	339
15:00 to 16:00	0	1	0	0	0	1	36	3	5	3	0	47	0	0	0	0	0	0	52	5	2	8	0	67	115
15:15 to 16:15	0	1	0	0	0	1	38	2	4	2	0	46	1	0	0	0	0	1	56	5	2	7	0	70	118
15:30 to 16:30	0	1	0	0	0	1	40	1	2	1	0	44	1	0	0	0	0	1	46	4	2	8	0	60	106
15:45 to 16:45	0	0	0	0	0	0	39	1	2	2	0	44	2	0	0	0	0	2	36	5	2	9	0	52	98
16:00 to 17:00	0	0	0	0	0	0	39	0	3	2	0	44	3	0	0	0	0	3	36	2	1	7	0	46	93
16:15 to 17:15	1	0	0	0	0	1	40	0	3	2	0	45	2	0	0	0	0	2	30	3	1	4	0	38	86
16:30 to 17:30	1	0	0	0	0	1	42	0	3	1	0	46	2	0	0	0	0	2	37	3	2	2	0	44	93
16:45 to 17:45	1	0	0	0	0	1	43	0	2	1	0	46	1	0	0	0	0	1	35	1	1	3	0	40	88
17:00 to 18:00	1	0	0	0	0	1	44	0	0	2	0	46	0	0	0	0	0	0	32	1	2	4	0	39	86
17:15 to 18:15	0	0	0	0	0	0	34	0	1	3	0	38	0	0	0	0	0	0	36	1	2	4	0	43	81
17:30 to 18:30	0	0	0	0	0	0	27	1	1	7	0	36	0	0	0	0	0	0	31	1	1	8	0	41	77
17:45 to 18:45	0	0	0	0	0	0	18	1	1	6	0	26	0	0	0	0	0	0	30	1	2	6	0	39	65
18:00 to 19:00	0	0	0	0	0	0	11	1	1	7	0	20	0	0	0	0	0	0	28	1	1	7	0	37	57
PM Totals	1	1	0	0	0	2	130	4	9	14	0	157	3	0	0	0	0	3	148	9	6	26	0	189	351

APPENDIX B

SIDRA OUTPUT



USER REPORT FOR NETWORK

All Movement Classes

Project: P001993_M01-M02

Template: Default Network User Report

Network: N01 [AM 2025 (Network Folder: Base 2025)]

AM 2025

Network Category: Base Year

Network Layout

Layout pictures are schematic functional drawings reflecting input data. They are not design drawings.

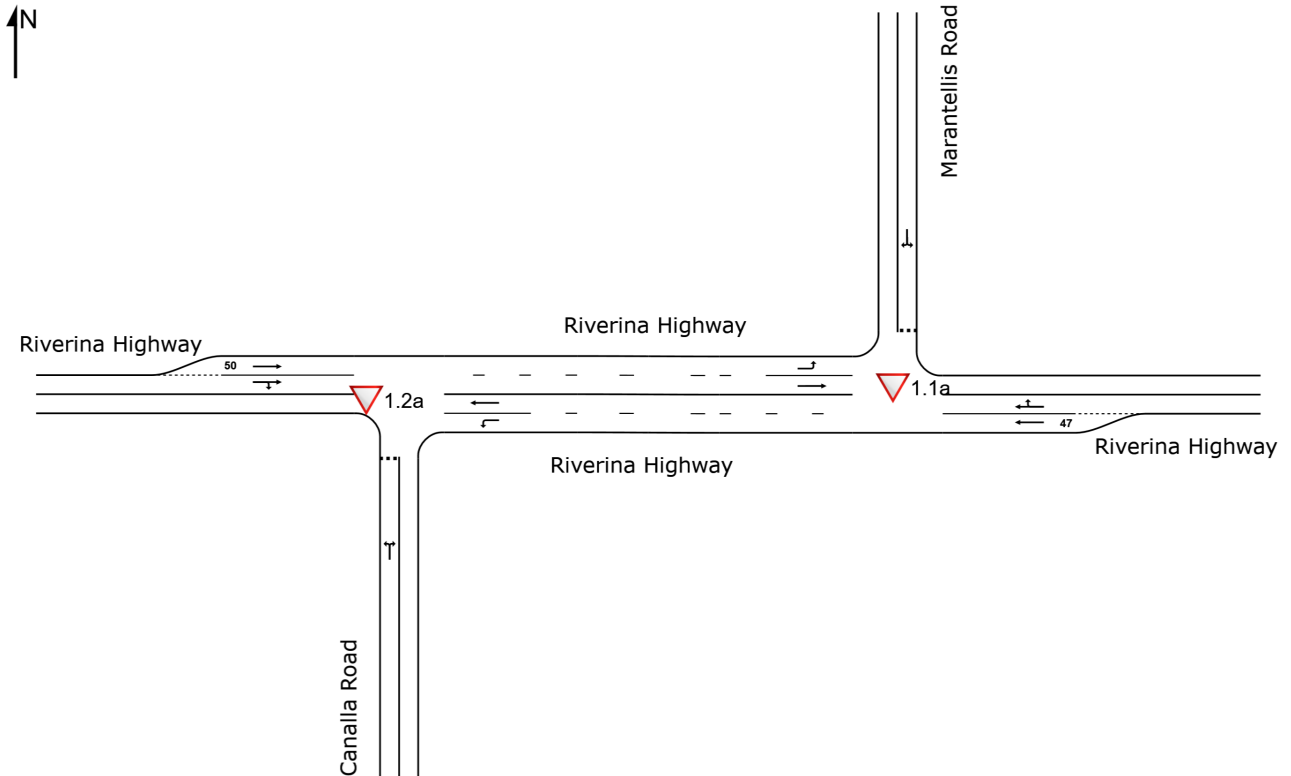

Network Flows - Demand

Use the button below to open or close all popup boxes. Click value labels to open selected ones. Click and drag popup boxes to move to preferred positions.

Open All Popups

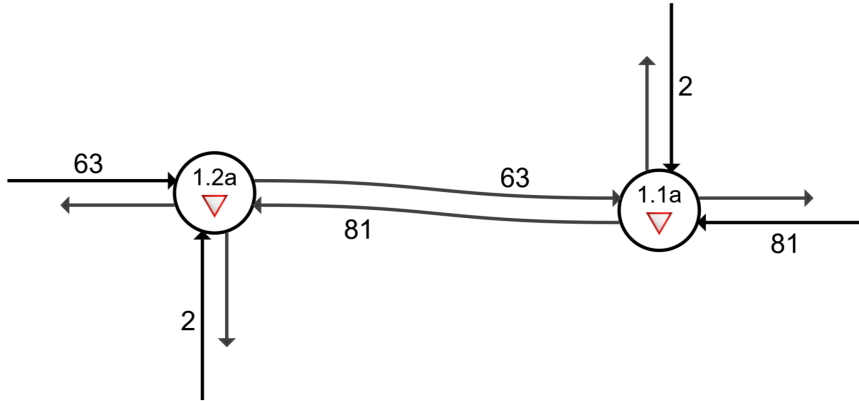

Approach Level of Service

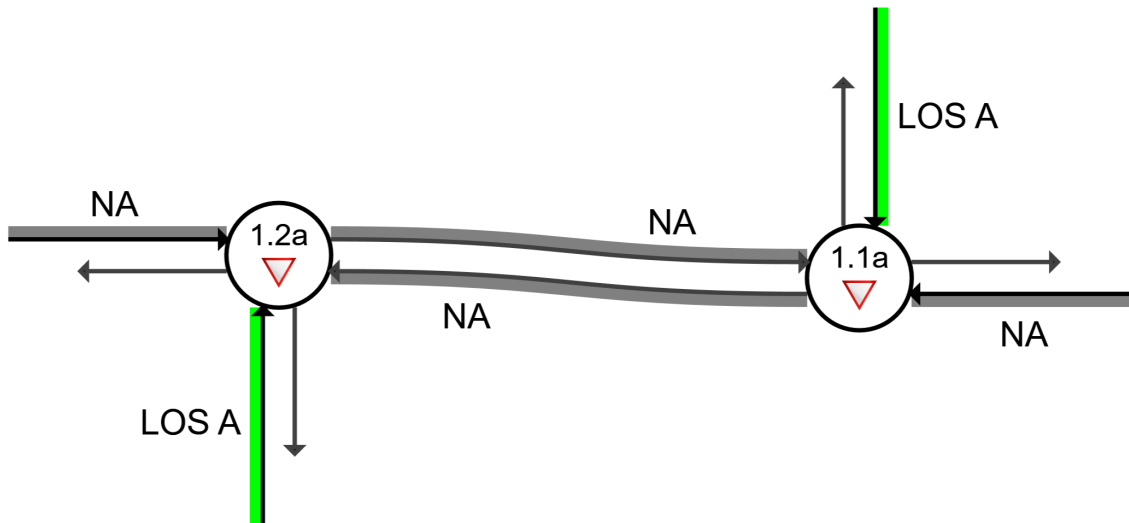

Colour code based on Level of Service

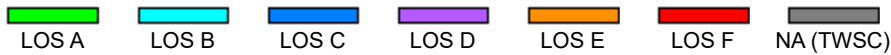

Site Level of Service (LOS) Method: Delay (SIDRA). Site LOS Method is specified in the Network Data dialog (Network tab).

NA (TWSC): Level of Service is not defined for major road approaches or the intersection as a whole for Two-Way Sign Control (HCM LOS rule).

Delay Model: SIDRA Standard (Geometric Delay is included).

Network Performance - Hourly Values			
Performance Measure	Vehicles	Per Unit Distance	Persons
Network Level of Service (LOS)	LOS A		
Speed Efficiency	0.99		
Travel Time Index	9.92		
Congestion Coefficient	1.01		
Travel Speed (Average)	98.4 km/h		98.4 km/h
Travel Distance (Total)	328.3 veh-km/h		393.9 pers-km/h
Travel Time (Total)	3.3 veh-h/h		4.0 pers-h/h
Desired Speed (Program)	99.1 km/h		
Demand Flows (Total for all Sites)	293 veh/h		351 pers/h
Arrival Flows (Total for all Sites)	293 veh/h		351 pers/h
Demand Flows (Entry Total)	148 veh/h		
Midblock Inflows (Total)	0 veh/h		
Midblock Outflows (Total)	0 veh/h		
Percent Heavy Vehicles (Demand)	25.2 %		
Percent Heavy Vehicles (Arrival)	25.2 %		
Degree of Saturation	0.072		
Control Delay (Total)	0.02 veh-h/h		0.02 pers-h/h
Control Delay (Average)	0.2 sec		0.2 sec
Control Delay (Worst Lane)	8.4 sec		
Control Delay (Worst Movement)	8.7 sec		8.7 sec
Geometric Delay (Average)	0.2 sec		
Stop-Line Delay (Average)	0.0 sec		
Ave. Queue Storage Ratio (Worst Lane)	0.00		
Total Effective Stops	6 veh/h		7 pers/h
Effective Stop Rate	0.02	0.02 per km	0.02
Proportion Queued	0.01		0.01
Performance Index	3.4		3.4
Cost (Total)	265.99 \$/h	0.81 \$/km	265.99 \$/h
Fuel Consumption (Total)	55.8 L/h	170.1 mL/km	
Fuel Economy	17.0 L/100km		
Carbon Dioxide (Total)	137.7 kg/h	419.3 g/km	
Hydrocarbons (Total)	0.010 kg/h	0.031 g/km	
Carbon Monoxide (Total)	0.194 kg/h	0.591 g/km	
NOx (Total)	0.693 kg/h	2.112 g/km	

Network Model Variability Index (Iterations 3 to N): 0.0 %

Number of Iterations: 5 (Maximum: 10)

Largest change in Lane Degrees of Saturation or Queue Storage Ratios for the last three Network Iterations: 0.0% 0.0% 0.0%

Network Level of Service (LOS) Method: SIDRA Speed Efficiency.

Software Setup used: Standard Left.

Degree of Saturation

Use the button below to open or close all popup boxes. Click value labels to open selected ones.
Click and drag popup boxes to move to preferred positions.

Open All Popups

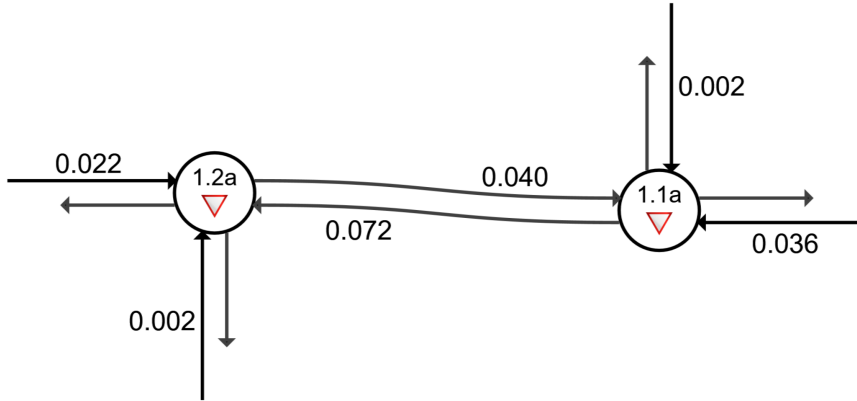

Colour code based on Degree of Saturation

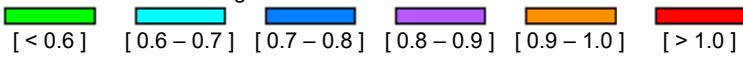

Network: N01 [PM 2025 (Network Folder: Base 2025)]

PM 2025

Network Category: Base Year

Network Layout

Layout pictures are schematic functional drawings reflecting input data. They are not design drawings.

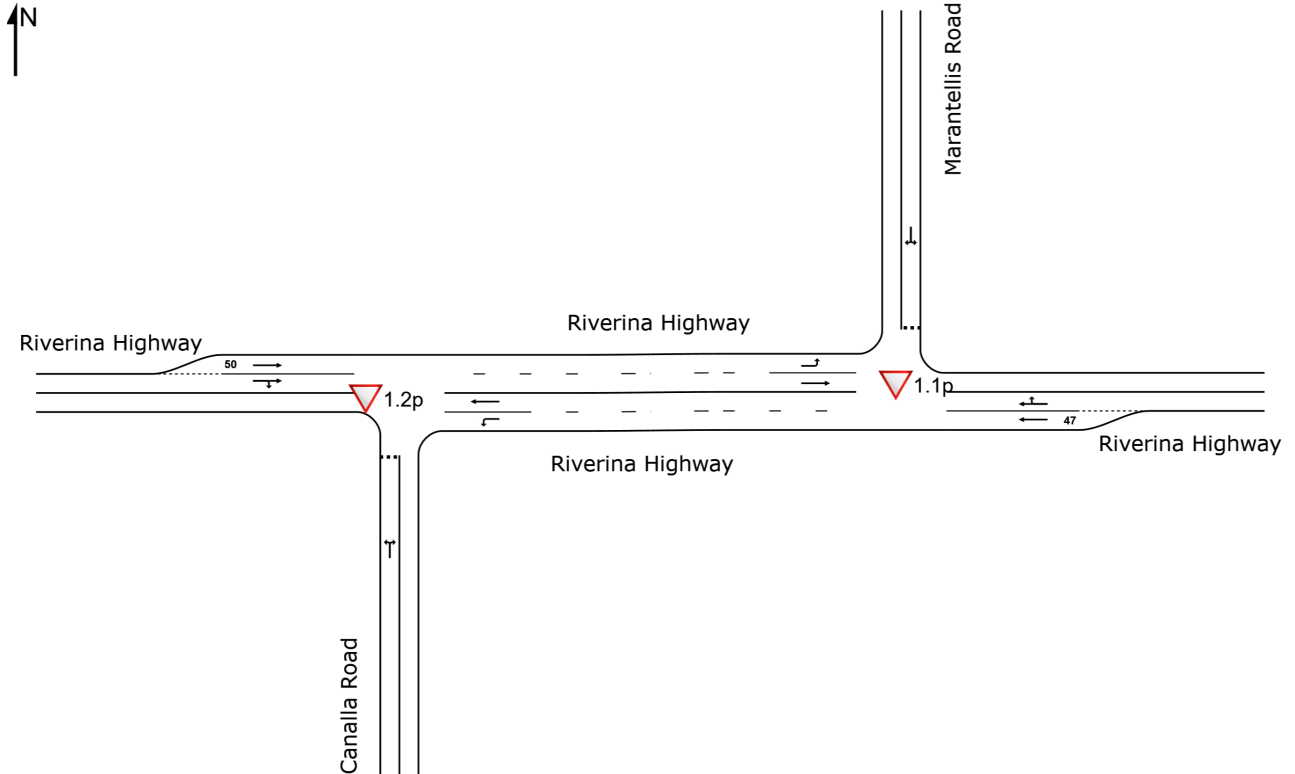

Network Flows - Demand

Use the button below to open or close all popup boxes. Click value labels to open selected ones. Click and drag popup boxes to move to preferred positions.

Open All Popups

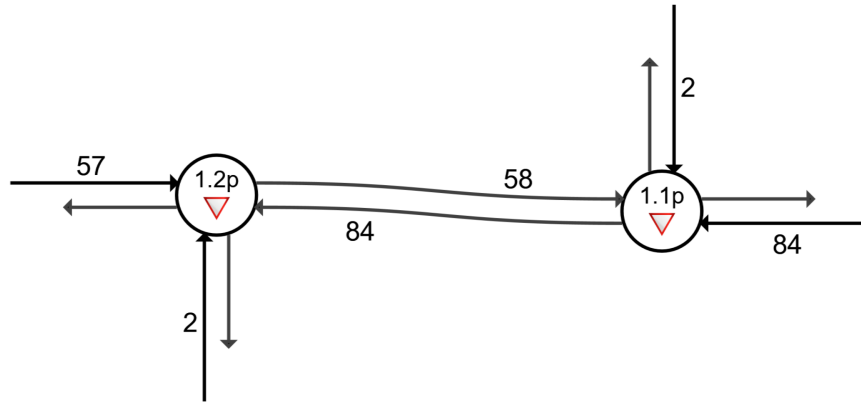

Approach Level of Service

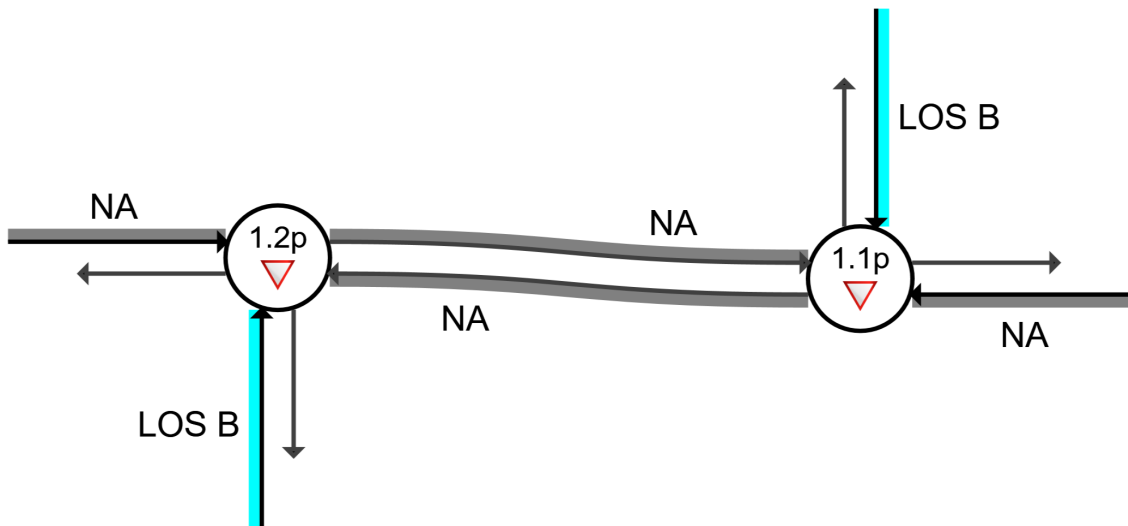

Colour code based on Level of Service

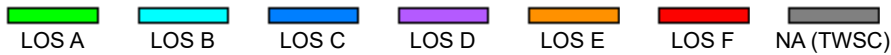

Site Level of Service (LOS) Method: Delay (SIDRA). Site LOS Method is specified in the Network Data dialog (Network tab).

NA (TWSC): Level of Service is not defined for major road approaches or the intersection as a whole for Two-Way Sign Control (HCM LOS rule).

Delay Model: SIDRA Standard (Geometric Delay is included).

Network Performance - Hourly Values			
Performance Measure	Vehicles	Per Unit Distance	Persons
Network Level of Service (LOS)	LOS A		
Speed Efficiency	0.99		
Travel Time Index	9.85		
Congestion Coefficient	1.01		
Travel Speed (Average)	97.9 km/h		97.9 km/h
Travel Distance (Total)	323.6 veh-km/h		388.3 pers-km/h
Travel Time (Total)	3.3 veh-h/h		4.0 pers-h/h
Desired Speed (Program)	99.3 km/h		
Demand Flows (Total for all Sites)	287 veh/h		345 pers/h
Arrival Flows (Total for all Sites)	287 veh/h		345 pers/h
Demand Flows (Entry Total)	145 veh/h		
Midblock Inflows (Total)	1 veh/h		
Midblock Outflows (Total)	0 veh/h		
Percent Heavy Vehicles (Demand)	22.0 %		
Percent Heavy Vehicles (Arrival)	22.0 %		
Degree of Saturation	0.059		
Control Delay (Total)	0.02 veh-h/h		0.02 pers-h/h
Control Delay (Average)	0.2 sec		0.2 sec
Control Delay (Worst Lane)	11.2 sec		
Control Delay (Worst Movement)	13.8 sec		13.8 sec
Geometric Delay (Average)	0.2 sec		
Stop-Line Delay (Average)	0.0 sec		
Ave. Queue Storage Ratio (Worst Lane)	0.00		
Total Effective Stops	5 veh/h		6 pers/h
Effective Stop Rate	0.02	0.02 per km	0.02
Proportion Queued	0.01		0.01
Performance Index	3.3		3.3
Cost (Total)	256.39 \$/h	0.79 \$/km	256.39 \$/h
Fuel Consumption (Total)	52.7 L/h	162.7 mL/km	
Fuel Economy	16.3 L/100km		
Carbon Dioxide (Total)	129.5 kg/h	400.2 g/km	
Hydrocarbons (Total)	0.010 kg/h	0.031 g/km	
Carbon Monoxide (Total)	0.197 kg/h	0.607 g/km	
NOx (Total)	0.633 kg/h	1.956 g/km	

Network Model Variability Index (Iterations 3 to N): 0.0 %

Number of Iterations: 5 (Maximum: 10)

Largest change in Lane Degrees of Saturation or Queue Storage Ratios for the last three Network Iterations: 0.0% 0.0% 0.0%

Network Level of Service (LOS) Method: SIDRA Speed Efficiency.

Software Setup used: Standard Left.

Degree of Saturation

Use the button below to open or close all popup boxes. Click value labels to open selected ones.
Click and drag popup boxes to move to preferred positions.

Open All Popups

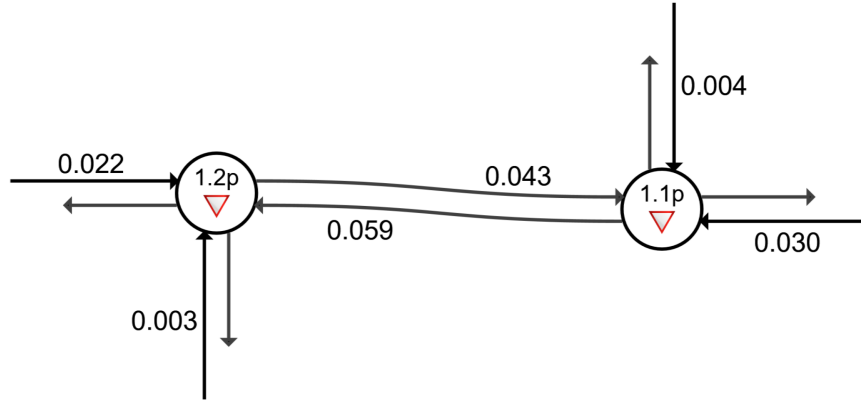

Colour code based on Degree of Saturation

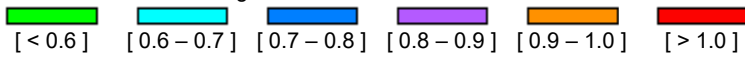

■ Network: N01+ [AM 2026 (Network Folder: Construction 2026)]

AM 2026

Network Category: Future Conditions 1

Design Life Analysis (Final Year): Results for 1 years

Network Layout

Layout pictures are schematic functional drawings reflecting input data. They are not design drawings.

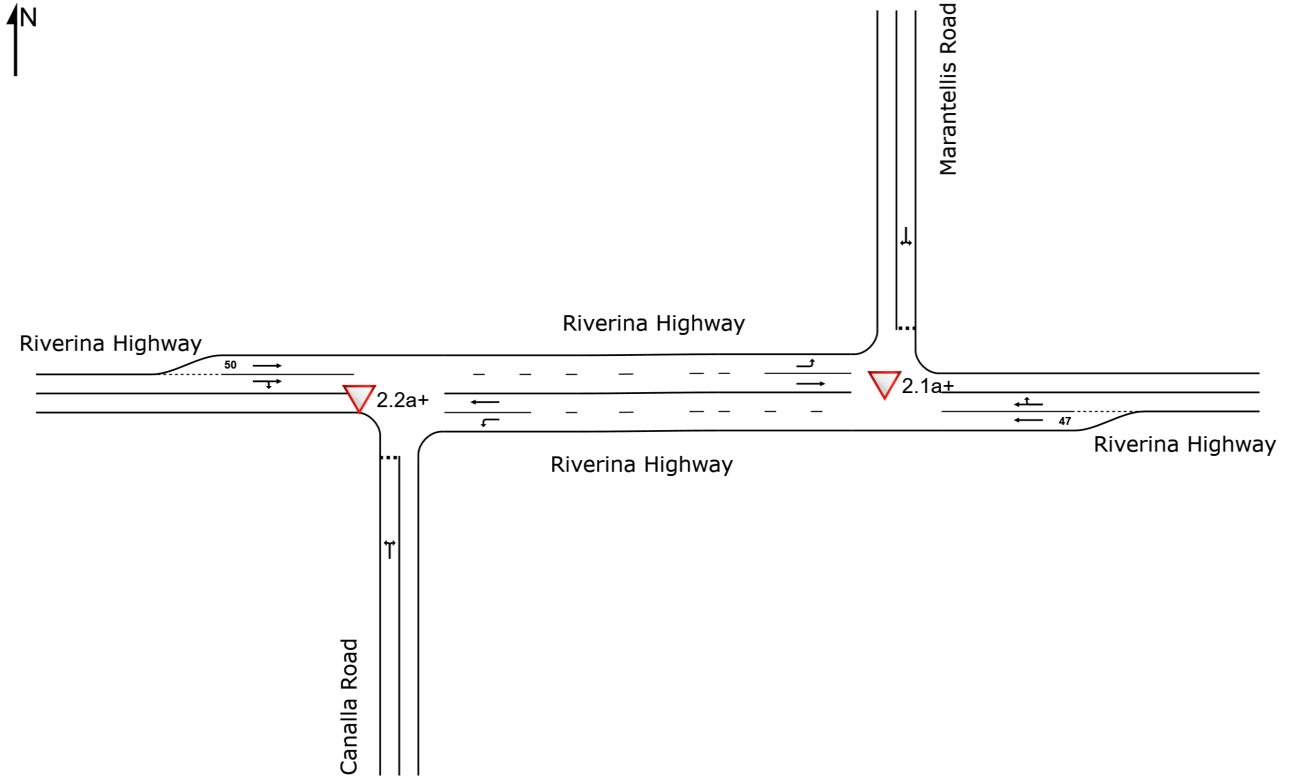

Network Flows - Demand

Use the button below to open or close all popup boxes. Click value labels to open selected ones. Click and drag popup boxes to move to preferred positions.

Open All Popups

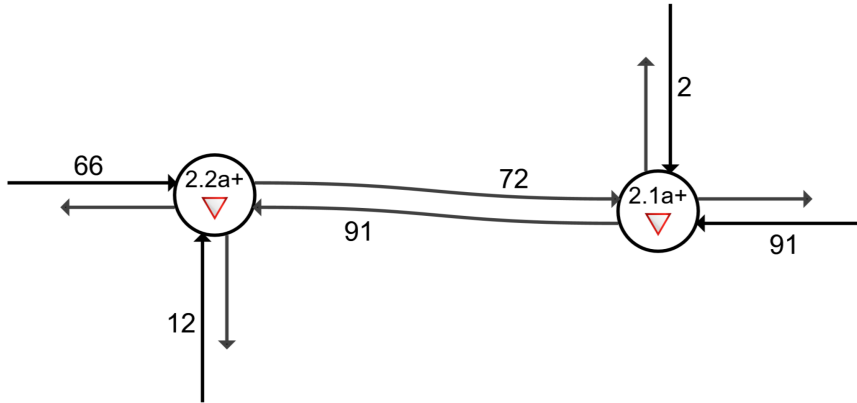

Approach Level of Service

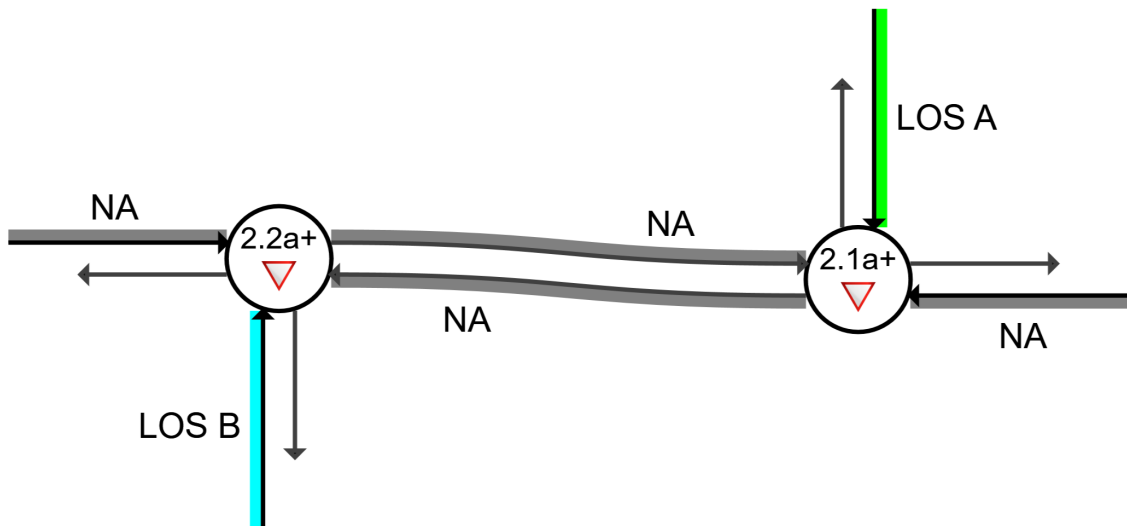

Colour code based on Level of Service

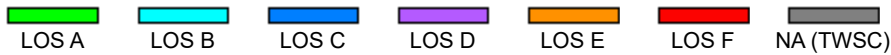

Site Level of Service (LOS) Method: Delay (SIDRA). Site LOS Method is specified in the Network Data dialog (Network tab).

NA (TWSC): Level of Service is not defined for major road approaches or the intersection as a whole for Two-Way Sign Control (HCM LOS rule).

Delay Model: SIDRA Standard (Geometric Delay is included).

Network Performance - Hourly Values			
Performance Measure	Vehicles	Per Unit Distance	Persons
Network Level of Service (LOS)	LOS A		
Speed Efficiency	0.99		
Travel Time Index	9.88		
Congestion Coefficient	1.01		
Travel Speed (Average)	95.0 km/h		90.3 km/h
Travel Distance (Total)	371.8 veh-km/h		488.2 pers-km/h
Travel Time (Total)	3.9 veh-h/h		5.4 pers-h/h
Desired Speed (Program)	96.0 km/h		
Demand Flows (Total for all Sites)	335 veh/h		432 pers/h
Arrival Flows (Total for all Sites)	335 veh/h		432 pers/h
Demand Flows (Entry Total)	171 veh/h		
Midblock Inflows (Total)	0 veh/h		
Midblock Outflows (Total)	0 veh/h		
Percent Heavy Vehicles (Demand)	28.9 %		
Percent Heavy Vehicles (Arrival)	28.9 %		
Degree of Saturation	0.073		
Control Delay (Total)	0.08 veh-h/h		0.18 pers-h/h
Control Delay (Average)	0.9 sec		1.5 sec
Control Delay (Worst Lane)	12.9 sec		
Control Delay (Worst Movement)	14.0 sec		14.0 sec
Geometric Delay (Average)	0.7 sec		
Stop-Line Delay (Average)	0.2 sec		
Ave. Queue Storage Ratio (Worst Lane)	0.00		
Total Effective Stops	29 veh/h		37 pers/h
Effective Stop Rate	0.09	0.08 per km	0.09
Proportion Queued	0.02		0.02
Performance Index	4.2		
Cost (Total)	369.23 \$/h	0.99 \$/km	369.23 \$/h
Fuel Consumption (Total)	81.4 L/h	218.8 mL/km	
Fuel Economy	21.9 L/100km		
Carbon Dioxide (Total)	200.7 kg/h	540.0 g/km	
Hydrocarbons (Total)	0.013 kg/h	0.034 g/km	
Carbon Monoxide (Total)	0.228 kg/h	0.614 g/km	
NOx (Total)	1.180 kg/h	3.175 g/km	

Network Model Variability Index (Iterations 3 to N): 0.0 %

Number of Iterations: 5 (Maximum: 10)

Largest change in Lane Degrees of Saturation or Queue Storage Ratios for the last three Network Iterations: 0.0% 0.0% 0.0%

Network Level of Service (LOS) Method: SIDRA Speed Efficiency.

Software Setup used: Standard Left.

Degree of Saturation

Use the button below to open or close all popup boxes. Click value labels to open selected ones.
Click and drag popup boxes to move to preferred positions.

Open All Popups

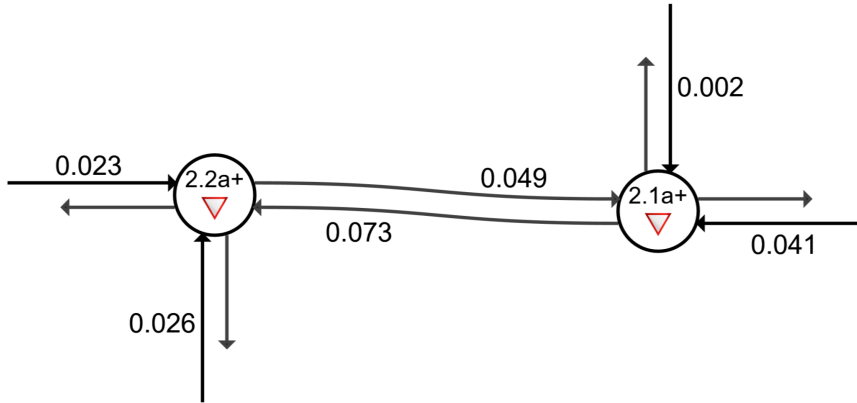

Colour code based on Degree of Saturation

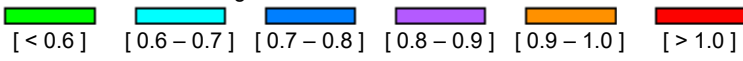

Network: N01+ [PM 2026 (Network Folder: Construction 2026)]

PM 2026

Network Category: Future Conditions 1

Design Life Analysis (Final Year): Results for 1 years

Network Layout

Layout pictures are schematic functional drawings reflecting input data. They are not design drawings.

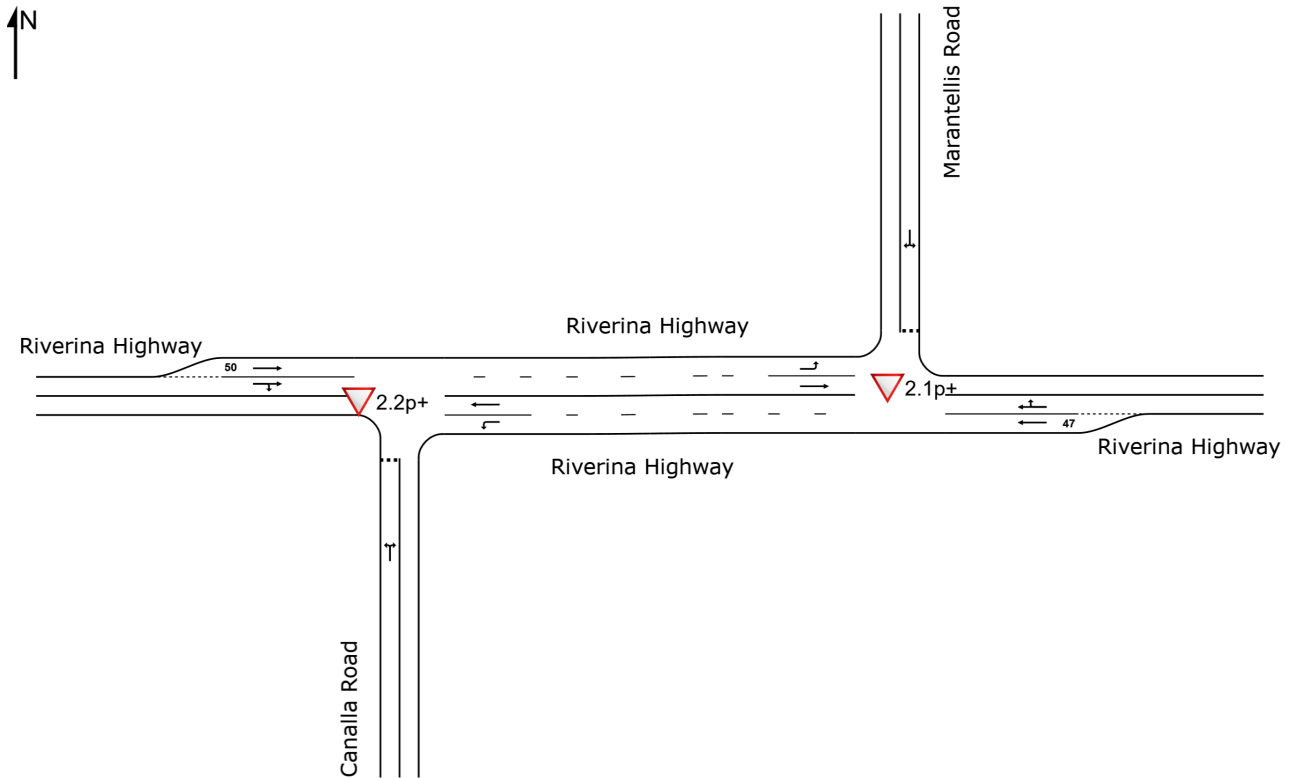

Network Flows - Demand

Use the button below to open or close all popup boxes. Click value labels to open selected ones.
Click and drag popup boxes to move to preferred positions.

Open All Popups

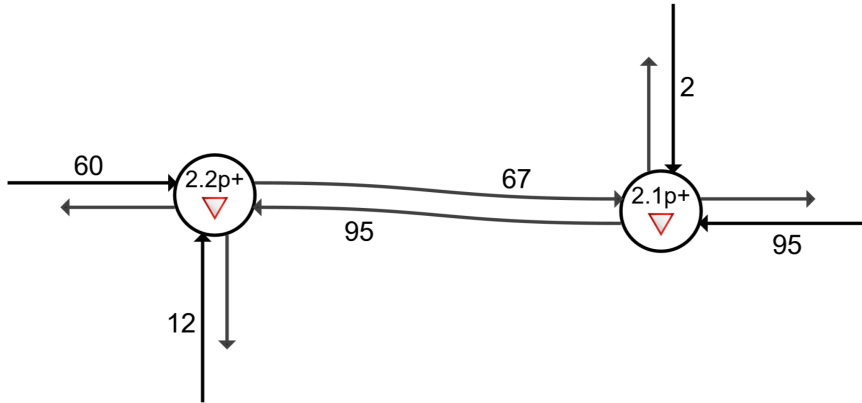

Approach Level of Service

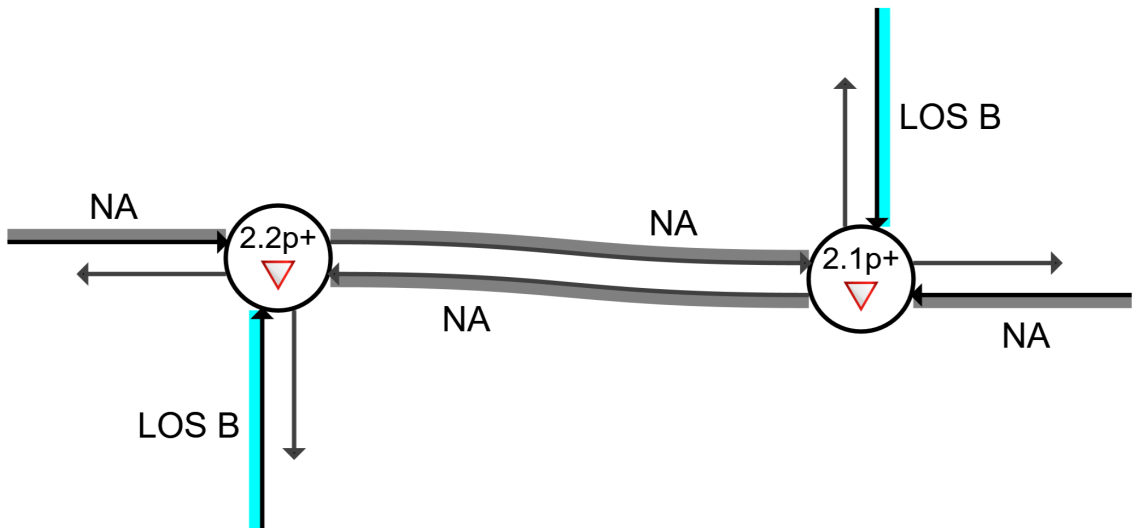

Colour code based on Level of Service

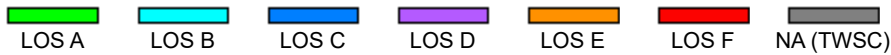

Site Level of Service (LOS) Method: Delay (SIDRA). Site LOS Method is specified in the Network Data dialog (Network tab).

NA (TWSC): Level of Service is not defined for major road approaches or the intersection as a whole for Two-Way Sign Control (HCM LOS rule).

Delay Model: SIDRA Standard (Geometric Delay is included).

Network Performance - Hourly Values			
Performance Measure	Vehicles	Per Unit Distance	Persons
Network Level of Service (LOS)	LOS A		
Speed Efficiency	0.98		
Travel Time Index	9.80		
Congestion Coefficient	1.02		
Travel Speed (Average)	94.3 km/h		89.7 km/h
Travel Distance (Total)	367.0 veh-km/h		482.5 pers-km/h
Travel Time (Total)	3.9 veh-h/h		5.4 pers-h/h
Desired Speed (Program)	96.1 km/h		
Demand Flows (Total for all Sites)	329 veh/h		426 pers/h
Arrival Flows (Total for all Sites)	329 veh/h		426 pers/h
Demand Flows (Entry Total)	168 veh/h		
Midblock Inflows (Total)	1 veh/h		
Midblock Outflows (Total)	0 veh/h		
Percent Heavy Vehicles (Demand)	26.1 %		
Percent Heavy Vehicles (Arrival)	26.1 %		
Degree of Saturation	0.060		
Control Delay (Total)	0.08 veh-h/h		0.18 pers-h/h
Control Delay (Average)	0.9 sec		1.5 sec
Control Delay (Worst Lane)	12.9 sec		
Control Delay (Worst Movement)	14.2 sec		14.2 sec
Geometric Delay (Average)	0.8 sec		
Stop-Line Delay (Average)	0.1 sec		
Ave. Queue Storage Ratio (Worst Lane)	0.00		
Total Effective Stops	29 veh/h		37 pers/h
Effective Stop Rate	0.09	0.08 per km	0.09
Proportion Queued	0.02		0.02
Performance Index	4.2		4.2
Cost (Total)	365.00 \$/h	0.99 \$/km	365.00 \$/h
Fuel Consumption (Total)	80.3 L/h	218.7 mL/km	
Fuel Economy	21.9 L/100km		
Carbon Dioxide (Total)	197.8 kg/h	538.9 g/km	
Hydrocarbons (Total)	0.013 kg/h	0.035 g/km	
Carbon Monoxide (Total)	0.232 kg/h	0.631 g/km	
NOx (Total)	1.162 kg/h	3.167 g/km	

Network Model Variability Index (Iterations 3 to N): 0.0 %

Number of Iterations: 5 (Maximum: 10)

Largest change in Lane Degrees of Saturation or Queue Storage Ratios for the last three Network Iterations: 0.0% 0.0% 0.0%

Network Level of Service (LOS) Method: SIDRA Speed Efficiency.

Software Setup used: Standard Left.

Degree of Saturation

Use the button below to open or close all popup boxes. Click value labels to open selected ones.
Click and drag popup boxes to move to preferred positions.

Open All Popups

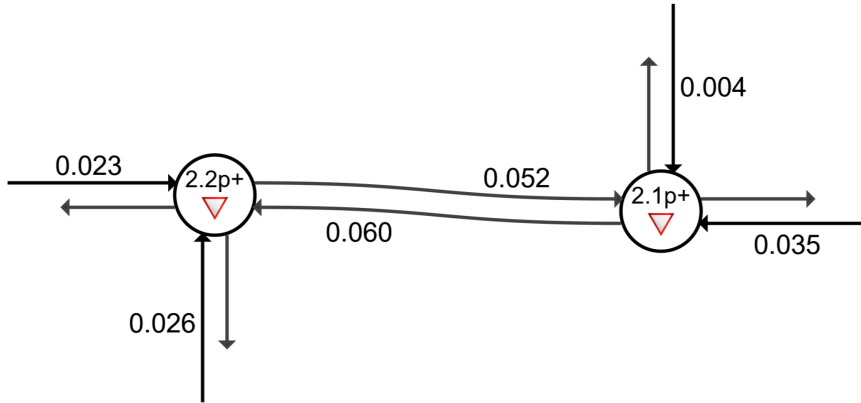

Colour code based on Degree of Saturation

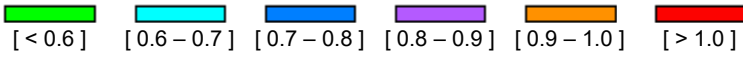

■ Network: N01+ [AM 2036 (Network Folder: Post development 2036)]

AM 2036

Network Category: Future Conditions 2

Design Life Analysis (Final Year): Results for 11 years

Network Layout

Layout pictures are schematic functional drawings reflecting input data. They are not design drawings.

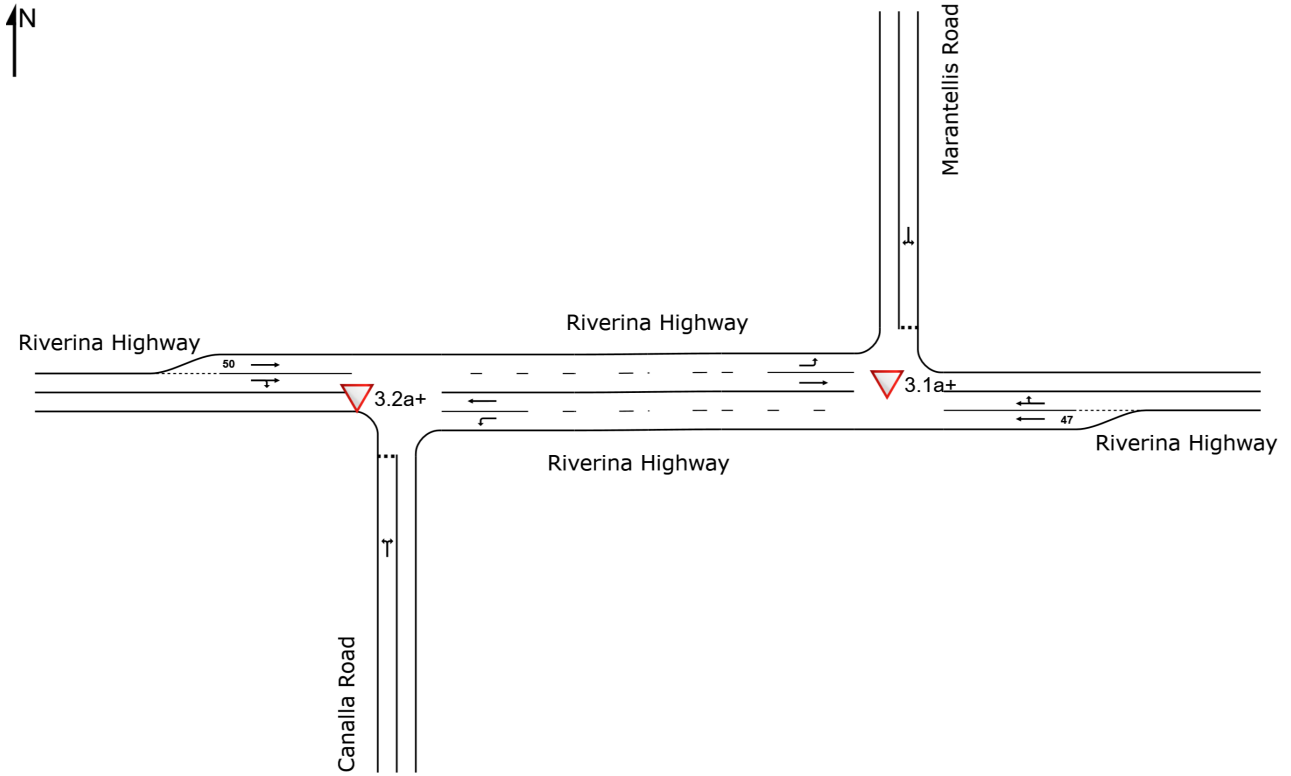

Network Flows - Demand

Use the button below to open or close all popup boxes. Click value labels to open selected ones. Click and drag popup boxes to move to preferred positions.

Open All Popups

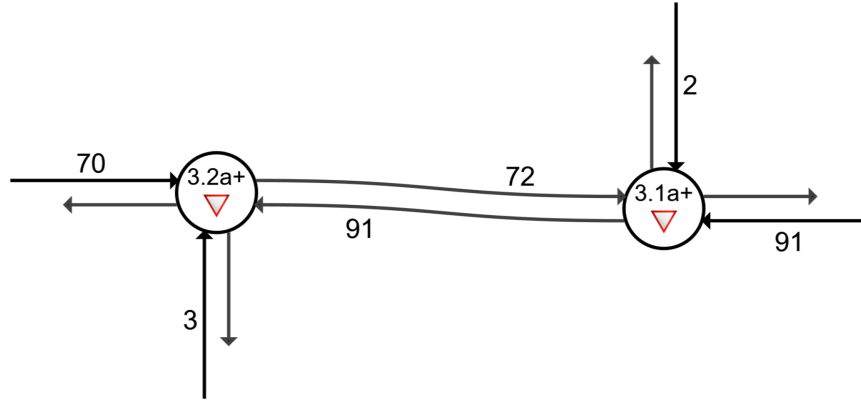

Approach Level of Service

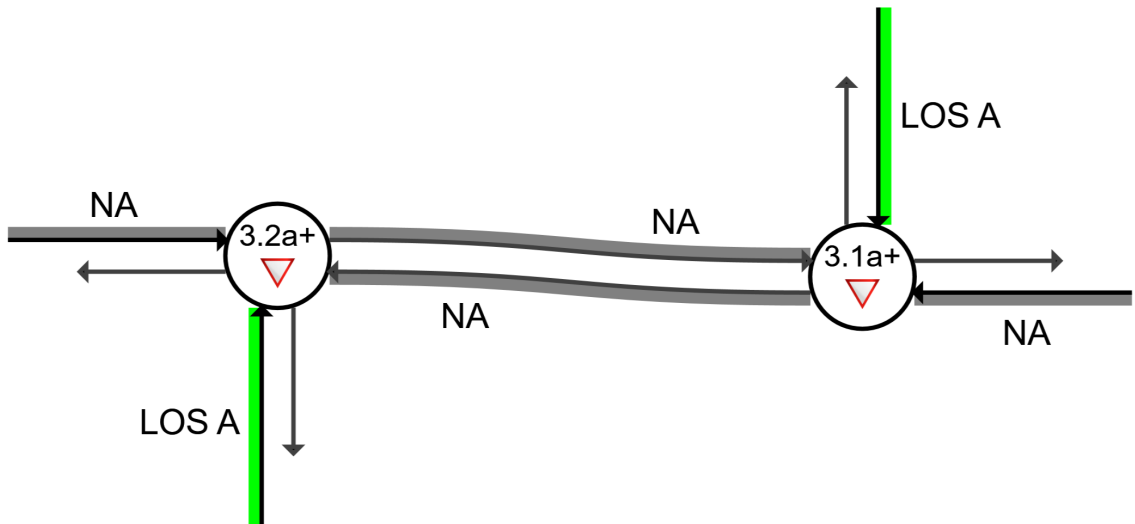

Colour code based on Level of Service

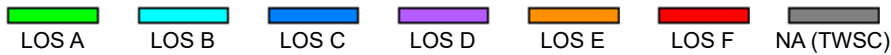

Site Level of Service (LOS) Method: Delay (SIDRA). Site LOS Method is specified in the Network Data dialog (Network tab).

NA (TWSC): Level of Service is not defined for major road approaches or the intersection as a whole for Two-Way Sign Control (HCM LOS rule).

Delay Model: SIDRA Standard (Geometric Delay is included).

Network Performance - Hourly Values			
Performance Measure	Vehicles	Per Unit Distance	Persons
Network Level of Service (LOS)	LOS A		
Speed Efficiency	1.00		
Travel Time Index	9.96		
Congestion Coefficient	1.00		
Travel Speed (Average)	98.4 km/h		98.4 km/h
Travel Distance (Total)	370.5 veh-km/h		444.6 pers-km/h
Travel Time (Total)	3.8 veh-h/h		4.5 pers-h/h
Desired Speed (Program)	98.8 km/h		
Demand Flows (Total for all Sites)	331 veh/h		397 pers/h
Arrival Flows (Total for all Sites)	331 veh/h		397 pers/h
Demand Flows (Entry Total)	168 veh/h		
Midblock Inflows (Total)	0 veh/h		
Midblock Outflows (Total)	0 veh/h		
Percent Heavy Vehicles (Demand)	24.9 %		
Percent Heavy Vehicles (Arrival)	24.9 %		
Degree of Saturation	0.081		
Control Delay (Total)	0.02 veh-h/h		0.03 pers-h/h
Control Delay (Average)	0.3 sec		0.3 sec
Control Delay (Worst Lane)	8.6 sec		
Control Delay (Worst Movement)	8.9 sec		8.9 sec
Geometric Delay (Average)	0.2 sec		
Stop-Line Delay (Average)	0.0 sec		
Ave. Queue Storage Ratio (Worst Lane)	0.00		
Total Effective Stops	9 veh/h		10 pers/h
Effective Stop Rate	0.03	0.02 per km	0.03
Proportion Queued	0.01		0.01
Performance Index	3.8		3.8
Cost (Total)	299.29 \$/h	0.81 \$/km	299.29 \$/h
Fuel Consumption (Total)	62.8 L/h	169.5 mL/km	
Fuel Economy	17.0 L/100km		
Carbon Dioxide (Total)	154.8 kg/h	417.8 g/km	
Hydrocarbons (Total)	0.011 kg/h	0.031 g/km	
Carbon Monoxide (Total)	0.220 kg/h	0.593 g/km	
NOx (Total)	0.775 kg/h	2.091 g/km	

Network Model Variability Index (Iterations 3 to N): 0.0 %

Number of Iterations: 5 (Maximum: 10)

Largest change in Lane Degrees of Saturation or Queue Storage Ratios for the last three Network Iterations: 0.0% 0.0% 0.0%

Network Level of Service (LOS) Method: SIDRA Speed Efficiency.

Software Setup used: Standard Left.

Degree of Saturation

Use the button below to open or close all popup boxes. Click value labels to open selected ones.
Click and drag popup boxes to move to preferred positions.

Open All Popups

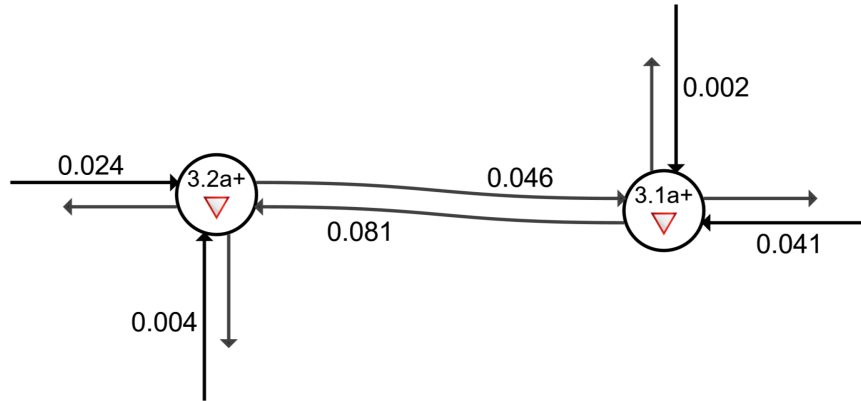

Colour code based on Degree of Saturation

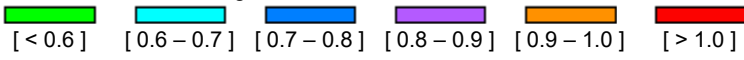

Network: N01+ [PM 2036 (Network Folder: Post development 2036)]

PM 2036

Network Category: Future Conditions 2

Design Life Analysis (Final Year): Results for 11 years

Network Layout

Layout pictures are schematic functional drawings reflecting input data. They are not design drawings.

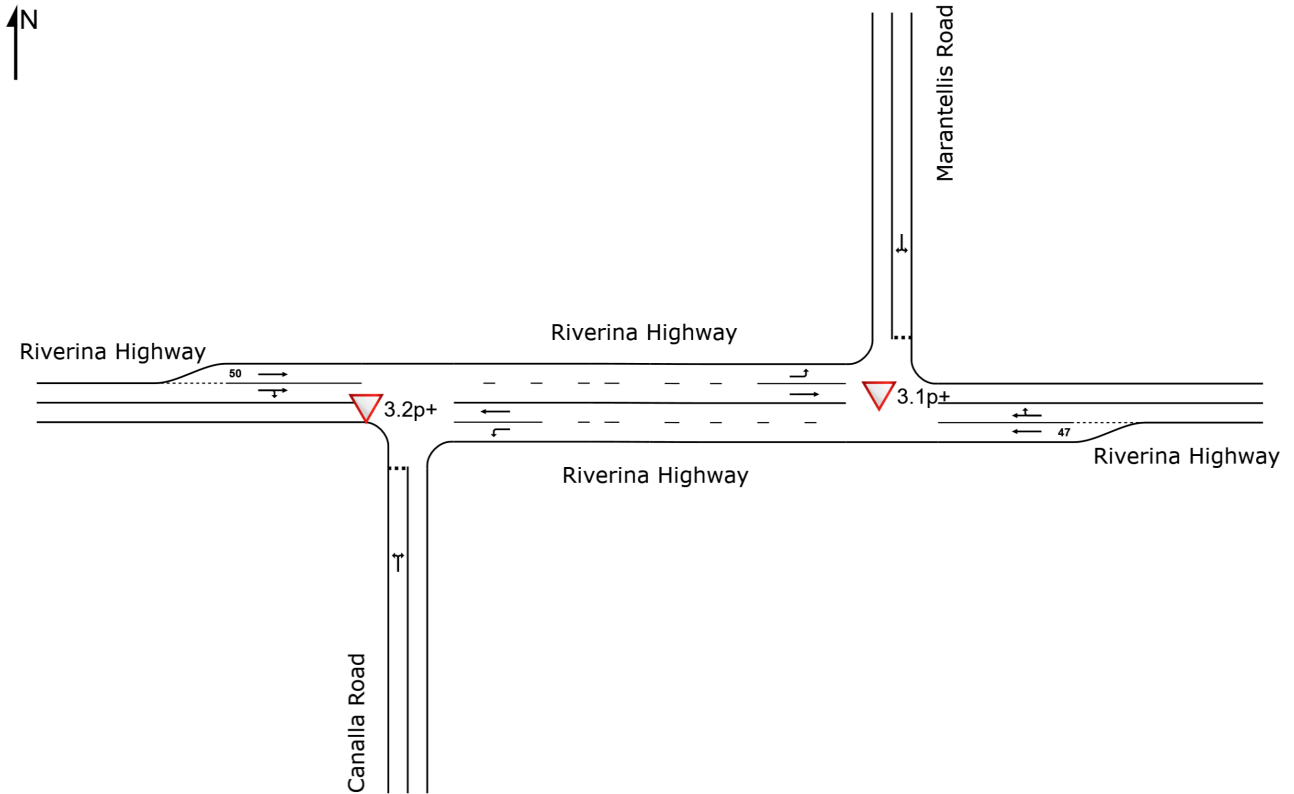

Network Flows - Demand

Use the button below to open or close all popup boxes. Click value labels to open selected ones.
Click and drag popup boxes to move to preferred positions.

Open All Popups

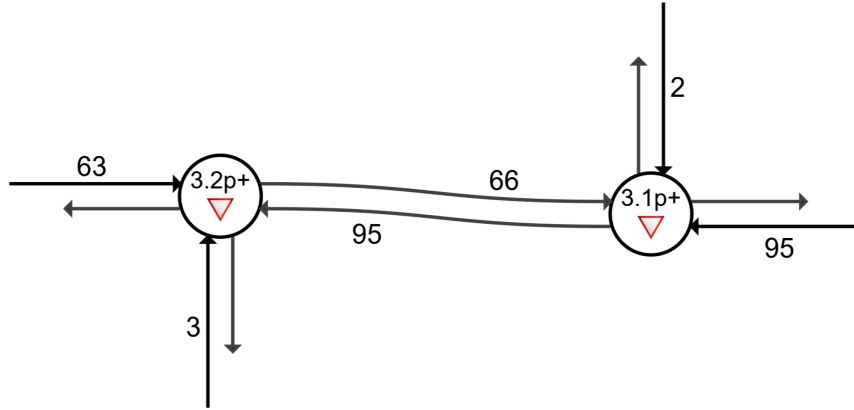

Approach Level of Service

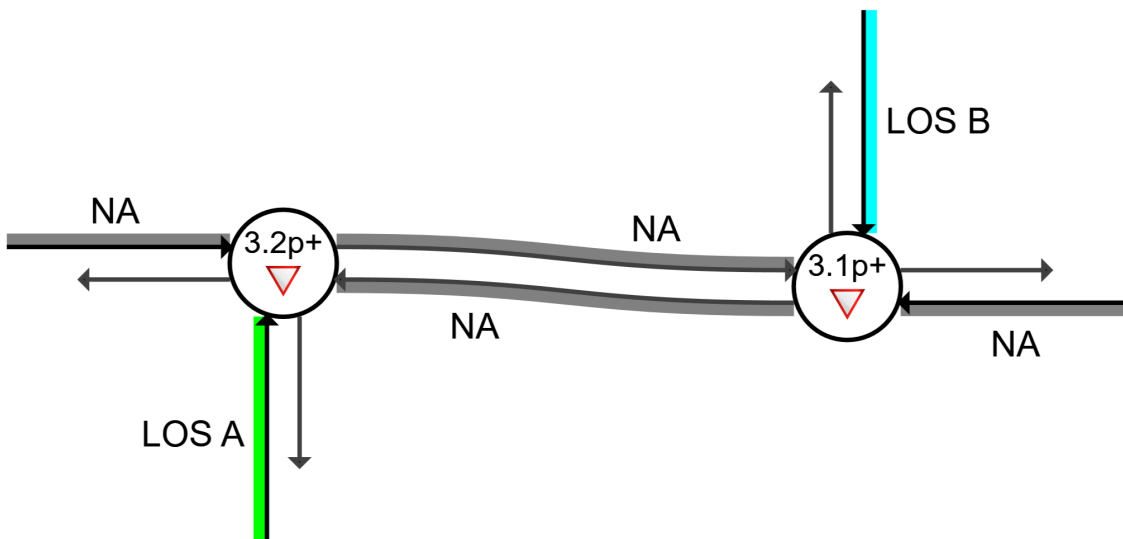

Colour code based on Level of Service

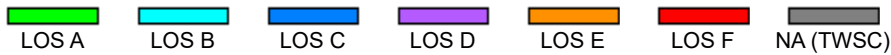

Site Level of Service (LOS) Method: Delay (SIDRA). Site LOS Method is specified in the Network Data dialog (Network tab).

NA (TWSC): Level of Service is not defined for major road approaches or the intersection as a whole for Two-Way Sign Control (HCM LOS rule).

Delay Model: SIDRA Standard (Geometric Delay is included).

Network Performance - Hourly Values			
Performance Measure	Vehicles	Per Unit Distance	Persons
Network Level of Service (LOS)	LOS A		
Speed Efficiency	0.99		
Travel Time Index	9.88		
Congestion Coefficient	1.01		
Travel Speed (Average)	97.9 km/h		97.9 km/h
Travel Distance (Total)	365.2 veh-km/h		438.3 pers-km/h
Travel Time (Total)	3.7 veh-h/h		4.5 pers-h/h
Desired Speed (Program)	98.9 km/h		
Demand Flows (Total for all Sites)	325 veh/h		390 pers/h
Arrival Flows (Total for all Sites)	325 veh/h		390 pers/h
Demand Flows (Entry Total)	164 veh/h		
Midblock Inflows (Total)	1 veh/h		
Midblock Outflows (Total)	0 veh/h		
Percent Heavy Vehicles (Demand)	21.7 %		
Percent Heavy Vehicles (Arrival)	21.7 %		
Degree of Saturation	0.066		
Control Delay (Total)	0.03 veh-h/h		0.03 pers-h/h
Control Delay (Average)	0.3 sec		0.3 sec
Control Delay (Worst Lane)	11.4 sec		
Control Delay (Worst Movement)	14.0 sec		14.0 sec
Geometric Delay (Average)	0.3 sec		
Stop-Line Delay (Average)	0.0 sec		
Ave. Queue Storage Ratio (Worst Lane)	0.00		
Total Effective Stops	8 veh/h		10 pers/h
Effective Stop Rate	0.03	0.02 per km	0.03
Proportion Queued	0.01		0.01
Performance Index	3.8		3.8
Cost (Total)	288.49 \$/h	0.79 \$/km	288.49 \$/h
Fuel Consumption (Total)	59.3 L/h	162.3 mL/km	
Fuel Economy	16.2 L/100km		
Carbon Dioxide (Total)	145.7 kg/h	398.8 g/km	
Hydrocarbons (Total)	0.011 kg/h	0.031 g/km	
Carbon Monoxide (Total)	0.223 kg/h	0.610 g/km	
NOx (Total)	0.707 kg/h	1.936 g/km	

Network Model Variability Index (Iterations 3 to N): 0.0 %

Number of Iterations: 5 (Maximum: 10)

Largest change in Lane Degrees of Saturation or Queue Storage Ratios for the last three Network Iterations: 0.0% 0.0% 0.0%

Network Level of Service (LOS) Method: SIDRA Speed Efficiency.

Software Setup used: Standard Left.

Degree of Saturation

Use the button below to open or close all popup boxes. Click value labels to open selected ones.
Click and drag popup boxes to move to preferred positions.

Open All Popups

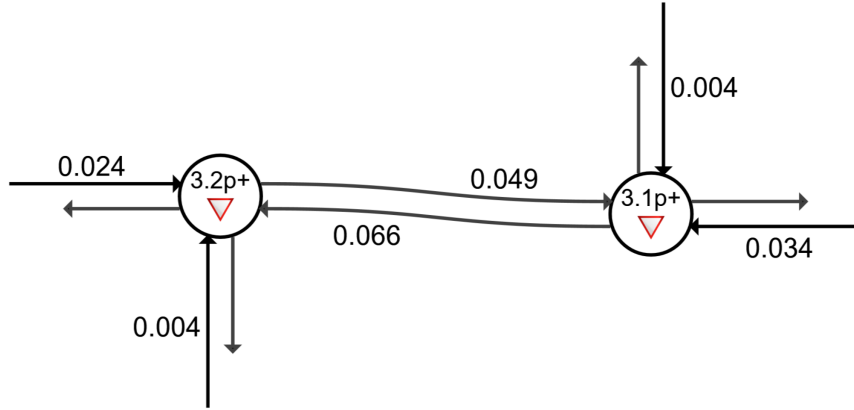

Colour code based on Degree of Saturation

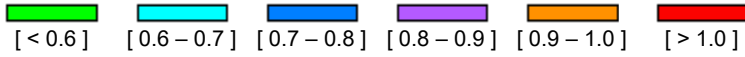

APPENDIX C

DEVELOPMENT SITE PLAN





Detail of Intersection

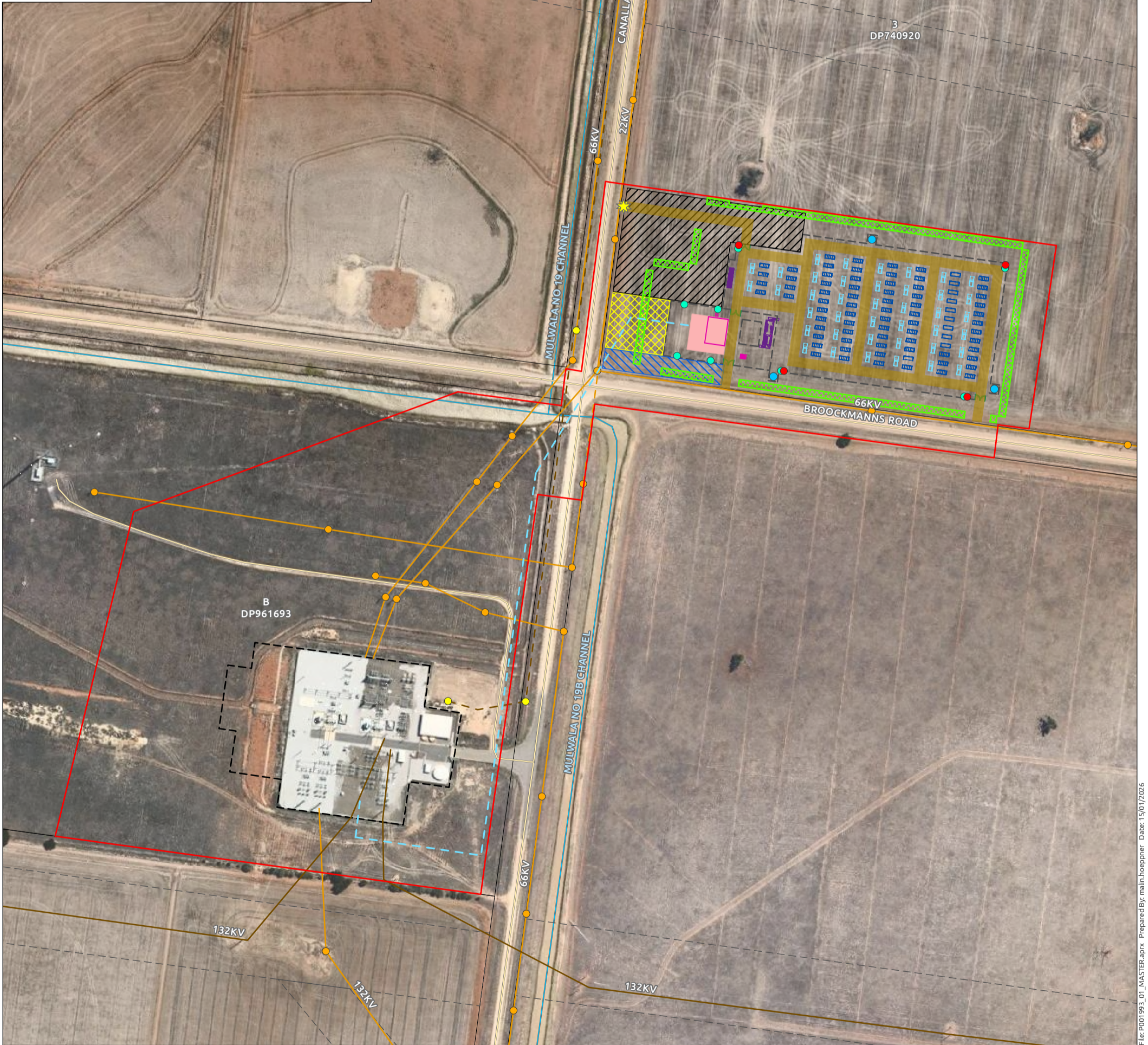

Legend	
	Development Site
	Primary Site Access (Heavy Vehicle)
	Lot
	Road
	Watercourse
	Existing Substation
	Existing Easement
	Essential Energy OH
	Essential Energy UG
	Transgrid OH
	Transgrid Optic Fibre
●	Essential Energy Pole
●	Transgrid Pit
	Substation Switch Area
	Internal Road
	Car Parking
	Laydown
	Site Ofces
	BESS Substation
	BESS Buildings
	Battery
	Inverter
	Gate
	Fence
	Screening Vegetation
	Proposed UG Connection line
●	Watertank
●	CCTV Mast
●	BESS Lighting Mast

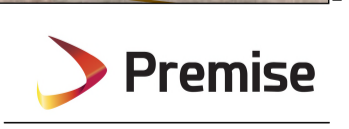

Figure 2
Proposed Development Detail

Sources: © State of NSW, Department of Customer Services, Spatial Services 2025
Grassroots Development 2024 (Nearmap 2025)
File: P001993_01_MASTER.aprx Prepared By: malin.hoepfner Date: 15/07/2026

APPENDIX D

TFNSW REQUIREMENTS



18 January 2024

TfNSW reference: WST23/00200/01

SLR Consulting Australia
Level 16
175 Eagle Street
BRISBANE QLD 4000

Attention: Ursula McInnes

**Pre-SEARs; Finley Battery Energy Storage System
Lot 3, DP 740920, Riverina Highway (HW20), Finley**

Thank you for writing to Transport for NSW (TfNSW) seeking preliminary comments in relation to the Finley Battery Energy Storage System (BESS).

TfNSW has reviewed the information prepared for Gransolar Development Australia and provides advice in **Attachment A** to assist you in the preparation of documentation in support of the proposal for future submission to the Department of Planning and Environment.

If you have any questions or wish to discuss this matter further, please contact Glen Hanchard on 1300 019 680 or email development.west@transport.nsw.gov.au.

Yours faithfully,



Andrew McIntyre
Manager Development Services
Community and Place | Region West
Regional & Outer Metropolitan Division

OFFICIAL

Pre-SEARs; Finley Battery Energy Storage System

Context

- The project proposes construction, operation and decommissioning of a Battery Energy Storage System (BESS) with a capacity of 100 Megawatts connecting via transmission line to the existing Finley 132/66KV TS Substation operated by TransGrid.
- The project is proposed to be constructed and operated on Lot 3, DP 740920. Access has not been completely identified however is likely to be from Riverina Highway. The Riverina Highway is a State classified road.

TfNSW advice

The Environmental Impact Study to be submitted as part of the environmental planning process will need to include a Traffic Impact Assessment (TIA) to address the impact of traffic generation on the public road network and measures employed to ensure traffic efficiency and road safety during construction, operation and decommissioning of the project.

The requested TIA needs to be tailored to the scope of the proposed development and include, but not be limited to, the following:

- Traffic volumes including:
 - Existing background traffic,
 - Project-related traffic for each phase or stage of the project,
 - Projected cumulative traffic at commencement of operation, and a 10-year horizon post-commencement.
- Traffic characteristics including:
 - Number and ratio of heavy vehicles to light vehicles,
 - Peak times for existing traffic,
 - Peak times for project-related traffic including commuter periods,
 - Proposed hours for transportation and haulage,
 - Interactions between existing and project-related traffic.
- Capacity analysis using *Austrroads Guide to Road Design* at intersections with classified (State) road/s, and where relevant, analysis of any other intersections along the proposed transport route/s.
- Heavy vehicle and OSOM routes:
 - Concept-level route analysis based on high-level 3D swept path drawings to identify the return routes for OSOM movements and indicate locations where civil works are needed and indicative pinch points.

OFFICIAL

- The TIA is required to include details of OSOM movements, including volumes, times for OSOM movements to occur and identify the location of pull-over bays / rest areas on OSOM routes (including GPS coordinates) and confirmation such facilities can physically accommodate (in terms of size, width and accessibility) the largest OSOM vehicle.
- Undertake a logistics route analysis that includes:
 - Details of the road geometry and alignment along the identified transport route/s, including existing formations, crossings, bridges, intersection treatments and any identified hazards, including:
 - Available sight distances at the site access and nearby intersections and any constraint to achieving the required sight distance for the posted speed limit.
 - An assessment of turn treatment warrants in accordance with *Austroads Guide to Traffic Management Part 6* and *Austroads Guide to Road Design Part 4A* for intersections on identified transport route/s, identifying the existence of the minimum basic turn treatments and addressing the need for any warranted higher order treatments.
 - Bridge Assessments for any at risk bridges on the classified road network due to dimensions and weight of OSOM vehicles.
 - Swept path analysis demonstrating the largest design vehicle can enter and leave the development, and simultaneously pass through intersections along the proposed transport route/s.

The design vehicle templates used in the swept path analysis software are also requested in order for TfNSW to review the performance within the software (e.g. Autodesk Vehicle Tracking or Transoft AutoTURN).
 - Highlighting each at-risk road structures that the haulage route crosses including bridges, traffic signals, signage, major culverts, and minor culverts that may not meet the desirable cover to cater for proposed axle loads.
 - National Heavy Vehicle Regulator (NHVR) approved routes identified on Restricted Access Maps (RAV MAP) are to be utilised for proposed heavy vehicle routes. Please note NHVR permits do not cover civil works required along any proposed OSOM route. Any works required on OSOM routes must be included within the scope of works in the SSD to ensure the development is constructable.
- Identify and provide the following measurements parameters of OSOM components / materials to be moved:
 - Types and numbers of OSOM vehicles proposed to be used for the project.
 - Overall combination load length, width, height and mass for components and nominated vehicles.
 - Maximum component length, widths and heights (including clearance to overhead obstructions such as structures, utilities and vegetation),
 - Wheelbase dimensions,
 - Maximum trailer articulation angle(s),
 - Minimum overhang heights above the road surface,
 - Axle loads and axle group loads in terms of both tonnes and Equivalent Standard Axles (refer to *Austroads Guide to Pavement Technology*).
- Cumulative impacts:
 - Identify and assess implications of any road and rail projects that may occur during OSOM movements on proposed OSOM routes.

OFFICIAL

OFFICIAL

- Identify projects that will have overlapping construction periods and assess the cumulative traffic impacts with emphasis on the following:
 - Cumulative traffic (light and heavy vehicles) impacts generated from construction workforces (origin-destination routes, access, AM/PM peak) and where they overlap with other projects.
 - Cumulative impacts and consideration in relation to timing of movements of OSOMs and their interaction with OSOM movements generated by other projects. Please note, given the high number of renewable energy and other large scale projects requiring haulage of OSOM components, restrictions, and limitations on OSOM movements may be imposed. In this regard, it is requested you engage earlier with TfNSW's Freight Branch – Special Permits team to discuss access needs and timing.
- Identify accommodation (and transport) needs and facilities available within the local region to service project staff, in addition to understanding the cumulative impacts of concurrent accommodation (and transport) needs of staff from other projects. Details of measures employed to promote and enforce safe commuter traffic movements are to be included.
- Road safety assessment of haulage route/s.
 - Where road safety concerns are identified at specific locations on haulage routes, TfNSW suggests the TIA include a targeted Road Safety Audit undertaken by suitably qualified persons in accordance with *Austrroads Guidelines*.
- A review of crash data along identified transport route/s for the most recent five year reporting period and an assessment of road safety along the proposed transport route/s considering the safe systems principles adopted under *Future Transport 2056*.
- Project schedule:
 - Hours and days of work, number of shifts and start and end times,
 - Identify the approximate project's targeted construction commencement date/s.
 - Identify the phases and stages of the project, including construction, operation and decommissioning.
- The origins, destinations and routes for:
 - Commuter (employee and contractor) light vehicles and pool vehicles (including. shuttle buses),
 - Heavy (haulage) vehicles,
 - OSOM vehicles.
- Identify the necessary road network infrastructure upgrades that are required to cater for and mitigate the impact of project related traffic on both the local and classified road network for the development (for instance, road widening and/or intersection treatments).
 In this regard, strategic design drawing/s should be submitted with the SSD application for any identified road infrastructure and access upgrades. Any identified road infrastructure upgrades will need to be to the satisfaction of TfNSW and Council. Works must be appropriately designed in accordance with *Austrroads Guide to Road Design* for the existing posted speed limit, including provision of Safe Intersection Sight Distance (SISD).
 Note: The design needs to comply with *TfNSW Strategic design requirements for DAs*. To assist you in preparing the designs, please refer to link below:
<https://roads-waterways.transport.nsw.gov.au/business-industry/partners-suppliers/documents/planning-principles/strategic-design-fact-sheet-02-2022.pdf>
- The layout of the internal road network, parking facilities and infrastructure.

OFFICIAL

OFFICIAL

- Impact on rail corridors and level crossings along transport route/s detailing any proposed interface treatments, where applicable.
- Controls for transport and use of any dangerous goods in accordance with *State Environmental Planning Policy No. 33 – Hazardous and Offensive Development*, the *Australian Dangerous Goods Code* and *AS4452 Storage and Handling of Toxic Substances*.
- A draft Traffic Management Plan (TMP) to be implemented following approval of the EIS, in consultation with relevant Councils and TfNSW. The TMP is to address the construction, operation and decommission phases of the development and prepared and implemented in accordance with *Australian Standard 1742.3* and *Work Health and Safety Regulation 2017*.

The TMP is to identify strategies to manage the impacts of project related traffic, and propose a Driver Code of Conduct for haulage operations to include, but not be limited to:

- A map of the primary transport route/s highlighting critical locations.
 - Identification of local bus operations, including maps of routes/bus stops, and consultation with local bus operators.
 - Safety initiatives for haulage through residential areas and/or school zones.
 - An induction process for vehicle operators and regular toolbox meetings.
 - Consideration of the local climate conditions that may affect road safety during the life of the project (e.g. fog, wet and dry weather, icy road conditions).
 - A public complaint resolution and disciplinary procedure.
 - A complaint resolution and disciplinary procedure.
 - Any proposed temporary measures such a Traffic Guidance Scheme (TGS)
 - Community consultation measures for peak haulage periods
- Ancillary Infrastructure,

Detailed plans identifying the proposed location of any:

 - Project-related infrastructure within and outside of the project boundary.
 - Transmission line infrastructure, or any other project-related structures, within a road reserve. In respect to this matter the following information is required:
 - Overhead clearances,
 - Construction methods,
 - Potential traffic mitigation measures for construction,
 - Location of infrastructure within or adjacent to the road reserve,
 - Excavation or fill requirements adjacent or within road corridors,
 - Access required to construct and maintain the infrastructure, and
 - Permanent or temporary connection/access to classified roads.

OFFICIAL

OFFICIAL

Planning Secretary's Environmental Assessment Requirements

Section 4.12(8) of the *Environmental Planning and Assessment Act 1979*

Part 8 of the *Environmental Planning and Assessment Regulation 2021*

Application Number	SSD-72430958
Project	<p>Finley BESS, which includes:</p> <ul style="list-style-type: none"> the construction, operation and decommissioning of a battery energy storage system (BESS) with an estimated capacity of approximately 100MW / 200 MWh; and ancillary infrastructure including transmission and connection works.
Location	Riverina Highway, Finley, within the Berrigan Shire LGA
Proponent	BESS Pacific Pty Ltd
Date of Issue	18 July 2024
General Requirements	<p>The Environmental Impact Statement (EIS) for the development must meet the minimum form and content requirements in Part 8 of the <i>Environmental Planning and Assessment Regulation 2021</i> (the Regulation) and must have regard to the <i>State Significant Development Guidelines</i>, and any relevant planning circulars.</p> <p>In particular, the EIS must include:</p> <ul style="list-style-type: none"> a stand-alone executive summary; a full description of the development, including: <ul style="list-style-type: none"> details of construction, operation and decommissioning, including any staging of the development; a high quality site plan at an adequate scale showing all infrastructure and facilities (including any infrastructure that would be required for the development, but the subject of a separate approvals process); the Project Area (as per Table 1 of the <i>SSD guidelines - preparing an environmental impact statement</i>) and Development Footprint (disturbance area including but not limited to areas for infrastructure, road works, access tracks, defendable space, fencing and temporary laydown); a high quality detailed constraints map identifying the key environmental and other land use constraints that have informed the final design of the development; and

	<ul style="list-style-type: none"> - confirmation if the project is designated development in accordance with the <i>Environmental Planning and Assessment Act 1979</i> (EP&A Act) and the Regulation; • consistency in information presented in the EIS and all technical reports, including distances, development footprint, project design and infrastructure proposed, construction timeframes and receiver numbers; • a table of commitments including mitigation measures; • a strategic justification of the development focusing on site selection and the suitability of the proposed site with respect to potential land use conflicts with existing and future surrounding land uses (including existing land use, other proposed or approved energy facilities, major projects, rural/residential development, Crown lands within and adjacent to the project site and subdivision potential); • a risk assessment of the potential impacts of the development, identifying the key issues for further assessment; • an assessment of the likely impacts of the development on the environment, and any other significant issues identified in the above risk assessment, focusing on the specific issues identified below, including: <ul style="list-style-type: none"> - a description of the existing environment likely to be affected by the development using sufficient baseline data; - an assessment of the likely impacts of all stages of the development (which is commensurate with the level of impact), including any cumulative impacts of the site and existing, approved or proposed developments in the region and impacts on the site and any road upgrades, taking into consideration any relevant legislation, environmental planning instruments, guidelines, policies, plans and industry codes of practice including the <i>Cumulative Impact Assessment Guideline</i> (DPIE, 2022); - a description and assessment if staging of the project is proposed, including any site mobilisation or pre-construction works - a description of the measures that would be implemented to avoid, mitigate and/or offset the impacts of the development (including draft management plans for specific issues as identified below); and - a description of the measures that would be implemented to monitor and report on the environmental performance of the development; • a consolidated summary of all the proposed environmental management and monitoring measures, identifying all the commitments in the EIS; • a detailed evaluation of the merits of the project as a whole, having regard to: <ul style="list-style-type: none"> - the requirements in Section 4.15 of the <i>Environmental Planning and Assessment Act 1979</i>, including the objects of the Act and how the principles of ecologically sustainable development have been incorporated in the design, construction and ongoing operations of the development; - the suitability of the site with respect to potential land use conflicts with existing and future surrounding land uses; - feasible alternatives to the development and its key components, including siting and project design alternatives to avoid areas of biodiversity value, opportunities for shared infrastructure with proposed developments in the region, and the consequences of not carrying out the development; and
--	---

	<ul style="list-style-type: none"> - a detailed consideration of the capability of the project to contribute to the security and reliability of the electricity system in the National Electricity Market, having regard to local system conditions and the Department's guidance on the matter. <p>Estimated Development Cost and Employment</p> <ul style="list-style-type: none"> • Provide the estimated development cost (EDC) of the development prepared in accordance with the relevant planning circular using the Standard Form of EDC Report; • Provide an estimate of the retained and new jobs that would be created during the construction and operational phases of the development, including details of the methodology to determine the figures provided; • The development application must also be accompanied by: <ul style="list-style-type: none"> - the consent of the owner/s of the land (as required in Section 23(1) of the EP&A Regulation); and - a declaration from a Registered Environmental Assessment Practitioner that the EIS includes the information specified in the <i>Department's Registered Environmental Assessment Practitioner Guidelines</i>.
Key issues	<p>The EIS must address the following specific matters:</p> <p>Biodiversity – including:</p> <ul style="list-style-type: none"> • an assessment of the biodiversity values, and the likely biodiversity impacts of the project, in accordance with Section 7.9 of the <i>Biodiversity Conservation Act 2016</i> (NSW) (BC Act), having regard to <i>the Biodiversity Assessment Method (BAM) 2020</i> and documented in a Biodiversity Development Assessment Report (BDAR), unless a BDAR Waiver is issued for the development. The BDAR must: <ul style="list-style-type: none"> - be prepared using the approved BDAR template; - document the application of the avoid, minimise and offset framework including assessing all direct, indirect and prescribed impacts in accordance with the BAM; - assess the impacts associated with all ancillary infrastructure, including the transport route road upgrades; - include an assessment for serious and irreversible impacts (SAIL) in accordance with Section 9.1 of the BAM; - include a strategy to offset any residual impacts of the development in accordance with the BC Act; and - be finalised by an accredited assessor as BAM-compliant within 14 days of submission. <p>unless BCS and DPHI determine the proposed development is not likely to have any significant impacts on biodiversity values;</p> • an assessment of the likely impacts on listed aquatic threatened species, populations or ecological communities, scheduled under the <i>Fisheries Management Act 1994</i>, and a description of the measures to minimise and rehabilitate impacts; • a cumulative impact assessment of biodiversity values in the region from nearby developments; and

	<ul style="list-style-type: none"> • if an offset is required, details of the measures proposed to address the offset obligations. <p>Heritage – including:</p> <ul style="list-style-type: none"> • An Aboriginal Cultural Heritage Assessment Report (ACHAR) prepared in accordance with the Guide to Investigating, Assessing and Reporting on Aboriginal Cultural Heritage in NSW (OEH, 2011) and the Code of Practice for the Archaeological Investigation of Aboriginal Objects in NSW (DECCW, 2010), identifying, describing, and assessing any impacts to any Aboriginal cultural heritage sites or values associated with the site (including impacts from any proposed earthworks, construction works, and road works), and including results of archaeological test excavations (where required), undertaken in accordance with the relevant standards and requirements; • evidence of adequate and ongoing consultation with Aboriginal communities in determining and assessing impacts, identifying and selecting options for avoidance of Aboriginal cultural heritage and identifying appropriate and mitigation measures (including the final proposed measures), having regard to the <i>Aboriginal Cultural Heritage Consultation Requirements for Proponents</i> (DECCW, 2010), including the consultation process within; and • assess the impact to historic heritage having regard to the <i>NSW Heritage Manual</i>. <p>Land – including:</p> <ul style="list-style-type: none"> • a detailed justification of the suitability of the site and that the site can accommodate the proposed development having regard to its potential environmental impacts, land contamination, permissibility, strategic context and existing site constraints; • an assessment of the potential impacts of the development on existing land uses on the site and adjacent land, including: <ul style="list-style-type: none"> - agricultural land, flood prone land, nearby drinking water catchments, Crown lands, mining, quarries, mineral or petroleum rights (if relevant); - a soil survey to determine the soil characteristics and consider the potential for salinity, acid sulfate soils, and erosion to occur; and - a cumulative impact assessment of nearby developments; • an assessment of the compatibility of the development, including any proposed accommodation camps with existing land uses, during construction, operation and after decommissioning, including: <ul style="list-style-type: none"> - consideration of the zoning provisions applying to the land, including subdivision in consultation with Council (if proposed); - completion of a Land Use Conflict Risk Assessment in accordance with the Department of Industries <i>Land Use Conflict Risk Assessment Guide</i>; and - an assessment of impact on agricultural resources and agricultural production on the site and region <p>Visual – including a detailed assessment of the likely visual impacts (including night lighting) of all components of the project (including transmission lines, substations and any other ancillary infrastructure) on surrounding residences (including approved developments, lodged development applications and</p>
--	---

dwelling entitlements) and key locations, scenic or significant vistas and road corridors in the public domain and provide details of measures to mitigate and/or manage potential impacts.

Noise – including an assessment of the construction noise impacts (including impacts from proposed road upgrades) of the development in accordance with *the Interim Construction Noise Guideline (ICNG)*, operational noise impacts in accordance with the *NSW Noise Policy for Industry (2017)*, cumulative noise impacts (considering other developments in the area), including (where appropriate):

- identification of impacts associated with construction, site emission and traffic generation at noise affected sensitive receivers, including the provision of operational noise contours;
- details of noise monitoring survey, background noise levels and amenity noise levels at the most-affected residential receivers;
- details of manufacturer specifications for plant and equipment and noise source inventory (demonstrating worst-case modelling of plant and equipment);
- an assessment of ‘worst case’ noise emission scenarios;
- consideration of annoying characteristics of noise and prevailing meteorological conditions in the study area; and
- details and analysis of the effectiveness of proposed management and mitigation measures to adequately manage identified impacts, including a clear identification of residual noise and vibration impacts following application of these mitigation measures and details of any proposed compliance monitoring programs.

Transport – including:

- an assessment of the peak and average traffic generation, including light vehicles, shuttle buses, heavy vehicles and high risk heavy vehicles requiring escort and construction worker transportation;
- an assessment of the likely transport impacts to the site access route(s), including the above listed vehicles, site access point(s), any Crown land, particularly in relation to the capacity and condition of the roads, road safety and intersection performance;
- a cumulative impact assessment of traffic from nearby developments (including mining operations); and
- provide details of measures to mitigate and / or manage potential impacts (developed in consultation with the relevant road authorities)
 - a schedule of all required road upgrades (including resulting from heavy vehicle and over mass / over dimensional traffic haulage routes),
 - clear figures of proposed road upgrades (including the site access point), and
 - road maintenance contributions, and any other traffic control measures.

Water – including:

	<ul style="list-style-type: none"> • an assessment of the likely impacts of the development (including flooding and flood modelling) on surrounding watercourses (including their Strahler Stream Order), groundwater resources and surface water movements, and measures proposed to monitor, reduce and mitigate these impacts including water management issues; • a site water balance for the development; • details of water requirements and supply arrangements for construction and operation (including consultation with suppliers); • a description of the erosion and sediment control measures that would be implemented to mitigate any impacts in accordance with <i>Managing Urban Stormwater: Soils & Construction</i> (Landcom, 2004) and <i>Managing Urban Stormwater: Soils and construction - Volume 2A manual</i> (Landcom, 2008); • assessing the impacts of the development, including any changes to flood risk and overland flows on-site or off-site, and detail design solutions and operational procedures to mitigate flood risk where required; and • where the project involves works within 40 metres of any river, lake or wetlands (collectively waterfront land), identify likely impacts to the waterfront land, and how the activities are to be designed and implemented in accordance with the <i>DPI Guidelines for Controlled Activities on Waterfront Land</i> (2018) and (if necessary) <i>Why Do Fish Need to Cross the Road? Fish Passage Requirements for Waterway Crossings</i> (DPI 2003), and <i>Policy & Guidelines for Fish Habitat Conservation & Management</i> (DPE, 2013); • identification of any flood risk on site having regard to adopted flood studies, the potential effects of climate change and any relevant provisions of the NSW Flood Risk Management Manual; <ul style="list-style-type: none"> - where the development could alter flood behaviour, affect flood risk to the existing community or expose its users to flood risk, provide a flood impact and risk assessment (FIRA) prepared in accordance with the Flood Impact and Risk Assessment – Flood Risk Management Guide LU01; - detailed design solutions and operational procedures to mitigate flood risk where required. <p>Hazards – including:</p> <ul style="list-style-type: none"> • <i>Dangerous Goods</i> - a preliminary risk screening completed in accordance with the State Environmental Planning Policy (<i>Resilience and Hazards</i>); • <i>Battery Energy Storage System</i> - a Preliminary Hazard Analysis (PHA) prepared in accordance with <i>Hazardous Industry Planning Advisory Paper No. 6 – Guideline for Hazard Analysis</i> (DoP, 2011) and <i>Multi-Level Risk Assessment</i> (DoP, 2011). The PHA must consider all recent standards and codes and verify separation distances to on-site and off-site receptors to prevent fire propagation and compliance with the Department’s <i>Hazardous Industry Advisory Paper No. 4, ‘Risk Criteria for Land Use Safety Planning</i> (DoP, 2011). The PHA must consider the effect of bushfires on batteries or other components of the BESS;
--	---

	<ul style="list-style-type: none"> • <i>Health</i> – an assessment of potential hazards and risks including but not limited to fires, spontaneous ignition, electromagnetic fields or the proposed grid connection infrastructure against <i>the International Commission on Non-Ionizing Radiation Protection (ICNIRP) Guidelines for limiting exposure to Time-varying Electric, Magnetic and Electromagnetic Fields</i>; and • <i>Bushfire</i> - identify potential hazards and risks associated with bushfires / use of bushfire prone land including the risks that a BESS would cause a bush fire and demonstrate compliance with the <i>RFS Planning for Bush Fire Protection 2019</i>. <p>Social – including an assessment of the social impacts or benefits of the project for the region and the State as a whole in accordance with the <i>Social Impact Assessment Guideline</i> (DPE, 2023), including consideration of any increase in demand for community infrastructure services, and consideration of construction workforce accommodation.</p> <p>Economic – including an assessment of the economic impacts or benefits of the project for the region and the State as a whole and provide details of any proposed voluntary benefit sharing programs.</p> <p>Waste – including</p> <ul style="list-style-type: none"> • identify, quantify and classify the likely waste stream to be generated during construction, operation, and decommissioning, and describe the measures to be implemented to manage, reuse, recycle and safely dispose of this waste (in consultation with waste facilities, including Council); and • provide a waste management plan (as appropriate)..
Plans and Documents	<p>The EIS must include all relevant plans, diagrams and relevant documentation required under Part 3 of the EP&A Regulation. Provide these as part of the EIS rather than as separate documents.</p> <p>In addition, the EIS must include high quality files of maps and figures of the subject site and proposal.</p>
Legislation, Policies & Guidelines	<p>The assessment of the key issues listed above must take into account relevant guidelines, policies, and plans as identified.</p> <p>A list of some of the legislation, policies and guidelines that may be relevant to the assessment of the project can be found at:</p> <ul style="list-style-type: none"> • https://www.planning.nsw.gov.au/Policy-and-Legislation/Planning-reforms/Rapid-Assessment-Framework/Improving-assessment-guidance; • https://www.planningportal.nsw.gov.au/major-projects/assessment/policies-and-guidelines; and • http://www.environment.gov.au/epbc/publications#assessments.
Consultation	<p>During the preparation of the EIS, you should consult with the relevant local, State or Commonwealth Government authorities, infrastructure and service providers, community groups, affected landowners and any exploration licence and/or mineral title holders.</p> <p>In particular, you must undertake detailed consultation with affected landowners surrounding the development, relevant government agencies, including the relevant local Council.</p>

	<p>The EIS must:</p> <ul style="list-style-type: none">• detail how engagement undertaken was consistent with the <i>Undertaking Engagement Guidelines for State Significant Projects</i> (DPIE, 2024); and• describe the consultation process and the issues raised, and identify where the design of the development has been amended in response to these issues. Where amendments have not been made to address an issue, an explanation should be provided.
Expiry Date	<p>If you do not lodge a Development Application and EIS for the development within 2 years of the issue date of these SEARs, your SEARs will expire. If an extension to these SEARs will be required, please consult with the Planning Secretary 3 months prior to the expiry date.</p>

4 July 2025

TfNSW reference: REN25/00086/002

Your reference: SSD-72430958

Department of Planning, Housing and Infrastructure
Locked Bag 5022
PARRAMATTA NSW 2124

Attention: Samantha Wynn

**SSD-72430958, Finley Battery Energy Storage System - Various Lots, Berrigan Shire Council;
Response to Environmental Impact Statement**

Dear Samantha,

Transport for NSW (TfNSW) is responding to the exhibition of the Finley Battery Energy Storage System (BESS), which was exhibited from 29 May 2025 to 27 June 2025 and was referred via the Major Projects Portal.

TfNSW has reviewed the Environmental Impact Statement (EIS) prepared by Premise dated 7 May 2025 and the Traffic Impact Assessment (TIA) prepared by Premise dated 2 May 2025, as key documents for preparing this response.

The information provided in the EIS does not demonstrate that the Finley BESS has mitigated the traffic safety, efficiency and risks to TfNSW assets on the State road network. TfNSW therefore requests additional information relating to the key issues identified in **Attachment A** to form part of a revised TIA and EIS (where applicable), to be submitted with the Response to Submissions (RtS).

On request, TfNSW can meet with DPHI and the Applicant to discuss the information in **Attachment A and B**. If you have any questions, please contact Glen Hanchard, Development Services Case Officer, at 1300 019 680 or email development.renewables@transport.nsw.gov.au

Yours sincerely,



Nathan Boscaro
Manager Development Services - West
Transport Planning
Planning, Integration and Passenger

OFFICIAL

**SSD-72430958, Finley Battery Energy Storage System - Various Lots, Berrigan Shire Council;
Response to Environmental Impact Statement**

This attachment relates to TfNSW's response dated 4 July 2025 reference REN25/00086/002.

TfNSW additional information requested | TfNSW comments

TfNSW requests the additional information on the key issues identified, as detailed below, to be included in a revised TIA and EIS (where applicable) and submitted with the Response to Submissions (RtS). It must be clear where changes have been made in the revised TIA, which can be in the form of a document with tracked changes or a table provided in the updated TIA detailing the changes made, including where and what they are.

Refer to the advisory notes below for information to assist with revising the TIA.

Key Issue 1 - Traffic Impact Clarifications

The worst-case scenario of both the AM and PM peaks of the development has not been adequately addressed. The project's impact on the state road network due to increased traffic volumes must be adequately considered. The proponent is to ensure discrepancies are corrected and to consider the worst-case scenario for both AM and PM peaks, including background traffic and turning volumes. TfNSW requires the following matters to be addressed in the response to submissions

- a) The following issues are required to be addressed relating to the traffic assessment and subsequent turn warrants provided:
 - i. Section 4.3.1 of the TIA notes that the turn warrants assessment focuses on the AM peak. The reason given is that the AM peak is likely to generate the highest number of trips, which determines the intersection treatments. The turn warrant assessment is to be revised to include the PM peak hour traffic volumes for project traffic at peak of construction. The turn warrant assessments are to be prepared in accordance with section 3.25 of Part 6 of the *Austroads Guide to Traffic Management* (see advisory note 6).
 - ii. The AM and PM peaks identified in the SIDRA analysis differ from those used in the turn warrant assessment. The SIDRA analysis on page 4.3.4.1 indicates that the worst-case scenario using the Wednesday background traffic data was used, whilst in Section 3.6.1.2, an average was used across all days. It is essential to understand the AM and PM peaks, as they inform the worst-case scenario applied to the turn warrants. The TIA is to be revised to ensure that the SIDRA analysis and turn warrants assessment represent the same worst-case scenario for the AM and PM peak hours at the peak of construction.

OFFICIAL

Key issue 2: Issues with utilising existing turn treatments

The existing turn treatments are deficient. The proponent is to provide strategic concept designs demonstrating compliance with Austroads Guide to Road Design Part 4A. The project intersection strategic designs must be updated based on the outcome of the updated analysis and to ensure that the largest vehicles using the intersection can be accommodated within the pavement. TfNSW requires the following matters to be addressed in the response to submissions.

a) Issue with using the existing Auxiliary Left Turn treatment (AUL)- Canalla Road/Riverina Highway

The proposal intends to rely on the existing treatments at the intersection of Canalla Road/Riverina Highway. Review of the AUL(s) on Riverina Highway to facilitate a left turn does not comply with Austroads. It will not be able to cater for the increased traffic and design vehicles based on the existing deficiencies, as the AUL(s) does not comply with the length and width requirements for an AUL(s) and do not include sufficient arrow line markings. Strategic concept designs will be required for the upgrade of the deficient AUL(s) that demonstrate the scope of the upgrades needed for the AUL(s) to achieve compliance with Austroads. Refer to advisory notes for specific references to Austroads concerning this point.

b) Issue with the existing Basic Right Turn treatment (BAR)- Canalla Road/Riverina Highway

The Basic Right Turn treatment on Riverina Highway, which facilitates the right turn into Canalla Road, does not comply with Austroads. The increased traffic and proposed design vehicles will exacerbate the current safety issues with the non-compliant BAR. Strategic concept designs will be required to be submitted that demonstrate the scope of the upgrades necessary to the existing BAR to achieve compliance with Austroads and TfNSW requirements. The strategic concept designs will need to address the following specific non-compliances with the existing BAR:

- i. BAR does not meet the minimum requirement for the situation whereby a road user is not allowed to enter a dedicated left turn lane to pass / navigate around a stored vehicle turning right into the side road.

The proponent must design a compliant BAR intersection treatment and line mark the edge line at a constant 3.5m from the centerline to provide a widened shoulder to satisfy the requirement of a BAR. (AGR Part 4A – Section 7) The re-design will impact the existing treatments to Marantellis/Riverina Highway. The proponent in their re-design will therefore, need to consider what an appropriate BAR treatment is for both the Canalla and Marantellis Road intersections with the Riverina Highway and ensure both roads have compliant treatments. Consideration to upgrading the intersection with opposing CHRs should be given by the proponent due to the unconventional existing intersection design.

- ii. A hold line is to be included set back from the through edge line to hold side road traffic free of the widened shoulder to ensure the BAR intersection treatment will operate as intended. Austroads Figure 7.1 demonstrates requirements for a compliant hold line setback. The setback should take into consideration the unconventional design of the road.

OFFICIAL

c) Road Train width requirement

The Riverina Highway is a gazetted Road Train route (i.e B-triples) at this location.. The strategic concept designs are to demonstrate an increase of the width of the AUL(S) and BAR for the Canalla Road/Riverina Highway intersection to accommodate the road train heavy vehicles passing the turning project traffic. See advisory note for references to Austroads.

d) Swept Paths

Swept paths are required to be provided for the largest heavy vehicle and high-risk OSOM configuration (corresponding to the design and check vehicle) required to use each intersection, access point or navigate pinch points along the high-risk OSOM routes. This must be prepared following Austroads Design Vehicles and Turning Path Templates.

e) Consideration of bus bays

The proponent is to demonstrate a safe and conforming solution for the intersection upgrades that take into consideration the existing bus bays. The proponent is to be aware, that if modifications to the bus bays are required to achieve an optimal design, consultation will need to occur. Consideration of relocating the bus bays to allow for an improved, optimized design, should be given. There is potential for a rear end type crash when the bus bay is in use, as there appears to be insufficient offset between the intersection treatment and the bay. Line marking the edge line through at a constant offset should also be considered.

f) Broockmanns Road consideration

The proposal also intends to use Broockmanns Road for a proportion of vehicle traffic. The route vehicles will take to access Broockmanns Road is to be identified and further traffic assessments and turn warrants are required for the Will Hamilton St/Riverina Highway intersection, if these intersections are proposed to be used by project traffic.

Key Issue 3 - Staging and pre-construction minor works

Staging/timing of pre-construction minor works/enabling works requires clarification. The updated TIA needs to quantify the traffic volumes, timeframes, and routes (same or different from construction), as well as mitigation measures (e.g., TTM, current traffic conditions) and flow-on impacts for all stages. TfNSW requires the following matters to be addressed in the response to submissions

- a) As required by the Secretary's Environmental Assessment Requirements (SEARs) response, the proponent is to provide a separate analysis of pre-construction minor works to the construction analysis. This should include the list of requirements provided by the SEARs, including:
 - i. Identification of the traffic volumes and traffic types, inclusive of the largest design vehicle, including those specifically in the AM/PM peak hours. Swept path analysis is required for the existing intersection if concurrent turning movements for the design heavy vehicle are intended at this intersection during the pre-construction minor works phase.
 - ii. Identification of any measures proposed to reduce the project traffic and impacts during this period, i.e carpooling, shuttle buses, staggering of traffic and inclusion of enforceable mitigation measures that can be monitored for compliance.
 - iii. Provide a schedule of the proposed pre-construction minor works and program of works.

OFFICIAL

Identifying the hours for pre-construction minor works.

- iv. Assess any overlap of construction and pre-construction minor works periods must be included in the traffic assessment for this stage, before completion of the intersection upgrade.

Key Issue 4 – The high-risk OSOM route assessment scope and mitigation measures

The high-risk oversized overmass (OSOM) vehicle route assessment does not fully consider impacts to the state road network across all identified routes. Further detail regarding these impacts is requested to ensure the compliance of the road upgrades and mitigation measures in accordance with the Austroads Guide to Road Design, the Austroads Guide to Temporary Traffic Management, and TfNSW requirements. TfNSW requires the following matters to be addressed in the response to submissions

- a) This section provides overall considerations for the route from the Port of Melbourne which will need to be resolved within the revised TIA.
 - i. NHVR Route ID has not been provided. This is required to ensure a complete assessment of route considerations has been provided. See advisory note 4.
 - ii. The route assessment identifies heavy-massed and large-axle group load vehicles. Bridge and culvert assessments are required for TfNSW assets to assess their suitability for use of these vehicle types. The proponent is to contact TfNSW Special Permits Unit (see advisory note 7). The route assessment is to be revised based on the outcomes of the TfNSW bridge and culvert assessments.
 - iii. The route study provided by ARES noted that the exact weights and dimensions of the Transformer are yet to be finalised, with guide dimensions offered. The maximum dimensions are to be provided in the updated route study.
 - iv. Pinch point 17 demonstrates that to make the turn into Canalla Road from the Riverina Highway, the high-risk OSOM will be entering into the opposing lanes. This will require traffic to be stopped; however, sufficient detail on how this will occur is not provided. The updated information will need to clarify how long traffic will be stopped (TfNSW notes traffic cannot be stopped for more than 10 minutes). Please include this detail in the updated TIA and ensure any other locations where traffic is required to be stopped are provided.
 - v. The route study demonstrates that medians will be tracked over, including at the intersection of the Newell Highway and Riverina Highway. See figure 1 within **Attachment B**. The proponent is to investigate whether the high-risk OSOM can avoid tracking over any medians or other infrastructure on the state road network.
 - vi. Strategic concept designs will be required for works required along the state road network (for example, the median identified in e) that identify the scope of the works that would be necessary to ensure the asset could be made suitable for traversing (i.e pavement strengthening) or temporary removal.
 - vii. Temporary changes to state road assets will need to include the length of time they will be affected, any interim treatments (e.g., line marking), and when and what will replace the asset post-completion of high-risk OSOM movement.

OFFICIAL

- viii. Signs are proposed to be removed at the Riverina Highway / Newell Highway. Details on any temporary signage and the timeframe for replacing traffic signs are to be included.
- ix. An extensive review of the high-risk OSOM routes regarding vertical and horizontal obstructions alignment, including existing formations, crossings, bridges, culverts, intersection roadside furniture, hazards, roundabouts, traffic signals, level crossings, existing developments, signage and powerlines.
- x. The route assessment does not include relevant TfNSW projects or other third-party projects that are currently under construction, or will be completed, on the State road network for the route. The route assessment must be updated to include mitigation measures or modifications required to navigate any identified road or rail projects along the routes (ie, Council works for Finley Main St project expected to commence in the financial year 25/26, see figure in Attachment B for location of works).
- xi. The pull-over bays and rest areas have been identified with swept paths; however, the diagrams provided aren't fully dimensioned as required. See advisory note 1 and 5.
- xii. Rail requirements are to be considered. See advisory note 9 and 10.

TfNSW Advisory Notes

1. Strategic concept designs are required for works along the state road network route.
[Strategic-Design-requirements-for-DA-Factsheet.pdf](#)
2. Auxiliary Left Turn treatment must comply with Austroads Guide to Road Design Part 4A, Figure 8.3. See here: <https://austroads.gov.au/publications/road-design/agrd04a>
3. Basic Right Turn treatment must meet the requirements of Austroads Guide to Road Design Part 4A. Ensure the C value is compliant for road trains as part of figure 7.1.
4. The updated route study must include a reference to a Route ID utilising the NHVR portal website.
[Route Planner Tool](#).
5. The rest areas and pull over locations are required to be sufficient to comply with NHVR fatigue management requirements and any day or night time travel restrictions on the network.
6. Warrant assessments are to be in accordance with Section 3.25 of Part 6 of the Austroads Guide to Traffic Management.
7. Bridge assessments for TfNSW assets can be obtained by contacting spu@transport.nsw.gov.au.
8. All pavement that is to accommodate the project traffic, heavy vehicles, light vehicles, and high-risk OSOM, is to consist of permanent pavement treatments that are consistent with the existing state road pavement.
9. It is noted that the Newell Highway section on the proposed OSOM Route crosses the non-operational CRN rail Corridor from Narrandera to Tocumwal at Tocumwal. If any adverse impacts to CRN corridors are identified, the applicant shall seek approvals from UGLRL and TfNSW. Please note that the applicant must adhere to the transport management and safety requirements of UGLRL and TfNSW for matters involving the CRN rail corridor.
10. If the proponent requires the use of UGLRL assets, the applicant must consult with UGLRL. This can be done through lodgment of a request for a permit via the National Heavy Vehicle portal, or directly to UGLRL via "heavyvehicle@uglregionallinx.com.au". The applicant must submit the request at least two (2) months before passage and include the specifications of their OSOM and heavy vehicles (axial loading and axial spacing as well as dimensions of the heavy vehicles) with the lodgment of the request.

OFFICIAL

Attachment B



Figure 1 – Affected median, intersection of the Newell and Riverina Highways.

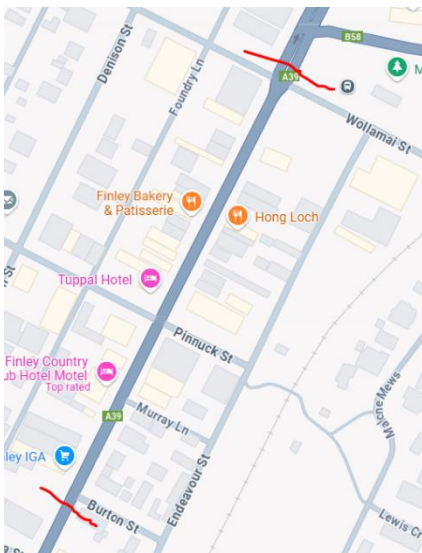

Figure 2 – Finley Main Street project works will be located on the Newell Highway between Wollamai St and Burton St. Works will include Pavement works around the parking areas, pedestrian crossing relocation and stormwater drainage works. An indication of the location is provided above, however consultation will need to occur with Council for the full extent of works.

OFFICIAL

APPENDIX E

DRAFT TRAFFIC MANAGEMENT PLAN (TMP)



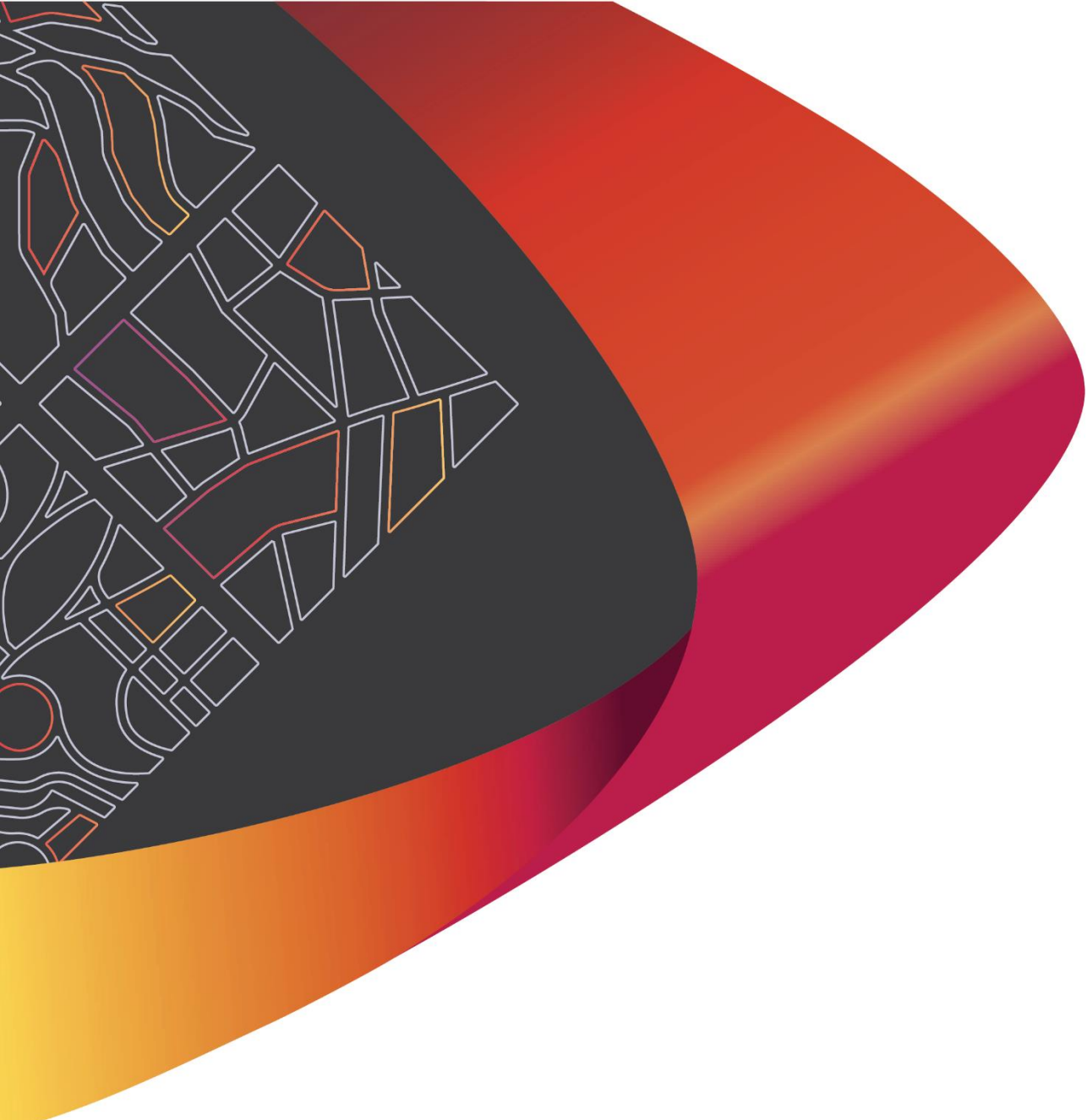

DRAFT TMP
Finley Battery Energy Storage System

BESS Pacific Pty Ltd

P001993 TMP R01

Rev: Draft B

23 January 2026



Premise

© Premise 2026

This report has been prepared by Premise Australia for BESS Pacific C/- Gransolar Development Australia Pty Ltd; may only be used and relied on by Gransolar Development Australia Pty Ltd; must not be copied to, used by, or relied on by any persons other than Gransolar Development Australia Pty Ltd without the prior written consent of Premise. If Gransolar Development Australia Pty Ltd wishes to provide this Report to a third party recipient to use and rely upon, the recipient agrees: to acknowledge that the basis on which this Report may be relied upon is consistent with the principles in this section of the Report; and to the maximum extent permitted by law, Premise shall not have, and the recipient forever releases Premise from, any liability to recipient for loss or damage howsoever in connection with, arising from or in the respect of this Report whether such liability arises in contract, tort including negligence.

Document Reference: P001993 Draft TMP R01 REV B

Document Authorisation				
Revision	Revision Date	Proposal Details		
Draft A	2/04/2025	Draft – Client Review		
Draft A	11/04/2025	Amended as per client comments		
Draft B	23/01/2026	Final draft		
Prepared by		Reviewed by		Authorised by
Marina Kleyweg		Daniel Belkin		[Name]



CONTENTS

1. INTRODUCTION	1
1.1 BACKGROUND.....	1
1.2 PROJECT OVERVIEW.....	1
1.3 OBJECTIVES OF DRAFT TMP.....	2
1.4 STATUTORY REQUIREMENTS.....	2
1.5 EIS-COMMITTED ACTIONS.....	2
1.6 DOCUMENTS AND GUIDELINES REFERENCED IN THE TMP.....	3
1.7 ROAD AUTHORITY CONSULTATION.....	3
2. EXISTING ROAD ENVIRONMENT	5
2.1 SITE LOCATION.....	5
2.2 ROAD NETWORK.....	7
2.2.1 KEY ROADS AND INTERSECTIONS.....	7
2.2.2 TRAFFIC AND ROAD ENVIRONMENT.....	7
2.2.3 HEAVY VEHICLE ACCESS ROUTES.....	7
2.2.4 TRAFFIC VOLUMES.....	8
2.3 PUBLIC TRANSPORT SERVICES.....	9
2.4 PEDESTRIAN AND CYCLING ROUTES.....	10
2.5 DEVELOPMENT SITE ACCESS.....	10
2.6 CRASH HISTORY.....	10
3. CONSTRUCTION OVERVIEW	11
3.1 PROJECT DESCRIPTION.....	11
3.2 DURATION OF CONSTRUCTION WORKS AND SCHEDULE.....	11
3.3 CONSTRUCTION TIMES.....	12
3.4 WORKFORCE TRANSPORT.....	12
3.4.1 WORKFORCE ACCOMMODATION.....	12
3.4.2 WORKFORCE IN OPERATION (PHASE 2).....	12
3.5 ON SITE PARKING.....	12
3.6 CONSTRUCTION VEHICLES AND EQUIPMENT.....	13
3.7 TRAFFIC MOVEMENTS – PHASE 1 (CONSTRUCTION).....	13
3.8 PROPOSED MITIGATION MEASURES.....	14
3.9 OPERATIONAL TRAFFIC IMPACT.....	14
3.10 DECOMMISSIONING TRAFFIC IMPACTS.....	15
4. OSOM VEHICLE MOVEMENTS	16
4.1 DESIGN VEHICLE.....	16
4.2 PROPOSED OSOM ROUTE.....	16
4.3 RAILWAY CROSSINGS.....	18
4.4 BRIDGES AND CULVERTS.....	18
5. TRAFFIC MANAGEMENT STRATEGY	20
5.1 DRIVER PROTOCOLS.....	20



5.2	DELIVERY LOGISTICS	20
5.3	INFORMATION AND COMMUNICATIONS	20
5.4	ON-SITE MITIGATION MEASURES	21
5.4.1	STAFF PARKING.....	21
5.4.2	DELIVERIES AND MATERIALS HANDLING	21
5.4.3	TRUCK CONVOYS.....	21
5.4.4	EMERGENCY VEHICLE ACCESS	21
5.4.5	ON-SITE TRAFFIC MANAGEMENT	22
5.5	OVERSIZE/OVERMASS OPERATING PROTOCOLS	22
5.6	PUBLIC TRANSPORT	22
5.7	ORGANISED WORKFORCE TRANSPORT PICK-UP / DROP-OFF LOCATIONS.....	23
5.8	SPECIAL EVENTS AND OTHER WORKS	23
5.8.1	EVENTS	23
5.8.2	OTHER WORKS AND PROJECTS.....	23
5.9	HAZARDOUS GOODS AND DANGEROUS MATERIALS	24
5.9.1	TRANSPORTING DANGEROUS GOODS	24
5.10	RESPONDING TO LOCAL CLIMATE CONDITIONS	25
5.10.1	FLOODING.....	26
5.10.2	BUSHFIRE.....	26
5.10.3	DIRT AND DUST.....	28
5.11	EMERGENCIES	28
6.	ROAD MAINTENANCE	29
7.	TRAFFIC MANAGEMENT RESPONSIBILITIES.....	30
7.1	LEAD PROJECT MANAGER.....	30
7.2	LEAD CONSTRUCTION MANAGER	30
7.3	WORKERS AND SUBCONTRACTORS	30
8.	IMPLEMENTING TMP	31
8.1	HAZARD IDENTIFICATION, RISK ASSESSMENT AND CONTROL	31
8.2	TRAFFIC GUIDANCE SCHEMES AND ROAD OCCUPANCIES	33
8.2.1	ROAD OCCUPANCY LICENCES (ROLS)	33
8.2.2	GENERAL DESCRIPTION OF CONSTRUCTION SIGNAGE TO BE USED.....	33
8.2.3	TRAFFIC GUIDANCE SCHEMES FOR VARIOUS STAGES OF CONSTRUCTION WORKS.....	33
9.	COMMUNICATING TMP REQUIREMENTS	34
9.1	SITE INDUCTION	34
9.2	SITE SPECIFIC TRAFFIC GUIDANCE SCHEME	34
9.3	TOOLBOX TALKS.....	34
9.4	SAFE WORK METHOD STATEMENTS (SWMS)	34
10.	MONITORING AND MEASUREMENT	35
10.1	TMM INSPECTIONS, TMP REVIEW, AUDITS AND RECORD KEEPING	35
10.1.1	REVIEW REQUIREMENTS	35
10.1.2	RECORD KEEPING REQUIREMENTS	36



10.2 INCIDENTS AND NON-COMPLIANCES.....	36
10.2.1 DEFINITIONS.....	36
10.2.2 CORRECTIVE ACTIONS.....	37
10.2.3 NON-COMPLIANCE RESPONSE PROTOCOL.....	37
10.2.4 INCIDENT RESPONSE PROTOCOL.....	37
10.3 COMPLAINTS MANAGEMENT.....	38
10.3.1 MEANS OF MAKING A COMPLAINT.....	38
10.3.2 COMPLAINTS REGISTER.....	38
10.3.3 COMPLAINT MANAGEMENT.....	38
10.3.4 DISPUTE RESOLUTION.....	39
10.4 MANAGEMENT AND MONITORING SUMMARY.....	39
11. MANAGEMENT AND REPORTING.....	41
11.1 TMP REVIEW AND IMPROVEMENT.....	41
11.2 VARIATIONS TO STANDARDS AND PLANS.....	41
11.3 UPDATE OF STRATEGIES, PLANS OR PROGRAMS.....	42
11.4 NOTIFICATION OF DEPARTMENT.....	42
1. APPENDIX A - DRIVER CODE OF CONDUCT.....	44
1.1 INTRODUCTION.....	44
1.1.1 GENERAL.....	44
1.2 DRIVING PRACTICES.....	44
1.2.1 SAFE DRIVING PRACTICES.....	44
1.2.2 ESSENTIAL DRIVER CODE.....	45
1.2.3 DEFENSIVE DRIVING.....	46
1.2.4 HIGHWAY COURTESY.....	46
1.2.5 FINLEY BESS WORKS SPEED RESTRICTIONS.....	46
1.2.6 FATIGUE MANAGEMENT.....	46
1.2.7 APPROVED ROUTES.....	47
1.2.8 PARKING.....	48
1.2.9 REVERSING.....	48
1.2.10 RAW MATERIALS AND EQUIPMENT HAULAGE.....	48
1.2.11 ON ROUTE EMERGENCY PROTOCOLS.....	49
1.3 OTHER.....	49
1.3.1 ROAD TRAFFIC ACT AND ROAD RULES.....	49
1.3.2 CHAIN OF RESPONSIBILITY.....	49
1.3.3 DRIVING LICENCE.....	50
1.3.4 VEHICLE MINIMUM MAINTENANCE AND OPERATING CONDITION.....	50
1.3.5 ENVIRONMENT.....	50
1.3.6 NOISE CONTROL.....	50
1.4 TIMES OF OPERATION.....	51
1.5 COMPLAINTS, RESOLUTIONS AND DISCIPLINARY ACTION.....	51
1.5.1 PENALTIES AND DISCIPLINARY ACTION.....	51



APPENDICES

Appendix A DRIVER CODE OF CONDUCT43

TABLES

Table 1 - Relevant Conditions of Development Consent2

Table 2 - Traffic and Access mitigation measures – EIS commitments..... 3

Table 3 - Summary of TfNSW preliminary comments3

Table 4 – Key Roads7

Table 5 – Key Intersections Surrounding the Site.....7

Table 6 – 2011 AADT..... 9

Table 7 – Existing 2025 Peak Hour Traffic.....9

Table 8 – Estimated heavy vehicle movements13

Table 9 – Estimates of Average Daily Vehicle Trip Generation at Peak Construction activity.14

Table 10 – Peak Hour Traffic Generation for Proposed BESS during construction14

Table 11 - Proposed truck stops for fatigue management (source: OSOM Route Survey, Ares Group, January 2026)..... 18

Table 12 - Location of railway crossings (source: OSOM Route Survey, Ares Group, January 2026)18

Table 13 - Dangerous Goods to be stored on site.....24

Table 14 - Potential hazard categories to be considered (source: TfNSW Manual)31

Table 15 - Mandatory TTM monitoring activities35

Table 16 - Site Inspection and Monitoring Frequency Matrix.....39

Table 17 - Managing Departures in accordance with TS 05492 - Traffic control at work sites41



FIGURES

Figure 1 - Locality and surrounding road network	6
Figure 2 - B Double (25/26m) network in vicinity of the development site (source: NHVR)	8
Figure 3 - Road Crash History in vicinity of the subject site (2019-2023).....	10
Figure 4 - The largest vehicle anticipated to access the site (source: OSOM Route Study, Ares Group, Jan 2026)	16
Figure 5 - Proposed OSOM route for transformer transportation (source: OSOM Route Survey, Ares Group, January 2026)	17
Figure 6 - General OSOM route overview with key assets (source: NHVR route planner)	19
Figure 7 - TfNSW recommended risk evaluation matrix (source: TfNSW Manual)	32
Figure 8 - Hazard control framework	32

DRAFT



1. INTRODUCTION

Premise Australia Pty Ltd (Premise) have been commissioned by the BESS Pacific c/o Gransolar Development Australia to prepare a Draft Traffic Management Plan (TMP) to support State Significant Development Application (SSD-72430958) for the proposed Finley Battery Energy Storage System (BESS) and ancillary infrastructure including transmission and connection works at Lot 3 DP 740920 Riverina Highway (HW20), Finley NSW 2713, referred to as "development site" from here on. The proposed development is known as Finley BESS and is located within the Berrigan Shire Council (BSC) Local Government Area (LGA).

1.1 Background

The proposed BESS is located on a portion of Lot 3 DP740920 at Riverina Highway, Finley New South Wales (NSW) 2713 (BESS Site).

The proposed BESS site is agricultural in nature and free of supporting structures.

Access to the development site is from Riverina Highway via Canalla Road for heavy vehicles, and via Broockmanns Road for Transgrid vehicles and light vehicles.

The Project will involve the development, construction, operation, and eventual decommissioning of a BESS with a capacity of 100 MW_{AC}, 200 MWh connecting via above and below ground TL directly to the existing Transgrid Finley 132/66 kV substation.

Project life is 10 months (5.5 days per week – Monday to Friday regular hours and half day on Saturday).

1.2 Project Overview

The Finley BESS project comprises a BESS with a delivery capacity of approximately 100 MW/200 MWh, incorporating on-site energy storage containers, approximately 80 x 20-foot modular containers comprising of Lithium-Ion batteries with the appropriate cooling / protection system. Other physical features include a control room/switchgear and auxiliary transmission lines, car parking, landscaping, security fencing/lighting, and a single storage structure.

The BESS will connect to the Transgrid Finley substation located adjacent to the development site (southwest) via underground and/or overhead transmission lines, approximately 480 metres in length.

The development site will have an area of approximately 3.5 ha and will consist of all physical disturbance aspects associated with the development of the project.

The Finley BESS will comprise of the following key components:

- > Site establishment works including clearing of grassed area within the BESS boundary and minimal clearing for underground transmission line (TL), bulk earthworks and temporary construction compound;
- > Construction of hardstand, control room and switch gear, auxiliary transformer, battery enclosures, and inverter and transformer stations;
- > Development site road works to formalise internal access road to accommodate heavy vehicles movements including two accesses to Broockmanns Road;
- > Installation of approximately 80 x 20-foot modular containers comprising of Lithium-Ion batteries with the appropriate cooling and protection system and approximately 40 inverters (one per every two batteries) located externally to the modular containers;

- > Construction of 132 kV TL route ~480m length (underground TL) to facilitate connection to the existing Transgrid Finley 132/66 kV Substation and associated high voltage steel poles;
- > Construction of ancillary works including parking areas, water tanks, storage structures, stormwater management infrastructure, CCTV, security lighting and fencing; and
- > Vegetation buffer.

The primary components associated with the installation of the BESS are as follows:

- > Site investigations, vegetation clearing, levelling, access way construction, drainage system installation and installation of foundations/supports to install equipment on.
- > Transportation to site and installation of equipment.
- > Testing and commissioning of the equipment.
- > Operation and maintenance.

1.3 Objectives of Draft TMP

The TMP aims to:

Set out a document that will in its final form satisfy relevant conditions of the development consent;

Answer to pre-SEARs TfNSW comments;

Demonstrate how construction traffic is to be managed effectively and safely;

Demonstrate how environmental impacts of construction traffic can be managed and mitigated;

Outlines basic principles of traffic-related operational policies that are to be adhered to during the construction period.

1.4 Statutory Requirements

This TMP is prepared specifically to address the condition **XX** of the development consent; however, it will also reference the conditions **XX**. The table below outlines abovementioned conditions:

Table 1 - Relevant Conditions of Development Consent

DCC	Condition Requirements	Reference

1.5 EIS-Committed Actions

The table below outlines mitigations measures proposed in EIS and provides comments or appropriate reference in the TMP document addressing these commitments.



Table 2 - Traffic and Access mitigation measures – EIS commitments

Component	Action	Comment / Reference in TMP

1.6 Documents and Guidelines Referenced in the TMP

This TMP references the key documents submitted with SSD 72430958, as well as relevant guidelines. These documents include:

- > Finley BESS Environmental Impact Statement Rev C, 2025, prepared by Premise Australia (EIS);
- > Finley BESS Traffic Impact Assessment Rev D, 2026, prepared by Premise (TIA);
- > Finley BESS Land Use Conflict Risk Assessment, Rev A, 2025, prepared by Premise (LUCRA);
- > Finley BESS Preliminary Hazard Analysis, Rev 0, 2025, Riskon Engineering (Hazard Analysis);
- > Finley BESS OSOM Route Survey, Ares Group, R2, 2026 (OSOM Report)
- > Australian Standard 2890.1: Parking Facilities - Off-Street Car Parking (AS 2890.1);
- > Australian Standard 2890.2: Parking Facilities - Off-Street Commercial Vehicle Facilities (AS 2890.2);
- > Austroads Guide to Road Design Part 3: Geometric Design (GRD Part 3).
- > Austroads Guide to Road Design Part 4: Intersections and Crossings General (GRD Part 4);
- > Austroads Guide to Road Design Part 4A: Unsignalised and Signalised Intersections (GRD Part 4A);
- > Australian Standard 1742 Manual of Uniform Traffic Control Devices Part 3: Traffic Control for Works on Roads (AS 1742.3);
- > TfNSW Traffic Control at Work Sites Manual 2022 (TCW Manual);
- > Australian Dangerous Goods Code, 2024, Edition 7.9 (DGC).

1.7 Road Authority Consultation

This Draft Traffic Management Plan (TMP) has been prepared in accordance with the preliminary consultation advice provided by Transport for NSW (TfNSW) on 18th of January 2024 as part of the Pre-SEARs (Secretary’s Environmental Assessment Requirements) process.

Table 3 - Summary of TfNSW preliminary comments

Point	Section Addressed
A map of the primary transport route/s highlighting critical locations.	Section 4.2
Identification of local bus operations, including maps of routes/bus stops, and consultation with local bus operators.	Section 5.6



Point	Section Addressed
Safety initiatives for haulage through residential areas and/or school zones.	Section 5.3 and Appendix A
An induction process for vehicle operators and regular toolbox meetings.	Section 5.5 and 9.2
Consideration of the local climate conditions that may affect road safety during the life of the project (e.g. fog, wet and dry weather, icy road conditions).	Section 5.10
A public complaint resolution and disciplinary procedure.	Section 10.3
A complaint resolution and disciplinary procedure.	Section 10.3
Any proposed temporary measures such a Traffic Guidance Scheme (TGS)	Section 8.2
Community consultation measures for peak haulage periods	Section 7

DRAFT



2. EXISTING ROAD ENVIRONMENT

2.1 Site Location

The development site is located approximately 5 km west of the town of Finley in the Riverina area of NSW (refer Figure 1). The development site is in the Berrigan LGA and is not located within a REZ.

The development site for the Finley BESS project impacts land within Lot 3 DP740920 (private land under agreement by the Applicant), Lot B DP961693 (land hosting the Transgrid substation and owned by Transgrid) and the road reserves of Canalla and Broockmanns Road, Finley.

The portion of the development site hosting the BESS infrastructure is bounded by Canalla Road to the west and Broockmanns Road to the south. Lot B DP961693 fronts Broockmanns Road in the north and Canalla Road in the east. The development site is located on land zoned RU1 -P Primary Production under the *Berrigan Local Environmental Plan 2013* (LEP) Lot 3 DP740920 is used primarily for agricultural activities including irrigated agriculture and grazing.

The development site is generally cleared of vegetation due to historic agricultural activities, with remaining vegetation comprising a mixture of exotic grassland and limited native vegetation.

The Murray Valley National Park is located approximately 18km to the south-west.

The Finley Solar Farm is located approximately 400 metres to the south of the development site, Finley South Solar Farm is located to the south-east of Finley (approximately 12km from the development site), the proposed Berrigan BESS is located to the west of the site on the opposite side of Canalla Road, the Tarleigh Park Solar Farm.

The road network in the surrounding locality is depicted in **Figure 1**.

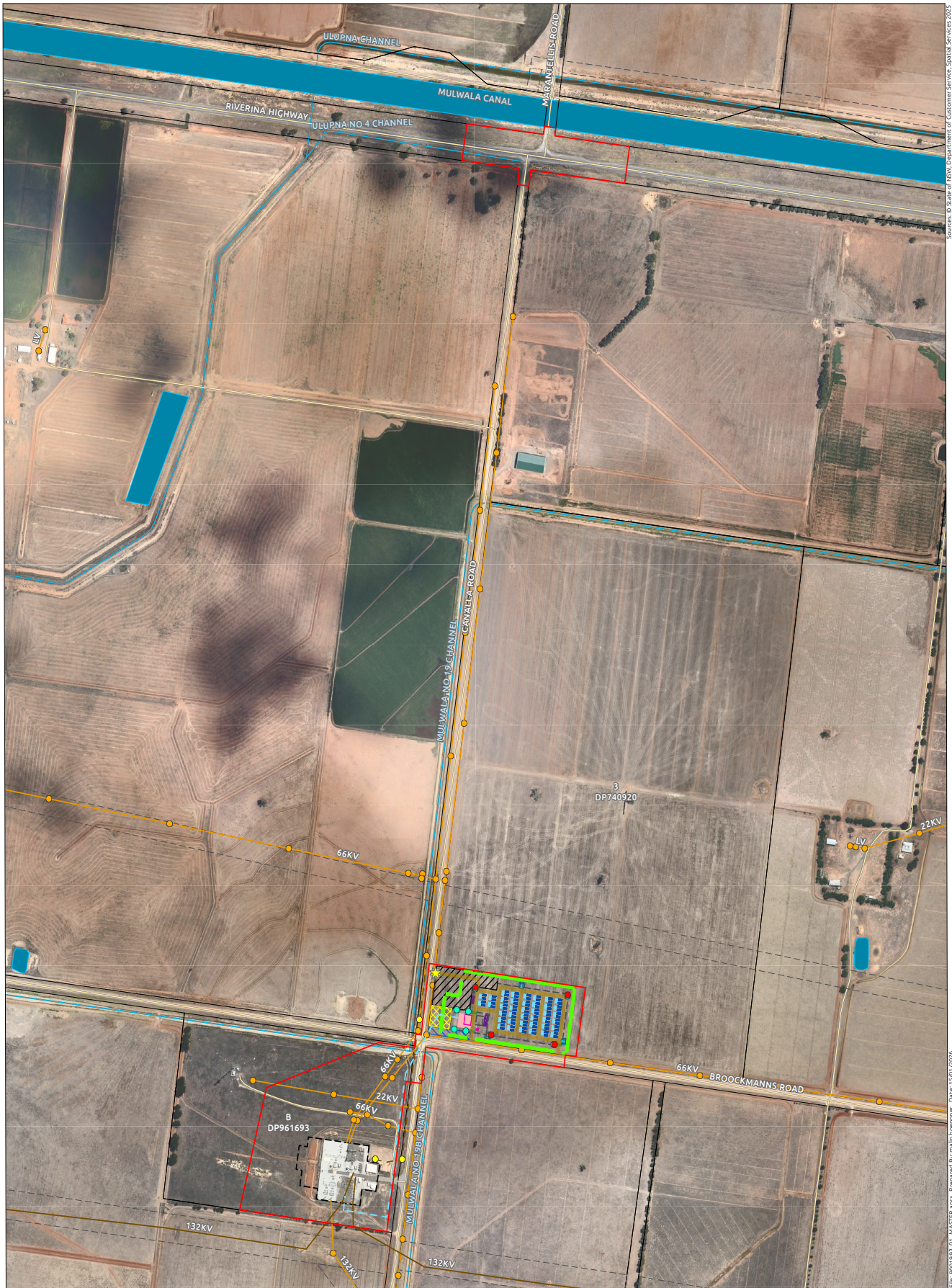

Sources: © State of NSW, Department of Customer Services, Spatial Services 2023
 © Geospatial Development, 2024, Yearmap 2023
 File: P001933_01_MASTER.aprx Prepared by: main.hobson@premise.com.au Date: 15/07/2024

- Legend**
- Development Site
 - ★ Primary Site Access (Heavy Vehicle)
 - Lot
 - Road
 - Water Body
 - Watercourse
 - Existing Infrastructure**
 - Existing Substation
 - Existing Easement
 - Essential Energy OH
 - Essential Energy UG
 - Transgrid OH
 - Transgrid Optic Fibre
 - Essential Energy Pole
 - Transgrid Pit
 - Proposed Development**
 - Substation Switch Area
 - Internal Road
 - Temporary Facilities**
 - Car Parking
 - Laydown
 - Site Offices
 - BESS Substation
 - BESS Buildings
 - Battery
 - Inverter
 - Gate
 - Fence
 - Screening Vegetation
 - Proposed UG Connection line
 - Watertank
 - CCTV Mast
 - BESS Lighting Mast



Finley BESS

Figure 1
Locality and surrounding road network

2.2 Road Network

2.2.1 KEY ROADS AND INTERSECTIONS

A summary of the key roads and intersections surrounding the site is provided below:

Table 4 – Key Roads

	Administrative Class	Legal Class	Note	Speed Limit
Riverina Highway	State	Classified	Road number 20	100 km/h
Canalla Road	Local	Unclassified	n/a	Rural Default 100km/h
Brookmanns Road	Local	Unclassified	n/a	Rural Default 100km/h

Table 5 – Key Intersections Surrounding the Site

Intersection	Intersection Type
Canalla Road / Riverina Highway / Marantellis Road	Staggered Three-way, sign controlled
Canalla Road / Brookmanns Road	Priority Controlled Four-way, sign controlled

2.2.2 TRAFFIC AND ROAD ENVIRONMENT

Riverina Highway is a State Road spanning 220km from Bethanga Bridge over the Murray River to the Cobb Highway at Deniliquin. In the vicinity of the development site the highway is a two-way, two-lane carriageway with 3.5 m wide traffic lanes in each direction and a speed limit of 100km/h.

Canalla Road and Brookmanns Road are both partially paved roads in a 20m road reserve providing connectivity for the rural areas south of Riverina Highway. Both roads have a speed limit of 100km/h which is unlikely to be achieved bearing in mind the roads are only partially paved.

2.2.3 HEAVY VEHICLE ACCESS ROUTES

Unrestricted operation of High Mass Load (HML) routes is allowed on certain designated routes, as determined by TfNSW and National Heavy Vehicles Regulator (NHVR). Permits required for other roads by TfNSW and/or the relevant Council.

Figure 2 shows available HML routes (for up to B-Double heavy vehicles) connecting to the project area and connection to relevant ports. The Riverina Highway is a designated HML route for up to B-Double heavy vehicles in vicinity of the development site and offers good connectivity to wider network of HML routes.

The Riverina Highway in this location is listed on the NHVR Restricted Access Route Map as being able to accommodate up to 26m B-Doubles and Class 1 OSOM vehicles.

Figure 2 - B Double (25/26m) network in vicinity of the development site (source: NHVR)

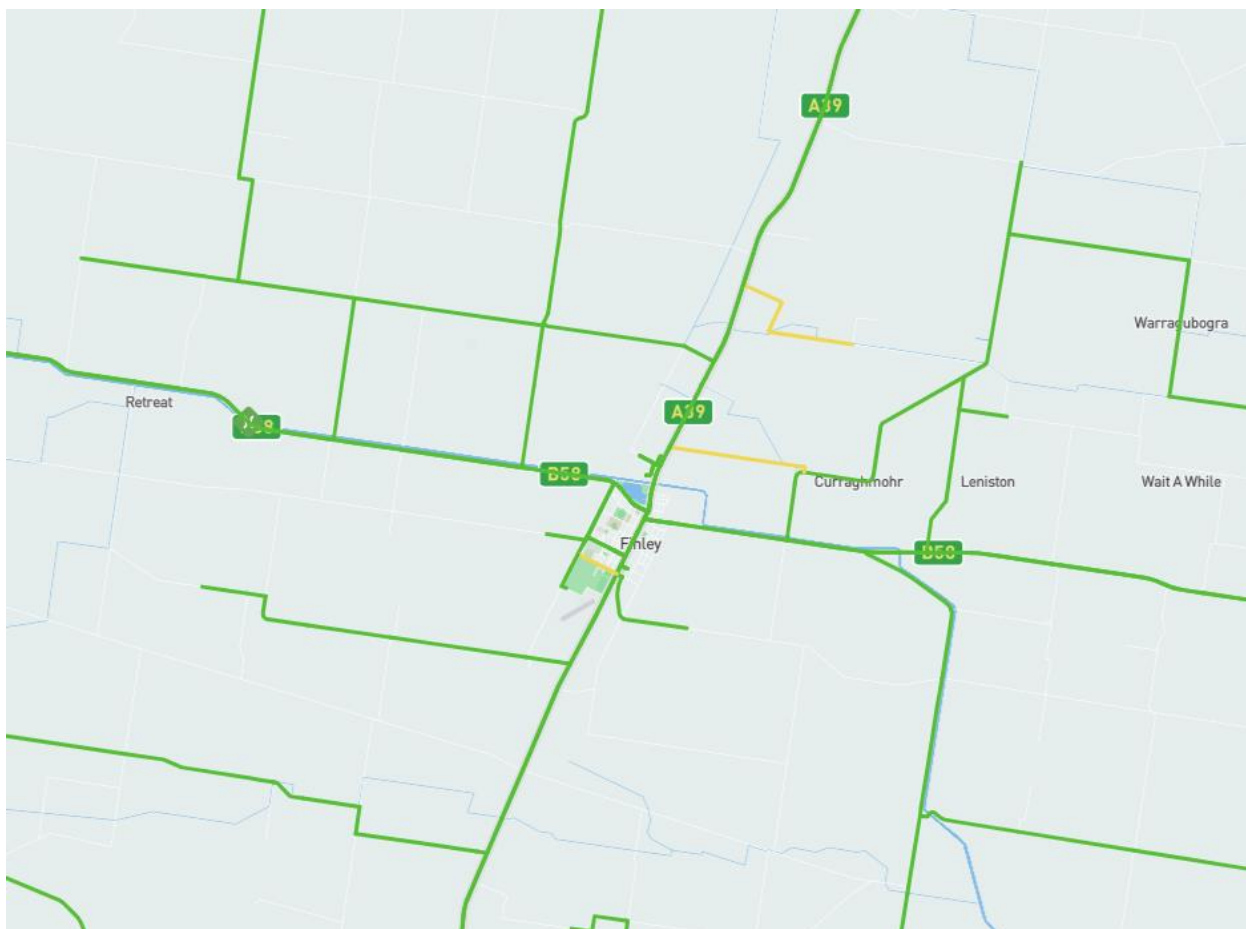

It is likely during construction that some larger vehicles will be required to transport large construction equipment and/or construction materials to the site and that these will exceed General Access (GAV) heavy vehicles sizes for the road network. For the purposes of this assessment, it has been assumed that any vehicles larger than these vehicles will be capable of meeting the Class 1 exemption for Oversize and Overmass (OSOM) load carrying vehicles. Given the applicant’s experience with other projects of this nature, this assumption is reasonable. The findings of OSOM Route Study, prepared by Ares Group are summarised in **Section 4 OSOM Vehicle Movements**.

Canalla Road is not a part of RAV or OSOM route, therefore separate applications will be required to enable access for these types of vehicles.

2.2.4 TRAFFIC VOLUMES

AADT data on Riverina Highway, sourced from the TfNSW Traffic Volume Viewer, 5km east from the proposed site access are provided in **Table 6** below.

Table 6 – 2011 AADT

Location	Average Annual Daily Traffic (AADT – veh/day)	Heavy Vehicles (%)	Mean Speed (km/hr)	85% Speed (km/hr)
Riverina Highway EB 110m West of Hamilton Street (2011)	764	18.8%	N/A	N/A
Riverina Highway WB 110m West of Hamilton Street (2011)	745	20.4%	N/A	N/A

The data available via TfNSW Traffic Volume Viewer is dated (older than 3 years) and located 5km from the development site access. Therefore, the Applicant commissioned Matrix to complete a 3-day traffic survey in period 18th to 20th February 2025. Data was collected at the intersection of Riverina Highway, Canalla Road and Marantellis Road for the AM and PM peak times.

Analysis of the provided data identifies the average peak hour times and traffic flows as outlined in **Table 7**.

Table 7 – Existing 2025 Peak Hour Traffic

Location/Direction	Time	Peak Hour Traffic (Veh/hr)		
		Total	Light Vehicles	Heavy Vehicles
Canalla Road northbound	Morning Peak - 08:00-09:00	1	1	0
	Evening Peak - 15:00-16:00	2	1	1
Canalla Road southbound	Morning Peak - 08:00-09:00	2	1	1
	Evening Peak - 15:00-16:00	0	0	0
Riverina Highway eastbound	Morning Peak - 08:00-09:00	57	46	12
	Evening Peak - 15:00-16:00	59	47	12
Riverina Highway westbound	Morning Peak - 08:00-09:00	53	38	15
	Evening Peak - 15:00-16:00	59	45	15
Marantellis Road northbound	Morning Peak - 08:00-09:00	1	1	0
	Evening Peak - 15:00-16:00	1	1	0
Marantellis Road southbound	Morning Peak - 08:00-09:00	2	2	0
	Evening Peak - 15:00-16:00	1	0	1

2.3 Public Transport Services

There are no public transport routes on Riverina Highway, Canalla Road or Broockmanns Road; however, an intercity coach runs on the Riverina Highway with stops in vicinity of Canalla Road intersection.



2.4 Pedestrian and Cycling Routes

There are no dedicated pedestrian or cycling facilities on Riverina Highway, Canalla Road or Broockmanns Road in vicinity of the subject site.

2.5 Development Site Access

Access to the site is from Riverina Highway via Canalla Road and Broockmanns Road, with entry/exit via three crossovers in total, one located in Canalla Road and two in Broockmanns Road.

All heavy vehicles will enter the via the proposed Canalla Road crossover.

A dedicated crossover will be constructed for Transgrid via Broockmanns Road in the west.

A dedicated crossover for light vehicles will be provided via Brockman Road in the east.

All internal roads will be constructed as all-weather roads, and provide profiles (i.e. widths) appropriate to the number and type of vehicle they provide access for. The final design of the internal road network will be determined further to discussions with the Principal Contractor prior to any construction works commencing.

2.6 Crash History

A review of the TfNSW Centre for Road Safety Crash and Casualty Statistics database for all injury crashes on the network in the vicinity of the site has been carried out. The crash database provides the location and severity of all injury and fatal crashes for the five-year period from 2019 to 2024. The crash search recorded 2 non-casualty crashes one on Broockmanns Road and one on Canalla Road, with the location of the crashes as shown in **Figure 3**.

Figure 3 - Road Crash History in vicinity of the subject site (2019-2023)

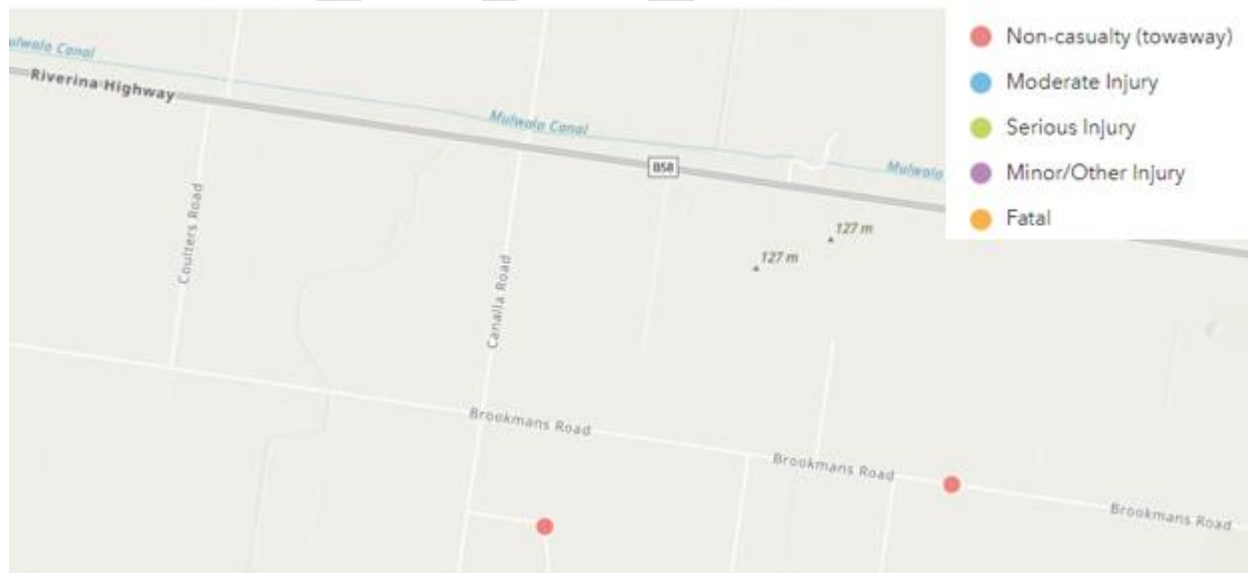

3. CONSTRUCTION OVERVIEW

3.1 Project Description

The project comprises three phases in general:

Phase 1 – Construction of the Project;

Phase 2 – Operation and Maintenance of the Project;

Phase 3 – Decommissioning or upgrading BESS and associated infrastructure.

This TMP will address specifically Phase 1 of the project.

It is expected that a separate TMP will be prepared for the Phase 3, closer to the commencement of the phase. During the operation, the traffic movements are anticipated to be minimal, therefore Phase 2 will be addressed in regular operating procedures.

3.2 Duration of Construction Works and Schedule

The Applicant has engaged a construction contractor to undertake a range of early works for the project, including development of a more detailed construction programme and associated updated assessment of equipment and material haulage, and hence traffic numbers and movements. Phase 1 of the works includes all of the following project construction activities:

- > Site establishment works including clearing of grassed area within the BESS boundary and transmission line (TL) footprint, bulk earthworks and temporary construction compound;
- > General fill and engineering fill for the construction of site access and internal roads and hardstand areas.
- > General fill and engineering fill for the construction of the substation bench and the roadway between substation and switchyard.
- > Other general imported fill materials.
- > Construction of hardstand, control room and switch gear, auxiliary transformer, battery enclosures, and inverter and transformer stations;
- > Development site road works to formalise internal access road to accommodate heavy vehicles movements including two accesses to Broockmanns Road;
- > Installation of approximately 80 x 20-foot modular containers comprising of Lithium-Ion batteries with the appropriate cooling and protection system and approximately 40 inverters (one per every two batteries) located externally to the modular containers;
- > Construction of 132 kV TL route ~480m length (underground TL) to facilitate connection to the existing Transgrid Finley 132/66 kV Substation and associated high voltage steel poles;
- > Construction of ancillary works including parking areas, water tanks, storage structures, stormwater management infrastructure, CCTV, security lighting, fencing and vegetation buffer; and
- > Transport of workers to and from the Site.

The construction (Phase 1) is expected to be completed in 10 months from the commencement. Prior to commencement, Munro Road will be upgraded and all the internal access ways constructed.

3.3 Construction Times

Construction times will be:

- > 7am-6pm Monday to Friday
- > 8am-1pm Saturday
- > At no time on Sundays or Public Holidays unless approved.

3.4 Workforce Transport

The TIA anticipates that at the peak of construction period there will be up to 55 workers required to construct the Finley BESS. It is anticipated that the contractor will seek to employ local work force where possible; however, some of the specialised workforce will be sourced externally to the local council administrative area.

3.4.1 WORKFORCE ACCOMMODATION

The workforce accommodation is subject to a detailed Workforce Accommodation Strategy; however, it is anticipated that the majority of the workforce will be sourced locally while some specialists may have to be accommodated locally in Finley.

Finley is approximately 5km west from the construction site, and a single trip is under 10 minutes long, depending on the traffic conditions. Minivan transporting workers to the site can feasibly bring in up to two rounds of workers (20 people) to the site in one hour.

If there are accommodation constraints in Finley, other feasible options could be Berrigan, Tocumwal or Deniliquin.

Berrigan is approximately 24km east from the construction site and a single trip is approximately 25 minutes long. Tocumwal is approximately 24km southeast of the construction site and a single trip is approximately 20-22 minutes long, while Deniliquin is 57km west of the construction site and a single trip is approximately 45 minutes long.

Under this arrangement, the Applicant will provide one (1) minibus accommodating up to 19 people on board for the commencement and finalisation of the construction, when the workforce is not at peak, and two (2) minibuses for the peak construction period.

3.4.2 WORKFORCE IN OPERATION (PHASE 2)

There will be approximately 2 FTE attending to the Finley BESS while operative. Employees will arrive in individual vehicles and will park on site.

3.5 On site parking

Throughout the construction period, parking on site will be provided to cater for:

- > Organised transport vehicles (minivans);
- > Individual passenger vehicles used by the construction workers;
- > Individual passenger vehicles for contractors and visitors to the site;
- > Heavy vehicles used by the construction workers;
- > Heavy vehicles delivering materials and components to the site.

Parking areas will be clearly designated depending on the type of the vehicle and the user class and will be allocated so that the dimensions of parking spaces and circulating aisles are not less than what AS2890 prescribes.

Deliveries of materials and components will be conducted as close to the place of installation as possible to minimise internal traffic movements.

Parking, inclusive of delivery areas, shall be organised to avoid heavy vehicles reversing, or to reduce the need to a minimum. Parking for passenger vehicles and minivans will be positioned so it is separated from areas of intense heavy vehicle traffic.

All contractors, visitors and employees will park on site, and not on local roads.

Upon completion, appropriate quantum of parking will be allocated on-site to the employees attending to the site throughout the operational phase.

3.6 Construction Vehicles and Equipment

Information provided by the Applicant regarding heavy vehicle movements is provided in **Table 8**. The information is used to prepare an updated Transport Impact Assessment (TIA) to support amendment of condition B1 of the development consent. Heavy vehicle movements occur over a 5.5 day working week and include the EPC’s and Transgrid’s heavy vehicles (Austroads Class 3 and above) used during the construction of the solar farm. While the anticipated timeline was adjusted to account for additional processes that took place since the TIA preparation, the vehicular estimates are as per the TIA.

Table 8 – Estimated heavy vehicle movements

Vehicle Type	Anticipated Trips	Anticipated Loads
OSOM Load	1 movement (2 trips) during entire project.	Transformer
Heavy – 12.5m to 20m HRV/Six Axle and B-Double	Up to 45 movements (90 trips) per day	Water trucks Containers Construction Material Construction Mobilisation
Long Loaders	Up to 5 movements (10 trips) per day	Culvert Material Excavator Bulldozer Grader Compactor Piling Rig

3.7 Traffic Movements – Phase 1 (Construction)

TIA provides estimate of traffic generated during the construction period based on the anticipated operations. The **Table 9** summarises cumulative traffic volumes anticipated during the construction, and it differentiates trips that will be generated during the peak construction times and on average during the construction period.



Table 9 – Estimates of Average Daily Vehicle Trip Generation at Peak Construction activity.

		Total	Light Vehicles	BUS	Heavy Vehicles+ long loaders
Construction AADT (Veh/d)		164	56	8	100
Operation AADT (Veh/d)		4	4	0	0

NOTE: VPD is Vehicle Trips per Day and VPH is Vehicle Trips per Hour

Table 10 – Peak Hour Traffic Generation for Proposed BESS during construction

	Total	Light Vehicles	BUS	Heavy Vehicles+ long loaders
Peak (Veh/hr)	33	19	4	10

Site peak traffic activity will not coincide with network peak traffic.

3.8 Proposed Mitigation Measures

Key proposed mitigation measures include:

- > The Applicant will provide a dedicated Heavy Vehicle crossover to Canalla Road, while additional two crossover will be provided to Broockmanns Drive for passenger and Transgrid vehicles.
- > The Applicant will ensure that the Contractor obtained all necessary permits for access of B-doubles and Class 1 OSOM vehicles on Canalla Road.
- > Traffic Management Plan will be implemented and adhered to with regular reviews and updates throughout the construction period.
- > Appropriate traffic management will be implemented at the intersection of Riverina Highway and Canalla Road to facilitate safe manoeuvring of escorted OSOM vehicles.
- > Traffic Guidance Scheme(s) will be developed by appropriately accredited professionals to address immediate requirements of work packages. Traffic Guidance Scheme(s) will be appropriately implemented, audited and periodically reviewed.
- > Travel and Access Management plan for construction-related traffic will be implemented as stipulated in the Transport Impact Assessment, relevant development consent conditions and this traffic management plan.

3.9 Operational Traffic Impact

Once the Finley BESS is operational, it will generate minimal daily traffic. Scheduled maintenance works are expected to be undertaken in regular intervals. The staffing level is anticipated to be 2 FTE staff members, therefore the site is expected to generate on average 4 vehicular movements per day.

All trips generated by the Finley BESS during the operational stage will be required to use the same designated access route as used during the construction stage.

As such, the minimal traffic generation of the Finley BESS during the operational stage would have no impact on the operation of the road network.



3.10 Decommissioning Traffic Impacts

General decommissioning tasks are likely to include:

- > BESS and associated infrastructure would be unbolted from concrete slabs and removed by crane onto transporters. All site infrastructure would be taken away from the development site for resale or to an appropriate recycling or waste management facility;
- > Underground services would be cut back to below ground level and capped, in agreement of landowners; and
- > The development site would then be rehabilitated to as possible to its original state and use for agricultural or other permissible purpose.

It is possible that the infrastructure may be upgraded rather than decommissioned and the lifespan extended, subject to necessary approvals and agreements with landowners. It is also possible that the site may be decommissioned sooner, subject to technology and project viability.

Many of these tasks are anticipated to require the use of similar vehicles to those used during the construction stage phase.

Similarly, deconstruction machinery may be better equipped for dismantling certain on-site infrastructure, potentially leading to a reduction in decommissioning staff numbers compared to the construction stage.

While it is therefore difficult to provide a reliable estimate of trip generation during the decommissioning stage, based on the available information it is expected that there would be fewer vehicle trips than during the construction stage. This aligns with the conclusion drawn from numerous traffic assessment of other solar farm projects across NSW and Australia.

Even if considering a worst-case scenario where decommissioning traffic volumes resemble those of the construction stage, the operation of the road network would only be impacted if background traffic volumes had substantially increased. Historical data on Riverina Highway suggest a relatively low traffic growth.

Detailed assessment of decommissioning stage traffic will be undertaken to support future TMP revisions.

4. OSOM VEHICLE MOVEMENTS

OSOM vehicles are anticipated only in Phase 1 (construction of BESS and potentially in Phase 3 (decommissioning) of the project. The following sections will focus on the OSOM traffic anticipated in Phase 1, as an updated TMP will be prepared closer time when decommissioning is required.

Riverina Highway is a part of OSOM network and allows for easy access of Class 1 OSOM vehicles from both directions.

Canalla Road is not a part of OSOM network or RAV network and will require appropriate permits to be in place to allow for access of OSOM vehicles.

An OSOM Route Survey report was prepared by Ares Group in January 2026. The report details outcomes of a desktop route survey, and this section will outline the summary of findings.

During the construction period, heavy vehicles, special purpose vehicles and Class 1 OSOM vehicles are likely to come from different directions; however, OSOM Route Survey focuses on the transformer transporter, as the largest vehicle that will access the site.

4.1 Design Vehicle

The report suggests that the required vehicle configuration is likely to include prime mover, low loader platform with dolly and goose neck, as shown in the **Figure 4**. If the weight of the transformer requires it, a push truck may be required; however, it is unlikely to impact the swept path impact analysis.

Figure 4 - The largest vehicle anticipated to access the site (source: OSOM Route Study, Ares Group, Jan 2026)

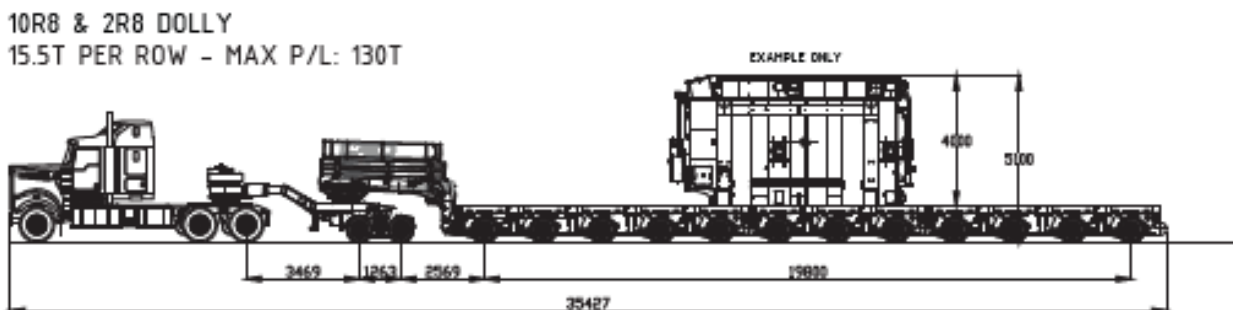

The load will be transported on a steerable platform trailer with dolly and hydraulic gooseneck. Overall dimensions are:

- > Length: 36m (excluding rear push truck)
- > Width: 4.2m
- > Height: 5.1m
- > Gross Combination Mass: 210 tons
- > Mass per Axle: 15.5 tons

The vehicle will be accompanied by three (3) pilot vehicles, operated by appropriately certified drivers.

4.2 Proposed OSOM Route

As the proposed port of import is Melbourne Port, the anticipated route is shown in **Figure 5** below. The route can be viewed via interactive link [Finley BESS OSOM Route](#).

Figure 5 - Proposed OSOM route for transformer transportation (source: OSOM Route Survey, Ares Group, January 2026)

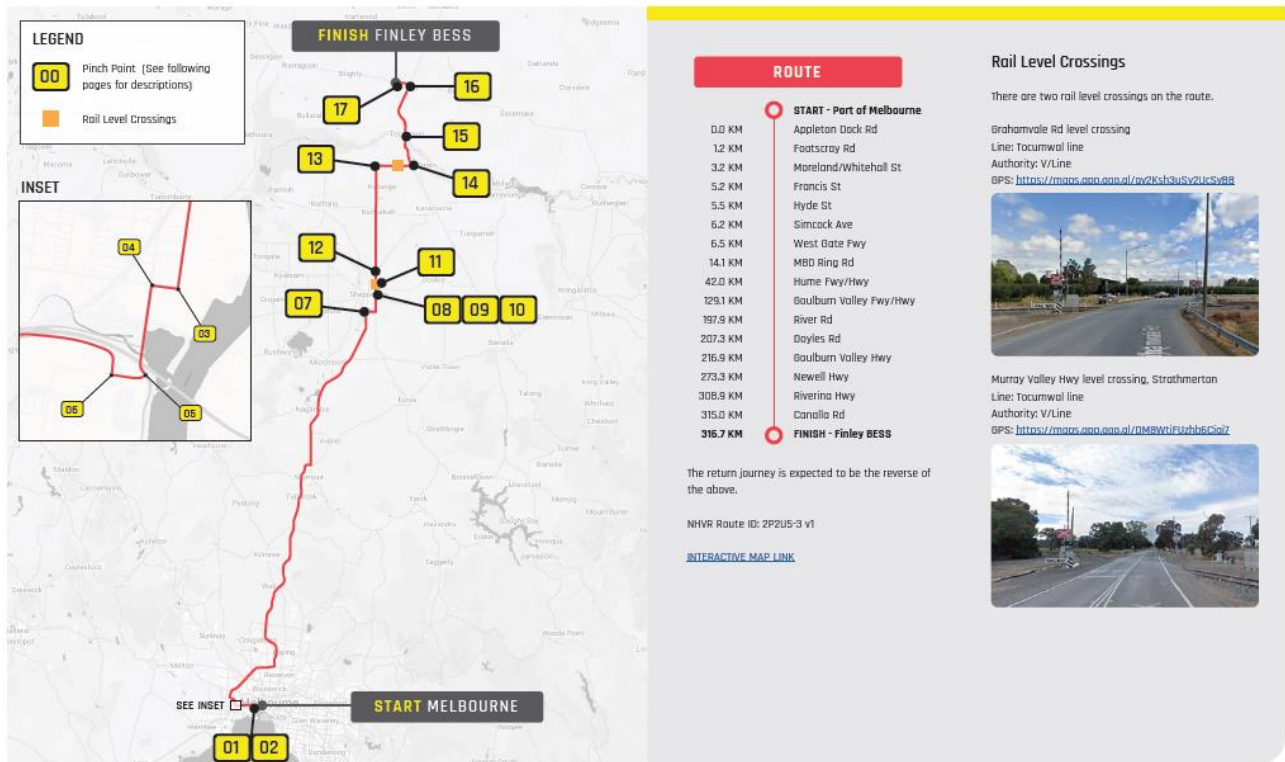

The route in principle follows approved OSOM Class 1 route (NSW and VIC), although liaison with relevant authorities will be required on sections of the route that allow for a conditional access. The geometric analysis identified following requirements for modification:

- > Pinch Point 07 – Right Turn Goulburn Valley Hwy & River Rd – one sign to be made moveable.

Based on the preliminary desktop assessment, the vehicle will require traffic management to complete following manoeuvres:

- > Left turn at Francis Street and Hyde Street;
- > Right turn from Hyde Street to Simcock Avenue;
- > Right Turn from Simcock Avenue to West gate FWY on-ramp;
- > Left turn from Riverina Hwy to Canalla Road.

The OSOM vehicle will likely traverse medians and splitter islands at following intersections:

- > Hyde Street and Simcock Avenue;
- > Goulburn Valley Highway/ River Road;
- > Riverina Highway and Newell Highway.

The heavy vehicle crossover on Canalla Road will be designed to accommodate movements of the largest OSOM vehicle.

The vehicle will require relevant permits from the National Heavy Vehicle Regulator (NHVR), state and local government authorities and from other relevant third-party authorities such as electricity/telco authorities, rail/tram authorities, toll road and tunnel operators. Closer to the day of transport a field survey will be required to confirm findings of desktop analysis.

The route is estimated to be approximately 320km long and as vehicles will be moving at slow speeds due to heavy load, it is anticipated that the inbound trip will be approximately 6-7 hours long. **Table 11** outlines proposed stops for fatigue management although other stops are available along the route if needed for emergency stops.

Table 11 - Proposed truck stops for fatigue management (source: OSOM Route Survey, Ares Group, January 2026)

No	KP	Rest Stop Name
01	62	Kalkallo Truck Parking
02	197	Kialla Rest Area
03	246	Numurkah Rest Area

4.3 Railway Crossings

There are two railway crossings on the route. Once the date of the transport is known and the details of cargo and required vehicles, approvals will be sought from V/ Line as the relevant authority.

Table 12 - Location of railway crossings (source: OSOM Route Survey, Ares Group, January 2026)

Crossing No 1	Crossing No 2
Grahamvale Rd level crossing	Murray Valley Hwy level crossing, Strathmerton
Tocumwal line	

4.4 Bridges and Culverts

Bridge assessments will still be required from the state road authorities (Victoria’s DTP and Transport for NSW) to confirm that bridges along the route can be crossed. Axle weights are proposed to be 15.5 tons per row.

A bridge assessment was conducted on 20 October 2025 for route 2NLNB-8 from Tocumwal to Finley. This assessment validates the capacity of the bridge to support the loads of the permit vehicle. The following conditions will be implemented at all bridge crossings along the route:

- > The vehicles travelling on all the bridges on the route at a speed not exceeding 10km/h with no sudden braking or acceleration.
- > No other vehicles are permitted on the bridge while the Permit vehicle is on the bridge
- > The vehicle shall travel only along the centreline of the carriageway of all the bridges.
- > The permit vehicle dolly and platform’s gross loading are to be equally distributed between all axles of the dolly and platform
- > Ensuring there is sufficient height clearance beneath all overhead structures along the route
- > The width of the vehicle and load can safely navigate all bridges on the route
- > No return trip is permitted



Figure 6 - General OSOM route overview with key assets (source: NHVR route planner)

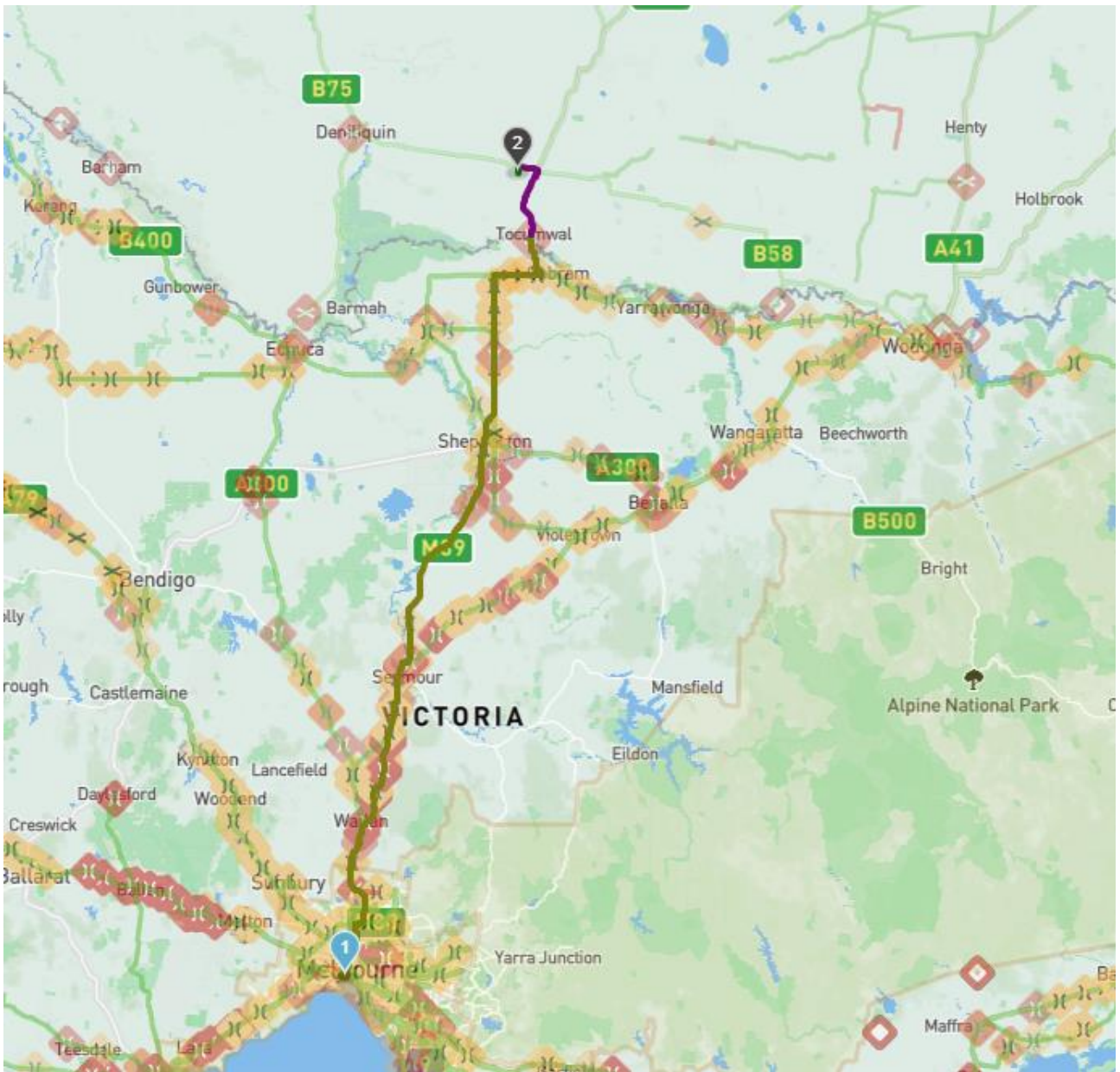

5. TRAFFIC MANAGEMENT STRATEGY

5.1 Driver Protocols

All drivers will be familiar with and operate their vehicles in accordance with Road Transport Act 2013, NSW road rules and Site Traffic Management arrangements. All drivers are required to read, sign, agree and abide by:

- > Current Traffic Management Plan, inclusive of any TGS;
- > Driver's Code of Conduct provided in Appendix of the TMP.

All drivers will hold current driving licences appropriate for the class of vehicle they operate. Drivers operating RAV or OSOM vehicles will respect the restrictions of the respective networks and any permits they may have to obtain. Drivers of fatigue-regulated vehicles will manage fatigue in line with NHVR rules.

5.2 Delivery Logistics

The applicant will designate staff responsible for managing access and departure of construction-related vehicles for the construction site. The deliveries will be planned to:

- > Maintain the number of daily and hourly (peak hour) arrivals in line with the Secretary's approval;
- > Schedule deliveries minimum 48 hours in advance;
- > Account as much as possible for any known roadworks;
- > Ensure that vehicles accessing the site have all necessary permits;
- > Avoid conflict with local traffic and particularly travelling through school zones at school pick up or drop off times;

The applicant will maintain a register of heavy vehicles accessing the site clearly showing:

- > Type of the vehicle;
- > Estimated time of arrival / Actual time of arrival;
- > Time of departure.

5.3 Information and Communications

The Principal Contractor will create a Communications Strategy that will be integrated into the TMP. This strategy will outline the effective communication methods to ensure that relevant authorities and the local community receive adequate information when necessary, and will enable the Principal Contractor to implement any construction-related traffic changes with minimal disruption to the vehicle environment both on and off-site.

The Communications Strategy will include the following elements at a minimum:

- > The installation of signs that provide advance notice of works and/or any traffic control measures, whether they are on or off-site;
- > Delivery of written notices to residents in the vicinity who might potentially be impacted by the construction works. These notices will be provided before the commencement of the works;
- > Regular project updates on the Project website and any associated social media channels; and

- > Provision of contact information for Principal Contractor (or their representative), enabling them to address enquiries from key stakeholders and local residents. Relevant contact details for the appointed contractor(s) for the Site will also be provided on the Project website.

5.4 On-site Mitigation Measures

5.4.1 STAFF PARKING

All staff parking, during construction and operation period, will be contained within the site; no staff (or any other) parking will be permitted off-site.

5.4.2 DELIVERIES AND MATERIALS HANDLING

All deliveries and materials handling will be confined on-site at all times; no off-site deliveries or materials handling will be permitted.

Set down areas will be clearly designated and, when feasible, separated from work areas, internal roads and car parks. These designated set down zones will provide for multiple trucks to be on-site at the same time. Additionally, these areas will be designed to ensure that the largest vehicle accessing the Site can manoeuvre within it safely, and that all vehicles enter and depart the Site in a forward direction.

5.4.3 TRUCK CONVOYS

Further to the above, careful management of deliveries will be undertaken to minimise the potential for truck convoys forming along the designated access route (as well as the broader regional road network), and to minimise any queuing at local intersections or at the Site.

Management strategies in this regard will include:

- > To the extent possible, scheduling of all deliveries so that they can be spread (to the extent practicable) across the work day (and over the broader construction stage) rather than being concentrated over short periods;
- > To the extent possible, the deliveries will be scheduled not to travel through school zones during the school pick up and drop off times;
- > For trucks delivering materials from the port, these trucks will be required to commence their journey to the Site immediately after being loaded. This means that movements are spread out (within the vicinity of the Site and broader regional road network), thereby mitigating the formation of convoys.
- > Given the distance between the ports and the Site, it is also anticipated that trucks will be spaced farther apart due to the varying traffic conditions prevailing across the broader regional road network.

5.4.4 EMERGENCY VEHICLE ACCESS

Continuous access for emergency vehicles to and from the Site will be ensured; the Principal Contractor will develop emergency protocols in the Emergency Management Plan for the construction stage. A separate Emergency Management Plan will be developed for the operational stage.



5.4.5 ON-SITE TRAFFIC MANAGEMENT

After determining the placement of internal access roads, set down areas and car parking within the Site, the Principal Contractor will develop a Site-specific Traffic Guidance Scheme (TGS) accompanied by appropriate operational policies. These will cover the following as a minimum:

- > A Traffic Flow Diagram showing all routes to/from the Site entrances and through the Site;
- > On-site speed limits;
- > Priority provisions, with larger vehicles to be provided with priority over smaller vehicles at all internal intersections at all times;
- > Car park locations;
- > Delivery set down locations and materials handling protocols;
- > Shaker grid and wash down facility locations;
- > Additional requirements such as the use of flashing hazard lights and reversing alarms, designated radio channels for on-site and off-site communication and adherence to the Drivers Code of Conduct (see also Section 5.8).

A copy of the relevant operational policies with site TGS will be provided to all construction staff as part of the Site induction process, and any changes will be communicated to all staff.

5.5 Oversize/Overmass Operating Protocols

During the Phase 1, OSOM and SPV will need to access the Site at specific points to bring in materials and/or machinery to the site. The Principal will ensure that The Principal Contractor will be responsible for ensuring full compliance with the requirements of the OSOM Permit, including the preparation of the OSOM Permit application.

Class 1 OSOM approved route is available between the Site and all key plant/equipment origins, with the exception of Canalla Road. All necessary permits are to be arranged for Canalla Road prior to arrival of OSOM vehicles.

OSOM vehicle operators will adhere to the Code of Conduct applicable to all drivers and furthermore, to fatigue-management practices as outlined by NHVR. Operators accessing the site for the first time will complete site-specific online induction prior to commencing the journey to the Site.

OSOM arrivals and departures to the site will be managed not to exceed approved levels, and the number of vehicles accessing the Site during construction will be logged.

Upon arrival to the site, the OSOM operators will adhere to the relevant operational policies and the Site-specific TGS. The operators will enter the site in forward gear, park in designated areas, and depart the site in forward gear. Site-specific Traffic Guidance Scheme will seek to avoid requirement for reversing manoeuvres for OSOM and SPV vehicles. If this cannot be avoided, use of spotters is mandatory.

5.6 Public Transport

The Applicant does not intend to use public transport.

All logistic and scheduling (in particular arrivals and departures of RAV and OSOM vehicles) will aim not to coincide with school bus travel times, if travelling to/from Finley.

The workforce will be transported in shuttle bus / mini bus Applicant-managed vehicles. The drivers will abide by the Driver's Conduct as outlined in this TMP.

5.7 Organised Workforce Transport Pick-up / Drop-off Locations

The Applicant seeks to transport non-local workforce in managed shuttle buses / mini vans. It is anticipated that up to 30 workers may require organised transport, resulting in up to 4 daily movements of shuttle buses at peak construction times (assuming buses are stored overnight at the project site).

It is anticipated that the buses will be picking up personnel in the morning in period 05:15-06:45 and drop the staff off in the afternoon in period 17:30-18:30.

There will be a designated parking area for shuttle buses / mini vans on site, positioned in such manner that it allows:

- > Passengers to safely approach the pick-up / drop-off area on foot;
- > Sufficient space for queuing of up to 19 people per vehicle;
- > Sufficient space for passengers to safely get in and disembark the vehicle.

The staff will be picked up at their respective accommodation venues. The routes of the shuttle bus will be known once the exact location of staff accommodation is known.

5.8 Special Events and Other Works

5.8.1 EVENTS

The Applicant and his contractors will monitor BSC's website for potential events that may occur during the construction period to ensure that the construction traffic will not compromise safety of these events.

5.8.2 OTHER WORKS AND PROJECTS

A review of BSC's website has not identified any future developments planned within the locality of the development.

A review of the NSW major projects planning portal application tracker, however, has identified several other state significant projects. Major projects within proximity are shown in Figure 10 and include:

- > South Coree BESS (SSD-77238990) proposed to be located immediately adjacent to the development site, with the corresponding BESS situated generally to the east of Finley BESS at 384 Broockmanns Road. This development application is currently in planning and awaiting the preparation of an EIS. The proposed layout for South Coree BESS, as presented in the Scoping Report prepared by NGH Pty Ltd (2024).
- > Berrigan BESS (SSD-78106206) proposed to be located immediately adjacent to the development site, north of Finley Substation, with the corresponding BESS situated generally to the west of Finley BESS, at 16891 Riverina Highway. This development application is currently in planning and awaiting the preparation of an EIS. The proposed layout for Berrigan BESS, as presented in the scoping report prepared by Cogency Australia Pty Ltd (2024).
- > Finley Solar Farm (SSD – 8540) which was originally approved on 29 January 2018 and is located immediately adjacent to the southwest of the development, south of Finley Substation. The solar farm received a subsequent approval for a modification for a substation upgrade on 4 June 2018 and is currently operational. The current approved layout for Finley Solar Farm, as presented in the latest modification application report prepared by ESCO (2018).
- > Tarleigh Park Solar Farm (SSD – 8436) which was approved on 18 May 2018 and is located approximately 25.5 km west of the development site at 260 Parfreys Road, Blighty.

- > Finley South Solar Farm (SSD-10299) located approximately 9.8 km southwest of the development site at 670 Lawlors Road, Finley. This development application was withdrawn following issue of the issue of SEARs dated 9 May 2019.

All other existing land uses surrounding the development site are expected to continue into the future. As detailed via the EIS the project design has been refined to limit impacts to surrounding land uses.

Two proposed adjoining developments (South Coree BESS and Berrigan BESS) will share the same access network (Riverina Highway, Canalla Road, Broockmanns Road); however, at present there is no evidence that the construction will occur on all three sites simultaneously. Furthermore, there is no data on anticipated traffic generation as EIS reports for these projects have not yet been submitted, as of writing of this report.

5.9 Hazardous Goods and Dangerous Materials

Risk Assessment identifies following Dangerous Goods to be stored on site:

Table 13 - Dangerous Goods to be stored on site

Area	Class	Description	Quantity
BESS	9	Lithium Batteries	1,372 T
Transformer Oil	C1	Combustible liquid	88 kL

The Principal Contractor will identify any other classified Dangerous Goods that may be brought to the Site during the construction process and will ensure these are appropriately labelled, stored, handled and disposed of.

Drivers transporting hazardous goods and dangerous materials must be familiar with the requirements of Australian Dangerous Goods Code or equivalent document at the time of transport.

The transported goods must be:

- > Appropriately packaged and labelled,
- > Appropriately segregated if there is a requirement;
- > Appropriately restrained for the transport;
- > Have all necessary accompanying documentation that driver can produce if required.

Every vehicle transporting dangerous goods and/or materials will need to be equipped with the following safety equipment as a minimum:

- > fire extinguishers in accordance with DGC Section 12.1.2; and
- > at least three portable warning devices that comply with AS 3790 and are clean and in good condition; and
- > personal protective equipment and safety equipment in accordance with DGC Section 12.1.3.

5.9.1 TRANSPORTING DANGEROUS GOODS

The Driver of vehicle transporting dangerous goods and all of the project-associated personnel involved in logistics and handling dangerous goods should be familiar with DGC. This section will outline key principles to be observed; however, the DGC must be referred to.



The transport routes should be preplanned and selected to:

- > Minimise the risk of personal injury or harm to the environment or property;
- > Where practicable avoid heavily populated areas or areas with high temporary concentration of people, narrow streets, tunnels, congested crossings or environmentally sensitive areas;
- > Comply with relevant requirements or restrictions on selected routes at the time of travel.

The vehicle transporting dangerous goods should not have passengers riding in the cabin apart from:

- > an authorised officer, police officer or officer of an emergency service, or a person authorised to ride in the vehicle by such a person; or
- > an employee of, or other person authorised to ride in the vehicle by, the owner of the vehicle or the prime contractor.

A road vehicle transporting dangerous goods must not be parked or left standing:

- > in a built-up area with public access; or
- > within 15 metres of any building in which there is or is likely to be a concentration of people (other than a building on premises where the vehicle is loaded or unloaded); or
- > at any other place in which there is or is likely to be a concentration of people; or
- > within 8 metres of another vehicle which is transporting placarded dangerous goods.
- > The exemptions to the abovementioned parking requirements are described in DGC Section 13.1.3.2.2.2.

In the event of breakdown, other road users must be alerted by:

- a. placing a portable warning device in a manner required by DGC Section 13.1.2.2; and
 - i. if the battery has not been disconnected to prevent danger and there are flashing hazard lights on the vehicle—turning the hazard lights on and leaving them on while the vehicle is stopped; or
 - ii. if the battery has not been disconnected to prevent danger and there are no flashing hazard lights on the vehicle—turning the parking lights on and leaving them on while the vehicle is stopped.

Subsequently, the Driver should follow the agreed breakdown procedure and inform relevant personnel.

In non-emergency situations, dangerous goods must not be unloaded from a road vehicle unless:

- > the consignee, or a person acting on the consignee's behalf, is present and receives the goods; or
- > if the driver, prime contractor or consignor has agreed with the consignee for the goods to be unloaded into a secure place, the goods are unloaded into that place.

5.10 Responding to Local Climate Conditions

The Applicant will develop an Emergency Response Plan (ERP) that would be in place throughout the life of the Project during construction and operation. Following sections outline basic principles pertaining to the construction period.

5.10.1 FLOODING

The EIS confirms that the Site is not identified as flood prone land, and that no specific flood mitigation measures are required.

Notwithstanding, the Principal Contractor will monitor weather conditions, particularly when warnings of severe or dangerous weather are issued that could jeopardise these roads or ongoing construction activities. After a severe weather instance, the Principal Contractor will inspect all internal road, Canalla Road and Broockmanns Drive to determine the suitability for use by construction vehicles. Should the severe weather incident occur during the construction hours to such extent it poses a risk to workers, driver and public on roads, the Principal Contractor will temporarily suspend vehicular movements until the weather conditions are no longer a safety risk.

5.10.2 BUSHFIRE

Section 6.11 of EIS notes that the Site is not mapped as bushfire prone land; however, certain characteristics of the site contribute to bushfire risk. The EIS recommends following measures to be undertaken during construction:

- > Design and construction – equipment will be sited in a way that will not contribute to bush fire risk and will minimise the impact of bush fires on the capabilities of the infrastructure during bush fire emergencies by:
 - Spacing between BESS container accumulations (i.e. 4 containerised units) shall be a minimum of 3 m to prevent fire propagation:
 - > End to end spacing (short side) of BESS containerised units shall be a minimum of 3 m; and
 - > Back to back spacing (long side) of BESS containerised units shall be a minimum of 3 m.
 - BESS containerised units are provided with the following emergency protection systems as specified by the BESS manufacturer;
 - > Smoke detector sensor;
 - > Heat detector sensor;
 - > Flammable gas sensor;
 - > Off-gassing valve;
 - > Explosion-proof valve;
 - > Water detector sensor;
 - > Fire strobe;
 - > Alarm bell; and
 - > All BESS containerised units can be shut down locally or remotely in an emergency.
 - Vents shall not be located above battery packs within the BESS container and will be constructed of non-combustible materials.
- > During construction and for the life of the project, a 10m Asset Protection Zone (APZ) will be provided around project-related infrastructure. Temporary construction and laydown areas, site access and associated fencing do not require specific APZ. The following vegetation management requirements apply in the APZ:
 - Trees will not be located within the APZ;
 - Shrubs will not be located within the APZ;

- Grass should be kept mown to a height of < 100 mm in height;
 - Leaves and vegetation debris should be removed to reduce fuel load;
 - Roads and paved/cleared areas are suitable within the APZ.
- > Landscape maintenance includes the APZ around infrastructure, the implementation of proposed vegetation screening and the ongoing management of the development site to reduce fire intensity and the rate of spread as it approaches structures in accordance with PBP 2019 and NSW planning guidelines.
- > On-site static water supply 75,000 L dedicated for firefighting purposes, strategically positioned within the development site and fitted with Storz fittings.
- > Main vehicular access, internal road network will provide for safe, reliable and unobstructed passage for firefighting vehicles and maintained for the life of the development, including:
- The trafficable surface has a minimum width of 4 m with 1 m traversable shoulders;
 - Minimum vertical clearance of 4 m in height to any overhanging obstructions;
 - Unsealed/sealed all weather traversable roads will be of suitable load bearing capacity, drainage structures and feature crossings;
 - Road grade to be less than 10°
 - Allow for two way traffic flow, with capacity for passing and turning areas, enabling safe ingress and egress to the development site.

A Bush Fire Emergency Management and Operations Plan (BEMOP) will be prepared to support emergency management for the Project ensuring bushfire protection mitigation measures are maintained, detailing:

- > APZ and landscape fuel load management;
- > Detailed measures to prevent or mitigate fires igniting;
- > Work that should not be carried out during total fire bans;
- > Availability of fire-suppression equipment, vehicular access and water;
- > Storage and maintenance of fuels and other flammable materials;
- > Notification of the local NSW RFS Fire Control Centre for any works that have the potential to ignite surrounding vegetation, proposed to be carried out during a bush-fire fire danger period to ensure weather conditions are appropriate;
- > Appropriate bush fire emergency management planning; and
- > Nominating an emergency meeting point, preferred evacuation route and methodology for ensuring all occupants are safe and accounted for.

The BEMOP will be developed in consultation with the local NSW RFS District Office and will be communicated to relevant stakeholders.

Regarding bush fire, the threat at the development site is considered low, being possible ember and smoke attack only assuming the APZ is maintained.

Further to the requirements of PBP 2019, the applicant will provide:

- > Ongoing training for all on-site personnel regarding bush fire response procedures;
- > Fire fighting training for operational workers; and
- > Operational vehicles will be fitted with basic fire fighting equipment.

The BAR concludes that bush fire risks have been thoroughly assessed and effectively mitigated through the implementation of the aforementioned mitigation measures.

5.10.3 DIRT AND DUST

If there is a potential for adverse air quality impacts to arise during the construction stage as a result of dust emissions from works involving the transportation of materials on internal roads, a Dust Management Plan will be developed and appropriate mitigation measures will be implemented during the construction stage, which will include:

- > Internal road and exposed dusty surfaces will be regularly wetted with a water cart;
- > Stabilising techniques and/or environmentally appropriate dust palliatives will be applied if wetting is not effective to the required standard;
- > The sealing the driveway in approach to the public roads;
- > Restricting vehicle movements and ground disturbance to the smallest feasible area that ensures safety;
- > Ensuring that vehicles leaving the Site are clean to minimise dirt tracking onto the public road network, further aided by wash down facilities and shaker grids at the [internal] approach to both Site entrances;
- > Applying strategic watering for dust suppression through strategic as required; and
- > Temporarily ceasing works during excessively dry and windy conditions, if required.

5.11 Emergencies

The Emergency Plan (EP), will set out the actions to be followed by site personnel and visitors in the event of an emergency, covering but not limited to:

- > Contact details and communication.
- > The type and location of emergency equipment.
- > Emergency preparedness and response.
- > Training.
- > Raising the emergency alarm.
- > Emergency evacuation procedures.
- > Testing and recording drills.
- > Fire water supply/fire response trailers.
- > Fire surveillance.
- > Flood response.

Should emergency occur on-route to the site, the Driver shall:

- > Stop the moving vehicle in the safe spot, if possible, and ensure it is secured and visible to the oncoming traffic;
- > Ensure they are standing in a safe location;
- > Call for relevant emergency service, if applicable;
- > Call for roadside assistance, if applicable;
- > Inform their manager and relevant logistic personnel of the emergency;
- > Wait for help in a safe location.



6. ROAD MAINTENANCE

It is anticipated that road dilapidation surveys for Canalla Road will be a condition of development consent in line with our recent experience on similar projects.

During the construction period Canalla Road will be regularly inspected for any construction-related activity damage. The Contractor will maintain accurate register of road inspections and findings detailing the extent of damage, date of inspection and mitigation strategies.

Upon completion of construction, the Contractor will repair Canalla Road mitigating any construction-related damage.

DRAFT



7. TRAFFIC MANAGEMENT RESPONSIBILITIES

7.1 Lead Project Manager

The Lead Project Manager will be responsible for:

- > Overseeing the implementation and maintenance of all traffic control measures outlined in this TMP, ensuring compliance with relevant Acts, Codes, Standards, and Guidelines.
- > Maintaining effective communication and consultation with affected stakeholders.
- > Organising regular inspections of traffic controls as per the TMP, recording results, and addressing any variations with proper documentation.
- > Reviewing feedback from field inspections, worksite personnel, and the public, organising necessary adjustments to traffic control measures with approval from the Responsible Authority.
- > Organising and/or conducting required audits and incident investigations.

7.2 Lead Construction Manager

The Lead Construction Manager will be responsible for:

- > Day to day implementation of TMP requirements;
- > Provide workers with instructions on relevant safety standards, including proper PPE usage.
- > Ensure that the TMP requirements are reinforced through the daily toolbox talks.
- > Ensure traffic control measures are implemented and maintained as per the TMP.
- > Conduct inspections and evaluations, submitting required reports to the Lead Project Manager.
- > Assist road users and stakeholders when work-related incidents impact network performance or compromise safety.
- > Evaluate received complaints and incident reports.
- > Address unsafe conditions by taking corrective action, including making necessary modifications to the TMP.

7.3 Workers and Subcontractors

The workers and subcontractors shall:

- > Go through the site induction and adhere to instructions received at the induction and at the daily toolbox talks (if applicable).
- > Use designated entry and exit routes, adhering to safe work practices at all times.
- > Park only in designated areas adhering to the parking procedures specified in this TMP and DCC.
- > Always wear required protective equipment (e.g., footwear, eye protection, helmet, sun protection, high visibility vest or shirt) while on the worksite.
- > Follow the TMP requirements and avoid any actions that could compromise the safety of workers or the public.

8. IMPLEMENTING TMP

8.1 Hazard Identification, Risk Assessment and Control

The general process for hazard identification and elimination involves several key steps.

First, a site-specific risk assessment must be conducted to identify all reasonably foreseeable hazards that could pose risks to health and safety. This includes analysing the work environment, reviewing historical data, and consulting with relevant stakeholders. **Table 14** below outlines some of the hazard categories to be considered in this context.

Table 14 - Potential hazard categories to be considered (source: TfNSW Manual)

Hazards and Risks	
Moving traffic	Traffic generating special events
Queued traffic	Non-compliance with temporary speed limits
High volume traffic	High volume traffic
High vulnerable road user activity	Compromised access points
Other construction activity or roadworks the in close proximity to proposed work site	Emergency vehicle access
Rising and setting of the sun	Rising and setting of the sun
Traffic speed and compliance behaviour	Horizontal (curves) and vertical (crests/sags) alignment
Traffic composition	Crash history
Number and location of traffic control points	Site vehicle access and egress points
Exposure and proximity of workers to live traffic	Topographical constraints
Length of delays for road users	

Once hazards are identified, they should be assessed in terms of their likelihood and potential consequences.

Figure 7 - TfNSW recommended risk evaluation matrix (source: TfNSW Manual)

Risk ratings: Very high VH High H Medium M Low L		Consequence					
		Insignificant C6	Minor C5	Moderate C4	Major C3	Severe C2	Catastrophic C1
Likelihood	Almost certain L1	M	H	H	VH	VH	VH
	Very likely L2	M	M	H	H	VH	VH
	Likely L3	L	M	M	H	H	VH
	Unlikely L4	L	L	M	M	H	H
	Very unlikely L5	L	L	L	M	M	H
	Almost unprecedented L6	L	L	L	L	M	M

The next step is to implement control measures following the hierarchy of controls framework, which prioritizes eliminating risks where possible, substituting them with safer alternatives, or implementing engineering controls. If elimination is not feasible, administrative controls and personal protective equipment (PPE) should be considered as additional layers of protection.

If required, administrative controls should be developed in accordance with Administrative Requirements Framework A Guide to NSW Government Administrative Requirements (NSW Government, 2022).

Figure 8 - Hazard control framework

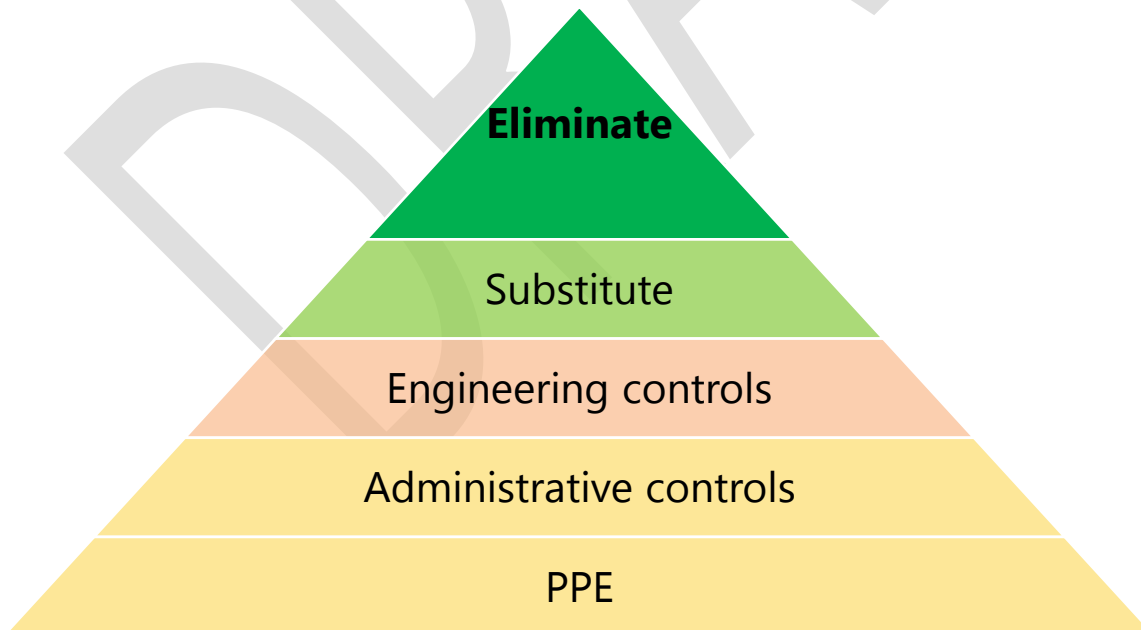

Finally, ongoing monitoring and review processes should be established to ensure that the implemented controls remain effective and to address any new hazards that may arise during the course of work activities.

8.2 Traffic Guidance Schemes and Road Occupancies

The construction process is expected to be eleven (11) months long with peak construction activity over 3 (three) months.

The Principal Contractor will develop and implement appropriate Traffic Guidance Schemes, prepared by WZTMP qualified person) to ensure that construction traffic does not compromise safety of the road network.

For the duration of the construction, the Principal Contractor shall review TMP and TGS in concurrence minimum once per week or immediately if an incident or near-miss was reported and make necessary adjustments.

8.2.1 ROAD OCCUPANCY LICENCES (ROLS)

A Road Occupancy Licence (ROL) is a permit that conditionally allows the holder to use or occupy a specified road space at approved times. It is typically required for activities that may affect the operational efficiency of the road network, such as construction, maintenance work, or any other activity that requires temporary traffic management on public roads. The ROL ensures that the necessary safety and regulatory requirements are met while minimising disruption to road users and maintaining safe access for emergency services and local traffic.

Depending on the final extent of works and the construction management plan, the Applicant may need to apply for ROLS on Canalla Road and Broockmanns Drive through the local government.

8.2.2 GENERAL DESCRIPTION OF CONSTRUCTION SIGNAGE TO BE USED.

Construction signage refers to a variety of signs used to communicate important information and instructions to road users, workers, and pedestrians in and around construction sites. These signs are designed to enhance safety by alerting individuals to potential hazards, guiding traffic, and providing directions. Common types of construction signage include warning signs (e.g., "Roadwork Ahead (T1-1)," "Detour (T5-1)"), regulatory signs (e.g., roadwork speed limits (R4-212n)), informational signs (e.g., project details), and directional signs (e.g., arrows indicating detours (T2-24)). Construction signs must be clearly visible, properly positioned, and made from durable materials that ensure visibility under various weather conditions. They should comply with relevant standards and regulations to effectively convey messages while ensuring the safety of all road users.

Internally to the site, the Principal Contractor will ensure that appropriate traffic guidance schemes are implemented to ensure safe traffic circulation.

8.2.3 TRAFFIC GUIDANCE SCHEMES FOR VARIOUS STAGES OF CONSTRUCTION WORKS

In addition to standard traffic management systems, the Principal Contractor will be required to organise or ensure the logistics company has organised active traffic management on Riverina Highway and Canalla Road to accommodate movements escorted OSOM vehicle transporting transformer from the Port of Melbourne. It is anticipated that the vehicle will be able to arrive to the site, unload the equipment and depart on the same day.



9. COMMUNICATING TMP REQUIREMENTS

9.1 Site Induction

All personnel entering the Site for the first time are to attend a Site Induction. The contents of the induction will depend on the job requirements for each staff member; however, core inductions will detail the requirements of the TMP, Occupational Health and Safety (OHS), risk management and emergency procedures. Typical TMP elements covered in the core induction are:

- > Safe and appropriate routes for accessing the Site via external network;
- > General traffic circulation internally to the site;
- > Site zones and parking areas, inclusive of loading and unloading areas;
- > Policies and procedures associated with traffic entering, departing and moving within the site.

The requirements of the TMP will be communicated to all personnel entering the site through the online induction prior to workers and visitors coming to the site, including the delivery drivers. The content of inductions should be tailored to suit the activities of individual.

9.2 Site Specific Traffic Guidance Scheme

The Principal Contractor will develop and implement a traffic guidance scheme specific to the construction site that unambiguously details:

- > Appropriate access location and access procedure;
- > Appropriate egress location and egress procedure;
- > Desired circulation for each class of vehicle internally to the site;
- > Allocated parking areas for each class of vehicle, inclusive of loading and unloading areas;
- > Appropriate pedestrian circulation.

Relevant signage is to be displayed so it is easily seen and comprehended.

The Traffic Guidance Scheme is to be regularly reviewed and updated if required with progressive construction phasing. Each update is to be reflected in updated inductions process and toolbox talks.

9.3 Toolbox Talks

Toolbox talks are safety briefings held at the commencement of every day or every shift or impromptu if there is a particular hazard that needs to be addressed. Core TMP elements are to be mentioned at every Toolbox Talks session, and particular attention should be drawn to any amendments to the procedures.

9.4 Safe Work Method Statements (SWMS)

Safe Work Method Statements are safety planning documents that personnel engaged in Site works (at any level) must review, understand and sign. Among other hazards, risk and safety elements, this document should reference basic TMP requirements enabling safe access to the Site and safe movement around the Site.

10. MONITORING AND MEASUREMENT

10.1 TMM Inspections, TMP Review, Audits and Record Keeping

10.1.1 REVIEW REQUIREMENTS

The TS 05492 requires that there are a set of mandated TTM inspections for long TTM schemes. These are as follows:

Table 15 - Mandatory TTM monitoring activities

Stage	Activity	Purpose
Planning	TGS verification	To ensure that the TGS selected or designed is suitable for the works and location
During TTM	Weekly TTM inspections (includes preopening inspection)	To ensure that the TMP and relevant TGS are appropriate and operating safely, effectively and efficiently
	Shift TTM inspections	To ensure that the TGS is implemented as designed. This includes at a minimum, twice per shift and when: A TGS is installed, changed or updated; At regular frequency after work commences, recommended every 2 hours; and Once aftercare arrangements have been installed if required
	TMP review	To ensure that TMP controls are achieving the required outcomes.
Post Completion	Post-completion inspection	To ensure that the site has been demobilised as planned and is safe for opening to traffic

Furthermore, the Client may inspect TTM for the duration of TTM for internal OHS purposes or similar. Road Safety Audits may be required to identify crash potential or risks that may lead to road incidents.

TMP must be reviewed after reported near miss, reported traffic-related incident or if the change in operations necessitates the change in TTM.

10.1.2 RECORD KEEPING REQUIREMENTS

TTM inspection records must record as a minimum:

- > Reference to the TGS that was used and inspected;
- > The start and finish times and location/s of the works;
- > The date and time of the inspection;
- > Any deficiencies identified and corrective action taken;
- > Detail of adjustments and modifications made and by whom;
- > Name of person authorising any modifications;
- > Any near misses;
- > Time of next shift TTM inspection;
- > Name of the ITCP qualified person who implemented the TGS;
- > Weather conditions and
- > Details of on-site traffic controllers;

As per State Records Act, the records must be retained for a minimum of seven (7) years. Apart from basic information such as date and location of TTM, reference number for TMP or TGS and details of responsible personnel, TTM documentation must include as a minimum:

- > Approved TMP developed for the works;
- > Completed risk assessments;
- > Approved TGSs used, including versions where modifications or updates have been made;
- > Other relevant documentation including staging plans;
- > Completed inspection checklists;
- > inspections, reviews and audits;
- > Records of traffic related incidents that occurred during the works;
- > Any departures, and approvals of departures from the Technical Manual TS 05492 and relevant Australian Standards; and
- > Any other relevant document generated by the process of completing the TTM works.

10.2 Incidents and Non-Compliances

10.2.1 DEFINITIONS

A non-compliance is typically defined in the Development Consent as an occurrence, set of circumstances or development that is a breach of this consent but is not an incident.

An incident is typically defined in the Development Consent as a set of circumstances that causes or threatens to cause material harm to the environment.

Material harm involves actual or potential harm to the health or safety of human beings or to ecosystems that is not trivial, or results in actual or potential loss or property damage of an amount, or amounts in aggregate, exceeding \$10,000 (such loss includes the reasonable costs and expenses that would be incurred in taking all reasonable and practicable measures to prevent, mitigate or make good harm to the environment).

Following any potential non-compliance or incident, the Applicant and its contractors will immediately conduct an investigation, at a level commensurate with the severity, to determine whether a non-compliance or incident has occurred, and then implement the relevant response protocol.

10.2.2 CORRECTIVE ACTIONS

Any non-compliance or incident will trigger a Corrective Action appropriate to the significance of the effect of the non-compliance. The Applicant will retain documented information as evidence of the nature of the non-compliance and subsequent actions taken, and the results of the Corrective Actions.

10.2.3 NON-COMPLIANCE RESPONSE PROTOCOL

In accordance with typical Development Consent Conditions, NSW Planning will be notified in writing via the Major Projects website within seven days after the Applicant becomes aware of any non-compliance. The notification will:

- > Identify the development and the application number.
- > Set out the condition/s of Development Consent that the Project is non-compliant with.
- > The way in which it does not comply.
- > The reason/s for the non-compliance (if known).
- > What actions have been, or will be, undertaken to address the non-compliance.

A non-compliance which has been notified as an incident does not need to also be notified as a non-compliance.

10.2.4 INCIDENT RESPONSE PROTOCOL

In accordance with typical Development Consent Conditions NSW Planning will be notified in writing via the Major Projects website immediately after the Applicant becomes aware of an incident. The notification will:

- > Identify the development and the application number.
- > Provide details of the incident (date, time, location, a brief description of what occurred and why it is classified as an incident).
- > Identify how the incident was detected.
- > Identify when the applicant became aware of the incident.
- > Identify any actual or potential non-compliance with conditions of consent.
- > Describe what immediate steps were taken in relation to the incident.
- > Identify further action(s) that will be taken in relation to the incident.
- > Identify a project contact for further communication regarding the incident.

A traffic related incident should contain further information:

- > Type, size and location of signs and devices in use at the time of incident;
- > Travel path width and road condition;
- > Weather conditions;
- > Witnesses present;
- > Details of any personal injuries; and
- > Extent of any vehicle damage and the vehicle details (e.g. registration).

A detailed incident report will also be provided to NSW Planning within 30 days of the incident date (unless otherwise agreed to by the Planning Secretary), including:

- > A summary of the incident.
- > Outcomes of an incident investigation, including identification of the cause of the incident.
- > Details of the corrective and preventative actions that have been, or will be, implemented to address the incident and prevent recurrence.
- > Details of any communication with other stakeholders regarding the incident.

10.3 Complaints Management

10.3.1 MEANS OF MAKING A COMPLAINT

The following contact details are available for the community to make a complaint or send an enquiry:

- > Project website: TBC
- > Email: TBC
- > Facebook: TBC
- > Community information telephone line: TBC

These details are provided on the Project website. They would also be published in a local newspaper where needed and are displayed on the Project sign in a publicly accessible location outside of the site.

10.3.2 COMPLAINTS REGISTER

Any complaint received will be logged in the Project Complaints Register, which is updated as required by the Applicant's Community Liaison Officer and is shared between key members of both the Applicant and the Contractors.

The Complaints Register will record:

- > The date and time of the complaint.
- > The means by which the complaint was made (e.g. telephone, mail or email).
- > Any personal details of the complainant that were provided, or if no details were provided, a note to that effect.
- > The nature of the complaint.
- > Any actions taken in relation to the complaint, including timeframes for implementing the action.
- > If no action was undertaken in relation to the complaint, the reasons why no action was taken.
- > The status of the complaint (i.e. open or closed).

10.3.3 COMPLAINT MANAGEMENT

As soon as practicable the Applicant will investigate the cause of the complaint and identify actions required to avoid a recurrence. Regardless of the circumstance, this initial response will be completed within 48 hours of receiving the complaint.

If so requested when the complaint was received, the Applicant or the Contractor (where relevant) will also contact the complainant to discuss the issue and cause, advising them of the actions taken to avoid a recurrence and any applicable timeframes for resolving the complaint.

Contractors and Transgrid will support the Applicant where appropriate in the reporting, understanding and resolution of disputes.

10.3.4 DISPUTE RESOLUTION

If the actions taken to address a complaint, including the measures for avoiding a recurrence, are not sufficient to satisfy the complainant and a dispute arises, the Applicant will do the following:

- > Advise NSW Planning that there is a dispute.
- > Provide NSW Planning with copies of the relevant complaint history.
- > If determined necessary by NSW Planning, engage a specialist with expertise relevant to the issue at hand to investigate the dispute and provide recommendations for resolution.
- > Advise the third party in dispute (the complainant) and NSW Planning in writing, as to when the dispute investigation will be completed.
- > Provide the third party and NSW Planning a copy of the dispute investigation report, inclusive of the Applicant’s intentions with regards to the implementation of the recommendations for resolution.

10.4 Management and Monitoring Summary

Regular site inspections will be conducted to ensure compliance with the EMS, supporting environmental plans, and general environmental obligations.

EPC Contractor and its subcontractors will conduct environmental monitoring across most of site. Transgrid will conduct monitoring associated with the switchyard.

During construction, EPC Contractor and Transgrid will maintain their respective inspections records and provide these to Applicant as required. Ultimately, Applicant will maintain inspections records for the whole Project and provide these to NSW Planning if requested.

Table 16 summarises the monitoring that will be conducted during construction in active construction areas. The frequency of monitoring may increase where environmental risk is elevated in some cases.

It is expected that monitoring will reduce following the completion of Stage 1 construction and transition into Stage 2 operations. Accordingly, this table will be reviewed prior to Stage 2 operations commencing.

Table 16 - Site Inspection and Monitoring Frequency Matrix

Aspect	Topic	Frequency (Stage 2 Construction)		
		Daily	Weekly	Monthly
Traffic	Traffic controls		✓	
Traffic	Dirt on road		✓	
Heritage	Unexpected finds protection			✓
Biodiversity / Land Management	Fencing and Gates			✓
Biodiversity	Native Fauna			✓
Biodiversity	Weeds			✓
Noise	Noise minimisation			✓

Aspect	Topic	Frequency (Stage 2 Construction)		
		Daily	Weekly	Monthly
Dust	Wind and blown dust	✓		
Soil and Water	Erosion and sediment controls	✓ (before/after storms)	✓	
Soil and Water	Creek crossings and culverts			✓
Waste	Rubbish		✓	
Hazards	Fire risk management	✓ (during high-risk days)		✓

DRAFT



11. MANAGEMENT AND REPORTING

11.1 TMP Review and Improvement

Given the timeframe for completion of this project, the Lead Project Manager will review the effectiveness of the TMP on weekly basis and update the document if required.

11.2 Variations to Standards and Plans

All of the plans, procedures and TGS will be in line with the current relevant standards. Should any departures occur, these should be in line with the TS 05492 - Traffic control at work sites. This document does not allow for departures from Road Occupancy Licences (ROL) processes.

Table 17 - Managing Departures in accordance with TS 05492 - Traffic control at work sites

Departure	Example of Departure	TS 05492 Relevant Section
Use of unapproved signs – includes variation to existing sign designs or the introduction of a sign that is not contained with the Traffic Signs Register	<ul style="list-style-type: none"> > Modification of an existing sign design within the Traffic Signs Register; or > Development of a new sign specific to site activity 	Section 2.8.2 Use of unapproved signs
Use of unaccepted device – includes the introduction of a device or innovative process that is not already accepted for use via this Technical Manual	<ul style="list-style-type: none"> > Use of a new or varied device for controlling traffic; or > Use of new or varied to delineation method 	Section 2.8.3 Use of unaccepted devices
General departures – refers to a variation to a mandatory requirement in this Technical Manual that does not fall into a 'sign' or 'device' category	<ul style="list-style-type: none"> > Variation to the approved minimum lane width; or > Variation to the approved minimum edge clearance /shoulder width 	Section 2.8.4 General departures

Any proposal to use unapproved signs or unaccepted devices must be approved by TfNSW. Procedure for seeking approval to General Departures from TfNSW is as follows:

1. Following the framework of Section 3.3.4 Risk assessment, the PWZTMP qualified person must undertake a risk assessment which includes:
 - a. Description of the work where departure is required;
 - b. Mandatory requirement not being met with detailed description why it cannot be met;
 - c. Options investigated;
 - d. Proposed variation to the requirement, including if the variation is:
 - i. Aligned with an accepted and existing national practice document, such as AS 1742.3 or the AGTTM;
 - ii. Aligned with an accepted and published standard of another Australian road authority; or



- iii. A risk based departure with no alignment to another standard or practice.
 - e. Risks introduced as a result of the proposed variation;
 - f. Additional controls needed to manage the introduced risks; and
 - g. The residual risk after the proposed variation and mitigation measures are applied.
2. Based on the anticipated residual risk and proposed standard applied, the PWZTMP qualified person must seek approval for the variation from the relevant Transport representative. Where the residual risk is determined to be:
 - a. Low to Medium – a Transport representative with authority at least Delegation 5 or higher (4, 3, 2 or 1) is required to approve the variation;
 - b. High – a Transport representative with authority at least Delegation 4 or higher (3, 2 or 1) is required to approve the variation.
3. After approval, the PWZTMP qualified person must update the TMP and other relevant documents such as traffic staging drawings and TGS in accordance with Section 8.2 Record keeping of TTM documentation. The TMP must include:
 - a. A copy of the approved risk assessment;
 - b. A summary of the departure including:
 - i. Description of the work where departure is required;
 - ii. Mandatory requirement not being met;
 - iii. Detailed reason for the requirement not being met;
 - iv. Options investigated;
 - v. Approved variation;
 - vi. Minimum controls needed to manage the introduced risks; and
 - vii. Supporting information such as drawings and correspondence etc.

11.3 Update of Strategies, Plans or Programs

The Applicant must review and, if necessary, revise the strategies, plans, or programs required under the Development Consent to the satisfaction of the Planning Secretary within one month of specific triggers such as incident reports or audit submissions, in line with the relevant development consent condition.

Furthermore, in line with a relevant development consent condition, with the approval of the Planning Secretary, updates can be submitted on a progressive or staged basis. The Applicant is also responsible for ensuring that all development activities are covered by suitable strategies, plans, or programs at all times, and any revisions must clearly describe the specific stage they apply to and the relationship to future stages.

11.4 Notification of Department

The Applicant must notify the Department of the date of commencement and the date of completion of each project phase involving commencement of construction, operation or decommissioning of the project. Should the project phase cease or be conducted in stages, the Department will be notified in the same manner.

APPENDIX A

DRIVER CODE OF CONDUCT

DRAFT



1. APPENDIX A - DRIVER CODE OF CONDUCT

1.1 Introduction

1.1.1 GENERAL

This driver code of conduct applies to all project personnel and any other person conducting business for on behalf of the Finley BESS or any works associated with the Finley BESS, whether a direct employee or a contractor or sub-contractor of the project. This code of conduct applies to all light and heavy vehicle drivers, and OSOM drivers, and they are all required to read, agree to and sign Driver Code of Conduct (DCC).

The Driver Code of Conduct will be communicated to all project personnel, contractors and visitors during the induction process; and will be regularly reinforced weekly in toolbox meetings, where applicable.

We are all members of the general community, so you are expected to comply with all the relevant legal requirements and accepted community standards whilst conducting your business. Whether you are directly employed by the project or operate any service to the company, your behaviour on the road reflects upon the community reputation of the project and in this regard your full compliance with this Driver Code of Conduct is required.

Project manager and the Contractor will keep the copy of the DCC, share it with all relevant suppliers and logistic companies visiting the site in any capacity, and will maintain all relevant records, as prescribed by the DCC.

1.2 Driving Practices

1.2.1 SAFE DRIVING PRACTICES

The operators of all vehicles accessing and egressing the development site shall respect all other road users. All on-site staff will receive a site induction, which will include, but not be limited to:

- > Details of the Traffic Management Plan and the Drivers' Code of Conduct, rights and obligations specified in these documents;
- > Confirmation of Blood Alcohol Concentration (BAC) and/or Narcotics testing at the gate;
- > Details of Traffic Guidance Schemes, inclusive of speed limit signs, appropriate routes of access and egress, appropriate parking locations for each type of vehicle;
- > Information on fatigue management;
- > Reinforcement that they must drive to conditions at safe speeds and not exceed speed limit while carrying out tasks associated with the development;
- > Reinforcement of correct and lawful use of mobile phones and GPS or other screens while operating a vehicle.
- > Details of vehicle inspections including maintenance records and risk assessments;
- > Details of inspections, and audits; and
- > Incident reporting, investigation and response protocols.

Key aspects of safe driving practices will be reinforced during the weekly toolbox meetings, with specific topics tailored to address current safety and incident records.

Contractors regularly visiting the site during the construction will receive full site induction; while occasional visitors will receive appropriately scaled site induction, as defined by the Construction Management Plan.

1.2.2 ESSENTIAL DRIVER CODE

At all times, the Driver will:

- > Obey all laws and regulations and do not drive carelessly or dangerously, overtaking only when it is legal and safe to do so;
- > Not drive whilst under the influence of alcohol, drugs, nor any medication which may affect ability to drive.
- > Be medically fit to drive. The Driver must inform site coordinators if they have any medical condition which may affect their ability to drive.
- > Drive in a considerate manner and respect the rights of others to use and share the road space.
- > Drive to road conditions, but within legal speed limit.
- > Report all vehicle defects to their employer. Serious defects (e.g. e.g. brakes, steering) must be corrected immediately, or an alternative vehicle supplied.
- > Report to police any vehicle incident resulting in injury or significant damage to property.
- > Report any near misses to the development site coordinator and to their employer.
- > Always adhere to the site working hours and any particular logistics arrangements. The Drivers travelling on RAV or OSOM routes with time restrictions must obey these restrictions, if applicable to their vehicles, in addition.
- > Schedule deliveries to avoid travelling through school zones at peak times and platooning through urban areas and on roads with steep grades.
- > Securely fasten and/or cover load with the appropriate use of ratchets straps, tarpaulins or covers (loose material), chains and load binders, for example.
- > Not exceed relevant load limits. Loads are to be suitably balanced. The maximum rear overhang shall not exceed limits under by relevant road rules for respective vehicle types.
- > Keep their vehicle clean and in good mechanical condition to reduce the environmental impact.
- > Take additional care when driving at dawn or dusk, being particularly watchful for wildlife and/or livestock.
- > Give way to pedestrians, cranes, forklifts, mobile plant, emergency vehicles and livestock.
- > Always adhere to the required access routes outlined within the TMP (**Section 2.2.3** and **3.9** of the TMP).
- > Reduce their speed in accordance with the law when:
 - Passing children walking, cycling or waiting on the side of the road;
 - Passing an oncoming school bus;
 - Passing near seniors housing or seniors crossing point;
 - Passing someone riding or leading a horse along the road;
 - Approaching an area where a stock shift is known to be occurring.
- > Will not use engine brakes in built up areas, if driving heavy vehicles, except where the load being carried and the grade of the road make use of such braking absolutely necessary for safe driving;
- > Let traffic behind them pass at regular intervals, if driving slow moving vehicles causing traffic to bank up. The Driver of slow-moving vehicle will pull over where safe and appropriate (at locations such as rest stops, road widening etc) to allow faster moving traffic to bypass them.

- > Manage fatigue appropriately by making regular stops in locations specified in the TMP (**Section 4.2** of the TMP) and maintain work diary as per NHVR regulations.

1.2.3 DEFENSIVE DRIVING

The Driver should always drive in a manner that will help them to avoid an accident, despite incorrect/inappropriate actions of others or poor driving conditions. Defensive driving requires a high degree of anticipation.

1.2.4 HIGHWAY COURTESY

The on-going reputation of the company depends very much on the way the Driver operates their vehicle and courtesy that you extend to the community. The road is there to share and therefore, it is a company requirement that the Driver displays courtesy and restraint towards other road users.

1.2.5 FINLEY BESS WORKS SPEED RESTRICTIONS

The FINLEY BESS site has a general speed limit of 40 km/h with 10 km/h limits in designated areas or as otherwise signposted. These limits are to ensure the interaction between personnel and vehicles are managed to minimise the risk of injury to all personnel.

Drivers are always required to observe the posted speed limits and other traffic signage. All incidents where drivers do not observe speed limits and other traffic instructions will be logged and investigated and, where appropriate, disciplinary action will be taken.

Drivers shall always follow posted signs as they provide vital clues to road conditions and characteristics. Following rules shall be applied:

- > Drive to road and weather conditions - always reduce your speed in wet conditions;
- > Drive cautiously in fog or heavy rain;
- > Descend hills at sign-posted truck speeds, or in the lowest gear to suit the conditions;
- > Always observe the special limits that apply for road works etc;

1.2.6 FATIGUE MANAGEMENT

Fatigue is one of five (5) leading causes of casualty crashes in Australia. Fatigue includes, but it not limited to:

- > feeling sleepy;
- > feeling physically or mentally tired, weary or drowsy;
- > feeling exhausted or lacking energy;
- > behaving in a way consistent with the above.

As the Drivers' capacity to react to changing road environment is reduced when the Driver is under fatigue, the crash risk increases significantly, highlighting the importance of fatigue management.

Drivers travelling more than 100km in one direction or spending more than 4 (four) hours driving in the course of their working day must have Journey Management Plan.

Journey Management Plan should contain following details:

- > Assessment of a senior officer, or a direct superior, if the driver is mentally and physically capable of the driving task;

- > Details of the trip (timing and duration); expected departure and return times;
- > Details of the driver and all passengers;
- > Details of the emergency contacts;
- > Route definition;
- > Anticipated weather and traffic reports;
- > Details of known hazards on route;
- > Pre-start vehicle checks;
- > Plan of rest stops and refuelling with no more than 2 hours of continuous driving;
- > Regular communication plan;
- > Identify high-risk locations and propose mitigation of the risk;
- > Emergency procedures in case of an incident;
- > Post-incident plan;

Drivers operating fatigue-regulated vehicles will have to comply with additional regulations and keep Work Diary as a detailed record of travel and stop times. Fatigue-regulated vehicles are:

- > motor vehicle with a Gross Vehicle Mass (GVM) of more than 12t;
- > combination with a GVM of more than 12t;
- > fatigue-regulated bus (GVM greater than 4.5t and built or fitted to carry more than 12 adults including the driver).

Motorhomes and vehicles operating primarily off road as machinery are excluded from this classification.

Work Diary will contain details of work and rest times to ensure that the drivers are working within the set work hours in line with the Heavy Vehicle (Fatigue Management) National Regulation (NSW) (2013 SI 245a) and NHVL. The records of the Work Diary must be provided to the employer, an accredited operator or to another authorised record keeper. The records must be kept for minimum three (3) years in a readable format and be accessible to authorised personnel for inspection, if required.

1.2.7 APPROVED ROUTES

All heavy vehicles must enter the Finley BESS site from Canalla Road via the Riverina Highway only. No access to site is permitted via any other local roads.

The routes for vehicle access to and egress from the Finley BESS are listed below:

- > Construction related vehicles arriving from east via Riverina Highway should turn left on Canalla Road;
- > Construction related vehicles arriving from west via Riverina Highway should turn right on Canalla Road;
- > Heavy vehicles, including RAV and OSOM will access the site via Canalla Road crossover;
- > Light vehicles will access the site via Broockmanns Drive;
- > Construction related vehicles shall not use Broockmanns Drive to travel to Finley, with the exception of local workers using passenger vehicles for travel.

The Drivers must stick to the defined routes laid down unless advised otherwise in exceptional circumstances. Such exceptional circumstances may be:

- > Normal route blocked e.g., flooded;

- > A revised route agreed in writing.

Trucks and heavy vehicles must not use local residential streets.

1.2.8 PARKING

1.2.8.1 On-Site Parking

Parking for all vehicles entering the site will be provided within the confines of the site with no reliance on parking on the local road network. There will be sufficient area within the site during differing phases of construction to accommodate vehicle parking, including construction traffic deliveries and on-site manoeuvring as and when required.

Parking areas will be designed to cater to the parking capacity and will clearly delineate class of parking. Parking for passenger vehicles will be separated from the parking for heavy vehicles. Parking for full-time employees' passenger vehicles will be clearly separated from the parking for visitors.

Short-term parking area for heavy vehicles is available adjacent to the Construction Compound to accommodate heavy vehicle inspections and deliveries.

The Driver will park on site where instructed at the induction.

1.2.8.2 On-Road Parking

The Driver may need to park on occasion along the route either as a part of fatigue management or for another reason. The Driver should park only in park and/or rest areas along the route wherever possible. Avoid parking on or within one metre of the roadway. If this is not possible, make sure that you use portable warning signs.

The driver is to always park vehicle in a safe position. The Driver is to make sure their parked vehicle can be seen and that it is as far away from the moving traffic as possible. If in doubt leave your hazard lights on.

If the Driver is transporting dangerous goods, there are additional restrictions that affect their parking and driving practices. The Driver must be familiar with Australian Dangerous Goods Code or an equivalent document that may be in use at the time of planning the route.

Vehicles are not permitted to park on public roads abutting the development site. If the vehicle is within 1km of the development site it must park on site, unless it requires an emergency stop.

1.2.9 REVERSING

Parking on site will be arranged to avoid reversing whenever possible. If reversing cannot be avoided, use extreme caution. If the Driver needs to reverse, the Driver shall:

- > Get out of the vehicle and check the rear surrounding area;
- > Check clearances at sides, top and bottom;
- > Constantly monitor mirrors for pedestrians or other traffic when reversing.
- > If reversing passenger vehicle, engage the use a spotter if practicable.
- > Use a minimum of one (1) spotter if reversing heavy vehicle.

1.2.10 RAW MATERIALS AND EQUIPMENT HAULAGE

Drivers are responsible for ensuring that all tailgates are properly closed and that there is no excessive leakage of water, dust, mud or loose materials from the vehicle to the road surface.

All loads must be secured and covered.

Drivers are responsible for ensuring that all loads are properly covered and that there is no spillage or leakage of the load from the vehicle to the road surface.

Drivers of trucks hauling raw materials to and from the works will ensure adequate separation between vehicles.

No tailgating or formation of rolling convoys shall be permitted.

1.2.11 ON ROUTE EMERGENCY PROTOCOLS

In the event of a breakdown, crash or road failure, the Driver or other responsible person shall do the following:

- > Stop the vehicle as soon as practicable (if it was not stopped by the incident), as safe as practicable and park the vehicle in such manner not to further endanger themselves or other participants in traffic (ensure the vehicle is as visible as possible, but not obstructing the traffic as much as possible, consider overhanging components, sightlines, horizontal and vertical geometry etc.);
- > Contact appropriate emergency services (including Police), depending on the type of crash or incident;
- > Take photographic evidence, if possible, without further endangering yourself or other people.
- > If possible and relevant, obtain contact details of witnesses to the event.
- > Contact the project manager and/or the site manager to report the situation and ascertain if the incident will require changes in the planned project traffic flows.
- > If appropriate, contact the road controlling authority.
- > Follow all instructions from the emergency services, Police and the road controlling authority.

In the case of a crash (inclusive of single-vehicle crash), the vehicles involved should not be moved until instructed so by Police.

1.3 Other

1.3.1 ROAD TRAFFIC ACT AND ROAD RULES

The Driver is required to know and comply with all road rules pertaining to their vehicle (whether standard passenger car, utility or heavy transport vehicle). They must operate vehicle only with a current licence appropriate for the class of the vehicle and with relevant permits (if applicable).

1.3.2 CHAIN OF RESPONSIBILITY

Chain of responsibility (COR) recognises the on-road effects of actions, inactions and demands of offroad parties in the transport and supply chain and provides for their accountability. COR laws aim to ensure that any off-road party in a position to control, influence or encourage particular on-road behaviour is identified and held appropriately accountable - keeping our drivers and community safe and making sure our transport networks remain productive.

This requirement means that all parties in transportation chain have a duty to ensure the safety of their transport activities, so far as is reasonably practicable. Responsible parties in the chain include: employers, prime contractors, operators, schedulers, consignors, consignees, packers, loading managers, loaders, and unloaders.

In addition, the executive or senior responsible officers of each party in the chain must exercise 'due diligence' to ensure the safety of their business's transport activities. The law will require officers to:

- > keep up-to-date with the safe conduct of transport activities in their business
- > fully understand the hazards and risks associated with their transport activities and how these are being managed
- > provide appropriate resources—including people, systems and equipment—to manage their safety hazards and risks effectively.

As a part of COR, the Driver is obligated to report and traffic management issues to the site coordinator and their supervisor.

1.3.3 DRIVING LICENCE

The Driver must hold a current and valid driving licence for the class of vehicle that they operate. Additionally, they must always carry their current driver's licence with them while on duty. If their licence is cancelled or suspended, they must inform their supervisor immediately.

Drivers of specialised vehicles must be appropriately trained and hold relevant current certifications.

1.3.4 VEHICLE MINIMUM MAINTENANCE AND OPERATING CONDITION

All vehicles must be maintained and operated in accordance with the vehicle manufacturers recommended standards (refer to vehicle manufacturer's handbook). The policy for maintenance of vehicles should further include, but not be limited to:

- > All vehicles will comply with the relevant state and federal legislation in relation to roadworthiness, modifications and approved combinations of vehicles;
- > Vehicles will be serviced only by qualified personnel;
- > Tyre pressure and tread depth should be checked regularly by specified personnel;
- > Safety belts will be checked for fading, fraying, cuts and flexibility
- > Regular rust checks on the main structural parts of any vehicle. If found, it should be repaired immediately.
- > Regular exhaust system checks;
- > Regular checks for special equipment: all vehicles should be fitted with a fire extinguisher, a first aid kit, a torch, a reflective vest and an emergency triangle.
- > Regular checks to satisfy other vehicle or driving task related requirements.

1.3.5 ENVIRONMENT

The Applicant for the Finley BESS is committed to protecting the environment and preventing air, water, noxious weeds and noise pollution. As the operator of your vehicle, you are subject to environmental regulations relating to vehicle emission and product spill. You must understand and appreciate the seriousness of polluting the environment, damaging farming land by carrying contaminated soil and the consequences of this. If you are careless or neglect your responsibilities, you can cause personal injury, loss of life, property damage, substantial fines, and adverse publicity for the project.

1.3.6 NOISE CONTROL

Using engine brakes can be extremely noisy. If possible, you should not use engine brakes near residences and built up areas. All vehicles must be fitted with audible reversing alarms. These are essential for the safety of all personnel. Reversing alarms are however the source of potential noise complaints from neighbouring residents

so all drivers should be aware of this and try to minimise reversing when possible. Generating excessive noise is governed by legislation and is an offence.

1.4 Times of Operation

This Driver Code of Conduct is applicable 24 hours per day, 7 days per week.

The Finley BESS operating hours are:

- > 7am-6pm Monday to Friday
- > 8am-1pm Saturday
- > At no time on Sundays or NSW Public Holidays unless approved.

1.5 Complaints, Resolutions and Disciplinary Action

Drivers should be aware that a complaints telephone number is available to the public to lodge complaints against any driver contravening this Code of Conduct. All complaints will be logged and investigated and, where appropriate, disciplinary action will be taken. The traffic and parking related complaints can be lodged in following manner:

- > Lodging a complain via electronic form available on [TBC];
- > Calling the complaint's line [TBC];
- > In person, on site, by filling out a form.

The site supervisor and/or dedicated WHS officer will collect, review and address the complaints.

1.5.1 PENALTIES AND DISCIPLINARY ACTION

Failure to comply with this Driver Code of Conduct will lead to either the issue of a "warning notice" or "disciplinary action" if the offender is directly employed by the project or EPC contractor.

If the offending party represents another company, then "disciplinary action" may be treated as suspension or cancellation of a service contract or arrangement with that company. A warning notice may be issued for several reasons, which may include, but not limited to:

- > Driving at excessive speed;
- > Use roads contrary to that described in the approved transport routes;
- > Abuse other road users or customers;
- > Do not carry out instructions as advised;
- > Do not report incidents/accidents;
- > Examples of behaviour that may result in disciplinary action are if you:
 - > Consume or are under the influence of alcohol or drugs whilst on duty;
 - > Fight or commit acts of violence towards any person whatsoever, whether directly employed on the project or otherwise;
 - > Are charged and found guilty of a serious offence causing an accident.
 - > Have received multiple warning notices for breaches of this Code of Conduct, or any other site rules or policies.

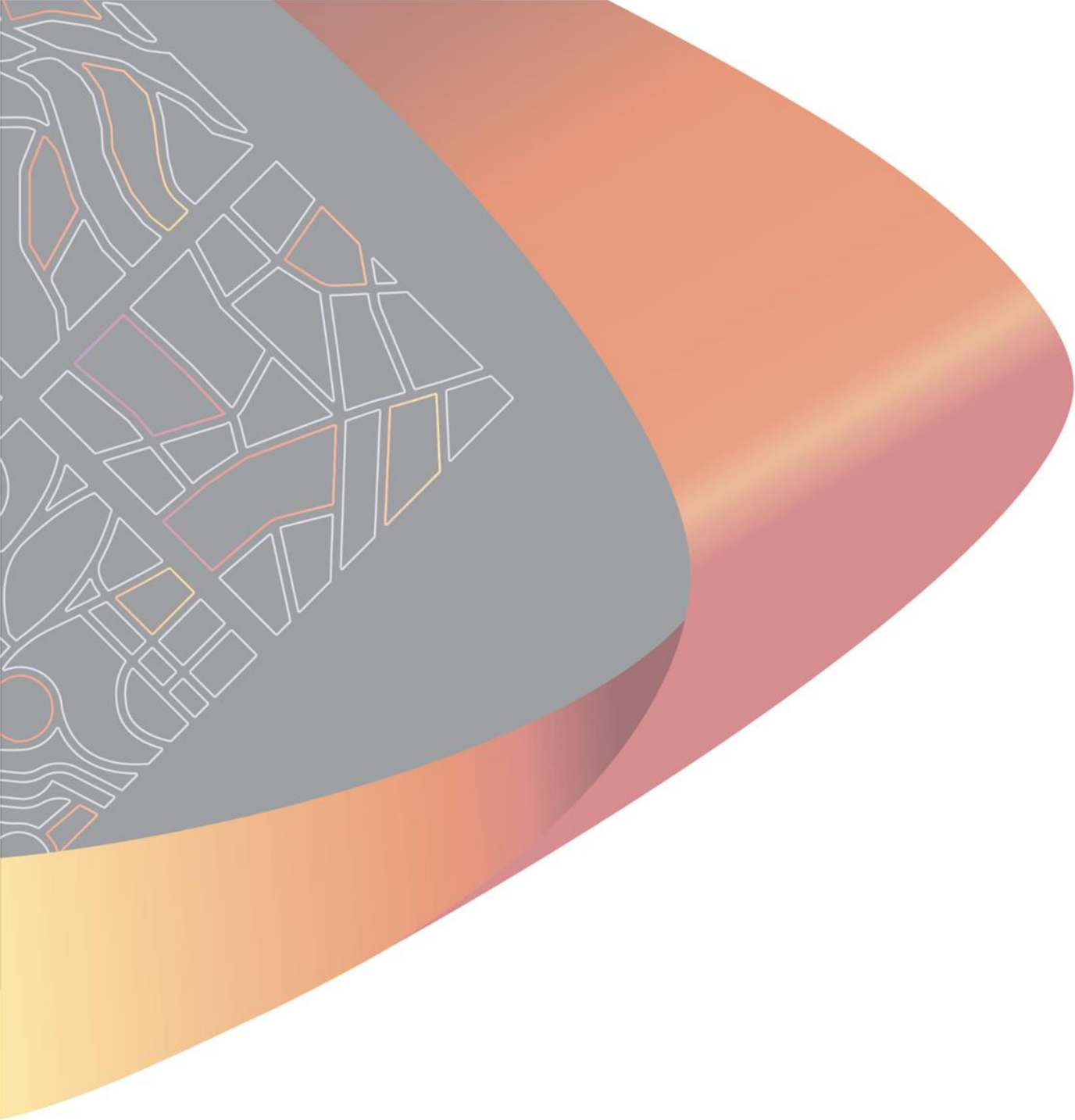

יש

