

Dangerous Goods Compliance Report

Glendenning Road Data Centre

Prepared for: LCI Consultants

Document no: GRDC86-XX-XX-RP-C-0004 – DG COMPLIANCE REPORT

Revision no: F



Disclaimer

This Report has been prepared in accordance with the scope of services described in the agreement between ACOR Consultants and the Client. The Report relies upon data, surveys, measurements and results based on instructions from, and in consultation with, the Client. Except as otherwise stated, ACOR Consultants has not attempted to verify the accuracy or completeness of any information provided by the Client. If the information is subsequently determined to be false, inaccurate or incomplete then it is possible that changes may be required to the Report. Changes in circumstances or facts, the passage of time, manifestation of latent conditions or impacts of future events may also impact on the accuracy, completeness or currency of the information or material set out in this Report. This Report has been prepared solely for use by the Client, ACOR Consultants Pty Ltd and its related body corporates accepts no responsibility for its use by any third parties without the specific authorisation of ACOR Consultants. ACOR Consultants reserves the right to alter, amend, discontinue, vary or otherwise change any information, material or service at any time without subsequent notification. All access to, or use of, the information or material is at the user's risk and ACOR Consultants Pty Ltd and its related body corporates accepts no responsibility for the results of any actions taken on the basis of information or material provided, nor for its accuracy, completeness or currency. For the reasons outlined above, however, no other warranty or guarantee, whether expressed or implied, is made as to the data, observations and findings expressed in this Report, to the extent permitted by law.

Revisions

Revision	Description	Date	Prepared by	Approved by
A	SSDA Issue	08 November 2024	Junelle Llorente	Matthew Buttarelli
B	SSDA Issue	14 November 2024	Daniel Lay	Matthew Buttarelli
C	SSDA Update	20 November 2024	Angie Zheng	Matthew Buttarelli
D	Issued for Public Exhibition – SSDA 73761707'	04 March 2025	Angie Zheng	Matthew Buttarelli
E	Updated Fuel Capacities	27 October 2025	Aleksandar Bajagic	Scott Tamasauskas
F	Updated New and Spent Battery Storage Capacities.	12 November 2025	Aleksandar Bajagic	Scott Tamasauskas

Review Panel

Division/ office	Name
ACOR Consultants	Matthew Buttarelli

COPYRIGHT

This document, including the concepts and information contained within it, are the property of ACOR Consultants Pty Ltd or any of its related or associated entities. Use or copying of this document in whole or in part without the written permission of ACOR Consultants Pty Ltd constitutes an infringement of copyright. No part of this document may be copied, reproduced, adapted, transmitted or stored in a retrieval system in any form or by any means without written permission or unless otherwise permitted under the Copyright Act 1968. Removal or modification of any copyright or other proprietary protection from this document will be a breach of copyright.

© ACOR Consultants Pty Limited

All intellectual property and copyright reserved.

Table of Contents

1	Introduction	8
1.1	Purpose of Report	8
1.2	Existing Site	8
1.3	Proposed Development	10
2	Objective	11
3	Scope	11
4	Basis of Assessment	12
5	Methodology	12
6	System Description	14
7	Regulation Quantities of Dangerous Goods	16
7.1	Placard and Manifest Quantities	16
7.2	Major Hazard Facility	16
8	Compliance Assessment	17
8.1	Diesel Storage	17
8.2	Tanker Offloading Area	21
8.3	Pumping Equipment	21
8.4	Spillage Containment	22
8.5	Separation Distances	22
8.6	Placards	23
8.7	Fire Protection	24
8.8	Emergency Response Plan	25
8.9	Safety Information	25
8.10	Lithium-ion Battery Rooms	25
9	Conclusion	28

Appendices

Appendix A	Safety Data Sheets	29
A.1	Diesel SDS	30
A.2	Battery Cabinet Material SDS	31

List of Figures

Figure 1.	Aerial Map of Subject Site (Source: NearMap, 2024)	9
Figure 2.	Site Context and Zoning (Source: Blacktown Local Environmental Plan, 2024)	9
Figure 3	Preferred LIB-ESS locations as per Data Sheet 5-33	27

List of Tables

Table 1 Acronyms	5
Table 2 Definition List.....	6
Table 3 Glendenning Road Data Centre Diesel Storage Distribution	11
Table 4 Dangerous Goods Storage Locations and Quantities based on supplied information	11
Table 5 UPS Battery System Storage and Operation Conditions	14
Table 6 List of Lithium-Ion Storage in Cabinets	14
Table 7 List of Lithium-ion Storage in Server Racks.....	15
Table 8 List of Spent and New Lithium-ion Storage	15
Table 9 Placarding and Manifest Quantity Limits as per WHS Regulations (2017).....	16
Table 10 Recommended Spill Containment Provisions	22
Table 11 Separation Distances as per AS1940:2017	22
Table 12 Placarding requirements as per AS1940:2017	23
Table 13 Required Fire Protection Equipment around the proposed facility according to AS1940:2017	24

Acronyms

Table 1 Acronyms

Acronym	Description
ACOR	ACOR Consultants Pty Ltd
ADG	Australian Dangerous Goods
ADG Code	Australian Code for the Transport of Dangerous Goods by Road & Rail
ALARP	As low as reasonably practicable
AS	Australian standard
AS/NZS	Australian/ New Zealand standard
DG	Dangerous Goods
DPIE	Department of Planning and Environment
EPA	Environment Protection Agency
ERP	Emergency Response Plan
LIB-ESS	Lithium-Ion Battery Energy Storage System
MHF	Major Hazard Facility
n/a	Not applicable
PG	Packing Group
PPE	Personal Protective Equipment
SDS	Safety Data Sheet
SEARs	Secretary's Environmental Assessment Requirements
SSD	State Significant Development
SSDA	State Significant Development Application
WHS	Workplace Health and Safety

Definitions

Table 2 Definition List

Terms	Definition
Category 3 tank	Rectangular tanks and tanks with unconventional shapes, intended principally for industrial use above-ground as either head tanks or storage tanks.
Category 4 tank	Horizontal cylindrical tanks of up to 150 m ³ capacity, for underground or above-ground use, intended principally for industrial or service station use.
Combustible liquid	<p>Any liquid, other than a flammable liquid, that has a flash point, and has a fire point that is less than its boiling point. For the purpose of this Standard, combustible liquids are divided into two classes as follows:</p> <p>Class C1 - A combustible liquid that has a closed cup flash point of greater than 60°C and no greater than 93°C. (dangerous goods for storage)</p> <p>Class C2 - A combustible liquid that -</p> <ul style="list-style-type: none"> has a flash point of greater 93°C; or has been excluded from being a flammable liquid by any of the criteria for sustaining combustion. (non-dangerous goods)
Ignition source	A source of energy sufficient to ignite a flammable atmosphere. Examples of ignition sources include naked flames, exposed incandescent material, electrical welding arcs, mechanical sparks, electrical discharge due to static electricity.
On-site protected place	A building where people are employed within the property boundary, including offices, warehouses, manufacturing or processing areas, amenities, and other dangerous goods stores where quantities exceed minor storage.
Public place	Any place other than private property, open to the public, which the public has a right to use, and which includes a public road
Reasonably practicable	<p>That which is, or was at a particular time, reasonably able to be done to ensure health and safety, taking into account and weighing up all relevant matters including:</p> <ul style="list-style-type: none"> (a) the likelihood of the hazard or the risk concerned occurring. (b) the degree of harm that might result from the hazard or the risk. (c) what the person concerned knows, or ought reasonably to know, about the hazard or risk, and ways of eliminating or minimising the risk. (d) the availability and suitability of ways to eliminate or minimise the risk. (e) after assessing the extent of the risk and the available ways of eliminating or minimising the risk, the cost associated with available ways of eliminating or minimising the risk, including whether the cost is grossly disproportionate to the risk.
Separation	Keep substances physically apart by distance

Criteria

This review and assessment were carried out based on the following criteria:

1. Legislation:

- Work Health and Safety (WHS) Act 2011;
- Work Health and Safety Regulation (2017);
- Australian Code for the Transport of Dangerous Goods by Road & Rail (Edition 7.9, 2024); and
- Code of Practice (CoP) Managing risks and hazardous chemicals in the workplace (May 2018).

2. Australian standards:

- AS 1940:2017: The storage and handling of flammable and combustible liquids;
- AS/NZS 4681:2000: The storage and handling of Class 9 (Miscellaneous) dangerous goods articles;
- AS 1692:2006: Steel tanks for flammable and combustible liquids;
- AS 4897:2008: The design, installation and operation of underground petroleum storage systems;
- AS ISO 31000:2018: Risk Management – Guidelines;
- FM Global Property Loss Prevention Data Sheet 5-32: Data Centres and Related Facilities; and
- AS IEC 62619:2023 – Secondary cells and batteries containing alkaline or other non-acid electrolytes — Safety requirements for secondary lithium cells and batteries, for use in industrial applications.

Limitations

ACOR has assessed this project based on the information provided by LCI Consultants (LCI) and the end client in relation to the storage quantities, locations, and design layout. It remains the responsibility of LCI and the end client to ensure that the installation meets the requirements and implement the controls as required by the relevant legislation.

Notes:

- This report and findings are not a substitute for full compliance with Australian standards and Codes of Practice. LCI shall ensure that they maintain their duty of care and consult the relevant legislation and guidelines.
- All information obtained is provided by relevant parties for verification and acceptance prior to being published.

Should the storage conditions or volumes change, the contents and findings in this report shall be reviewed, and the risks associated with any change assessed and controlled.

1 Introduction

1.1 Purpose of Report

LCI Consultants has engaged ACOR Consultants Pty Ltd (ACOR) to undertake a Dangerous Goods compliance review of the proposed diesel storage system for the Glendenning Road Data Centre and assist them with dangerous goods safety and compliance with Regulations.

Dangerous goods are substances that may pose an immediate hazard to people, property and/or the environment. They may be flammable, combustible, oxidising, water-reactive, toxic or corrosive. It is important that dangerous goods are appropriately identified and stored correctly.

This report outlines the general storage requirements for C1 combustible liquids and the UPS lithium-ion battery room. It provides design recommendations to ensure compliant and safe storage and handling at the Glendenning Road Data Centre facility.

1.2 Existing Site

The subject site is located at 2 Glendenning Road, Glendenning and is legally described as Lot 2 DP 1137162. It is zoned E4 General Industrial under the *Blacktown Local Environmental Plan 2015*.

The subject site comprises a total area of 10.44ha and exhibits a primary frontage to Glendenning Road at the western boundary for approximately 295m. A secondary frontage to Woodstock Avenue is located along the southern boundary, for a length of approximately 335m.

The subject site comprises three (3) existing warehouse buildings that undertake various operations, including storage and logistics and a transport vehicle centre. The buildings are positioned toward the Glendenning Road frontage and cover approximately one half of the subject site. The remainder of the subject site to the rear is vacant and contains a mix of grass, native vegetation and sporadic trees. A patch of mature native vegetation exists along the southern boundary, which is identified as outstanding biodiversity value. An established landscaping strip is located along the Glendenning Road frontage, providing some screening of the existing buildings.

Vehicle access is obtained via four (4) vehicles crossings off Glendenning Road, which provide separate access for the two (2) large tenants. Vehicle access is also provided off Woodstock Avenue for the southern tenant.

The subject site is traversed by overhead 132kV transmission lines and towers, managed by Endeavour Energy. A drainage reserve also exists directly north of the subject site, which is managed by Blacktown City Council.

The subject site is surrounded by industrial land to the north, west and south (refer to the site context in **Figure 2**). Directly adjoining the subject site to the east is the Nurragingy Reserve, which falls under the jurisdiction of the Western Parklands. The Eastern Creek is located within the reserve and runs along the eastern boundary of the subject site. The closest residential area is located approximately 400m to the west of the subject site on the opposite side of the Westlink M7 Motorway.

The subject site is depicted in **Figure 1**.



Figure 1. Aerial Map of Subject Site (Source: NearMap, 2024)

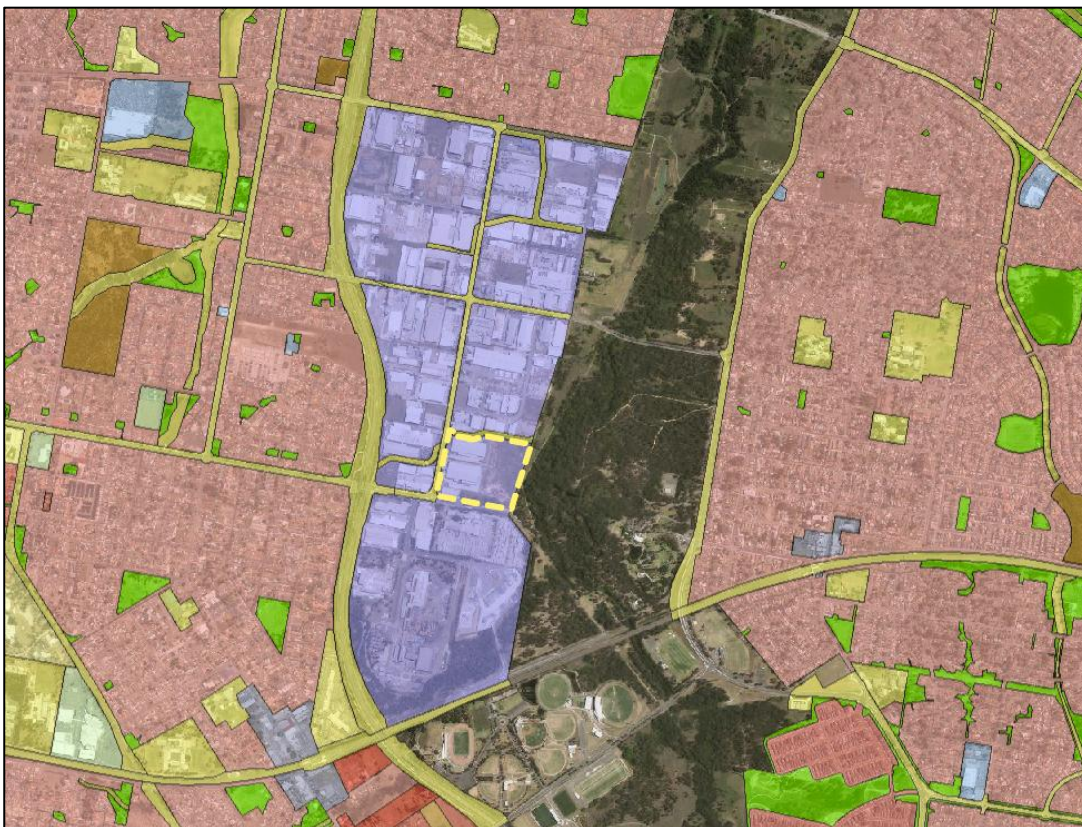

Figure 2. Site Context and Zoning (Source: Blacktown Local Environmental Plan, 2024)

1.3 Proposed Development

The proposal involves the staged construction and operation of a data centre development, comprising:

- Site preparation and establishment works including:
 - Bulk earthworks to create proposed site levels;
 - In-ground building services and utility work;
 - Clearance of trees and vegetation within the proposed development extent;
- Construction and operation of three data centre buildings, known as DC01, DC02 and DC03, comprising:
 - A total Gross Floor Area (GFA) of 50,233m² (DC01 – 19,985m², DC02 – 10,263m² and DC03 – 19,985m²);
 - A maximum building height of 45.3m, including five storeys for each building;
 - Three internal substations;
 - A total IT capacity of approximately 193.6MW (DC01 – 79.2MW, DC02 – 35.2MW and DC03 – 79.2MW);
- Total diesel fuel storage of 2,338,430L within underground bulk fuel storage tanks, generator day tanks, return fuel tanks and diesel fire pump tanks;
- 97 back-up generators across the full development;
- External plant and equipment (including water tanks and pump rooms);
- Installation of evaporative cooling units;
- Three vehicle crossovers to Glendenning Road and internal access roads;
- Security fencing surrounding the development, including a controlled entry and exit point;
- 165 on-site car parking spaces (including 6 accessible parking spaces and 12 Electric Vehicle (EV) parking spaces);
- Landscaping across the subject site;
- Hours of operation being on a 24 hours per day, seven days per week basis.

The proposed works would be constructed in three stages, as follows:

- **Stage 1:** The first stage would include the construction of DC01, located at the rear of the subject site. The three existing site buildings would be demolished.
- **Stage 2:** The second stage would involve the construction of DC02.
- **Stage 3:** The construction of DC03.

The proposed data centre will include storage and handling of the following dangerous goods:

- Diesel (C1 Combustible Liquid); and
- Lithium-ion Batteries

The entire facility has a total of 2,338,430L of diesel fuel storage comprised of 2,210,000L of diesel in underground bulk tanks, 96,030L within the day tanks of the generator units, 30,000L capacity in return fuel break tanks, and 2,400L within diesel fire pump tanks. The distribution is shown in Table 3.

Table 3 Glendenning Road Data Centre Diesel Storage Distribution

Building	Bulk Storage	Generator Storage (Day Tanks)	Return Fuel Storage	Fire Pump Storage
DC01	110 kL x 8 tanks = 880,000 L	990L x 39 generators = 38,610 L	10kL x 1 tank = 10,000L	-
DC02	90 kL x 5 tanks = 450,000 L	990L x 19 generators = 18,810 L	10kL x 1 tank = 10,000L	-
DC03	110 kL x 8 tanks = 880,000 L	990L x 39 generators = 38,610 L	10kL x 1 tank = 10,000L	-
Facility	-	-	-	1.2kL x 2 tanks = 2,400L

2 Objective

The objective of this report is to undertake a DG compliance review of the proposed diesel fuel storage and lithium ion batteries located at the Glendenning Road Data Centre against the criteria, identifying any non-compliances, and provide controls and recommendations to comply with the regulatory requirement. This assessment demonstrates that the facility can be operated safely, in compliance with the relevant standards and regulations, and with acceptable risk to people, property and the environment. This Dangerous Goods Report was submitted as part of the SSDA submission to DPIE for this proposed development (SSD-73761707), and has been updated in this revision to reflect the new diesel fuel storage quantities. The diesel stored across the facility has changed from a total of 2,736,030L to 2,338,430L.

This review is the first step in the identification of hazards, and subsequent risks, arising from the storage and handling of dangerous goods at the Glendenning Road Data Centre. This assessment documents LCI Consultant's efforts to reduce risk to as low as reasonably practicable, in accordance with the legislative requirements.

3 Scope

The scope of this report is to provide design guidance for the diesel storage facility and associated lithium-ion batteries in relation to dangerous goods storage and handling. The identified locations for the dangerous goods that are present onsite have been listed in Table 4 and Table 6. Controls for identified hazards are reviewed, in conjunction with LCI and in line with the requirements of the Regulations and any applicable Codes of Practice. Compliance assessment is also provided in Section 8 to assist LCI with the design.

Table 4 Dangerous Goods Storage Locations and Quantities based on supplied information

Storage Area	Storage Type	Chemical	Class/ Division	Quantity	Unit Capacity	Total Capacity
DC01	Bulk storage tank (Underground)	Diesel	C1	8	110,000 L	880,000 L
	Generator Day Tank			39	990 L	38,610 L
	Return Fuel Break Tank			1	10,000 L	10,000 L
DC02	Bulk storage tank (Underground)	Diesel	C1	5	90,000 L	450,000 L
	Generator Day Tank			19	990 L	18,810 L

Storage Area	Storage Type	Chemical	Class/ Division	Quantity	Unit Capacity	Total Capacity
	Return Fuel Break Tank			1	10,000 L	10,000 L
DC03	Bulk storage tank (Underground)			8	110,000 L	880,000 L
	Generator Day Tank			39	990 L	38,610 L
	Return Fuel Break Tank			1	10,000 L	10,000 L
Facility	Fire Pump Tank			2	1,200 L	2,400 L
Total Storage Quantity						2,338,430 L

4 Basis of Assessment

- The proposed fuel system specified in this report is based on diesel fuel that has a flash point greater than 60°C but not greater than 93°C and a fire point less than its boiling point. This fuel is classified as C1 combustible liquid, in accordance with the definition given in AS1940:2017. Refer to Appendix A.1 for diesel fuel SDS. Should the proposed fuel storage contain any other product, where the product is classified as flammable liquid, the assessment outlined herein is no longer applicable.
- The fuel storage tank within the generator enclosure is referred to as 'belly tank' by the designer. It is considered as a Category 3 service tank as per AS1940:2017, based on the design, location and intended use specified by the designer.
- Due to the location of the day tank (i.e., within the generator enclosure), the separation distances are based on the generator enclosure as one complete unit.
- The generator enclosures are considered as on-site protected places due to their occupancy by relevant personnel during maintenance, which exposes them to risks associated with surrounding dangerous goods (i.e., other diesel generators). Separation distances have been assessed with this consideration.
- Based on the supplied tank information, the bulk storage tanks and day tanks are designed to:
 - Bulk storage tank: AS1940:2017, AS1692:2006 and AS4897:2008
 - Day tank: AS1940:2017 and AS1692:2006

5 Methodology

The methodology for the review was to evaluate the existing controls and identify any areas of concern or non-compliance with the Act, Regulations and Australian Standards. The following steps were undertaken:

- An assessment of proposed DG facilities for compliance with relevant standards and codes, with particular focus on risk control measures specified in the Regulations, including:
 - Spill or leak containment;
 - Segregation of dangerous goods;
 - Stability;
 - Protection from impact;
 - Transferring dangerous goods;

- Ignition sources in hazardous areas;
 - Control of hazardous atmosphere;
 - Design, build, maintenance and location of storage or handling systems;
 - Accepting delivery of packaged dangerous goods;
 - Containers for bulk dangerous goods;
 - Lighting;
 - Access and egress;
 - Security at a dangerous goods site;
 - Control of fire hazards;
 - Placards;
 - Emergency management planning; and
 - Manifest and Dangerous Goods Site Plan.
- Document and review the hazards associated with non-compliance or other hazards identified.
 - Provide recommendations to address non-compliances.

Note: All information obtained is provided to the client for verification and acceptance prior to being published.

6 System Description

The Glendenning Road Data Centre emergency power supply is comprised of 97 x 2,800 kW diesel generators, each with 990 L day tanks, and supported by 16 x 110 kL underground diesel bulk storage tanks and 5 x 90 kL underground diesel bulk storage tanks. Fuel is transferred from bulk storage to the day tanks via a duty/ standby pumping system located within an internal fuel pump room set at the ground level of each building.

Diesel is supplied via a fuel tanker that is to be parked within an offloading area adjacent to the underground bulk storage tank area within each building. The access roadway is designed to accommodate a fuel tanker and allow other vehicles to pass. Decanting (i.e., offloading) of fuel to bulk storage is facilitated by a duty/ standby pumping system with corresponding filtration units. Fuel piping is located within concrete trenches equipped with hydrocarbon leak detection and watertight openable cover all throughout.

Each of the 3 data centre buildings has an allowance for a 10 kL return fuel break tank, adding an additional 30 kL to the overall storage capacity.

Additionally, the facility has 2 diesel fire pump tanks for fire services on site, each 1.2 kL. The diesel storage capacities are outlined in Table 4.

As part of the emergency power supply, the facility is also equipped with UPS battery systems for IT lineup. Each battery system is comprised of one (1) battery cabinet with 17 x 2.04 kWh lithium-ion battery modules within and each building has a total of two (2) dedicated battery rooms located at the ground level. Refer to Appendix A.2 for the battery modules SDS. The storage and operation conditions of the battery system are as follows:

Table 5 UPS Battery System Storage and Operation Conditions

Operating Temperature (Recommended)	23 ± 5°C
Storage Temperature	0 ~ 40°C
Storage Humidity	< 90% RH (non-condensing)
Storage Period	< 6 months

In the event that the main power supply is lost, these batteries provide a time limited power supply to support each data centre building, whilst the generators come online to pick up the data centre load. The batteries remain connected to a circuit, charging continuously to be ready for deployment, if required. Hence, these batteries are considered to be 'in use' and not stored dangerous goods. General storage recommendations, however, are provided in Section 8.10. The quantity of lithium-ion batteries in cabinets is listed in Table 6. Additionally, the details of lithium-ion batteries stored in the server racks are shown in Table 7.

Table 6 List of Lithium-Ion Storage in Cabinets

Storage Area	Storage Area Reference	Chemical	Class/ Division ¹	Energy Capacity	Storage Capacity ²
DC01	Electrical Room 0.1	Lithium-ion	Non-DG	34.6 kWh	4,000 kg
	Electrical Room 0.4H			34.6 kWh	
DC02	Electrical Room 0.1			34.6 kWh	4,000 kg

¹ Lithium-ion batteries are present on site but those connected to circuits are not considered as dangerous goods since they are in use.

² Total storage capacity was confirmed by LCI and the Tenant on 12/11/2025.

Storage Area	Storage Area Reference	Chemical	Class/ Division ¹	Energy Capacity	Storage Capacity ²
	Electrical Room 0.4H			34.6 kWh	
DC03	Electrical Room 0.1			34.6 kWh	4,000 kg
	Electrical Room 0.4H			34.6 kWh	
Total Capacity				207.6 kWh	12,000 kg

Table 7 List of Lithium-ion Storage in Server Racks

Battery Type	Power Shelves per Rack	Rating (kW)	Output Voltage (V)	Total Battery Capacity (kW)
WMW Samsung	2	2.131	49	4.262
WMW Panasonic	2	2.9	50.4	5.8
RP Panasonic	2	2.7	12	5.4
RP Flextronic	2	2.72	50.4	5.44
RP Lite-on	2	2.557	49	5.114

Separate to the batteries that are connected to the circuit and in use, the facilities store new and spent batteries for the server systems within two rooms within each building. Since both new and spent batteries are not in use, they are both considered dangerous goods storage. Compliance requirements for these battery storages can be found in Section 8.10

Table 8 List of Spent and New Lithium-ion Storage

Storage Area	Storage Area Reference	Class/ Division	Package size and type ³	Maximum Quantity (kg) ⁴
DC01	New Batteries Store	Class 9 (UN3480)	10 kg per battery	4,000
DC02	New Batteries Store		10 kg per battery	4,000
DC03	New Batteries Store		10 kg per battery	4,000

³ Information based on battery storage provided by LCI and the Tenant on 12/11/2025.

⁴ A maximum quantity has been nominated by the Tenant and confirmed by LCI on based on 12/11/2025.

Storage Area	Storage Area Reference	Class/ Division	Package size and type ³	Maximum Quantity (kg) ⁴
Facility (DC01, DC02 & DC03)	Spent Battery Stores		10 kg per battery	4,990
Total Capacity				16,990 kg

From the information provided by the tenant and LCI by email on 12/11/2025, the entire facility shall store 4,990 kg or less of spent batteries with the maximum 4,990 kg able to be stored in any one of the data centres or spread across the three.

The spent batteries are to be disposed of as soon as reasonably practical to ensure the 4,990 kg capacity is not breached. Therefore, the Environmental Protection License (EPL) threshold is not expected to be exceeded for the lithium-ion waste storage.

7 Regulation Quantities of Dangerous Goods

Table 9 Placarding and Manifest Quantity Limits as per WHS Regulations (2017)

Description of Dangerous Goods	Packing Group	Placarding Quantity	Manifest Quantity	Client Quantity
C1 Combustible liquids	N/A	10,000 L	100,000 L	2,338,430 L

Note: Lithium-ion batteries are classified as Class 9 dangerous goods under the ADG Code. However, Class 9 is not recognised under the WHS regulations and Schedule 11 Placard and Manifest Quantities. Hence, the lithium-ion batteries both in use and not in use storage are exempt from the dangerous goods regulations for the purposes of placarding and manifest notification.

7.1 Placard and Manifest Quantities

The aggregate diesel tank storage exceeds manifest and placarding quantities as per Table 9. As a result, SafeWork NSW must be provided with a written notice, which includes the manifest prepared under regulation 347 together with an emergency plan as per regulation 361. In general, the facility must comply with the requirements of the WHS Regulations and SafeWork NSW.

7.2 Major Hazard Facility

The WHS Regulations state that the operator of the facility shall notify the regulator of Schedule 15 chemicals that are present or likely to be present at the facility.

The proposed Glendenning Road Data Centre stores and handled combustible liquid (diesel), which is not listed in Schedule 15. Hence, MHF requirements do not apply to the proposed facility.

8 Compliance Assessment

8.1 Diesel Storage

8.1.1 Bulk Storage Tanks

The proposed bulk diesel storage is underground double-walled fibreglass buried tanks designed and manufactured to AS1940:2017, AS4897:2008 and AS1692:2006.

According to AS 4897:2008 the site is classified as a Class C site. This is based on the permeability of the subsurface which is considered to be 'low' according to the desktop review done on the *Final Geotechnical Assessment Report (Document no. P2310014JR01V03)* prepared by Martens, and from relevant site classification. As such equipment level 3 is suitable for use in the site.

In addition, the proposed storage is to comply with the following key requirements:

- The underground tank shall be double-walled.
- The tank, its anchorage and associated piping shall be protected from corrosion by either:
 - Protecting coating or wrapping;
 - Cathodic protection as per AS2832.1 :2015 and AS2832.2:2003); or
 - Use of corrosion-resistant construction materials (e.g., FRP).
- The underground tanks' separation from the site boundary is to be at least 2m.
- Any underground tank shall be protected from corrosion by wrapping, cathodic protection or construction materials.
- A tank shall be double walled or provided with equivalent integrity wherein there is risk of leakage into a building.
- The underground tanks shall be separated from each other by at least 150mm and shall be installed as per the manufacturer's instructions.
 - As per the manufacturer's instructions, if more than one tank is to be installed in the same excavation hole, there must be at least 2 x Deadman between the tanks, which is equivalent to ~300mm (minimum). Hence, the manufacturer's installation requirements exceed that stipulated by AS4897:2008.
- The underground tanks are to be located such that the loads of adjacent buildings are not transmitted to the tanks.
 - Particularly relevant to the proposed tanks in DC02.
- In addition to the high-level alarm (LAH), a physically and electrically independent high-high level alarm (LAHH) shall be provided.
- Leak monitoring shall be provided by a means of a system that
 - Shall be rated to 0.76 L/h (with probability of detection of at least 95% and false detection of 0.05 or less); and
 - Can detect a leak from any portion of the tank or product piping.
- Any or a combination of the following means shall be applied:
 - Automatic tank gauging;
 - Statistical inventory analysis;

- Interstitial monitoring;
- Line leak detection for pressure piping; and
- Ground water monitoring.
- Tank pit observation well shall be installed in each individual tank excavation with a minimum of two (2) for excavations with two or more tanks. It shall be:
 - Installed such that it terminates at least 150mm below the bottom of the tank and within 150mm of the low point of the excavation;
 - Design and installed to enable detection of product vapour or free-phase product in the excavation.
 - Clearly marked, secured from tampering and sealed from the ground surface to the top of the filter pack.

8.1.2 Day Tanks

The day tanks shall comply with the requirements of Service tanks as per Section 5.14 of AS1940:2017 and the following storage and handling requirements as identified for tanks located indoors:

- The day tanks are classified as Category 3 tanks, and therefore are to also comply with Section 5.4.4 of AS1940 which states that the vent discharge for combustible liquids shall be located laterally by at least 2m from any opening into a building and at least 4m above ground level.
- Since the day tanks are located at a higher elevation than the bulk storage tanks, overflow piping to the bulk storage tanks shall be provided. The overflow pipe shall be sufficiently sized to return the full capacity of the pump to the return fuel tanks and then pump back to the bulk storage tank without spillage.
- Emergency shut-off provision shall be provided from the storage tank and service tank to the generator.
- An emergency shut-off device shall be provided and easily accessible on each pump.
- Provision shall be made to shut off the flow of liquid quickly in an emergency from the storage tank and service tank and to a tank vehicle fill point.
- The 990L day tanks shall be:
 - Not interconnected;
 - Provided with means to contain the spread of any small leak or spill; and
 - Separate from each other, and any another tank, by at least 3m.
- The day tanks are to be fitted with a high-level alarm set at a maximum of 97% and normal fill level set a maximum of 95% of the tanks' capacity.
 - This requirement is met by the proposed design as documented in Drawing number ASK015 Issue 8 dated 10th July 2024.
- Lighting within the room shall be provided during hours of operation, sufficient to enable a person to easily read all markings on signs, instruments and other necessary items. (Minimum value of 50 lx).

8.1.3 Return Fuel Tanks

Each data centre building will have 1 x 10 kL return fuel tank for overflow return fuel coming back from the day tanks. These tanks will also be underground and constructed in a similar manner to the bulk fuel storage tanks.

The proposed storage is to comply with the following key requirements:

- The underground tank shall be double-walled.
- The tank, its anchorage and associated piping shall be protected from corrosion by either:
 - Protecting coating or wrapping;
 - Cathodic protection as per AS2832.1 :2015 and AS2832.2:2003); or
 - Use of corrosion-resistant construction materials (e.g., FRP).
- The underground tanks' separation from the site boundary is to be at least 2m.
- Any underground tank shall be protected from corrosion by wrapping, cathodic protection or construction materials.
- A tank shall be double walled or provided with equivalent integrity wherein there is risk of leakage into a building.
- Underground tanks shall be separated from each other by at least 150mm and shall be installed as per the manufacturer's instructions.
- The underground tanks are to be located such that the loads of adjacent buildings are not transmitted to the tanks.
- Leak monitoring shall be provided by a means of a system that
 - Shall be rated to 0.76 L/h (with probability of detection of at least 95% and false detection of 0.05 or less); and
 - Can detect a leak from any portion of the tank or product piping.
- Any or a combination of the following means shall be applied:
 - Automatic tank gauging;
 - Statistical inventory analysis;
 - Interstitial monitoring;
 - Line leak detection for pressure piping; and
 - Ground water monitoring.
- Tank pit observation well shall be installed in each individual tank excavation with a minimum of two (2) for excavations with two or more tanks. It shall be:
 - Installed such that it terminates at least 150mm below the bottom of the tank and within 150mm of the low point of the excavation;
 - Design and installed to enable detection of product vapour or free-phase product in the excavation.
 - Clearly marked, secured from tampering and sealed from the ground surface to the top of the filter pack.
- The return system is to incorporate at least two independent overfill shut-off devices, arranged such that each will continue to function to prevent an overfill in the event of failure of the other device.

8.1.4 Diesel Fire Pump Tanks

The diesel fire pump tanks are located internally within the fire pump house which is a separate structure, outside of DC01 and DC02. The diesel fire pump tanks may be considered minor storage provided they comply with the following requirements of Section 2 of AS1940:2017 and the following storage and handling requirements:

- The fire pump house is considered minor storage if:

- 2,500 L of diesel or less is stored in an attached outhouse or shed to the data centre building separated by a partition having an FRL of 60/60/60; or
- 5,000 L of diesel or less are stored in a detached shed or outhouse separated by the data centre building by at least 1 m.
- The storage area is required to be adequately ventilated.
- Liquids shall not be allowed to reach ignition sources, stores of other chemicals, or combustible materials (e.g. timber and paper), or flow into drains or onto neighbouring land, or enter any creek, pond or waterway.
- A spill-response kit may consist of a readily identifiable, suitable container with a lid or cover containing absorbent materials, a PPE, and suitable equipment required for spill clean-up.
- Any tank that is intended for the storage of combustible liquids shall comply with AS 1692.
- Tanks shall be inspected and maintained regularly as per Section 9 of AS1940.
- An emergency shut-off device shall be provided and easily accessible on each pump.
- Provision shall be made to shut off the flow of liquid quickly in an emergency from the storage tank and to a tank vehicle fill point.
- The normal fill level is to not exceed 95% of the tank capacity (overflow level).
- The provision of a dipstick without an alarm is acceptable.
- Tanks shall not be arranged end-to-end.

8.1.5 Fuel Piping

The fuel piping shall comply with AS1940:2017, AS4041:2006 and AS4897:2008. The key requirements are as follows:

- The piping shall be suitable for the expected working pressures, temperatures and structural stresses and the material shall be compatible with diesel.
- The following considerations shall be applied:
 - Accessibility during operation, testing, maintenance, replacement or drainage;
 - Support and fixing;
 - Exposure to mechanical damage, particularly at the tanker offloading area;
 - Corrosion protection, particularly for piping located outdoors or underground;
 - Integration with any cathodic protection;
 - Pressure and thermal relief;
 - Expansion and contraction of piping with site conditions;
 - Drainage for any trench in which pipes are laid;
 - Protection for any buried piping from superimposed loads or ground settlement;
 - Electrical bonding and earthing as per AS/ NZS 1020:2023 and AS/ NZS IEC 60079.32.2:2022); and
 - Painting and marking of piping for identification of its contents as per AS1345:1995.

- Should any portion of the piping system be directly laid in the earth, it is to be located at least 300mm below ground level, suitably protected if the area is subject to vehicular traffic and protected from corrosion.
- Secondary containment for diesel piping shall be double-walled piping with interstitial space.
- A vent pipe shall not pass through building foundations but may be embedded in concrete that is part of other building construction.
- Joints in vents shall be of such quality as to prevent vapour leaking, and located so that any leaking that might occur, is prevented from accumulating inside or transferring into enclosed spaces.
- Where vent piping penetrates a fire-rated wall, it will be installed to maintain the fire resistance of the wall.

8.2 Tanker Offloading Area

The tanker offloading area is to be designed to AS1940:2017 and AS4897:2008 requirements. The key requirements are as follows:

- The fill point shall be protected from accidental damage.
- The fill point shall be clearly identified and shall comply with AS4977:2008.
- Static electricity shall be dissipated during tank vehicle filling in accordance with AS/NZS 1020 or IEC 60079-32-2 via provision of an earthing or bonding reel at the fill point.
- As per Section 4.3.5 of AS4987:2008, each fill point shall be dedicated to one tank only.
 - The proposed fuel system has two (2) fill points servicing nine (9) underground tanks. In order to meet the requirements of AS4897, each tank shall be provided with separate fill points.
 - If separate fill points cannot be implemented, a potential alternative solution to meet the intent and practical application of AS4897 is for the control system is to allow for tank selection during offloading such that no two (2) tanks receive fuel at the same time (i.e., each fill point allows receipt of fuel into one tank only). This is the intended approach of the project.
 - Where there is an alternative approach which deviates from the standard, a risk assessment is to be undertaken to demonstrate that the requirements and intent of the standard are met.
- Ensure the length of the fuel transfer hose shall be kept to a minimum ($\leq 6\text{m}$ is best practice).
- Sufficient lighting is to be provided for the road tanker unloading area to provide safe working conditions and clear visibility of all signs, level instrumentation and alarms.
- A tank vehicle shall be positioned at all times so that in an emergency it can be driven or towed straight out without recourse or reversing

8.3 Pumping Equipment

Fuel pumping equipment shall comply with AS1940:2017 Clause 6.4. Key requirements are as follows:

- Where the discharge downstream of the pump can be shutoff, provision shall be made to prevent or relieve potential excess pressure or thermal effects. This is to be achieved via provision of a hydraulic relief valve; and
- An emergency shut-off device shall be provided on each pump. This device shall be readily accessible and clearly labelled.

8.4 Spillage Containment

Provision shall be made to contain any leak or spillage and prevent contamination of the surrounding area and/or stormwater system. Therefore, the following requirements apply:

Table 10 Recommended Spill Containment Provisions

Tank/ Area	Spill Containment Provisions
Underground Bulk Storage Tanks	The tanks are double-walled and the interstitial gap is to be provided with interstitial dip or monitor to detect any leak from the primary tank. The tanks are designed to AS1940: 2017, AS 1692: 2006 and AS4897:2008.
Day Tanks	The day tanks are single-walled tanks that are equipped with a spill tray to contain small leaks as per Section 5.6.3.1 of AS1940:2017. A spill response kit shall be readily available within the generator room to prevent spills.
Return Fuel Break Tanks	The tanks are double-walled and the interstitial gap is to be provided with interstitial dip or monitor to detect any leak from the primary tank. The tanks are designed to AS1940:2017, AS 1692:2006 and AS4897:2008.
Diesel Fire Pump Tanks	The diesel fire pump tanks are subject to minor storage provisions. Precautions should be based on the quantity of the largest tank kept. A spill-response kit may consist of a readily identifiable, suitable container with a lid or cover containing absorbent materials, a PPE, and suitable equipment required for spill clean-up.
Tanker Offloading Area	Each fill/ decanting point shall be provided with a spill containment with a minimum volume of 15L (per fill point). Liquid level indication and information on the normal fill level of each tank shall be provided at the fill point (or at the control room if the decanting operation is monitored remotely). A spill response kit shall be positioned within 15m of the tank fill point.

8.5 Separation Distances

In accordance with AS1940:2017, the following minimum separation distances apply to the underground bulk storage tanks and generator day tanks:

Table 11 Separation Distances as per AS1940:2017

	Minimum distance required (m)	Actual distance (m) ⁵	Complies
Separation required from underground bulk storage tanks to			
Other underground tanks	150 (mm)	587(mm)	Yes
Adjacent properties/ property boundary	2	~10	Yes
Separation distance generator day tanks to			
Other day tanks/ generator enclosures	3	> 3	Yes

⁵ Compliance has been confirmed by LCI Consultants in their email dated 24th October 2025.

	Minimum distance required (m)	Actual distance (m) ⁵	Complies
On-site protected places (e.g., office buildings, workshops, amenities block on the same premises)	Unrestricted	8	Yes
Security fence	3	~26	Yes
Separation distance of tank vents to			
Opening into a building	2	2	Yes
Separation required from return fuel break tanks to			
Other underground tanks	150 (mm)	> 15	Yes
Adjacent properties/ property boundary	2	> 15	Yes
Separation required from diesel fire pump tanks to			
Other flammable and/or combustible liquid storage (larger than minor storage)	5	> 10	Yes
On-site protected places (e.g., office buildings, workshops, amenities block on the same premises)	Unrestricted	~20	Yes
Security fence	3	> 100	Yes

8.6 Placards

Any dangerous goods storage and handling site with more than a placard quantity of dangerous goods must:

- Ensure that an Outer warning placard is displayed at every entrance to site.
- The placard must display the word 'HAZCHEM' in red letters on a white or silver background.
- Be visible from the normal direction of approach to site.
- Be regularly reviewed and updated, as necessary.

Table 12 Placarding requirements as per AS1940:2017

Location	Placarding Required
At the entrance(s) to the Data Centre facility	HAZCHEM sign, black letters on a white background, at least 100 mm high A WARNING—RESTRICTED AREA, AUTHORIZED PERSONNEL ONLY sign A sign listing the emergency contact names, titles and phone numbers relevant to the installation. The name, address, and phone number of the occupier; and A layout diagram showing the location of fire protection facilities, the drainage system and the 'Emergency Stop' switches.
Tanker Offloading Area	A prominent sign on or near the dispenser shall be marked in letters at least 50 mm high as STOP ENGINE—NO SMOKING. Each fill point for storage tank shall be clearly identified.
Generator Day Tank	Markings to be displayed on the outside shell of the tanks which are not less than 150 mm in height Above ground tanks marked with the following:

Location	Placarding Required
	<ul style="list-style-type: none"> ▪ Tank identification number/letters; ▪ “COMBUSTIBLE LIQUID”; ▪ Safe fill level; and ▪ Total capacity. <p>At the entrances to the tank storage area:</p> <ul style="list-style-type: none"> ▪ “DANGER – RESTRICTED AREA, AUTHORISED PERSONNEL ONLY” placard; and ▪ “NO SMOKING, NO IGNITION SOURCES” placard.
Diesel Fire Pump Tank	<p>Markings to be displayed on the outside shell of the tanks which are not less than 150 mm in height</p> <p>Above ground tanks marked with the following:</p> <ul style="list-style-type: none"> ▪ Tank identification number/letters; ▪ “COMBUSTIBLE LIQUID”; ▪ Safe fill level; and ▪ Total capacity. <p>At the entrances to the tank storage area:</p> <ul style="list-style-type: none"> ▪ “DANGER – RESTRICTED AREA, AUTHORISED PERSONNEL ONLY” placard; and ▪ “NO SMOKING, NO IGNITION SOURCES” placard.

Where two or more points of access are adjacent to each other so that a single set of signs and notices are clearly readable from each point of access, duplicate signs and notices are not required.

Signs shall comply with AS1319:1994. Class labels shall conform to AS1216:2006 and be a minimum of 250 mm square. Other signs shall have lettering at least 50 mm high.

8.7 Fire Protection

As a minimum, the fire protection system is to meet the requirements of AS1940:2017 Section 11. The following fire protection equipment will be provided for the diesel system:

Table 13 Required Fire Protection Equipment around the proposed facility according to AS1940:2017

Location	Fire Protection Equipment
At the fill point	At least one powder-type portable extinguisher is to be provided within 10 m of a hose connection point or a manifold.
At the pump room	At least one powder-type extinguisher is to be provided between 3m and 10m from the pumps.
At the generator enclosure room (day tanks)	At least one powder-type portable extinguisher is to be provided within 10 m of each tank. 10L/s fire hydrant system designed and installed in accordance with AS2419.1.
At the fire pump tanks	At least one powder-type portable extinguisher is to be readily accessible adjacent to the storage area.

Note: Where the term ‘powder-type extinguisher’ is used it shall mean a portable powder-type fire extinguisher having a rating of at least 2A 60B(E) and 9 kg capacity. Where the term ‘foam extinguisher’ is used it shall mean a portable foam fire extinguisher having a rating of at least 2A 20B.

The fire detection, warning and alarm system within the facility shall comply with AS1940:2017, AS1670 and AS1603.5:1996. Its power supply shall be independent of the main electricity isolating switch for the area and shall be connected to a fire station nominated by Fire and Rescue NSW. Manual alarm call points shall be located at convenient and safe locations around the facility.

8.8 Emergency Response Plan

The Regulations require the operator of the facility to prepare and implement a written emergency plan for dealing with any dangerous event associated with the storage and handling of dangerous goods at the site. The operator is to ensure that the site emergency response plan/procedure meets the following requirements:

- Information on the size and complexity of the installation, its resources, and personnel.
- Consider any potential for the occurrence of fire, explosion, natural disaster, reaction, or release of dangerous goods.
- The operator of the site must ensure there is an emergency plan for the site and a copy of current plan is kept on the site; and
- Regularly reviewed and updated, as necessary.

Lithium-ion batteries room to be considered in the emergency management plan with respect to fire hazards.

8.9 Safety Information

Safety information, intended principally for emergency services, will be provided at a suitable location near the entrance to the facility and indicate the location of the following:

- the emergency plan;
- the manifest;
- PPE and clean-up equipment; and
- utilities and their isolation points.

Such information will be available at the main site entrance, or at one entrance, if there is more than one access point.

8.10 Lithium-ion Battery Rooms

The following requirements apply to the proposed Battery Rooms in Glendenning Road Data Centre. In DC01, these are specific for the dedicated rooms within Electrical Room 0.1 and Electrical Room 0.4H.

Additionally, each building has two dedicated rooms for storing new and spent batteries. These storage areas are used exclusively for storage, with no charging activities taking place.

8.10.1 AS/NZS 4681:2000

During the transport and storage of lithium-ion batteries (new or used), the cells are regarded as Class 9 dangerous goods, and risks may be managed by implementing the relevant clause in AS/NZS 4681. The proposed battery systems in the Glendenning Road Data Centre are classified as Class 9 dangerous goods (UN3480).

Some lithium-ion batteries will be connected to the electrical circuit and therefore considered in use. Hence, AS/NZS 4681:2000 is not considered to be applicable for these batteries in the Glendenning Road Data Centre. Separately, the new and spent lithium-ion batteries being stored in each building and not connected, fall under the scope of this Standard. Therefore, the following minimum requirements are applicable:

- The two battery stores are considered 'rooms within a building' as per the store definition in AS/NZS 4681;
- Stores for storage of lithium batteries shall be separated from protected places and boundaries by at least 3m as per the standard, separation distances may be achieved by the use of screen walls;

- The maximum storage height of the batteries shall be marked within each room. This is nominally below the sprinkler system and shall be based on any fire protection advice for effective fire protection performance;
- The store construction shall be non combustible;
- Sufficient lighting shall be provided during the hours of operation, that includes safe working conditions, and clear visibility of all signs, labels, instruments and other necessary items;
- Adequate natural or mechanical ventilation shall be provided;
- Where mechanical ventilation is provided, it shall comply with AS 1668.2. It is understood that a ventilation system complying with AS 1668.2 has been provided;
- All access ways shall be maintained in a safe condition. Where racking is installed, their layout shall allow for clear passage of personnel;
- Storage areas shall be secure against unauthorised entry;
- The appropriate dangerous goods class labels, with sides of at least 250 mm;
- A warning sign to restrict unauthorized entry;
- Where applicable, a warning sign to prohibit smoking and other ignition sources, e.g. 'DANGER: NO SMOKING, NO IGNITION SOURCES';
- Where applicable, warning signs indicating the presence of elevated temperature liquids;
- Fire protection requirements shall be based on consultation with authorities and the standard (AS/NZS 4681).
 - AS/NZS 4681 requires as a minimum, fire protection as per BCA requirements and portable fire extinguishers.
 - Based on the fire safety study conducted and consultation with Fire and Rescue NSW (FRNSW), a fire sprinkler system will be installed for the proposed storage areas.
- Fire sprinkler systems shall be installed in accordance with AS 2118 and maintained in accordance with AS 1851.3;
- Stores of dangerous goods shall be adequately protected from adjacent potential fire exposures by the use of fire-rated radiation barriers. In accordance with FRNSW consultation, each room has been separated with 4hr fire walls which achieves this intent.

8.10.2 AS IEC 62619:2023

The following requirement will be implemented in Glendenning Road Data Centre for lithium-ion batteries connected to a circuit:

- Wiring and its installation will be sufficient to withstand the maximum anticipated voltage, current, temperature, altitude, and humidity requirements.
- The casing of a cell, module, battery pack and battery system will incorporate a pressure relief function that will preclude rupture or explosion.
- The design of the battery system will be such that abnormal temperature-rise conditions are prevented.
- Terminals will have clear polarity markings on the battery packs or the system's external surface.
- The cell manufacturer will provide information about the product's current, voltage and temperature limit.
- The battery system will be provided with a voltage control function to ensure the voltage of each cell does not exceed the upper limit charging voltage specified by the manufacturer.

8.10.3 FM Global Property Loss Prevention Data Sheet 5-32

FM Global Property Loss Prevention Data Sheet 5-32: Data Centres and Related Facilities applies to Glendenning Road Data Centre for lithium-ion batteries connected to a circuit. Consequently, the following datasheets are also applicable:

- 5-33: Lithium-Ion Battery Energy Storage Systems;
- 5-23: Design and Protection for Emergency and Standby Power Systems; and
- 5-28: DC Battery Systems.

The following key requirements must be considered:

- Penetrations and piping that passes through fire-rated floors and walls shall use FM approved or listed penetration seals with fire-resistance rating that is equivalent to the rating of the floor or wall. In general, it is to comply with Section 2.2.4 of Data Sheet 5-32.
- The proposed battery system stored in battery cabinets with 17 x 2.04 kWh batter modules within (as detailed in Table 6) shall comply with the requirements of Section 2.3.5.2.7 of Data Sheet 5-32 and therefore shall also comply with the requirements of Data Sheets 5-28 and 5-23.
- The proposed battery system stored in server racks (as detailed in Table 7) shall comply with Section 2.3.5.2.8 of Data Sheet 5-32.
- Should the proposed battery system stored within the server racks exceed 20 kWh (per server rack), it will be considered an Energy Storage System (ESS) which it is to then follow Data Sheet 5-33.

Location:

- The battery system within server racks exceeding 20 kWh (per server rack) must be located in accordance with Section 2.3.1 of Data Sheet 5-33 in a dedicated interior cutoff room with at least one exterior wall that is accessible for manual firefighting as shown in Figure 3. The cut-off room is to comply with Section 2.3.4 with a minimum 2-hour fire rated room with LIB-ESS installed with minimum separation distance as per Section 2.3.5 of Data Sheet 5-33 as follows:
 - 1.8m from the accessible face of the LIB-ESS rack to non-combustible materials; and
 - 2.7m from the accessible face of the LIB-ESS rack to combustible materials.

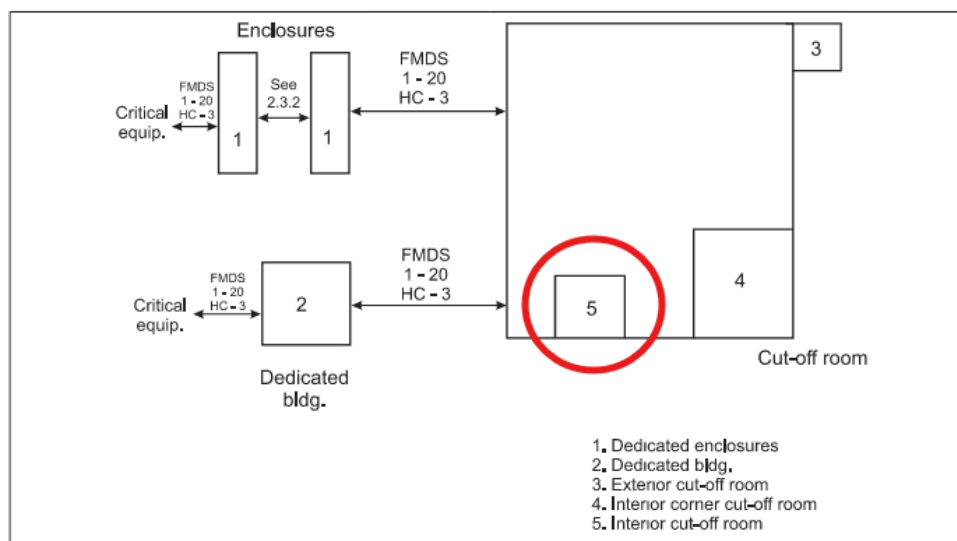

Figure 3 Preferred LIB-ESS locations as per Data Sheet 5-33

Protection:

- An automatic sprinkler protection with application density of 0.2gpm/ft² (8mm/min) is to be provided over the room area with an additional allowance of 250 gal/min (950 L/min) for hose streams. Additionally, the water supply is to be capable of providing sprinkler water and hose stream requirements for the duration of the fire event.
- A smoke detection system designed to Data Sheet 5-48 (Automatic Fire Detection) is to be provided within the battery room.

Human Element:

- An emergency response plan will be developed for the Glendenning Road Data Centre, in accordance with Section 2.7.2 of Data Sheet 5-32, and with local codes and relevant standards.
- A power isolation plan will be developed for the Glendenning Road Data Centre, in accordance with Section 2.7.2 of Data Sheet 5-32, and with local codes and relevant standards.
- The Glendenning Road Data Centre will have a security system including CCTV cameras.
- Card authorisation system and will be manned 24/7 by security personnel.

9 Conclusion

This report details the high-level compliance requirements for the diesel fuel system and lithium battery rooms associated with the Glendenning Road Data Centre in accordance with the regulations and to operate with acceptable risk to people, property, and the environment.

The dangerous goods stored at Glendenning Road Data Centre can be stored safely provided that all the design requirements of dangerous goods listed in this report are met and upheld during normal operations.

Appendix A Safety Data Sheets

A.1 Diesel SDS

A.2 Battery Cabinet Material SDS