

LEGEND

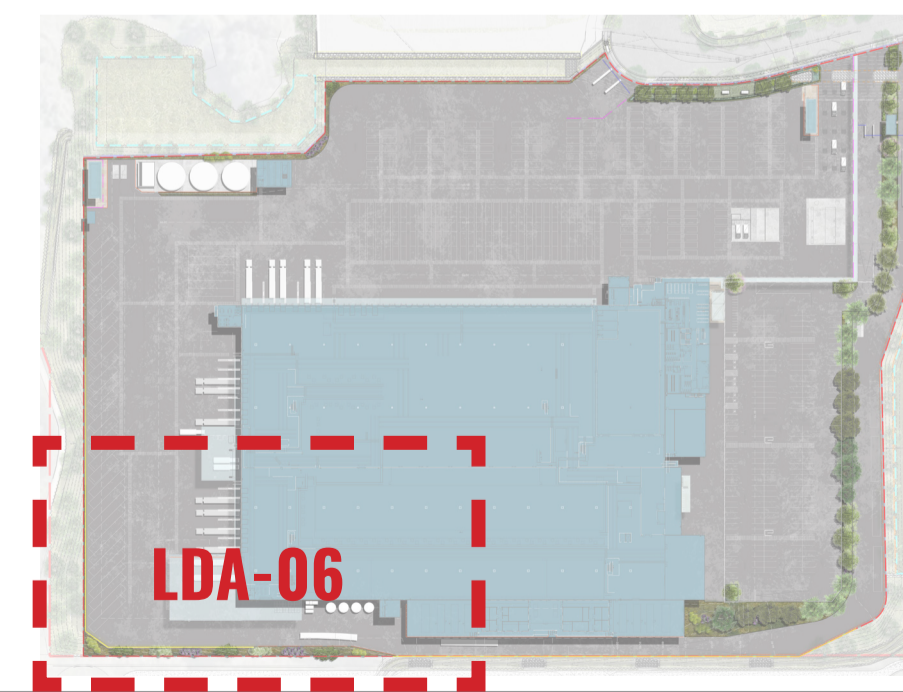
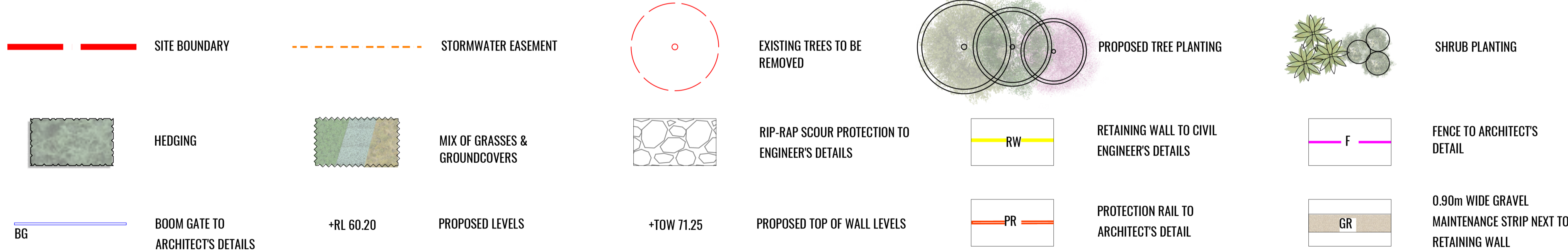

Drawing Title:
Landscape Detail Plan 5
 DWG No:

LDA-06

GEOSCAPES
 LANDSCAPE ARCHITECTS
 Suite 215, 284 Victoria Ave, Chatswood NSW 2067 Ph. (02) 9411 1485
 www.geoscapes.com.au
 ABN 84 620 205 781 ACN 620 205 781

Architect:
LEFFLER SIMES ARCHITECTS

Client:
Charter Hall

Scale:
 1:250 @ A1
 1:500 @ A3

Date:
 24.06.2020

Job Number:
 191129

North:

Project:
CUSTOMER FULFILLMENT CENTRE
 Horsley Drive Business Park - Stage 2, Wetherill Park, NSW 2164

Revision		FOR DEVELOPMENT APPLICATION			
Rev	Date	Description	Drawn	Checked	
K	18.06.20	FOR DA	SW	BG	
L	24.06.20	UPDATED FOR DA	SB	BG	

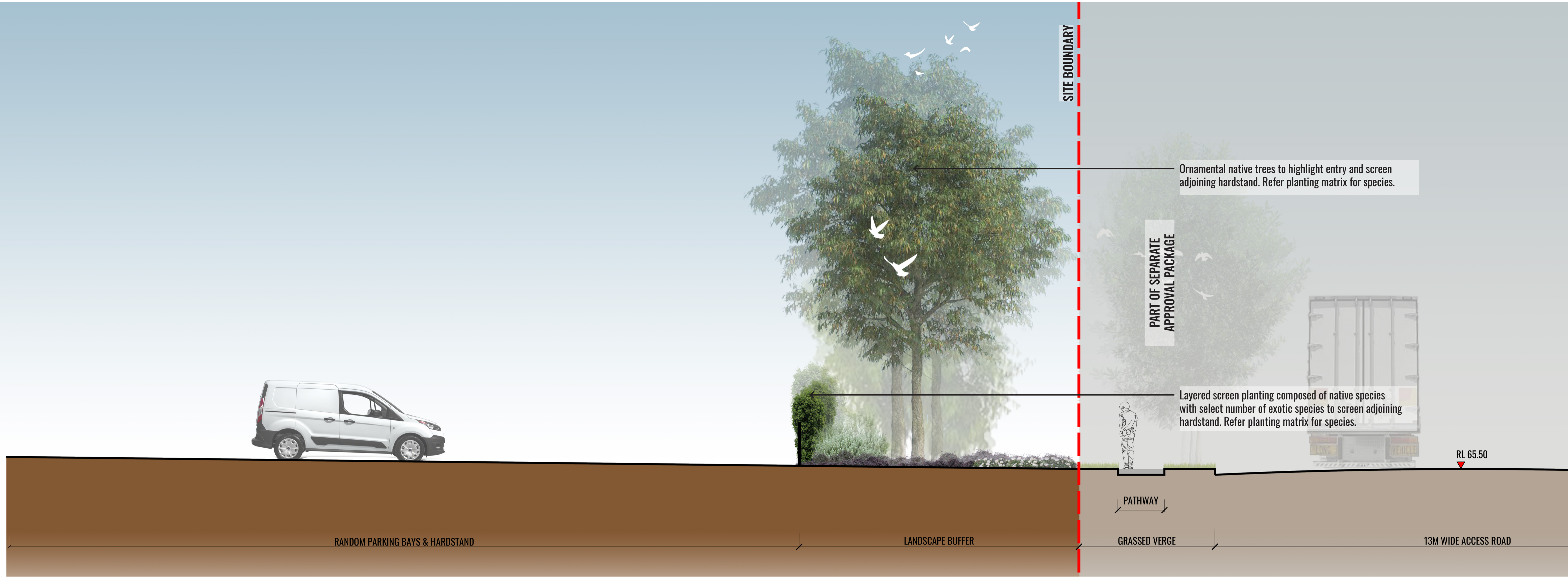

1 SECTION AA: FEATURE ENTRY PLANTING
SCALE 1:50

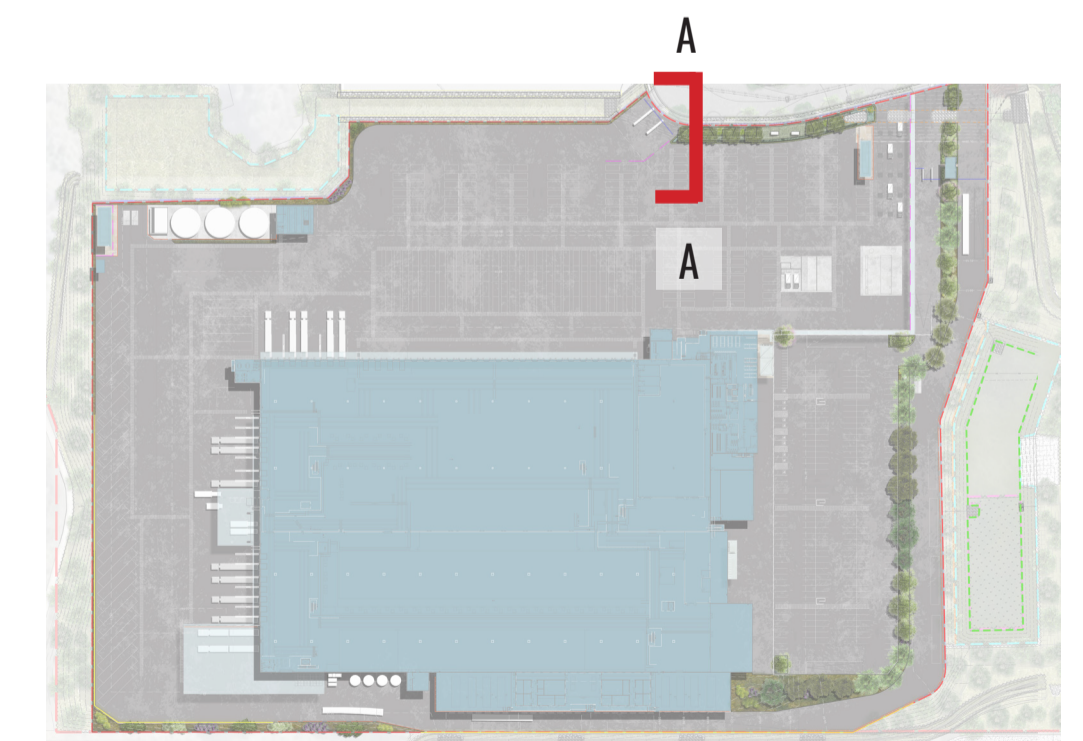

Drawing Title:
Landscape Section AA
DWG No:

LDA-08

GEOSCAPES
LANDSCAPE ARCHITECTS
Suite 215, 284 Victoria Ave, Chatswood NSW 2067 Ph. (02) 9411 1485
www.geoscapes.com.au
ABN 84 620 205 781 ACN 620 205 781

Architect:
LEFFLER SIMES ARCHITECTS

Client:
Charter Hall

Scale: 1:100 @ A1, 1:200 @ A3
Date: 24.06.2020
Job Number: 191129
North:
Project: **CUSTOMER FULFILLMENT CENTRE**
Horsley Drive Business Park - Stage 2, Wetherill Park, NSW 2164

Revision			FOR DEVELOPMENT APPLICATION	
Rev	Date	Description	Drawn	Checked
K	18.06.20	FOR DA	SW	BG
L	24.06.20	UPDATED FOR DA	SB	BG

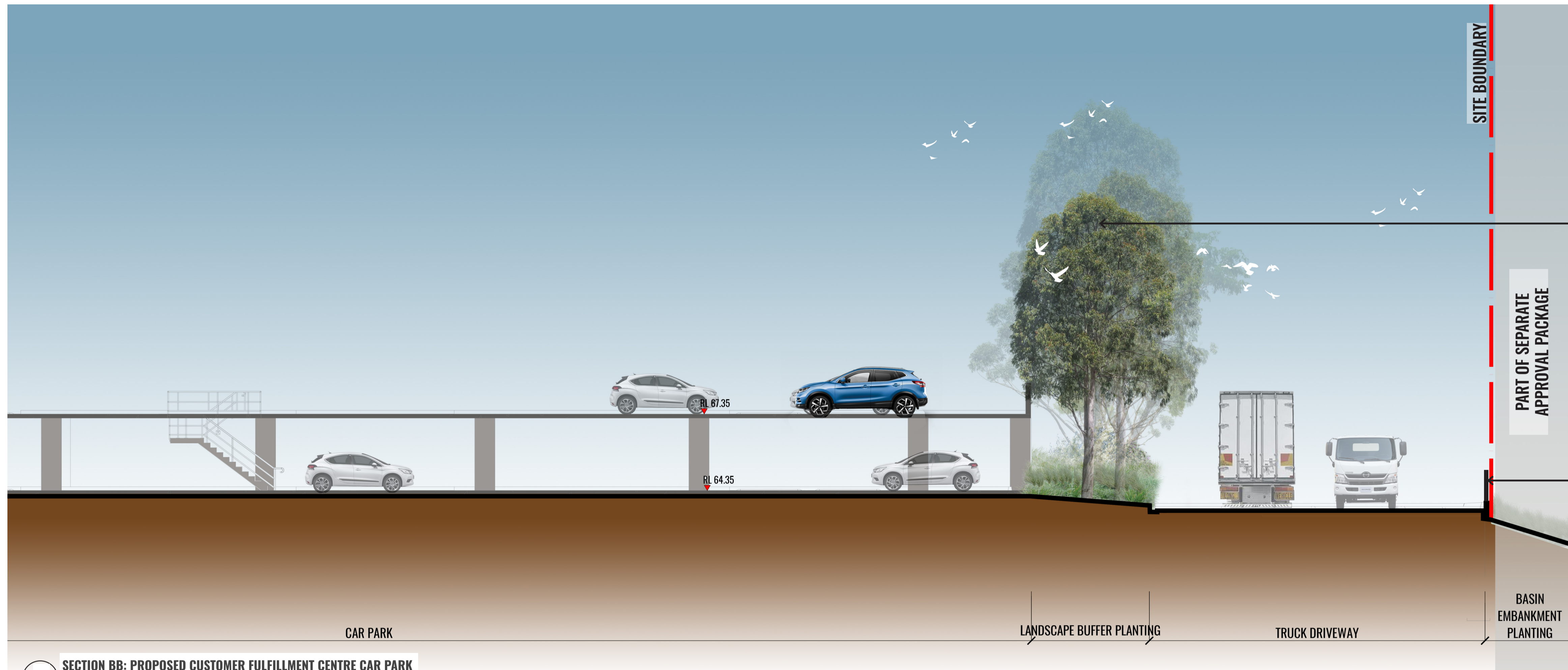

Native buffer planting of trees, shrubs, grasses & groundcovers to screen distribution centre car park from truck driveway & provide shade for cars. Plant species selection based on the prevalent Grey Box-Forest Red Gum grassy woodland vegetation. Proposed Planting to include trees, shrubs and grasses such as *Corymbia maculata*, *Eucalyptus crebra*, *Acacia paramttensis*, *Bursaria spinosa*, *Indigofera australis*, *Lomandra multiflora*, *Themeda australis*, *Pandorea pandorana*, etc.

1.1m high protection rail to Architect's detail

1 SECTION BB: PROPOSED CUSTOMER FULFILLMENT CENTRE CAR PARK
SCALE 1:100

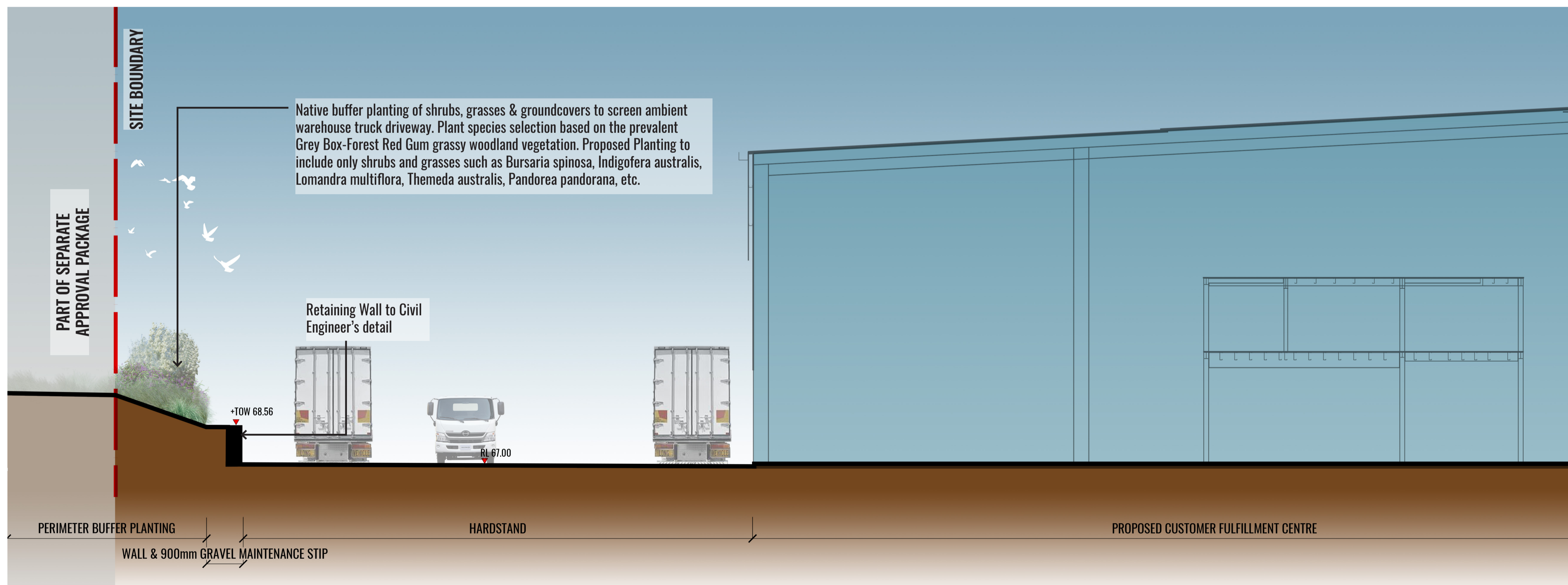

Native buffer planting of shrubs, grasses & groundcovers to screen ambient warehouse truck driveway. Plant species selection based on the prevalent Grey Box-Forest Red Gum grassy woodland vegetation. Proposed Planting to include only shrubs and grasses such as *Bursaria spinosa*, *Indigofera australis*, *Lomandra multiflora*, *Themeda australis*, *Pandorea pandorana*, etc.

Retaining Wall to Civil Engineer's detail

2 SECTION CC: SECTION THROUGH SOUTHERN RETAINING WALL
SCALE 1:100

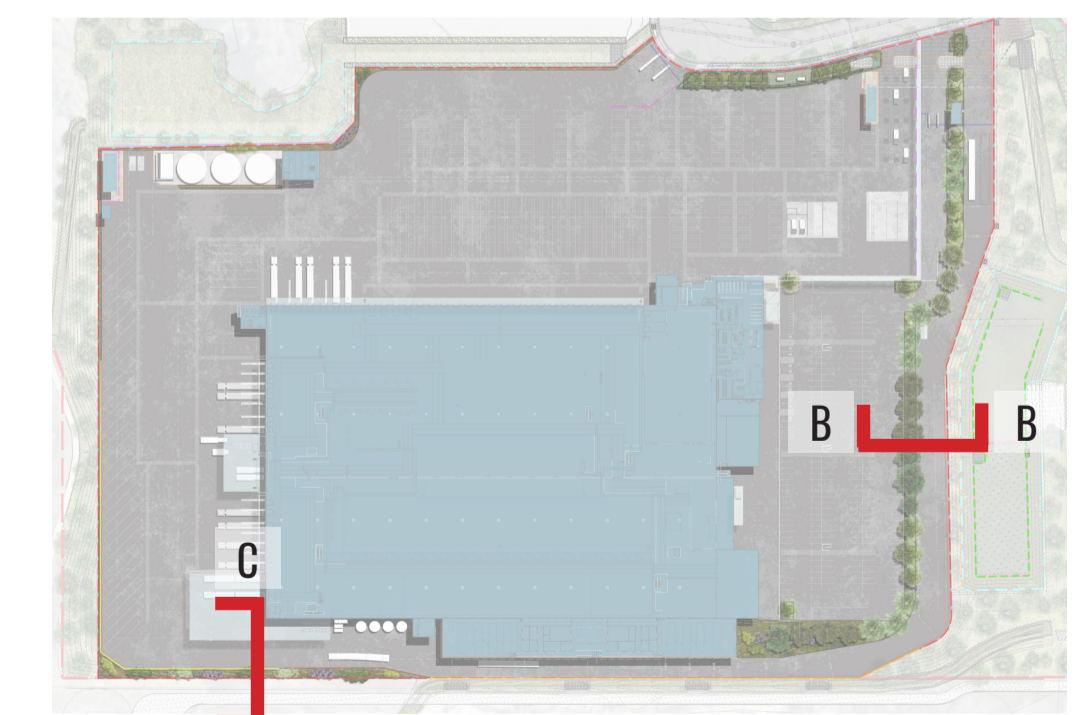

Drawing Title:
Landscape Section BB & CC
DWG No:
LDA-09

GEOSCAPES
LANDSCAPE ARCHITECTS
Suite 215, 284 Victoria Ave, Chatswood NSW 2067 Ph. (02) 9411 1485
www.geoscapes.com.au
ABN 84 620 205 781 ACN 620 205 781

Architect:
LEFFLER SIMES ARCHITECTS

Client:
Charter Hall

Scale: 1:75 @ A1
1:150 @ A3
Date: 24.06.2020
Job Number: 191129
North:
Project: **CUSTOMER FULFILLMENT CENTRE**
Horsley Drive Business Park - Stage 2, Wetherill Park, NSW 2164

Revision			FOR DEVELOPMENT APPLICATION	
Rev	Date	Description	Drawn	Checked
K	18.06.20	FOR DA	SW	BG
L	24.06.20	UPDATED FOR DA	SB	BG

PLANTING MATRICES

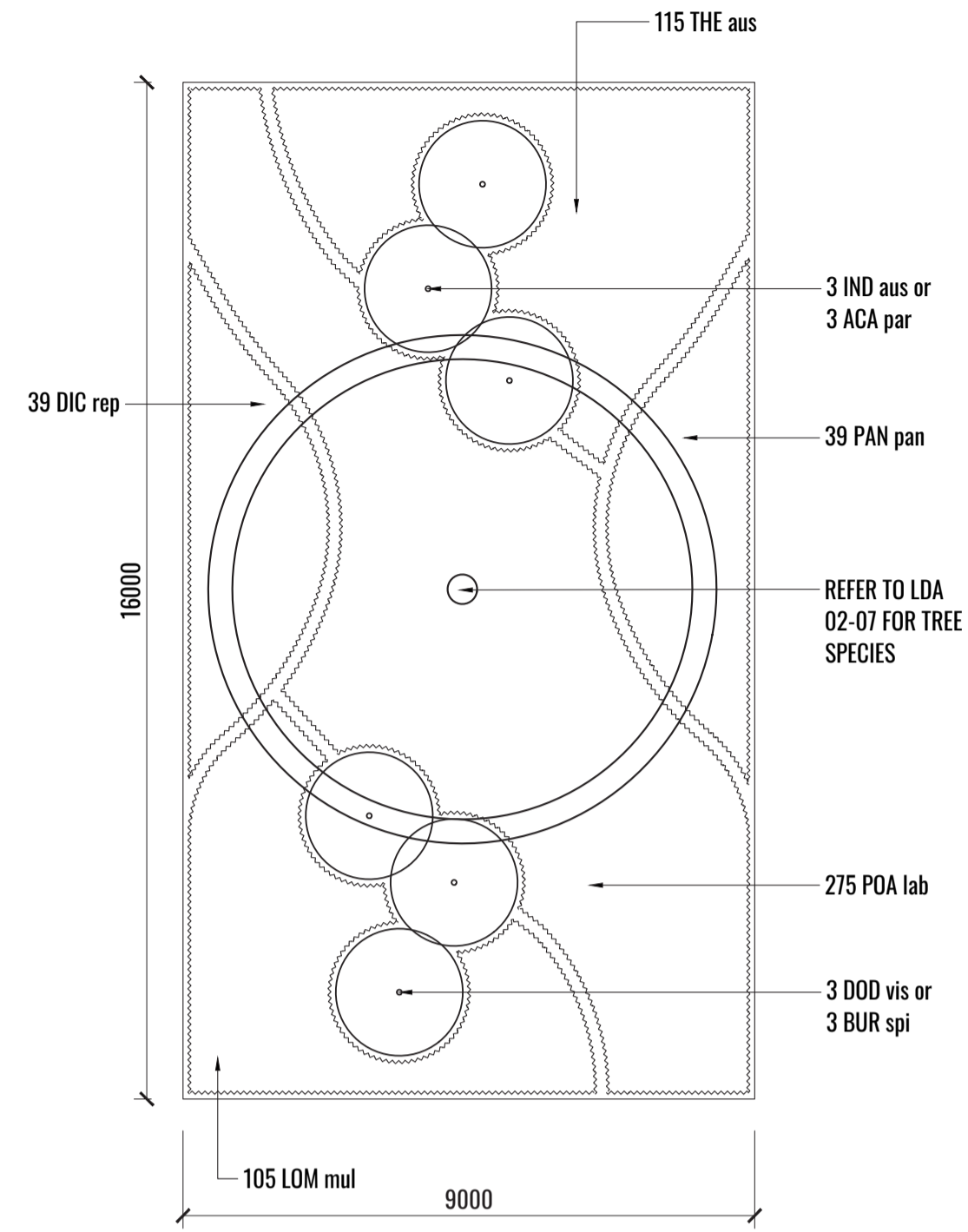

1 PERIMETER LANDSCAPE BUFFER TYPICAL MATRIX A (9M X 16M)
SCALE 1:100

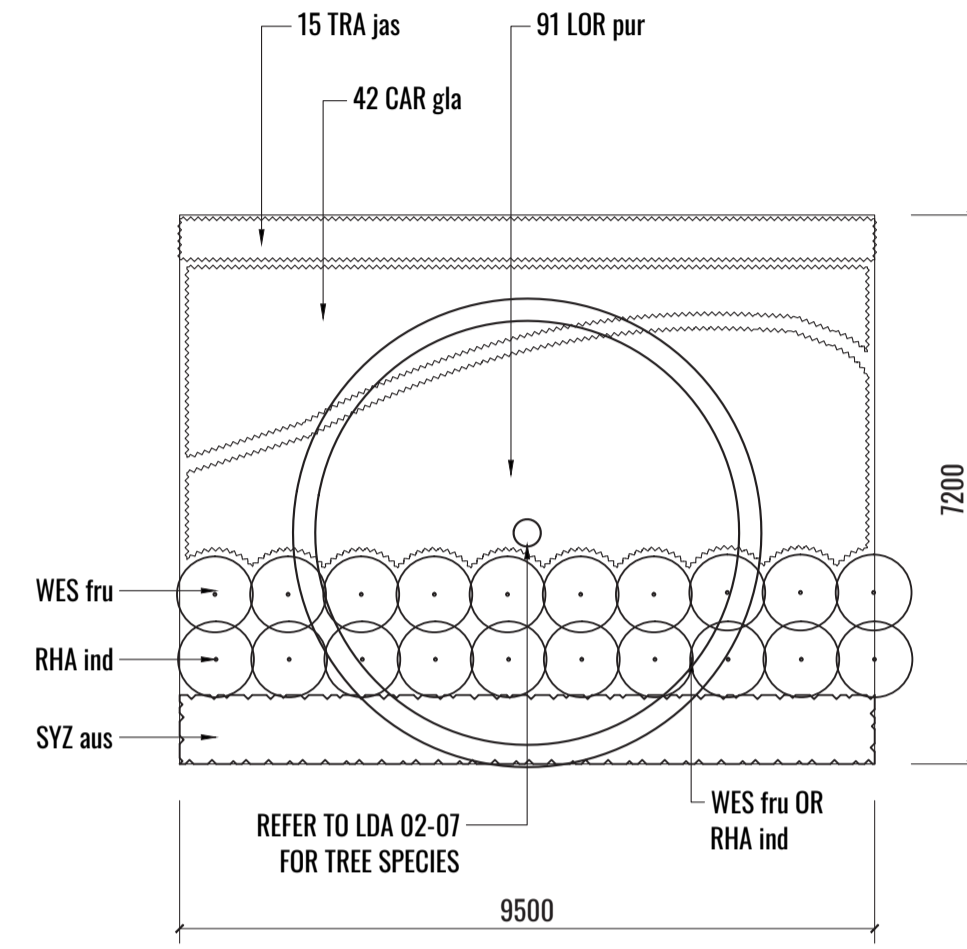

2 PERIMETER LANDSCAPE BUFFER TYPICAL MATRIX B1 (7.2M X 9.5M)
SCALE 1:100

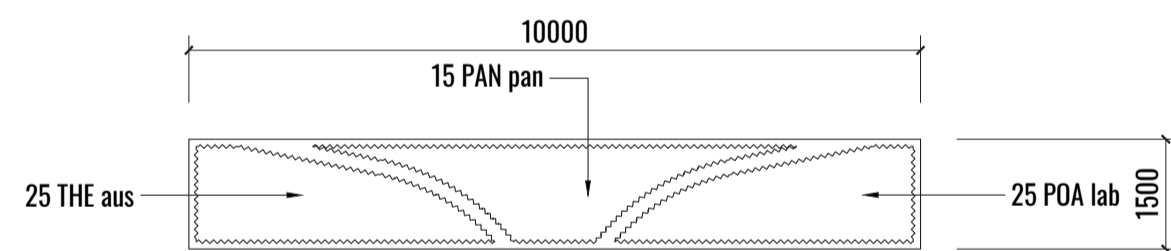

3 GROUNDCOVERS TYPICAL MATRIX C1 (10M X 1.5M)
SCALE 1:100

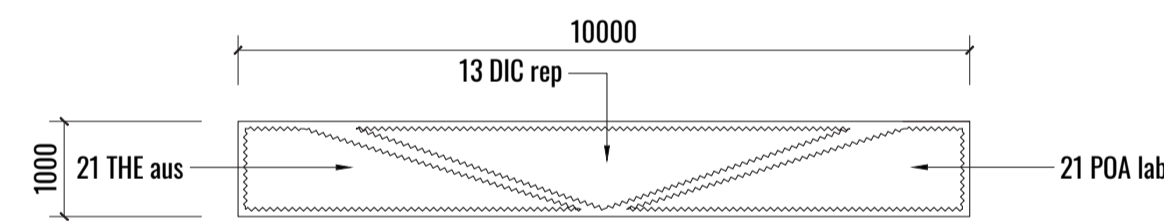

4 GROUNDCOVERS TYPICAL MATRIX C2 (10M X 1M)
SCALE 1:100

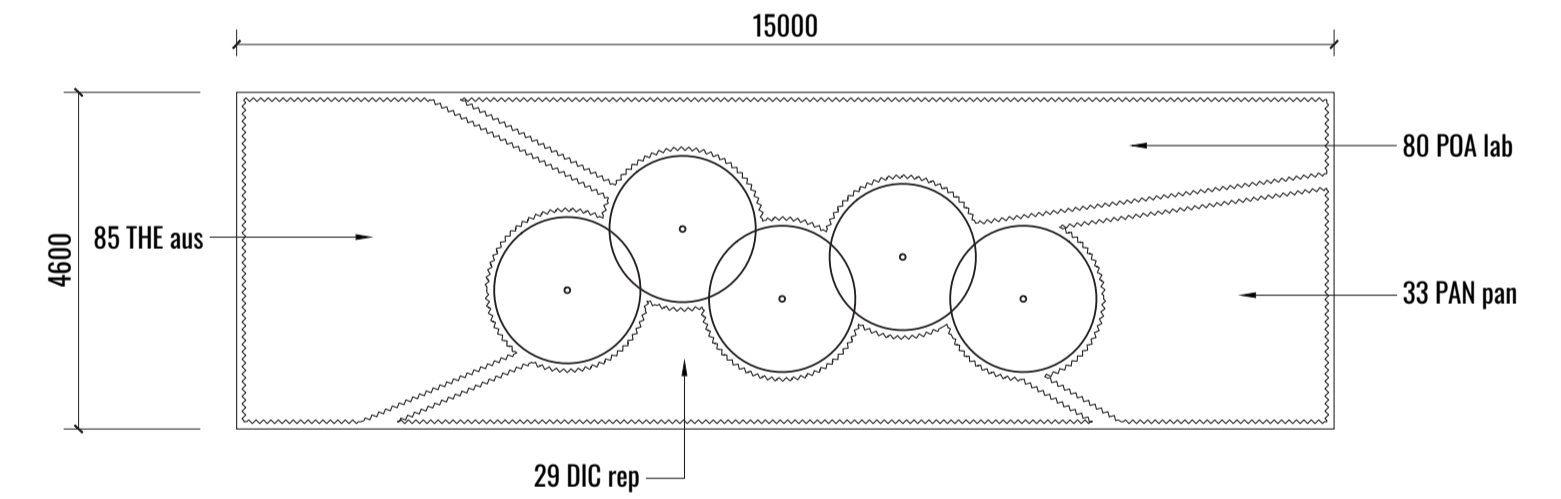

5 GROUNDCOVERS TYPICAL MATRIX C3 (15M X 4.6M)
SCALE 1:100

Drawing Title:
Planting Matrices
DWG No:

LDA-10

GEOSCAPES
LANDSCAPE ARCHITECTS
Suite 215, 284 Victoria Ave, Chatswood NSW 2067 Ph. (02) 9411 1485
www.geoscapes.com.au
ABN 84 620 205 781 ACN 620 205 781

Architect:
LEFFLER SIMES ARCHITECTS

Client:
Charter Hall

Scale: 1:100 @ A1 1:200 @ A3	Date: 24.06.2020	Job Number: 191129	North:	Revision					FOR DEVELOPMENT APPLICATION	
				Rev	Date	Description	Drawn	Checked		
				K	18.06.20	FOR DA	SW	BG		
				L	24.06.20	UPDATED FOR DA	SB	BG		
Project: CUSTOMER FULFILLMENT CENTRE Horsley Drive Business Park - Stage 2, Wetherill Park, NSW 2164										

SPECIFICATION & MAINTENANCE

Maintenance shall mean the care and maintenance of the landscape works by accepted horticultural practice as rectifying any defects that become apparent in the landscape works under normal use. The landscape contractor shall attend the site on a **weekly basis** to maintain the landscape works commencing from practical completion.

Rubbish Removal

The Landscape Contractor shall undertake rubbish removal from the site on a **weekly basis** to ensure the site remains in tidy condition.

Weed Eradication

Weed growth that may occur in grassed, planted or mulched areas is to be removed using environmentally acceptable methods i.e. non-residual glyphosate herbicide (e.g. 'Roundup', applied in accordance with the manufacturer's direction.

Tree Replacement

Trees shall show signs of healthy vigorous growth and be free from disease and not exhibit signs of stress prior to handover to the client. Any trees or plant that die or fail to thrive, or are damaged or stolen will be replaced. Replacement material shall have the initial maintenance period extended in accordance with the landscape contract conditions. Trees and plant materials shall be equal to the minimum requirements of species specified and approved material delivered to site. Should the condition decline from the approved sample the Superintendent reserves the right to reject the tree / plants.

Frequency: as required.

Stakes

Adjust and/or replace stakes and ties where required. Remove staking and guying when instructed by the Superintendent

Pruning

Selective pruning may be required during the establishment period to promote a balanced canopy structure. These activities shall be carried out to the best horticultural and industry practice. All pruned material is to be removed from site.

Mulched Surfaces

All planter beds and garden areas shall have a minimum depth of 75mm organic mulch. All mulch is to be free of deleterious matter such as soil, weeds, sticks and should conform to AS 4454.

Mulched surfaces are to be kept clean and tidy and free of any deleterious material and foreign matter. Reinstall depths to a uniform level of 75mm with mulch as specified, mulch to be free of any wood material impregnated with CCA or similar toxic treatment. Top up mulch levels prior to handover to client & estate management.

Watering

Implement an appropriate hand watering regime in areas not irrigated in association with current watering programme to maintain plant health and vigour. The program shall reflect seasonal conditions and plant species.

Frequency: Weekly or as required.

Soil In Natural Ground

Australian native garden beds to have soil installed consisting of 50% existing site topsoil and 50% new topsoil equal or equivalent to 'Native Low 'P' Mix' as supplied by Australian Native Landscapes. Soil to conform to AS4419 refer to typical detail.

Pest and Disease Control

The Landscape Contractor shall spray for pests and disease infestations when the pest and fungal attack has been positively identified and when their populations have increased to a point that will become detrimental to plant growth. Apply all pesticides to manufacturer's directions.

Frequency: weekly inspection

Fertilising

Generally check for signs of nutrient deficiencies (yellowing of leaves, failure to thrive), and adapt fertiliser regime to suit. Fertiliser should be applied at the beginning and the end of the (summer) growing season.

Irrigation

A sub surface dripper style, electrically automated self timed irrigation system is recommended to be supplied to all garden bed areas and planter container. Regular checks are to be made to ensure continued successful operation. The Landscape Contractor shall be responsible for coordination and engagement of a specialist irrigation designer and installation contractor to design, supply and install an automatic subterranean drip irrigation system to all raised planter beds.

The irrigation system will need to provide designated landscaped areas with enough water for vigorous healthy plant growth. As a general rule landscaped areas will need 20-25mm, species dependant, of water per week. The landscape Contractor will need to monitor natural rainfall using a rain switch in order to set irrigation flow rates accordingly on a monthly basis.

Standards

All grown or purchased plant stock must conform to all the conditions and requirements given in NATSPEC Guide: Specifying Trees. Soils to be in accordance with AS4419, mulching composts and conditioners to be in accordance with AS4454. Soils should conform to best practice specifications as listed in the Landscape Soils Handbook (Simon Leake & Elke Haege 2017).

TYPICAL DETAILS

TREE/SHRUB SIZE AND QUALITY TO BE TO NATSPEC STANDARD. SPECIES IS TO BE AS PER PLAN AND PLANT SCHEDULE. ENSURE ONLY HEALTHY AND VIGOROUS, DISEASE FREE, WELL MAINTAINED PLANTS ARE USED. TAKE CARE TO ENSURE FOLIAGE, BRANCHES, TRUNKS AND ROOT CROWNS ARE NOT DAMAGED BEFORE, DURING AND AFTER PLANTING. ENSURE OPTIMUM MAINTENANCE AND ESTABLISHMENT OF TREES/SHRUBS OCCURS AS SOON AS THEY ARE AT SITE.

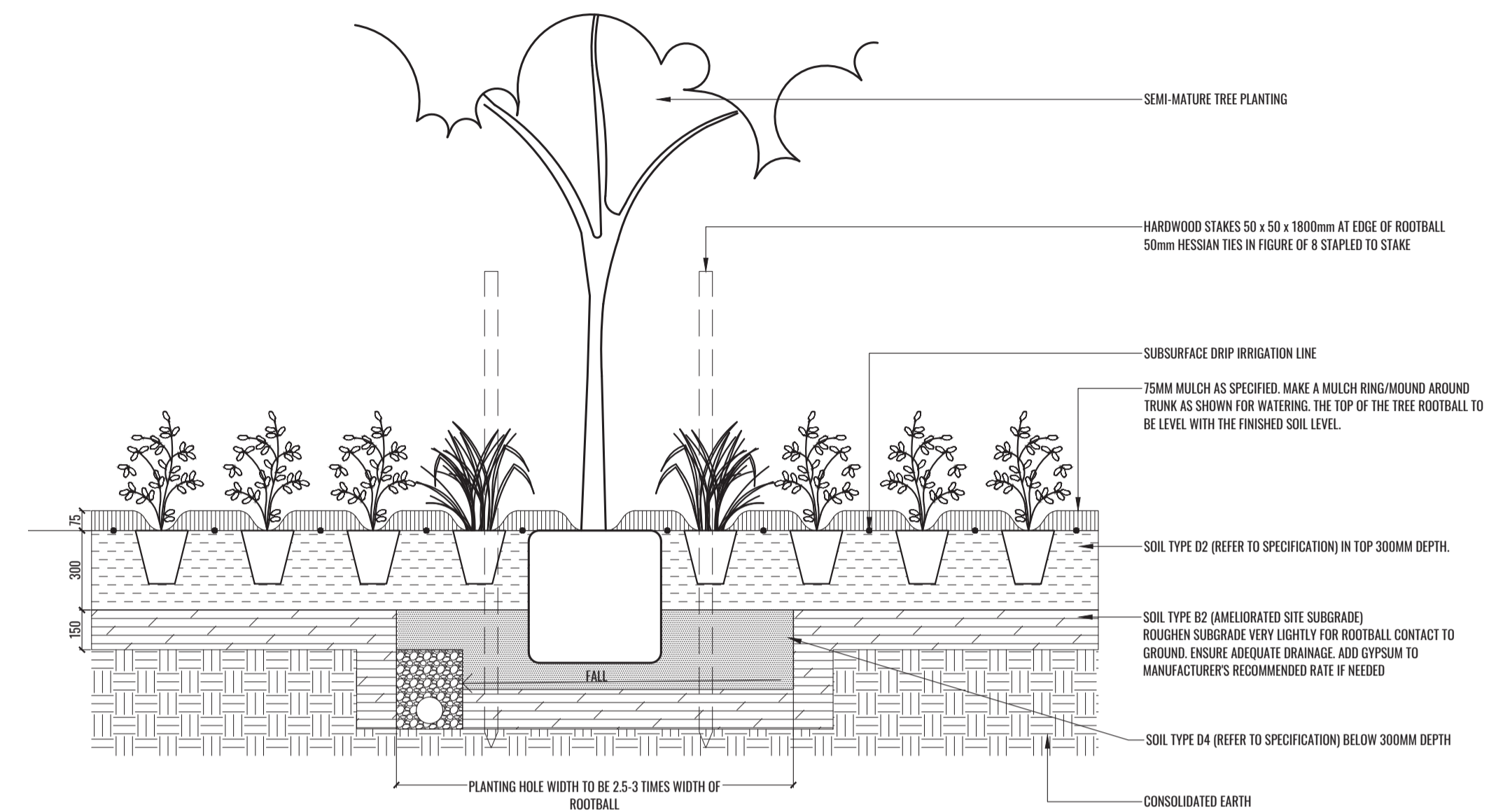

THOROUGHLY SOAK THE ROOTBALL OF TREE WITH FRESH WATER BEFORE TAKING OFF POT OR BAG. WHEN PLANTING HOLE IS COMPLETE USE A SHARP SPADE TO SHAVE OFF 20-50MM OF THE SIDES AND BASE OF ROOTBALL (TO ROOT PRUNE IT) BEFORE CAREFULLY PLACING INTO PLANTING HOLE. IF NORTH IS MARKED ON THE TREE, ENSURE ORIENTATION IS CORRECT WITH NORTH MARKING TO THE NORTH.
 - REMOVE ANY STAKES, TIES AND LABELS. WATER ROOTBALL THOROUGHLY.
 - TOP OF ROOTBALL TO FINISH FLUSH WITH TOP OF SOIL.

1 MASS PLANTING AND TREE DETAIL

TYPICAL SECTION

SCALE 1:20

NATSPEC QUALITY PLANTS TO BE INSTALLED. FOR PLANT SPECIES, QUANTITIES AND SIZE, REFER TO LANDSCAPE PLAN AND PLANTING SCHEDULE

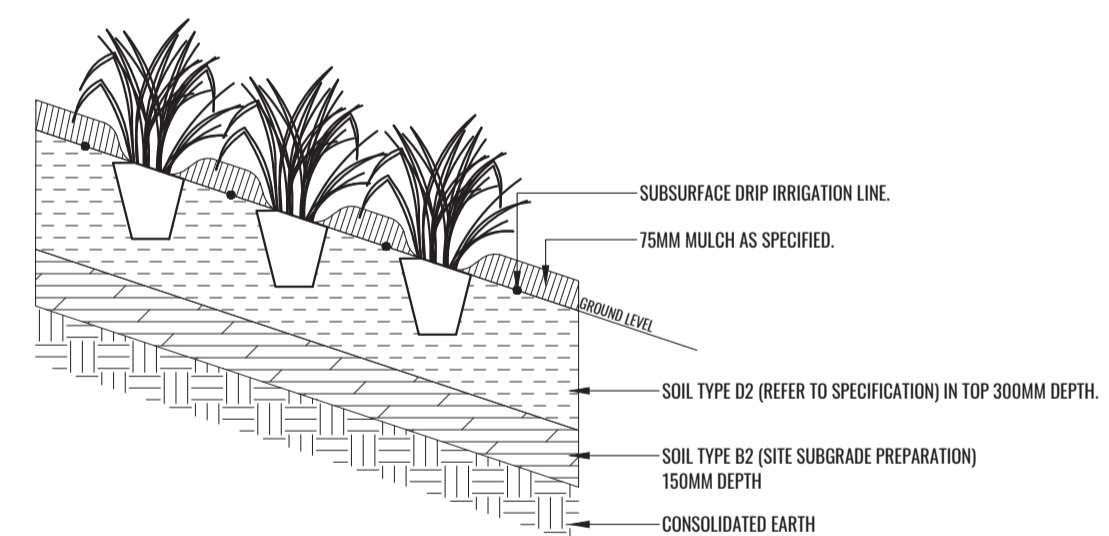

2 SLOPE PLANTING 1:3 OR FLATTER

TYPICAL SECTION

SCALE 1:20

Drawing Title:
Specification & Typical Details
 DWG No:

LDA-11

GEOSCAPES
 LANDSCAPE ARCHITECTS
 Suite 215, 284 Victoria Ave, Chatswood NSW 2067 Ph. (02) 9411 1485
 www.geoscapes.com.au
 ABN 84 620 205 781 ACN 620 205 781

Architect:
LEFFLER SIMES ARCHITECTS

Client:
Charter Hall

Scale:	Date:	Job Number:	North:	Revision					FOR DEVELOPMENT APPLICATION	
As shown @ A1	24.06.2020	191129		Rev	Date	Description	Drawn	Checked		
				K	18.06.20	FOR DA	SW	BG		
				L	24.06.20	UPDATED FOR DA	SB	BG		
Project:	CUSTOMER FULFILLMENT CENTRE									
	Horsley Drive Business Park - Stage 2, Wetherill Park, NSW 2164									

PLANTING SCHEDULE

DA Plant Schedule

PLANT CODE	BOTANICAL NAME	COMMON NAME	MATURE HEIGHT	NATIVE	POT SIZE	PLANTING DENSITY	QTY**
General trees							
COR MAC	<i>Corymbia maculata</i>	Spotted Gum	20m	✓	45L	As Shown	8
EUC CRE	<i>Eucalyptus crebra</i>	Narrow leaved Ironbark	20m	✓	45L	As Shown	4
EUC MOL	<i>Eucalyptus moluccana</i>	Grey Box	25m	✓	45L	As Shown	8
EUC TER	<i>Eucalyptus tereticornis</i>	Forest Red Gum	20m	✓	45L	As Shown	3
LAG ACO	<i>Lagerstroemia indica 'Acoma'</i>	Indian Summer White Crepe Myrtle	3m		45L	As Shown	3
LAG SIO	<i>Lagerstroemia indica x fauriei 'Sioux'</i>	Hot Musk Pink Crepe Myrtle	5m		45L	As Shown	3
MEL LIN	<i>Melaleuca linariifolia</i>	Snow-in-Summer	10m	✓	45L	As Shown	3
WAT FLO	<i>Waterhousea floribunda 'Green Avenue'</i>	Weeping Lilly Pilly	10m	✓	45L	As Shown	7
Shrubs and hedging							
AGA att	<i>Agave attenuata</i>	Foxtail Agave	1.2m		200mm	As Shown	43
ACA par	<i>Acacia parramattensis</i>	Parramatta Wattle	4m	✓	200mm	As Shown	38
BUR spi	<i>Bursaria spinosa</i>	Blackthorn	3m	✓	200mm	As Shown	41
DOD vis	<i>Dodonaea viscosa subsp. cuneata</i>	Sticky Hop Bush	3m	✓	200mm	As Shown	35
DOR exc	<i>Doryanthes excelsa</i>	Gymea Lilly	1.5m	✓	200mm	As Shown	27
IND aus	<i>Indigofera australis</i>	Australian Indigo	2m	✓	200mm	As Shown	38
RHA ind	<i>Rhapheolepis indica 'Cosmic Pink'</i>	Indian Hawthorn	0.5m		200mm	500mm centres	48
SYZ aus	<i>Syzygium australe 'Tiny Trev'</i>	Lilly Pilly	1.2m	✓	200mm	750mm centres	99
WES fru	<i>Westringia fuitcosa 'Aussie Box'</i>	Native Rosemary	0.6m	✓	200mm	500mm centres	53
Grasses & groundcovers							
BRA mul	<i>Brachyscome multifida</i>	Rock Daisy	0.3m	✓	Tubestock	3/m2	153
CAR gla	<i>Carpobrotus glaucescens</i>	Native Pigface	0.3m	✓	140mm	3/m2	270
DIA cae	<i>Dianella caerulea 'Breeze'</i>	Native Flax	0.5m	✓	Tubestock	5/m2	730
DIC rep	<i>Dichondra repens</i>	Kidney Weed	0.2m	✓	140mm	3/m2	1487
LOR pur	<i>Loropetalum 'Purple Pixie'</i>	Purple Loropetuum	0.5m		140mm	4/m2	286
LOM mul	<i>Lomandra multiflora subsp. multiflora</i>	Mat-rush	0.6m	✓	Tubestock	5/m2	2235
MYO par	<i>Myoporum parvifolium 'Yareena'</i>	Creeping boobialla	0.2m	✓	Tubestock	3/m2	44
PAN pan	<i>Pandorea pandorana</i>	Wonga Wonga Vine	0.25m	✓	200mm	3/m2	1664
POA lab	<i>Poa labillardieri</i>	Tussock Grass	1m	✓	Tubestock	5/m2	3520
SEN man	<i>Senecio mandraliscae</i>	Blue Chalksticks	0.3m		140mm	3/m2	329
TRA jas	<i>Trachelospermum jasminoides</i>	Star Jasmine	0.2m		140mm	3/m2	312
THE aus	<i>Themeda australis</i>	Kangaroo Grass	0.8m	✓	Tubestock	5/m2	3310

** Final numbers to be confirmed at Construction Certificate stage

PLANT IMAGES



Waterhousea floribunda 'Green Avenue'



Corymbia maculata



Eucalyptus crebra



Eucalyptus moluccana



Eucalyptus tereticornis



Lagerstroemia indica 'Acoma'



Lagerstroemia indica x fauriei 'Sioux'



Melaleuca linariifolia

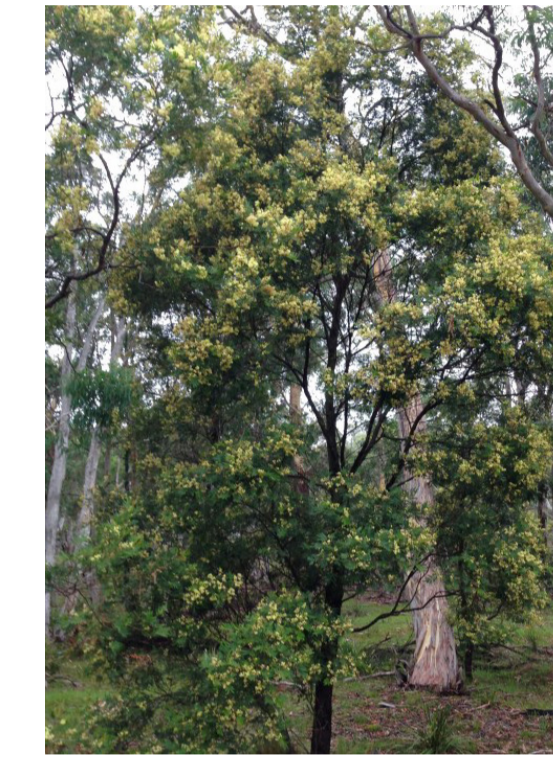

Acacia parramattensis



Bursaria spinosa



Dodonaea viscosa



Dichondra repens



Indigofera australis



Lomandra multiflora



Poa labillardieri



Themeda australis

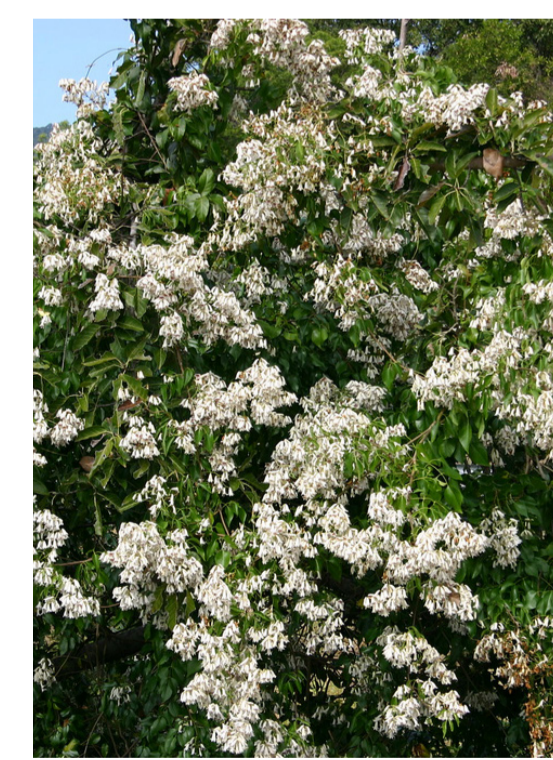

Pandorea pandorana



Agave attenuata



Rhapheolepis indica 'Cosmic Pink'

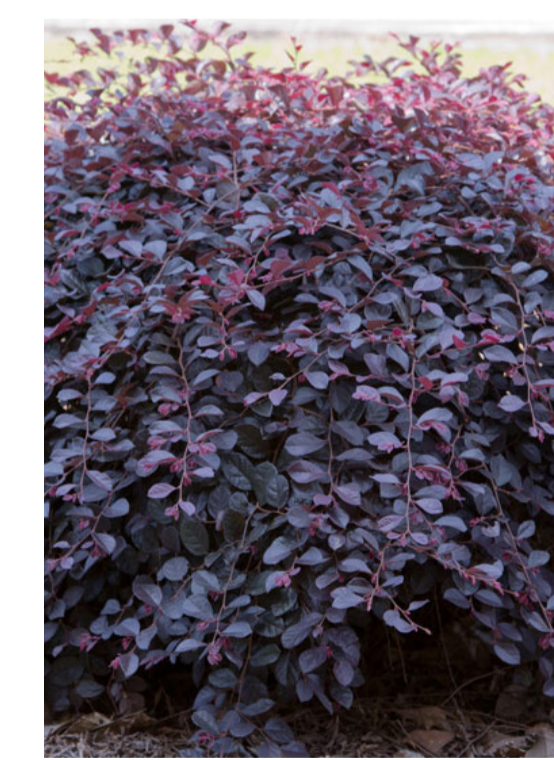

Loropetalum 'Purple Pixie'

Drawing Title:
Planting Schedule & Imagery
DWG No:

LDA-12

GEOSCAPES
LANDSCAPE ARCHITECTS
Suite 215, 284 Victoria Ave, Chatswood NSW 2067 Ph. (02) 9411 1485
www.geoscapes.com.au
ABN 84 620 205 781 ACN 620 205 781

Architect:
LEFFLER SIMES ARCHITECTS

Client:
Charter Hall

Scale: NTS	Date: 24.06.2020	Job Number: 191129	North:	Revision				FOR DEVELOPMENT APPLICATION	
				Rev	Date	Description	Drawn	Checked	
				K	18.06.20	FOR DA	SW	BG	
				L	24.06.20	UPDATED FOR DA	SB	BG	
Project: CUSTOMER FULFILLMENT CENTRE Horsley Drive Business Park - Stage 2, Wetherill Park, NSW 2164									