



PROPOSED SHOP-TOP HOUSING DEVELOPMENT

20-22 ATCHISON STREET, ST LEONARDS

WASTE MANAGEMENT PLAN

PROPOSED SHOP-TOP HOUSING DEVELOPMENT, 20-22 ATCHISON STREET, ST LEONARDS

Client: Setia Development Company Pty Ltd

Report Reference: 25191W

File Path: Y:\2025\25191 - 20-22 Atchison Street, St Leonards\08 Reports\25191WREP01F03.docx

Thursday, March 12, 2026

Document Control

Version:	Prepared By:	Position:	Date:	Reviewed By:	Position:	Date:	Authorised By:	Position:	Date:
D01	Hari Haran	Environmental Consultant	23 July 2025	Tom Bloomfield	Director	23 July 2025	Tom Bloomfield	Director	23 July 2025
D02	Hari Haran	Environmental Consultant	15 August 2025	Tom Bloomfield	Director	15 August 2025	Tom Bloomfield	Director	15 August 2025
F01	Hari Haran	Environmental Consultant	18 September 2025	Tom Bloomfield	Director	18 September 2025	Tom Bloomfield	Director	18 September 2025
F02							Tom Bloomfield	Director	10 March 2026
F03									12 March 2026

© Sustainable Transport Surveys Pty Ltd All Rights Reserved. Copyright in the whole and every part of this document belongs to Sustainable Transport Surveys Pty Ltd and may not be used, sold, transferred, copied or reproduced in whole or in part in any manner or form or in or on any media to any person without the prior written consent of Sustainable Transport Surveys Pty Ltd.

This document is produced by Sustainable Transport Surveys for the benefits and use by the client in accordance with the terms of engagement. Sustainable Transport Surveys does not and shall not assume any responsibility or liability whatsoever to any third party arising out of any use or reliance by any third party on the content of this document

MELBOURNE

Level 6, 350 Collins St Melbourne VIC 3000

T: +61 3 9020 4225

SYDNEY

Level 6, 201 Kent St Sydney NSW 2000

T: +61 2 9068 7995

HOBART

Level 5, 24 Davey St Hobart TAS 7000

T: +61 400 535 634

CANBERRA

Level 2, 28 Ainslie Pl Canberra ACT 2601

T: +61 2 9068 7995

ADELAIDE

Level 21, 25 Grenfell St Adelaide SA 5000

T: +61 8 8484 2331

DARWIN

Level 1 Suite 2A, 82 Smith St Darwin City NT 0800

T: +61 8 8484 2331

PERTH

Level 25, 108 St Georges Tce. Perth WA 6000

T: +61 8 6557 8888

www.salt3.com.au

TRAFFIC ENGINEERS / WASTE ENGINEERS / TRANSPORT PLANNERS / ROAD SAFETY AUDITORS



EXECUTIVE SUMMARY

SALT has been engaged by Setia Development Company Pty Ltd to prepare a Waste Management Plan (WMP) for a proposed shop-top housing development located at 20-22 Atchison Street, St Leonards.

SALT understands that the proposal involves the development of 1,938m² of commercial tenancies and 181 apartments, consisting of 74 one-bedroom apartments, 85 two-bedroom apartments and 22 three-bedroom apartments.

Residential waste would be stored on-site in the residential bin room located at lower ground level.

Residential waste would be collected by council, with:

- 7 x 1,100L garbage bins collected weekly;
- 6 x 1,100L commingled recycling bins collected weekly;
- 38 x 240L organics bins collected fortnightly; and
- A separate 39m² storage room allocated for bulky waste (collected as-required).

Commercial waste would be stored on-site in the commercial bin room located at lower ground level.

Commercial waste would be collected by private contractor, with:

- 1 x 1,100L garbage bins collected once per week;
- 1 x 1,100L commingled recycling bin collected once per week;
- 2 x 240L organics bins collected once per week;
- 1 x 1,100L paper/cardboard bin collected once per week; and
- 2m² storage area allocated for bulky waste (collected as-required).

Both Council and private contractor waste vehicles would stop on the dedicated waste loading dock. Vehicle operators would ferry waste bins from the temporary bin holding area to the collection vehicle and return upon emptying.

Building Management is responsible for returning the bins to the respective bin rooms following collection.

In the opinion of SALT, the enclosed Waste Management Plan would provide efficient waste management for the proposed development. This report must be read in detail prior to implementation of the waste management strategy.

TABLE OF CONTENTS

1	INTRODUCTION	1
1.1	RESPONSE TO NORTH SYDNEY COUNCIL RFI.....	1
2	PROJECT DESCRIPTION	2
3	THE SITE	2
4	INCLUDED IN THIS REPORT	3
5	LAND USE	4
6	DEMOLITION AND CONSTRUCTION WASTE RESPONSIBILITIES	4
6.1	WASTE CLASSIFICATION.....	4
6.2	WASTE MANAGEMENT HIERARCHY.....	5
7	DEMOLITION AND CONSTRUCTION WASTE MANAGEMENT PLAN	5
7.1	DEMOLITION WASTE GENERATION AND MANAGEMENT PRACTICES.....	5
7.2	CONSTRUCTION WASTE GENERATION AND MANAGEMENT PRACTICES.....	6
7.3	WASTE STORAGE AND COLLECTION REQUIREMENTS.....	8
7.4	BIN TYPE, QUANTITY AND DIMENSIONS.....	8
7.5	WASTE SIGNAGE AND SAFETY.....	9
8	CONSTRUCTION AND DEMOLITION SITE MANAGEMENT	9
8.1	ASBESTOS, AND OTHER HAZARDOUS/CONTAMINATED WASTE.....	9
8.2	LIQUID WASTE MANAGEMENT AND HANDLING.....	10
8.3	LITTER MANAGEMENT AND STORMWATER POLLUTION PREVENTION.....	10
8.4	TRAINING.....	11
8.5	MONITORING AND COMPLIANCE.....	11
9	BIN SUPPLIER AND RECYCLING DIRECTORY	11
10	RESIDENTIAL WASTE MANAGEMENT PLAN	13
10.1	WASTE GENERATION.....	13
10.2	WASTE SYSTEMS.....	13
10.2.1	DUAL CHUTE.....	13
10.2.2	GARBAGE (GENERAL WASTE).....	14
10.2.3	COMMINGLED RECYCLING.....	14
10.2.4	ORGANICS.....	14
10.2.5	BULKY WASTE.....	14
10.3	BIN QUANTITY, SIZE AND COLLECTION FREQUENCY.....	14
10.4	BIN COLOUR AND SUPPLIER.....	15
10.5	WASTE STORAGE AREA.....	15
10.6	WASTE COLLECTION.....	15
11	COMMERCIAL WASTE MANAGEMENT PLAN	16
11.1	WASTE GENERATION.....	16
11.2	WASTE SYSTEMS.....	16
11.2.1	GARBAGE (GENERAL WASTE).....	17
11.2.2	COMMINGLED RECYCLING.....	17
11.2.3	ORGANICS.....	17
11.2.4	PAPER/CARDBOARD RECYCLING.....	17
11.2.5	BULKY WASTE.....	18
11.3	BIN QUANTITY, SIZE AND COLLECTION FREQUENCY.....	18
11.4	BIN COLOUR AND SUPPLIER.....	18
11.5	WASTE STORAGE AREA.....	18
11.6	WASTE COLLECTION.....	19
12	RESPONSIBILITIES	19

13	SIGNAGE.....	20
14	SUSTAINABILITY ACTION PLAN AND INITIATIVES.....	20
15	WASTE AREA DESIGN REQUIREMENTS.....	21
15.1	VENTILATION.....	21
15.2	LITTER MANAGEMENT, WASHING AND STORMWATER POLLUTION PREVENTION.....	21
15.3	NOISE REDUCTION.....	21
15.4	DDA COMPLIANCE.....	21
16	RISK AND HAZARD ANALYSIS.....	22
17	SUPPLIER CONTACT INFORMATION.....	24
17.1	EQUIPMENT SUPPLIERS.....	24
17.1.1	DUAL CHUTE SYSTEM.....	24
17.1.2	BIN SUPPLIER.....	24
17.2	WASTE COLLECTION CONTRACTORS.....	24
17.2.1	GARBAGE, RECYCLING AND ORGANICS.....	24
17.3	BIN WASHING SERVICES.....	25
18	PURPOSE AND LIMITATIONS.....	25
APPENDIX 1	DESIGN DRAWINGS.....	26
APPENDIX 2	SWEPT PATH ANALYSIS.....	27
APPENDIX 3	COUNCIL WASTE COLLECTION VEHICLE SPECIFICATION.....	28

LIST OF FIGURES

FIGURE 1	THE SITE.....	3
FIGURE 2	WASTE MANAGEMENT HIERARCHY.....	5
FIGURE 3	SKIP BIN SIZE DIMENSIONS.....	9
FIGURE 4	NSW EPA SIGNAGE.....	9
FIGURE 5	AUSTRALIAN STANDARD COMPOSTABLE LOGO.....	14
FIGURE 6	AUSTRALIAN STANDARD COMPOSTABLE LOGO.....	17
FIGURE 7	NSW EPA SIGNAGE.....	20

LIST OF TABLES

TABLE 1	WASTE RELATED SEARS.....	1
TABLE 2	WASTE GENERATION RATES FOR DEMOLITION MATERIALS.....	5
TABLE 3	ESTIMATED DEMOLITION WASTE GENERATION VOLUMES AND MANAGEMENT OPTIONS.....	6
TABLE 4	ESTIMATE WASTE GENERATION RATES FOR CONSTRUCTION MATERIALS.....	7
TABLE 5	ESTIMATED CONSTRUCTION WASTE GENERATION VOLUMES AND MANAGEMENT OPTIONS.....	7
TABLE 6	BIN SUPPLIER AND RECYCLING DIRECTORY.....	12
TABLE 7	WASTE GENERATION RATES.....	13
TABLE 8	WASTE GENERATION ASSESSMENT.....	13
TABLE 9	BIN SIZE AND COLLECTION FREQUENCY.....	14
TABLE 10	TYPICAL WASTE BIN DIMENSIONS.....	15
TABLE 11	WASTE AREA SPACE REQUIREMENTS.....	15
TABLE 12	WASTE GENERATION RATES.....	16
TABLE 13	WASTE GENERATION ASSESSMENT.....	16
TABLE 14	BIN SIZE AND COLLECTION FREQUENCY.....	18
TABLE 15	TYPICAL WASTE BIN DIMENSIONS.....	18
TABLE 16	WASTE AREA SPACE REQUIREMENTS.....	19
TABLE 17	POTENTIAL RISKS AND CONTROL METHODS DURING WASTE COLLECTIONS.....	23
TABLE 18	HIGH LEVEL PURCHASING SCHEDULE (RESIDENTIAL BIN ROOM).....	24
TABLE 19	HIGH LEVEL PURCHASING SCHEDULE (COMMERCIAL BIN ROOM).....	24

1 INTRODUCTION

SALT has been requested by Setia Development Company Pty Ltd to prepare a Waste Management Plan for a proposed shop-top housing development located at 20-22 Atchison Street, St Leonards.

This Waste Management Plan (WMP) has been prepared to support a State Significant Development Application (SSDA) SSD-87486461 for the site at 20-22 Atchison Street, St Leonards (the site).

The Minister for Planning, or their delegate, is the consent authority for the SSDA and this application is lodged with the NSW Department of Planning, Housing and Infrastructure (DPHI) for assessment.

This report has been prepared in response to the requirements contained within the Secretary's Environmental Assessment Requirements (SEARs) dated 9 July 2025 (SSD-87486461). Specifically, this report has been prepared to respond to the following SEARs:

Table 1 Waste related SEARs

Secretary's Environmental Assessment Requirements	Description of Requirement	Report Section
17. Waste Management	<ul style="list-style-type: none"> Provide the measures to be implemented to manage, reuse, recycle and safely dispose of waste, including in accordance with any council waste management requirements. 	Section 10, 11, 12, 13, 14 and 15
	<ul style="list-style-type: none"> Identify appropriately sited waste storage areas, collection access paths/roads, and appropriate servicing arrangements for the site. 	Section 10, 11 and 12

1.1 RESPONSE TO NORTH SYDNEY COUNCIL RFI

This revision of the Waste Management Plan includes additional information to address the following RFI item received from North Sydney Council regarding waste collection:

'Confirm that the development has been designed to enable on-site waste collection by Council's waste collection fleet, including adequate access and manoeuvring space.'

SALT has liaised with North Sydney Council on the matter and Council is now comfortable with the proposed collection arrangements, their contractor has concerns regarding trucks potentially causing damage.

To address the above RFI, a waste truck swept path has been completed using the specifications of the collection vehicle used by Council's contractors and indicates the truck can enter and exit the site without hitting any objects, which in our expert opinion indicates a satisfactory waste collection arrangement. It is further noted that a 600mm clearance has been adopted for the swept path assessment, which is double the minimum required by AS2890.2 (Clause 5.4, item a) of 300mm for low-speed manoeuvres. This provides a more conservative assessment of the vehicle movement.

If considered necessary, a Loading Management Plan can also be prepared for the site. This would include a signage and line marking plan for the loading area including warning signage, pedestrian alerts, convex mirrors and other relevant management devices to ensure safety within the loading area.

A summary of the correspondence between SALT and North Sydney Council is also provided as follows:

- Email from SALT to North Sydney Council on Friday 13 February 2026 requesting the specification of the waste contractor's collection vehicles
- Email from North Sydney Council to SALT on Friday 13 February 2026 providing specifications for two vehicles, one 7.2m long and the other 10.5m long (specification attached in Appendix 3).
- Email from SALT to North Sydney Council on Wednesday 18 February 2026 providing swept path analysis of the 10.5m long truck accessing the loading bay, however requiring a corrective movement to reverse into the bay



- Email from North Sydney Council to SALT on Friday 20 February 2026 advising that their waste contractor believed the site to be too tight for their trucks to manoeuvre and requesting off site collection with temporary holding bay at Atchison Lane
- Email from SALT to North Sydney Council on Wednesday 25 February 2026 providing swept path analysis of the truck entering the site from the west, which does not require a corrective movement to enter the loading bay. Also advising that a temporary holding bay at Atchison Lane would not be feasible due to the location of services infrastructure that cannot be moved.
- Email from North Sydney Council to SALT on Tuesday 3 March 2026 requesting further information regarding confirmation of the vehicle clearances used and for an exit swept path to be provided.
- Email from SALT to North Sydney Council on Tuesday 3 March 2026 advising that the clearance shown on swept paths is 600mm and also providing an exit swept path for the collection vehicle.
- Email from North Sydney Council to SALT on Friday 6 March 2026 advising that Council's Traffic Engineer deemed the swept paths to be acceptable, however a response from Council's contractor had not yet been received.
- Email from North Sydney Council to SALT on Friday 6 March 2026 advising that the contractor was concerned it was too tight and could result in damage.
- Email from SALT to North Sydney Council on Friday 6 March 2026 reiterating that swept paths show safe access for the collection vehicle with sufficient clearance and that there is no alternative other than a private waste collection if Council's contractor is unwilling to collect the bins.
- Email from North Sydney Council to SALT on Thursday 12 March 2026 confirming that the proposed plan was acceptable to Council.

2 PROJECT DESCRIPTION

The application seeks development consent for an SSDA which will facilitate the redevelopment of the site for a shop top housing development using the recently introduced provisions under the Transit Oriented Development (TOD) reforms.

The project seeks consent for:

- Demolition of existing buildings on site and tree removal.
- Construction of a 40-storey shop top housing development comprising:
 - 4-storey mixed-use (commercial, residential and retail) podium with a retail tenancy at ground level (Atchison Street frontage).
 - 36 levels of residential apartments and residential amenities within the tower.
 - Landscaping and public amenities along the Mitchell Street eastern elevation at ground level.
 - Consolidated vehicular and loading access from Atchison Lane.
 - 5 storey basement accommodating car, bicycle and motorcycle parking, storage, plant and end of trip facilities (EOTF) for the commercial component.
- Amalgamation of Lot 1 in DP740017 and Lot 120 DP564606.
- 10% of residential floor space to be used for affordable housing via monetary contribution.
- Storage areas, utilities and service provision.

Refer to Architectural Plans prepared by Cox Architecture appended to the Environmental Impact Statement.

3 THE SITE

The site occupies a strategic location in the St Leonards Crows Nest precinct and is in close proximity to the St Leonards railway station and Crows Nest Metro station and town centre.

The site is located at 20-22 Atchison Street, St Leonards. The site has a primary frontage to Atchison Street to the south, Mitchell Street to the east and Atchison Lane to the north. The site is located within the North Sydney Local Government Area (LGA) and is located approximately 4.5km north of the Sydney CBD.

The site comprises two allotments described as Lot 1 in DP740017 and Lot 120 DP564606 with a total area of 1374.4sqm. The site is located near the crest of a high ridgeline point, with Mitchell Street falling in elevation towards the north of the site and Atchison Street falls towards the east. The site location is outlined in Figure 1.

Existing development on the site includes:

- 22 Atchison Street is currently occupied by six storey commercial office building and 18-20 Atchison Street comprises a three-storey commercial building which is currently vacant. The buildings were constructed in the 1980s and has a primary frontage to Atchison Street and secondary vehicular access from Atchison Lane.
- 22 Atchison Street accommodates additional vehicular access from Mitchell Street.

Figure 1 The Site



4 INCLUDED IN THIS REPORT

Enclosed is the Waste Management Plan for the proposed development at 20-22 Atchison Street, St Leonards. Included are details regarding:

- Land use;
- Waste generation;
- Waste systems;
- Bin quantity, size and colour;
- Collection frequency;
- Bin storage area;
- Signage;
- Waste collection;

- Responsibilities;
- Ventilation, washing and vermin-prevention;
- Noise reduction;
- DDA compliance;
- Supplier contact information; and
- Scaled waste management drawings.

5 LAND USE

Planning application number: SSD-87486461

Land Zone: MU1 Mixed Use Zone

Land use type: Shop-top housing

Number of levels: 40 (with 5 additional basement levels)

Residential Space: total of 181 apartments consisting of:

- 74 one-bedroom apartments;
- 85 two-bedroom apartments; and
- 22 three-bedroom apartments.

Commercial Space:

- 1,938m² commercial tenancies

6 DEMOLITION AND CONSTRUCTION WASTE RESPONSIBILITIES

This Waste Management Plan must be adhered to during the demolition, construction and ongoing management of the proposed development.

During site inductions for the construction and demolition phase, all contractors must be made aware of the waste management obligations, practices and legislative controls provided in this plan.

It is the responsibility of the appropriate Site Supervisor and relevant managing contractor that all waste disposal, load transfers and required assessments is adequately tracked and stored in a Waste Data File. Any associated receipt/invoices, waste classification documents and site validation certificates should be logged within this file accordingly.

All entries in the Waste Data File must include the following;

- Time and date;
- Description and size of waste;
- Waste facility used; and
- Vehicle registrations and company name.

Waste Data Files and relevant records may be requested during the construction stages for audit, inspection and quality management purposes.

6.1 WASTE CLASSIFICATION

All waste generated during the construction and demolition stages of the proposed development will be classified in accordance with *NSW EPA Waste Classification Guidelines 2014*.

Assessments should be routinely conducted of waste loads stored in skips or appropriate containers pre-disposal and off-site transfer to waste facilities, to ensure all materials can be accepted for disposal and recovery.

All waste classification assessments must follow the six-step procedure as outlined within the EPA waste classification guidelines stipulated above, with all waste classification data to be collected and recorded appropriately across the life of the development.

6.2 WASTE MANAGEMENT HIERARCHY

The NSW EPA waste management hierarchy has been adopted as the framework to guide the waste management practices of the proposed development, as depicted in Figure 2 below.

The waste hierarchy provides a reference on the order of approaches to achieve efficient resource use. The aspects of the hierarchy are applicable to the demolition and construction stages of this project. As a key objective for all employees and personnel, the avoidance of waste generation and reuse of materials will have priority over recycling, and recycling will have priority over disposal.

Figure 2 Waste Management Hierarchy

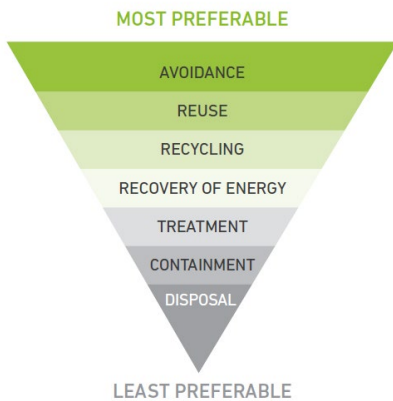

7 DEMOLITION AND CONSTRUCTION WASTE MANAGEMENT PLAN

7.1 DEMOLITION WASTE GENERATION AND MANAGEMENT PRACTICES

Generation rates applied to the demolition stages for the proposed development have been adopted from *The Hills Shire Council Development Control Plan* Appendix A (2012). The reference to the Hills Shire DCP is not based on its comparability as a suburb, but on the availability of specified construction and demolition waste rates. As North Sydney Council does not include such rates in its DCP, the rates from Hills Shire have been utilized to calculate the expected construction and demolition waste volumes for this project.

Based on a desktop assessment of the current site, it is noted that there is an existing six-storey commercial office building and a 3-storey commercial building located at 20-22 Atchison Street, St Leonards. Demolition waste from trees is factored into the rates provided below.

The demolition waste generation rates for Office Block per 1000m² have been adopted as these are found to be the most suitable rates for the existing site.

These generation rates are shown in Table 2.

Table 2 Waste Generation Rates for Demolition Materials

Building Material	Waste Quantity (tonnes per 1000m ²)
Concrete	7410
Bricks	1485
Timber / Gyprock	124
Steel	29
Others	155

The estimated demolition waste volumes for each material have been calculated based on the existing combined building footprint of 7,550m². The estimated volumes and management strategies for demolition waste are presented in Table 3 below.

The assessment below has been prepared to achieve the 80% recycling target for demolition waste that has been set by the NSW EPA *Waste Avoidance and Resource Recovery Strategy 2014-21*.

Table 3 Estimated Demolition Waste Generation Volumes and Management Options

Type of Waste Generated	NSW EPA Waste Classification	Most to Least Favorable			Specify method of onsite reuse, contractor and recycling outlet and /or waste depot to be used
		Reuse Estimate Volume Weight (t)	Recycle Estimate Volume Weight (t)	Disposal Estimate Volume Weight (t)	
Concrete	General Solid Waste (Non-Putrescible)		447.56t		All materials and waste types to be processed off site at a licensed facility that is approved to accept the material specified for further recycling and sorting. See Table 6 below for a comprehensive list of recycling and processing facilities located in proximity to the subject site.
Bricks	General Solid Waste (Non-Putrescible)		89.69t		
Timber / Gyprock	General Solid Waste (Non-Putrescible)		7.49t		
Steel	General Solid Waste (Non-Putrescible)		1.75t		
Other	Pre-classified General Solid Waste (Non- Putrescible)		9.36t		
Glass & Aluminium Windows	General Solid Waste (Non-Putrescible)		TBC*		
Floor Coverings	General Solid Waste (Non-Putrescible)		TBC*		
Fittings & Fixtures	General Solid Waste (Non-Putrescible)		TBC*		
Green Waste	General Solid Waste (Non-Putrescible)		TBC*		
General Waste	General Solid Waste (Non-Putrescible) Containing Putrescible Waste		TBC*		
Hazardous / special waste	Should hazardous materials be present within the current developments at the subject site, it must be disposed of in accordance with the appropriate guideline, refer to section (6) and Table 5 below for guidance				

Note: TBC* has been incorporated for totals of disposal/recyclable materials that will be determined once onsite works commence

7.2 CONSTRUCTION WASTE GENERATION AND MANAGEMENT PRACTICES

As discussed in Section 7.1 above, construction waste generation rates have been incorporated from *The Hills Shire Council Development Control Plan Appendix A (2012)*. The reference to the Hills Shire DCP is not based on its comparability as a suburb, but on the availability of specified construction and demolition waste rates. As North Sydney Council does not include such rates in its DCP, the rates from Hills Shire have been utilized to calculate the expected construction and demolition waste volumes for this project.

The construction waste generation rates for block of flats (per 1000m²) have been applied as these are found to be the most suitable rates corresponding to the proposed use and context of the subject site. These generation rates are shown in Table 4 below.

Table 4 Estimate Waste Generation Rates for Construction Materials

Building Material	Waste Quantity (tonnes per 1000m ²)
Timber	0.70
Concrete	6.70
Bricks	3.20
Gyprock	1.30
Metal	1.30
Other	0.60

The estimated construction waste volumes for each material have been calculated based on an estimated construction development footprint and an area of 18,547m². The estimated volumes and management strategies for construction waste are presented in Table 5.

The assessment below has been prepared to achieve the 80% recycling target for demolition waste that has been set by the NSW EPA *Waste Avoidance and Resource Recovery Strategy 2014-21*. All recycling and diversion targets will be revised by the Site Supervisor during the construction works, as other waste streams (i.e. general waste) would need to be accounted for during both demolition and construction stages.

Table 5 Estimated Construction Waste Generation Volumes and Management Options

Type of Waste Generated	NSW EPA Waste Classification	Most to Least Favorable			Specify method of onsite reuse, contractor and recycling outlet and /or waste depot to be used
		Reuse Estimate Volume Weight (t)	Recycle Estimate Volume Weight (t)	Disposal Estimate Volume Weight (t)	
Timber	General Solid Waste (Non-Putrescible)		0.10t		All materials and waste types to be stored and separated where possible. All generated waste(s) to be processed off site at a licensed facility that is approved to accept the material specified for further recycling and sorting. See Table 6 below for a comprehensive list of recycling and processing facilities located in proximity to the subject site.
Concrete	General Solid Waste (Non-Putrescible)		0.99t		
Bricks	General Solid Waste (Non-Putrescible)		0.47t		
Gyprock	General Solid Waste (Non-Putrescible)		0.19t		
Metal	General Solid Waste (Non-Putrescible)		0.19t		
General waste (including residual waste and dust)	General Solid Waste (Non-Putrescible) Containing Putrescible Waste		TBC*		
Other	Pre-classified General Solid Waste (Non- Putrescible)		0.09t		

Note: TBC* has been incorporated for totals of disposal/recyclable materials that will be determined once onsite works commence

7.3 WASTE STORAGE AND COLLECTION REQUIREMENTS

Demolition and construction waste generated during the development of the site will be separated and recycled where possible. All recyclable material will be separated and stored onsite in skip bins or via an appropriate waste container.

Waste bays and storage areas will be located in the same area where demolition and construction practices are conducted.

Demolition and construction waste shall not be stored along footpaths, public reserves and street gutters or in areas that would lead to contamination of stormwater and waterways.

In the circumstance an appropriate waste container cannot be supplied, due to timing of waste transfers and capacity limits at facilities, all demolition and construction wastes must be stored within the site boundary and must consider the factors mentioned above, to avoid the potential contamination of soil and stormwater flows.

The position of the designated waste bays onsite may change according to building works and the progression of the development. Access, visual amenity and work health and safety (WHS) requirements should always apply to the selection of waste storage area locations.

All waste storage areas onsite should:

- Be located in accessible areas for on-site movement, transfers and collection;
- Have an appropriate space allocated for the quantity of waste generated and separation of recyclable materials;
- Have space allowances for required on-site treatment facilities, such as compaction equipment if required;
- Have an acceptable level of weather protection and be enclosed if necessary;
- Be secured and lockable;
- Be well-ventilated and located nearby a sewer for drainage purposes; and
- Provided clear signage and labelling to ensure appropriate use.

7.4 BIN TYPE, QUANTITY AND DIMENSIONS

An appropriate size and number of waste containers should be provided for purpose of source separating each type of demolition and construction material generated on site. This is a standard to maximise the recovery of materials, while reducing the costs and diversion of waste disposed at landfill.

For the context of this development waste skips should be provided for the following

- 1 or more general waste skip for products including sand and soil not classified as VENM, gyprock, treated timber, residual waste and dust, to be delivered to BINGO Recycling Centre, Artarmon: 1300 424 646;
- Recycling skips with one skip per material type for bricks, sandstone and concrete to be delivered to BINGO Recycling Centre, Artarmon: 1300 424 646;
- 1 recycling skip for clean metal to be delivered to BINGO Recycling Centre, Artarmon: 1300 424 646;
- 1 organics waste skip for untreated timber and VENM that is not reused on site including garden vegetation and untreated timber, to be delivered to BINGO Recycling Centre, Artarmon: 1300 424 646;
- Additional recycling skips, as required for paper & cardboard, glass, plastics and others to be delivered to BINGO Recycling Centre, Artarmon: 1300 424 646 or a suitable recycling facility.

Note: refer to section 9 below for a detailed directory relevant to the disposal of demolition and construction for the subject site.

The size of waste containers and skip bins should be appropriate to the nature of waste generated, site constraints and the available storage area. The following options shown in Figure 3 below would be acceptable:

Figure 3 Skip Bin Size Dimensions

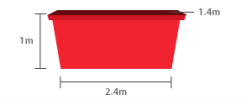
Bin Sizes	Wheelie Bins	6x4 Box Trailers
 <p>10m³ 4.5m long 1.7m wide 1.5m high</p>	x 40	x 10
 <p>6m³ 3.2m long 1.4m wide 1.5m high</p>	x 24	x 6
 <p>4m³ 2.8m long 1.4 wide 1 high</p>	x 16	x 4
 <p>3m³ 2.4m long 1.4 wide 1m high</p>	x 12	x 3
 <p>2m³ 1.8m long 1.4 wide 1m high</p>	x 8	x 2

7.5 WASTE SIGNAGE AND SAFETY

As a standard, signage should be applied in all waste storage areas, with waste containers to be appropriately labelled and colour coded to identify the correct waste type to be disposed into each bin.

All signage installed should use EPA standards as a reference shown in Figure 4 below. All skip bins should be clearly visible, provided safe paths of travel and must not be overfilled to prevent the risk of injury and relevant environmental impacts.

Figure 4 NSW EPA Signage

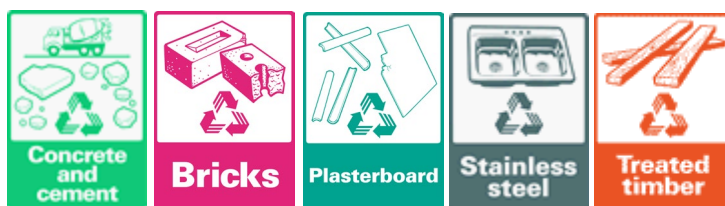

8 CONSTRUCTION AND DEMOLITION SITE MANAGEMENT

8.1 ASBESTOS, AND OTHER HAZARDOUS/CONTAMINATED WASTE

The construction and demolition phases of the development may involve the removal of contaminated/hazardous materials including asbestos. All hazardous/contaminated materials will be removed by qualified contractors and disposed at licensed facilities.

All hazardous/contaminated waste removal, transport and disposal must comply with the requirements found in the SafeWork NSW Code of Practice, EPA guidelines and North Sydney Council requirements located here: <https://www.northsydney.nsw.gov.au/homepage/64/az-waste-and-recycling> if applicable.

Any disposal and off-site transfer of classified hazardous waste and contaminated materials must be recorded in the Waste Data File and or tracked in accordance with Part 4 of the *Protection of the Environment Operations (Waste) Regulation 2014*.

If hazardous waste and contaminated materials are located on-site during the stages of demolition, excavation, and construction, the Site Supervisor is to immediately stop all works and contact a qualified hazardous/contaminated waste contractor prior continuing all on-site works.

The following mitigation measures will apply in the event hazardous and contaminated waste is uncovered:

- Storing (if required) and covering contaminated materials with an industrial approved and graded HDPE liner and placed in an area that is protected from severe weather events;
- Segregating all classified hazardous and contaminated waste from general waste, recycling, and other specified skip bin areas;
- Ensuring vehicles are securely covered when transporting and loading contaminated materials to prevent windblown emissions and potential spillage; and
- Decontamination of equipment and containers that have stored hazardous materials to prevent the spread of contamination.

8.2 LIQUID WASTE MANAGEMENT AND HANDLING

All liquid waste located and classified onsite during the construction and demolition stages of the proposed development must be handled appropriately in accordance with NSW EPA guidelines that include *Hazardous Waste Storage and Processing: Guidance for the Liquid Waste Industry 2016*.

In the event that liquid waste is identified and present (e.g. in the form of spills) it is the responsibility of the Site Supervisor and relevant managers to provide an immediate response to prevent any necessary environmental impacts.

The following actions in such circumstances should include:

- Containing the identified spill/liquid waste distribution area;
- Reporting all incidents directly to relevant authorities;
- Logging incidents internally to assist with conducting any onsite investigations; and
- Introducing precautionary actions to lessen the risk of similar incidents occurring in the future.

If the management and handling of liquid waste is part of regular practice to complete the demolition and construction stages of the proposed site. It is the responsibility of the managing contractor adheres to the EPA guidelines and best practice standards regarding storage, segregation, disposal and routine monitoring.

8.3 LITTER MANAGEMENT AND STORMWATER POLLUTION PREVENTION

All staff and relevant managers employed in the demolition and construction stages must be aware of the practices applied to mitigate the potential litter and stormwater pollution that can occur through on-site works.

The Site Supervisor and or an appointed staff would be responsible in ensuring the following to mitigate the dispersion of litter and stormwater pollution on site:

- Establishing appropriate barriers and fencing to trap coarse sediment at points where stormwater can flow and run-off into gutters, drains and waterways;
- Ensuring adjacent streets and gutters are regularly swept and not hosed. Relocating and removing accidental spills of soil and other material immediately;
- Maintaining kerbside vegetation in a healthy state and not using nature strips or footpaths for parking or stockpiling waste. If unavoidable contact the relevant council for permission;
- Ensuring wash water and waste concrete, paint and other solutions used on site is contained within the site boundary. The same is to be applied when cleaning equipment;
- Covering any appropriate waste containers and skip bins after daily onsite works to minimize windblown litter and to protect waste storage area during the event of inclement weather;
- Ensuring all waste loads transported off-site is kept enclosed to avoid airborne litter being generated;

8.4 TRAINING

All staff, managers, and appropriate supervisors employed during the stages of construction and demolition must be made aware of and be provided formal training on the site-specific waste management procedures of the proposed development.

As a standard, toolbox and pre-start meetings will be undertaken as a part of general site induction and will be refreshed periodically. Training and induction material provided should contain the following:

- Legal obligations and guidelines;
- Emergency management and response procedures;
- Waste storage areas and specific containers used for waste separation;
- Litter prevention practices on and off site;
- Applicable waste reduction and avoidance practices;
- Hazardous/contaminated waste management response;
- Environmental and legislative implications of poor waste management behaviors; and
- Responsibility, duties and reporting lines outlined (including appointing personnel responsible for waste management and individual responsibilities)

8.5 MONITORING AND COMPLIANCE

All relevant documents relating to volumes of waste disposed and transferred to the appropriate facility are to be maintained. Any dockets verifying recycling/disposal, waste testing/assessment reports, validation certificates must be adequately stored and presented to the EPA and relevant Council when required.

Inspections of waste storage areas should be routinely conducted. An inspection log and checklist are to be maintained for reporting purposes. Inspections will be used to identify and correct issues waste management practices onsite.

Audits are to be performed by the relevant demolition and construction contractor to monitor the effectiveness of recycling/reuse initiatives and waste separation practices. Audits that indicate procedures and compliance not met as mentioned within the waste management plan should be rectified immediately, through the provision of additional staff training or adjustment to waste signage.

All environmental incidents require an immediate response to minimise the potential impacts. An incident register must be maintained across demolition and construction stages and should include the contact details of the 24-hour NSW EPA response unit.

9 BIN SUPPLIER AND RECYCLING DIRECTORY

Table 6 below provides an overview and list of appropriate landfill and resource recovery centers based on the common types and classifications of waste generated from the life of the project. The managerial contractor for required construction works is not obligated to procure goods/services from these companies. This is not, nor is it intended to be, a complete list of available suppliers. SALT does not warrant (or make representations for) the goods/services provided by these suppliers.

Materials removed from the proposed site will need to be managed within the provisions of current legislation and may include segregation by material type classification in accordance with NSW EPA (2014) Waste Classification Guidelines, Part 1: Classifying Waste, as mentioned above. With disposal at facilities appropriately licensed to receive the classified waste materials.

Please note: the nominated facilities provided below are suitably located, licensed facilities capable of accepting the relevant waste materials. Alternative sites may be utilised if preferred. However, alternative facilities and waste-transfer providers must be licensed to receive the generated waste materials.

The capacity of nominated facilities in accepting the specified volume of waste materials, may differ upon the time construction commences. It is recommended that the proposed facilities are contacted prior to the transfer of waste off-site.

Table 6 Bin Supplier and Recycling Directory

Waste Type	Business Name	Contact Information	Suburb	State
Asbestos (less than 10m ²)	Cleanaway	02 8645 4304	Artarmon	NSW
	BINGO Industries	1300 424 646	Artarmon	NSW
Asbestos (Greater than 10m ²)	Sydney Asbestos	1300 033 483	Sylvania	NSW
	Asbestos Removal Sydney	1300 119 233	Mortdale	NSW
Excavation Material				
Bricks				
Concrete				
Metals	Cleanaway	02 8645 4304	Artarmon	NSW
	Bingo Industries	1300 424 646	Artarmon	NSW
Plasterboard				
Tiles				
Timber				

Note: Waste generated outside the site must not be received for onsite storage and or the transportation to the permitted facilities listed above.

10 RESIDENTIAL WASTE MANAGEMENT PLAN

10.1 WASTE GENERATION

Residential waste generation rates are shown below in Table 7. Calculations are based on a 7 day per week operation.

Generation rates have been adopted based on residential waste generation rates enclosed in the North Sydney Council's *Development Control Plan 2013*. These rates are considered appropriate for a shop-top housing development located within the North Sydney Council.

Any common spaces to the residential areas, including lobbies, gym and amenities have not been included in these calculations as any waste generated in these areas is generated in service of the residential dwellings and therefore incorporated into the below rates.

Table 7 Waste Generation Rates

Dwelling Size	Garbage (L/3 units/week)	Commingled Recycling (L/15 units/week)
12+ Units	240	480

A waste generation assessment of the proposed development is provided in Table 8.

Table 8 Waste Generation Assessment

Dwelling Type	Quantity	Waste Per Week (L/Week)	
		Garbage	Recycling
Apartment	181	14,480	5,792
Total Waste Generated per Week		14,480L	5,792L

10.2 WASTE SYSTEMS

Waste would be sorted on-site by residents as appropriate into the following streams:

- Garbage (General Waste);
- Commingled Recycling;
- Organics; and
- Bulky waste.

10.2.1 DUAL CHUTE

All residents would dispose of bagged garbage and loose recyclables using the provided dual chute system. There would be one chute dedicated to garbage and another dedicated to commingled recycling. Chute doors would be signed as "Garbage" or "Commingled Recycling" as appropriate. Each chute would output directly into the stream appropriate 1,100L bin within the lower ground level chute room. The garbage chute will be fitted with a built-in compactor that compresses waste at a 2:1 ratio.

Please note that the maximum deflection angle typically allowed for the chute system is 22°. It is however recommended that a smaller angle than the maximum is adopted to prevent clogging of materials within the chute system.

It is recommended that a spare bin be purchased and placed under the chutes for use during bin collections.

Termination of chutes would have skirting or other equivalent system to reduce any materials leaving the bin on impact.

Chute termination points would be fenced off, so residents are not able to access the equipment.

It is recommended that waste bins have reinforced bases for bin longevity.

10.2.2 GARBAGE (GENERAL WASTE)

Each dwelling would be furnished with plastic lined bins to have a minimum capacity of 20 litres for the temporary holding of garbage. Residents would transfer the waste as required to the appropriate chute drop off point at each residential level, as shown in Appendix 1.

Building management is responsible for placing empty bins beneath garbage chute dispensing point.

Garbage is to be disposed of bagged.

10.2.3 COMMINGLED RECYCLING

Each dwelling would be furnished with unlined bins to have a minimum capacity of 20 litres for the temporary holding of commingled recyclables. Residents would transfer recyclables as required to the appropriate chute drop off point at each residential level, as shown in Appendix 1.

Building management is responsible for placing empty bins beneath recycling chute dispensing point.

Commingled recyclables are to be disposed of loosely.

10.2.4 ORGANICS

Each dwelling would be furnished with unlined bins or bins lined with compostable lining approved by the waste contractor, to have a minimum capacity of 5 litres. Residents would transfer organics waste as required to the organics bins positioned beside the chute drop off point at each residential level.

Organics waste is to be disposed of loosely or in compostable bags that have been approved by the waste contractor. These compostable bags should be marked with the Australian Standard compostable logo as shown in Figure 5 below. It should be noted that non-compostable bags should not be placed into the organics bins as it cannot be composted and thus will affect the quality of the organic product.

Figure 5 Australian Standard Compostable Logo



10.2.5 BULKY WASTE

A separate bulky waste storage room of 39m² has been allocated beside the residential bin room located within lower ground level.

Residents would access this room via the lift.

Building management would arrange bulky waste collections with collections to be conducted by Council or a private waste collection contractor.

10.3 BIN QUANTITY, SIZE AND COLLECTION FREQUENCY

Table 9 and Table 10 below contain information regarding bin quantity, size and frequency of collection.

Table 9 Bin Size and Collection Frequency

Waste Stream	Collections per Week	Bin Size	No. Bins	Weekly Capacity	Weekly Volume
Garbage	1	1,100L	7	7,700L	14,480L (7,240L- compacted)
Commingled Recycling	1	1,100L	6	6,600L	5,792L
Organics	1	120L	38 (1 bin on each)	4,560L	-

	residential level)	
Bulky Waste	39m ² bulky waste storage room (collected as required)	-

Table 10 Typical Waste Bin Dimensions

Capacity (L)	Width (mm)	Depth (mm)	Height (mm)	Area (m ²)
1,100	1240	1070	1330	1.33
120	480	545	930	0.26

Note: The above dimensions are based on SULO's flat lid bin specifications

10.4 BIN COLOUR AND SUPPLIER

All bins would be provided by Council. The below bin colours are specified by North Sydney Council:

- Garbage (general waste) bins would have red lids with dark green body;
- Recycling bins would have yellow lids with dark green body; and
- Organics bins would have green lids with dark green body.

10.5 WASTE STORAGE AREA

Table 11 demonstrates the cumulative space requirements and provision of waste areas in the residential areas of the proposed development.

Please refer to scaled drawing shown in Appendix 1.

Table 11 Waste Area Space Requirements

Stream	Space Required (excluding circulation)	Space Provided
General Waste	9.31m ²	66.00m ²
Commingled Recycling	7.98m ²	
Organics	9.88m ²	
TOTAL	27.17m²	66.00m²

Note: A separate storage room of 39 m² is allocated for bulky waste.

Note, commercial and residential waste would not be stored together.

Waste management would be overseen by building management.

10.6 WASTE COLLECTION

Waste would be collected by North Sydney Council as follows:

- 7 x 1,100L garbage bins collected weekly;
- 6 x 1,100L commingled recycling bins collected weekly;
- 38 x 120L organics bins collected weekly; and
- 39m² area allocated for bulky waste (collected as-required).

All waste bins would be stored on-site in the residential bin room provided on the lower ground level.

General waste collections would occur via Council's 10.5m long waste collection vehicle.

Bulky waste collections would be performed by a utility vehicle or AustRoads B99 design vehicle equivalent or by a Council hard waste collection vehicle.

Waste collection vehicles would stop safely at the dedicated waste loading dock.

Vehicle operators would ferry waste bins from the residential bin holding room and return upon emptying.

Waste collection vehicles would exit the loading dock in a forward direction, exiting the subject site onto Atchison Lane.

Please refer to the swept path analysis attached in APPENDIX 2 which demonstrates safe access by the waste collection vehicle.

It is noted that due to service infrastructure (substation, fire tanks, fire pumps and controls) required to be located along the northern façade of the building, there is no option to locate the bin store at the northern end of the building adjacent to Atchison Lane. For this reason, a bin holding area for collection from the lane is not feasible. Therefore, to enable Council collection of residential waste, a loading area within the ground level of the building has been provided with sufficient turning space for vehicles up to 10.5m long.

The use of the loading area by Council waste vehicles is infrequent (once per week).

Building management would ensure that council waste vehicle operators are able to access the bin room.

11 COMMERCIAL WASTE MANAGEMENT PLAN

11.1 WASTE GENERATION

Commercial waste generation rates are shown in Table 12. Calculations are based on 7 days per week operation for the commercial tenancies within the development.

Generation rates have been adopted based on commercial waste generation rates enclosed in the North Sydney Council's *Development Control Plan 2013*. These rates are considered appropriate for the commercial components of the development located within the North Sydney Council.

It is assumed that 20% of general waste will consist of organics waste. General waste streams have been adjusted by 20% to reflect the separation of organics.

Waste generation rates for paper/cardboard in offices and retail tenancies have been calculated based on NSW EPA Reducing Business Waste: Industry Fact Sheet (2012) which states that mixed recycling streams for commercial and industrial sites have a general composition of 30% of cardboard and paper material. Commingled recycling streams have been adjusted by 30% to reflect the separation of paper/cardboard.

Any common spaces to the commercial areas including lobbies and amenities have not been included in these calculations as any waste generated in these areas is generated in service of the commercial areas and therefore incorporated into the below rates.

Table 12 Waste Generation Rates

Use	Garbage	Organics	Commingled Recycling	Paper/Cardboard
Commercial Offices	8 L/100m ² /day	2 L/100m ² /day	7 L/100m ² /day	3 L/100m ² /day

A commercial waste generation assessment is provided in Table 13.

Table 13 Waste Generation Assessment

Use	Area (m ²)	Operational days	Waste Per Week (L/Week)			
			Garbage	Organics	Recycling	Paper/Cardboard
Commercial	1,938	7	1,085	271	950	407
Total Waste Generated per Week			1,085L	271L	950L	407L

11.2 WASTE SYSTEMS

Waste would be sorted on-site by staff and cleaners as appropriate into the following streams:

- Garbage (General Waste);
- Organics;

- Commingled Recycling;
- Paper/Cardboard; and
- Bulky Waste

11.2.1 GARBAGE (GENERAL WASTE)

The office spaces would be furnished with plastic lined bins for the temporary holding of garbage waste, to have minimum cumulative capacity of 10 litres per 100m² of floor area. This capacity is based on the transfer of waste to the bin room occurring once per day.

Staff/cleaners would dispose of waste from these bins directly into the appropriate 1,100L bins provided within the lower ground level commercial bin room (refer to Appendix 1).

Garbage is to be disposed of bagged.

11.2.2 COMMINGLED RECYCLING

The office spaces would be furnished with plastic lined bins for the temporary holding of commingled recyclables, to have minimum cumulative capacity of 10 litres per 100m² of floor area. This capacity is based on the transfer of recycling to the bin room occurring once per day.

Staff/cleaners would dispose of waste from these bins directly into the appropriate 1,100L bin provided within the lower ground level commercial bin room (refer to Appendix 1).

Commingled recyclables would be disposed of loosely.

11.2.3 ORGANICS

The office spaces would be furnished with unlined bins for the temporary holding of organics waste, to have minimum cumulative capacity of 5 litres per 100m² of floor area. This capacity is based on the transfer of waste to the bin room occurring once per day.

Staff/cleaners would dispose of waste from these bins directly into the appropriate 240L bins provided within the lower ground level commercial bin room (refer to Appendix 1).

Organics waste is to be disposed of loosely or in compostable bags that have been approved by the waste contractor.

These compostable bags should be marked with the Australian Standard compostable logo as shown in Figure 6 below. It should be noted that non-compostable bags should not be placed into the organics bins as it cannot be composted and thus will affect the quality of the organic product.

Figure 6 Australian Standard Compostable Logo



11.2.4 PAPER/CARDBOARD RECYCLING

The office spaces would be furnished with plastic lined bins for the temporary holding of paper/cardboard, to have minimum cumulative capacity of 5 litres per 100m² of floor area. This capacity is based on the transfer of paper/cardboard to the bin room occurring once per day.

Staff/cleaners would dispose of waste from these bins directly into the appropriate 1,100L bin provided within the lower ground level commercial bin room (refer to Appendix 1).

Paper/Cardboard would be disposed of loosely.

11.2.5 BULKY WASTE

Bulky waste storage space of 2m² has been allocated within the commercial bin room located within lower ground level.

Cleaners would access this room via the lift.

Building management would arrange bulky waste collections with collections to be conducted by a private waste collection contractor.

11.3 BIN QUANTITY, SIZE AND COLLECTION FREQUENCY

The bin quantity, size and the frequency of collection are shown below in Table 14 and Table 15.

Commercial waste collections would be coordinated with residential waste collections to reduce truck movements in the local area.

Table 14 Bin Size and Collection Frequency

Waste Stream	Collections per Week	Bin Size	No. Bins	Weekly Capacity	Weekly Volume
Garbage	1	1,100L	1	1,100L	1,085L
Organics	1	240L	2	480L	271L
Recycling	1	1,100L	1	1,100L	950L
Paper/Cardboard	1	1,100L	1	1,100L	407L
Bulky Waste	2m ² storage space for bulky waste (collected as required)				-

Table 15 Typical Waste Bin Dimensions

Capacity (L)	Width (mm)	Depth (mm)	Height (mm)	Area (m ²)
1,100	1240	1070	1330	1.33
240	585	730	1060	0.43

Note: The above dimensions are based on SULO's flat lid bin specifications

11.4 BIN COLOUR AND SUPPLIER

All bins would be provided by private supplier. The below bin colours are specified by Australian Standard AS4123.7-2006, however due to the private nature of the collection, these are only recommendations and are not mandatory:

- Garbage (general waste) shall have red lids with dark green or black body;
- Recycle shall have yellow lids with dark green or black body;
- Organics shall have green lids with dark green or black body; and
- Paper/Cardboard shall have blue lids with dark green or black body.

Note, private contractors often supply bins for collection.

11.5 WASTE STORAGE AREA

Table 16 demonstrates the cumulative space requirements and provision of waste areas in the commercial areas of the proposed development.

Please refer to scaled drawing shown in Appendix 1.

Table 16 Waste Area Space Requirements

Stream	Space Required (excluding circulation)	Space Provided
General Waste	1.33m ²	46.00m ²
Commingled Recycling	1.33m ²	
Organics	0.86m ²	
Paper/Cardboard	1.33m ²	
Bulky Waste	2.00m ²	
TOTAL	6.85m²	46.00m²

Note, commercial and residential waste would not be stored together in the ground level bin room.

Waste management would be overseen by building management.

11.6 WASTE COLLECTION

Commercial waste would be collected by private contractor as follows:

- 1 x 1,100L garbage bins collected once per week;
- 1 x 1,100L commingled recycling bin collected once per week;
- 2 x 240L organics bins collected once per week;
- 1 x 1,100L paper/cardboard bin collected once per week; and
- 2m² storage area allocated for bulky waste (collected as-required).

All waste bins would be stored on-site in the bin room provided on the lower ground level commercial bin room.

Waste collections would occur between 7am to 8pm on Mondays to Fridays and between 8am to 8pm on Saturdays, Sundays and public holidays, in accordance with EPA NSW *Protection of the Environment Operations (Noise Control) Regulation 2017*. This is to ensure minimal noise impacts to the neighboring properties.

General waste collections would occur via an 8.8m medium rigid vehicle.

Bulky waste collections would be performed by a utility vehicle or AustRoads B99 design vehicle equivalent.

Building Management is responsible for coordinating commercial waste collection to ensure it does not coincide with residential waste collection.

Waste collection vehicles would stop safely at the lower ground level waste loading dock.

Vehicle operators would ferry waste bins from the commercial bin room and return upon emptying.

Waste collection vehicles would exit the loading dock in a forward direction, exiting the subject site onto Atchison Lane.

Please refer to the swept path analysis attached in APPENDIX 2 which demonstrates access by the waste collection vehicle.

Building management would ensure that waste vehicle operators are able to access the commercial bin room.

Commercial waste bins would not be presented to street kerb at any point.

12 RESPONSIBILITIES

Building management would be responsible for overseeing waste management within the development. Responsibilities would include:

- Providing a copy of the endorsed Waste Management Plan to the building operator;

- All signages and waste education materials should be based on the latest information provided from the NSW EPA guidelines and standards for recycling, made available here for reference: <https://www.epa.nsw.gov.au/your-environment/recycling-and-reuse/business-government-recycling/standard-recycling-signs>
- Providing residents and commercial tenants with an information package which would include the following information:
 - (a) A copy of this Waste Management Plan which includes information on waste storage areas and management methods onsite;
 - (b) Methods and techniques for waste reduction and minimisation (i.e. having better purchasing practices of food, avoiding single use items where possible, utilising reusable bags and containers etc.);
 - (c) Information regarding bin collection days and requirements;
 - (d) Staff members' responsibilities with regard to bin usage, storage, and collection
- Rotating bins placed beneath chutes or providing staff/cleaners with a cleaning and bin transfer/rotation schedules;
- Ensure that all bins throughout the site and the bin room are equipped with appropriate signages to guide users on appropriate segregation methods for their waste and recyclables;
- Inspecting waste stores;
- Reviewing contamination within bins; and
- Investigating incidents of inappropriate waste storage (or aggregation).

Building management would ensure anyone found responsible for inappropriate waste disposal would be appropriately educated and made aware of correct waste disposal techniques.

It is recommended that building management conducts a waste audit if waste is found to be inappropriately deposited by users or if the bin capacities need to be reviewed.

13 SIGNAGE

Waste storage areas and bins would be clearly marked and signed with the industry standard signage approved by NSW EPA or equivalent. The typical NSW EPA signage is illustrated in Figure 7.

Figure 7 NSW EPA Signage



Signage within the waste disposal areas should inform staff members on the significance of food waste separation and highlight the end use products that can be generated from the composting process. The signage should also note that any contamination within the food organic bins would affect the quality of the product and thus cause the separation to be ineffective. This may increase their awareness and encourage them to separate food waste while also minimising contamination within the food organic bins. This signage may be available from the waste collection contractor.

14 SUSTAINABILITY ACTION PLAN AND INITIATIVES

The importance of restructuring the institutional waste management methods in developments is becoming more apparent as we experience the adverse impacts of increasing waste volumes and declining recycling rates.

Developments such as the proposed subject site can contribute towards the prevention and reduction of nationwide waste generation volumes as well as to promote a local circular economy system.

Building management should encourage users by demonstrating a commitment towards waste avoidance and minimisation initiatives. The waste hierarchy as detailed in the *Environmental Protection Act 2017* should be observed in order of preference (refer to Figure 2 above).

In addition to the waste management strategy detailed in the enclosed report, building management can establish landfill diversion and recycling targets and conduct periodic waste audits to monitor contamination levels in recycling bins. The results of the audit could be shared with residents to encourage them to continue or to improve their waste separation efforts. The audit may also be beneficial from a cost perspective as it would inform building management of opportunities to reduce bin numbers or collection frequencies.

15 WASTE AREA DESIGN REQUIREMENTS

15.1 VENTILATION

Ventilation would be provided in accordance with Australian Standard AS1668. Rooftop exhaust fans would be implemented within each chute system to ensure proper chute ventilation is provided.

The waste room will be equipped with tight fitting doors and impervious flooring. Any openings within the waste room will be fitted with vermin-proof mesh.

15.2 LITTER MANAGEMENT, WASHING AND STORMWATER POLLUTION PREVENTION

Chutes would be equipped with flushing nozzles to enable the regular washing of chutes to maintain appropriate hygiene levels for future use.

An appropriately drained wash down area would be provided within the bin room in which each bin is to be washed regularly by building management. Bin washing areas or bin wash bays must discharge to a litter trap and/or grease trap. Bin wash areas should not discharge into stormwater drainage.

Alternatively, a third-party bin washing service can be engaged to perform this service. Bin washing suppliers must retain all waste water to within their washing apparatus so as to not impact on the drainage provisions of the site.

Building management and cleaners would be responsible in ensuring the following to prevent or minimise the dispersion of litter throughout the site:

- Prevent overfilling of bins by ensuring bin lids are closed at all times;
- Require waste contractor to remove any spillage that may occur during waste collections; and
- Ensure anyone found responsible for inappropriate waste disposal or dumping would be appropriately educated and made aware of correct waste disposal techniques.

15.3 NOISE REDUCTION

The chute system and waste areas would meet EPA, BCA and AS2107 acoustic requirements as appropriate within operational hours assigned to minimise acoustic impact on surrounding premises.

Waste collection timings in accordance with EPA NSW *Protection of the Environment Operations (Noise Control) Regulation 2017* have been stipulated in the waste collection section above.

Waste contractors should also abide by the following regulations to ensure minimal noise impacts to the neighboring properties:

- Compaction only to be carried while on the move;
- Bottles should not be broken up at the point of collection
- Routes that service entirely residential areas should be altered to reduce early morning disturbances; and
- Noisy verbal communication between operators should be avoided where possible.

15.4 DDA COMPLIANCE

All waste areas to be accessed by commercial staff/residents would comply with AS1428.1:2009.

16 RISK AND HAZARD ANALYSIS

Table 17 shows the potential risks, severity and suggested control methods that could be considered to avoid the risks from occurring during waste collections.

Note that this is a preliminary risk assessment and does not replace the need for the building management and collection contractors to complete their respective OHS assessment for waste collections.

The information provided below have been adopted from WorkCover NSW *Collection of Domestic Waste: Code of Practice*. The severity of each risk has been determined based on the risk rating table enclosed in Department of the Environment *Environmental Management Plan Guidelines* 2014.

Table 17 Potential Risks and Control Methods During Waste Collections

Area	Risk	Severity	Suggested controls
Waste collection	Incidents during waste collection vehicle ingress or egress movements	Low	<p>Vehicle operators would be trained in ensuring the following</p> <ul style="list-style-type: none"> Tailgate is closed after clearing waste area Move vehicle slowly when tailgate or body is raised Clear waste from tailgate seal and from rear of machine before departure from the subject site Ensure tailgate is locked after unloading operation Vehicle operators should not exit the vehicle body unless engine is switched off, ignition key is removed, safety prop is in position and the vehicle body is well ventilated. Regular safety checks and inspection of vehicles should be conducted.
	Incidents during manual handling of bins	High	Vehicle should meet relevant Australian Design Rules. Ensure that vehicles with low bowl height are used to avoid lifting of bins above shoulder height. Vehicle operator should be clear of the equipment before activation of packing or tipping controls.
	Slip and trip hazards in moving into and out of the vehicle	Medium	Maintain sufficient and frequent communication between driver and runner. The hose should not be used as handholds when mounting or dismounting.
	Slips and trips while transporting bins	Low	<p>As the car parking area is at the same grade with that of the waste storage area, there are no hazards presented from the presence of slopes or steps. The car parking and waste storage area would also be well lit at all times to ensure good visibility to staff/vehicle operators.</p> <p>However, to ensure that any other potential risks are mitigated, frequent communication should be maintained between the driver and runner and the runner should only transfer one bin at a time.</p>
Surrounding traffic	Conflict with other vehicle operators and residents within the car park during collection	Medium	<p>Frequency of use is low (i.e. once per week for residential bin collection).</p> <p>Ensure that collection occurs only at off-peak hours.</p> <p>The collection area should also be well-lit to allow for better visibility of oncoming traffic and pedestrians.</p> <p>Loading management plan to be prepared.</p>
Waste bins	Type of wastes handled – risk associated in contact with unknown hazardous substances or sharp objects	Medium	<p>Residents and commercial tenants should be educated on safe disposal of hazardous substances and sharp objects.</p> <p>Waste vehicle operators should be trained and informed on safe handling of unknown substances. Operators could be provided with PPE to avoid infections and to assist in handling of waste bins.</p>
Waste Bins	Overflowing bins affecting the transport of bins to the waste collection vehicle or presenting as a trip hazard.	Low	The recommended number of bins enclosed in this WMP provides a larger capacity than the volume generated for all waste streams hence there would be a low likelihood of this occurring.



17 SUPPLIER CONTACT INFORMATION

Table 18 and Table 19 provide a list of equipment specified by this waste management plan.

Below is a complimentary listing of contractors and equipment suppliers. You are not obligated to procure goods/services from these companies. This is not, nor is it intended to be, a complete list of available suppliers.

SALT does not warrant (or make representations for) the goods/services provided by these suppliers.

Table 18 High Level Purchasing Schedule (Residential Bin Room)

Item	Quantity	Supplier	Notes
1,100L Bins	13	Council	7 x 1,100L garbage bins 6 x 1,100L commingled recycling bins
1,100L Bins	2	Private Supplier	1 x 1,100L spare general waste bin (beneath chute dispensing point) 1 x 1,100L spare recycling bin (beneath chute dispensing point)
120L Bin	38	Council	38 x 120L organics bins
Dual Chute System	1 (2 Chutes)	Private Supplier	1 x Dual Chute System

Table 19 High Level Purchasing Schedule (Commercial Bin Room)

Item	Quantity	Supplier	Notes
1,100L Bins	6	Private Supplier	4 x 1,100L garbage bins 1 x 1,100L commingled recycling bin 1 x 1,100L paper/cardboard bin
240L Bins	4		4 x 240L organics bins

17.1 EQUIPMENT SUPPLIERS

17.1.1 DUAL CHUTE SYSTEM

- Wastech Engineering – 03 8787 1600
- Elephant's Foot – 02 9780 3500
- Australian Chutes & Engineering – 03 9761 7557

17.1.2 BIN SUPPLIER

- Sulo MGB Australia (wheelie bin) – 1300 364 388
- Source Separation System (wheelie bin and bin stations) – 1300 739 913

17.2 WASTE COLLECTION CONTRACTORS

17.2.1 GARBAGE, RECYCLING AND ORGANICS

- North Sydney Council (residential waste collections) – (02) 9936 8100
- Cleanaway – 13 13 39
- JR Richards – 0 6762 0982
- Roger Waste Services – (02) 6769 1609
- Bingo Industries – 1300 424 646
- Veolia Environmental Services – 132 955
- Fortress Recycling – 0 00 731 3400

17.3 BIN WASHING SERVICES

- Tamworth Wheelie Bin Cleaners – 02 6762 7111

18 PURPOSE AND LIMITATIONS

This Waste Management Plan has been prepared to form a part of the SSDA application. The report is prepared to:

- Demonstrate that an effective waste management system is compatible with the design of the development. An effective waste management system comprises of a system that is hygienic, clean, tidy, minimises waste being landfilled and maximises recycling and resource recovery;
- Ensure stakeholders are well informed of the design, roles and responsibilities required to implement the system;
- Provide supporting scaled drawings to confirm that the final design and construction is compliant with the report;
- Define the relevant stakeholders involved in ensuring the implementation of the waste management system; and
- Ensure tenants are not disadvantaged in access to recycling and other sustainable waste management options.

The following should be noted regarding the enclosed information:

- The waste generation volumes provided are estimates based on the best available waste generation rates. The actual waste volumes generated on-site may differ slightly from that estimated as it would depend on the occupancy rate of the development and tenant type (i.e. families or renters);
- The equipment specifications and any information provided regarding the recommended equipment are provided for reference purposes only and should not be relied upon for procurement. SALT recommends that the developer attains the latest specifications of the required equipment and service provisions from the respective contractor(s) prior to engaging them or purchasing the relevant equipment; and
- The report should be updated if the development plans are amended or if new legal requirements are introduced.

APPENDIX 1 DESIGN DRAWINGS



Rev	Description	By	Date
1	FOR SSSA ISSUE	KH	18/09/2025
2	DEPARTMENT ISSUES RESPONSE	KH	12/03/2026

Setia L1, 155 Franklin St, Melbourne, VIC 3000	Project Manager
Urbis L6, 123 Pitt St, Sydney, NSW 2000 Tel: (02) 9533 9900	Town Planner
Meinhardt 4/6 Clarence St, Sydney, NSW 2000 Tel: (02) 9699 3088	Structure & Building Services
Tract L6, 80 Meant St, North Sydney, NSW 2060 Tel: (02) 9654 3733	Landscape Architect
WT Partnerships L26, 45 Clarence Street, Sydney NSW 2000 (02) 9629 7422	Quantity Surveyor
Salt3 L6, 201 Kent St, Sydney NSW 2000 (02) 9088 7965	Traffic Engineer
Salt3 L6, 201 Kent St, Sydney NSW 2000 (02) 9088 7965	Waste Engineer

LEGEND

- SERVICES
- BICYCLE PARKING
- BUILDING MANAGEMENT
- COMMERCIAL
- RESIDENTIAL LOBBY
- RESIDENTIAL AMENITIES
- 1B RESIDENTIAL
- 2B RESIDENTIAL
- 3B RESIDENTIAL
- PENTHOUSE

Setia

COX

Cox Architecture
70 George Street
The Rocks NSW 2000
Australia
T + 61 2 9267 9599
coxarchitecture.com.au

Nominated Architects:
Joe Agius no. 6491
Ramin Jahromi no. 10000

Client: **Setia Sydney Pty Ltd**

Project No.: **223107.00**

Project: **ATCHISON STREET**
20-22 Atchison St, St Leonards, NSW 2065

Acknowledgement: In the language of the CAMMERAYGAL people.

Drawing Title: **LOWER GROUND**

Document Control Status:

Co-ordinated:	KH	Drawn:	KH
Project Architect:	RB	Scale:	1 : 100 @ A1
Project Director:	RJ	Date:	18/09/2025
Drawing Number:	A-DA-2110	Revision:	2

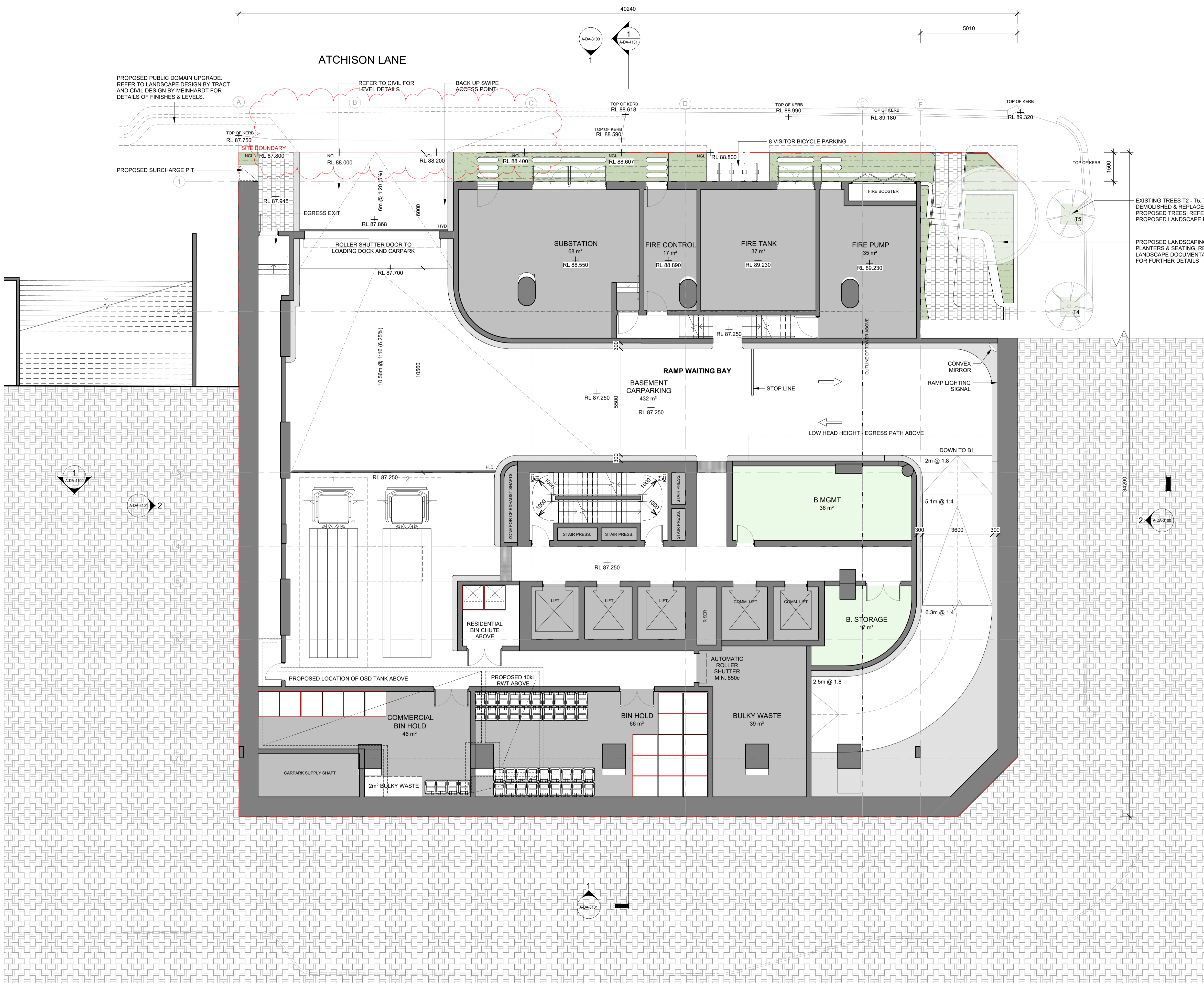

REFER TO LANDSCAPE REPORT BY TRACT AND CIVIL DRAWINGS BY MEINHARDT FOR FURTHER INFORMATION

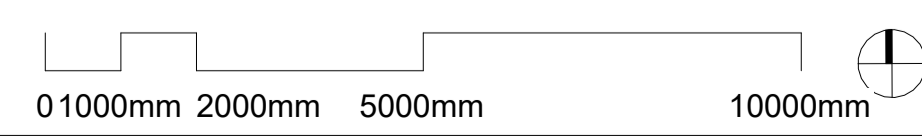

APPENDIX 2 SWEPT PATH ANALYSIS

INGRESS

EGRESS

10.5m WASTE TRUCK SWEPT PATH (TYP.)
(0.6m CLEARANCE SHOWN)

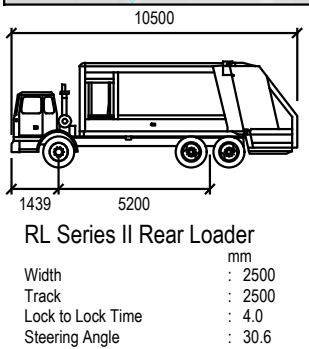
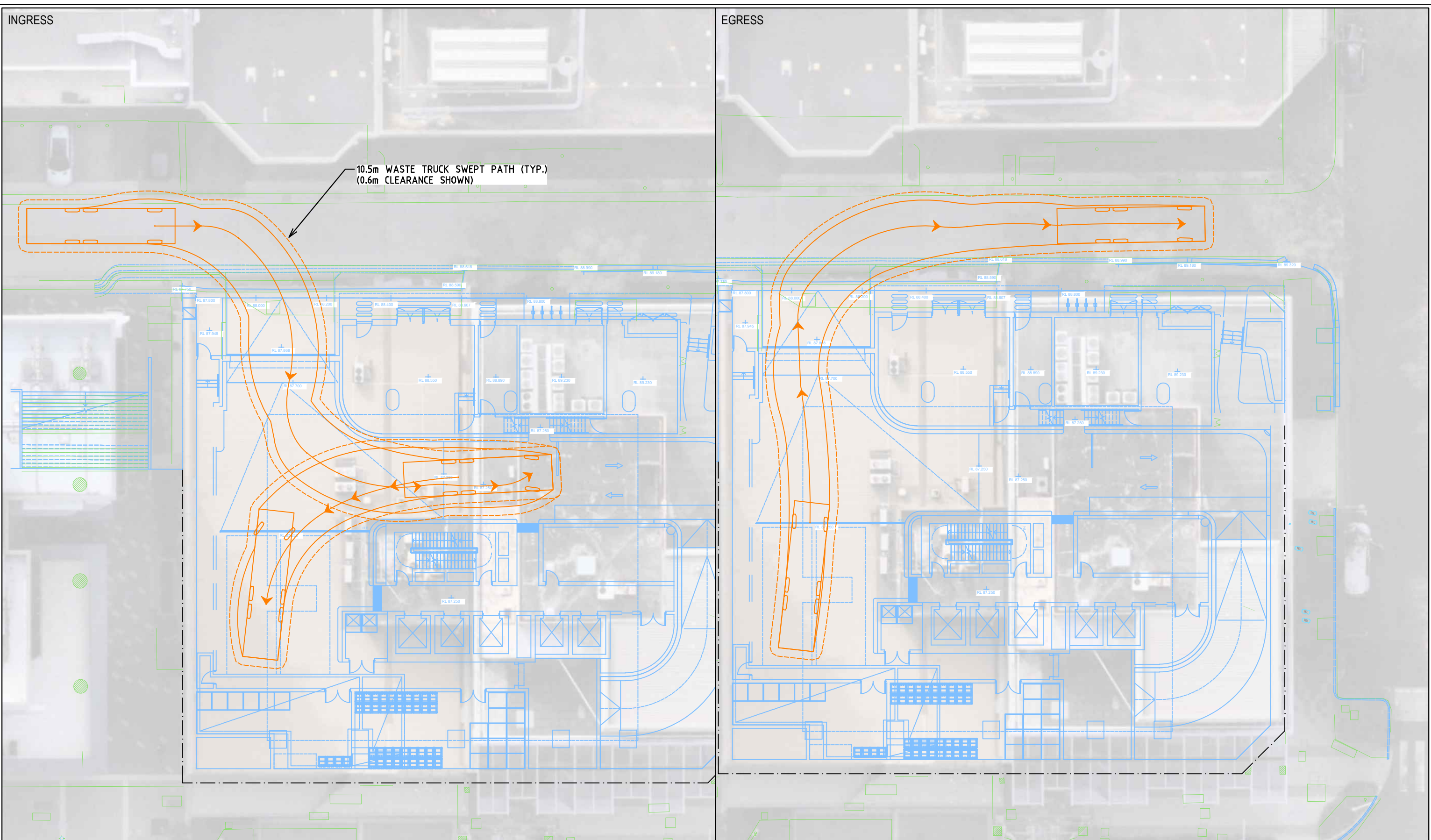

SETIA SYDNEY PTY LTD
 PROPOSED MIXED-USE DEVELOPMENT
 20-22 ATCHISON STREET
 ST LEONARDS
 SWEPT PATH DIAGRAM

SALT Service. Approachability. Loyalty. Transparency.

Level 6, 201 Kent St Sydney NSW 2000
 • MELBOURNE • ADELAIDE • PERTH • CANBERRA • HOBART • DARWIN
 ABN: 18 438 613 274 Email: salt@salt3.com.au Ph: 03 9020 4225

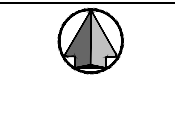
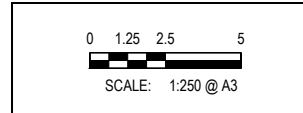

DRAWN / CHECKED LC / JG	DATE 10-03-2026	SIZE A3
DRAWING NUMBER SALT-25191-SK-008		REVISION 1

APPENDIX 3 COUNCIL WASTE COLLECTION VEHICLE SPECIFICATION

A4

SHEET

1 / 1

LAST REVISED

REVISED BY

19/03/2020

DWN

CHK

APP

MLP

SP

MLP

MLP

SP

19/03/2020

19/03/2020

19/03/2020

SP

DRAWING NO.:

RL20200464909

REV

A

DUE TO ON-GOING PRODUCT DEVELOPMENT, SUPERIOR PAK RESERVES THE RIGHT TO ALTER PRODUCT SPECIFICATIONS WITHOUT NOTICE

CHASSIS MODEL				ISUZU FVY240-300 AUTO (ACTUAL) 6X4 EURO 5 (RFS FUPS)			
BODY MODEL AND SIZE				REAR LOADER 20m3 COLLECTOR SERIES II CS RP HARD - ESTIMATED			
SUB FRAME SPEC				N/A			
AVERAGE PACK DENSITY (Kg/m3)				415			
				TOTAL (Kg)	FRONT AXLE (Kg)	REAR AXLE (Kg)	
CAB CHASSIS MASS				6790	3570	3220	
BODY INSTALLATION MASS				6170	-244	6414	
BODY SUBFRAME MASS				72	15	57	
DRIVER MASS				100	106	-6	
FUEL MASS				166	94	73	
ADDITIONAL OPTIONS MASS				250	-152	402	
TOTAL TARE MASS				13548	3389	10160	
NHVR GML, NT AND WA COMPLIANCE							
ESTIMATED PAYLOAD MASS				7700	1362	6338	
TOTAL VEHICLE MASS ESTIMATE LOADED				21248	4751	16497	
LEGAL AXLE LOADS				23000	6500	16500	
NHVR CML & HML, NT WITH RFS AND WA AMMS 1 & 2 COMPLIANCE							
ESTIMATED PAYLOAD MASS				8300	1362	6832	
TOTAL VEHICLE MASS ESTIMATE LOADED				21848	4857	16991	
LEGAL AXLE LOADS				23500	6500	17000	
MAXIMUM POTENTIAL PAYLOAD MASS				9952			
OPTIMISED FOR BEST PAYLOAD WITH MOST SUITABLE STD WB.				(TABLE V11.5)		27/08/2019	
ADDITIONAL OPTIONS INCL.: RL SII TUCKAWAY LIFTER, 12mm FLAT BAR.. REAR LOADER VOLUME INCL.: BODY ONLY							
REAR LOADER OPTIONS							
DESCRIPTION				TOTAL (Kg)	FRONT AXLE (Kg)	REAR AXLE (Kg)	
TOOLBOX DOUBLE				40	20	20	
RL SII BIN STOP FRAME (BASIC)				39	-23	62	
RL SII BIN STOP FRAME (PNEUMATIC)				45	-26	71	
RL SII CANOPY				116	-60	176	
RL SII/SIII BIN STOP FRAME (FOR HEAVY DOOR ONLY)				18	-11	29	

- NOTES**
- 1 WEIGHTS AND MEASUREMENTS ARE THEORETICAL / ESTIMATED ONLY AND ARE SUBJECT TO MANUFACTURING TOLERANCES.
 - 2 THE LOAD CENTRE OF MASS IS AN ESTIMATE ONLY. THIS WILL VARY THROUGHOUT THE LOADING CYCLE AND WILL BE ENTIRELY DEPENDENT ON THE MAKE UP OF THE LOAD STREAM.
 - 3 CALCULATIONS INCLUDE 200 LITRES OF FUEL AND A 100 DRIVER.
 - 4 THE FRONT LEGAL AXLE LOAD IS BASED ON THE VEHICLE BEING FITTED WITH AN ECE R93 FUPS BAR AND A CAB COMPLYING WITH ECE R29. VEHICLE OWNER TO CONFIRM AXLE WEIGHTS WITH STATE AUTHORITIES AND VEHICLE SPECIFICATION WITH THE MANUFACTURER.
 - 5** MAXIMUM POTENTIAL PAYLOAD CAN OCCUR ONLY WHEN THE AXLE LOADS ARE FULLY EXPLOITED. THEREFORE ESTIMATED PAYLOAD DUE TO DISTRIBUTED MASS IS A MORE CONSERVATIVE ESTIMATE.
 - 6 THE VOLUME BREAK DOWN IS AS FOLLOWS:

BODY (EX BLADE)	=	17.40 m3
HOPPER/REAR DOOR	=	02.50 m3
TOTAL	=	19.90 m3
 - 7 THE ADDITION OF OPTIONS OVER AND ABOVE THE STANDARD SPECIFICATIONS MAY IMPACT ON THE MAXIMUM PAYLOAD THAT THE VEHICLE CAN LEGALLY CARRY.
 - 8 NHVR COVERS EVERYWHERE EXCEPT FOR NT AND WA WHICH HAVE SEPARATE COMPLIANCE LAWS
- PTO NOTES**
REFER TO THE LATEST "SPK-ENG-56-020 RL PTO SPEC" ON THE PORTAL
- ADDITIONAL NOTES**
BODY POSITION = 1600 (NO STD AVAILABLE) / OVERHANG = 63.6% (AU) / WHEELBASE = 5200 (AU) ACTUAL
INCREASED LEGAL AXLE LOADS MAY BE AVAILABLE. CONFIRM WITH VEHICLE MANUFACTURER AND STATE AUTHORITIES

REFERENCE ONLY

(UNSUITABLE CONFIGURATION - CUSTOMER TO ENSURE REAR OVERHANG EXEMPTION PERMIT CAN BE OBTAINED FOR THIS CONFIGURATION)

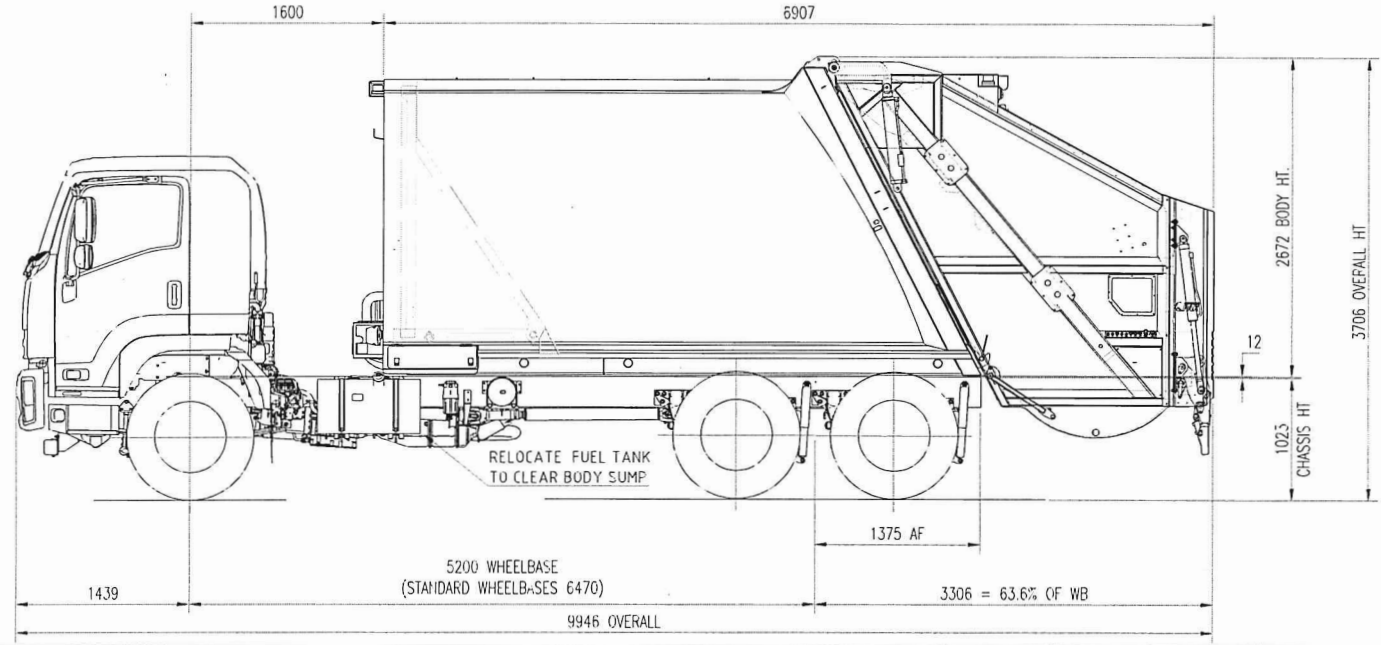

THIS DRAWING IS THE PROPERTY OF SUPERIOR PAK PTY LTD. AND MUST NOT BE RETAINED, COPIED OR USED WITHOUT SUPERIOR PAK'S WRITTEN AUTHORITY

SPECIFICATIONS

TITLE:

RL SERIES II REAR LOADER
20m³ RAISED PROFILE MODEL (RP) HARD WASTE
ISUZU FVY240-300 6X4 (EURO 5) RFS FUPS



Service. Approachability. Loyalty. Transparency.

MELBOURNE

Level 6, 350 Collins St Melbourne VIC 3000

T: +61 3 9020 4225

SYDNEY

Level 6, 201 Kent St Sydney NSW 2000

T: +61 2 9068 7995

HOBART

Level 5, 24 Davey St Hobart TAS 7000

T: +61 400 535 634

CANBERRA

Level 2, 28 Ainslie Pl Canberra ACT 2601

T: +61 2 9068 7995

ADELAIDE

Level 21, 25 Grenfell St Adelaide SA 5000

T: +61 8 8484 2331

DARWIN

Level 1 Suite 2A, 82 Smith St Darwin City NT 0800

T: +61 8 8484 2331

PERTH

Level 25, 108 St Georges Tce, Perth WA 6000

T: +61 8 6557 8888

Sustainable Transport Surveys Pty Ltd

ABN: 18 439 813 274

www.salt3.com.au